

NAVAL POSTGRADUATE SCHOOL Monterey, California



THESIS

**OPTIMAL ALLOCATION OF ASSAULT SUPPORT
AIRCRAFT IN THE SUSTAINMENT OF MARINE CORPS
EXPEDITIONARY MANEUVER WARFARE**

by

Michael J. Powell

September 2002

Thesis Advisor:

Javier Salmeron

Second Reader:

David A. Schradly

Approved for public release; distribution is unlimited.

*Amateurs discuss strategy,
Professionals study logistics*

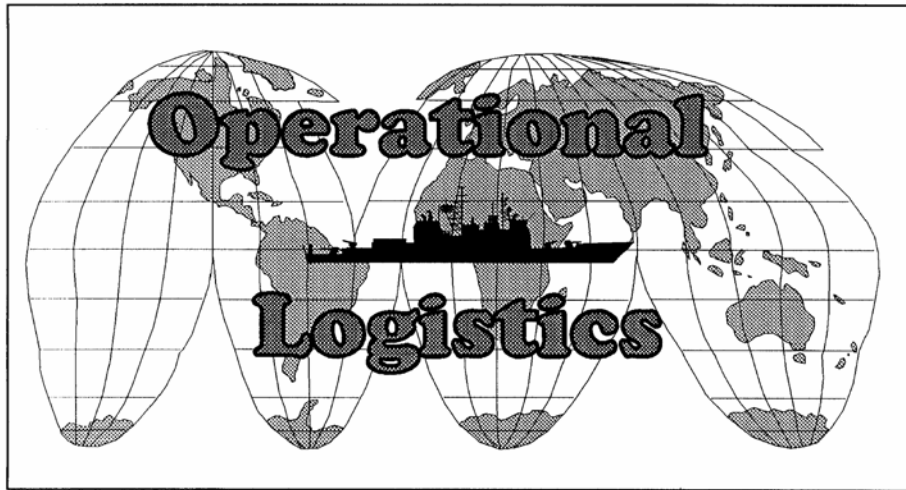

REPORT DOCUMENTATION PAGE			Form Approved OMB No. 0704-0188	
Public reporting burden for this collection of information is estimated to average 1 hour per response, including the time for reviewing instruction, searching existing data sources, gathering and maintaining the data needed, and completing and reviewing the collection of information. Send comments regarding this burden estimate or any other aspect of this collection of information, including suggestions for reducing this burden, to Washington headquarters Services, Directorate for Information Operations and Reports, 1215 Jefferson Davis Highway, Suite 1204, Arlington, VA 22202-4302, and to the Office of Management and Budget, Paperwork Reduction Project (0704-0188) Washington DC 20503.				
1. AGENCY USE ONLY (Leave blank)	2. REPORT DATE September 2002	3. REPORT TYPE AND DATES COVERED Master's Thesis		
4. TITLE AND SUBTITLE: Optimal Allocation of Assault Support Aircraft in the sustainment of Marine Corps Expeditionary Maneuver Warfare			5. FUNDING NUMBERS	
6. AUTHOR(S) Michael J. Powell				
7. PERFORMING ORGANIZATION NAME(S) AND ADDRESS(ES) Naval Postgraduate School Monterey, CA 93943-5000			8. PERFORMING ORGANIZATION REPORT NUMBER	
9. SPONSORING /MONITORING AGENCY NAME(S) AND ADDRESS(ES) N/A			10. SPONSORING/MONITORING AGENCY REPORT NUMBER	
11. SUPPLEMENTARY NOTES The views expressed in this thesis are those of the author and do not reflect the official policy or position of the Department of Defense or the U.S. Government.				
12a. DISTRIBUTION / AVAILABILITY STATEMENT Approved for public release; distribution is unlimited			12b. DISTRIBUTION CODE	
<p align="center">ABSTRACT (maximum 200 words)</p> <p>As the United States enters a new millennium, the armed forces, and in particular the Marine Corps, face new challenges in the manner that they deploy and operate. Reductions in both personnel and naval shipping, coupled with an ever-changing world political environment, have led to a dramatic shift in the way that the United States must project its power.</p> <p>As recent combat operations in Afghanistan have demonstrated, there is a valid requirement for forces to possess the ability to operate from the sea directly to an objective area with minimal or no amphibious landing support. This thesis provides an analysis of the most advantageous assault support aircraft allocation aboard a Marine Expeditionary Unit (MEU) in operations such as this. With the MEU tasked as one of the prominent fixtures in the timely projection of power ashore for the United States, the capabilities (or lack thereof) of assault support aircraft become increasingly important as ship-to-objective distances increase.</p> <p>Our method of finding an optimal composition of aircraft consists of constructing an Assault Support Optimization Model (ASOM). ASOM assists us in prescribing an ideal configuration of assault support aircraft while emulating the dynamic amphibious environment. ASOM analyzes the assignment of several aircraft combinations (4 CH-53E/12 MV-22, 6 CH-53E/10 MV-22, 8 CH-53E/8 MV-22 and 10 CH-53E/6 MV-22) establishing which delivers the greatest ship to objective support to the MEU's Ground Combat Element. The results on various runs of ASOM (at distances of 50nm, 75nm, 100nm and 125nm) identify that the optimal aircraft composition varies with ship-to-objective distances. Overall differences are not dramatic and we do not have further evidence that any aircraft combination clearly outperforms the others. According to the heuristic results obtained in this thesis, we would cautiously recommend a mix of 6 CH-53E and 10 MV-22 aircraft which, on average, seems to produce better results, and is always the best or second choice regardless of the ship-to-objective distance.</p>				
13. SUBJECT TERMS Operational Maneuver From The Sea (OMFTS), Ship-to-Objective Maneuver (STOM), sustainment, Expeditionary Maneuver Warfare, MV-22, CH-53E, Marine Expeditionary Unit (MEU), Optimization, Network Models			15. NUMBER OF PAGES 78	16. PRICE CODE
17. SECURITY CLASSIFICATION OF REPORT Unclassified	18. SECURITY CLASSIFICATION OF THIS PAGE Unclassified	19. SECURITY CLASSIFICATION OF ABSTRACT Unclassified	20. LIMITATION OF ABSTRACT UL	

THIS PAGE INTENTIONALLY LEFT BLANK

Approved for public release; distribution is unlimited.

**OPTIMAL ALLOCATION OF ASSAULT SUPPORT AIRCRAFT IN THE
SUSTAINMENT OF MARINE CORPS EXPEDITIONARY MANEUVER
WARFARE**

Michael J. Powell
Major-United States Marine Corps
B.S., Montana State University, 1991

Submitted in partial fulfillment of the
requirements for the degree of

MASTER OF SCIENCE IN OPERATIONS RESEARCH

from the

**NAVAL POSTGRADUATE SCHOOL
September, 2002**

Author: Michael J. Powell

Approved by: Javier Salmeron
Thesis Advisor

David A. Schradly
Second Reader

James N. Eagle
Chairman, Department of Operations Research

THIS PAGE INTENTIONALLY LEFT BLANK

ABSTRACT

As the United States enters a new millennium, the armed forces, and in particular the Marine Corps, face new challenges in the manner that they deploy and operate. Reductions in both personnel and naval shipping, coupled with an ever-changing world political environment, have led to a dramatic shift in the way that the United States must project its power.

As recent combat operations in Afghanistan have demonstrated, there is a valid requirement for forces to possess the ability to operate from the sea directly to an objective area with minimal or no amphibious landing support. This thesis provides an analysis of the most advantageous assault support aircraft allocation aboard a Marine Expeditionary Unit (MEU) in operations such as this. With the MEU tasked as one of the prominent fixtures in the timely projection of power ashore for the United States, the capabilities (or lack thereof) of assault support aircraft become increasingly important as ship-to-objective distances increase.

Our method of finding an optimal composition of aircraft consists of constructing an Assault Support Optimization Model (ASOM). ASOM assists us in prescribing an ideal configuration of assault support aircraft while emulating the dynamic amphibious environment. ASOM analyzes the assignment of several aircraft combinations (4 CH-53E/12 MV-22, 6 CH-53E/10 MV-22, 8 CH-53E/8 MV-22 and 10 CH-53E/6 MV-22) establishing which delivers the greatest ship to objective support to the MEU's Ground Combat Element. The results on various runs of ASOM (at distances of 50nm, 75nm, 100nm and 125nm) identify that the optimal aircraft composition varies with ship-to-objective distances. Overall differences are not dramatic and we do not have further evidence that any aircraft combination clearly outperforms the others. According to the heuristic results obtained in this thesis, we would cautiously recommend a mix of 6 CH-53E and 10 MV-22 aircraft which, on average, seems to produce better results, and is always the best or second choice regardless of the ship-to-objective distance.

THIS PAGE INTENTIONALLY LEFT BLANK

DISCLAIMER

The reader is cautioned that computer programs developed in this research may not have been exercised for all cases of interest. While every effort has been made, within the time available, to ensure that the programs are free of computational and logic errors, they cannot be considered validated. Any application of these programs without additional verification is at the risk of the planner.

THIS PAGE INTENTIONALLY LEFT BLANK

TABLE OF CONTENTS

I.	INTRODUCTION.....	1
A.	MANUEVER WARFARE.....	1
B.	OPERATIONAL MANEUVER FROM THE SEA.....	1
C.	SHIP-TO-OBJECTIVE MANUEVER.....	2
D.	MARINE AIR-GROUND TASK FORCE.....	4
E.	THESIS OBJECTIVES.....	5
F.	RECENT STUDIES.....	6
II.	MODEL DEVELOPMENT.....	9
A.	METHODOLOGY FOR FORMULATION.....	9
B.	AIRCRAFT FLOW NETWORK.....	11
C.	ASSUMPTIONS.....	16
D.	ASSAULT SUPPORT OPTIMIZATION MODEL.....	17
E.	METHODOLOGY FOR SOLVING THE MODEL.....	23
III.	DETERMINATION OF REQUIREMENTS.....	29
A.	FORCE STRUCTURE TO BE SUPPORTED.....	29
B.	CLASSES OF SUPPLY.....	31
C.	SUPPORTING ASSETS.....	32
D.	REQUIREMENTS.....	38
IV.	RESULTS.....	43
A.	ANALYSIS OF SHIP-TO-OBJECTIVE DISTANCES.....	43
V.	CONCLUSIONS.....	49
A.	OVERVIEW.....	49
B.	RECOMMENDATIONS FOR FURTHER STUDY.....	49
	LIST OF REFERENCES.....	51
	INITIAL DISTRIBUTION LIST.....	55

THIS PAGE INTENTIONALLY LEFT BLANK

LIST OF SYMBOLS, ACRONYMS AND/OR ABBREVIATIONS

AAAV	Advanced Assault Amphibious Vehicle
ACE	Aviation Combat Element
AH-1Z	Attack Helicopter
ARG	Amphibious Readiness Group
ASOM	Assault Support Optimization Model
B&B	Branch and Bound
BLT	Battalion Landing Team
BSA	Beach Support Area
BSSG	Brigade Service Support Group
C ²	Command and Control
CAS	Close Air Support
CATF	Commander, Amphibious Task Force
CE	Command Element
CH-53E	Heavy Lift Helicopter
CH-60S	Combat Support Helicopter
CLF	Commander, Landing Force
CSS	Combat Service Support
CSSD	Combat Service Support Detachment
CSSE	Combat Service Support Element
EMW	Expeditionary Maneuver Warfare
F&R	Fix and Relax
FSSG	Force Service Support Group
GAMS	General Algebraic Modeling System
GCE	Ground Combat Element
HMMWV	High Mobility, Multi-Wheeled Vehicle
H&S	Headquarters and Service Company
JFC	Joint Force Commander
JSF-STOVL	Joint Strike Fighter, Short Take-Off, Vertical Landing
LAV	Light Armored Vehicle

lbs	Pounds
LCAC	Landing Craft, Air Cushioned
LHD	Amphibious Assault Ship (Multipurpose)
LPD	Amphibious Transport Dock
LPF	Logistics Planning Factor
LSD	Dock Landing Ship
LW-155	Light Weight 155mm Howitzer
LZ	Landing Zone
M-198	155mm Howitzer
M1-A1	Main Battle Tank
MAG	Marine Air Group
MAGTF	Marine Air-Ground Task Force
MV-22	Medium Lift Tiltrotor Aircraft
MAW	Marine Aircraft Wing
MEDEVAC	Medical Evacuation
MEB	Marine Expeditionary Brigade
MEF	Marine Expeditionary Force
MEU	Marine Expeditionary Unit
MEU(SOC)	Marine Expeditionary Unit, Special Operations Capable
MIP	Mixed Integer Program
MRE	Meal, Ready-to-Eat
MSSG	Marine Expeditionary Unit Service Support Group
MTVR	Medium Tactical Vehicle Replacement
NATOPS	Naval Air Training and Operating Procedures Standardization
nm	Nautical Mile
Nr	Prop Rotor Speed
OMFTS	Operational Maneuver from the Sea
RAM	Random Access Memory
SBL	Sea-Based Logistics
STOM	Ship-to-Objective Maneuver
UH-1Y	Utility Helicopter
VTOL	Vertical Take-Off and Landing

LIST OF FIGURES

Figure 1	Current Amphibious Doctrine.....	3
Figure 2	Ship to Objective Manuever.....	3
Figure 3.	Static Network for Aircraft Allocation.....	12
Figure 4.	LHD Specific Network Nodes.	13
Figure 5.	MEU Command Relationship.	29
Figure 6.	Wasp Class LHD-6, USS Bonhomme Richard.....	33
Figure 7.	MV-22 on the flight deck of an LHD.....	34
Figure 8.	A CH-53E aerial refueling above an LHD.....	35
Figure 9.	Total Supplies Delivered at 50nm.....	43
Figure 10.	Total Supplies Delivered at 75nm.....	44
Figure 11.	Total Supplies Delivered at 100nm.....	45
Figure 12.	Total Supplies Delivered at 125nm.....	46
Figure 13.	Total Supplies Delivered utilizing 4 CH-53E and 12 MV-22 aircraft.	47
Figure 14.	Total Supplies Delivered utilizing 6 CH-53E and 10 MV-22 aircraft.	47
Figure 15.	Total Supplies Delivered utilizing 8 CH-53E and 8 MV-22 aircraft.	48
Figure 16.	Total Supplies Delivered utilizing 10 CH-53E and 6 MV-22 aircraft.	48

THIS PAGE INTENTIONALLY LEFT BLANK

LIST OF TABLES

Table 1.	MEU Feasible Aircraft Allocations.....	10
Table 2.	MEU Force Structure	10
Table 3.	Close Air Support & AH-1/UH-1 Deck Spot Utilization	15
Table 4.	ASOM Computational Run Time	27
Table 5.	MEU Ship Assignments.....	29
Table 6.	Ships of the Amphibious Readiness Group utilized in ASOM.....	33
Table 7.	Assault Support Aircraft Airspeeds and Total Lift Capacity	36
Table 8.	Assault Support Aircraft Lift Capacity (Range Dependent).....	36
Table 9.	Aircraft Capacity of Nodes within ASOM.....	37
Table 10.	MEU GCE Daily Lift Requirements.....	39
Table 11.	Demand for Commodities at Landing Zones	40
Table 12.	Commodities Available on ships within the ARG.....	40

THIS PAGE INTENTIONALLY LEFT BLANK

ACKNOWLEDGMENTS

It is with extreme gratitude that I thank both Professor Javier Salmeron and Professor David Schradly for their professional guidance, assistance and encouragement over the past year. I would also like to thank my two boys for their patience and understanding. Thank you. I love you both.

THIS PAGE INTENTIONALLY LEFT BLANK

EXECUTIVE SUMMARY

As the United States enters a new millennium, the armed forces, and in particular the Marine Corps, face new challenges in the manner that they deploy and operate. Reductions in both personnel and naval shipping, coupled with an ever-changing world political environment, have led to a dramatic shift in the way that the United States must project its power.

As recent combat operations in Afghanistan have demonstrated, there is a valid requirement for forces to possess the ability to operate from the sea directly to an objective area with minimal or no amphibious landing support. This thesis provides an analysis of the most advantageous assault support aircraft allocation aboard a Marine Expeditionary Unit (MEU) in this type of operations. With the MEU tasked as one of the prominent fixtures in the timely projection of power ashore for the United States, the capabilities (or lack thereof) of assault support aircraft become increasingly important as ship-to-objective distances increase.

The assault support aircraft assigned to a Marine Expeditionary Unit (MEU) of the future utilize a one-for-one exchange of CH-46Es with the new MV-22 Tiltrotor aircraft. This thesis utilizes this assumed allocation as a baseline, and then analyzes the assignment of several additional aircraft combinations, establishing which delivers the greatest ship to objective support to the MEU's Ground Combat Element (GCE).

The model constructed for this analysis, Assault Support Optimization Model (ASOM), is formulated to ensure that the highly dynamic environment of ship-board operations is emulated as close to reality as possible. While ASOM does attempt to mimic these type of operations, we are not able to distinguish factors such as the varying fuel burn rates, cargo dependent sortie times, and the loading/unloading times for internal versus external lift cargoes.

With the results at hand at this point, we anticipate that further improvement of the methodology used in this research (especially reducing the computational time) would provide added benefits to the MAGTF planner. Some of these benefits include

providing the planner with an optimal sortie schedule, thereby ensuring that support provided to units ashore is maximized. Secondly, the model can be utilized to provide insight to the MEU commander in advance of a deployment. This would then ensure that he is provided with the essential information on the proper aircraft allocation for the specific mission of which he expects to encounter, or at the very least, provide several options on which he may base his decisions.

The results on various runs of ASOM (at distances of 50nm, 75nm, 100nm and 125nm) identify that the optimal aircraft composition varies with ship-to-objective distances. Overall differences are not dramatic and we do not have further evidence that any aircraft combination clearly outperforms the others. According to the heuristic results obtained in this thesis, we would cautiously recommend a mix of 6 CH-53E and 10 MV-22 aircraft which, on average, seems to produce better results, and is always the best or second choice regardless of the ship-to-objective distance.

Although these results are insightful, a more thorough study should be performed once the MV-22 has been fully integrated into the Marine Corps. This will allow the incorporation of actual data extracted from fleet squadrons, providing a more realistic approach to the problem at hand.

I. INTRODUCTION

“Throughout the struggle, it was in his logistic inability to maintain his armies in the field that the enemy’s fatal weakness lay. Courage his forces had in full measure, but courage was not enough. Reinforcements failed to arrive, weapons, ammunition and food alike ran short, and the dearth of fuel caused their powers of tactical mobility to dwindle to the vanishing point. In the last stages of the campaign they could do little more than wait for the Allied advance to sweep over them.”

—Dwight Eisenhower
[U.S. Army (1994)]

A. MANUEVER WARFARE

The United States Marine Corps has established that Expeditionary Maneuver Warfare (EMW) will be the capstone concept for the 21st Century. The Marine Corps will rely heavily upon the capabilities and philosophy of EMW to promote peace and stability, and mitigate or resolve crises as part of a joint force. EMW focuses Marine Corps competencies, evolving capabilities and innovative concepts to ensure that we provide the Joint Force Commander (JFC) with the forces optimized for forward presence, engagement, crisis response, antiterrorism, and warfighting. [United States Marine Corps (2001)].

The shift in reliance from the quantitative characteristics of warfare – mass and volume – to a realization that qualitative factors (speed, stealth, precision, and sustainability) have become increasingly important facets of modern warfare. [United States Marine Corps (2001)]. The backbone of EMW is Operational Maneuver From the Sea (OMFTS) and one application of this concept is Ship-To-Objective Maneuver (STOM).

B. OPERATIONAL MANEUVER FROM THE SEA

This concept best describes rapid maneuver by landing forces from their ships directly to objectives ashore, uninterrupted by topography or hydrography. [United States Marine Corps (1997)]. The maneuver space of the sea and littorals provides the tactical option to attack the enemy at the commander’s discretion, allowing the opportunity to hit the enemy flanks, rear or other fragile points within his positions. Traditional

amphibious doctrine emphasizes landing the Ground Combat Element (GCE) ashore, subsequent build up of a large beach support area (BSA), then advancing to an objective. With this built up comes an operational pause, and subsequent loss of both momentum and the element of surprise.

C. SHIP-TO-OBJECTIVE MANUEVER

This concept is the tactical application of maneuver warfare to the littorals. Maneuver of the ground forces will occur from ship directly to the objective area, using the sea as a maneuver space. Essentially, by bypassing the requirement to establish a large beachhead, the Marine Expeditionary Unit (MEU) becomes more flexible in its tactical options and maneuverability. No longer is the MEU tied to the life-line that the BSA provides as support. This support will arrive directly from the ships via aircraft, reducing both security and support requirements, thus increasing flexibility in the maneuver of the GCE. With the introduction of new technology in both command and control (C²) and asset visibility technologies, the Marine Corps will be able to have forces access, manipulate, and use information in near real time, developing a common tactical and operational understanding of the battlespace, and thus promoting a more decentralized execution. [U.S. Marine Corps, (1997), (2001)]. By doing so, the Marine Corps gains speed, surprise, and tactical flexibility to accomplish its mission.

Figure 1 illustrates the traditional approach to amphibious assaults. A small portion of the Battalion Landing Team (BLT) conducts heliborne operations, with the remainder of the GCE coming ashore by both amphibious assault vehicles and Landing Craft Air Cushioned (LCAC). The second phase then starts with the build up of the beach with supplies, logistic support vehicles, and additional support personnel. These supplies and personnel then require security forces, and supplies to sustain themselves. This creates an immobile and potentially vulnerable fixture within the area of operations. The third phase follows with the advance of the GCE to the objective(s). The concept of STOM considers removing or substantially reducing the second phase to increase tactical maneuverability.

Current Amphibious Assault Doctrine

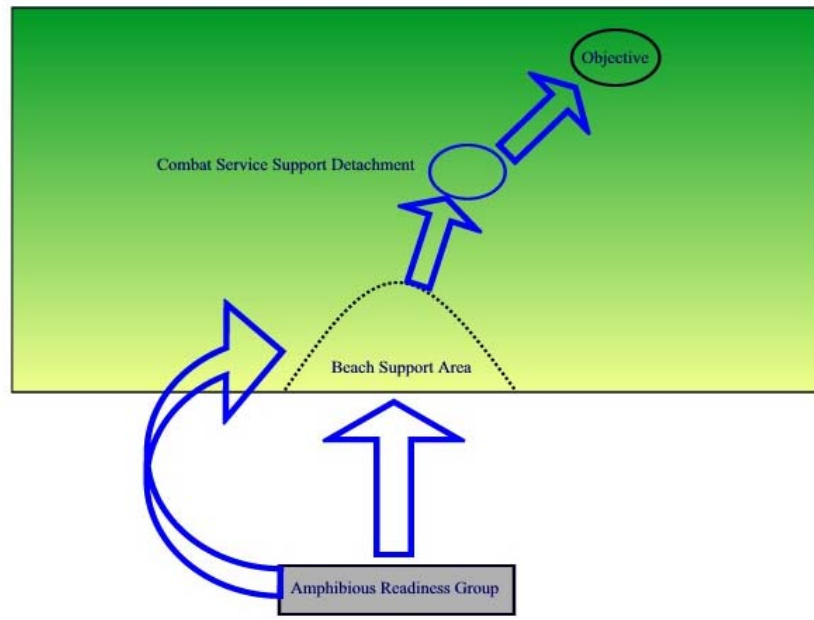

Figure 1. Current Amphibious Doctrine. Assault force secures a beach support area, and conducts follow-on operations to the objective. Support is routed from the ARG through the BSA to Combat Service Support Detachments (CSSD), ultimately reaching combat units.

Ship-to-Objective Maneuver

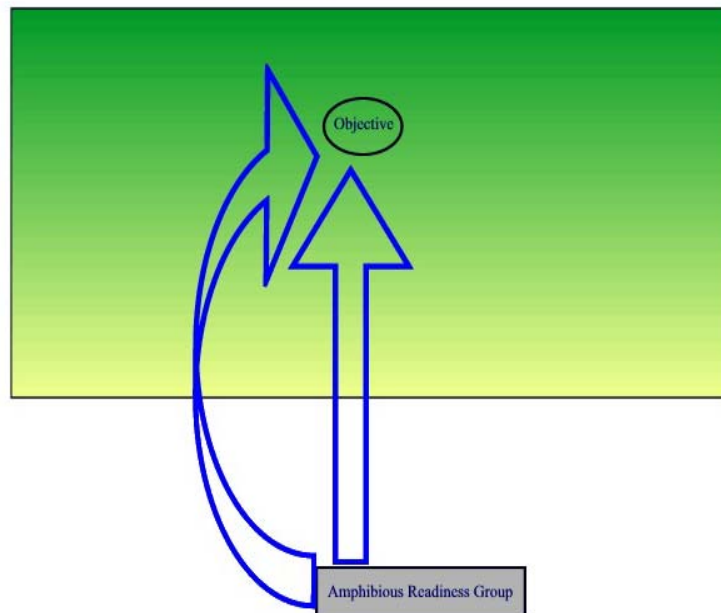

Figure 2. Ship-To-Objective Maneuver. Assault on the objective is accomplished by utilizing either assault support aircraft or Advanced Amphibious Assault Vehicles (AAAV) or LCACs or a combination of all three, with no operational pause at the beach.

Figure 2 depicts the basic STOM concept. A majority of the Marines within the GCE would come ashore via CH-53E heavy lift helicopter and MV-22 medium lift tiltrotor aircraft. The MEU may still plan on an amphibious landing, but only for the deployment of major weapons systems such as High Mobility Multi-Wheeled Vehicle (HMMWV), Light Armored Vehicles (LAV), and possibly M1-A1 main battle tanks. Follow-on sustainment of these forces would then arrive directly from the Amphibious Readiness Group (ARG) using the MEU's assault support aircraft.

D. MARINE AIR-GROUND TASK FORCE

The Marine Air-Ground Task Force (MAGTF) is the Marine Corps' principle organization for the conduct of all missions across the range of military operations. MAGTFs are balanced, combined-arms forces with organic ground, aviation, and sustainment elements. [United States Marine Corps (1998)]. The MAGTF is composed of several elements that may be scaled according to the mission and requirements. These four elements are the Command Element (CE), the Aviation Combat Element (ACE), the Ground Combat Element (GCE) and the Combat Service Support Element (CSSE). These four elements, when combined, form the blueprint for which all MAGTFs are fashioned. The Marine Corps can tailor a MAGTF to support most missions; however, there are three standard MAGTFs that are easily identified.

1. Marine Expeditionary Force (MEF)

The MEF is the principle Marine Corps warfighting organization. It is capable of missions across the range of military operations, through amphibious assault and sustained operations ashore in any environment. [U.S. Marine Corps (1998)]. The typical composition of a MEF includes a CE, a Marine division, a Marine Air Wing (MAW), and a Force Service Support Group (FSSG).

2. Marine Expeditionary Brigade (MEB)

The MEB is optimally scaled and task-organized to respond to a full range of crises. The MEB can be strategically deployed via a variety of modes (amphibious shipping, strategic air and sea lift) and poised for sustainable power projection. [U.S. Marine Corps (2001)]. The typical composition of a MEB includes a CE, a Marine Regiment, a Marine Air Group (MAG), and a Brigade Service Support Group (BSSG).

3. Marine Expeditionary Unit (Special Operations Capable) (MEU(SOC))

The MEU(SOC) is forward deployed from the sea, unconstrained by regional infrastructure requirements or restrictions imposed by other nations. Because of its forward presence, situational awareness, rapid response planning capability, and organic sustainment, the MEU(SOC) will continue to be the JFC's employable combined arms force of choice. [U.S. Marine Corps (2001)]. The MEU(SOC) deploys aboard an ARG, consisting of three to four vessels. The mainstay ship being the Amphibious Assault ship (LHD), complemented by an Amphibious Transport Dock (LPD) and the Dock Landing Ship (LSD). The MEU(SOC) (hereafter referred simply as MEU), consists of a CE, BLT, a composite squadron, and a task-organized MEU Service Support Group (MSSG). The MEU is self-sustainable for a period of approximately 15 days.

E. THESIS OBJECTIVES

The objective of this thesis is to provide Marine commanders and planners with the analytical information on the most advantageous assignment of assault support aircraft aboard MEUs of the future.

Ship-to-objective maneuver will require more than the traditional hammer and nail approach to flight scheduling, aircraft assignments and logistical resupply. If we factor in the additional requirements of LCAC operations, armed escort flights, command and control and close air support, we realize the problem's complexities. This thesis proposes the use optimization techniques to address this problem.

The thesis will utilize the daily lift requirements generated by the MEU GCE in two locations ashore. These lift requirements will consist of subsistence (supply class I), fuel (class III), ammunition (class V), personnel and the Light Weight 155mm Howitzer (LW-155). The analysis will concentrate on exploiting various combinations of the MV-22 and CH-53E aircraft assignments that the ARG has the capability to support. The overall objective is to minimize the unmet demand at both locations by the end of a 10 hour time period. The fundamental constraints that this model attempts to capture within shipboard environment are:

- Limited deck spots (both in number and size), aircraft slash line and hangar deck space limitations.
- Joint Strike Fighter Short Take Off and Vertical Landing Aircraft (JSF-STOVL) concurrent operations.
- AH-1Z attack helicopter and UH-1Y utility helicopter concurrent operations.
- Assault support aircraft fuel and lift capacity constraints.
- Stand-off distances of the ARG.

When we combine these constraints with the limited flight window available aboard the ARG, the result is a realistic, dynamic model that lends itself well to providing a tool for the analysis at hand.

F. RECENT STUDIES

Recent studies have attempted to evaluate the ability of the ARG to support OMFTS/STOM operations. Although this thesis is similar in some aspects to previous research at the Naval Postgraduate School, it does not seek to qualify the feasibility of OMFTS. Rather, our goal is to determine whether there is an optimal assignment of assault support aircraft that can deliver the greatest amount of supplies, while still maintaining favorable stand-off distances of the ARG.

U.S. Navy Lt. Mark Beddoes [Beddoes (1997)] utilized a deterministic approach to aid in calculating the maximum distance from the beach that sea-based CSS assets would be able to maintain and still support operations of the type that OMFTS envisions. Lt. Beddoes (as well as other authors mentioned below), assumed a one-for-one replacement of the CH-46E with the MV-22, while maintaining the current assignment of four CH-53E aircraft. This work concluded that the ships of the ARG could not remain more than 100nm from shore, and still satisfy the logistical requirements.

U.S. Marine Corps Major Robert Hagan's thesis [Hagan (1998)] models the sea-based sustainment of a MEU. By creating and analyzing five typical MEU scenarios, and determining sustainment requirements and available transportation capacities for each, Major Hagan was able to deduce that a competition between resupply sorties and tactical mobility sorties will exist in the OMFTS environment. His analysis revealed that, in

many cases, sustainment sorties alone required more sorties than were actually available. He also identified that there exists a requirement to more efficiently manage the aerial transportation of liquid products (water and fuel) than is currently utilized. By incorporating improvements in this area, a substantial decrease in the number of sustainment sorties would be possible. As a result of his thesis, our research will only utilize the “enabling force” scenario, which Major Hagan recognized as the single scenario that produced the maximum requirement for resupply sorties.

The work by Navy Lt. Harold Viado [Viado (1999)] is the first thesis that proposes the use of a network optimization model to plan an optimal deliver schedule. His Sea-Based Logistics Optimization Model is a mixed-integer program that determines the minimum initial level of fuel required at the LZs and for the Marines of the MEU’s BLT. Viado’s model uses the idea of network expanded by time, as we do in this thesis. Our thesis also models different cargoes as a multi-commodity problem, and explicitly represents the individual capacity of each deck spot over time, depending on whether it is in use or not by existing lift requirements.

Marine Captain Norman Reitter’s thesis [Reitter (1999)] focused on sustainment and distribution in a sea-based environment. His Sea-Based Logistics Decision Support System is developed to assist sustainment planners in this environment to predict inventory levels of forces ashore and assist in managing transportation assets. A utilization schedule is constructed to determine if a feasible distribution plan exists.

The thesis authored by Marine Captain Christopher Frey [Frey (2000)] models the sea-based sustainment of MEB forces deployed from amphibious shipping. With his optimization model, Frey analyzes twenty-seven cases (per day, over 15 days) comprising different ship-to-shore distances, different levels of aircraft attrition, and different footprints of mobile logistics forces deployed ashore. His model optimizes the number of aircraft sorties carrying only a specific cargo. It also attempts to utilize all available CH-53E sorties, with the MV-22 aircraft delivering the remaining supplies. Finally, the LCACs are incorporated into delivering all remaining supplies that cannot be delivered by air.

Marine Captain William Lambert's thesis [Lambert (2001)] developed an Air Plan Construction Heuristic to expedite the planning and scheduling of the aviation portion of STOM. This heuristic attempts to minimize the time required to deliver all serials ashore, subject to aircraft availability but without modeling deck spots explicitly and the capacity of LZs ashore. This thesis is currently restricted for distribution.

Our thesis uses the previous work on STOM and Sea-Based Logistics to form a more comprehensive model that considers the intricate details associated with ship-board flight operations, flight operations in general, and the inherent constraints that other factors such as attack aircraft and attack helicopter sorties bring to the problem. This thesis acknowledges the ability to plan using discrete analysis, however, key constraints such as deck cycle times, limited crew day (both aircrew and flight deck crew), limited deck spots, refueling considerations, and other similar necessities create a very dynamic environment that is best suited to optimization modeling.

II. MODEL DEVELOPMENT

A. METHODOLOGY FOR FORMULATION

Developing a model that emulates all the details of every operation that a modern-day MEU may encounter would take extraordinary amounts of computational resources. The operational flexibility of any one MEU makes constructing a model that incorporates every possible situation virtually unachievable. Therefore, the development of this thesis assumes (via Major Hagan's thesis) that the "enabling force" employment will require the greatest amount of support ashore. By formulating a model that attempts to minimize the amount of supplies that go undelivered, the scheduling of aircraft sorties is optimized in this sense. Using this information, we can derive which aircraft mix is the most advantageous (smallest unmet demand) throughout a spectrum of ARG ship-to-objective ranges. Our model will be called the Assault Support Optimization Model (ASOM).

There are five crucial elements in ASOM: a feasible aircraft mix, a ground unit ashore and its subsequent sustainment requirements, naval shipping, and landing zones. This section provides a brief overview of each of these inputs.

Although a MEU can deploy with many mixes of aircraft, this thesis will address those that, when combined with aircraft currently assigned to a MEU, still allow the freedom to reposition aircraft and conduct flight operations. The assignments ensure that, with aircraft either stowed in the Hangar Deck (the deck immediately below the LHD's flight deck) or on the aircraft slash line (the starboard side of the flight deck), the port side of the flight deck remains clear. For the basis of this study, and due to actual space limitations aboard the LHD, there are four pairs of MV-22/CH53E assignments that will be analyzed. Table 1 provides the four mixes and an overview of the actual area that each mix occupies. This, when compared to the current aircraft assignment, illustrates the substantial increase of space that the MV-22 will require when deployed aboard the ARG.

MEU Feasible Aircraft Allocations¹ and Space Utilization				
Mix	Area (folded)²	CH-53E	MV-22	Notes
1	19,776 sqft	4	12	4 AH/UH positioned on LPD
2	20,336 sqft	6	10	4 AH/UH positioned on LPD
3	20,896 sqft	8	8	4 AH/UH positioned on LPD
4	21,456 sqft	10	6	4 AH/UH positioned on LPD
-	13,872 sqft	4	12 CH-46E	Current MEU Assignment

Table 1. MEU Feasible Aircraft Allocations

- Notes
1. Although CH-53 & MV-22 aircraft assignments may change, the ARG is assumed to have 6 AH-1Z, 3 UH-1Y, 8 JSF-STOVL, and 2 U.S. Navy H-60 SAR aircraft.
 2. Space required without space allocated for movement of personnel between aircraft or the movement of aircraft between each other. Area is a total for all aircraft in mix. Area occupied when aircraft is folded.

Table 2 depicts the personnel and equipment that will come ashore during the operation. These figures were compiled from a number of sources, including Major Hagan’s thesis [Hagan (2000)], and the study conducted by the Center for Naval Analyses. [Magwood, J. et al. (1995)]. Slight changes of both publications were incorporated to more accurately emulate the STOM concept. For the purpose of this thesis, we assume that the AAVs and LAVs, along with other pertinent GCE equipment have come ashore via LCACs and self-deployed AAVs. Requirements determination will be addressed in chapter III.

MEU Force Structure (ashore)						
Personnel	HMMWV	MTRV Truck	Logistics Vehicle System	Light Armored Vehicles	M1A1 Tank	Advanced Assault Amphibious Vehicle
CE: 0	55	13	0	16	4	13
GCE: 1391						
ACE: 0						
TOT: 1391						

Table 2. MEU Force Structure

The third element into ASOM is U.S. Navy ships and the LZs within our objective areas. This thesis will utilize three U.S. Naval ships that are anticipated to deploy within the ARG for the next 10-20 years. These three ships are the LHD, LSD

and the LPD-17. Chapter III will provide a more in-depth discussion of each ship and their role within the ARG.

ASOM also incorporates two LZs, where assault support aircraft are required to deliver both internal and external cargo. These two LZs (“Raven” and “Hawk”), are identical in size, and are assumed to be 10nm from each other. Both LZs were placed at the same distance from the ARG to maintain simplicity within the model.

B. AIRCRAFT FLOW NETWORK

The model incorporates a time expanded network [Ahuja et al. (1993)]. A time expanded network consists of multiple replicas of a static network over time, which allows us to control the flow of sections of aircraft within the STOM environment. For ASOM, we have incorporated 30 20-minute time periods (10 hour operation) as a tool to control aircraft movement and fuel consumption. Figure 3 illustrates the static network at a specific time period. Within this network we have several “supply” nodes (deck spots on each of the three amphibious ships), and two “demand” nodes (the two landing zones). Several additional nodes are also present that allow aircraft to land, load cargo, refuel, hold or perform maintenance. For example, a section of two CH-53E aircraft may start the day at one of the LHD nodes that contains space for a section of aircraft. The next time period the aircraft is refueled or loaded with cargo. Once it is ready to deliver the cargo, the section departs the LHD deck spot node, flies through the LHD delta pattern node and travels directly to a LZ (or flies to one of the other ships within the ARG, possibly to load a different cargo). The delta pattern node is an aggregation of three actual delta patterns (overhead, starboard, and port) found aboard the LHD, with the purpose of holding an aircraft prior to landing. [U.S. Navy (1998)]. Once this section arrives at the LZ, it disembarks its load or personnel and returns for another load. If a section of aircraft arrives at a delta pattern and the landing spots on the ship are all occupied, the model allows the aircraft to loiter at this point until the spot becomes vacant. Nodes represent specific locations for the aircraft, whereas arrows reflect flying patterns between nodes. Each arrow is characterized, for example, by flying time (time to travel between nodes), and fuel consumption.

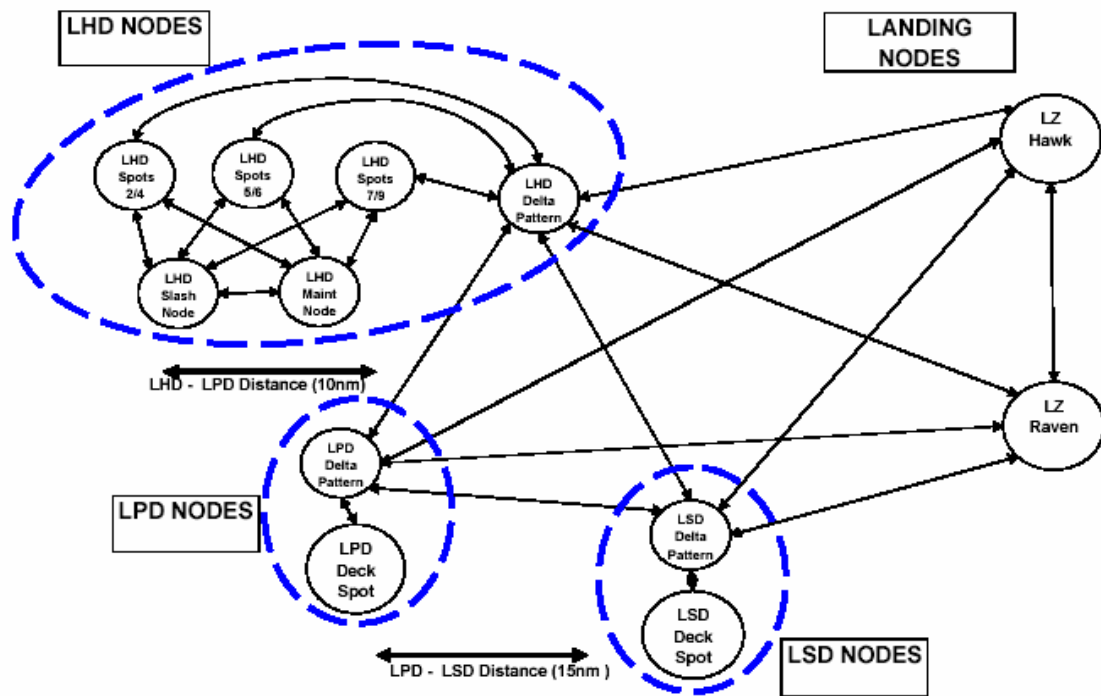

Figure 3. Static Network for Aircraft Allocation. Arcs are characterized by time to travel from the origin node to the destination node. Nodes are characterized by their capacity and operations (e.g. load, unload, refuel, and holding) that aircraft can perform while waiting. For the LHD Nodes, the “LHD Spots” include the actual deck spots aboard an LHD that were included in the respective node.

1. Network Nodes

As Figure 3 portrays, there are several nodes within the network that provide a variety of functions. To maintain consistency throughout the model, all landing zones and deck spots are aggregated in size to allow sections (flights consisting of two aircraft) of aircraft to land and take-off, vice single aircraft. This allows the model to accurately portray shipboard operations – where all flights are normally scheduled with at least two or more aircraft (sections). The following paragraphs define each node within the network. A basic premise is that each node’s size constraint is based on the size of a section of aircraft. The same also holds true with fuel burn rates, load capacities and minimum fuel requirements.

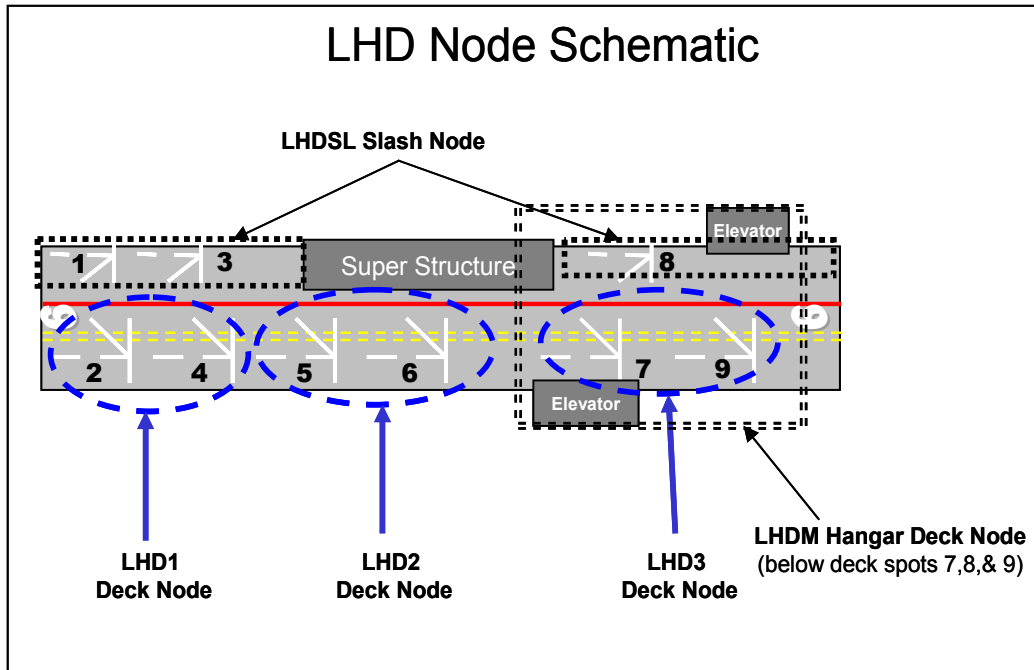

Figure 4. LHD Specific Network Nodes. Illustrates aggregation of deck landing spots into nodes with a capacity of two aircraft (one section).

a. LHD, LSD, LPD Deck Spots

Aboard the LHD, deck spots are locations on the flight deck (port side) that aircraft are required to land and takeoff from, and each LHD node represents two actual landing spots (Figure 4). Aboard the LPD and LSD, deck spots are modeled in the same manner as the LHD, however, these ships have only one deck spot node.

b. LHD, LSD, and LPD Delta Pattern Nodes

Although there are many usable aircraft holding patterns available for each ship of the ARG, we have aggregated them into one useable pattern per ship: the “delta pattern”. These patterns have two purposes: the first is to function as a type of control point which aircraft pass through to takeoff and land, and secondly, it acts as a holding point for aircraft that wish to land, but must wait for a landing spot to come available. In this model, all flights to and from a deck spot must pass through this pattern enroute to other ships or landing zones.

c. Slash Line Node

The slash line node is located on the starboard portion of the LHDs flight deck, both fore and aft of the ships super-structure (the large steel structure located above

the deck). This area is merely a portion of the flight deck that is utilized to temporarily position aircraft between flights, and also where aircraft are stored when the Joint Strike Fighter is conducting flight operations (takeoff).

d. Hangar Deck Node

This node is located below the flight deck of the LHD. A majority of all extensive aircraft maintenance is completed at this node. It also serves as a storage area for aircraft that cannot fit either on the deck spots or in the slash line.

e. Landing Zone Nodes

These two nodes have identical capacity for aircraft sections. The nodes are where the “demand” for the model is generated, in the form of both external and internal cargo.

Initial conditions assert that the aircraft (MV-22 and CH-53E) are pre-staged on the LHD. The model also ensures that these aircraft return to these same positions aboard the LHD at the end of the planning horizon (10 hours). The MEU has pre-positioned four AH-1Zs to the LPD in order to free LHD deck space for the operation. The remaining two AH-1Zs, three UH-1Y, two CH-60 Search and Rescue (SAR) helicopters and six JSF aircraft remain aboard the LHD. To account for Close Air Support (CAS), escort, and command and control missions, the data contained in Table 3 was integrated into the model. As the table indicates, the JSF aircraft are airborne over a period of approximately 67% of the 10 hours. When these aircraft take off, all port side deck spots aboard the LHD are required to be clear (the JSF aircraft utilizes a short take-off profile). When landing, these same JSF aircraft require only one deck spot to land. Additionally, with the AH-1s and UH-1s, the same holds true, however, they will be positioned on the LPD prior to the commencement of the operations. All three types of aircraft, like the MV-22 and CH-53E within this model, are assumed to fly in sections.

CAS/Escort Aircraft Deck Spot Utilization					
JSF-STOVL			AH-1Z/UH-1Y		
	Take off	Land		Take off	Land
p1			p1		
p2			p2		
p3			p3	LPD1	
p4	LHD1,2,3		p4		
p5			p5		
p6			p6		
p7			p7		
p8		LHD2	p8	LPD1	
p9			p9		LPD1
p10	LHD1,2,3		p10		
p11			p11		
p12			p12		
p13			p13		
p14		LHD2	p14		LPD1
p15			p15		
p16	LHD1,2,3		p16		
p17			p17	LPD1	
p18			p18		
p19			p19		
p20		LHD2	p20		
p21			p21	LPD1	
p22	LHD1,2,3		p22		
p23			p23		LPD1
p24			p24		
p25			p25		
p26		LHD2	p26		
p27			p27		LPD1
p28			p28		
p29			p29		
p30			p30		
Flight Duration: 1:20			Flight Duration: 2:00		
CAS Coverage:67%			CAS/Esc Coverage:76%		

Table 3. Joint Strike Fighter and AH-1/UH-1 Deck Spot utilization. Time periods are denoted p1, p2,..., p30. Highlighted deck spot(s) in black indicate that they are unavailable for assault support aircraft operations at the time period indicated. In the case when the JSF departs the LHD, the entire port side of the flight deck is unusable for flight operations.

2. LHD Aircraft Flow

Aircraft aboard the LHD may move from a deck spot to the hangar deck, slash line or to the delta holding pattern, and vice versa. Aircraft can only fly to the landing zones and other ships via the delta pattern; this allows one central location where aircraft can hold if the node they are flying to is currently occupied. The same holds true as aircraft are transiting back to the LHD.

3. LPD and LSD Aircraft Flow

Aircraft aboard both the LPD and LSD may move to any other node via the appropriate delta pattern, as explained in the paragraph above.

C. ASSUMPTIONS

As was stated at the beginning of this chapter, ASOM cannot capture every aspect of an amphibious operation; therefore assumptions must be made to allow the model to solve the problem in a realistic timeframe.

1. Scenario

- The LCACs have delivered the LAVs, Tanks, other GCE vehicles ashore. Although LCACs were not incorporated into this thesis, their importance and capabilities are an important factor within OMFTS. Additionally, the AAVs are assumed to have self-deployed ashore.

2. Aircraft

- Aircraft are assumed to fly in sections (2 aircraft) within the entire network.
- The MV-22 will not have flight restrictions aboard the LHD concerning take-off and landing, i.e. the aircraft will be able to take off and land at any available deck spot (referring to actual deck spots 2, 4, 5, 6, 7, and 9).
- The MV-22 will only utilize vertical take-off and landing profiles. The weight limit that this constraint imposes is explicitly incorporated within ASOM.
- The JSF-VTOSL aircraft will be able to maintain 80 minutes between take-off and landing. The AH-1Z and UH-1Y will be able to maintain 120 minutes between take-off and landing.
- There is one complete crew assigned to each aircraft.
- The MV-22 has been authorized external loads of 15,000 pounds (dual point). Additionally, external loads may be transported at speeds up to 200 knots. This speed represents the objective value speed for the MV-22 [Healy (2002)].

- Weather is assumed to be Visual Flight Rules (3 miles visibility, and ability to remain clear of clouds), and sea-states are assumed to be within aircraft ship-board take-off and landing flight envelopes.

3. Ships

- Flight operations are restricted to ten hours per day on all ships within the ARG due to flight deck crews maximum ten hour day (not including 90 minutes for pre-flight operations and 90 minutes for post-flight operations). [MAWTS-1 (2000)].
- Distance between the LHD and the LPD remains constant at 10 nm. Similarly, the distance between the LPD and the LSD remains constant at 15 nm.

D. ASSAULT SUPPORT OPTIMIZATION MODEL (ASOM)

1. Indices (and sets)

$t \in T$	aircraft type	{CH-53E, MV-22}
$a \in A$	section of each aircraft type	{CH53_1,...,CH53_4,MV22_1,...,MV22_6}
$c \in C$	demand commodity	{ordnance, fuel, artillery, MREs, water, personnel}
$g \in G$	type of cargo delivery	{internal, external}
$p \in P$	20-minute time period	{1, 2,...,30}
$s \in S$	amphibious ship within the ARG	{LHD, LSD, LPD}
$n \in N$	node within the network	{LHD1, LHD2... LZR}
$N_s^S \subset N$	Deck spots on ship s that an aircraft can land on	
n_{LHD}^{Slash}	Aggregated Slash node on the LHD	
n_s^{Delta}	Starboard delta holding pattern for ship s	
$N^Z \subset N$	Landing zones	

n^{Maint} Node representing the LHD's hangar deck

$r = (n, n') \in R$ arc within the network

$$R^1 \subset R = \{(n, n') \mid n \in N_{LHD}^S, n' = n_{LHD}^{Slash}, \text{ or vice versa}\}$$

Set of all arcs between all three LHD deck spots to the slash line and vice versa

$$R^2 \subset R = \{(n, n') \mid n \in N_s^S, n' = n_s^{Delta} \text{ or vice versa, for } s \in S \}$$

Set of all arcs between every deck spot to the delta pattern and vice versa, on each ship

$$R^3 \subset R = \{(n, n') \mid n = n_s^{Delta}, n' \in N^Z \text{ or vice versa, for } s \in S \}$$

Set of all arcs between the delta patterns at each ship, to landing zones and vice versa

$$R^4 \subset R = \{(n, n') \mid n \in n_s^{Delta}, n' = n_{s'}^{Delta} \text{ or vice versa, for } s, s' \in S, s \neq s' \}$$

Set of all arcs between the delta patterns of any two ships

$$R^5 \subset R = \{(n, n') \mid n, n' \in N^Z \}$$

Set of all arcs between landing zones

$$R^6 \subset R = \{(n, n') \mid n \in N_{LHD}^S \cup \{n_{LHD}^{Slash}\}, n' = n^{Maint} \text{ or vice versa}\}$$

Set of all arcs between either an LHD deck spot or the slash line to hangar deck and vice versa

2. Parameters (and units)

$t(a)$ Aircraft type for section a (CH-53E, MV-22)

$demand_{nc}$ Demand of cargo c at landing zone $n \in N^Z$ (pounds)

pen_{nc}^U Per-unit penalty for demand of cargo c unmet at landing zone $n \in N^Z$ (penalty units/pound)

pen^x	Penalty assessed for movement between two nodes (negligible coefficient to discourage unnecessary movement of aircraft)
$avail_{sc}$	Binary indicator of whether cargo c is available on ship s
$size_n^N$	Node n width (feet)
$size_a^A$	Section a width (feet)
$time_{nn'}$	Time for aircraft type t to travel from n to n' where the arcs $(n, n') = r \in R$ (periods)
$capac_{tcg}$	Capacity of aircraft type t to carry cargo c , type g (pounds)
$totcapac_t$	Total capacity of aircraft type t including fuel onboard (pounds)
$tMaint_t$	Time that aircraft type t can fly without visiting a maintenance node (periods)
$tMax_t$	Maximum time that aircraft type t can fly on any day (periods)
$arcfcom_{tnn'}$	Fuel consumption by aircraft type t flying through arc $r = (n, n')$ (pounds)
$deltafcom_{tn_s^{Delta}}$	Fuel consumption by aircraft type t while orbiting in the Delta Pattern node, $n = n_s^{Delta}$ of ship s (pounds)
$fmin_t$	Minimum fuel load for aircraft type t (pounds)
$fmax_t$	Maximum fuel capacity for aircraft type t (pounds)
$ravail_t$	Rate factor for aircraft type t availability, $0 \leq ravail_t \leq 1$
n_a^o, n_a^F	Initial and final nodes for section a

3. Variables

$X_{ann'p}$	Binary variable that takes a value of 1 if section a starts movement from node n to node n' in period p and 0 otherwise
W_{anp}	Binary variable that takes a values of 1 if section a is waiting at node n in period p (loading, refueling, delivering or static) and 0 otherwise
L_{acgp}	Amount of cargo c type g loaded on section a in period p (pounds)
K_{acgp}	Amount of cargo c type g carried by section a in period p (pounds)
B_{ancgp}	Amount of cargo c type g unloaded by section a at node $n \in N^Z$ in period p (pounds)
U_{nc}	Unmet demand of cargo c at node $n \in N^Z$ (pounds)
E_{ap}	Fuel loaded on section a in period p (pounds)
F_{ap}	Existing fuel load on section a in period p (pounds)

4. ASOM Model Formulation:

$$(ASOM) \text{Minimize: } f(U, X) = \sum_c \sum_{n \in N^Z} pen_{nc}^U U_{nc} + \sum_a \sum_p \sum_{(n,n') \in R(n,n')} pen^X X_{ann'p}$$

Subject to:

$$L_{acgp} \leq capac_{t(a),cg} \sum_s \sum_{n \in N_s^S} avail_{sc} W_{anp} \quad \forall a, c, g, p \quad (1)$$

$$\sum_{n \in N^Z} B_{ancgp} \leq K_{acgp} \quad \forall a, c, g, p \quad (2)$$

$$B_{ancgp} \leq capac_{t(a),cg} W_{anp} \quad \forall a, n \in N^Z, c, g, p \quad (3)$$

$$K_{acgp} = K_{acg,p-1} + L_{acgp} - \sum_{n \in N^Z} B_{ancg,p-1} \quad \forall a, c, g, p > 1 \quad (4)$$

$$K_{acgp} \leq capac_{t(a),cg} \quad \forall a, c, g, p \quad (5)$$

$$\left(\sum_c \sum_g K_{acgp} \right) + F_{ap} \leq \text{totcapac}_{t(a)} \quad \forall a, p \quad (6)$$

$$W_{anp} + \sum_{n|(n',n) \in R, p \geq \text{time}_{t(a),n'n}} X_{an'n,p-\text{time}_{t(a),n'n}+1} = W_{an,p+1} + \sum_{n|(n,n') \in R} X_{ann',p+1} \quad \forall a, n, p < |P| \quad (7)$$

$$\sum_{p \in P} \left(\sum_{R^2 \cup R^3 \cup R^4 \cup R^5} \text{time}_{t(a),nn'} X_{ann'p} + \sum_{s \in S} W_{an_s^{\text{Delta}} p} \right) \leq t\text{Max}_{t(a)} \text{ravail}_{t(a)} \quad \forall a \quad (8)$$

$$\sum_{p \leq p' \leq p + t\text{Maint}_{t(a)}} W_{an^{\text{Maint}} p'} \geq 1 \quad \forall a, p < |P| - t\text{Maint}_{t(a)} \quad (9)$$

$$F_{ap} = F_{a,1} + \sum_{p' \leq p-1} E_{ap'} - \sum_{p' \leq p} \sum_{(n,n') \in R} \text{arcfcon}_{t(a),nn'} X_{ann'p'} - \sum_{p' \leq p} \sum_s \text{deltafcon}_{t(a),n_s^{\text{Delta}}} W_{an_s^{\text{Delta}} p'} \quad \forall a, p \quad (10)$$

$$E_{ap} \leq f\text{max}_{t(a)} \sum_s \sum_{n \in N_s^3 \cup \{n_s^{\text{Slash}}\}} W_{anp} \quad \forall a, p \quad (11)$$

$$f\text{min}_{t(a)} \leq F_{ap} \leq f\text{max}_{t(a)} \quad \forall a, p \quad (12)$$

$$\left(\sum_a \sum_p \sum_g B_{ancgp} \right) + U_{nc} \geq \text{demand}_{nc} \quad \forall n \in N^Z, c \quad (13)$$

$$\sum_a W_{anp} \text{size}_a^A \leq \text{size}_n^N \quad \forall n, p \quad (14)$$

$$W_{an_a^{\circ},1} = 1 \quad \forall a \quad (15)$$

$$W_{an_a^F|P} = 1 \quad \forall a \quad (16)$$

$$W_{an,1} = 0 \quad \forall a, n \neq n_a^{\circ} \quad (17)$$

$$W_{an|P} = 0 \quad \forall a, n \neq n_a^F \quad (18)$$

$$X_{ann',1} = 0 \quad \forall a, (n, n') \in R \quad (19)$$

$$X_{ann'|P} = 0 \quad \forall a, (n, n') \in R \quad (20)$$

$$K_{acg|p|} = 0 \quad \forall a, c, g \quad (21)$$

$$\text{All variables are non-negative} \quad (22)$$

$$\text{All } X, W \text{ variables are 0-1 binary} \quad (23)$$

The objective function minimizes $f(U, X)$, which represents the unmet demand at the landing zones. Additionally, a small penalty value for each aircraft movement between nodes ensures that there are no unnecessary movements between any two nodes within the network.

The first of six cargo constraint equations, (1), permits the loading of cargo only if the aircraft section is currently positioned on a ship that has that commodity aboard. Equation (2) ensures that the amount of cargo unloaded off the aircraft is less than or equal to the amount that was previously carried by the same aircraft. The next equation (3) guarantees that cargo unloading only occurs when the aircraft is located at the landing zone. Equation (4) is a cargo balance equation to ensure that the amount of cargo currently carried is equal to the cargo the section of aircraft had aboard in the previous period plus any cargo loaded in the current period minus any cargo unloaded in the previous period. Constraint (5) limits the maximum amount of cargo carried by any aircraft to the cargo capacity of that aircraft. Equation (6) guarantees that the cargo loaded plus any aircraft fuel is less than the total weight capacity of the aircraft.

The aircraft movement balance constraint is equation (7). This equation ensures that either the aircraft are moving or waiting at a node in a time period, but not both.

Equation (8) limits the total flying time per day, depending on the availability rate (mission capable or not mission capable). Similarly, equation (9) limits the consecutive flight time that an aircraft section can fly without visiting an LHD node for preventive maintenance.

Equation (10) is a fuel load balance equation that ensures that the fuel load plus the fuel loaded is greater than the fuel consumed. Equation (11) works in conjunction with equation (10) to ensure that fuel is loaded onto the aircraft (if required) whenever it lands on any deck spot within the ARG. Equation (12) limits the amount of fuel load on the aircraft to a minimum [due to Naval Air Training and Operating Procedures

Standardization (NATOPS) guidance] and a maximum (fuel tank capacity) amount of fuel.

Equation (13) gives us the value of unmet demand by taking the demand and subtracting the total amount of cargo unloaded to fill that demand.

Lastly, equation (14) limits the number of aircraft that can land, wait or otherwise “occupy” a particular node aboard any of the ships or at each of the landing zones.

Equations (15) through (20) are the “boundary conditions” that set the initial and final positions and movements of aircraft. Equations (15) and (16) guarantee that each aircraft is positioned on a deck spot, slash line or in the hangar deck during the first and last time periods of the day. Equations (17) and (18), additionally ensure that during the first and last time periods, aircraft are not at nodes other than those earlier assigned. Equations (19) and (20) then set the constraint that there are no sections of aircraft moving during the first and last time periods.

Equation (21) ensures that there is no cargo aboard any aircraft during the last time period of the day.

Finally, equations (22) and (23) establish the non-negativity of all the variables, along with the binary character of the “waiting” and “flying” decision variables.

E. METHODOLOGY FOR SOLVING THE MODEL

The General Algebraic Modeling System [Brooke et al. (1998)] (version 2.0.8.3 with Revision 117 module) incorporating the CPLEX solver [GAMS/CPLEX (2002)] (version 6.6.1) was utilized to solve the model. Computations were completed on Dell Computer Precision 340 Pentium-4, 2 GHz desk-top computers with 1 GB of Random Access Memory (RAM). Each run contained over 502,225 continuous variables and over 9,870 discrete variables. Unfortunately, a Branch and Bound (B&B) scheme to solve our model (ASOM) becomes inefficient with more than two sections of aircraft and more than ten time periods.

We now describe a general-purpose methodology that alleviates this difficulty by solving (ASOM) in a number of steps, each of which involves a sub-problem of smaller complexity than the original problem. The approach we use follows the so-called Fix-

and-Relax (F&R) methodology introduced by Dillenberger et al. (1994). See also Escudero and Salmeron (2002) and previous versions of this methodology by Brown et al. (1987), among others.

We present this methodology for the following pure 0-1 model that we refer to as IP (Integer Program) (the generalization to our mixed-integer program is immediate, since it would only add continuous variables to the model):

$$\mathbf{IP} : \min_{\mathbf{y}} \{ f(\mathbf{y}) : \mathbf{y} \in Y \cap \{0,1\}^n \}$$

For our model (ASOM), \mathbf{y} consists of the set of binary variables $W_{anp}, \forall a, n, p$ and $X_{ann'p}, \forall a, n, n', p$. Y is the set of constraints (1)-(22) and f is our linear objective function $f(U, X)$. Note that constraints (23) are explicitly represented in **IP** by $\{0,1\}^n$.

To generalize the exposition of the methodology, the components of \mathbf{y} are denoted $\mathbf{y}_1, \dots, \mathbf{y}_n$ (so n is the total number of binary variables in the original model). Let $V = \{1, 2, \dots, n\}$ be the set indices for those variables, and let V_1, \dots, V_k be a direct partition of the set V , that is, $V_i \subseteq V, \forall i = 1, \dots, k$, $V = \bigcup_{i=1}^k V_i$, and $V_i \cap V_{i'} = \emptyset, \forall i, i' = 1, \dots, k | i \neq i'$.

The cardinality of each V_i is denoted $|V_i| = n_i$, therefore $n = \sum_{i=1, \dots, k} n_i$. Problem **IP** can be rewritten as:

$$\begin{aligned} \mathbf{IP} : \quad & \min_{\mathbf{y} \in Y} f(\mathbf{y}) \\ & \text{s.t. } \mathbf{y}_j \in \{0,1\}, \forall j \in V_i, i = 1, \dots, k \end{aligned}$$

In the partition selected for our problem, for a given period p , V_p comprises all the variables of type $W_{anp}, \forall a, n$ and $X_{ann'p}, \forall a, n, n'$ (i.e., all the variables associated with period p).

The F&R framework solves the following sequence of mixed-0-1 sub problems (hereafter *stages*) denoted \mathbf{IP}^r , for $r=1, \dots, k$:

$$\begin{aligned}
\mathbf{IP}^r : \quad & \min_{y \in Y} f(y) \\
& \text{s.t.} \begin{cases} y_j = \hat{y}_j, \forall j \in V_i, i = 1, \dots, r-1 & (\text{if } r > 1) \\ y_j \in \{0, 1\}, \forall j \in V_r \\ y_j \in [0, 1], \forall j \in V_i, i = r+1, \dots, k & (\text{if } r < k) \end{cases}
\end{aligned}$$

where the values \hat{y}_j for $j \in V_i, i = 1, \dots, r-1$ in stage $r > 1$ are retrieved from the solution to problems $\mathbf{IP}^1, \dots, \mathbf{IP}^{r-1}$, respectively. Since only a reduced subset of (non-fixed) 0-1 variables are kept integer at each stage r , \mathbf{IP}^r can be solved more efficiently than the original IP.

In particular, in our model (ASOM), we will start by relaxing the binary constraints for all the variables but those associated with period one. This allows us to easily obtain a “what-to-do-first” solution. These integer variables are then fixed at the second stage, where only those variables associated with the second period are deemed integer. We follow this cascade process until the variables for the last period, $p = |P|$, are set to integer values.

In short, our model (ASOM) is divided into $k = |P|$:

$$\begin{aligned}
\text{ASOM}^p : \quad & \min f(U, X) \\
& \text{s.t.} \begin{cases} \text{equations (1)-(22)} \\ W_{anp'} = \hat{W}_{anp'}, \forall a, n, p' = 1, \dots, p-1 & (\text{if } p > 1) \\ X_{ann'p'} = \hat{X}_{ann'p'}, \forall a, n, n', p' = 1, \dots, p-1 & (\text{if } p > 1) \\ W_{anp}, X_{ann'p} \in \{0, 1\}, \forall a, n, p \\ W_{anp'}, X_{ann'p'} \in [0, 1], \forall a, n, n', p' = p+1, \dots, |P| & (\text{if } p < |P|) \end{cases}
\end{aligned}$$

If we let $V^*(\text{ASOM})$ denote the optimal objective function value for our original model, and we also let $\underline{V}(\text{ASOM})$ and $\bar{V}(\text{ASOM})$ denote a lower bound and an upper bound on that solution, respectively, the F&R algorithm is as follows:

F&R(ASOM): Fix-and-Relax Algorithm for model (ASOM)

Input: Partition V_1, \dots, V_k , where $k = \text{number of periods} = |P|$, and each V_p contains exactly all the binary variables associated with period p :

$$V_p = \{\text{indices } (a, n, p) \text{ for } W \text{ variables}\} \cup \{\text{indices } (a, n, n', p) \text{ for } X \text{ variables}\}$$

Step 1: Set $p=1$ and solve $(ASOM^p)$.

If $(ASOM^p)$ is infeasible, STOP: “Problem $(ASOM)$ is infeasible”.

Otherwise, set $\underline{V}(ASOM) = V^*(ASOM^p)$.

Step 2: If $p=k$, set $\bar{V}(ASOM) = V^*(ASOM^k)$ and STOP: “Problem $(ASOM)$ is feasible”.

Otherwise, increase p by 1.

Step 3: Solve $(ASOM^p)$.

If $(ASOM^p)$ is infeasible, STOP: “Problem $(ASOM)$ status is unknown”.

Otherwise, go back to Step 2

Output: IP status (“Infeasible”, “Feasible” or “Unknown”). If status is

“Feasible”, the best lower and upper bounds that have been found for the optimal solution are $\underline{V}(ASOM)$ and $\bar{V}(ASOM)$, respectively.

As indicated in Step 3, F&R(ASOM) has the potential to fail. This may occur if $(ASOM^1)$ is feasible but, at some stage $p > 1$, the associated problem $(ASOM^p)$ becomes infeasible. In this situation, F&R(ASOM) is unable to recognize if the infeasibility is due to the fact that (a) ASOM is actually integer-infeasible (but continuous-feasible), or (b) $(ASOM)$ is integer-feasible, but the cascade fixing procedure (which is an estimate of the true optimal value of the variables) makes $(ASOM^p)$ infeasible.

In our computational experience, this problem never occurred, but if it did, we may implement alternative versions of this algorithm that overcome this problem [Escudero and Salmeron (2002)].

Notice also that $F\&R(ASOM)$ yields a relative gap equal to $(\bar{V}(ASOM) - \underline{V}(ASOM)) / \underline{V}(ASOM)$.

By employing the F&R methodology, we are able to obtain feasible solutions to our model, although they are still highly time consuming (see Table 4).

ASOM Computational Run Time		
Ship-Obj Dist	Aircraft Mix	Execution Time
50 nm	4 CH/12 MV	17.8 hours
	6 CH/10 MV	24.9 hours
	8 CH/8 MV	23.4 hours
	10 CH/6 MV	22.9 hours
75 nm	4 CH/12 MV	24.7 hours
	6 CH/10 MV	18.5 hours
	8 CH/8 MV	23.2 hours
	10 CH/6 MV	25.3 hours
100 nm	4 CH/12 MV	28.5 hours
	6 CH/10 MV	22.2 hours
	8 CH/8 MV	23.3 hours
	10 CH/6 MV	26.7 hours
125 nm	4 CH/12 MV	20.5 hours
	6 CH/10 MV	20.6 hours
	8 CH/8 MV	28.3 hours
	10 CH/6 MV	22.6 hours

Table 4. ASOM Computational Run Time

THIS PAGE INTENTIONALLY LEFT BLANK

III. DETERMINATION OF REQUIREMENTS

A. FORCE STRUCTURE TO BE SUPPORTED

(ASOM) utilizes a notional Marine Expeditionary Unit (approximately year 2010-2015) as the basic force structure, both to provide and receive assault support. Each MEU that deploys differs slightly in equipment and personnel levels due to MEU Commanding Officer's guidance, size and type of the Amphibious Readiness Group's (ARG) ships, and perceived or possible threat or mission to be encountered. Figure 5 illustrates the basic command structure and the decomposition of the MEU into the elements commonly found in most Marine Air-Ground Task Forces.

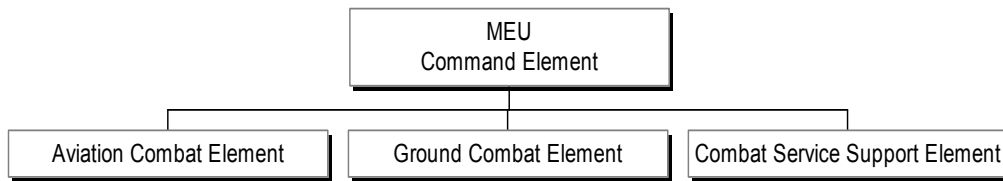

Figure 5. MEU Elements and Command Relationship (U.S. Marine Corps, 1998)

Within each element are various smaller detachments that are sourced from units within the Marine Expeditionary Force, from which the MEU receives the bulk of its support, personnel and equipment. Table 5 further decomposes these four elements, in addition to providing a typical embarkation plan aboard amphibious ships of the ARG. As stated in Chapter I, the STOM concept (in its purist form) envisions the GCE as the only element maneuvering ashore, while the remainder of the MEU provides support from the ARG (termed Sea-Based Logistics [SBL]).

Marine Expeditionary Unit Breakdown and Ship Assignments	
Marine Expeditionary Unit Element	Ship
Command Element (CE) - Force Reconnaissance Platoon - Radio Bn Detachment - Communications Detachment - Intel Bn Detachment	LHD
Ground Combat Element (GCE) - H&S Company - Rifle Company (3) - Weapons Company - LAR Company - AAV Platoon - Artillery Battery	LHD/LSD/LPD

Marine Expeditionary Unit Breakdown and Ship Assignments	
Marine Expeditionary Unit Element	Ship
-Combat Engineer Platoon -Tank Platoon -Scout Sniper Platoon - Recon Platoon -Tow Section	
Aviation Combat Element (ACE) -Composite Squadron - Light Anti-Air Defense (LAAD) Detachment	LHD/LSD
Combat Service Support Element (CSSE) - Headquarters - Supply - Health Services - Transportation Support - Military Police - Communications - Engineers - Maintenance	LHD/LSD/LPD

Table 5. MEU Ship Assignments [U.S. Marine Corps (1998)]

In the recent past (aside from operations in Afghanistan), a majority of MEUs have deployed with a typical composition of aircraft. This unit is identified as a composite squadron. The aircraft assigned to this composite squadron, as well as U.S. Navy helicopters assigned to the ARG are:

- 4 AH-1W Attack Helicopters
- 3 UH-1N Utility Helicopters
- 6 AV-8B Fixed-wing attack aircraft
- 12 CH-46E Medium Lift Helicopters
- 4 CH-53E Heavy Lift Helicopters
- 2 CH-46D Search and Rescue Helicopters (U.S. Navy)

ASOM uses this mix of aircraft as an initial baseline, tailoring it according to the study performed by Marine Aviation Weapons Training and Tactics Squadron One (MAWTS-1). [MAWTS-1 (2000)]. This thesis utilizes information contained in this study to form the composite squadron used with ASOM. The aircraft of this squadron include:

- 6 AH-1Z Attack Helicopters (replaces the AH-1W)
- 3 UH-1Y Utility Helicopters (replaces the UH-1N)
- 6 JSF-STOVL Joint Strike Fighter – Short Take-off, Vertical
 Landing, Fixed-wing attack aircraft
- MV-22 Medium Lift, Tiltrotor Aircraft
- CH-53E Heavy Lift Helicopter

The U.S. Navy is currently in the process of replacing the ageing CH-46D search and rescue aircraft aboard the ARG with CH-60S helicopters. This change has also been incorporated into ASOM. Although these aircraft are not included in potential assault support assets, they do occupy space aboard the LHD, and thus play an important role when deriving our formulations. In this sense, we limited available deck spots (corresponding to the type aircraft, flight profile [takeoff or landing], and time period) that our MV-22 and CH-53E aircraft could utilize.

MEUs of the future are anticipated to deploy with both the CH-53E and the MV-22. The anticipated proposal for the CH-46E is to replace it, one-for-one, with the MV-22. [MAWTS-1 (2000)]. MEUs are also anticipated to continue deploying with four CH-53E.

B. CLASSES OF SUPPLY

The GCE of the MEU will generate the demand for supplies of which ASOM will attempt to sustain. The Marine Corps organizes these supplies into categories identified as class types that cover a broad range of commodities within each class. These classes of supply are:

- I. Subsistence (MREs and Water)
- II. Individual Equipment
- III. Petroleum, Oil and Lubricants
- IV. Construction Material
- V. Ammunition
- VI. Personal Demand Items
- VII. Major End Items

- VIII. Medical Supplies
- IX. Repair Parts
- X. Non-military Program Material

(ASOM) could conceivably include every class of supply, however, this increase in detail corresponded to an increase in computational time. The benefits (more realistic model) did not correspond to an overall large increase in the pounds of supplies demanded. Thus, these classes of supply were excluded from the model, and we only examine that demand which falls in the following classes of supply (with actual commodities delivered listed within parentheses), in addition to personnel and artillery movement requirements. As the Center for Naval Analysis study [CNA (1995)] concluded, these classes of supply represent 98%, by weight, of all resupply requirements.

- Class I - Subsistence
(MREs and Water)
- Class III - Petroleum, Oil and Lubricants
(JP-5 Fuel for GCE equipment)
- Class V - Ammunition
(GCE requirements only)

C. SUPPORTING ASSETS

1. Shipping

ASOM utilizes the U.S. Naval amphibious ships that are assumed to remain in the naval fleet through the next 10 to 20 years, in addition to the employment of the new LPD-17 San Antonio class amphibious transport ship. The LHD (Figure 6) will remain the centerpiece of the ARG, with the Commander, Landing Force (CLF, a U.S. Marine Corps Colonel) and the Commander, Amphibious Task Force (CATF, a U.S. Navy Captain) both aboard. Table 6 provides a general mission overview of each ship of the ARG modeled in ASOM



Figure 6. Wasp Class LHD-6, USS Bonhomme Richard [U.S. Navy (2002)]

Ships of the Amphibious Readiness Group (utilized in ASOM)				
Quantity	Ship	Class	Name	Mission
1	LHD	Wasp	Amphibious Assault Ship (Multipurpose)	Embark, deploy, and land elements of a Marine landing force in an amphibious assault by helicopters, landing craft, amphibious vehicles, and by combinations of these methods
1	LPD	San Antonio	Amphibious Transport Dock	
1	LSD	Whidbey Island	Dock Landing Ship	Transport and launch loaded amphibious craft and vehicles and embarked personnel in amphibious assaults by landing craft and amphibious vehicles

Table 6. Ships of the Amphibious Readiness Group utilized in ASOM [U.S. Marine Corps (2001)]

2. Aircraft

Although ASOM accounts for both JSF-STOVL and AH/UH-1 aircraft sorties, the analysis is focused on both the MV-22 Tiltrotor medium lift (Figure 7) and CH-53E heavy lift aircraft (Figure 8).



Figure 7. MV-22 on the flight deck of an LHD [U.S. Navy (2002)]

a. MV-22 Osprey

The MV-22 is a tiltrotor aircraft that combines the Vertical Takeoff and Landing (VTOL) capabilities of a helicopter with the speed, range, and service ceiling of a turboprop airplane. [U.S. Navy (2000)]. The MV-22 is also capable of aerial refueling. The missions that the MV-22 is currently expected to fill are:

- Medium lift assault support
- Tactical Recovery of Aircraft and Personnel (TRAP)
- Emergency evacuation
- Logistics support ashore
- Long range logistics support
- Medical Evacuation

b. CH-53E Super Stallion

The CH-53E is a three engine, single rotor heavy lift helicopter designed for the transportation of heavy equipment and supplies. With a maximum gross weight of over 73,000 pounds with an external load, the CH-53E is capable of retrieving another CH-53E at a range of 20nm. [U.S. Navy (2000)]. Similar to the MV-22, the CH-53E is

also capable of aerial refueling. The CH-53E can also accomplish those missions assigned to the MV-22, with the addition of heavy lift assault support.



Figure 8. A CH-53E aerial refueling above a LHD [U.S. Navy (2002)]

c. Lift Capacity

The capacity to lift personnel and supplies varies with each aircraft, its fuel load, and the ship-to-objective distance it must fly. The capacities were determined through a number of resources, including interviews with a CH-53E pilot [Ludlow (2002)], a MV-22 test pilot [Healy (2002)], and the Naval Air Training and Operating Procedures Standardization (NATOPS) manuals for both aircraft. Table 7 illustrates both the external and total lift capacities for each aircraft. These capacities were computed using maximum range configurations and standard day conditions for both aircraft. Several additional assumptions were used to determine range and fuel burn rates. For the MV-22 without an external load, 84% Nr (prop rotor speed), autoflaps settings, and airplane mode. For the MV-22 with an external load, nacelle angle (wing angle of attack) of 60 degrees, 100% Nr, and a flap setting of 40 degrees was used (see Table 8).

Assault Support Aircraft Airspeeds and Total Lift Capacity					
Aircraft	Airspeed (Int Load)	Airspeed (Ext Load)	Troop Lift Capacity	External Lift Capacity	Total Lift Capacity
CH-53E	130 knots	110 knots	36	36,000 lbs ¹	36,000 lbs ¹
MV-22	230 knots	165 knots ²	24	15,000 lbs ³	17,600 lbs ³

Table 7. Assault Support Aircraft Airspeeds and Total Lift Capacity [U.S. Navy (2000), Ludlow (2002), and Healy (2002)]

- Notes:
1. External lift capacity is dictated by fuel load and internal cargo weight. For a CH-53E, the maximum total weight (including external weight) allowed by NATOPS is 73,500 lbs. Subtracting a full fuel load of 15,500 lbs, the basic weight of 39,000 lbs (including crew, weapons and external lift gear), the maximum total weight that the aircraft can lift (with full fuel tanks) is approximately 19,000 lbs. For the purpose of this thesis, the formulation allows up to 36,000 lbs, and adjusts the fuel load according to expected load and ship-to-objective round trip distance.
 2. The objective external lift airspeed of the MV-22 is 200 knots, and constitutes the maximum airspeed allowed by aircraft design [Healy (2002)]. Actual airspeeds may vary according to type load and mission between 130 and 200 knots. For the purpose of this thesis, an average of 165 knots was used.
 3. External lift capacity of the MV-22 is anticipated to be rated at 15,000 lbs (Dual Point). [Healy (2002)]. The maximum total weight (including external weight) allowed by NATOPS is 52,600 lbs. Subtracting a full fuel load of 9,800 lbs, the basic weight of 35,000 lbs (including crew, weapons and external lift gear), the maximum total weight that the aircraft can lift (with full fuel tanks) is approximately 7,800 lbs. For the purpose of this thesis, the formulation allows up to 17,600 lbs, and adjusts the fuel load according to expected load and ship-to-objective round trip distance.

Assault Support Aircraft Lift Capacity (Range Dependent)¹				
Aircraft	50 nm	75 nm	100 nm	125 nm
CH-53E	24,875 lbs	22,312 lbs	21,750 lbs	20,187 lbs
MV-22	13,000 lbs	11,613 lbs	10,140 lbs	8,672 lbs

Table 8. Assault Support Aircraft Lift Capacity (Range Dependent)

- Note:
1. Assumes aircraft must maintain internal fuel for return trip if external load cannot be delivered. Although this is the maximum weight capacity, actual capacity varies by type of cargo, not to exceed the above values.

d. Operational Availability

Operational availability for the MV-22 was based on two factors. The new airframe and enhanced technology implemented within the aircraft. These factors will allow for fewer maintenance-related problems, and more expeditious repair times. ASOM utilizes an availability rate of 0.85 to account for these factors. [Hagan (1998)].

Operational Availability for the CH-53E is substantially less than the MV-22 due to the fact that the airframe, and technology used within the aircraft is decades

older than that of the MV-22. To account for these factors, an availability rate of 0.70 was utilized. [Frey (2000)].

e. Landing Zone, Deck Spot and Delta Pattern Limitations

The aircraft capacity of the landing zones, slash line, hangar deck, holding pattern and deck spots aboard each ship and the objective area provide one of the most stringent constraints within ASOM. In order to realistically model these limitations, the widths (completely folded) of both aircraft are utilized and assigned to each section of aircraft. The aforementioned nodes are then assigned a “size” according to the number of aircraft sections that can simultaneously occupy a node during any one time period. (Table 9). The delta pattern of each ship is constructed to accept an unlimited number of aircraft sections.

Aircraft Capacity of Nodes within ASOM¹										
	LHD Deck1	LHD Deck2	LHD Deck3	LHD Slash-line	LHD Hangar Deck	LSD Deck1	LPD Deck1	LZ Raven	LZ Hawk	Delta Pattern (all)
CH-53E	2	2	2	8	6	2	2	2	2	Any
MV-22	2	2	2	10	8	2	2	2	2	Any

Table 9. Aircraft Capacity of Nodes within ASOM [Dolan (2002) and Healy (2002)]

Note: 1. Quantity indicates aircraft capacity assuming only one type of aircraft is located within the respective node.

f. Fuel Constraints

The maximum internal fuel that each aircraft can accommodate was calculated based on the data contained in their respective NATOPS manuals. For the MV-22, this value is calculated assuming that both feed tanks, both sponson tanks and the aft sponson tank are filled to capacity. This results in a total of 9,849 pounds of JP-5 fuel (6.8 pounds per gallon). This aircraft is limited by NATOPS to land with no less than 1,200 pounds of fuel onboard. [U.S. Navy (2000)].

The CH-53E’s maximum fuel capacity is derived using the total of (three) internal and (two) external fuel tanks aboard the aircraft. Again, using JP-5 fuel, this amount is calculated at 15,484 pounds capacity. As with the MV-22, the CH-53E is

limited by NATOPS to land with no less than 1,200 pounds of fuel onboard. [U.S. Navy (2000)].

D. REQUIREMENTS

1. GCE Requirements

ASOM incorporates Ship-To-Objective Maneuver with the GCE of the MEU as the maneuver force. Maintaining a small footprint ashore is identified as one of the key characteristics of STOM, and therefore requires that the Aviation Combat and Combat Service Support Elements remain sea-based. For the purpose of this thesis, a majority of the Marines within the GCE are expected to be flown into objective areas. Concurrently, Light Armored Vehicles (LAV), M1A1 tanks and Advance Amphibious Assault Vehicles (AAAV) may also deploy ashore on LCACs or by AAAs. Other equipment, such as the High Mobility Multi-Wheeled Vehicles (HMMWV) and Medium Tactical Vehicle Replacement (MTVR), for example, may also come ashore on LCACs as required.

For the purpose of this thesis, the GCE units and corresponding equipment depicted in Table 10 were utilized to determine a realistic, assault-based requirement for supplies ashore. This ensures that there will always be some unmet demand and, by doing so, the chance of two or more aircraft mixes delivering the entire demand is eliminated, providing a quantitative measure of analysis. The total weight of these supply requirements was computed at 243,365 pounds. With the addition of the six Light-Weight 155mm howitzers (LW-155, the Marine Corps' M-198 successor) and the weight of the air inserted Marines (300 pounds per Marine), the total demand was computed at 557,165 pounds. This figure only took into account one artillery battery and one troop movement per day. Using Major Hagan's thesis [Hagan (1998)] as a basis for our force structure, we made slight modifications in order to maintain the intent of STOM. To accomplish this we reduced the Battalion Landing Team's (BLT) Headquarters and Service Company (H&S) personnel that went ashore to one-third of the total personnel assigned. Additionally, the AAAV Platoon, Tank Platoon, and Light Armored Reconnaissance (LAR) Company Marines were identified as personnel not requiring airlift, as they were tasked to arrive ashore either by AAAs or by lift provided on the ARG's LCACs.

MEU Ground Combat Element Daily Lift Requirements (pounds)

Not including personnel or artillery battery delivery

			Class I		Class III	Class V	
Unit	Total Marines Ashore	Marines Requiring Airlift	Rations ¹	Water ²	Fuel ³	Threat	Assault Rate
BLT ⁴	794	609	4,431	46,178	6,570	Inf-Hvy	14,643
AAAV Plt	47	0	262	2,744	7,270	Inf-Hvy	1,433
Artillery Btry	147	147	820	8,582	7,572	Inf-Hvy	95,600
Tank Plt	16	0	90	934	3,332	Arm-Hvy	1,000
LAR Co	138	0	770	8,056	8,126	Inf-Hvy	11,200
Scout Sniper Plt	8	8	45	467	-	Inf-Hvy	50
Recon Plt	24	24	134	1,401	-	Inf-Hvy	375
CE Plt	38	38	212	2,218	1,666	Inf-Hvy	7,200
Sub-Total	<i>1,209</i>	<i>826</i>	6,748 lbs	70,580 lbs	34,536 lbs	-	131,501 lbs

Table 10. MEU GCE Daily Lift Requirements (U.S. Marine Corps, 2001 and Center for Naval Analyses, 1995)

- Notes:
1. Three Meals, Ready-to-Eat (MRE) per Marine per day, at 1.86 pounds per MRE. [U.S. Marine Corps (2001)].
 2. Water consumption per day at 8.34 pounds/gallon, 7 gallons per Marine per day. [U.S. Marine Corps (2001)].
 3. JP-5, 6.8 pounds per gallon.
 4. Approximately two-thirds (181 Marines) of the BLT's Headquarters and Service Company remain aboard the ARG. Additionally, one infantry company deploys ashore aboard AAAVs.

To further enhance the model, the demand for the three classes of supply, personnel and artillery maneuvering were apportioned as per Table 11. The artillery battery is positioned at LZ Hawk, in addition to two-thirds of the GCE.

Demand for Commodities at Landing Zones (pounds)				
			Type Load	
Landing Zone	Commodity	Demand	Internal	External
LZ Hawk 505 Total Marines 276 - Airlifted 229 - LCAC or AAAV -Artillery Battery -AAAV Platoon -Cmbt Engr Platoon -1 Infantry Company -H&S Company (-)	Ordnance	105,837	X	X
	Fuel	17,802	-	X
	MRE	2,818	X	X
	Water	29,482	-	X
	Artillery	66,000 ¹	-	X
	Personnel ²	82,800	X	-
LZ Raven 704 Total Marines 550 - Airlifted 154 - LCAC -Tank Platoon -LAR Company -Recon Platoon -Scout Sniper Platoon -Weapons Company -2 Infantry Companys	Ordnance	25,664	X	X
	Fuel	16,734	-	X
	MRE	3,930	X	X
	Water	41,098	-	X
	Artillery	0	-	-
	Personnel ²	165,000	X	-
Total Demand		557,165 lbs		

Table 11. Demand for Commodities at Landing Zones. An “X” indicates that the commodity can be delivered by internal or external methods.

Note: 1. Six LW-155 Howitzers with an anticipated weight of the 11,000 pounds each (LW-155).
 2. Personnel Weight calculated at 300 pounds per Marine, including combat gear.

While the preceding table addresses the demand of supplies at the two landing zones, Table 12 provides an inventory of supply availability aboard the three ships of the ARG.

Commodities Available on ships within the ARG			
Commodity	Ship		
	LHD	LSD	LPD
Ordnance	X	X	X
Fuel	X	X	X
MRE	X	X	X
Water	X	X	X
Artillery	-	-	X
Personnel	X	X	X

Table 12. Commodities Available on ARG ships. An “X” indicates that the commodity is available on the ship.

ASOM utilizes the data provided in this chapter to ultimately provide an “optimal” schedule of assault support sorties while minimizing the demand that goes undelivered to the landing zones. This schedule takes into account the flight operations of both the JSF and AH/UH aircraft, availability of supplies aboard ships, demand of supplies at the LZs, availability of landing spots both at the LZs and aboard the ships, and the required fuel and time to transport these supplies. The result is sixteen quantities for unmet demand that will be analyzed in the following chapter.

THIS PAGE INTENTIONALLY LEFT BLANK

IV. RESULTS

This chapter will analyze the results extracted from multiple runs of (ASOM) for different aircraft mixes and ship-to-objective distances. Although the model allows us to prioritize specific cargoes by assigning different weights per unit of unmet demand, we have only explored the case where all cargoes have the same penalty. Thus, we assigned a value of one for all penalties, which means that total unmet demand is minimized. In particular, we will use the met demand as our basis of analysis.

A. ANALYSIS OF SHIP-TO-OBJECTIVE DISTANCES

In order to limit the computational time, each F&R stage is not solved to optimality, which may weaken the quality of the solution provided by the algorithm. Our results show the best solution obtained for each problem, but we cannot ensure that an inferior solution cannot be improved (or even outperform another solution) if more computational work is afforded.

1. 50nm Ship-to-Objective Distance

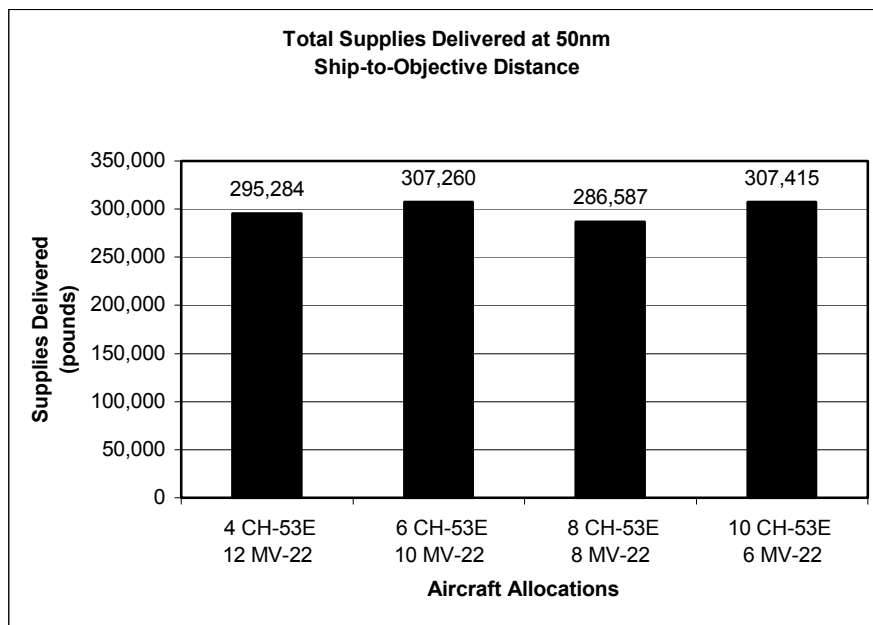

Figure 9. Total supplies delivered at 50nm ship-to-objective distance incorporating the four feasible aircraft allocations.

As Figure 9 illustrates, aircraft compositions of both 6 CH-53E/10 MV-22 and 10 CH-53E/6 MV-22 are within a few hundred pounds of each other, while the remaining two compositions have from 10,000 to 20,000 pounds less delivered supplies. For this distance, we would cautiously recommend the two top aircraft mixes (6 CH-53E/10 MV-22 or 10 CH-53E/6 MV-22).

2. 75 nm Ship-to-Objective Distance

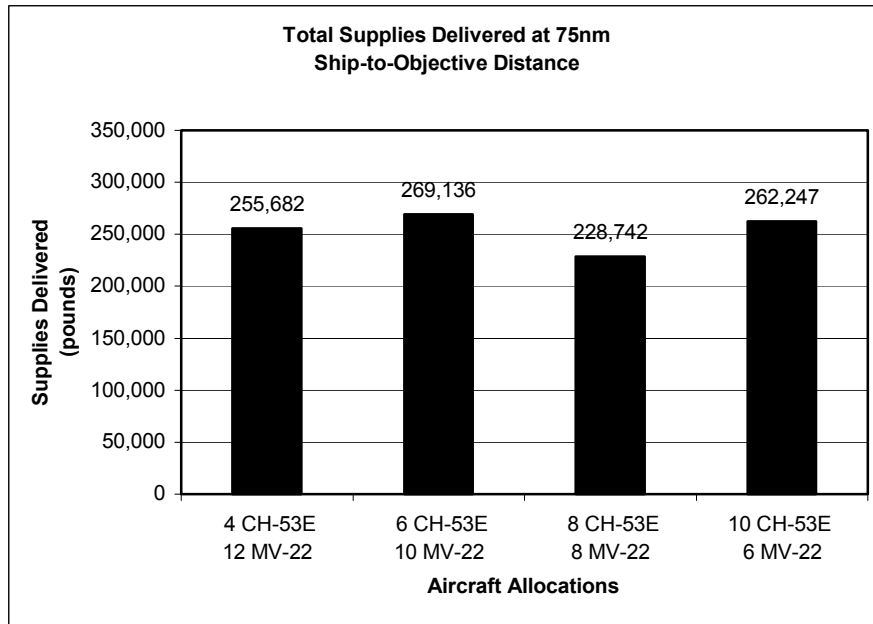

Figure 10. Total supplies delivered at 75nm ship-to-objective distance incorporating the four feasible aircraft allocations

For the 75nm ship-to-objective distance, our recommendation is the 6 CH-53E/10 MV-22 aircraft composition (Figure 10). At this distance, the airspeed advantage is now becoming apparent when we contrast these results with those at 50nm. Although the CH-53E can still lift approximately 12,000 more pounds than the MV-22 at this range, the ability of the MV-22 to deliver the loads faster becomes an overriding factor. This airspeed difference allows the recommended mix to take full advantage of its 10 MV-22s, and deliver the greatest amount of supplies, personnel and artillery.

3. 100nm Ship-to-Objective Distance

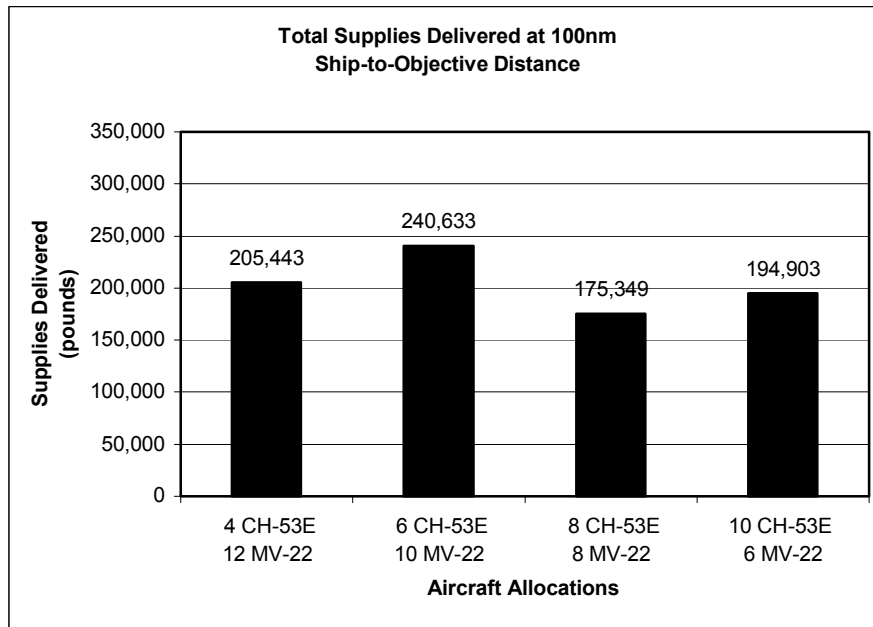

Figure 11. Total supplies delivered at 100nm ship-to-objective distance incorporating the four feasible aircraft allocations

As Figure 11 illustrates, the MV-22's airspeed advantage over the CH-53E allows the 6 CH-53E/10 MV-22 mix to provide the most support in the 100nm ship-to-objective range. The 100 knot difference in airspeed seems to make up for the large difference in lift capacity between the two types of aircraft. Essentially, the MV-22 aircraft can fly, within a fixed period of time, approximately twice as many sorties as the CH-53E. Our recommended mix at 100nm is the 6 CH-53E/10 MV-22 aircraft combination. The ability of this mix to be entirely stowed on the LHD's slash line (while 4 MV-22s and 2 CH-53Es are on the six available deck spots), allows this mix to produce superior results than that of the 4 CH-53E/12 MV-22 aircraft mix. This advantage translates into additional time available to deliver supplies. This occurs because the extra two time periods (40 minutes) required to reposition aircraft from the hangar deck to the deck spots and vice-versa at the end of the day is essentially lost delivery time.

4. 125nm Ship-to-Objective Distance

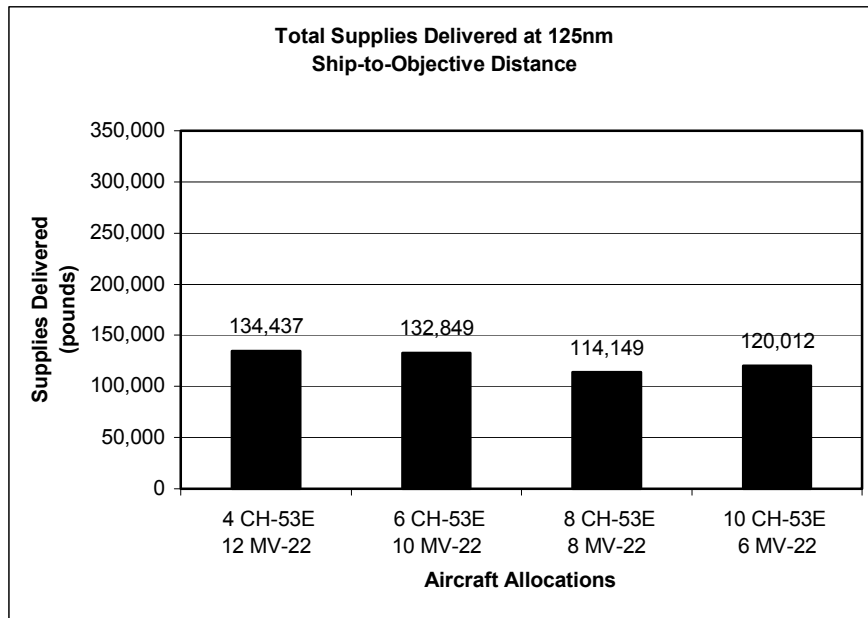

Figure 12. Total supplies delivered at 125nm ship-to-objective distance incorporating the four feasible aircraft allocations

Figure 12 illustrates the extreme effect that distance has on ASOM. Although the 4 CH-53E/12 MV-22 aircraft composition maintains a small advantage over the remaining mixes, the relative difference between all four mixes is small. The airspeed (MV-22) and lift capacity (CH-53E) advantage of each aircraft seem to offset each other, providing for the similar levels of delivered supplies. Additionally, the hangar deck advantage also addressed within the 100nm range becomes less of a factor. Recommending a preferred aircraft mix at this range is difficult without further analysis, as both the 4 CH-53E/12 MV-22 and 6 CH-53E/10 MV-22 mixes deliver similar results.

Additional analysis was accomplished by comparing supplies delivered per aircraft mix as a function of ship-to-objective distances. As expected, as distance increases, the amount of supplies delivered decreases at an approximate linear (proportional) rate.

1. 4 CH-53E and 12 MV-22 Aircraft

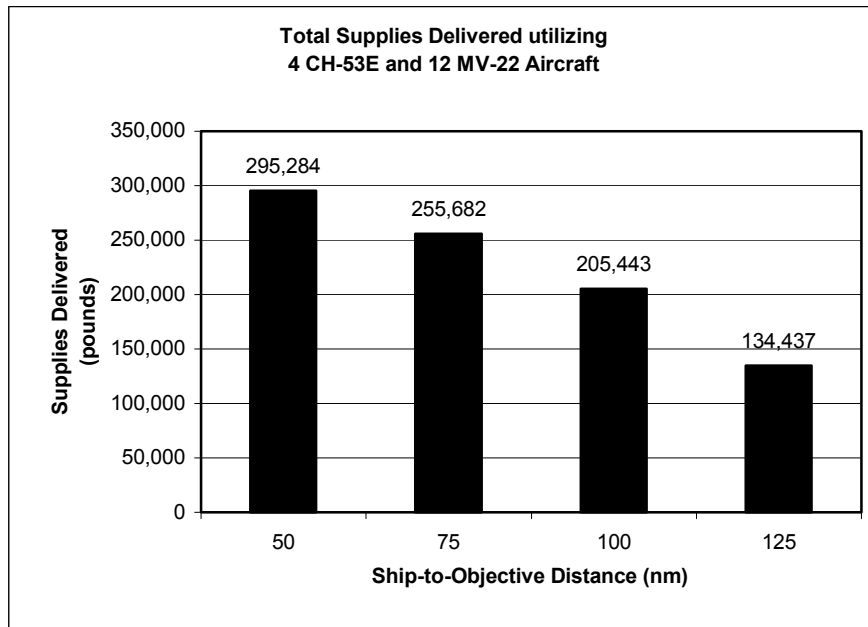

Figure 13. Total supplies delivered utilizing 4 CH-53E and 12 MV-22 at the four ship-to-objective distances.

2. 6 CH-53E and 10 MV-22 Aircraft

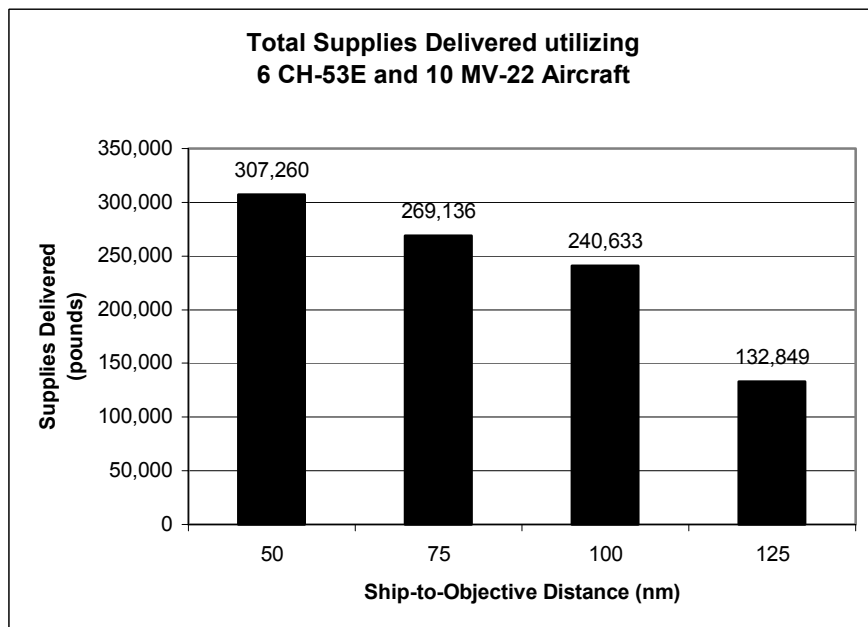

Figure 14. Total supplies delivered utilizing 6 CH-53E and 10 MV-22 at the four ship-to-objective distances.

3. 8 CH-53E and 8 MV-22 Aircraft

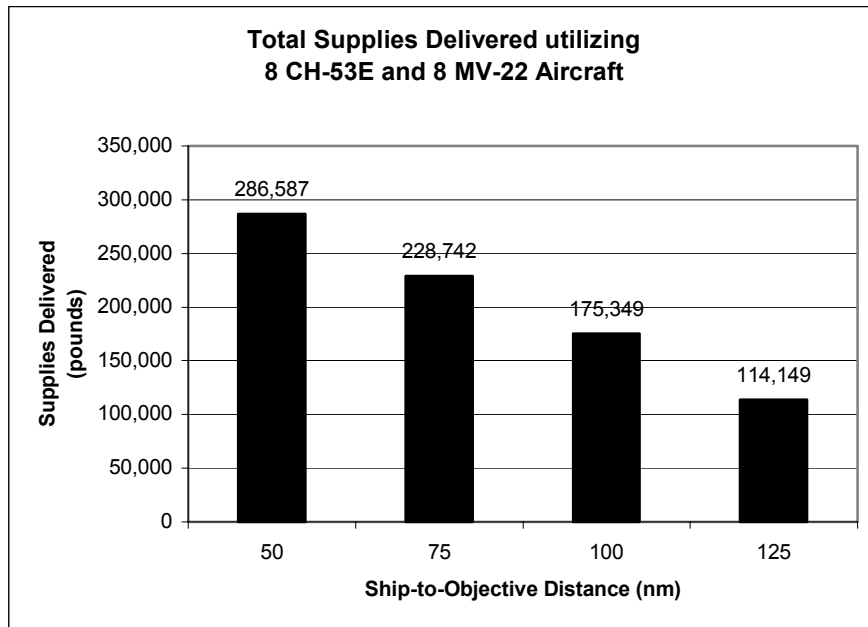

Figure 15. Total supplies delivered utilizing 8 CH-53E and 8 MV-22 at the four ship-to-objective distances.

4. 10 CH-53E and 6 MV-22 Aircraft

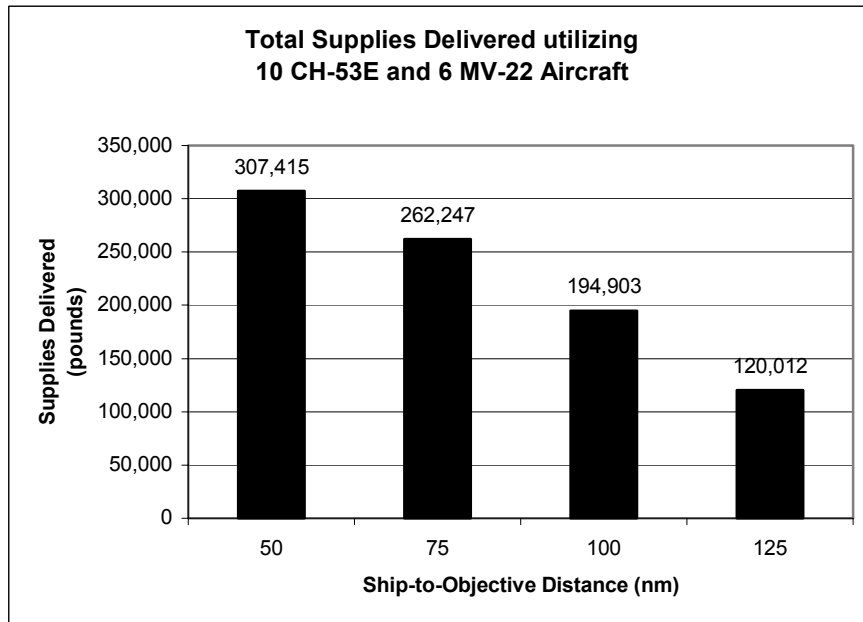

Figure 16. Total supplies delivered utilizing 10 CH-53E and 6 MV-22 at the four ship-to-objective distances.

V. CONCLUSION

A. OVERVIEW

OMFTS and STOM provide the U.S. Navy and Marine Corps with a tool to shape the battlespace and deliver combat power ashore quickly and efficiently. However, planning tools must follow to ensure MAGTF planners have at their disposal the means to accurately plan for the extremely dynamic environment that these concepts foster. The sheer velocity and size of assaults, coupled with the large increase in ship-to-objective distances, may not provide the time for planners to reconsider decisions previously made. Logistics, Aviation and the Ground Combat elements will be required to have at their disposal information and communication assets to maintain a high state of battlefield operational and logistical awareness. While the ASOM model included within this thesis is not all-encompassing, it does provide the basis for which further research maybe initiated.

Overall differences are not dramatic and we do not have further evidence that any aircraft combination clearly outperforms the others. According to the heuristic results obtained in this thesis, we would cautiously recommend a mix of 6 CH-53E and 10 MV-22 aircraft which, on average, seems to produce better results, and is always the best or second choice regardless of the ship-to-objective distance.

Of further interest is the analysis of the feasibility of delivering the requisite amount of supplies, not including personnel or artillery movements. As stated in Chapter III, this amount is computed at 243,365 pounds. At both the 50nm and 75nm range, a majority of the aircraft compositions are able to deliver this amount. As the ship-to-objective distances increase, however, the infeasibility of satisfying this demand becomes apparent. At 100nm, the 6 CH-53E/10 MV-22 is the only mix that is close to providing these supplies, but still falls short. At 125nm, the mixes are only able to satisfy approximately half the demand.

B. RECOMMENDATIONS FOR FURTHER STUDY

While ASOM is not without faults, the initial model has been developed. With further research, ASOM may provide the framework for a model that includes items that

were originally incorporated into the model. For example, due to the level of detail and the size of this model, the initial goal of achieving results for an extended period of time (15 days) were unattainable.

Further research may be able to produce a more efficient heuristic to assist in solving (ASOM). Once this has been achieved, additional constraints could be introduced, such as aircraft combat and maintenance attrition, loss of aircrews, MEDEVAC sorties, and possibly a wider range of aircraft mixes (other than sections of aircraft). The inclusion of LCACs into the model could also enhance the ability to use ASOM as planning tool, encompassing varying degrees of STOM operations. Additional scenarios could also be included within the model to examine the varying levels of required airlift assets required for each mission. The results from ASOM could also be compared by varying the aircraft capacity of the landing zones, as this aspect was one of the key limiting constraints for the delivery of supplies.

Additional questions remain as to the results if we prioritized cargo delivery, or imposed a minimum amount of each cargo to be delivered.

While the modeling of external and internal cargo operations (extended time of flight, time to unload cargo, fuel consumption rates, etc), was attempted, time constraints would not allow the implementation of a fully operating model. This should be attempted to provide more realistic results.

LIST OF REFERENCES

- Ahuja, R., Magnanti, T., and Orlin, J. (1993). *Network Flows: Theory, Algorithms and Applications*. New Jersey. Prentice Hall.
- Beddoes, M. (1997). *Logistical Implications of Operational Maneuver from the Sea*. Masters Thesis. Monterey, California. Naval Postgraduate School.
- Brooke, A., Kendrick, D., Meeraus, A., and Raman, R. (1998). *GAMS: A User's Guide*. GAMS Development Corporation. Washington, D.C..
- Brown, G., Graves, G. and Ronen, D. (1987). Scheduling Ocean Transportation of Crude Oil. *Management Science*, Vol. 33, No. 3, pp. 335-346.
- Dillenberger, C., Escudero, L., Wollensak, A. and Zhang, W. (1994). On practical resource allocation for production planning and scheduling with period overlapping setups. *European Journal of Operational Research*. Vol. 75, pp. 275-286.
- Dolan, T. (2002). E-mail, and telephone conversations with author, Winter 2001/Spring 2002. Camp Pendleton, California. I MEF Special Operations Training Group (SOTG).
- Escudero, L. and Salmeron, J. (2002). On a fix-and-relax framework for large-scale resource-constrained project scheduling. Working report I-2002-10. Operations Research Center, Universidad Miguel Hernandez, Elche, Spain. (Also in referee process).
- Frey, C. (2000). *An Evaluation of Sea-Based Sustainment of Forces*. Masters Thesis. Monterey, California. Naval Postgraduate School.
- GAMS/CPLEX (2002). <http://www.gams.com/solvers/solvers.htm#CPLEX>, accessed September, 2002.
- Hagan, R. (1998). *Modeling Sea-Based Sustainment of Marine Expeditionary Unit (Special Operations Capable) Operations Ashore*, Masters Thesis. Monterey, California. Naval Postgraduate School.
- Healy, S. (2002). E-mail correspondence with author, Spring/Summer 2002. NAS Patuxent River, Maryland. Naval Air Warfare Center Aircraft Division (NAWCAD).
- Lambert, W. (2001). *A Multi-commodity Network-based heuristic for the Ship-to-Objective Maneuver*. Masters Thesis. Monterey, California. Naval Postgraduate School. (Restricted Access)

- Ludlow, B. (2002). E-mail correspondence with author, Spring 2002. Quantico, Virginia. Marine Helicopter Squadron-1 (HMX-1).
- Magwood, J., Lyons, H., and Nance Jr., J. (1995). CRM 95-144 Project Culebra: Sea-Based Combat Service Support for Ship-to-Objective Maneuver (Supply and Transportation Analysis). Alexandria, Virginia: Center for Naval Analyses.
- Reitter, N. (1999). A Decision Support System for Sea-Based Sustainment Operations. Masters Thesis. Monterey, California. Naval Postgraduate School.
- Vaido, H. (1999). An Optimization Model for Sea-Based Supply of Bulk Fuel for a Deployed Marine Expeditionary Unit. Masters Thesis. Monterey, California. Naval Postgraduate School.
- U.S. Army (1994). Report by the Supreme Commander to the Combined Chiefs of Staff, on the Operations in Europe of the Allied Expeditionary Force, 6 June 1944 to 8 May 1945. Washington D.C.. Government Printing Office.
- U.S. Marine Corps (2000). A Marine Expeditionary Brigade in 2010. An Analysis of Operational Potential and Logistical Capabilities. Yuma, Arizona: Marine Aviation Weapons and Tactics Squadron One.
- U.S. Marine Corps (2001). Amphibious Ships and Landing Craft Data Book, MCRP 3-31B. Quantico, Virginia. Marine Corps Combat Development Command.
- U.S. Marine Corps (2001). Expeditionary Maneuver Warfare (Concept Paper), Quantico, Virginia. Marine Corps Combat Development Command.
- U.S. Marine Corps (2001). MAGTF Planner's Reference Manual. Quantico, Virginia. Marine Corps Combat Development Command.
- U.S. Marine Corps (1996). Operational Maneuver From The Sea (Concept Paper). Quantico, Virginia. Marine Corps Combat Development Command.
- U.S. Marine Corps (1998). Organization of Marine Corps Forces MCRP 5-12D. Quantico, Virginia. Marine Corps Combat Development Command.
- U.S. Marine Corps (1997). Ship to Objective Maneuver (Concept Paper). Quantico, Virginia. Marine Corps Combat Development Command.
- U.S. Navy (2000). CH-53E Naval Air Training and Operating Procedures Standardization (NATOPS) Flight Manual, A1-H53BE-NFM-000. Philadelphia, Pennsylvania. Naval Air Technical Services Facility.

- U.S. Navy (1998). LHA/LHD/MCS Naval Air Training and Operating Procedures Standardization (NATOPS) Manual, NAVAIR 00-80T-106. NAS North Island, California. Naval Air Technical Data and Engineering Service Command.
- U.S. Navy (2000). Preliminary MV-22B Naval Air Training and Operating Procedures Standardization (NATOPS) Flight Manual, A1-V22AB-NFM-000. NAS North Island, California. Naval Air Technical Data and Engineering Service Command.
- U.S. Navy (2002). U.S. Navy Web Site <http://www.navy.mil>. Accessed September, 2002.

THIS PAGE INTENTIONALLY LEFT BLANK

INITIAL DISTRIBUTION LIST

1. Defense Technical Information Center
Fort Belvoir, Virginia
2. Dudley Knox Library
Naval Postgraduate School
Monterey, California
3. Professor Javier Salmeron, Code OR/Sa
Department of Operations Research
Naval Postgraduate School
Monterey, California
4. Professor David Schrady, Code OR/So
Department of Operations Research
Naval Postgraduate School
Monterey, California
5. Marine Corps Representative
Naval Postgraduate School
Monterey, California
6. Director, Training and Education, MCCDC, Code C46
Quantico, Virginia
7. Director, Marine Corps Research Center, MCCDC, Code C40RC
Quantico, Virginia
8. Marine Corps Tactical Systems Support Activity (Attn: Operations Officer)
Camp Pendleton, California
9. Director, Studies and Analysis Division, MCCDC, Code C45
Quantico, Virginia
10. Mr. Nick Linkowitz, Head, Logistics Division Team
Installations and Logistics
Headquarters, U.S. Marine Corps
11. Deputy Chief of Naval Operations (Logistics)
Attn: LCDR Arthur Cimiluca, Code 421C
Washington, DC

12. Major Thomas Dolan
I Marine Expeditionary Force (SOTG)
Camp Pendleton, California
13. Mr. Bill Grenard
METRON
Solana Beach, CA
14. Major Michael J. Powell
Great Falls, Montana