

AD _____

Award Number: DAMD17-01-2-0051

TITLE: Devices for Emergency Hypothermia and Military
Applications

PRINCIPAL INVESTIGATOR: Ralph E. Gill

CONTRACTING ORGANIZATION: Biocontrol Technology, Inc.
Indiana, Pennsylvania 15701

REPORT DATE: September 2002

TYPE OF REPORT: Annual

PREPARED FOR: U.S. Army Medical Research and Materiel Command
Fort Detrick, Maryland 21702-5012

DISTRIBUTION STATEMENT: Approved for Public Release;
Distribution Unlimited

The views, opinions and/or findings contained in this report are those of the author(s) and should not be construed as an official Department of the Army position, policy or decision unless so designated by other documentation.

20021101 061

REPORT DOCUMENTATION PAGEForm Approved
OMB No. 074-0188

Public reporting burden for this collection of information is estimated to average 1 hour per response, including the time for reviewing instructions, searching existing data sources, gathering and maintaining the data needed, and completing and reviewing this collection of information. Send comments regarding this burden estimate or any other aspect of this collection of information, including suggestions for reducing this burden to Washington Headquarters Services, Directorate for Information Operations and Reports, 1215 Jefferson Davis Highway, Suite 1204, Arlington, VA 22202-4302, and to the Office of Management and Budget, Paperwork Reduction Project (0704-0188), Washington, DC 20503

1. AGENCY USE ONLY (Leave blank)	2. REPORT DATE September 2002	3. REPORT TYPE AND DATES COVERED Annual (1 Sep 01 - 31 Aug 02)
----------------------------------	----------------------------------	---

4. TITLE AND SUBTITLE Devices for Emergency Hypothermia and Military Applications	5. FUNDING NUMBERS DAMD17-01-2-0051
--	--

6. AUTHOR(S) Ralph E. Gill

7. PERFORMING ORGANIZATION NAME(S) AND ADDRESS(ES) Biocontrol Technology, Inc. Indiana, Pennsylvania 15701 E-Mail: rgill@biocontrol-tech.com	8. PERFORMING ORGANIZATION REPORT NUMBER
---	--

9. SPONSORING / MONITORING AGENCY NAME(S) AND ADDRESS(ES) U.S. Army Medical Research and Materiel Command Fort Detrick, Maryland 21702-5012	10. SPONSORING / MONITORING AGENCY REPORT NUMBER
---	--

11. SUPPLEMENTARY NOTES

12a. DISTRIBUTION / AVAILABILITY STATEMENT Approved for Public Release; Distribution Unlimited	12b. DISTRIBUTION CODE
---	------------------------

13. ABSTRACT (Maximum 200 Words) Ongoing research by the Safar Center for Resuscitation Research and others, indicates the need for the development of compact, mobile, and portable devices for the induction of therapeutic hypothermia. During the first year (1 September 2001-31 August 2002) we have developed the cooling requirements for the induction of mild (34 degrees C) to moderate (30 degrees C) and profound (10-20 degrees C) hypothermia in the average human body. We then researched the available literature for viable methodologies that could be used as a cooling means to incorporate into cooling devices for the induction of both mild and profound hypothermia. Computer modeling, mathematical analysis, and laboratory characterization were used to evaluate various concepts for the cooling means and the heat exchanger designs. Experimental prototypes of the selected methodologies were constructed and evaluated. From this work three cooling methodologies were selected for inclusion in the devices and we determined that existing blood heat exchangers do not have the capacities required for this application and we therefore must develop custom heat exchangers.

14. SUBJECT TERMS hypothermia, trauma, preservation, blood, pumping, cooling, devices	15. NUMBER OF PAGES 147
	16. PRICE CODE

17. SECURITY CLASSIFICATION OF REPORT Unclassified	18. SECURITY CLASSIFICATION OF THIS PAGE Unclassified	19. SECURITY CLASSIFICATION OF ABSTRACT Unclassified	20. LIMITATION OF ABSTRACT Unlimited
---	--	---	---

TABLE OF CONTENTS

Cover.....	1
SF 298.....	2
Introduction.....	4
Body.....	5
Key Research Accomplishments.....	13
Reportable Outcomes.....	13
Conclusions.....	13
Personnel.....	15
References.....	16
Appendices.....	17
Appendix A: Vortex Tube Analysis for the Hypothermia Project	
Appendix B: Evaluation of the Stirling Cycle as a Cooling Means	
Appendix C: Analysis of Pulse-tube and Thermo-acoustic Refrigeration	
Appendix D: Analysis of Magnetic Refrigeration	
Appendix E: Liquid Carbon Dioxide Evaluation Tests	
Appendix F: Analysis of Liquid Carbon Dioxide Phase Change Refrigeration	
Appendix G: Characterization of FridgeFreeze portable refrigerator/freezer	
Appendix H: Thermoelectric Cooler Performance Testing	
Appendix J: A Research Analysis of the Absorption Cycle Refrigeration	
Appendix K: Electrical Power for PortableHypothermia Devices	
Appendix L: Characterization of Dometic portable refrigerator/freezer	
Appendix M: Induction of Mild to Moderate Hypothermia via TEC Cooling	
Appendix N: TEC Cooling Device Performance as a Function of Input Power	
Appendix O: Characterization of Dometic portable refrigerator/freezer – Propane	
Appendix P: Mild-Moderate Hypothermia Induction Device	
Appendix Q: Profound Hypothermia Induction Device	

AWARD NO: DAMD17-01-2-0051

PRINCIPAL INVESTIGATOR: Ralph Gill, BSME

INSTITUTION: Biocontrol Technology, Inc.

TITLE: Devices for Emergency Hypothermia and Military Applications

Introduction:

During the past decades studies have shown in dogs with cardiac arrest that mild hypothermia, after prolonged normothermic no blood flow, can mitigate brain damage.^{1,2} The efficacy of the use of mild hypothermia was confirmed in recent clinical trials.^{3,4,5} Additionally, other studies included lowering the brain temperature to 10°C (profound hypothermia) to preserve the entire organism during no flow of up to 2 hours (suspended animation).^{6,7,8}

From these studies has arisen the requirement for two compact portable devices. First, for rapid induction of mild hypothermia under spontaneous circulation via venous or arterial shunt flow through a portable, cooled heat exchanger. Cooling devices and blood heat exchangers that are available do not have the capacities required to rapidly induce hypothermia nor are they compact enough to be portable. The second device is for use in transport vehicles, helicopters or field hospitals; will maintain a large volume reservoir of approximately 0°C fluid with a pump ready to be pumped into the aorta for the induction of profound hypothermia.

The first year of this effort involves development of the device requirements based on the required cooling capacities, researching available miniature blood pumps, evaluating heat exchanger concepts through calculations and or laboratory testing, and construction and testing of laboratory models of the techniques found to hold the most promise in meeting the requirements.

The ultimate objective is to design, develop, fabricate, and test devices suitable for performing the described functions.

Body:

1. Development of Requirements and Heat Loads

In collaboration with the Safar Center for Resuscitation Research (SCRR), develop and generate the operational and functional requirements for the devices described above. A preliminary device requirements document was developed those requirements are as follows.

1.1. Results of the data search for determination of heat loads

1.1.1 Functional given parameters supplied by SCRR

- Normal blood (body) temperature $T_b = 37^\circ\text{C}$
- Body temperature (mild hypothermia) $T_{\text{final}} = 34^\circ\text{C}$
- Blood return temperature $T_r = 10 \pm 5^\circ\text{C}$ (assume 10°C)
- Flow rate is 10% cardiac output $R_f = .500 \text{ l/min}$
- Average adult body weight **80 kg**
- Catheter bore x length **3mm dia x 1m**
- Profound hypothermia flush volume **20 liters (initial assumption)**
- Flush fluid temperature 0°C to 4°C
- Flush rate **2 liters/min**

1.1.2 Thermal and organ parameters resulting from literature search

- Blood density $\rho = 1.06 \text{ kg/l}$
- Blood viscosity $\mu = .04 \text{ poise } (.004 \text{ kg/m-sec})$
- Thermal conductivity of blood $k = .49 \text{ W/m-k}$
- Blood thermal capacity $C_{\text{blood}} = 3.8 \text{ kJ/kg-}^\circ\text{C}$
- Human body thermal capacity $C_{\text{body}} = 3.47 \text{ kJ/kg-}^\circ\text{C}$
- Metabolic heat generated at rest $q_m = 6.3 \text{ kJ/min}$
- Mass of human adult heart **400 grams**
- Mass of human adult brain **1400 grams**
- Mass of connecting blood vessels **300 grams (Heart & Brain)**
- Human tissue thermal capacity $C_{\text{tissue}} = 3.48 \text{ kJ/kg-}^\circ\text{C}$
- Thermal capacity of 5% saline $C_{\text{saline}} = 4.2 \text{ kJ/l}$

1.2.Device for Induction of Mild Hypothermia:

1.2.1 Description

The mild hypothermia procedure is intended to lower the core body temperature under spontaneous circulation, (shunt blood flow with or without use of a pump)—after cardiac arrest, during surgical procedures, after traumatic brain injury, in acute stroke, after spinal cord injury, etc. with spontaneous blood flow. The induction of mild hypothermia has been shown to decrease the damage to organs specifically the brain during low blood flow. Several access techniques for inducing mild hypothermia are available depending upon the specific situation and are discussed by SCRR, the variations do not materially affect the device design or configuration.

1.2.2 Preliminary device requirements (Appendix P)

- a) Capable of cooling blood in an extra-corporeal circuit from a temperature of 37°C to 10 ±5°C, (assume 10°C is the target temperature.) at a flow rate of approximately 10% of cardiac output (500ml/min).
- b) Access will be via. Catheters both inflow and outflow (veno-venous, arterio-venous) the catheters and cannula are not part of the device. The remaining extra-corporeal circuit is part of the device.
- c) The extra-corporeal circuit is a disposable tubing set containing the blood heat exchanger, tubing, connecting means, bubble trap, blood filter, and (depending upon the final pump configuration) the pump head. All blood-contacting components are to be non- clotting (heparin bonded) inside and out.

1.2.3 Other desirable attributes

- a) The device hardware, electronics, temperature controls, drive circuitry, cooling means, etc. will be packaged in such a manner that the weight and cubic volume is minimized. The size and weight is dependent upon the ruggedness required for transportability, the insulation volume required for efficient heat exchanger cooling, and

the cooling means concept used. Power input requirements compatible with rescue vehicles. (Appendix K)

- b) The device controls, software, readouts, etc. should be minimized consistent with functional requirements. (i.e. the operator interface should be minimized)
- c) The initial device should be movable within the hospital setting.

1.2.4 Calculations of the cooling means capacity required for mild Hypothermia

- Heat removal rate (cooling capacity): $Q_r = R_f \rho C_{\text{blood}} \Delta T$

Q_r = cooling capacity required

R_f = blood flow rate l/min

ρ = density kg/l

C_{blood} = thermal capacity kJ/kg-°C

ΔT = temperature drop through the heat exchanger

$Q_r = .5 \text{ l/min} * 1.06 \text{ kg/l} * 3.8 \text{ kJ/kg-}^\circ\text{C} * 27^\circ\text{C}$

$Q_r = 54380 \text{ kJ/min (907 W)}$

- Time to cool 80 kg body to 34°C assuming constant metabolic rate:

$t = Q / ((C_{\text{blood}} R_f \rho \Delta T) - q_m)$

$Q = (T_b - T_{\text{final}}) * 80\text{kg} * C_{\text{body}} = 3^\circ\text{C} * 80\text{kg} * 3.47 \text{ kJ/kg-}^\circ\text{C} = 833 \text{ kJ}$

$t = 833 \text{ kJ} / (((3.8 \text{ kJ/kg-}^\circ\text{C}) * 27^\circ\text{C} * .5 \text{ l/min} * 1.06 \text{ kg/l}) - 6.3 \text{ kJ/min})$

$t = \underline{17 \text{ min}}$ (see Fig. 1)

Body cooling time Vs flowrate
(Assumes 100% efficiency)

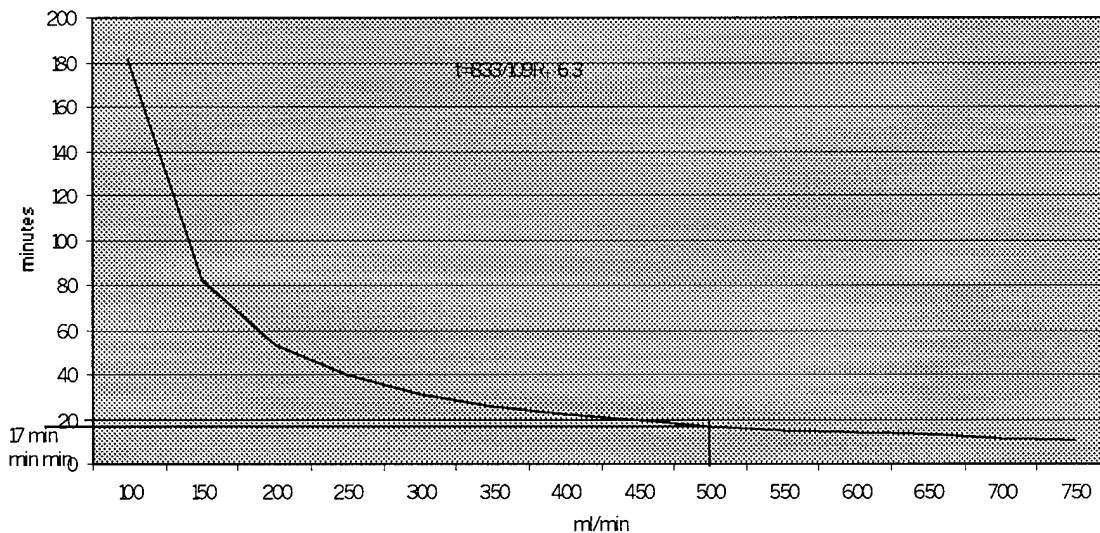
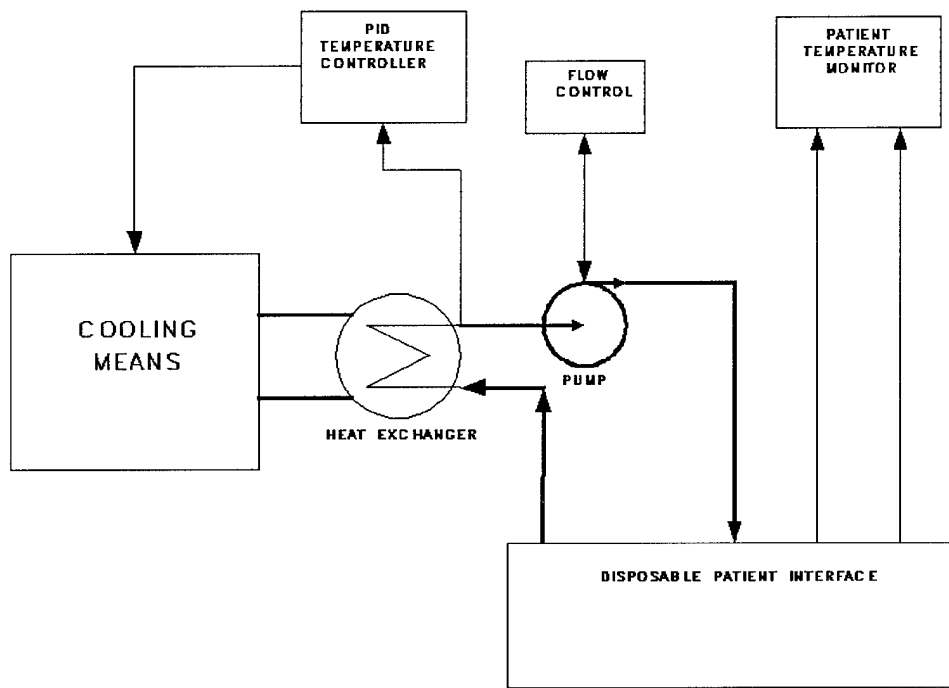

Fig. 1



Mild Hypothermia Conceptual
Flow Diagram

Fig. 2

1.3. Device for Induction of Profound Hypothermia

1.3.1 Description

Profound hypothermia is intended for use primarily in cases of trauma-induced exsanguination cardiac arrest. In these cases, which are considered unresuscitable by standard methods, the profound hypothermia (suspended animation), with or without drugs, is intended to preserve the organs for delayed resuscitation, organ repair, or organ harvesting.

The induction of profound hypothermia is accomplished by a rapid one way flush with a large volume of cold fluid via the thoracic aorta toward the heart and brain, with drainage from the right atrium.

1.3.2 Preliminary device requirements (Appendix Q)

- a) Maintain a large volume (20 liters) of pre-cooled sterile fluid at a temperature of -10°C to 4°C . (isotonic saline solution is presently

used, other fluids to be researched and or developed by SCCR or others)

- b) Deliver the fluid by means of a pump @1-2 liters/min via a disposable, sterile tubing set and a catheter with a bore diameter of 3mm. (the delivery catheter is not part of the device, the tubing and connecting means are part of a disposable set and will be included as part of the device)
- c) Device is for use in the hospital trauma emergency room setting and the power requirements are to be consistent with that available in the hospital.

1.3.3 Other desirable attributes

- a) The device weight should be minimized consistent with the intended use.
- b) The device controls, software, readouts, etc. should be minimized but remain consistent with functional requirements. (i.e. the operator interface should be minimized)
- c) The device should be movable within the hospital or mobile setting.

1.3.4 Time to cool the heart and brain via aortic cold flush directed to the heart and brain (Profound Hypothermia) ^{*†}

- Heat capacity of involved tissues $\cong 3.48\text{kJ/kg}\cdot^{\circ}\text{C}$
- Heart: 0.4 kg; Brain: 1.4 kg; Other: 0.3 kg (**Total mass 2.1 kg**)
- Thermal conductivity of organs (average) $k=.5\text{W/mK}$.014kj/min/in- $^{\circ}\text{C}$)
- Average organ to body: $\Delta T=(\Delta T_{\text{initial}} + \Delta T_{\text{final}})/2=23^{\circ}\text{C}$ (**assumes constant body temperature**)
- Mean total organ area/heat travel distance= $150\text{in}^2/3\text{in}=50$ in (estimated)
- Total heat absorbed by heart & brain: $Q_{\text{absorbed}}=(k)(50)(23)(t)=16t$
- Total heat to be pumped: $Q_T = (3.48)(2.1)(27)+(Q_{\text{absorbed}}) \cong 197\text{kJ}+16t$
- Heat capacity of 5% saline $\cong 4.22$ btu/L- $^{\circ}\text{C}$

* These calculations assume 100% efficiency for the heat transfer within the organs

† We are assuming a mid range flush temperature of 0°C

- Temperature of saline entering body = 0°C
- Temperature of saline leaving body = 10°C
- Then: $\Delta T = 10^\circ\text{C}$
- Heat that can be pumped: $Q_A \cong (4.22)(10)Rt \text{ kJ}$

R = flow rate (L/min)

Rt = volume (L) of saline used

- Then: $42.2Rt = 197 + 16t$
- For $R = 2 \text{ L/min}$
- **$t \cong 3 \text{ min}$**
- **$Rt \cong 6 \text{ L}$** total flush volume

1.3.5 Pumping capacity required for maintaining 20 liters of pre-cooled fluid at -10°C

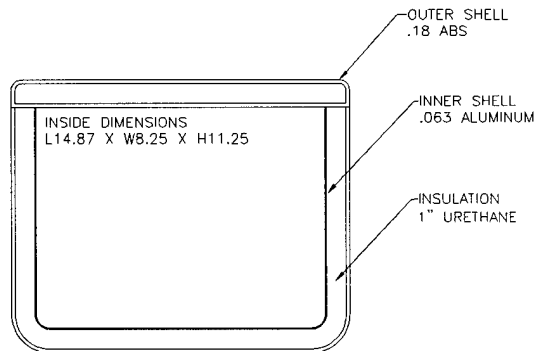

Fig. 3
Insulated Chamber Cross-section

Given:

- Material conductivity: C
- | | |
|-----------------------|------------|
| ABS | .36W/m-°C |
| Urethane foam (10psf) | .026W/m-°C |
| Aluminum alloy | 155W/m-°C |

- Thermal resistivity: $R=1/C$

ABS	$R_1= 2.8^{\circ}\text{C}\cdot\text{m}/\text{W}$
Urethane foam	$R_2=38.4^{\circ}\text{C}\cdot\text{m}/\text{W}$
Aluminum alloy	$R_3=6.5\text{e}\cdot 3^{\circ}\text{C}\cdot\text{m}/\text{W}$
- Environment:

Internal temperature T_2	-10°C
Ambient (external) T_1	30°C
Area	$A=.49\text{m}^2$

Heat pumping requirement:

Total resistance $R_t = (R_1(.18\text{in} \times .0254\text{m}/\text{in}) + R_2(1\text{in} \times .0254\text{m}/\text{in}) + R_3(.063\text{in} \times .0254\text{m}/\text{in}))/A$
 Then : $R_t \approx 2.04^{\circ}\text{C}/\text{W}$ @ $\Delta T = 40^{\circ}\text{C}$ the heat loss $Q = 19.6\text{W}$

To allow for heat loss through access ports and fasteners use a safety factor of two (2) then heat pumping capability required is approximately **40W**.

2. Evaluation and Characterization Testing

2.1. Evaluation of possible Cooling Means Required for Mild Hypothermia Device

Existing refrigeration techniques and blood heat exchangers were evaluated for use as the cooling means for cooling the blood in an extra-corporeal shunt circuit. The following methods were evaluated and the technical reports describing the methodology and evaluation are attached in the appendices.

- Vortex tube refrigeration (Appendix A)
- Stirling cycle refrigeration and variations (Appendix B,C)
 1. Stirling cycle
 2. Pulse tube
 3. Acoustic tube cooling
 4. Malone refrigeration
- Magneto-caloric refrigeration (Appendix D)
- Thermo-electric modules (Appendix H,M,N)
- Liquid or gas expansion (carbon dioxide) (Appendix F)
- Mechanical refrigeration (Appendix G)

2.2.Evaluation of Cooling Means Required for Maintaining a Large Volume of Sterile Fluid at -10°C

The following methods were evaluated for use as the cooling means in the profound hypothermia Device. The cooling requirement for this device is much less than that for the shunt-cooling requirement for the induction of mild hypothermia. 1.2.4, 1.3.5 above.

- Absorption cycle refrigeration (Appendix J,L,O)
- Mechanical refrigeration (Appendix G)
- Thermo-electric modules (Appendix H,M,N)

Key Research Accomplishments:

- Developed the preliminary requirements for mild hypothermia cooling device.
- Developed the preliminary requirements for profound hypothermia cooling device.
- Determined the heat load, flow requirements, and cooling means pumping capacity requirements through literature searches, collaboration with researchers, and computer modeling.
- Developed preliminary design requirements for both the mild and profound hypothermia devices
- Evaluated and performed laboratory tests for ten (10) cooling means considered for the induction of hypothermia.
- Researched the available power available in rescue and transport vehicles.
- Acquired materials constructed and performed and documented laboratory testing of engineering models of the selected cooling systems.
- Characterized the commercially available cooling and heat exchanger components through laboratory testing.
- Generated electrical designs for the circuitry required for the temperature control, pump control, etc for both mild and profound hypothermia inducing devices.
- Generated the cooling loop and fluid flow designs for both mild and profound hypothermia inducing devices.

Reportable Outcomes:

See the body of this report. There were no publications, patents or licenses, etc. applied for or issued in connection with this work.

Conclusions:

The conclusions that resulted from this work are:

- The development of devices that meet the requirements, as defined in the body of this report, for inducing both mild and profound hypothermia is feasible.

- Existing disposable blood heat exchangers are not sufficient to meet the requirements and a custom blood heat exchanger must be developed.
- Two cooling methodologies are acceptable for the cooling means for the mild hypothermia inducing device 1) CO₂ expansion and 2) direct exchanger cooling by means of mechanical vapor compression.
- Two cooling methodologies are acceptable for use as the cooling means for a profound hypothermia inducing device 1) absorption refrigeration and 2) mechanical vapor compression refrigeration.
- Additional prototype devices should be developed and constructed incorporating each of the technologies for evaluation by the Safar Center for Resuscitation Research.

Personnel

Personnel Participating and Receiving Pay From This Research Effort

Alsippi, Richard	Jr. Engineer
Cooper, Patrick	Mgr. Product Applications
Cupp, James	Research Engineer
Felton, Dave	Mgr. Test Engineering
Garland, Brian	Machine Shop Supervisor
Gill, Ralph	Mgr. Mechanical Engineering
Grata, Jeremy	Mgr. Research
Gresko, Brian	Mechanical Engineer
Griffith, Scott	Mgr. Product Development
Kozyro, Daniel	Mechanical Engineer
McMurry, Dave	President/Mechanical Engineer
Myers, Larry	Jr. Electronics Engineer
Nesmith, Shawn	Sr. Mechanical Engineer
Niziol, Stanley	Sr. Software Engineer
Noble, Peter	Sr. Mechanical Engineer
Novak, William	Sr. Mechanical Engineer
Park, Christina	Electronics Engineer
Pasumarthy, Krishna	Mgr. Software Engineering
Pitsakis, Mike	Mgr. Electronics Engineering
Powers, Tammy	Research Chemist
Rapach, Chuck	Sr. Electronics Engineer
Reighard, Dennis	Mgr. Manufacturing Operations
Rietscha, Scott	Production Technician
Saxman, Nancy	V.P. Business Development
Smith, Larry	Machinist
Stiles, Wayne	Mfg. Engineering Technician
Stipcak, Dave	Machinist
Thomas, Jeffrey	Sr. Optical Engineer
Zapach, Mike	CAD Operator
Zhuze, Vladimir	Sr. Software Engineer

References:

-
- ¹ Leonov Y, Sterz F, Safar P, et al: Mild cerebral hypothermia during and after cardiac arrest improves neurologic outcome in dogs. *J Cereb Blood Flow Metab* 1990;10: 57-70.
 - ² Sterz F, Safar P, Tisherman S, Radovsky A, Kuboyama K, Oku K: Mild hypothermic cardiopulmonary resuscitation improves outcome after cardiac arrest in dogs. *Crit Care. Med.* 1991;19:379-389
 - ³ Bernard SA, Jones BM, Horne MK. Clinical trial of induced hypothermia in comatose survivors of out-of-hospital cardiac arrest. *Ann Emerg Med* 1997;30:146-53.
 - ⁴ Zeiner A, Holzer M, Sterz F, et al. Mild resuscitative hypothermia to improve neurological outcome after cardiac arrest; clinical feasibility trial. *Stroke* 2000;3:86-94
 - ⁵ Bernard SA, Gray TW, Buist MD, et al. Treatment of comatose survivors of out-of-hospital cardiac arrest with induced hypothermia. *N Engl J Med* 2002;346:557-563
 - ⁶ Woods RJ, Pruecker S, Safar P, et al: Hypothermic aortic flush for preservation during exsanguinations cardiac arrest of 15 minutes in dogs. *J Trauma* 1999;47:1028-1036
 - ⁷ Behringer W, Prueckner S, Kentner R, et al: Rapid hypothermic aortic flush can achieve survival without brain damage after 30 minutes cardiac arrest in dogs. *Anesthesiology* 2000;93:1491-1499.
 - ⁸ Behringer W, Safar P, Kentner R, et al: Intact survival of 60, 90, 120 min cardiac arrest in dogs with 10°C preservation by cold aortic flush. Study II. *Crit Care Med* 2001; 28(Suppl.). A65 (Abstract).

BIOCONTROL TECHNOLOGY

APPENDICES

APPENDIX A

TECHNICAL REPORT

#TECHRP REV. D

**RECORD #
256**

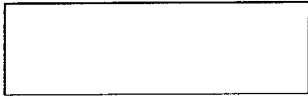

TITLE Vortex Tube Analysis for the Hypothermia Project		FILENAME 011029dk.doc	REVISION 00
PROJECT OR PROGRAM NAME Hypothermia Devices		PROGRAM ROOT NUMBER 78	
PROGRAM TASK DESCRIPTION Device Research		PROGRAM TASK NUMBER 00	
NAME Dan Kozyro		DEPARTMENT Engineering	DATE 10/29/01
TECHNICAL AREA			

SUBJECT AND KEY TECHNICAL WORDS
hypothermia, tube cooling

DOCUMENTATION TYPE

<input type="checkbox"/> Validation	<input type="checkbox"/> Error Budget	<input type="checkbox"/> Reliability	<input type="checkbox"/> Sensitivity
<input type="checkbox"/> Verification	<input type="checkbox"/> Product Support	<input type="checkbox"/> Risk Analysis	<input checked="" type="checkbox"/> Other

ASSOCIATED REPORTS

Abstract

This report will determine whether or not the cooling provided by a Vortex Tube configuration is sufficient for the Hypothermia device. The heat load that must be removed from the primary fluid is 1067 W. The intended design of the cooling system is for heat to be transferred from primary to secondary fluid through a heat exchanger. Running the Vortex Tube at maximum capacity would be impractical because of the air supply required to do so. In conclusion, the Vortex Tube cooling system is not capable of providing the cooling necessary for the Hypothermia unit.

Background

The Hypothermia Project is a research and development contract funded by the Department of the Army. The device will be used to cool blood from 38°C to 6°C. The device will have a means by which the operator may adjust the set point and provide a read out of the set point temperature, and the current temperature. The device is also intended to be small enough to be carried by an individual into a remote location that has no readily available source of electrical power.

Introduction

In order to cool the blood from 38°C to 6°C, 1067 W of cooling will be required. The cooling system will have to be light and portable, preferably less than 60 lbs. There are several cooling methods that are being considered:

1. Mechanical Refrigeration
2. Gas Expansion (CO₂)
3. Thermoelectric Cooler
4. Evaporation of liquids
5. Vortex Tube
6. Stored Ice Bath
7. Endothermic Chemical Reaction

The focus of this technical report will be the Vortex Tube cooling method.

The Vortex Tube evaluated in this case was the *EXAIR* brand. A Vortex Tube works by allowing compressed air at approximately 80-100 PSIG to be ejected tangentially through a generator into the vortex spin chamber. At up to 1,000,000 RPM, this air stream revolves toward the hot end where some escapes through the control valve. The remaining air, still spinning, is forced back through the center of this outer vortex. The inner stream gives off kinetic energy in the form of heat to the outer stream and exits the vortex tube as cold air. The outer stream exits the opposite end as hot air. The cold air is then used as a secondary fluid to remove heat from the blood.

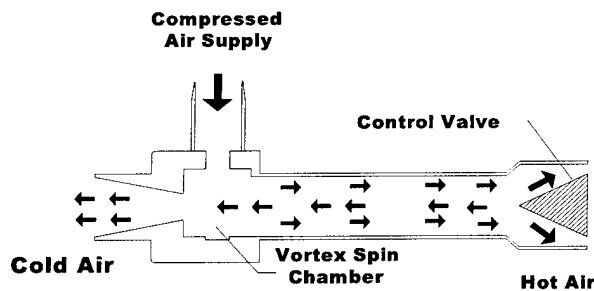

The key to this method is to have enough air supply to provide cooling for approximately 45 minutes. Maximum cooling occurs when the Vortex Tube is supplied with 150 cubic feet of air per minute. Once the air is cooled, it will be directed to the secondary side of a heat exchanger. Heat will be passed from the warm blood to the cool air through basic laws of heat transfer. The air will then be ejected to the atmosphere and will not be re-used.

Purpose

The purpose of this technical report is to determine whether or not a Vortex Tube will provide sufficient cooling to meet the specifications of the Hypothermia unit.

Description of Apparatus and Setup

If this Vortex Tube were used, the heat exchange system would consist of a heat exchanger that would allow for heat to flow from the warm blood at 38°C to the colder air at approximately -5°C. The Hypothermia design requirements specify that 45 minutes of cooling is required. The desired method of providing the air supply would be compressed air in a portable tank. The calculations for how much air would be required are listed below.

Cooling Capacity for the EXAIR Vortex Tube

Air Flow (SCFM)	Cooling Capacity @ 100PSIG (Btu/hr)	Cooling Capacity @ 100PSIG (W)	Required Air Capacity (SCF)
2	134	39.24525	90
4	275	80.540625	180
8	550	161.08125	360
10	650	190.36875	450
15	1000	292.875	675
25	1700	497.8875	1125
30	2000	585.75	1350
40	2800	820.05	1800
50	3400	995.775	2250
75	5100	1493.6625	3375
100	6800	1991.55	4500
150	10200	2987.325	6750

Note: For maximum cooling the cold fraction should be 80% with a temperature difference of 50°F below ambient.

The previous data was taken from the Vortex Tube manufacturers' specification sheet.

The thermal cooling power required for the Hypothermia unit to perform its function 1067 W. The cooling power provided by the EXAIR Vortex Tube at maximum capacity is 2987.3 W. With a margin of safety of approximately 2.8, this system of cooling appears viable, but it is not. The compressed air supply required to generate maximum cooling is 6750 cubic feet. This amount is well below what could be portable and taken along with the hypothermia unit as a power source for the Vortex Tube.

Summary of Data and Results

The results from the calculations obtained above represent best-case scenarios. The amount of air required to operate the Vortex Tube is unreasonable.

Conclusions

The Vortex Tube is not a suitable cooling method for the Hypothermia Project. The hardware and system requirements that would be needed to run the Hypothermia unit are too great.

Suggestions for Further Work

Continue to search for other methods that would provide the necessary cooling to meet the specifications of the Hypothermia unit.

TITLE Evaluation of the Stirling Cycle as a Cooling Means		FILENAME TR_Hypo020912RG.doc	REVISION
PROJECT OR PROGRAM NAME Hypothermia Device Research		PROGRAM ROOT NUMBER 78	
PROGRAM TASK DESCRIPTION Research of Cooling Methods		PROGRAM TASK NUMBER 00	
NAME Ralph Gill		DEPARTMENT Mechanical Engineering	DATE 9/12/02
TECHNICAL AREA Refrigeration Concepts			
SUBJECT AND KEY TECHNICAL WORDS Refrigeration, Stirling, Malone, Hypothermia			
DOCUMENTATION TYPE			
<input type="checkbox"/> Validation	<input type="checkbox"/> Error Budget	<input type="checkbox"/> Reliability	<input type="checkbox"/> Sensitivity
<input type="checkbox"/> Verification	<input type="checkbox"/> Product Support	<input type="checkbox"/> Risk Analysis	<input checked="" type="checkbox"/> Other
ASSOCIATED REPORTS			

Abstract

This report presents the literature and technical research to evaluate the Stirling Cycle and the Malone Cycle refrigeration concepts for use as the cooling means in Hypothermia devices. As part of the Hypothermia research program several alternative methods for cooling the heat exchanger and ultimately the blood circuit are being investigated. The investigation of alternative methods of refrigeration is based on the need to minimize the size and power consumption of the Hypothermia devices for use in mobile and/or remote locations. The Stirling Cycle and the Malone Cycle variation refrigeration concept is described along with the status of the development of a practical refrigeration unit that has the pumping capability to meet the refrigeration requirements of the hypothermia devices. The conclusion based on the documentation and references presented here, is that the development has not progressed at this time to a level that would be a viable solution to the cooling requirement for a Hypothermia device. However versions of the concept are under development for refrigeration use and should be re-visited to monitor future development.

Background

Both the Stirling Cycle and Malone Cycle (a variation of the Stirling Cycle), use no CFC's, HCFC's, or any other potentially hazardous chemical. Stirling Cycle refrigerators can be operated over a wide range of temperatures, and are therefore applicable to numerous space and commercial refrigeration requirements, medical devices, and laboratory freezers.

Introduction

The development of a device for enabling the induction of mild to moderate Hypothermia in a remote setting requires a compact, efficient, and mobile method of generating sufficient refrigeration capacity for quickly cooling the blood in an extra-corporeal circuit. Present mechanical refrigeration units are too bulky and heavy to satisfy these requirements, thus alternative methodology will be investigated. This literature search will evaluate one possible technique for accomplishing this end result.

Purpose

The purpose of this research is to evaluate the present status of the development of pulse tube and thermo-acoustic refrigeration concepts and the development of enabling hardware. An on going desire to locate and incorporate a novel/or alternative method of pumping heat from a heat transfer medium, which is ultimately employed to cool blood in an extra-corporeal circuit, prompted this research of existing data.

Description of Apparatus and Setup

No apparatus is required for this literature only search.

Summary of Data and Results

Description of the Stirling Cycle and the Malone variation

The Stirling Cycle:

Figure 1 depicts schematically a typical Stirling cooler cross section.

The opposed pistons in the compressor module and the displacer in the cold finger are the only moving parts in the stirling cycle cooler.

The displacer contains a regenerative heat exchanger or "regenerator". The pistons are driven by the linear motors, producing gas pressure fluctuations that act on the spring-loaded displacer.

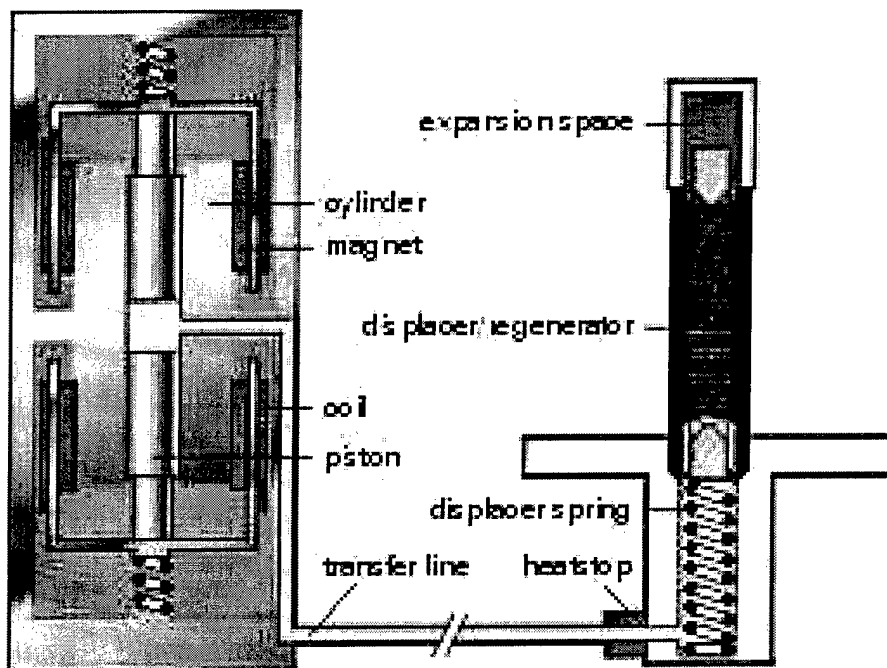

Fig. 1
Stirling cooler cross section

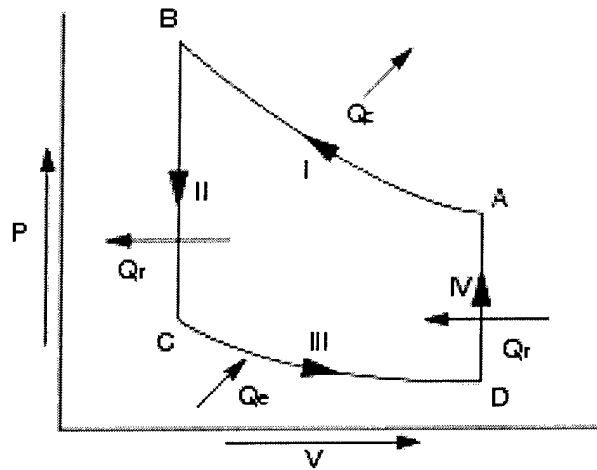

Fig 4
The Stirling cooling Cycle P-V curve

Phase I:

Virtually all the gas is in the compression space at ambient temperature and the displacer is in the tip of the cold finger. In this phase the pistons are driven inwards, compressing the gas. This process is nearly isothermal, the heat output Q_c being dissipated via heat sinks around the compressor and the base of the cold finger.

Phase II:

The pistons have reached the end of the compression stroke, the gas in the compression space is at ambient temperature and the displacer has not yet moved. This is the situation at the start of Phase II. Throughout this phase the pistons remain stationary and hence the total volume of gas remains constant. The displacer moves downwards as its spring compresses and gas flows through the regenerator, giving up heat Q_r in the process. This heat is stored in the regenerator until later in the cycle.

Phase III:

The pistons are driven outwards and the gas expands. This expansion process, too, is nearly isothermal, the heat input Q_e being drawn from the surroundings of the expansion space. As a result refrigeration occurs at the tip of the cold finger.

Phase IV:

Throughout this phase the pistons remain stationary. The displacer, however, moves upwards because of the lower gas pressure in the expansion space. Gas from the expansion space then flows back through the regenerator, taking up the stored heat Q_r in the process and re-entering the compression space at ambient temperature.

Refrigeration occurs around the tip of the cold finger, which contains an "expansion space". The displacer moves gas into and out of this space from a "compression space" consisting of the space between the pistons, the space in the split tube and the space below the warmer end of the displacer.

If we examine the P-V curve it is obvious the net work done is the difference between the work done in the AB leg and the CD leg. The other two constant volume legs (BC and DA) contribute nothing since $dV=0$.

The Malone Cycle:

Description:

Malone refrigeration is a variation on the Stirling cycle with the exception that the transport fluid is a liquid near its critical point without evaporation, rather than a vapor or gas. At this time only primitive prototypes have been built. The research is intended to develop an efficient, compact design device with a safe working fluid.

Conclusions

The Stirling cycle is a proven technology having been in use since the 1800's. However the heat needs to be moved through a secondary circuit to make use of it in our application. The variations are not yet mature enough to consider for the immediate future.

The Stirling cycle refrigerator might be a feasible technology for use in the profound hypothermia device if a suitable secondary circuit is designed. This circuit would probably consist of a thermo-siphon using a working fluid such as CO₂ for the heat transport. We should further investigate the possibilities for future incorporation into a device.

Suggestions for Further Work

Presently work is being done by others that indicate it may be possible to use the Stirling Cycle as a room temperature refrigerator. The progress should be monitored to evaluate the future progress in its development.

APPENDIX C

BIOCONTROL
TECHNOLOGY INC.

TECHNICAL REPORT

#TECHRP REV. D

RECORD #
268

TITLE Analysis of Pulse-tube and Thermo-acoustic Refrigeration		FILENAME TR_Hypo020520RG.doc	REVISION 00
PROJECT OR PROGRAM NAME Hypothermia Research		PROGRAM ROOT NUMBER 78	
PROGRAM TASK DESCRIPTION Research of Cooling Methods		PROGRAM TASK NUMBER 00	
NAME Ralph Gill		DEPARTMENT Engineering	DATE 5/20/2002
TECHNICAL AREA Refrigeration concepts			
SUBJECT AND KEY TECHNICAL WORDS Refrigeration, Pulse, Tube, Hypothermia, Blood, Heat, Exchanger, Research			
DOCUMENTATION TYPE			
<input type="checkbox"/> Validation	<input type="checkbox"/> Error Budget	<input type="checkbox"/> Reliability	<input type="checkbox"/> Sensitivity
<input type="checkbox"/> Verification	<input type="checkbox"/> Product Support	<input type="checkbox"/> Risk Analysis	<input checked="" type="checkbox"/> Other
ASSOCIATED REPORTS 011029dk, 020513rg			

Abstract

This report presents the literature and technical research to evaluate the pulse tube and thermo-acoustic refrigeration concept for use in the mild to moderate Hypothermia devices. As part of the Hypothermia research program several alternative methods for cooling the heat exchanger and ultimately the blood circuit are being investigated. The investigation of alternative methods of refrigeration is based on the need to minimize the size and power consumption of the Hypothermia devices for use in mobile and/or remote locations. The pulse tube refrigeration concept is described along with the status of the development of a practical refrigeration unit that has the pumping capability to meet the refrigeration requirements of the hypothermia devices. The conclusion based on the documentation and references presented here, is that the development has not progressed at this time to a level that would be a viable solution to the cooling requirement for a Hypothermia device.

Background

Both the pulse-tube and thermoacoustic devices are variations of the Stirling Cycle and like the Stirling Cycle, use no CFC's, HCFC's, or any other potentially hazardous chemical. It uses only helium as the working fluid and is therefore nontoxic to humans and harmless to the environment. Pulse-tube Refrigerators can be operated over a wide range of temperatures, and are therefore applicable to numerous space and commercial refrigeration requirements, medical devices, laboratory freezers, and freeze dryers, as well as detector and electronics cooling.

Introduction

The development of a device for enabling the induction of mild to moderate Hypothermia in a remote setting requires a compact, efficient, and mobile method of generating sufficient refrigeration capacity for quickly cooling the blood in an extracorporeal circuit. Present mechanical refrigeration units are too bulky and heavy to satisfy these requirements, thus alternative methodology will be investigated. This literature search will evaluate one possible technique for accomplishing this end result.

Purpose

The purpose of this research is to evaluate the present status of the development of pulse tube and thermo-acoustic refrigeration concepts and the development of enabling hardware. An on going desire to locate and incorporate a novel/or alternative method of pumping heat from a heat transfer medium, which is ultimately employed to cool blood in an extracorporeal circuit, prompted this research of existing data.

Description of Apparatus and Setup

No apparatus is required for this literature only search.

Summary of Data and Results

History of the concept:

The Pulse-tube Refrigeration Cycle is a relative newcomer compared to other refrigeration cycles. In the early 1960s, Professor Gifford of Syracuse University and his graduate student, R. Longworth, noticed the effect during the operation of an air compressor. By connecting a capped plumbing line to a compressor through a regenerator, cooling was achieved at one end and heating at the other, thus the birth of the Basic Pulse-tube Refrigerator. Figure 1 is a schematic drawing of the Basic Pulse-tube Refrigerator. The original one-stage cooler was reported to have achieved 150 K while a two-stage device achieved 120 K. The results of early work with the pulse tubes did not achieve satisfactory efficiency and the pulse tubes were abandoned as practical coolers.

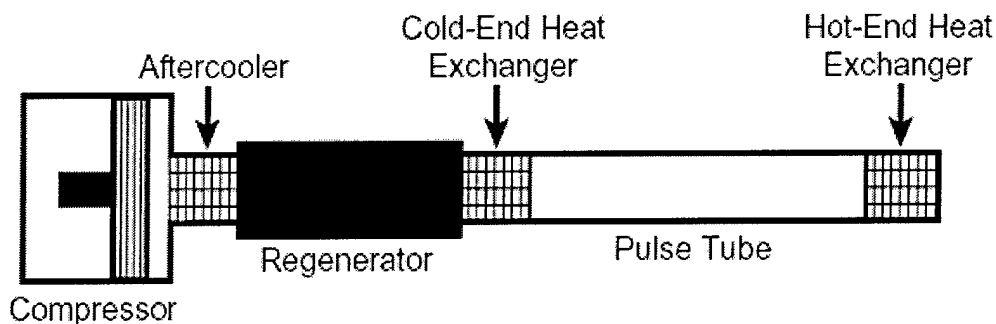

Figure 1. Basic Pulse-tube Refrigerator

The primary advantages of pulse tube coolers over the standard Stirling coolers are that they have no moving parts in the low temperature region and they are a closed oscillating system. Meaning there is no friction, no wear and essentially no vibration. Therefore the low temperature regions have an unlimited lifetime. Referring to Fig.1, the **compressor** at the left side generates an oscillating pressure and thus creating an oscillating flow in the rest of the system. The **after cooler** is a heat exchanger that removes the heat of compression. The **regenerator** is a type of heat exchanger that does not remove heat from the system; instead it removes heat from the gas in one part of the cycle and returns it to the gas on the return cycle. The **pulse tube** creates a suitable phase shift between the pressure and gas flow thereby transporting heat from the cold to the hot region. Later around 1982 it was shown that by adding an orifice and a reservoir at the hot end of the pulse tube the phase shift between the pressure and mass flow could be increased. This increased the efficiency of the cooler and led to what is known as the Orifice Pulse Tube, Fig.2

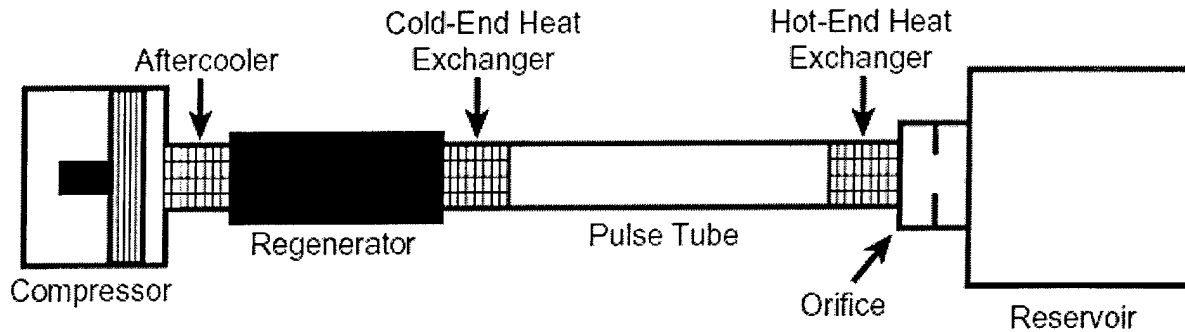

Figure 2. Orifice Pulse Tube Refrigerator

The next major innovation was the double inlet pulse tube. This concept was then refined into what is now the multiple bypass tube, Fig.3.

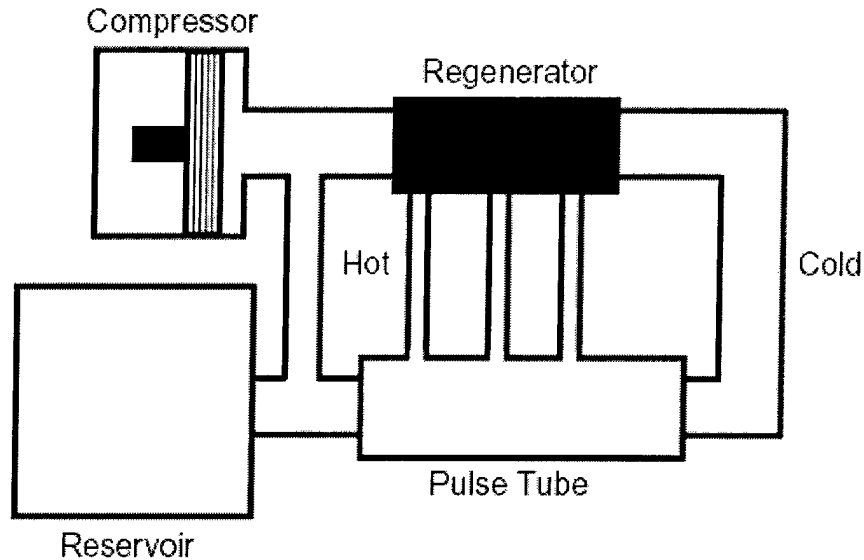

Figure 3. Multiple Bypass Pulse Tube Refrigerator

Thermoacoustic coolers:

Thermoacoustic devices work in a similar manner to the pulse tube devices. In the thermoacoustic system the compressor is replaced with an acoustic driver similar to a speaker. This driver generates the pressure oscillations (acoustic wave) through the movement of a diaphragm. This system must operate at the column resonance to be effective and is much less efficient than piston driven pulse tube.

References:

1. Kittel, Peter, "A Short History of Pulse Tube Refrigerators," *Cold Fact*, Vol. II, No. 1, (Winter 1995). A Newsletter of the Cryogenic Society of America, Oak Park, Illinois.
2. Matsubara, Y. and Gao, J.L., "Experimental Investigations of a 4 K Pulse Tube Refrigerator," *Cryogenics*, Vol. 34, 1994.
3. Zhu, S., Wu, P., Zhen, Z., and Zhou, Y., "A Single-Stage Double Inlet Pulse Tube Refrigerator Capable of Reaching 42 K," *Proceedings of ICEC 13, Cryogenics*, Vol. 30, 1990, p. 262 ff.
4. Zhou, Y. and Han, Y.J., "Pulse Tube Refrigeration Research," *Proceedings of the 7th International Cryocooler Conference*, 1993.
5. Kittel, Peter, "Enthalpy Flow Transition Losses in Regenerative Cryocoolers," *Proceedings of the 7th International Cryocooler Conference*, 1993.
6. Lee, J.M., Kittel, P., Timmerhaus, K.D., and Radebaugh, R., "Steady Secondary Momentum and Enthalpy Streaming in the Pulse Tube Refrigerator," *Proceedings of the 8th International Cryocooler Conference*, 1994.
7. Kittel, Peter, "Ideal Orifice Pulse Tube Refrigerator Performance," *Cryogenics*, Vol. 32, 1992, p. 843.
8. Walker, Graham, "Cryocoolers," Parts 1 and 2, Plenum Press.
9. Radebaugh, Ray, "A Review of Pulse Tube Refrigeration," *Advances in Cryogenic Engineering*, Vol. 35, 1990.
10. Rawlings, R.M. and Miskimins, S.M., "Flexure Springs Applied to Low Cost Linear Drive Cryocoolers," *Cryocoolers 11*, Kluwer Academic/Plenum Publishers, NY, 2001.
11. Glaser, R.J., Ross, R.G., Jr. and Johnson, D.L., "STRV Cryocooler Tip Motion Suppression", *Cryocoolers 8*, Plenum Publishing Corp., New York, 1995, pp. 455-463.
12. Ross, R.G., Jr., "JPL Cryocooler Development and Test Program: A 10-year Overview," *Proceedings of the 1999 IEEE Aerospace Conference*, Snowmass, Colorado, Cat. No. 99TH8403C, ISBN 0-7803-5427-3, 1999, p. 5.
13. Johnson D.L., "Thermal Performance of the Texas Instruments 1-W Linear Drive Cryocooler,"

Cryocoolers 10, Kluwer Academic/Plenum Publishers, NY, 1999, pp. 95-104.

14. Kotsubo, V., Olson, J.R., and Nast, T.C., "Development of a 2W at 60K Pulse Tube Cryocooler for Spaceborne Operation," *Cryocoolers 10, Kluwer Academic/Plenum Publishers, NY, 1999, pp. 157-170.*

15. Kotsubo, V., Olson, J.R., Champagne, P., Williams, B., Clappier, B. and Nast, T.C., "Development of Pulse Tube Cryocoolers for HTS Satellite Communications," *Cryocoolers 10, Kluwer Academic/Plenum Publishing Corp., NY, 1999, pp. 171-179.*

Conclusions

The commercially available pulse tube coolers operate in the cryogenic range down to 35K and is therefore a lower heat pumping capacity refrigerator than that required to cool a blood cooling device. However work ongoing for the Marshall Space Flight Center has resulted in the demonstration of a pulse tube refrigerator operating in the range (temperature and capacity) required for food freezers.

Suggestions for Further Work

The recent advances demonstrating capabilities within the desired range for a blood cooling device, warrant continuing the monitoring of these developments.

TITLE Analysis of Magnetic Refrigeration		FILENAME TR_Hypo 20513RG.doc	REVISION 00
PROJECT OR PROGRAM NAME Hypothermia Research		PROGRAM ROOT NUMBER 78	
PROGRAM TASK DESCRIPTION Research of Cooling Methods		PROGRAM TASK NUMBER 00	
NAME Ralph Gill		DEPARTMENT Engineering	DATE 5/13/02
TECHNICAL AREA Refrigeration concepts			
SUBJECT AND KEY TECHNICAL WORDS Refrigeration, Magnetic, Hypothermia, Blood, Heat, Exchanger, Research			
DOCUMENTATION TYPE			
<input type="checkbox"/> Validation	<input type="checkbox"/> Error Budget	<input type="checkbox"/> Reliability	<input type="checkbox"/> Sensitivity
<input type="checkbox"/> Verification	<input type="checkbox"/> Product Support	<input type="checkbox"/> Risk Analysis	<input checked="" type="checkbox"/> Other
ASSOCIATED REPORTS 011029dk			

Abstract

This report presents the literature and technical research to evaluate the Magnetic Refrigeration concept for use in the mild to moderate Hypothermia devices. As part of the Hypothermia research program several alternative methods for cooling the heat exchanger and ultimately the blood circuit are being investigated. The investigation of alternative methods of refrigeration is based on the need to minimize the size and power consumption of the Hypothermia devices for use in mobile and/or remote locations. The magnetic refrigeration concept is described along with the status of the development of a practical refrigeration unit. The conclusion based on the documentation and references presented here, is that the development has not progressed at this time to a level that would be a viable solution to the cooling requirement for a Hypothermia device.

Background

In a manner analogous to the commonly used gas cycle of compression and expansion to generate refrigeration, cycles of magnetization and demagnetization are used to achieve the same results. Some materials rise temperature when they are acted upon by a magnetic field and cool when demagnetized, this is referred to as the "magnetocaloric effect". This property can be exploited to produce refrigeration.

Introduction

The development of a device for enabling the induction of mild to moderate Hypothermia in a remote setting requires a compact, efficient, and mobile method of generating sufficient refrigeration capacity for quickly cooling the blood in an extracorporeal circuit. This literature search will evaluate one possible technique for accomplishing this end result.

Purpose

The purpose of this research is to evaluate the present status of the development of magnetic refrigeration concepts and the development of enabling hardware. An on going desire to locate and incorporate a novel/or alternative method of pumping heat from a heat transfer medium, which is ultimately employed to cool blood in an extracorporeal circuit, prompted this research of existing data.

Description of Apparatus and Setup

No apparatus is required for this only literature search.

Summary of Data and Results

Description of Magnetocaloric Effect:

Active refrigeration is achieved by cycling the magnetic field either through modulating the magnetic field or by passing the material into and out of the field. The heat generated and absorbed by the material must then undergo a cyclic heat transfer process to generate usable refrigeration. This process exhibits a high thermodynamic efficiency and volumetric efficiency in part because the working material is a solid and the effect being reversible, and in part because only the net work of refrigeration is expended. A coefficient of performance of approximately 16 has been achieved albeit through the use of super-conducting magnets. Though not new technology, (5 decades +), it has been used primarily in the low cryogenic range near absolute zero. Presently most the commercial refrigeration work using this concept has been in the cryogenic region, e.g. liquefaction of gases. Lab devices for experimental use are commercially available with a working space temperature below 100mK.

Utilizing the magnetocaloric effect for cooling at room temperature, for refrigeration and air conditioning, requires research into magnetic materials that exhibit the needed properties at room temperature and new permanent magnets to generate higher fields. Research into new materials and material production is presently under way and an experimental room temperature refrigerator has been demonstrated.

References:

2001, *Magnetic refrigerator successfully tested.* Ames Laboratory news release, Dec. 7.

2001. *Astronautics Corporation of America demonstrated the world's first successful room temperature, permanent magnet, magnetic refrigerator at its Technology Center in Madison, Wisconsin.* Astronautics Corporation of America press release. Oct. 23.

1998, *Cars May be first to Benefit from Magnetic Refrigeration.* Iowa State University news release. Oct. 12.

Conclusions

The development of the magnetic refrigeration concept has not progressed to the stage that it is a viable alternative solution for room temperature refrigeration. However advances are being rapidly made that may make it viable in the near future.

Suggestions for Further Work

It is suggested that the evolution of hardware development in the area of magnetic refrigeration be monitored for feasibility of the inclusion of this concept at a later date. Much work is presently underway and may exhibit some major break through in the future that would make it a viable alternative cooling method.

APPENDIX E

TECHNICAL REPORT

#TECHRP REV. D

RECORD #

282



TITLE Liquid Carbondioxide Evaluation Tests		FILENAME TR_Hypo020822RG.doc	REVISION 00
PROJECT OR PROGRAM NAME Hypothermia Research		PROGRAM ROOT NUMBER 78	
PROGRAM TASK DESCRIPTION Research of Cooling Methods		PROGRAM TASK NUMBER 00	
NAME Ralph Gill		DEPARTMENT Mechanical Engineering	DATE 8/22/2002
TECHNICAL AREA Refrigeration Concepts			
SUBJECT AND KEY TECHNICAL WORDS Refrigeration,carbondioxide,cooling,blood,hypothermia			
DOCUMENTATION TYPE			
<input type="checkbox"/> Validation	<input type="checkbox"/> Error Budget	<input type="checkbox"/> Reliability	<input type="checkbox"/> Sensitivity
<input type="checkbox"/> Verification	<input type="checkbox"/> Product Support	<input type="checkbox"/> Risk Analysis	<input checked="" type="checkbox"/> Other
ASSOCIATED REPORTS TR_Hypo 020805 WN, TR_Hypo 020920 CR			

Abstract

The concept of cooling by means of the evaporation and expansion of liquid carbon dioxide was evaluated through laboratory testing. This cooling method is being considered for the cooling means in the hypothermia devices. A heat exchanger was constructed using a disposable exchanger concept; injecting liquid carbon dioxide through precision orifices into the heat exchanger base cooled the exchanger. A fluid (water) at approximately 37 degrees centigrade was pumped through the disposable section. The exchanger temperature, ambient temperature and fluid temperature were recorded throughout the testing. This data was used to evaluate the effectiveness of the cooling concept and the exchanger characteristics. According to the tests that were performed, desired performance is possible. However, a more suitable heat exchanger and a refined liquid distribution method are needed.

Background

Liquid carbon dioxide is used extensively as a means for flash freezing of foods, rapid cooling of environmental chambers and the production of dry ice. The concept is a logical candidate for inclusion as a candidate for the cooling means required for the hypothermia devices.

Introduction

The development of a device for enabling the induction of mild to moderate Hypothermia in a remote setting requires a compact, efficient, and mobile method of generating sufficient refrigeration capacity for quickly cooling the blood in an extra-corporeal circuit. Present mechanical refrigeration units are too bulky and heavy to satisfy these requirements, thus alternative methodology will be investigated. This testing is intended to evaluate the concept of an expendable refrigerant (carbon dioxide) as a solution.

Purpose

The purpose of the tests described here is the evaluation of the cooling methodology, the evaluation of the heat exchanger concept and verification of the previously performed literature and mathematical calculations.

Description of Apparatus and Setup

This process makes use of the Joules-Thompson effect. If a liquid is expanded through a throttling valve, in certain circumstances, to a lower density/pressure at constant enthalpy then the gas cools due to the change in energy state. The change in temperature is dependent upon the Joules-Thompson coefficient. For an ideal gas there are no intermolecular forces and the Joule-Thomson coefficient is zero thus there is no temperature change. There are conditions where the balance of forces is such that the Joule-Thomson coefficient is negative, so you get heating upon an expansion at constant enthalpy.

A major example of this is when the expansion of a liquid, with a positive Joules-Thompson coefficient, causes it to vaporize. Since vapor is a much higher energy state than the liquid, at the same temperature, the temperature is decreased by such an expansion so that the enthalpy remains constant. This expansion is the key step in most refrigeration cycles. Gas expansion would require high volumes and very high pressure on the input to the throttle valve. The fluid chosen for this concept is liquid CO₂. It was chosen because of several properties that it possesses; a) the critical temperature, b) the boiling temperature, c) Joules-Thompson coefficient, d) environmentally friendly, e) availability, and f) heat capacity.

The testing was performed using a commercially available, disposable heat exchanger. A list of instruments used in this experiment is listed below.

CO₂ Test Equipment List

Cassette or bag or heat exchanger = Gaymar Industries Hi Flow Disposable Warmer. Cassettes part no. D25330CE

CO₂ Valve = ASCO Model 8264G9 12VDC

Temperature controller = Omega CN132 12VDC

Recorder = Yokogawa Model MV112

Roller pump = Cole-Parmer Masterflex 77200-62

Needle thermocouples = Omega Hypodermic Needle Probe type HYP2

Other thermocouples = Type K

Power supply for solenoid = Hewlett Packard Model 6214A

Flow meter = Cole-Parmer 100-1500 ml/min

CO₂ Properties

- Triple point **-56.2°C @ 5.28 kg/cm²A = -69.9°F @ 75.1 psia**
- Critical temperature **31°C = 87.8°F**

- Critical pressure **74.24 kg/cm2G = 1056psig**
- Latent heat of vaporization **13.94 kcal/kg = 25 Btu/lb (-17.8°C)**
- Vapor pressure **@80°F -- 969 psia**
@50°F---652 psia
- Latent heat of liquid flashed to snow @ 1atm= 113btu/lb (liquid)

@68°F and 14.7 psia (1atm @20°C)

- Mol wt **44.0**
- Sp. gr (air=1) **1.53**
- Density **.115 #/cu ft**
- Sp vol **8.72 cu ft/lb**
- Sp heat , cp **.199 Btu/lb°F (.358 BTU/lb °C)**
- cp/cv=k **1.30**
- a=intermolecular force constant; for CO2, $a=366 \times 10^3 \text{ n-m}^4/(\text{kgm-mole-deg(K)})^2$
- boiling point @1 atm= **-78.5°C(-109.3°F)**
- R=universal gas constant=**8.3139 X 10³ joules/kgm-mole-deg(K)**
- Total heat absorbed from -78°C to -15°C: **Q=113 + (.358 x 63°C)=136btu/lb**

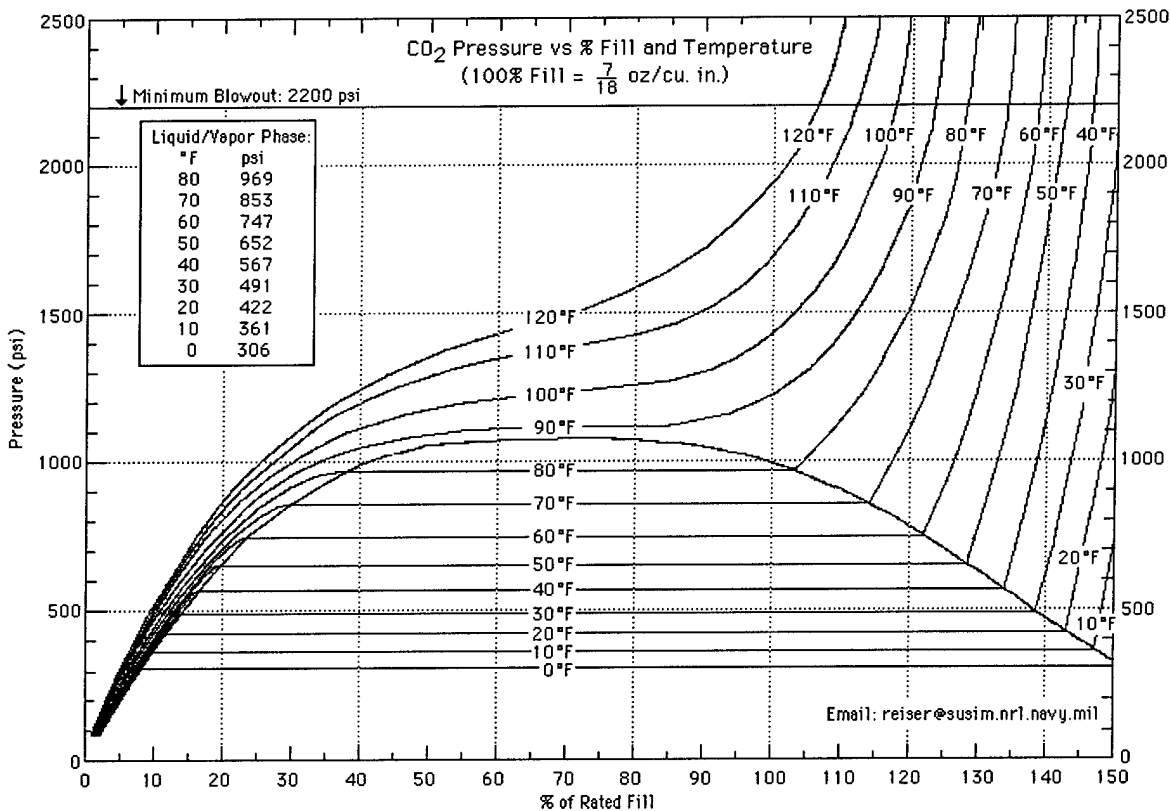

Fig. 1
LCO2 cylinder pressure vs. Temperature

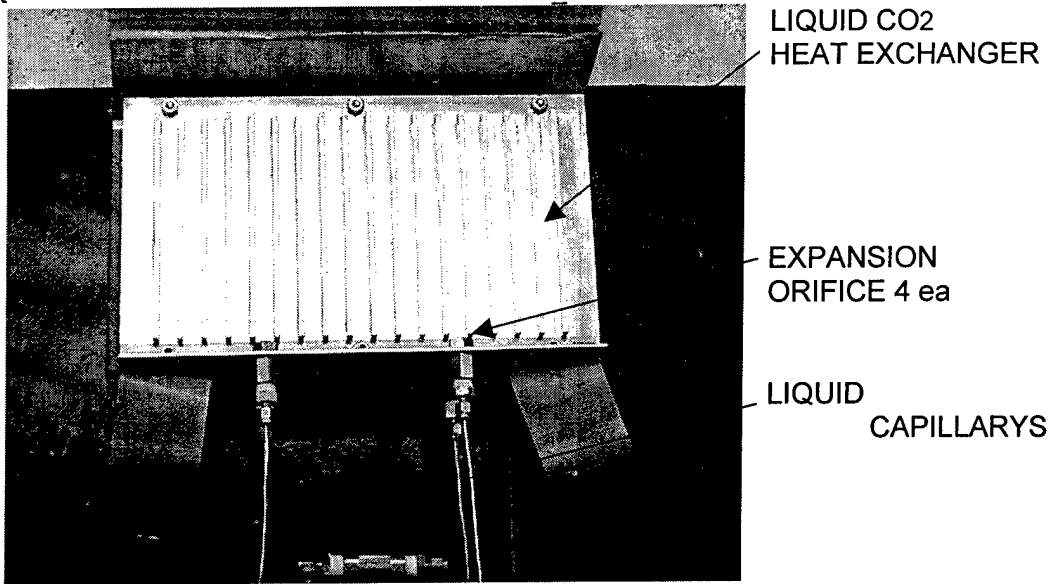

Fig. 2
CO2 Characterization Test

CO2 test 1

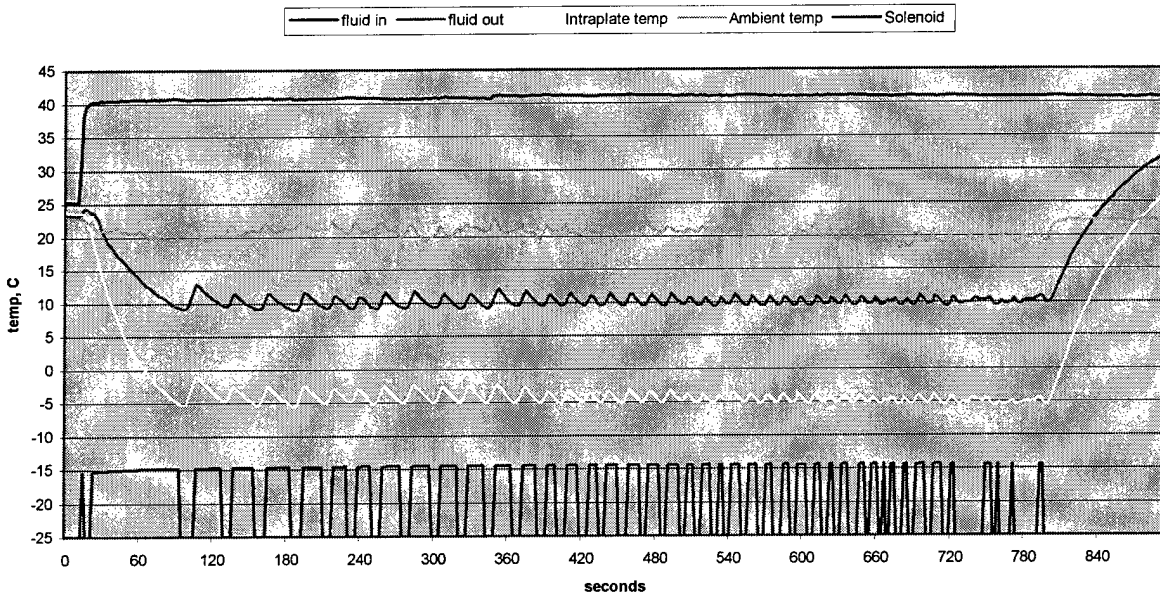

Fig. 3
Fluid Temperature vs. Time

The above data was taken without the controller installed and with the intra-plate thermocouple inserted between the two plates near the bag cavity.

Results for the second test series are depicted below.

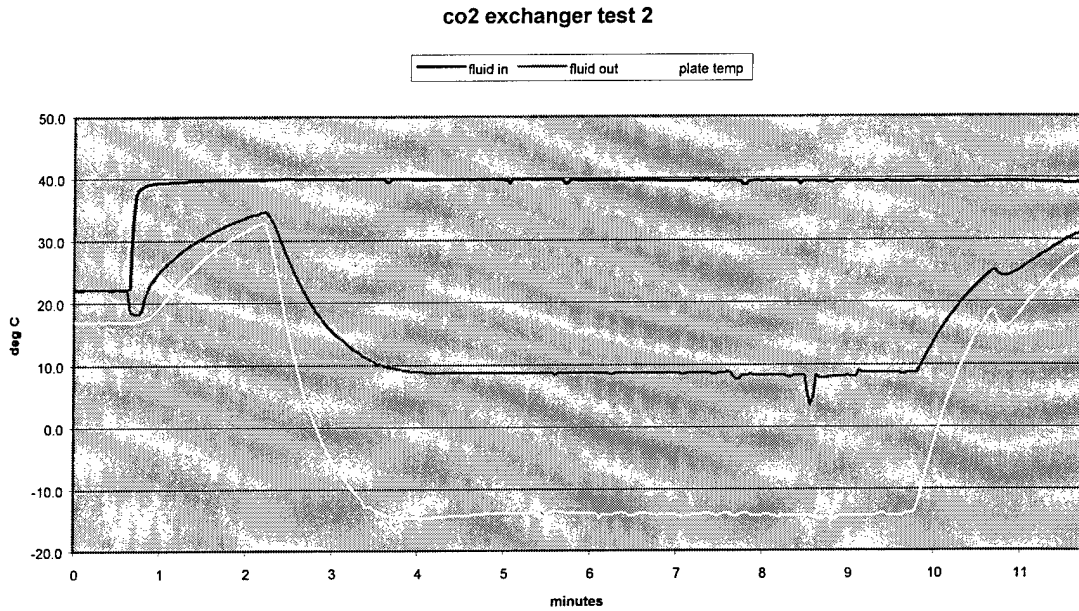

Fig. 4
Test 2 with PID controller installed

A second test was performed with a PID controller installed and used the exchanger plate temperature as the feedback for the control loop. The offset between the plate temperature and the fluid out temperature is indicative of an inefficient heat exchanger design.

During this test run the consumption rate of the liquid co2 was monitored and the consumption rate was approximately .9lb/min. This high consumption rate is also indicative of an inefficient heat exchanger.

A third configuration of the heat exchanger setup was tested using two heat exchangers in series. This setup required reconfiguring the liquid expansion orifices in order to get fluid coverage over a larger area. The test setup and results are shown below.

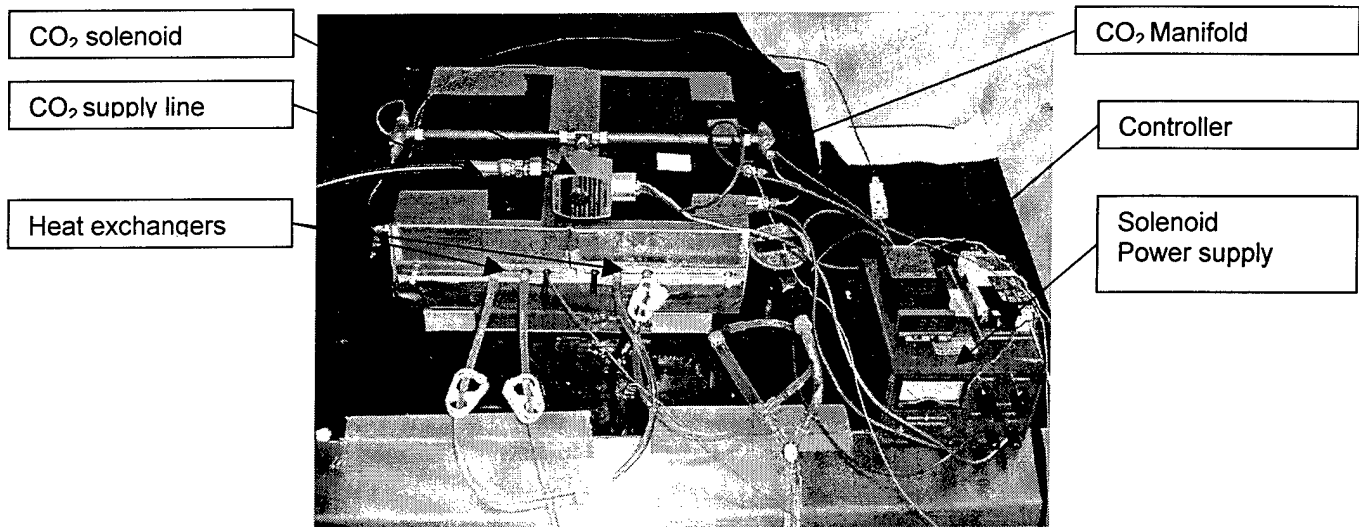

Fig. 5
Two stage exchanger test setup

CO2 Two Stage Cooling

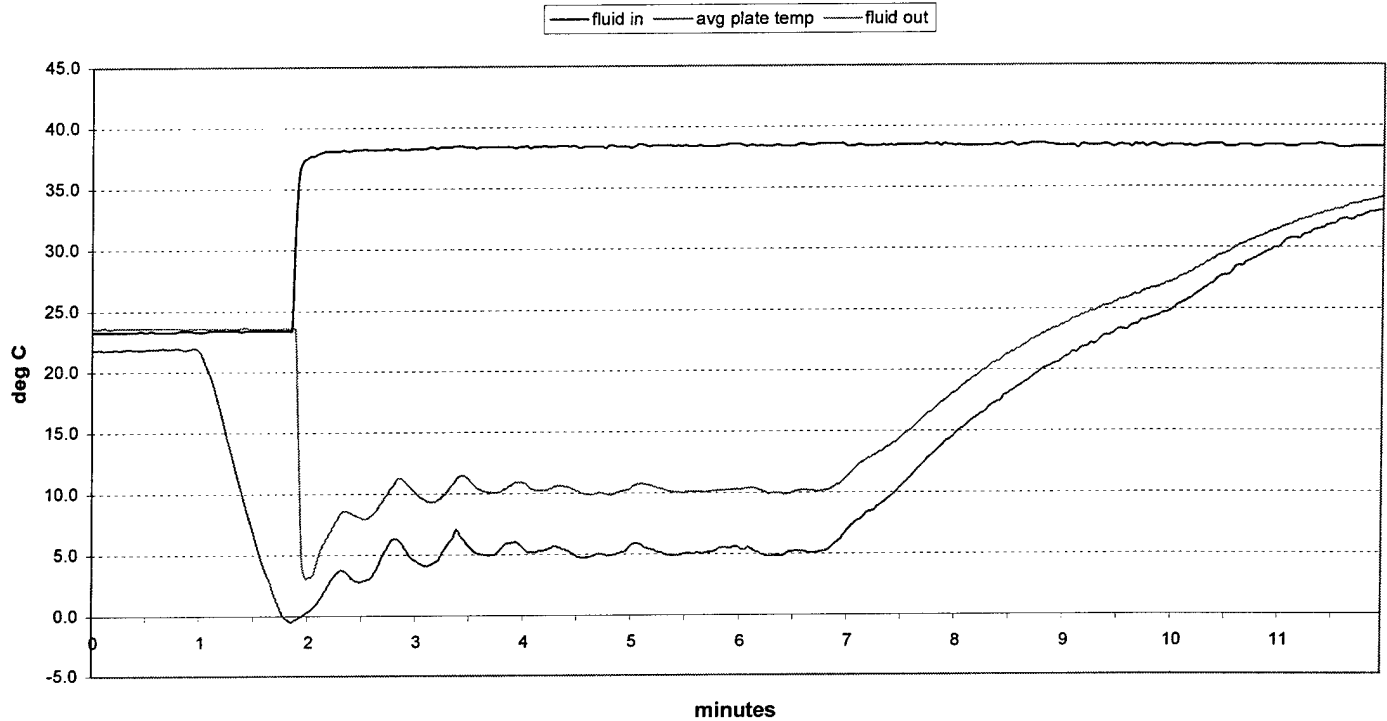

Fig. 6
Two stage test results

This two-stage setup used two disposable cassettes in series and a fluid flow rate of 500ml/min. The controller controlled the temperature based on feedback from the second stage plate. The temperature controller was auto-tuned for a single stage operation and was not optimized for this two-stage set up, thus the instability in holding the set point. This reconfigured test improved the consumption rate to .65lb/min and as can be seen on the chart (Fig. 3) the offset between the plate temperature and the fluid temperature is dramatically improved.

Conclusions

The tests that were performed show that the performance desired is possible with this concept. However, the commercially available heat exchangers are not acceptable for this use and the heat exchanger will be custom designed in the next phase of development.

The liquid distribution method requires refinement to improve the efficiency and decrease the consumption of the expendable refrigerant and will also be addressed in the design phase.

Suggestions for Further Work

No further tests will be performed that uses the commercial devices; these tests verify the feasibility of using this concept as the cooling means for the hypothermia devices.

TITLE Analysis of Liquid Carbon Dioxide Phase Change Refrigeration		FILENAME TR_Hypo020205RG.doc	REVISION
PROJECT OR PROGRAM NAME Hypothermia Research		PROGRAM ROOT NUMBER 78	
PROGRAM TASK DESCRIPTION Research of Cooling Methods		PROGRAM TASK NUMBER 00	
NAME Ralph Gill		DEPARTMENT Engineering	DATE 2/5/02
TECHNICAL AREA Refrigeration Concepts			
SUBJECT AND KEY TECHNICAL WORDS Carbon Dioxide, Hypothermia, Cooling, Refrigeration, Phase Change, Blood, Heat Exchanger			
DOCUMENTATION TYPE			
<input type="checkbox"/> Validation	<input type="checkbox"/> Error Budget	<input type="checkbox"/> Reliability	<input type="checkbox"/> Sensitivity
<input type="checkbox"/> Verification	<input type="checkbox"/> Product Support	<input type="checkbox"/> Risk Analysis	<input checked="" type="checkbox"/> Other
ASSOCIATED REPORTS 011029dk, 020513rg, 020520rg.doc, 020528rg.doc			

Abstract

This report presents the literature and technical research to evaluate the carbon dioxide phase change refrigeration concept for use in the mild to moderate Hypothermia devices. As part of the Hypothermia research program several alternative methods for cooling the heat exchanger and ultimately the blood circuit are being investigated. The investigation of alternative methods of refrigeration is based on the need to minimize the size and power consumption of the Hypothermia devices for use in mobile and/or remote locations. The phase change refrigeration concept is described along with the calculations required for the development of a practical refrigeration unit that has the pumping capability to meet the refrigeration requirements of the hypothermia devices. Although other compounds will perform in a similar way, carbon dioxide was chosen as the refrigeration medium because it has the highest latent heat and the highest overall thermal capacity. Carbon dioxide is also the least toxic and the most environmentally friendly of the alternatives such as N₂O (nitrous oxide). The conclusion based on the documentation and references presented here, is that the phase change concept using liquid carbon dioxide as the working fluid (expendable refrigerant) is a viable solution to the cooling requirement for a Hypothermia device.

Background

The phase change refrigeration concept has been used successfully in many other applications. It is considered for use in Hypothermia devices to cool blood down to 6 - 10 °C and the body temperature to 33 - 34 °C in order to induce mild hypothermia.

Introduction

The development of a device for enabling the induction of mild to moderate Hypothermia in a remote setting requires a compact, efficient, and mobile method of generating sufficient refrigeration capacity for quickly cooling the blood in an extracorporeal circuit. Present mechanical refrigeration units are too bulky and heavy to satisfy these requirements, thus alternative methodology will be investigated. This literature search will evaluate one possible technique for accomplishing this end result. Preliminary research of various medium has resulted in the selection of LCO₂ as a refrigerant based on availability, environmental friendliness, cooling capacity, and its' non-toxic nature.

Purpose

The purpose of this research is to present a detailed evaluation of the viability of the phase change refrigeration as an alternative method for the enabling of mild to moderate hypothermia in a mobile or remote location. The characteristics and calculations necessary for designing an enabling device are also presented.

Description of Apparatus and Setup

No apparatus is required for this literature only search.

Summary of Data and Results**COOLING REQUIREMENTS:**

The following are the cooling requirement goals:

- Blood flow rate in the extra-corporeal circuit **500 ml/min**
- Catheter bore **3mm diameter**
- Blood temperature entering the hear exchanger **37°C**
- Blood temperature leaving the heat exchanger **6-10 °C**
- Operating time per. use **30 min minimum**
- Target temperature of the body **33-34 °C**

The following are the assumptions for preliminary investigation.

- The thermal capacity of blood ($c = 3.8\text{J/g}\cdot\text{°C}$) (.909 BTU/#-°F)
- The density of blood ($\rho = 1060\text{kg/m}^3$) (2.33#/liter)
- Ambient operating temperature is 26°C (78°F)
- The heat exchanger efficiency is 75%

THE PROPERTIES OF LIQUID CO₂:

- Triple point **-56.2°C @ 5.28 kg/cm²A = -69.9°F @ 75.1 psia**
- Critical temperature **31°C = 87.8°F**
- Critical pressure **74.24 kg/cm²G = 1056psig**

- Latent heat of vaporization **13.94 kcal/kg = 23 Btu/lb (-17.8°C; 0°F)**
- Vapor pressure
 - @80°F -- 969 psia**
 - @70°F---853 psia**
 - @60°F---747 psia**
 - @50°F---652 psia**
- Latent heat liquid CO₂ flashed to snow = 113 Btu/Lb (liquid)
- Specific heat capacity = .358 btu/lb/°C
- Total heat to 15°C = 113 +(,358 x 63°C) = **136 Btu/Lb**
- Density ----- **63 #/cu ft @10°F, 42.2 #/cu. Ft. (.67 g/ml) @ 80°F**
- Viscosity -----0.14 Centipoises @ -17.8 °C, .0148 @70°F
 1 stoke =1 poise/density gm/ml;
 viscosity (centistokes)= . 0148 centipoise/.67=**.022**
- Vapor pressure-----about **969 psig @80°F, 853 psig @70°F**

@68°F and 14.7 psia (1atm @20°C)

- Mol wt **44.0**
- Sp. gr (air=1) **1.53**
- Density **.115 #/cu ft**
- Sp vol **8.72 cu ft/lb**
- Sp heat , cp **.199 Btu/lb°F**
- cp/cv=k **1.30**
- a=intermolecular force constant ; for CO₂, **a=366 X10³ n-m⁴/(kgm-mole-deg(K))²**
- boiling point @1 atm= **-78.5°C(-109.3°F)**

Based on these assumptions the heat to be removed and CO₂ flow required:

- Heat to be extracted from the blood: (.909BTU/#°F)(1.17#/min)(55.8°F) =59BTU/min =**1037watts**
- At an efficiency of 75% the heat pump/sink must have a capability of 59/. 75=**79BTU/min (1388watts)**
- Total heat for liquid CO₂ (sum of latent and sensible) is **136 btu/lb**
- CO₂ flow required = 79/136 = .6 lb/min ≈ **380 ml/min**

To supply 30 minutes of cooling then a 20 pound CO₂ liquid tank would suffice.

The following sketch (FIGURE 1) is the preliminary concept that will be used for further development of this cooling method.

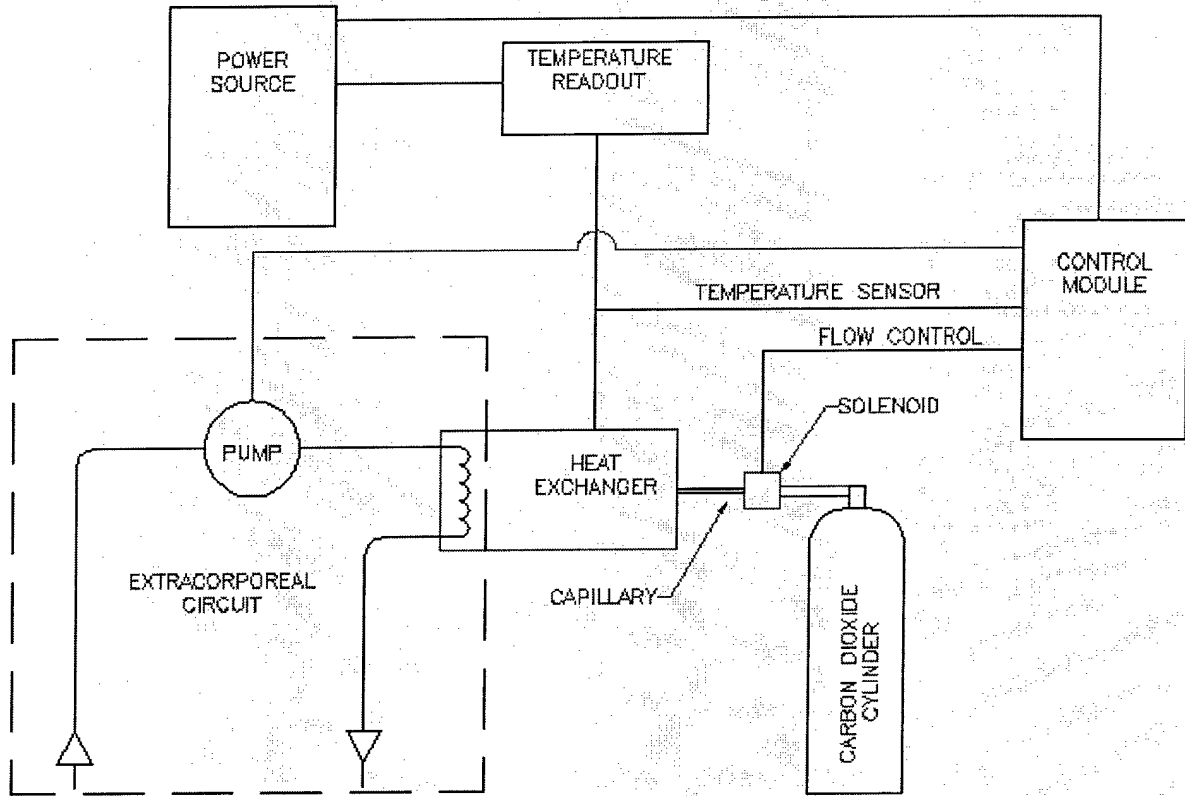

FIGURE 1

Conclusions

Liquid CO₂ is a viable source of the cooling required for a portable hypothermia device and will be pursued through laboratory testing to confirm these findings.

Suggestions for Further Work

It is suggested that the use of LCO₂ be chosen as one of the techniques for further investigation and laboratory experimentation. The success or failure of this approach will depend upon the development of a practical heat exchanger that will take advantage of the available cooling.

APPENDIX G

BIOCONTROL
TECHNOLOGY INC.

TECHNICAL REPORT

#TECHRP REV. D

**RECORD #
273**

TITLE Characterization of FridgeFreeze portable refrigerator/freezer		FILENAME TR_Hypo 020717df.doc	REVISION 00
PROJECT OR PROGRAM NAME Hypothermia Device Research		PROGRAM ROOT NUMBER 78	
PROGRAM TASK DESCRIPTION 20L IV bag cooling methods (Profound Hypothermia)		PROGRAM TASK NUMBER 00	
NAME Dave Felton (test) / Shawn Nesmith (design)		DEPARTMENT Test Engineering	DATE 7/09/02
TECHNICAL AREA Device Characterization			
SUBJECT AND KEY TECHNICAL WORDS Characterization of the cooling capacity of the FridgeFreeze brand portable refrigerator/freezer			
DOCUMENTATION TYPE			
<input type="checkbox"/> Validation	<input type="checkbox"/> Error Budget	<input type="checkbox"/> Reliability	<input type="checkbox"/> Sensitivity
<input type="checkbox"/> Verification	<input type="checkbox"/> Product Support	<input type="checkbox"/> Risk Analysis	<input checked="" type="checkbox"/> Other
ASSOCIATED REPORTS TR_Hypo 020619 DF.doc			

Abstract

This report details the results of the characterization tests performed on the FridgeFreeze brand portable refrigerator/freezer, which is one of the possible candidates to be used on the profound hypothermia project. The freezer was able to chill a 20L bag of saline solution at room temperature down to 0°C in roughly 5 hours, and was able to easily maintain it at that temperature.

Background

The Hypothermia Program is a research and development program funded by the Department of the Army in cooperation with Safar Research Institute in Pittsburgh, PA. The proposed device will store large volumes (10 to 40L) of sterile cold flush solution at a temperature of -5 to 5°C . The sterile cold flush solution will be administered to a subject at a delivery rate of about 2 L/min, lowering the core body and brain temperature to around 10 to 20°C causing profound hypothermia. Initially this device is to be used in a hospital emergency room environment with sufficient external power. However, further consideration must be given to develop a device that can be transported by emergency vehicles, such as ambulances and /or helicopters. Therefore, the device will need to have an internal power supply, or operate off the emergency vehicles limited power supply.

Introduction

One of the proposed methods of administering profound hypothermia is to chill a 20L IV bag of sterile cold flush solution to 0°C which will then be used to flush the body's circulatory system at a rate of about 2 L/min. To chill the filled 20L IV bag, Biocontrol engineering procured a portable refrigerator/freezer with a 60L inner tub capacity from FridgeFreeze in San Diego, CA.

Purpose

The purpose of this test was to characterize the portable freezer's capability to chill a 20L IV bag filled with a saline solution from room temperature down to 0°C and maintain that temperature.

Description of Apparatus and Setup

The factory temperature control of the portable freezer had to be bypassed to allow a closed loop control of the IV bag's water temperature to an accurate setpoint. The thermostat included in the freezer was disconnected from the compressor's controller and an Omega Model CN132 temperature controller was installed. The temperature feedback for this controller was a hypodermic needle T-type thermocouple that was punctured into the IV bag. Power for the Omega controller was a separate 12VDC supply. The controller was set up to be an ON/OFF control, with a 1 degree bandwidth, and in cooling mode, so that the output relay would close when the IV bag water went above the setpoint.

The DC voltage and current input to the compressor controller was measured using two DMMs (Keithley 1000 and Fluke 73, respectively). The AC current input to the freezer was measured using a Extech 38095C Amp Clamp. A Yokogawa MV112 datalogger was used to record significant temperatures which included the ambient temperature inside the freezer, room temperature, the freezer inner and outer wall temperatures, and the IV bag water temperature. Figure 1 shows a schematic of the test setup.

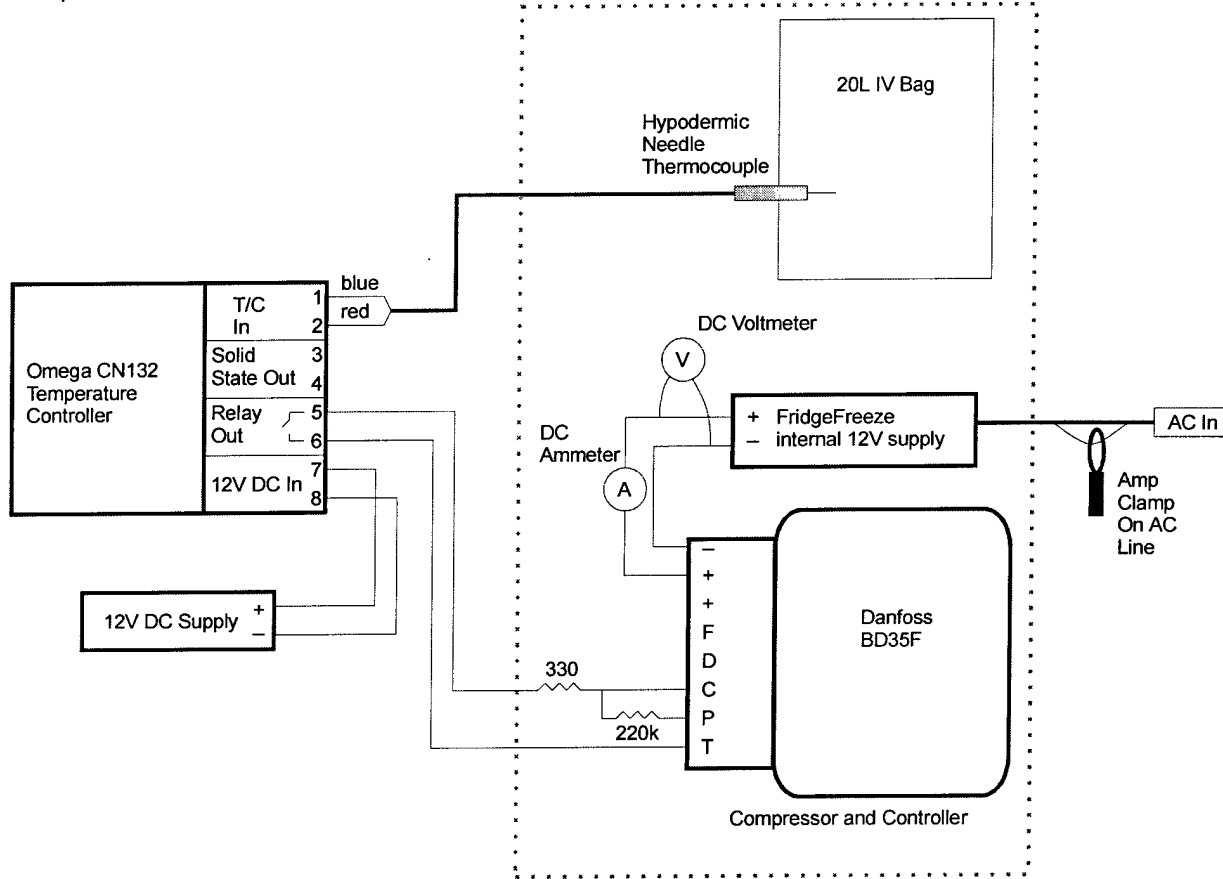

Figure 1

Figure 2 below shows the FridgeFreeze with the service panel removed to provide access to the compressor.

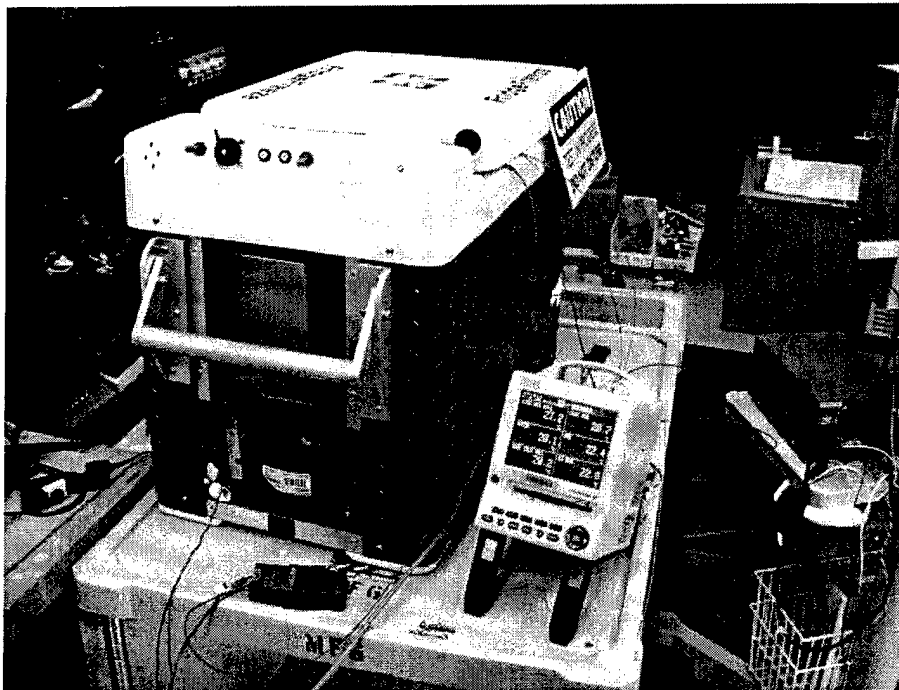

Figure 2

Figure 3 shows the compressor and Omega control in a little more detail.

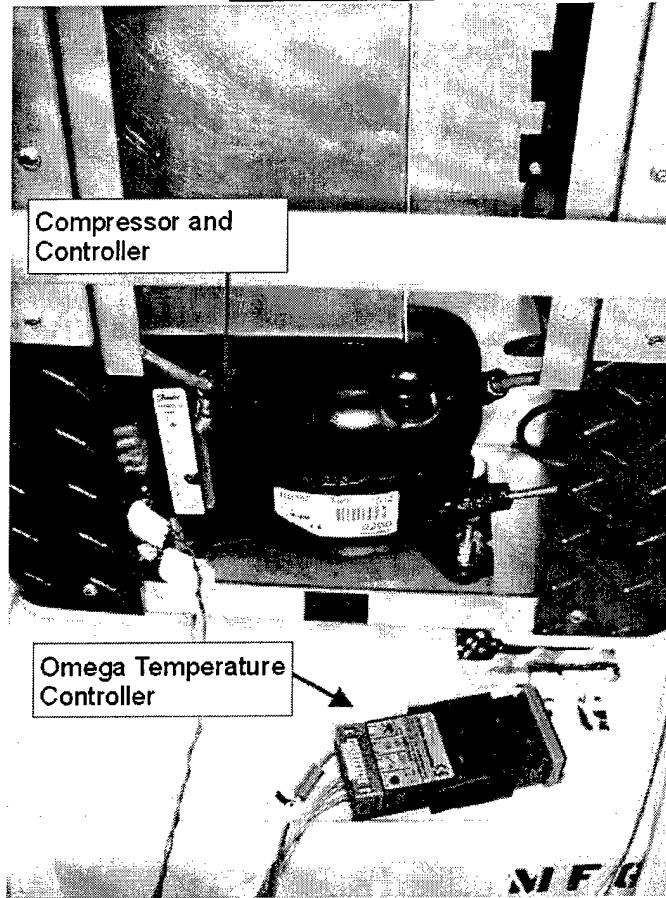

Figure 3

Figure 4 shows the filled 20L IV bag inside of the freezer with the hypodermic needle thermocouples punctured into it. A patch of silicon sealer was allowed to cure on the bag first to help prevent leaking around the puncture holes.

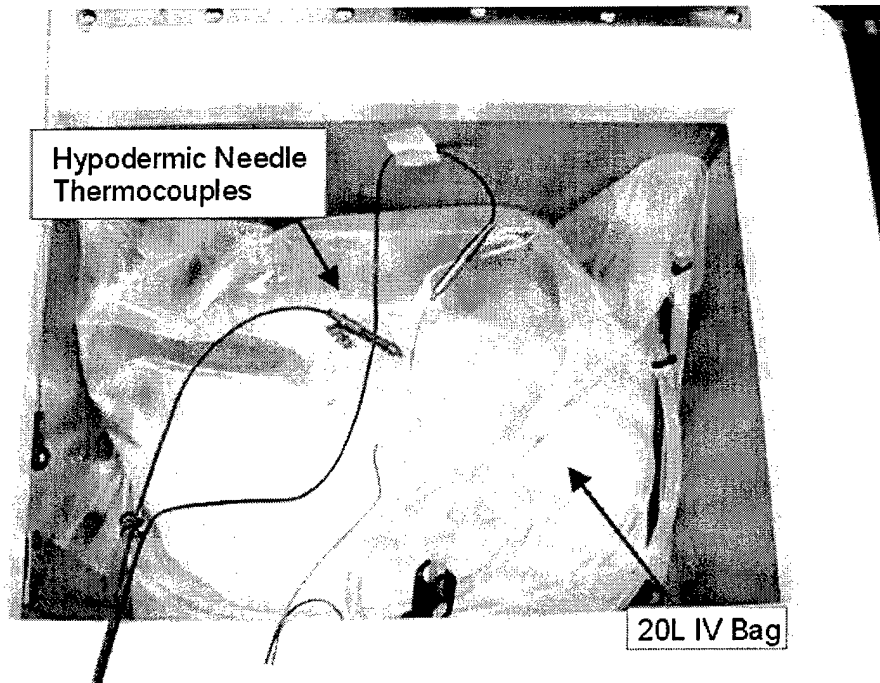

Figure 4

Summary of Data and Results

Figure 5 shows the 20L IV bag water temperature (dark blue line) from turn-on through roughly 9 hours of running. The initial setpoint on the Omega controller was 0°C. At about the 5 hour mark, the temperature of the water reached roughly 2°C and started to settle in. At roughly 6 hours, the setpoint was yoked to -2°C to compensate for what appears to be a 2°C difference in what the Omega controller reads and what the Yokogawa recorder reads. The water temperature then stabilized around 0°C. Also at the 6 hour mark, the freezer was opened and the bag was shaken, stirring the water, in order to see how much of a temperature gradient there was in the bag. The temperature only increased roughly 0.5°C indicating that there wasn't much of a temperature difference throughout the water. The other two lines show the freezer inner wall temperature and the freezer inner ambient temperature.

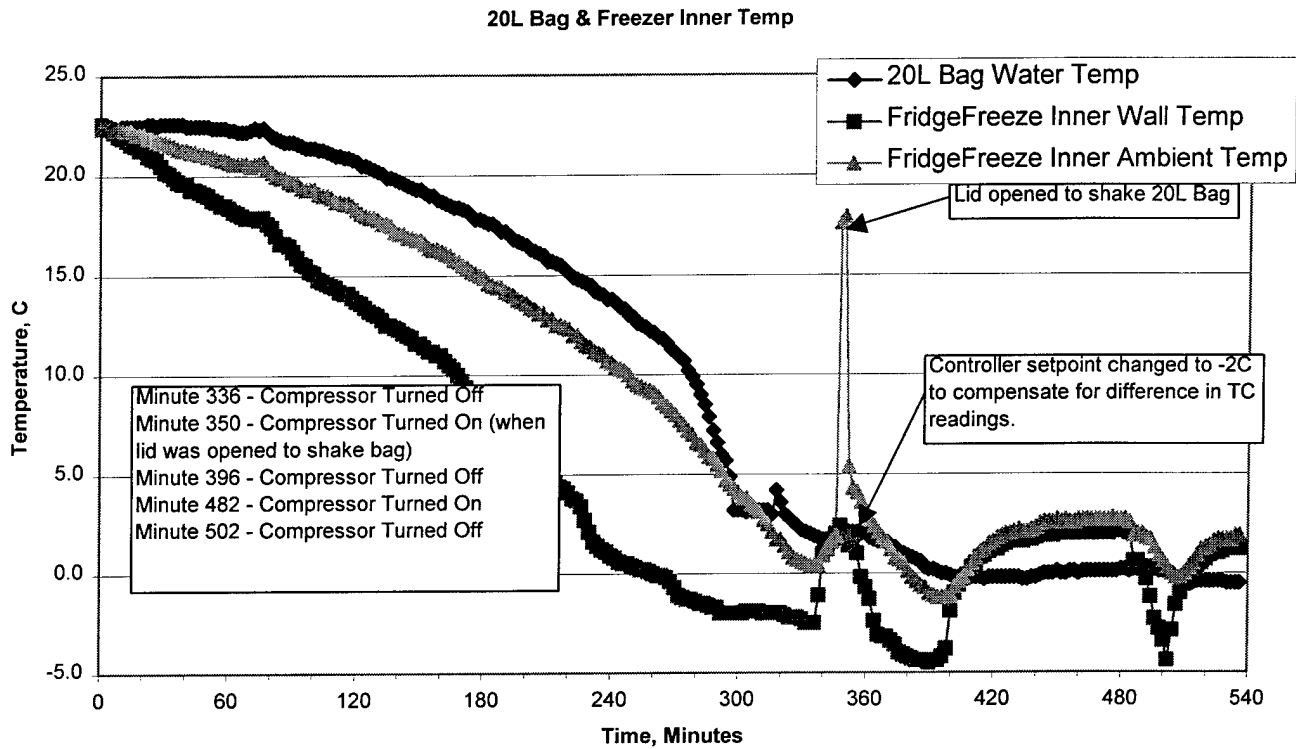

Figure 5

Figure 6 shows the room ambient and the freezer outer case temperature over this same time period. The FridgeFreeze uses the outer case as part of the condenser, so it warms up while the refrigeration system is running.

Freezer Outer Case Temp

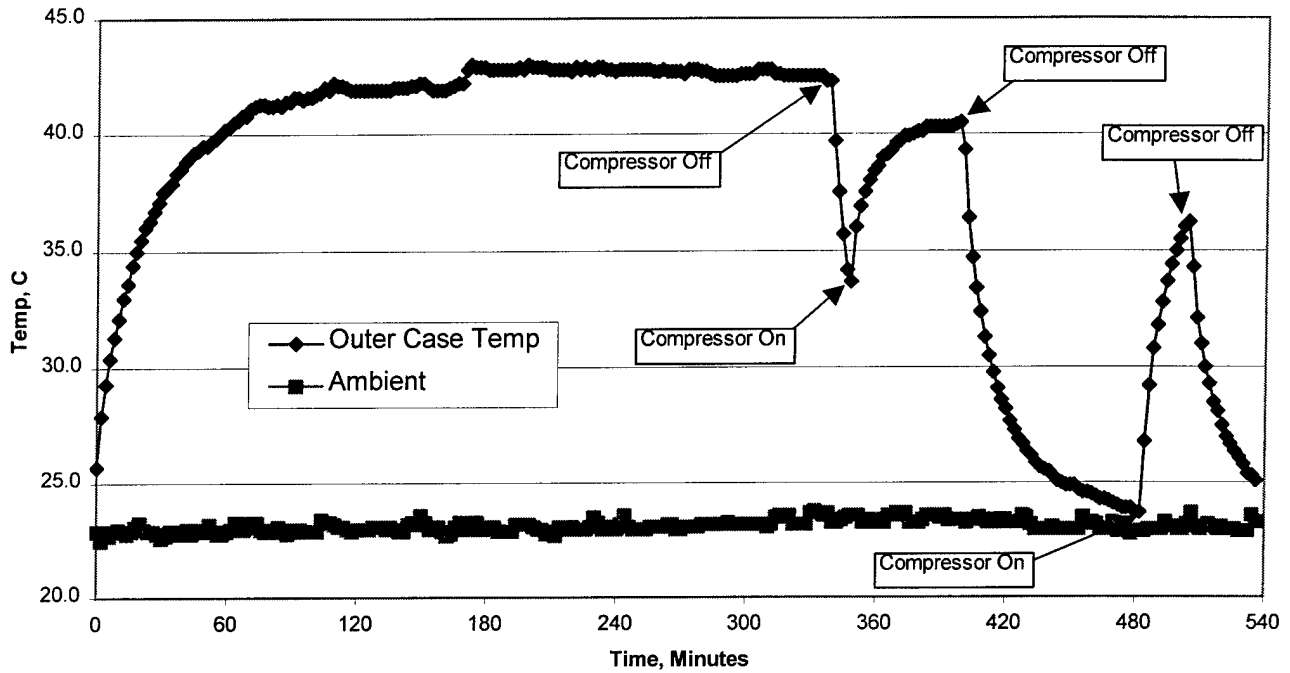

Figure 6

Once the bag reached 0°C, the temperature controller and compressor was shut off, and the IV bag was allowed to warm up naturally. The purpose of this test was to see how well the freezer was insulated. Figure 7 below shows the result over a 5 day span.

Natural Warming of 20L Bag and Freezer

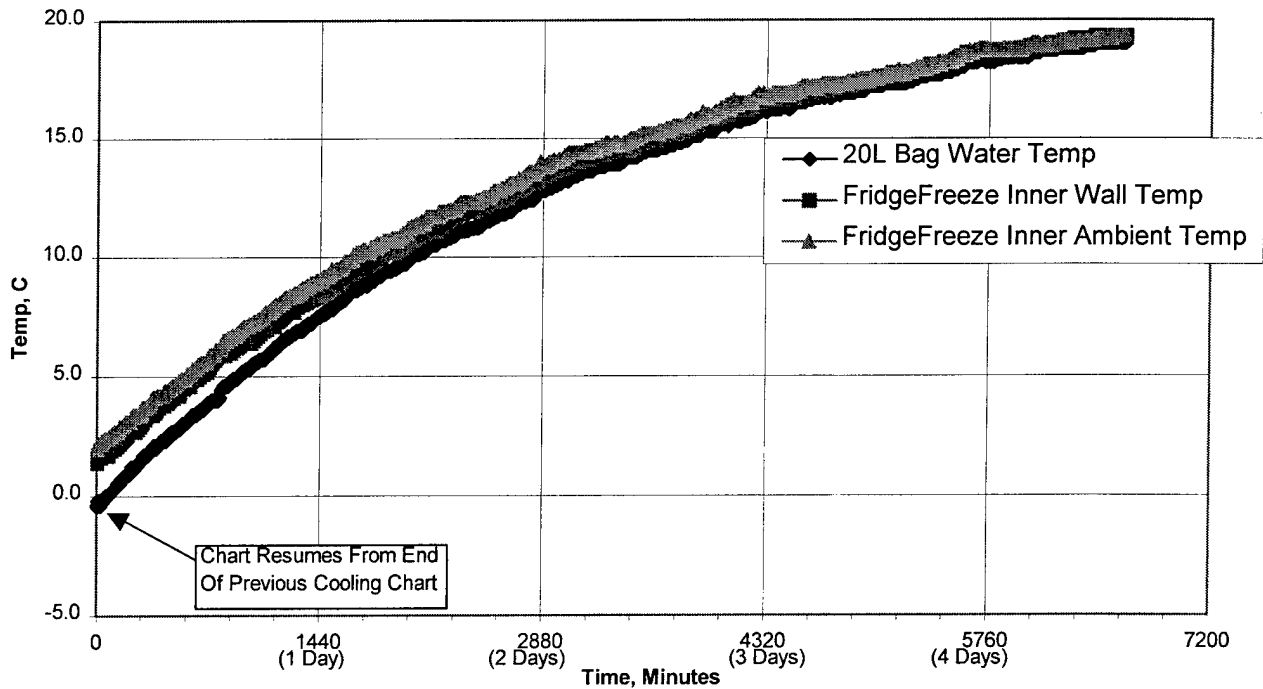

Figure 7

The final test was to see how well the FridgeFreeze with the Omega controller would maintain the IV bag temperature. The system was turned back on and allowed to bring the temperature back down to 0°C. Once there, the data acquisition was again started and allowed to capture data for roughly 16 hours. Figure 8 shows the result. The IV bag water temperature was held within 1°C over the test. The Omega controller's bandwidth could be set tighter than the 1 degree that was used for this test, possibly narrowing the temperature swing of the water further if needed.

FridgeFreeze 20L Bag Continuous Run

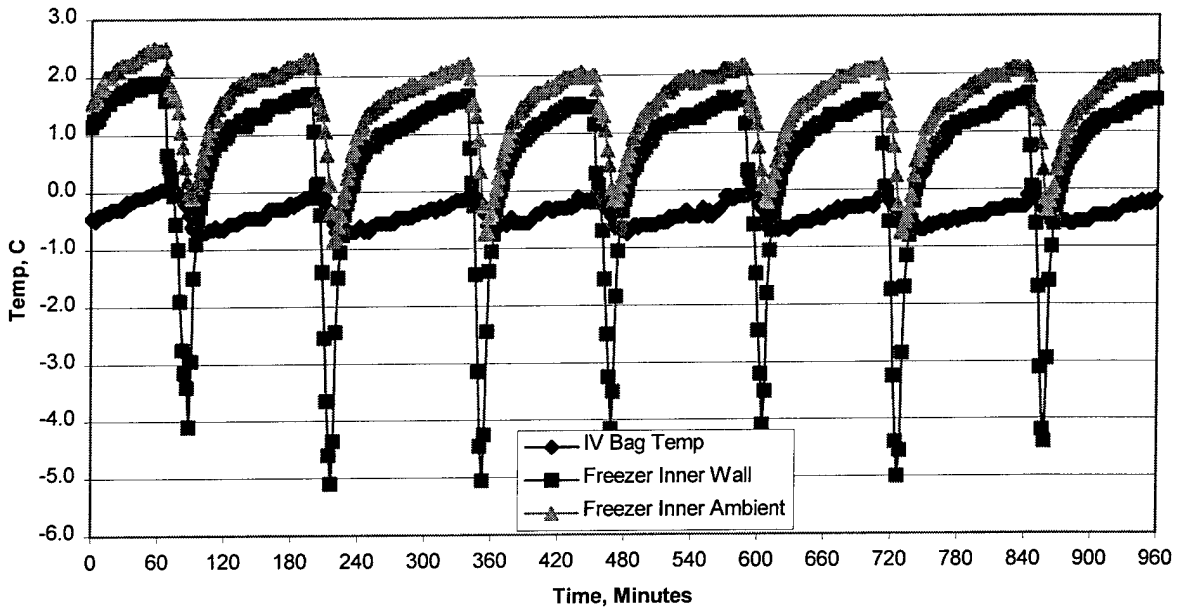

Figure 8

The DC power from the FridgeFreeze internal 12V power supply to the compressor controller was also monitored. At the beginning of the test, the results were 3.44A DC at 14.75V DC. After 5 hours of constant running, the results did not change much: 3.75A DC at 14.5V DC. The AC current on the 120VAC line was monitored with an amp clamp. This value stayed constant at 0.7A AC throughout the test.

Conclusions

Since this was a characterization test, there are no conclusions to be derived for the recorded data.

Suggestions for Further Work

None

APPENDIX H

BIOCONTROL
TECHNOLOGY INC.

TECHNICAL REPORT
#TECHRP REV. D

RECORD #
276

TITLE Thermoelectric Cooler Performance Testing		FILENAME TR_Hypo020822 WN	REVISION 00
PROJECT OR PROGRAM NAME Hypothermia Device Research		PROGRAM ROOT NUMBER 78	
PROGRAM TASK DESCRIPTION Device Research and Testing		PROGRAM TASK NUMBER 00	
NAME William Novak		DEPARTMENT Mechanical Engineering	DATE 08/22/02
TECHNICAL AREA Refrigeration Concepts			
SUBJECT AND KEY TECHNICAL WORDS Hypothermia, Cooling, Refrigeration, Thermoelectric, Heat Exchanger, Blood			
DOCUMENTATION TYPE			
<input type="checkbox"/> Validation	<input type="checkbox"/> Error Budget	<input type="checkbox"/> Reliability	<input type="checkbox"/> Sensitivity
<input type="checkbox"/> Verification	<input type="checkbox"/> Product Support	<input type="checkbox"/> Risk Analysis	<input checked="" type="checkbox"/> Other
ASSOCIATED REPORTS TR_Hypo 020618 SN.doc, TR_Hypo 020805 WN.doc			

Abstract

This report presents the technical research results necessary to evaluate the Thermoelectric Cooling concept for use in mild to moderate hypothermia device(s). As part of the research for the Hypothermia Program, thermoelectric cooling has been considered as the primary cooling method for the blood supply circuit. The Thermoelectric Cooling concept was investigated as a potential method that satisfies the requirements of a compact, simple and reliable method to cool blood flow to 6°C within a hospital environment. The system that was used for testing as part of evaluating the Thermoelectric Cooling method failed to cool the process fluid down to 6°C at a flow rate of 500ml/min. However, it is logical to assume that the reasons for failure lies in the specific system used to evaluate the Thermoelectric Cooling concept and that a more efficient system design should be considered for further testing.

Background

The theories behind the operation of thermoelectric cooling can be traced back to the early 1800s. Jean Peltier discovered there is a heating or cooling effect when electric current passes through two conductors. Thomas Seebeck found two dissimilar conductors at different temperatures would create an electromotive force or voltage. William Thomson (Lord Kelvin) showed that over a temperature gradient, a single conductor with current flow, will have reversible heating and cooling. With these principles in mind and the introduction of semiconductor materials in the late 1950s, thermoelectric cooling has become a viable technology for small cooling applications.

The basic concept behind thermoelectric (TE) technology is the *Peltier effect*, which occurs whenever electrical current flows through two dissimilar conductors; depending on the direction of current flow, the junction of the two conductors will either absorb or release heat. A *Peltier device* can be constructed, in its simplest form, around a single semiconductor 'pellet' which is soldered to electrically conductive material on each end (usually plated copper). In this 'stripped-down' configuration, the second dissimilar material required for Peltier effect, is usually the copper connection path to the power supply. The heat will be moved (or 'pumped') in the direction of charge carrier movement throughout the circuit. It is the charge carriers that transfer heat.

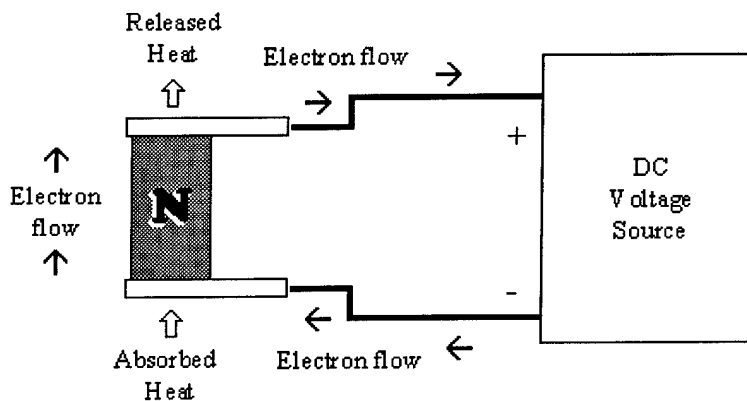

While a simple thermoelectric device can be made with a single semiconductor pellet, an appreciable amount of heat cannot be pumped through it. In order to give a TE device greater heat pumping capacity, multiple pellets are used together.

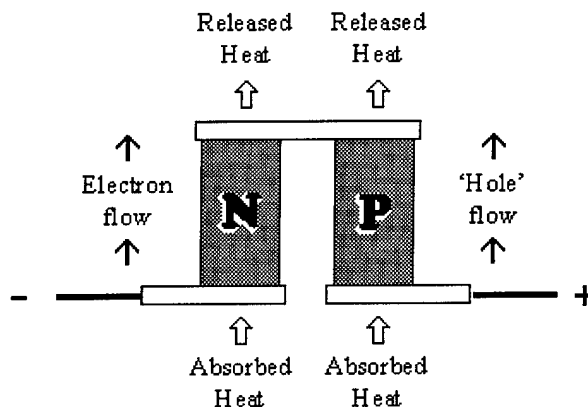

By arranging N and P type pellets in a 'couple' and forming a junction between them with a plated copper tab, it is possible to configure a series circuit, which can keep all of the heat moving in the same direction. As shown in the illustration above, with the free (bottom) end of the P type pellet connected to the positive voltage potential and the free

(bottom) end of the N type pellet similarly connected to the negative side of the voltage, an interesting phenomenon takes place. The positive charge carriers (i.e. 'holes') in the P material are repelled by the positive voltage potential and attracted by the negative pole; the negative charge carriers (electrons) in the N material are likewise repelled by the negative potential and attracted by the positive pole of the voltage supply. In the copper tabs and wiring, electrons are the charge carriers; when these electrons reach the P material, they simply flow through the 'holes' within the crystalline structure of the P type pellet (it is the charge carriers inherent in the material structure which dictate the direction of heat flow). Thus the electrons flow continuously from the negative pole of the voltage supply, through the N pellet, through the copper tab junction, through the P pellet, and back to the positive pole of the supply. Because two different types of semiconductor material are used, the charge carriers and heat are all flowing in the same direction through the pellets (bottom to top in the illustration above). Using these properties of the TE 'couple', it is possible to team many pellets together in rectangular arrays to create practical thermoelectric modules. These devices cannot only pump appreciable amounts of heat, but with their series electrical connection, are suitable for commonly available DC power supplies.

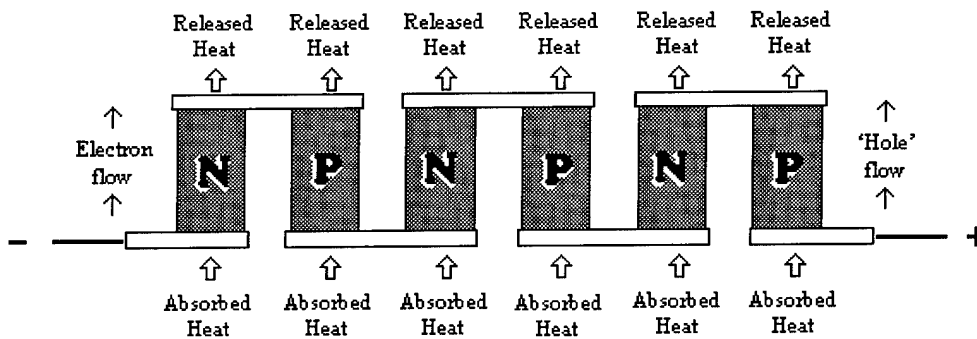

Multi-couple configuration increases heat-pumping capacity

Fabricating devices with multi-pellet arrays requires a mechanical means to hold everything together. The conductive tabs are mounted to thin ceramic substrates. The outer faces of the ceramics are then used as the thermal interface between the Peltier device and the 'outside world'. Ceramic materials have become the industry standard for this purpose because they represent the best compromise between mechanical strength, electrical resistivity, and thermal conductivity.

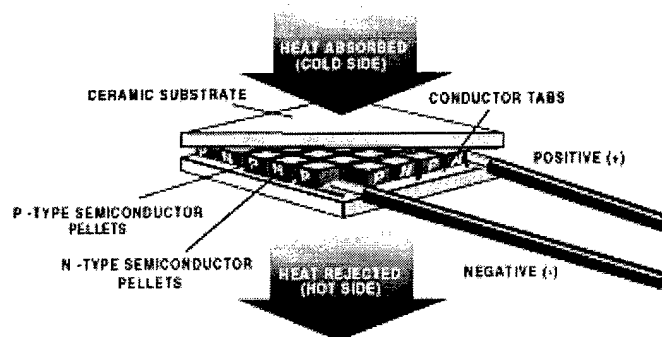

Introduction

The project goal is to develop a device for quickly chilling blood to induce a state of mild to moderate hypothermia. A thermoelectric cooling unit will be incorporated within the Hypothermia device to create a compact, efficient and reliable method of chilling blood, which will be simple to use by requiring little setup and changeover of disposable components. Present mechanical refrigeration units are large and require frequent preventive maintenance. Thermoelectric cooling will be investigated as an alternative to current mechanical refrigeration systems.

Purpose

The research is conducted to develop and evaluate a cooling concept incorporating thermoelectric units coupled with a heat exchanger system. The goal is to utilize a heat exchanger, which will remove heat from a thermoelectric unit(s), which ultimately cools blood in an extracorporeal circuit to induce a hypothermic state.

Description of Apparatus and Setup

The experimental setup (figure 1) consists of a large TEC unit (*Thermo Electric Chiller*), heat exchanger loop, process fluid (blood) pump, and associated monitoring and control devices. Process fluid is pumped from the supply reservoir into the TEC unit. The TEC unit is equipped with an associated power supply and a PID temperature controller. The temperature controller regulates electrical power to the TEC unit based upon the setpoint value input to the temperature controller. As it passes through the TEC unit, the process fluid is chilled to the setpoint value of the temperature controller. After passing through the TEC unit, the process fluid is collected in an output reservoir. The TEC unit absorbs heat from the process fluid and that heat is removed from the TEC unit by a coolant fluid that circulates between the plates of the TEC unit. The coolant fluid dissipates the accumulated heat (from the process fluid via the TEC) through fan-cooled heat exchangers. Two heat exchangers are connected in series for increased heat transfer rate. After exiting the heat exchangers, the coolant fluid is accumulated in a 5-gallon reservoir, which also acts as a heat sink. The coolant fluid is then pumped from the reservoir and recirculated through the TEC unit. Thermocouples (Type K) were used to monitor temperature levels of the process fluid, coolant fluid and TEC surface at various points within the experimental setup. Tap water was used as the process fluid due to thermodynamic properties similar to blood. Tap water was supplied at an inlet temperature range of 22°C to 46°C. During the experimental trials, environmental conditions within the laboratory were: temperature 18°C – 23°C, normal atmospheric pressure 14.7psia, relative humidity 56%.

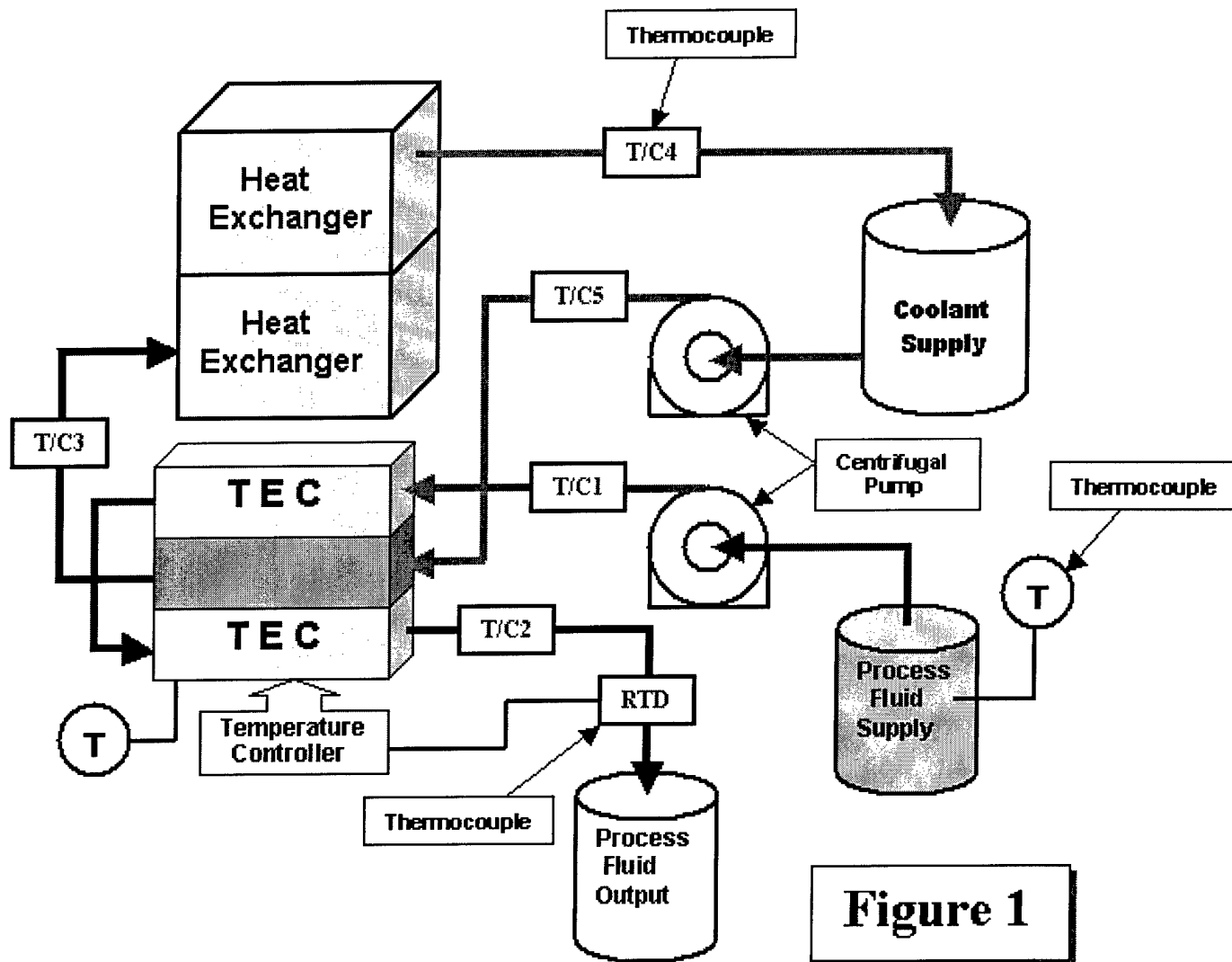

Figure 1

The TEC unit consists of two "chiller" sections that transfer heat to a common coolant layer that is between the two TEC "chiller" sections as shown in Figure 2. The TEC "chiller" sections are connected in series via tubing. The process fluid flows through 3/8" diameter x .013" PFA tubing. The tubing, for the process fluid, has two loops in each of the TEC "chiller" sections as shown in Figure 3. The tubing nests into grooves cut into the inner tubing plate and are slightly compressed when the outer tubing plate is bolted to the inner tubing plate. The TEC "chiller" sections consist of a layer of 36 individual TEC elements electrically connected in series (Figure 4). The individual TEC elements are 40mm square. The coolant plate is a heat sink for the TEC "chiller" sections. The coolant plate has multiple channels bored within it through which coolant water passes and absorbs heat from the TEC "chiller" sections. After exiting the TEC unit, the coolant water passes through two, fan cooled, liquid-to-air heat exchangers that are connected in series (Figure 5). The coolant water is then recirculated through the TEC unit.

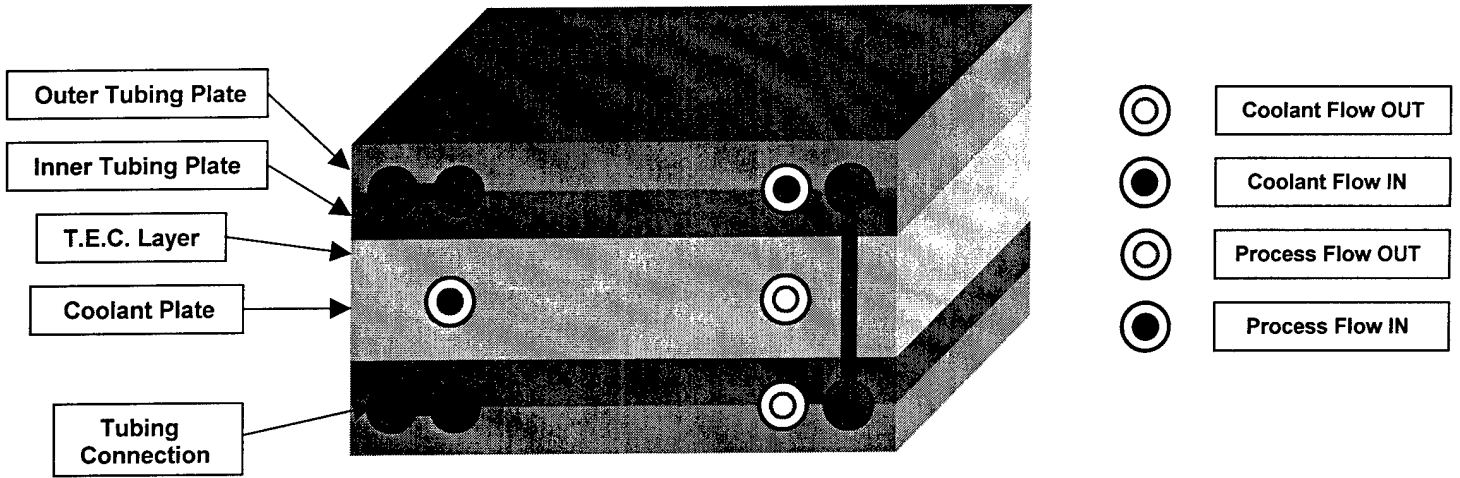

Figure 2

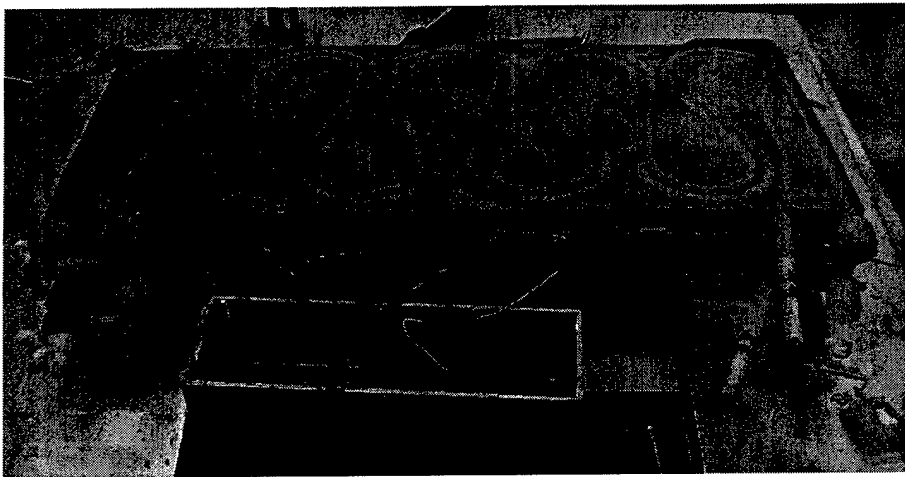
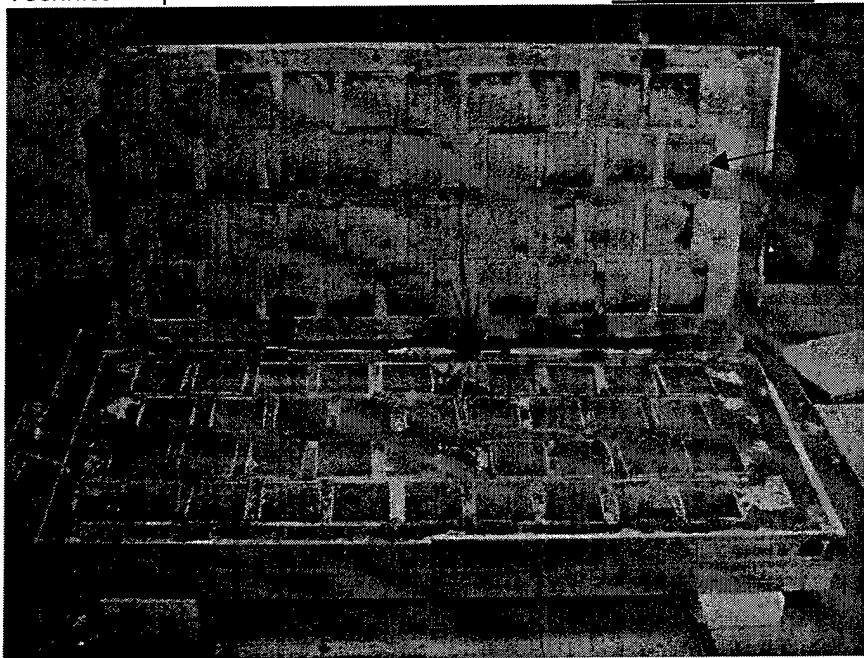

Figure 3



TEC element

Figure 4

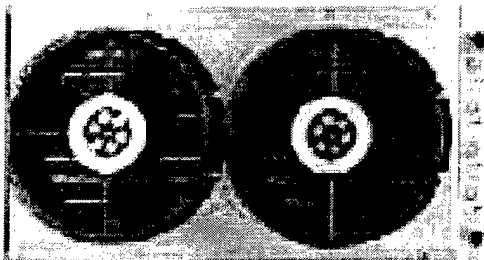

Figure 5

System components:

The experimental setup was assembled according to the diagram shown in Figure 1.

TEC Circulation Loop

- (2) Process Fluid Supply/Output Reservoirs
 - HDPE cylindrical tank w/cover, spigot, 7.5 gallon - Cole-Parmer 06317-56
- (A/R) Tubing – process fluid
 - Inlet – Silicone tubing, Red, 3/8" ID, 1/2" OD, - Cole-Parmer 96150-08
 - Outlet – Silicone tubing, Blue, 3/8" ID, 1/2" OD, - Cole-Parmer 96150-28
- (2) Flowmeters – process fluid inlet/outlet
 - Direct reading, 200-3000ml/min-flow rate – Cole-Parmer 32461-42
- (1) Pressure gauge
 - Battery powered, 0-100psi – Cole-Parmer 68925-10
- (1) Process fluid pump
 - Bio-Console pump speed controller – Medtronic Model 550
- (1) Blood pump (adult)
 - Bio-pump adult blood pump – Medtronic 95201
- (1) Thermoelectric Unit
 - Liquid-to-Liquid heat Exchanger with temperature controller and power supply
 - Solid State Cooling Systems – Cleanstream 1850 Controller, Package -S
- (2) Thermocouples
 - Type K pipe plug thermocouple probe, 1/4"MNPT plug – Cole-Parmer 08516-73
- (1) Scanning Thermometer
 - Digi-Sense 12-channel scanning thermometer – Cole-Parmer 92000-00
- (A/R) Assorted tubing/pipe fittings

Coolant Circulation Loop

- (2) Heat Exchangers
Liquid to Air heat exchanger with fan plate and fans – Thermacore 5360-BNN
- (3) Thermocouples
Type K pipe plug thermocouple probe, ¼"MNPT plug – Cole-Parmer 08516-73
- (1)* Scanning Thermometer (same unit used in TEC circulation loop)
Digi-Sense 12-channel scanning thermometer – Cole-Parmer 92000-00
- (1) Coolant supply reservoir
HDPE cylindrical tank w/cover, spigot, 5.0 gallon - Cole-Parmer 06317-51
- (1) Coolant pump (centrifugal) – Trials 01 – 07
1/15HP, 3.0 gpm max, 18 ft max head – March BC-3CP-MD
- (1) Coolant Pump (centrifugal) – Trials 08 –23
Iwaki Magnet pump, 35.6 gpm max, 39 ft max head – Cole-Parmer 72010-80
- (A/R) Tubing – coolant fluid
Silicone tubing, platinum cured, 5/8" ID, 7/8" OD, - Cole-Parmer 95802-25
- (1) Flowmeter
Direct reading, 1-10 gpm flow rate – Cole-Parmer 32466-50
- (A/R) Assorted tubing/pipe fittings

Summary of Data and Results

COOLING REQUIREMENTS

- Blood flow rate in extra-corporeal circuit: **500 ml/min**
- Blood temperature entering Thermoelectric chiller: **37°C**
- Blood temperature exiting Thermoelectric chiller: **5°C**
- Density of blood: ρ **1060 kg/m³**
- Specific heat capacity of blood: c **3800 J/kg°C**

Converting blood flow rate:

$$(.500\text{L/min})(\text{min}/60 \text{ sec})(10^3\text{cm}^3/\text{L})(\text{m}^3/10^6\text{cm}^3) = \mathbf{8.333 \times 10^{-6}\text{m}^3/\text{sec}}$$

Calculating mass flow rate of blood: m'

$$(8.333 \times 10^{-6}\text{m}^3/\text{sec})(1060\text{kg}/\text{m}^3) = \mathbf{8.833 \times 10^{-3}\text{kg}/\text{sec}}$$

Calculating heat flow rate of blood: $Q' = m'c\Delta T$

$$(8.833 \times 10^{-3}\text{kg}/\text{sec})(3800 \text{ J}/\text{kg}^\circ\text{C})(37^\circ\text{C} - 5^\circ\text{C}) = \mathbf{1074.093 \text{ J}/\text{sec} \text{ (watts)}}$$

$$(1074.093 \text{ W})((3.413 \text{ BTU}/\text{hr})/\text{W}) = \mathbf{3665.88 \text{ BTU}/\text{hr}}$$

From TEC manufacturer:

TEC will generate approximately **4000 watts** at design conditions: 500ml/min, 6°C output

Total heat load of system:

$$\text{Process fluid heat} + \text{TEC generated heat} = 1074.093 \text{ watts} + 4000 \text{ watts} = \mathbf{5074.093 \text{ watts}}$$

Twenty-two trials were completed to evaluate the performance of TEC chiller system for use in a hypothermic cooling device. Three trials were conducted to evaluate the TEC performance in a heating role. All trials were conducted following identical procedure:

- TEC unit was powered-up and setpoint value entered for process fluid output temperature

- TEC unit was run, with coolant fluid circulating through TEC, until setpoint value stabilized
- Process fluid pump started. Pumping water from process supply reservoir
- At predetermined intervals, temperature readings taken for TEC surface, process fluid and coolant fluid at multiple locations in system
- Process repeated in both heating and cooling modes at various input temperatures and flow rates

Before the process fluid can be circulated through the TEC unit, the temperature of the TEC unit must be reduced from room temperature (20°C) to the setpoint of the temperature controller. This step takes approximately 5-10 minutes depending on the value of the setpoint.

Analysis of test data from the trials 1 through 7 clearly shows that the TEC unit can not lower the process fluid output temperature to the setpoint value even at lower flow rates and lower fluid input temperature at ambient (23.3°C). The coolant loop cannot dissipate the total heat load from the TEC unit at the 1.75 gpm rate (March BC-3CP-MD pump).

Analysis of test data from trials 8 through 23 shows that TEC performance increases with the substitution of a larger coolant pump: Iwaki Magnet pump, 39 ft head, 3.5 gpm. However, even with a larger pump, coolant flow rate was insufficient to dissipate the heat load from the TEC unit with a process flow rate of 500ml/min and inlet temperature of 37°C. The best result, at specified conditions (500ml/min, 37°C inlet) was a process outlet temperature of 19.74°C during Trial 23. The desired process fluid output temperature of 6°C was achieved in Trial 10 when the process fluid flow rate was maintained at 500ml/min, but the process fluid inlet temperature was decreased to 30°C.

Decreasing the process fluid flow rate to 300ml/min allowed the TEC system to attain the 6°C process fluid outlet temperature even at an inlet fluid temperature of 46°C (Trial 11A). When the process fluid flow rate was increased to 400ml/min, the desired 6°C outlet temperature could not be reached.

In Trials 2,3,6 the TEC unit was used in a 'heating' role. With the smaller coolant pump (1.75gpm) and due to the large amount of heat generated by the operation of the TEC unit (4000 watts), the process fluid temperature quickly rose and stabilized at the setpoint value. The process fluid flow rate was only at 300ml/min level for Trials 2,3,6. However, at the rate of temperature increase during the trials, it is safe to assume that at 500ml/min, the process fluid temperature would also have risen quickly to the elevated setpoint value.

Experimental Test Results Summary

TEC Heating/Cooling Trials

Trial #	Date	Start Time	Stop Time	Process Flow Rate ml/min	Coolant Flow Rate gpm	Fluid Input Temp °C	Setpoint °C	Setpoint Achieved °C
1A	5/28/2002			500	1.75	36.7	10.0	18.90
1B	5/28/2002			200	1.75	35.8	10.0	20.00
2	6/4/2002			300	1.75	23.3	38.0	38.00
3	6/4/2002			300	1.75	23.3	43.0	43.00
4	6/4/2002			300	1.75	23.3	20.0	20.00
5	6/6/2002	9:00	9:45	300	1.75	23.3	15.0	15.00
6	6/6/2002	9:48	10:30	300	1.75	23.3	43.0	43.00
7	6/6/2002	10:34	11:30	300	1.75	23.3	10.0	16.82
8	6/13/2002	9:20	10:00	500	3.5	22.0	6.0	6.00
9	6/13/2002	10:23	10:58	500	3.5	40.0	6.0	21.61
10	6/13/2002	2:46	3:16	500	3.5	30.0	6.0	6.00
11A	6/13/2002	4:14	4:54	300	3.5	46.0	6.0	6.00
11B	6/13/2002	4:54	5:10	500	3.5	46.0	6.0	24.62↑
12	6/14/2002	10:30	11:00	300	3.5	40.0	6.0	6.00
13	6/14/2002	1:55	2:50	400	3.5	44.0	6.0	20.51
14	6/14/2002	3:50	4:50	400	3.5	37.0	6.0	16.64
15	6/17/2002	10:25	10:45	300	3.5	22.6	6.0	6.00
16	6/17/2002	11:01	11:46	300	3.5	37.0	6.0	12.47
17	6/17/2002	1:34	2:34	300	3.5	40.0	6.0	15.61
18	6/17/2002	2:53	3:48	400	3.5	37.0	6.0	16.98
19	6/17/2002	4:28	5:18	400	3.5	23.9	6.0	11.85
20	6/18/2002	10:20	11:20	400	3.5	40.0	6.0	16.85
21	6/18/2002	1:38	2:18	500	3.5	40.0	6.0	20.16
22	6/18/2002	3:00	3:50	500	3.5	23.2	6.0	12.80
23	6/18/2002	4:15	5:00	500	3.5	37.0	6.0	19.74

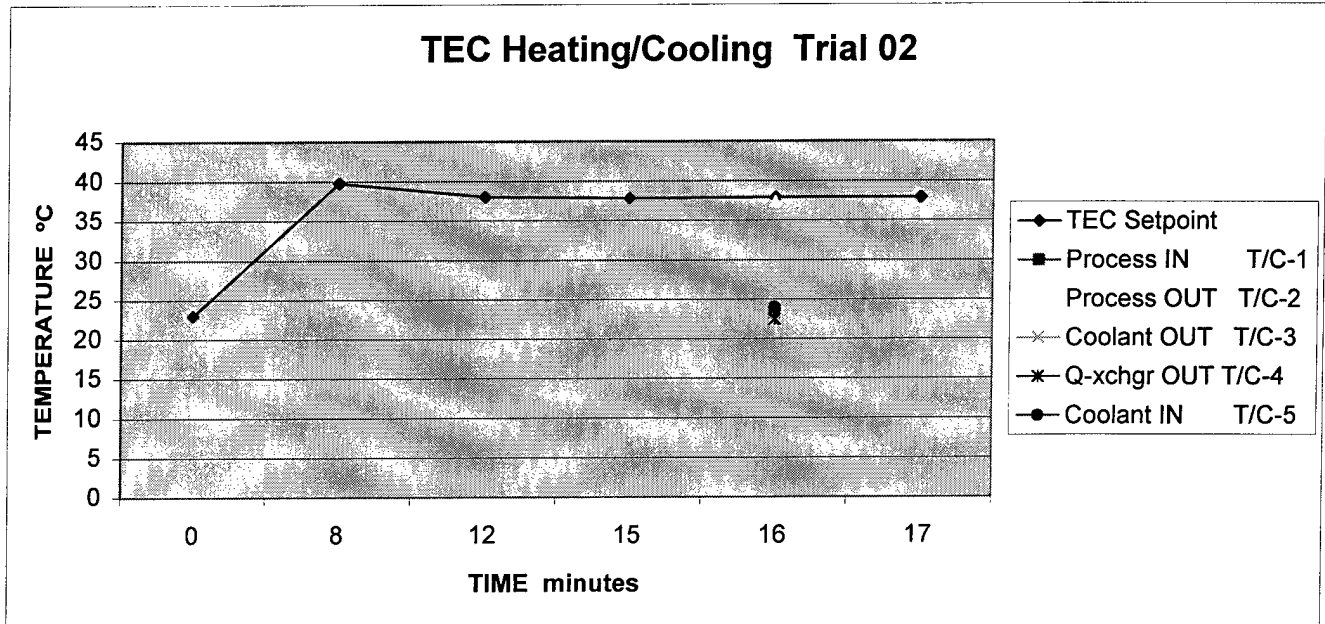

Process Flow Rate = 0.3L/min

Coolant Flow Rate = 1.75gpm

Target = 38°C

Ambient = 23.0°C

	TIME minutes					
	0	8.00	12.00	14.50	15.75	17.00
Process IN T/C-1	23.00	39.77	38.00	37.81	37.90	37.91
Process OUT T/C-2					37.39	
Coolant OUT T/C-3					22.22	
Q-xchgr OUT T/C-4					22.50	
Coolant IN T/C-5					24.00	

Cleanstream 1850-B Thermoelectric Heat Exchanger
 Switchback 6600 CE power Supply
 Yokogawa UT-450 Temperature Controller

Pump March BC-3CP-MD 1/15HP
 3.0 gpm max flow rate
 18 ft max head

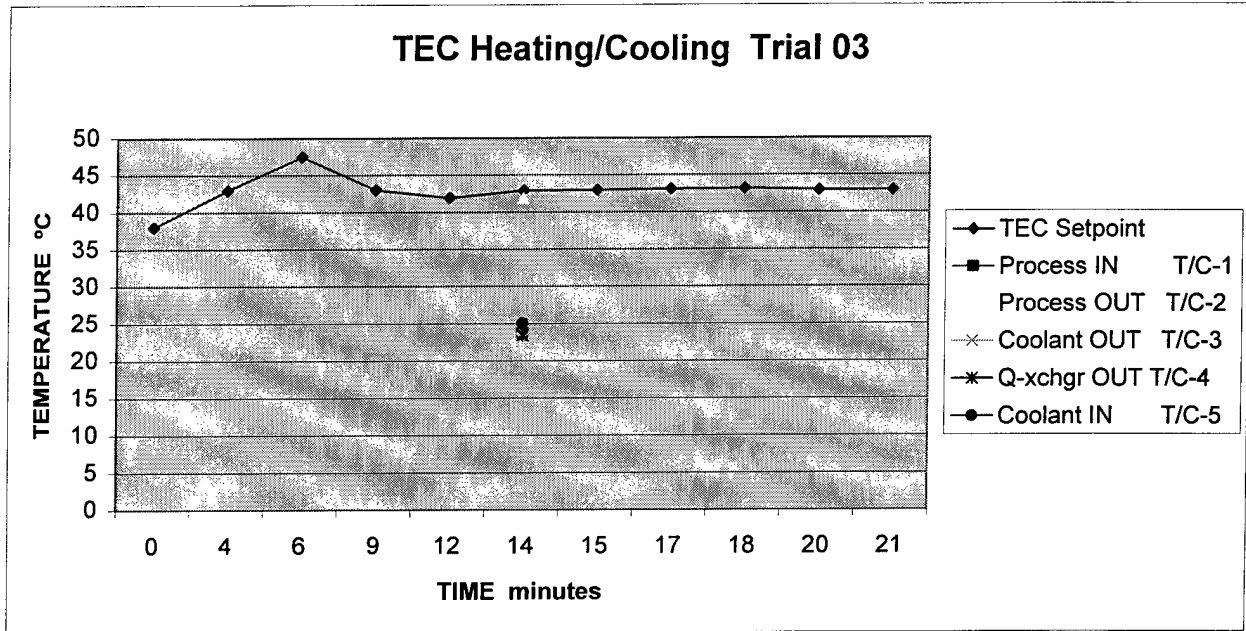

Process Flow Rate = 0.3L/min

Coolant Flow Rate = 1.75gpm

Target = 43°C

Ambient = 23°C

	TIME minutes										
	0	3.75	6.25	9.00	12.00	14.25	15.00	16.50	18.00	19.50	21.00
Process IN T/C-1	38.00	43.00	47.50	43.00	41.94	23.78					
Process OUT T/C-2						41.89					
Coolant OUT T/C-3						23.00					
Q-xchgr OUT T/C-4						23.39					
Coolant IN T/C-5						25.06					

Cleanstream 1850-B Thermoelectric Heat Exchanger
 Switchback 6600 CE power Supply
 Yokogawa UT-450 Temperature Controller

Pump March BC-3CP-MD 1/15HP
 3.0 gpm max flow rate
 18 ft max head

NOTE: Test started with TEC at 38°C from Trial 02

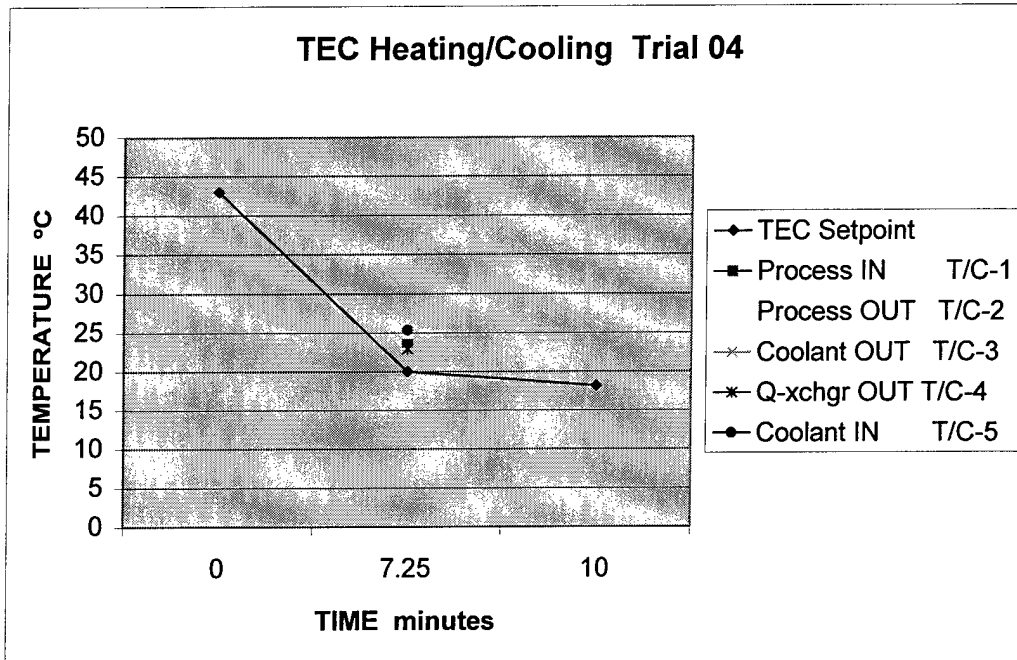

Process Flow Rate = 0.3L/min

Coolant Flow Rate = 1.75gpm

Target = 20.0°C

Ambient = 23.0°C

	TIME minutes		
	0	7.25	10
Process IN T/C-1	43	20	18.14
Process OUT T/C-2		23.78	
Coolant OUT T/C-3		24.94	
Q-xchgr OUT T/C-4		26.06	
Coolant IN T/C-5		22.94	
		25.33	

Cleanstream 1850-B Thermoelectric Heat Exchanger
 Switchback 6600 CE power Supply
 Yokogawa UT-450 Temperature Controller

Pump March BC-3CP-MD 1/15HP
 3.0 gpm max flow rate
 18 ft max head

NOTE: Test started with TEC at 43°C from Trial 03

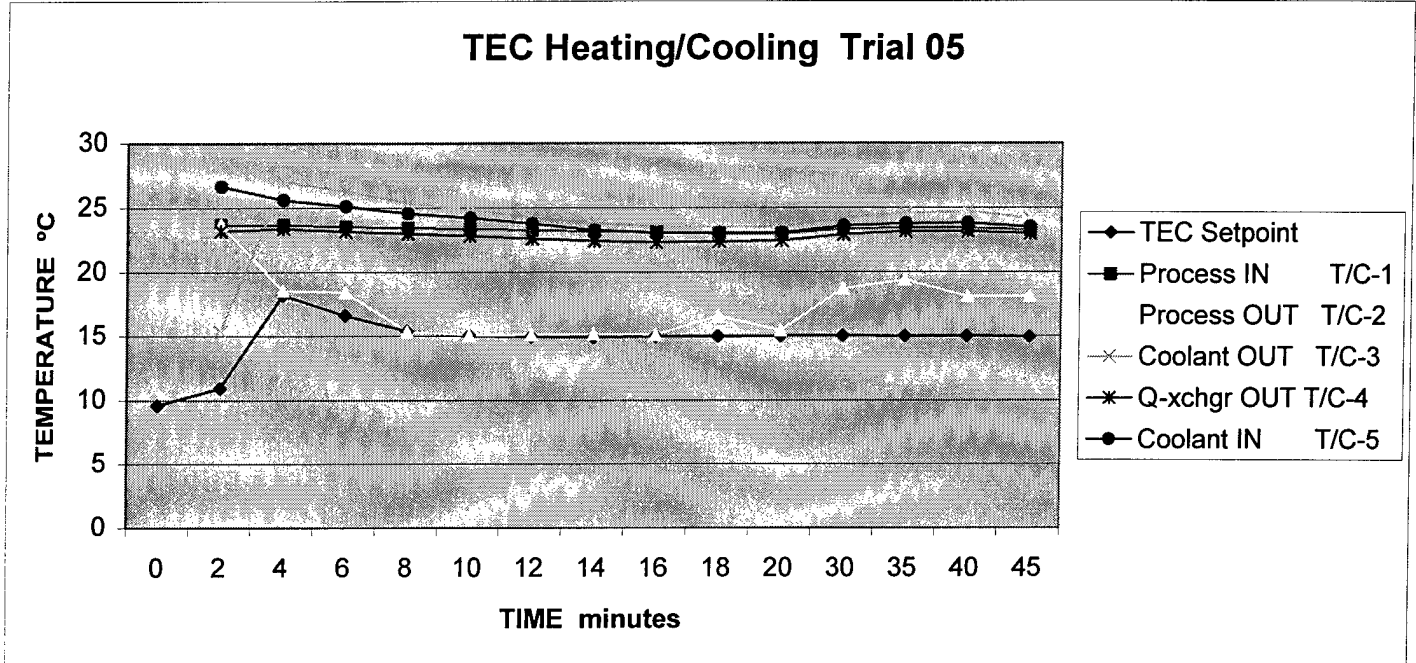

Process Flow Rate = 0.3L/min

Coolant Flow Rate = 1.75gpm

Target = 15.0°C

Ambient = 23.31°C

	TIME minutes														
	0	2	4	6	8	10	12	14	16	18	20	30	35	40	45
Process IN T/C-1	9.61	10.95	18.20	16.62	15.40	15.02	14.96	14.92	14.97	14.98	15.02	15.04	15.01	15.02	14.95
Process OUT T/C-2		23.67	23.67	23.56	23.44	23.39	23.28	23.17	23.11	23.00	23.00	23.39	23.44	23.44	23.27
Coolant OUT T/C-3		23.72	18.56	18.44	15.39	15.06	15.11	15.17	15.11	16.56	15.44	18.72	19.39	18.11	18.11
Q-xchgr OUT T/C-4		15.39	27.06	26.28	25.39	24.83	24.28	23.78	23.56	23.50	23.56	24.22	24.56	24.72	24.17
Q-xchgr IN T/C-4		23.22	23.38	23.17	23.00	22.83	22.61	22.44	22.33	22.39	22.44	22.94	23.17	23.17	23.00
Coolant IN T/C-5		26.67	25.61	25.11	24.56	24.22	23.78	23.28	23.06	23.06	23.06	23.61	23.78	23.83	23.50

Cleanstream 1850-B Thermoelectric Heat Exchanger
 Switchback 6600 CE power Supply
 Yokogawa UT-450 Temperature Controller

Pump March BC-3CP-MD 1/15HP
 3.0 gpm max flow rate
 18 ft max head

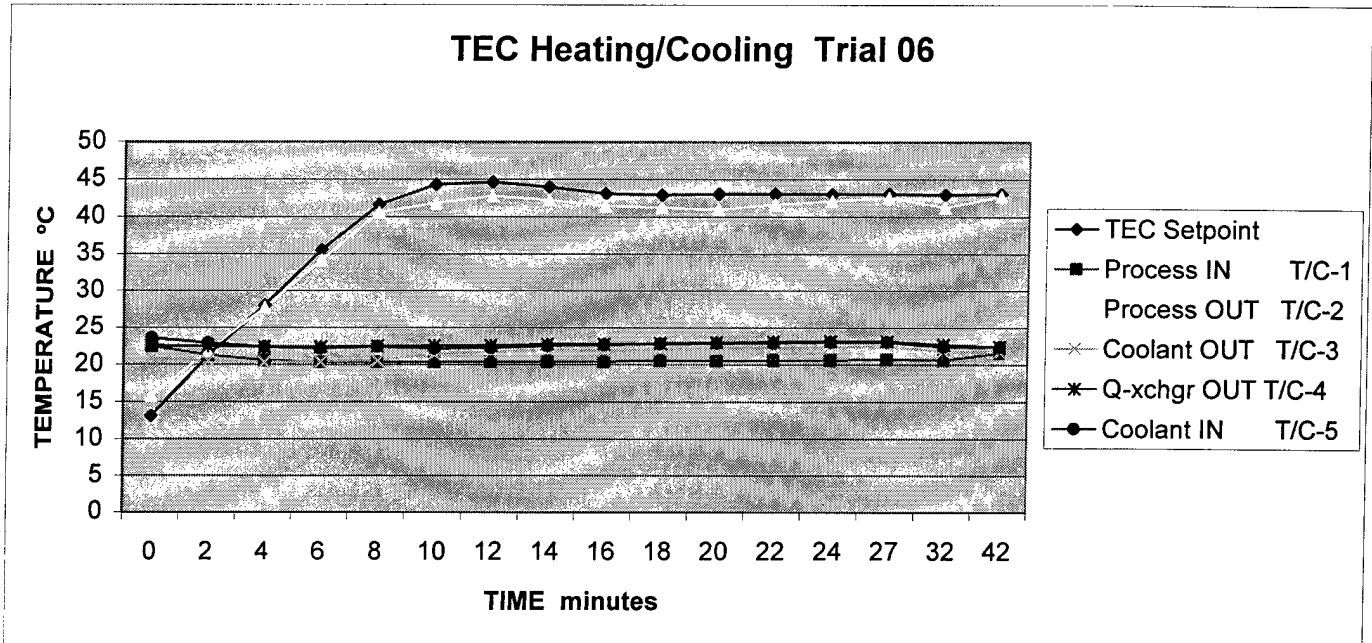

Process Flow Rate = 0.3L/min

Coolant Flow Rate = 1.75gpm

Target = 43°C

Ambient = 23.31°C

	TIME minutes															
	0	2	4	6	8	10	12	14	16	18	20	22	24	27	32	42
Process IN T/C-1	22.50	21.28	20.61	20.33	20.33	20.33	20.39	20.44	20.44	20.61	20.50	20.61	20.61	20.72	20.67	21.56
Process OUT T/C-2	15.83	21.83	27.74	34.17	40.61	41.83	42.78	42.28	41.50	41.22	41.00	41.67	42.11	42.56	41.28	42.72
Coolant OUT T/C-3	20.78	20.56	20.33	20.44	20.61	21.44	21.72	22.06	21.94	22.11	22.22	22.33	22.39	22.50	21.83	21.72
Q-xchgr OUT T/C-4	22.56	22.50	22.39	22.39	22.50	22.56	22.61	22.78	22.78	22.89	23.00	23.11	23.17	23.17	22.72	22.44
Coolant IN T/C-5	23.61	22.94	22.39	22.17	22.44	22.17	22.28	22.56	22.67	22.83	22.89	22.94	23.06	23.06	22.44	22.39

Cleanstream 1850-B Thermoelectric Heat Exchanger

Switchback 6600 CE power Supply

Yokogawa UT-450 Temperature Controller

Pump March BC-3CP-MD 1/15HP

3.0 gpm max flow rate

18 ft max head

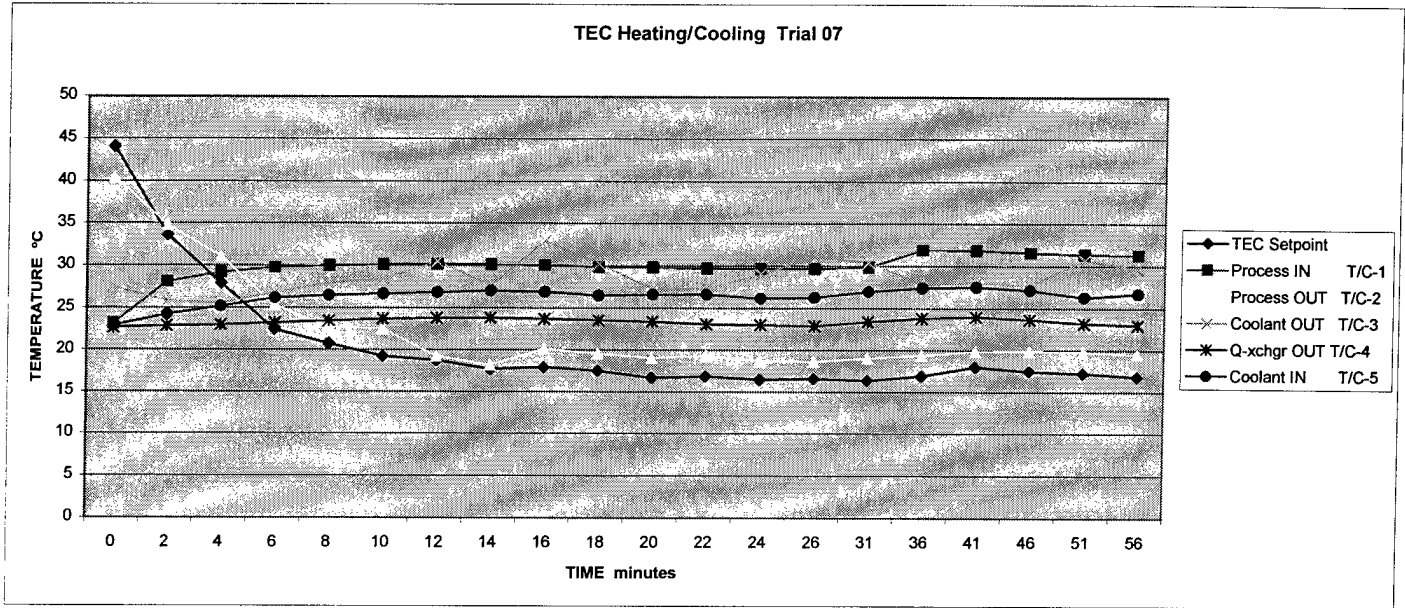

Process Flow Rate = 0.3L/min

Coolant Flow Rate = 1.75gpm

Target = 10°C

Ambient = 23.31°C

	TIME minutes																			
	0	2	4	6	8	10	12	14	16	18	20	22	24	26	31	36	41	46	51	56
TEC Setpoint	44.04	33.64	27.92	22.42	20.75	19.22	18.73	17.71	17.94	17.52	16.69	16.86	16.48	16.57	16.37	16.93	18	17.47	17.23	16.82
Process IN T/C-1	23.17	28.11	29.22	29.78	30	30.11	30.17	30.11	30.06	29.89	29.83	29.72	29.67	29.72	29.89	31.94	31.89	31.61	31.39	31.28
Process OUT T/C-2	40.44	34.78	31.06	25.33	22.72	22.50	19.22	18.22	20.11	19.56	19.06	19.33	18.72	18.61	19.06	19.39	19.89	19.94	19.78	19.50
Coolant OUT T/C-3	27.44	25.83	25.50	26.78	27.94	28.44	30.50	27.67	32.94	30.28	27.22	27.33	29.00	31.06	30.44	27.83	28.06	27.72	30.67	29.68
Q-xchgr OUT T/C-4	22.67	22.83	22.94	23.22	23.44	23.67	23.78	23.83	23.72	23.56	23.39	23.11	23.00	22.89	23.39	23.83	24.00	23.67	23.22	23.00
Coolant IN T/C-5	22.89	24.22	25.17	26.17	26.5	26.67	26.83	27.06	26.94	26.50	26.61	26.63	26.17	26.28	27.00	27.44	27.56	27.17	26.33	26.72

Cleanstream 1850-B Thermoelectric Heat Exchanger

Switchback 6600 CE power Supply

Yokogawa UT-450 Temperature Controller

Pump March BC-3CP-MD 1/15HP

3.0 gpm max flow rate

18 ft max head

TEC Heating/Cooling Trial 08

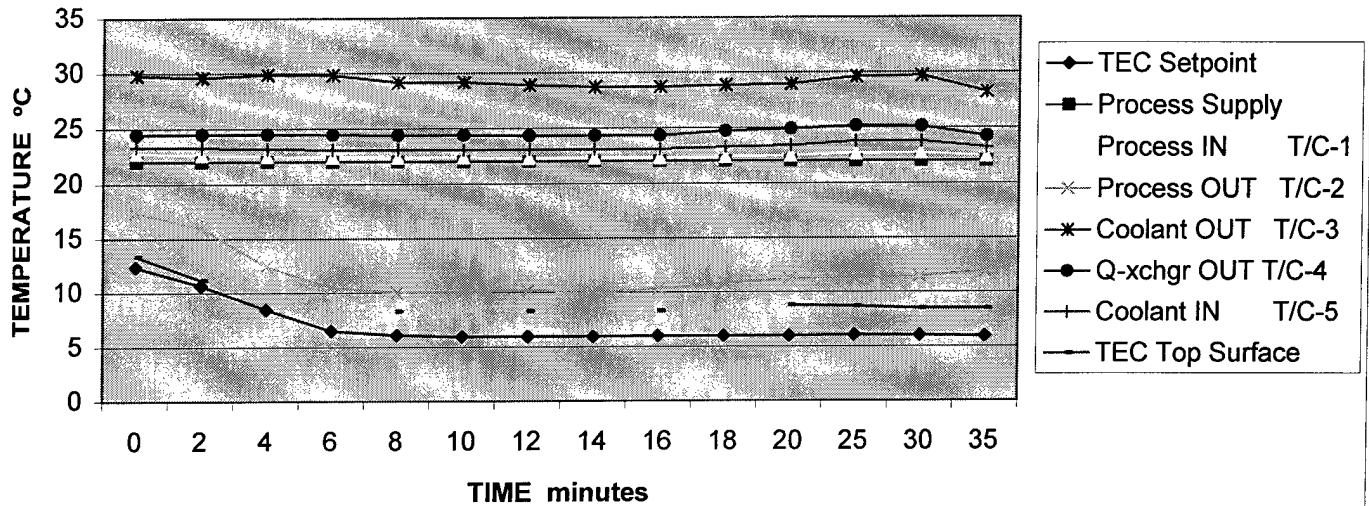

Process Flow Rate = 0.5L/min

Coolant Flow Rate = 3.5gpm

Target = 6°C

Ambient = 19.4°C

	TIME minutes														
	0	2	4	6	8	10	12	14	16	18	20	25	30	35	
TEC Setpoint	12.40	10.68	8.46	6.48	6.09	5.94	5.93	5.94	5.98	5.98	5.99	6.05	6.02	5.94	
Process Supply	22.0	22.0	22.0	22.0	22.0	22.0	22.0	22.0	22.0	22.0	22.0	22.0	22.0	22.0	
Process IN T/C-1	22.78	22.61	22.50	22.44	22.39	22.39	22.33	22.33	22.33	22.39	22.50	22.67	22.72	22.44	
Process OUT T/C-2	17.39	16.00	12.44	10.50	10.00	10.06	10.22	10.00	10.33	10.83	11.22	11.33	11.44	11.94	
Coolant OUT T/C-3	29.78	29.61	29.89	29.83	29.17	29.17	28.89	28.72	28.72	28.83	28.94	29.61	29.72	28.22	
Q-xchgr OUT T/C-4	24.44	24.50	24.50	24.44	24.39	24.39	24.33	24.33	24.33	24.72	24.89	25.17	25.11	24.22	
Coolant IN T/C-5	23.33	23.28	23.17	23.11	23.11	23.06	23.11	23.11	23.11	23.28	23.39	23.78	23.78	23.22	
TEC Top Surface	13.4	11.2			8.3		8.3		8.3		8.8	8.7	8.5	8.5	

Cleanstream 1850-B Thermoelectric Heat Exchanger

Switchback 6600 CE power Supply

Yokogawa UT-450 Temperature Controller

Pump Iwaki Magnet Pump

35.6 gpm max flow rate

39 ft max head

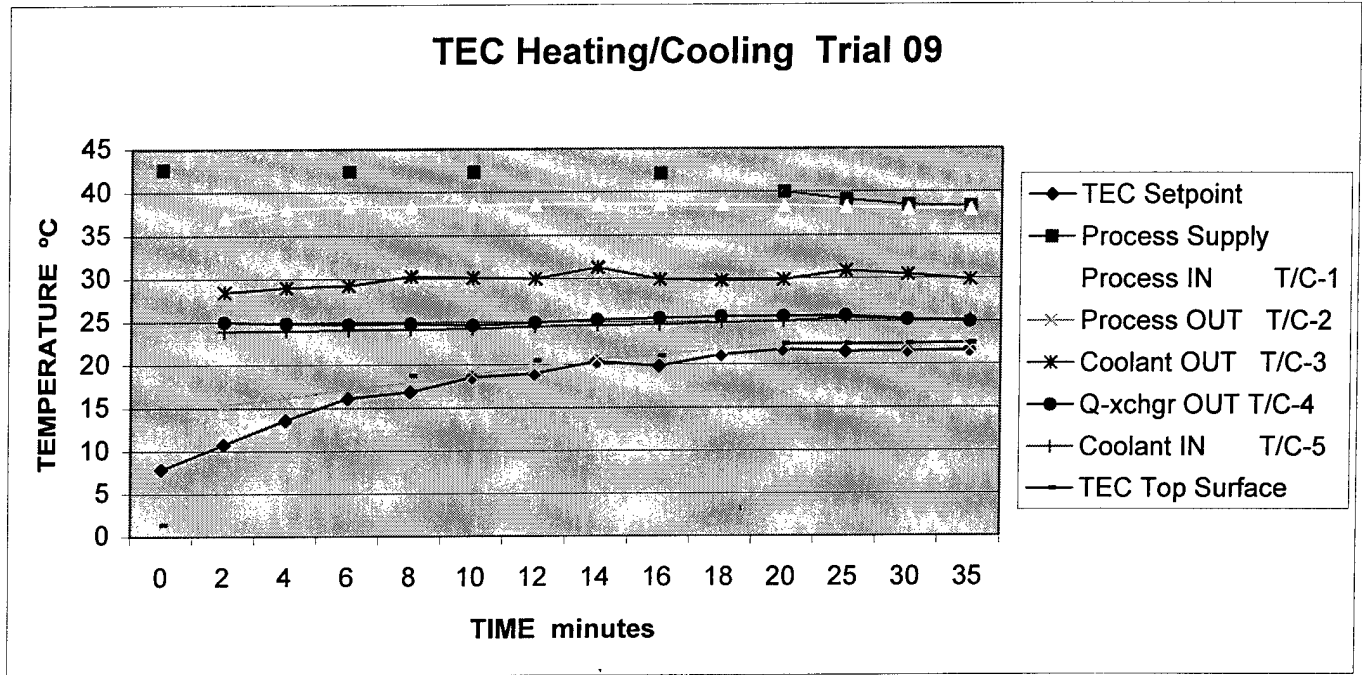

Process Flow Rate = 0.5L/min Coolant Flow Rate = 3.5gpm Target = 6°C Ambient = 22.6°C

	TIME minutes													
	0	2	4	6	8	10	12	14	16	18	20	25	30	35
Process Supply	42.6			42.4		42.3			42.1		40.0	39.1	38.5	38.3
Process IN T/C-1		37.06	38.06	38.39	38.34	38.56	38.56	38.56	38.56	38.50	38.44	38.28	38.00	37.94
Process OUT T/C-2		15.44	16.17	17.22	17.94	19.00	19.67	20.72	21.06	21.83	22.39	22.44	22.06	21.89
Coolant OUT T/C-3		28.44	29.00	29.21	30.28	30.11	30.00	31.28	29.89	29.78	29.83	30.89	30.44	29.87
Q-xchgr OUT T/C-4		25.00	24.83	24.72	24.78	24.61	24.89	25.22	25.39	25.56	25.61	25.67	25.22	24.94
Coolant IN T/C-5		23.89	24	24.06	24.11	24.22	24.44	24.56	24.67	24.89	25	25.39	25.17	25.22
TEC Top Surface	1.4				18.8		20.5		21.0		22.4	22.4	22.4	22.5

Cleanstream 1850-B Thermoelectric Heat Exchanger
 Switchback 6600 CE power Supply
 Yokogawa UT-450 Temperature Controller

Pump Iwaki Magnet Pump
 35.6 gpm max flow rate
 39 ft max head

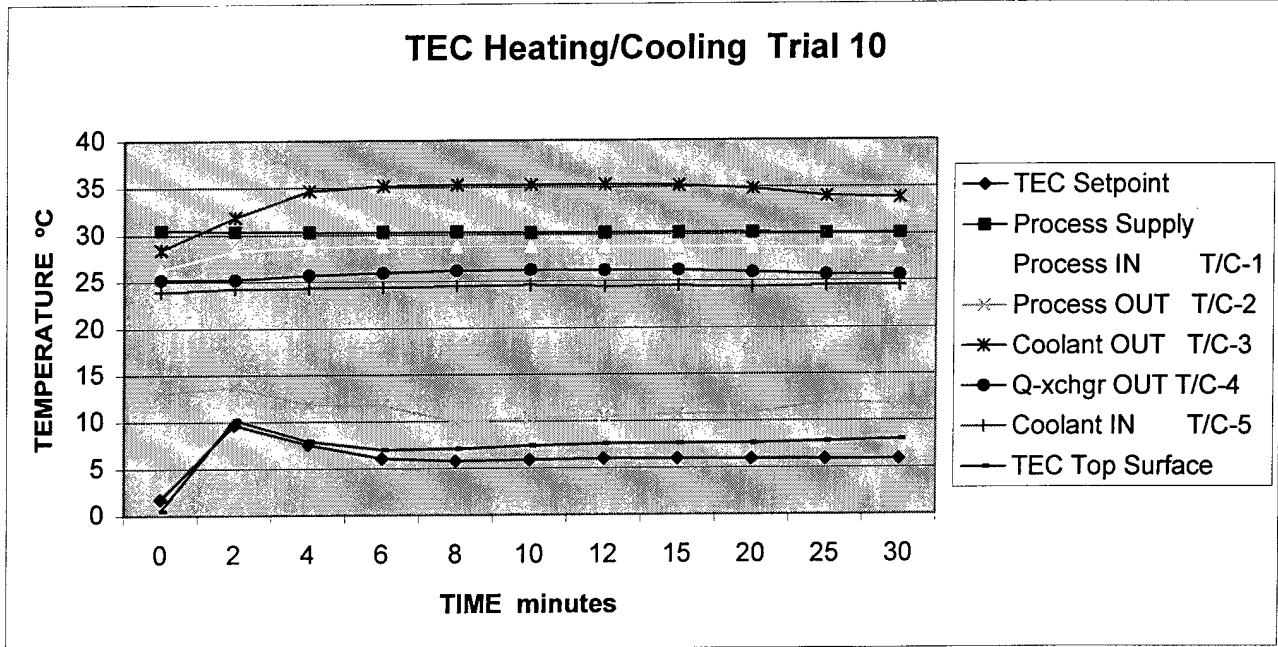

Process Flow Rate = 0.5L/min

Coolant Flow Rate = 3.5gpm

Target = 6°C

Ambient = 19.2°C

	TIME minutes											
	0	2	4	6	8	10	12	15	20	25	30	
Process Supply	1.75	9.66	7.54	6.08	5.78	5.91	6.02	5.99	5.95	5.93	5.92	
Process IN T/C-1	30.5	30.4	30.3	30.3	30.3	30.2	30.2	30.2	30.2	30.1	30.1	
Process OUT T/C-2	26.33	28.28	28.72	28.78	28.72	28.72	28.72	28.67	28.61	28.5	28.44	
Coolant OUT T/C-3	13.00	13.72	11.83	11.72	9.94	10.33	10.50	10.72	10.83	11.94	11.78	
Q-xchgr OUT T/C-4	28.44	31.89	34.67	35.17	35.28	35.28	35.33	35.22	34.83	34.06	33.89	
Q-xchgr OUT T/C-4	25.22	25.22	25.67	25.94	26.17	26.22	26.17	26.17	25.94	25.67	25.61	
Coolant IN T/C-5	23.94	24.28	24.33	24.39	24.50	24.61	24.44	24.50	24.33	24.50	24.50	
TEC Top Surface	0.5	10.2	7.9	7.0	7.1	7.4	7.6	7.6	7.6	7.8	8.0	

Cleanstream 1850-B Thermoelectric Heat Exchanger

Switchback 6600 CE power Supply

Yokogawa UT-450 Temperature Controller

Pump Iwaki Magnet Pump

35.6 gpm max flow rate

39 ft max head

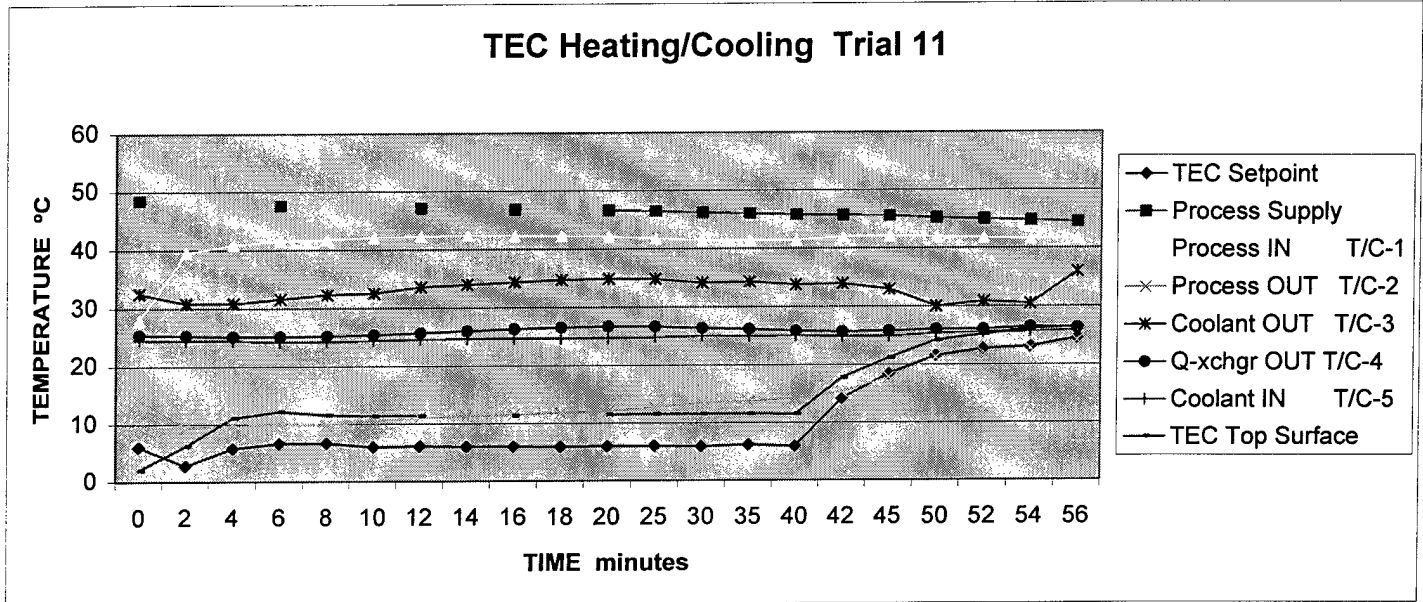

Process Flow Rate = 0.3L/min Coolant Flow Rate = 3.5gpm Target = 6°C Ambient = 19.6°C
 Process Flow Rate = 0.5L/min @ 40 min.

	TIME minutes																				
	0	2	4	6	8	10	12	14	16	18	20	25	30	35	40	42	45	50	52	54	56
Process Supply	6.02	2.75	5.80	6.62	6.66	6.00	6.13	6.00	5.99	5.97	6.01	6.05	5.90	6.20	5.91	14.24	18.45	21.55	22.74	23.10	24.62
Process IN T/C-1	48.5			47.6			47.1		46.8		46.6	46.5	46.2	46.0	45.8	45.7	45.6	45.2	45.0	44.80	44.50
Process OUT T/C-2	27.94	39.50	40.89	41.56	41.78	42.11	42.28	42.39	42.33	42.22	42.11	41.78	41.44	41.44	41.44	42.00	42.11	41.89	41.78	41.61	41.61
Coolant OUT T/C-3	14.22	9.39	9.78	10.00	9.89	10.50	11.06	11.28	11.50	11.83	12.06	12.72	13.50	13.72	14.28	15.33	17.83	21.33	22.11	22.78	24.22
Coolant OUT T/C-3	32.56	30.83	30.83	31.61	32.33	32.61	33.61	34.00	34.39	34.78	34.89	34.83	34.17	34.33	33.83	33.94	33.00	30.06	30.89	30.50	36.00
Q-xchgr OUT T/C-4	25.44	25.33	25.17	25.17	25.22	25.39	25.72	26.06	26.33	26.61	26.72	26.67	26.39	26.22	25.89	25.72	25.83	26.11	26.11	26.50	26.33
Coolant IN T/C-5	24.56	24.44	24.48	24.22	24.28	24.44	24.61	24.67	24.72	24.72	24.78	24.83	25.06	25.00	25.06	24.89	24.89	25.39	25.56	25.72	25.94
TEC Top Surface	2.0	6.2	11.1	12.2	11.6	11.4	11.4		11.4		11.5	11.6	11.6	11.6	11.5	17.8	21.2	24.2	25.2	26.20	26.50

Cleanstream 1850-B Thermoelectric Heat Exchanger
 Switchback 6600 CE power Supply
 Yokogawa UT-450 Temperature Controller

Pump Iwaki Magnet Pump
 35.6 gpm max flow rate
 39 ft max head

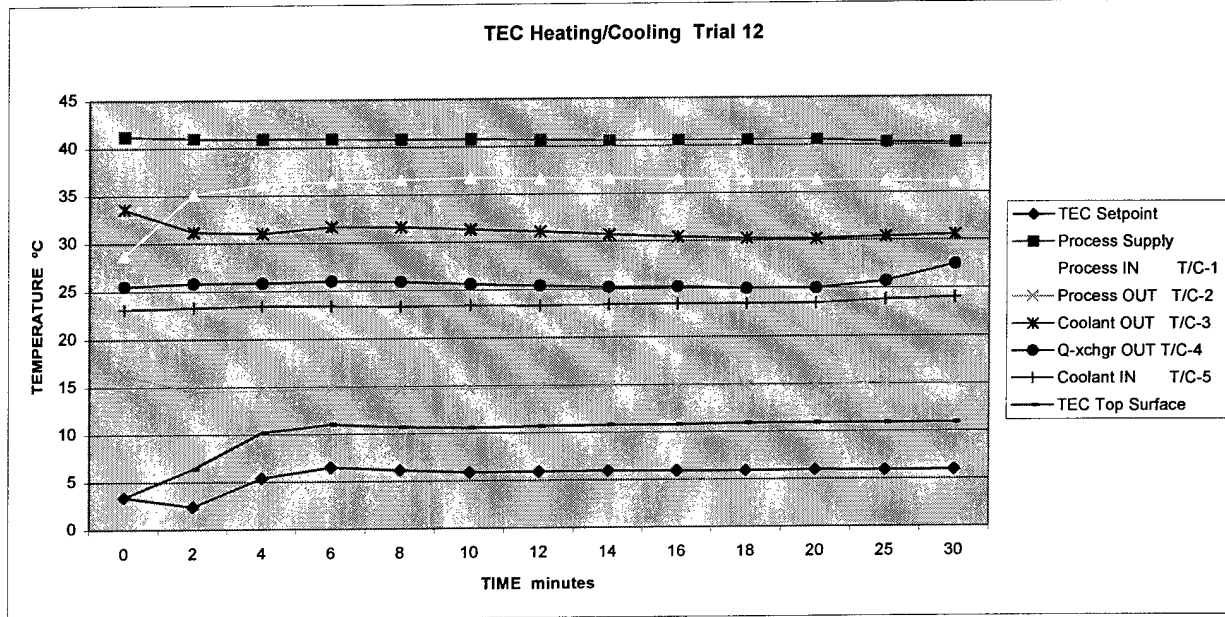

Process Flow Rate = 0.3L/min

Coolant Flow Rate = 3.5gpm

Target = 6°C

Ambient =18.0°C

	TIME minutes												
	0	2	4	6	8	10	12	14	16	18	20	25	30
Process Supply	41.2	41.0	40.9	40.9	40.8	40.8	40.7	40.6	40.6	40.6	40.6	40.3	40.2
Process IN T/C-1	28.78	35.11	36.11	36.39	36.56	36.72	36.61	36.61	36.44	36.39	36.28	36.22	36.06
Process OUT T/C-2	16.22	14.5	14.56	14.78	14.67	14.67	14.72	14.78	14.78	14.78	14.78	15.17	15.22
Coolant OUT T/C-3	33.56	31.17	31.00	31.67	31.61	31.33	31.06	30.73	30.44	30.22	30.17	30.39	30.56
Q-xchgr OUT T/C-4	25.50	25.83	25.83	26.00	25.89	25.61	25.39	25.22	25.22	25.00	25.00	25.72	27.44
Coolant IN T/C-5	23.11	23.28	23.44	23.39	23.33	23.39	23.33	23.39	23.44	23.39	23.44	23.78	24.00
TEC Top Surface	3.4	6.4	10.2	11.0	10.7	10.6	10.7	10.8	10.8	10.9	10.9	10.9	10.9

Cleanstream 1850-B Thermoelectric Heat Exchanger

Switchback 6600 CE power Supply

Yokogawa UT-450 Temperature Controller

Pump Iwaki Magnet Pump

35.6 gpm max flow rate

39 ft max head

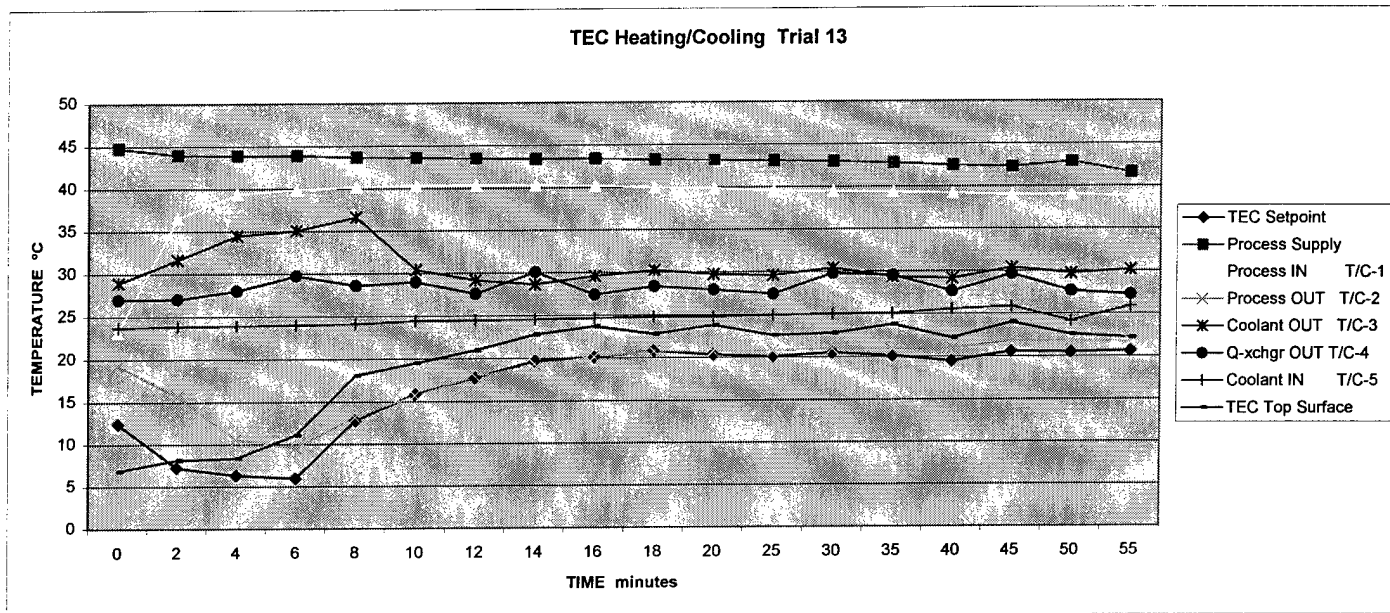

Process Flow Rate = 0.4L/min

Coolant Flow Rate = 3.5gpm

Target = 6°C

Ambient = 20.9°C

	TIME minutes																	
	0	2	4	6	8	10	12	14	16	18	20	25	30	35	40	45	50	55
Process Supply	44.8	44.0	43.9	43.9	43.7	43.6	43.5	43.4	43.4	43.3	43.2	43.1	43.0	42.8	42.5	42.3	42.9	41.6
Process IN T/C-1	23.17	36.61	39.39	39.89	40.22	40.33	40.33	40.33	40.22	40.00	39.89	39.50	39.50	39.33	39.22	39.00	39.06	38.78
Process OUT T/C-2	19.28	15.72	10.61	9.61	13.22	15.72	17.89	19.28	20.17	20.78	20.78	20.78	21.00	20.89	21.00	21.83	21.78	21.72
Coolant OUT T/C-3	28.94	31.67	34.5	35.11	36.67	30.44	29.17	28.67	29.61	30.28	29.78	29.61	30.44	29.39	29.17	30.44	29.78	30.17
Q-xchgr OUT T/C-4	27	27.06	28.04	29.78	28.61	29.00	27.610	30.11	27.44	28.39	27.94	27.44	29.83	29.56	27.67	29.67	27.67	27.28
Coolant IN T/C-5	23.72	23.89	23.94	24.00	24.11	24.44	24.50	24.56	24.67	24.78	24.78	24.94	25.06	25.11	25.56	25.89	24.17	25.89
TEC Top Surface	6.9	8.2	8.4	11.1	18.1	19.5	21.0	22.8	23.7	22.8	23.8	22.6	22.8	23.8	22.2	24.0	22.6	22.2

Cleanstream 1850-B Thermoelectric Heat Exchanger

Switchback 6600 CE power Supply

Yokogawa UT-450 Temperature Controller

Pump Iwaki Magnet Pump

35.6 gpm max flow rate

39 ft max head

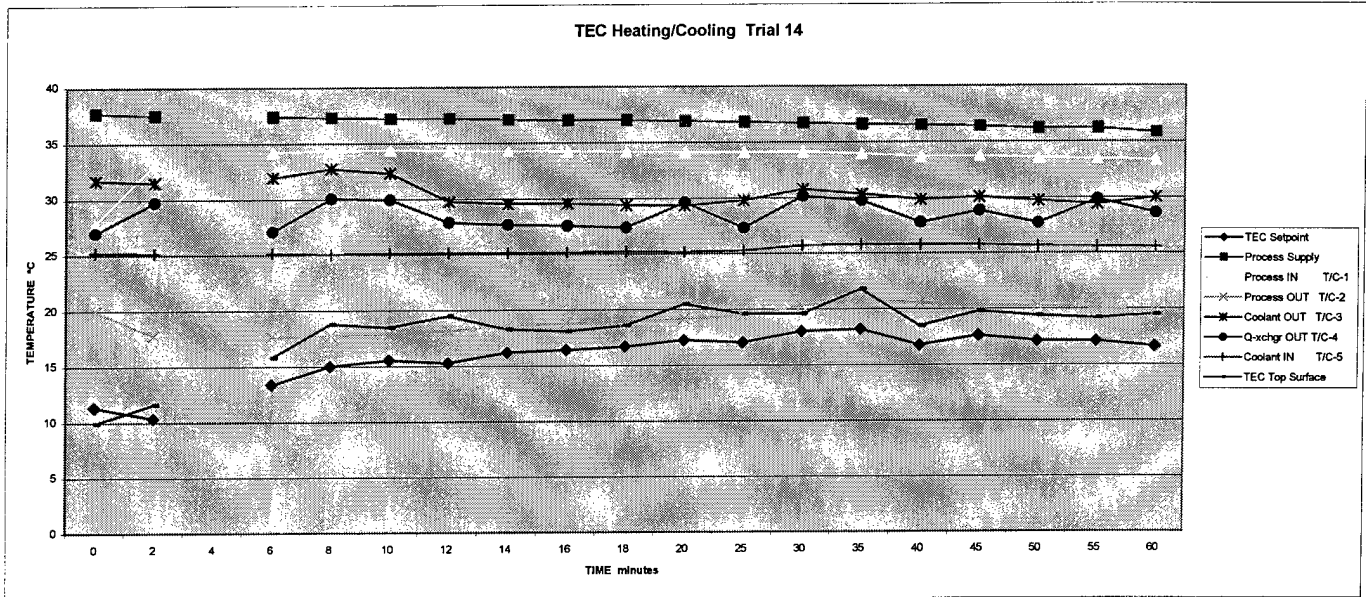

Process Flow Rate = 0.4L/min

Coolant Flow Rate = 3.5gpm

Target = 6°C

Ambient = 19.5°C

	TIME minutes																		
	0	2	4	6	8	10	12	14	16	18	20	25	30	35	40	45	50	55	60
Process Supply	11.34	10.36		13.36	15.02	15.54	15.28	16.22	16.41	16.70	17.26	17.04	18.04	18.2	16.79	17.64	17.16	17.11	16.64
Process IN T/C-1	37.7	37.5		37.4	37.3	37.2	37.2	37.1	37.0	37.0	36.9	36.8	36.7	36.6	36.5	36.4	36.2	36.2	35.8
Process OUT T/C-2	27.78	33.17		34.22	34.33	34.39	34.33	34.28	34.22	34.17	34.11	34.11	34.11	33.94	33.67	33.72	33.56	33.44	33.33
Coolant OUT T/C-3	19.94	17.78		17.61	17.78	17.89	18.17	18.61	18.78	18.94	19.17	19.44	20.33	20.83	20.56	20.33	20.28	20.06	19.78
Q-exchgr OUT T/C-4	31.72	31.50		31.94	32.72	32.30	29.78	29.56	29.56	29.39	29.33	29.80	30.78	30.33	29.83	30.06	29.72	29.39	30.00
Coolant IN T/C-5	27.00	29.72		27.11	30.06	29.94	27.89	27.67	27.56	27.39	29.61	27.33	30.17	29.72	27.78	28.83	27.72	29.83	28.61
Coolant IN T/C-5	25.22	25.17		25.17	25.06	25.17	25.17	25.17	25.17	25.22	25.17	25.28	25.72	25.83	25.78	25.78	25.67	25.61	25.56
TEC Top Surface	9.9	11.6		15.8	18.8	18.5	19.5	18.3	18.1	18.6	20.5	19.6	19.6	21.8	18.5	19.8	19.4	19.2	19.5

Cleanstream 1850-B Thermoelectric Heat Exchanger

Switchback 6600 CE power Supply

Yokogawa UT-450 Temperature Controller

Pump Iwaki Magnet Pump

35.6 gpm max flow rate

39 ft max head

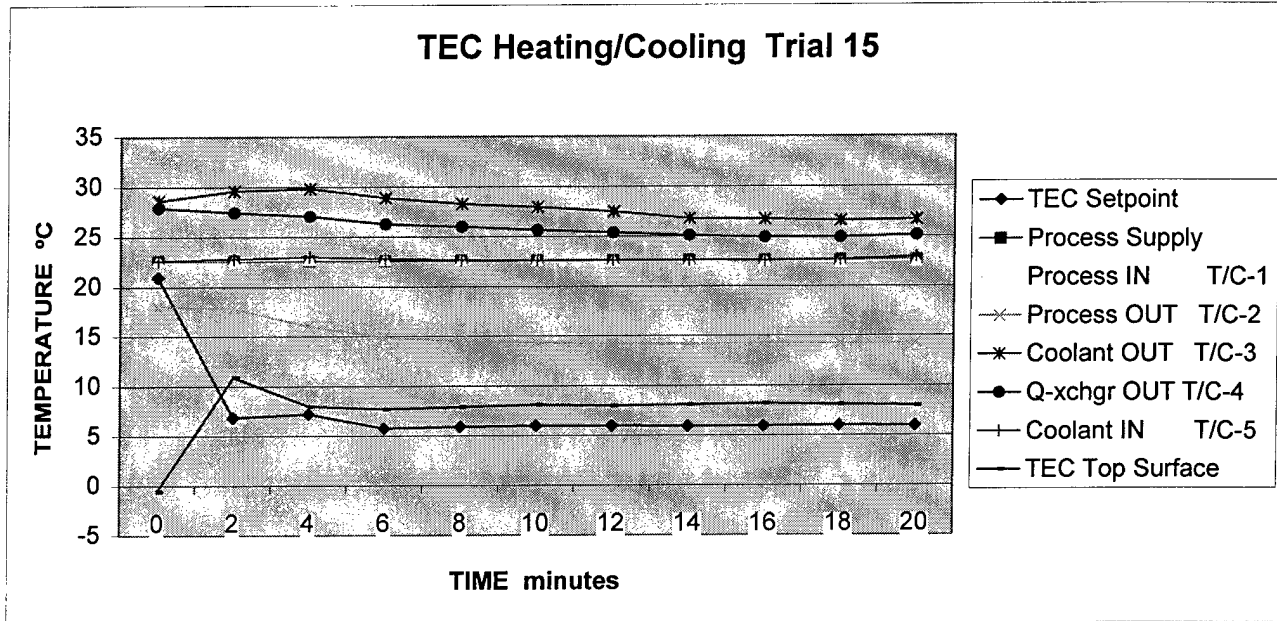

Process Flow Rate = 0.3L/min

Coolant Flow Rate = 3.5gpm

Target = 6°C

Ambient = 19.0°C

	TIME minutes										
	0	2	4	6	8	10	12	14	16	18	20
Process Supply	22.6	22.6	22.6	22.6	22.6	22.6	22.6	22.6	22.6	22.6	22.6
Process IN T/C-1	22.67	22.67	22.78	22.72	22.67	22.67	22.56	22.50	22.56	22.44	22.50
Process OUT T/C-2	18.06	17.83	16.00	14.89	14.50	14.33	14.22	14.17	14.28	14.22	14.28
Coolant OUT T/C-3	28.61	29.61	29.83	28.89	28.28	27.94	27.50	26.78	26.72	26.56	26.67
Q-xchgr OUT T/C-4	27.89	27.44	27.06	26.28	26.00	25.67	25.39	25.11	24.89	24.89	25.11
Coolant IN T/C-5	22.61	22.78	23	22.78	22.67	22.61	22.61	22.61	22.56	22.67	22.94
TEC Top Surface	-0.6	10.9	8	7.7	7.9	8.1	8	8.1	8.2	8.1	8

Cleanstream 1850-B Thermoelectric Heat Exchanger

Switchback 6600 CE power Supply

Yokogawa UT-450 Temperature Controller

Pump Iwaki Magnet Pump

35.6 gpm max flow rate

39 ft max head

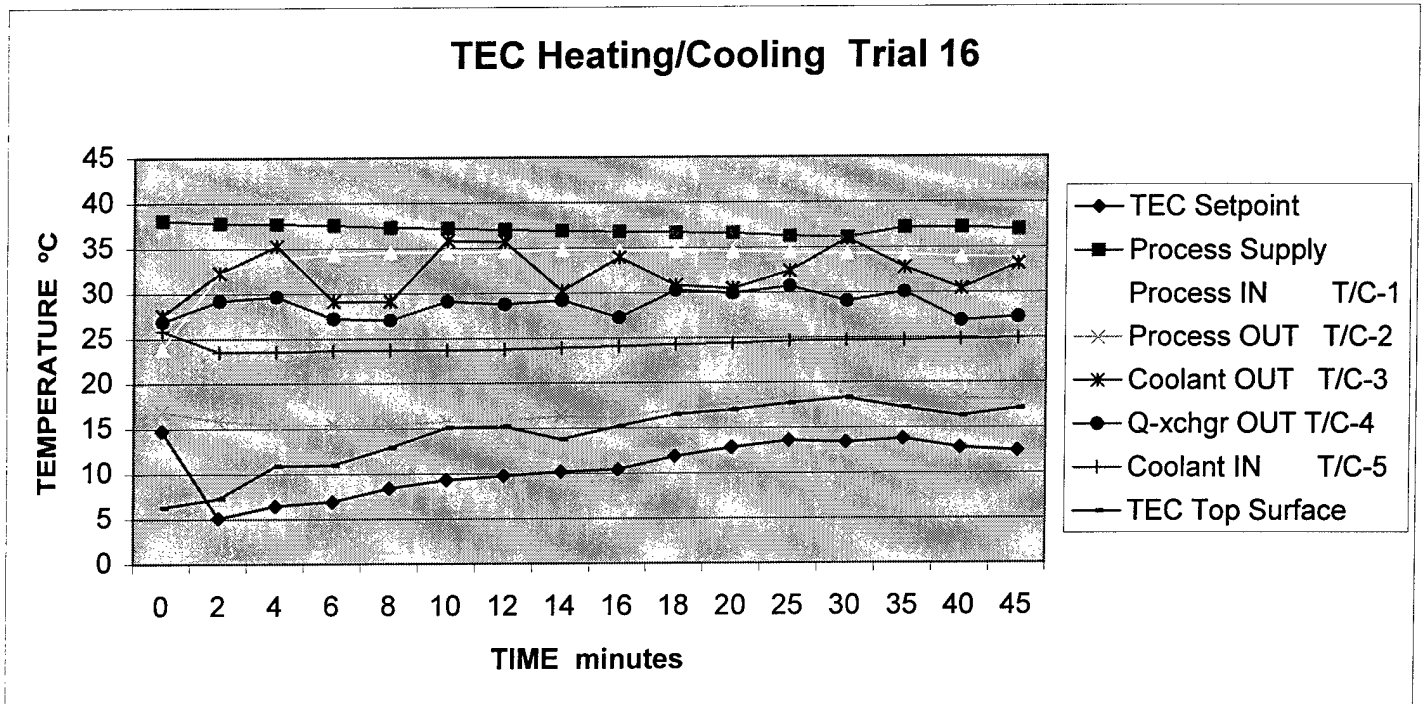

Process Flow Rate = 0.3L/min

Coolant Flow Rate = 3.5gpm

Target = 6°C

Ambient = 19.5°C

	TIME minutes															
	0	2	4	6	8	10	12	14	16	18	20	25	30	35	40	45
Process Supply	14.76	5.10	6.51	6.94	8.43	9.31	9.76	10.20	10.47	11.89	12.84	13.58	13.41	13.78	12.81	12.47
Process IN T/C-1	38.1	37.8	37.7	37.6	37.3	37.2	37.0	36.9	36.8	36.7	36.6	36.3	36.1	37.2	37.2	37.0
Process OUT T/C-2	23.89	32.28	33.89	34.33	34.56	34.50	34.61	34.78	34.72	34.67	34.56	34.44	34.33	34.22	33.94	33.89
Coolant OUT T/C-3	16.83	15.83	15.39	15.39	15.39	15.72	15.89	16.33	16.11	17.11	17.67	18.39	18.33	18.50	18.17	18.11
Q-xchgr OUT T/C-4	27.61	32.28	35.28	29.17	29.11	35.83	35.67	30.22	33.94	30.83	30.50	32.39	36.00	32.78	30.44	33.17
Coolant IN T/C-5	26.89	29.22	29.67	27.22	27.06	29.11	28.78	29.22	27.28	30.28	29.94	30.72	29.06	30.06	26.89	27.28
TEC Top Surface	25.89	23.50	23.56	23.67	23.72	23.72	23.78	23.94	24.11	24.28	24.39	24.61	24.72	24.72	24.83	24.94
TEC Top Surface	6.3	7.3	10.9	11.0	12.9	15.1	15.2	13.8	15.2	16.5	17.0	17.7	18.3	17.2	16.3	17.1

Cleanstream 1850-B Thermoelectric Heat Exchanger

Switchback 6600 CE power Supply

Yokogawa UT-450 Temperature Controller

Pump Iwaki Magnet Pump

35.6 gpm max flow rate

39 ft max head

TEC Heating/Cooling Trial 17

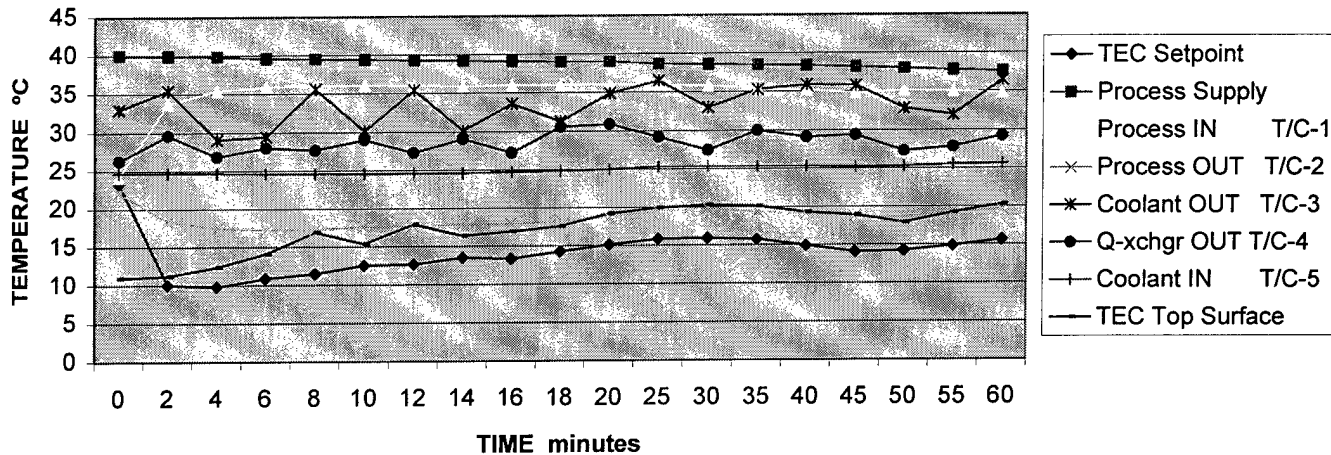

Process Flow Rate = 0.3L/min

Coolant Flow Rate = 3.5gpm

Target = 6°C

Ambient = 18.5°C

	TIME minutes																			
	0	2	4	6	8	10	12	14	16	18	20	25	30	35	40	45	50	55	60	
Process Supply	23.36	10.06	9.80	10.90	11.51	12.55	12.70	13.54	13.38	14.28	15.14	15.86	15.94	15.78	14.94	14.12	14.24	14.89	15.61	
Process IN T/C-1	40.0	39.9	39.8	39.6	39.5	39.4	39.3	39.2	39.1	39.0	39.0	38.7	38.6	38.5	38.4	38.2	38.0	37.8	37.6	
Process OUT T/C-2	24.17	33.72	35.39	35.89	36.06	36.06	36.00	35.89	36.00	36.00	36.06	35.94	35.83	35.39	35.22	34.83	35.11	35.00	34.78	
Coolant OUT T/C-3	22.11	18.39	17.44	17.28	17.28	17.61	17.67	17.89	17.89	18.28	18.72	19.44	19.89	19.28	19.06	18.72	18.61	19.22	19.61	
Coolant IN T/C-5	33.00	35.44	29.06	29.44	35.61	30.11	35.44	30.11	33.61	31.28	34.89	36.50	33.00	35.30	35.89	35.83	32.83	32.00	36.50	
Q-xchgr OUT T/C-4	26.28	29.61	26.83	28.00	27.67	29.00	27.28	29.06	27.22	30.56	30.89	29.17	27.44	30.00	29.11	29.39	27.28	27.83	29.22	
TEC Top Surface	24.67	24.67	24.67	24.61	24.61	24.56	24.61	24.61	24.72	24.83	25.00	25.33	25.33	25.33	25.33	25.22	25.28	25.50	25.61	
TEC Top Surface	11.0	11.2	12.4	14.1	16.9	15.4	17.9	16.4	16.9	17.6	19.2	19.9	20.3	20.1	19.3	18.9	17.9	19.2	20.3	

Cleanstream 1850-B Thermoelectric Heat Exchanger

Switchback 6600 CE power Supply

Yokogawa UT-450 Temperature Controller

Pump Iwaki Magnet Pump

35.6 gpm max flow rate

39 ft max head

TEC Heating/Cooling Trial 18

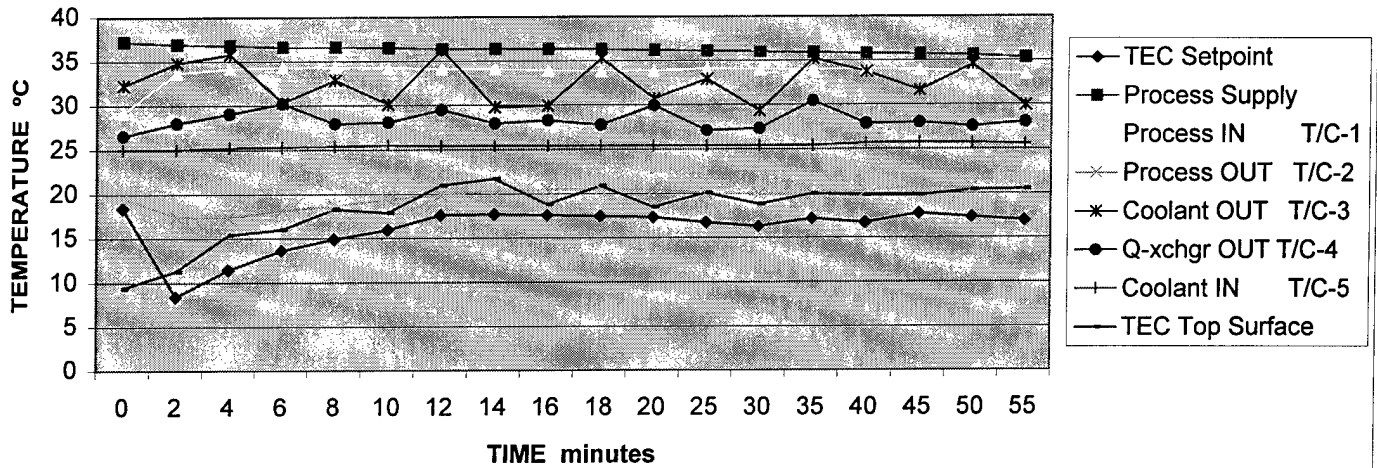

Process Flow Rate = 0.4L/min

Coolant Flow Rate = 3.5gpm

Target = 6°C

Ambient = 19.0°C

	TIME minutes																	
	0	2	4	6	8	10	12	14	16	18	20	25	30	35	40	45	50	55
Process Supply	18.41	8.42	11.44	13.64	14.92	15.96	17.64	17.69	17.62	17.46	17.34	16.76	16.29	17.18	16.71	17.76	17.36	16.98
Process IN T/C-1	37.2	36.9	36.8	36.6	36.6	36.5	36.4	36.4	36.3	36.3	36.2	36.1	36.0	35.9	35.8	35.7	35.6	35.3
Process OUT T/C-2	29.17	33.67	34.17	34.33	34.33	34.28	34.11	34.06	33.89	33.83	33.83	34.11	34.00	34.00	34.06	33.94	33.72	33.44
Coolant OUT T/C-3	19.61	17.44	17.39	18.17	18.67	19.39	19.94	20.33	20.50	20.50	20.44	20.06	19.89	19.94	20.28	20.78	20.61	20.39
Coolant OUT T/C-3	32.28	34.78	35.78	30.33	32.83	30.11	36.28	29.78	29.94	35.28	30.73	32.94	29.33	35.22	33.72	31.61	34.56	29.94
Q-xchgr OUT T/C-4	26.56	28.00	29.06	30.22	27.94	28.10	29.500	27.94	28.28	27.78	29.94	27.11	27.33	30.44	27.89	28.00	27.56	28.06
Coolant IN T/C-5	25.06	25.06	25.22	25.33	25.39	25.50	25.44	25.39	25.39	25.39	25.39	25.39	25.39	25.44	25.67	25.78	25.72	25.61
TEC Top Surface	9.4	11.3	15.4	16.0	18.3	17.9	21.0	21.7	18.8	20.9	18.5	20.1	18.8	20.0	19.8	19.8	20.4	20.5

Cleanstream 1850-B Thermoelectric Heat Exchanger

Switchback 6600 CE power Supply

Yokogawa UT-450 Temperature Controller

Pump Iwaki Magnet Pump

35.6 gpm max flow rate

39 ft max head

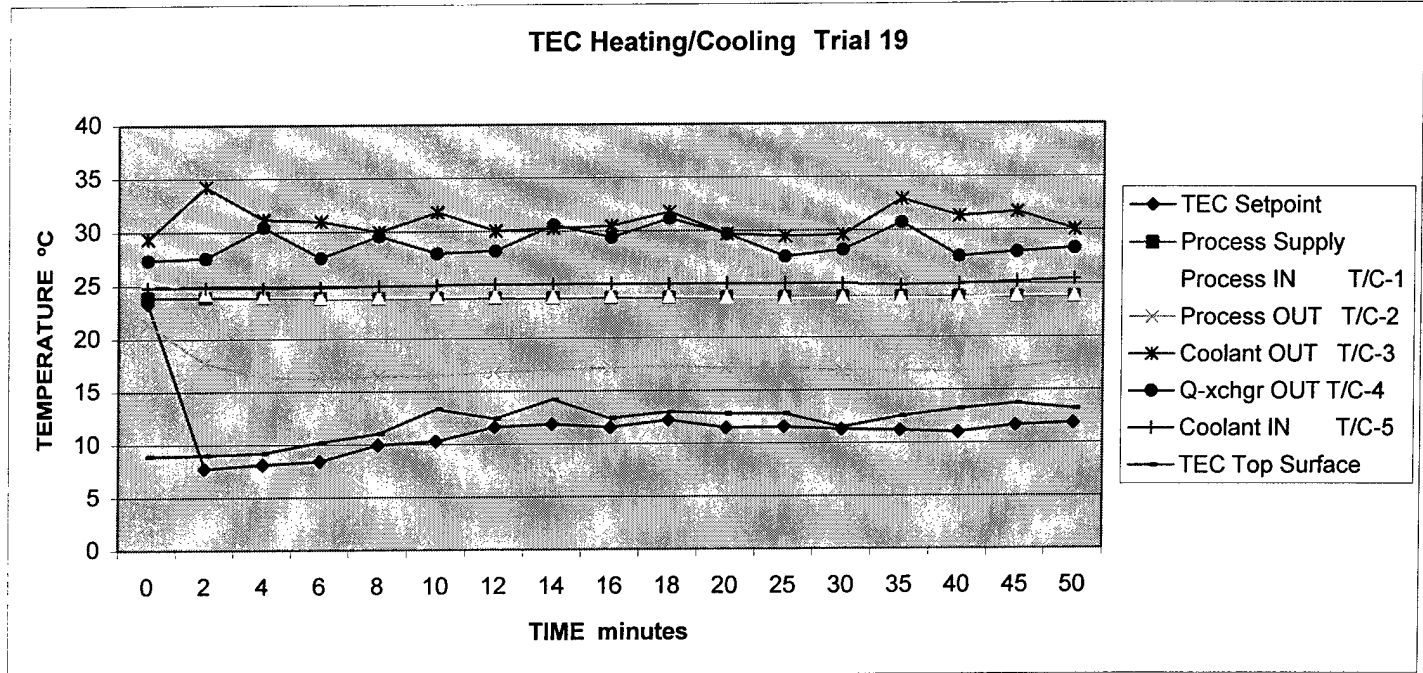

Process Flow Rate = 0.4L/min

Coolant Flow Rate = 3.5gpm

Target = 6°C

Ambient = 20.0°C

	TIME minutes																
	0	2	4	6	8	10	12	14	16	18	20	25	30	35	40	45	50
Process Supply	23.36	7.75	8.12	8.42	9.95	10.28	11.61	11.86	11.55	12.22	11.47	11.52	11.28	11.18	11.00	11.64	11.85
Process IN T/C-1	25.61	24.28	24.00	23.89	23.89	23.89	23.94	23.89	23.94	23.89	23.78	23.72	23.72	23.72	23.67	23.89	23.89
Process OUT T/C-2	21.39	17.67	16.33	16.17	16.39	16.50	16.78	17.00	17.17	17.28	17.11	17.06	16.89	16.78	16.72	17.06	17.67
Coolant OUT T/C-3	29.39	34.22	31.17	31.00	30.00	31.83	30.06	30.28	30.50	31.78	29.72	29.5	29.61	32.94	31.33	31.72	30.06
Q-xchgr OUT T/C-4	27.39	27.61	30.44	27.61	29.61	28.00	28.22	30.61	29.44	31.17	29.72	27.61	28.22	30.72	27.56	28.00	28.33
Coolant IN T/C-5	24.83	24.83	24.78	24.83	24.94	25.00	25.11	25.11	25.11	25.06	25.11	25.11	25.06	24.89	25.00	25.20	25.44
TEC Top Surface	8.9	9.0	9.2	10.2	11.0	13.3	12.4	14.2	12.4	13.0	12.8	12.8	11.5	12.5	13.2	13.7	13.2

Cleanstream 1850-B Thermoelectric Heat Exchanger

Switchback 6600 CE power Supply

Yokogawa UT-450 Temperature Controller

Pump Iwaki Magnet Pump

35.6 gpm max flow rate

39 ft max head

TEC Heating/Cooling Trial 20

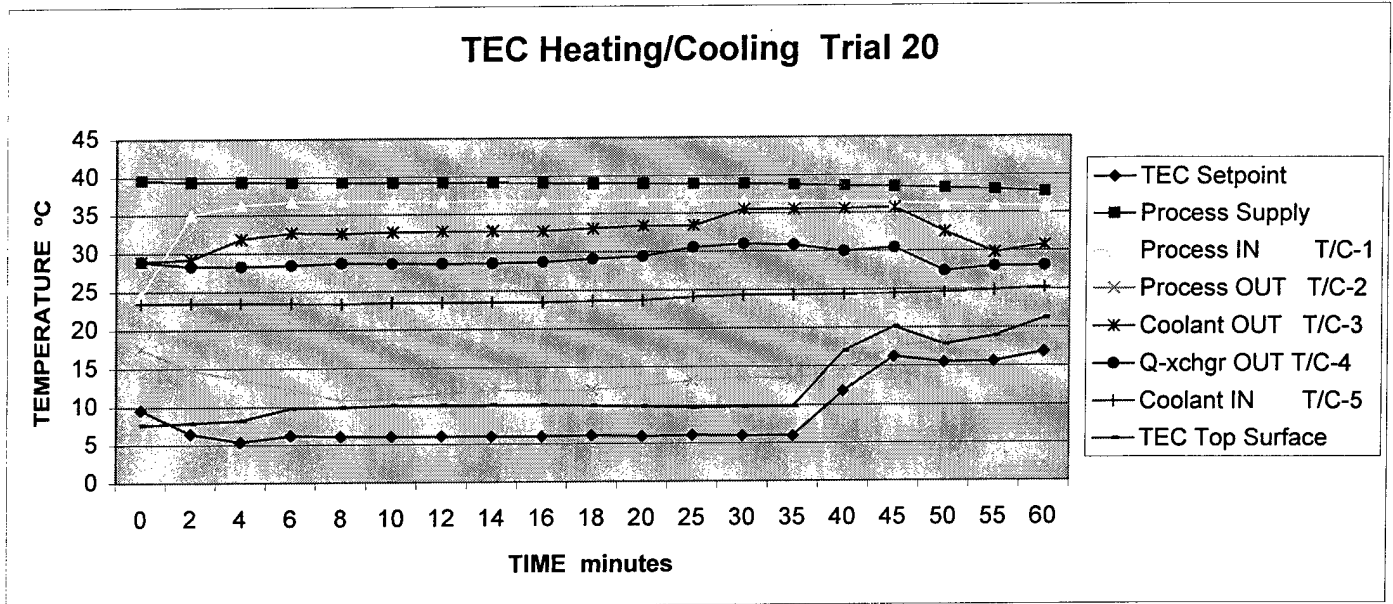

Process Flow Rate = 0.4L/min

Coolant Flow Rate = 3.5gpm

Target = 6°C

Ambient = 20.4°C

	TIME minutes																		
	0	2	4	6	8	10	12	14	16	18	20	25	30	35	40	45	50	55	60
Process Supply	39.6	39.4	39.4	39.3	39.3	39.2	39.2	39.2	39.1	39.0	39.0	38.9	38.9	38.8	38.6	38.5	38.3	38.1	37.8
Process IN T/C-1	24.50	35.00	36.33	36.72	36.89	36.78	36.72	36.78	36.72	36.72	36.78	36.72	36.72	36.61	36.50	36.39	36.11	36.00	35.83
Process OUT T/C-2	17.56	14.78	13.61	12.28	10.83	11.00	11.67	12.00	12.06	12.06	12.56	13.22	13.61	13.39	14.61	17.50	18.28	18.72	19.39
Coolant OUT T/C-3	28.94	29.22	31.89	32.67	32.56	32.72	32.78	32.78	32.78	33.11	33.44	33.44	35.56	35.56	35.61	35.72	32.50	29.78	30.78
Q-xchgr OUT T/C-4	28.89	28.33	28.28	28.44	28.67	28.61	28.56	28.61	28.72	29.11	29.44	30.56	31.00	30.83	30.00	30.44	27.39	28.00	28.06
Coolant IN T/C-5	23.44	23.50	23.50	23.44	23.39	23.5	23.50	23.50	23.50	23.61	23.72	24.11	24.33	24.33	24.39	24.44	24.61	24.89	25.22
TEC Top Surface	7.6	7.9	8.2	9.8	9.9	10.1	10.1	10.1	10.1	10.0	9.9	9.7	9.8	9.8	17.0	20.1	17.8	18.9	21.2

Cleanstream 1850-B Thermoelectric Heat Exchanger

Switchback 6600 CE power Supply

Yokogawa UT-450 Temperature Controller

Pump Iwaki Magnet Pump

35.6 gpm max flow rate

39 ft max head

TEC Heating/Cooling Trial 21

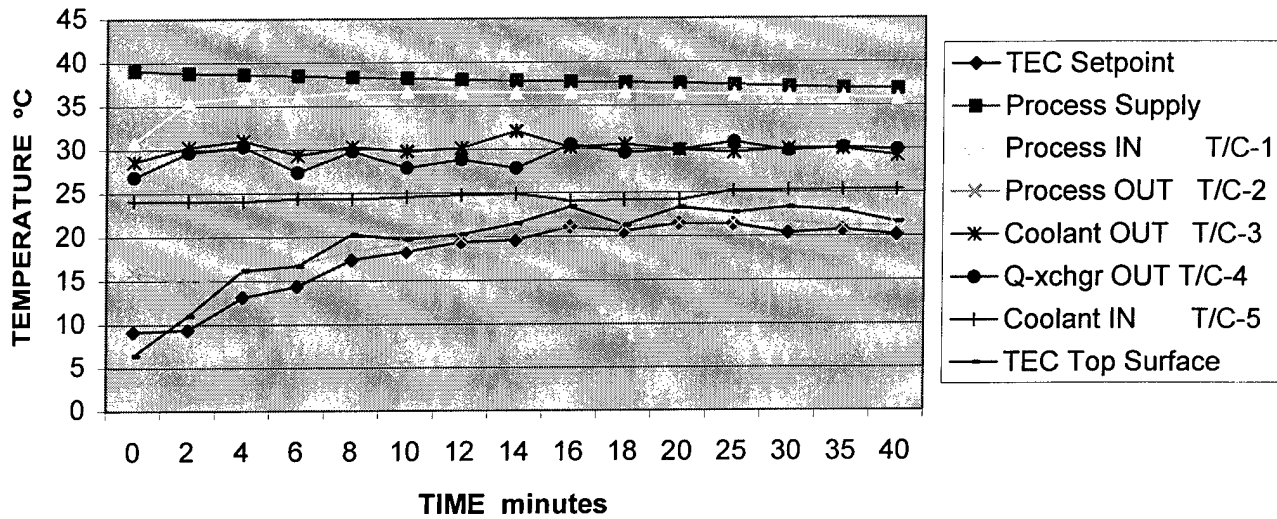

Process Flow Rate = 0.5L/min Coolant Flow Rate = 3.5gpm Target = 6°C Ambient = 20.0°C

	TIME minutes															
	0	2	4	6	8	10	12	14	16	18	20	25	30	35	40	
Process Supply	9.14	9.38	13.11	14.38	17.38	18.32	19.40	19.62	21.12	20.58	21.49	21.40	20.38	20.74	20.16	
Process IN T/C-1	39.1	38.8	38.7	38.5	38.3	38.2	38.0	37.9	37.8	37.7	37.6	37.4	37.2	37.0	36.9	
Process OUT T/C-2	30.83	35.50	36.11	36.17	36.56	36.67	36.56	36.56	36.50	36.61	36.39	36.28	36.11	36.00	35.78	
Coolant OUT T/C-3	16.00	14.61	15.89	16.78	18.50	19.17	19.89	20.50	21.06	21.11	21.61	21.57	21.67	21.17	21.17	
Q-xchgr OUT T/C-4	28.61	30.28	31.06	29.33	30.33	29.78	30.17	32.11	30.22	30.56	29.94	29.61	30.06	30.06	29.22	
Coolant IN T/C-5	26.83	29.67	30.33	27.39	29.78	27.89	28.83	27.83	30.57	29.61	29.94	30.83	29.78	30.17	29.94	
TEC Top Surface	24.11	24.11	24.06	24.39	24.33	24.56	24.78	24.89	24.11	24.17	24.17	25.22	25.28	25.33	25.33	
TEC Top Surface	6.4	11.0	16.2	16.7	20.3	19.7	20.3	21.5	23.4	21.3	23.3	22.7	23.3	22.9	21.6	

Cleanstream 1850-B Thermoelectric Heat Exchanger
 Switchback 6600 CE power Supply
 Yokogawa UT-450 Temperature Controller

Pump Iwaki Magnet Pump
 35.6 gpm max flow rate
 39 ft max head

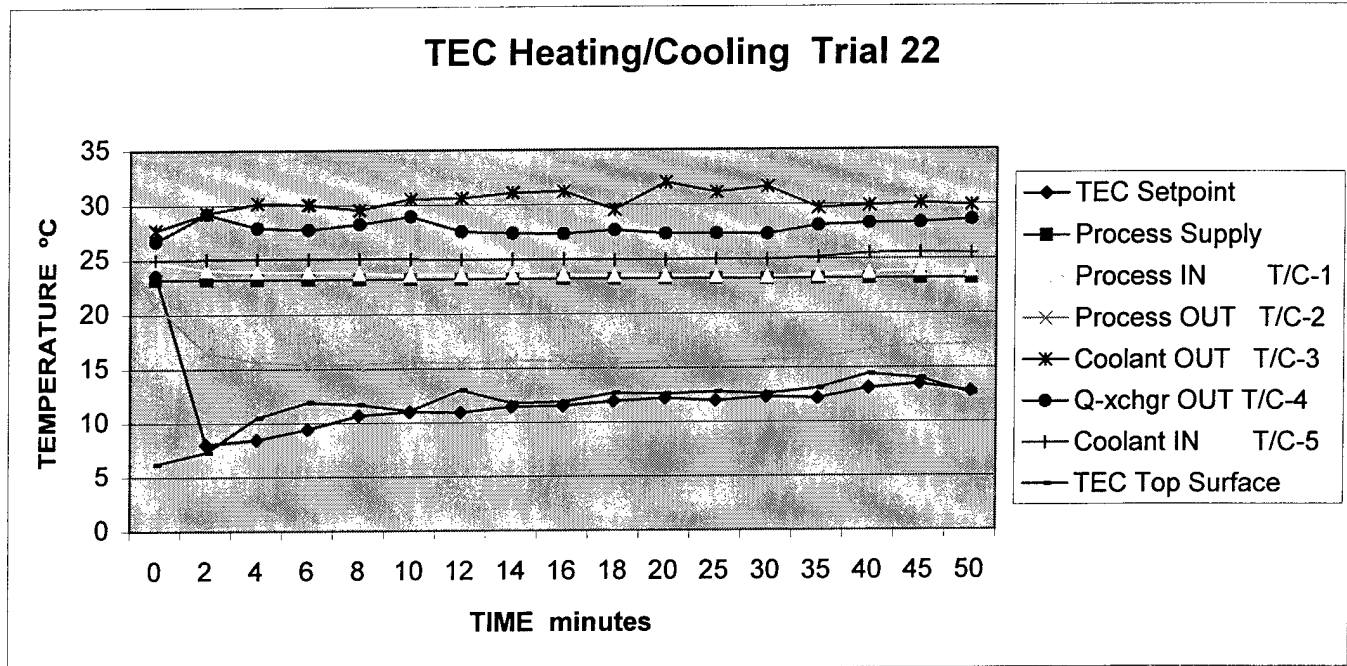

Process Flow Rate = 0.5L/min

Coolant Flow Rate = 3.5gpm

Target = 6°C

Ambient = 22.0°C

	TIME minutes																
	0	2	4	6	8	10	12	14	16	18	20	25	30	35	40	45	50
Process Supply	23.68	8.04	8.46	9.45	10.68	11.01	10.95	11.48	11.52	11.94	12.20	11.98	12.32	12.21	13.10	13.48	12.80
Process IN T/C-1	23.2	23.2	23.2	23.2	23.2	23.2	23.2	23.2	23.2	23.2	23.2	23.2	23.2	23.2	23.2	23.2	23.2
Process OUT T/C-2	24.83	24.11	23.94	23.94	23.78	23.61	23.61	23.56	23.61	23.5	23.5	23.44	23.39	23.50	23.78	23.94	23.89
Coolant OUT T/C-3	20.94	16.50	15.61	15.39	15.39	15.61	15.5	15.72	15.61	15.39	15.61	15.44	15.78	15.78	16.72	17.06	17.11
Q-xchgr OUT T/C-4	27.72	29.28	30.17	30.06	29.56	30.56	30.61	31.11	31.22	29.56	32.00	31.11	31.61	29.67	29.89	30.11	29.89
Coolant IN T/C-5	26.72	29.22	27.94	27.78	28.28	28.94	27.56	27.39	27.33	27.67	27.33	27.33	27.28	28.06	28.28	28.33	28.56
TEC Top Surface	25.00	25.06	25.11	25.06	25.11	25.06	25.00	25.00	25.00	24.94	24.94	25.00	24.94	25.17	25.50	25.56	25.50
TEC Top Surface	6.2	7.3	10.5	11.9	11.7	11.1	13.0	11.8	11.9	12.7	12.6	12.8	12.6	13.1	14.4	14.0	12.6

Cleanstream 1850-B Thermoelectric Heat Exchanger

Switchback 6600 CE power Supply

Yokogawa UT-450 Temperature Controller

Pump Iwaki Magnet Pump

35.6 gpm max flow rate

39 ft max head

TEC Heating/Cooling Trial 23

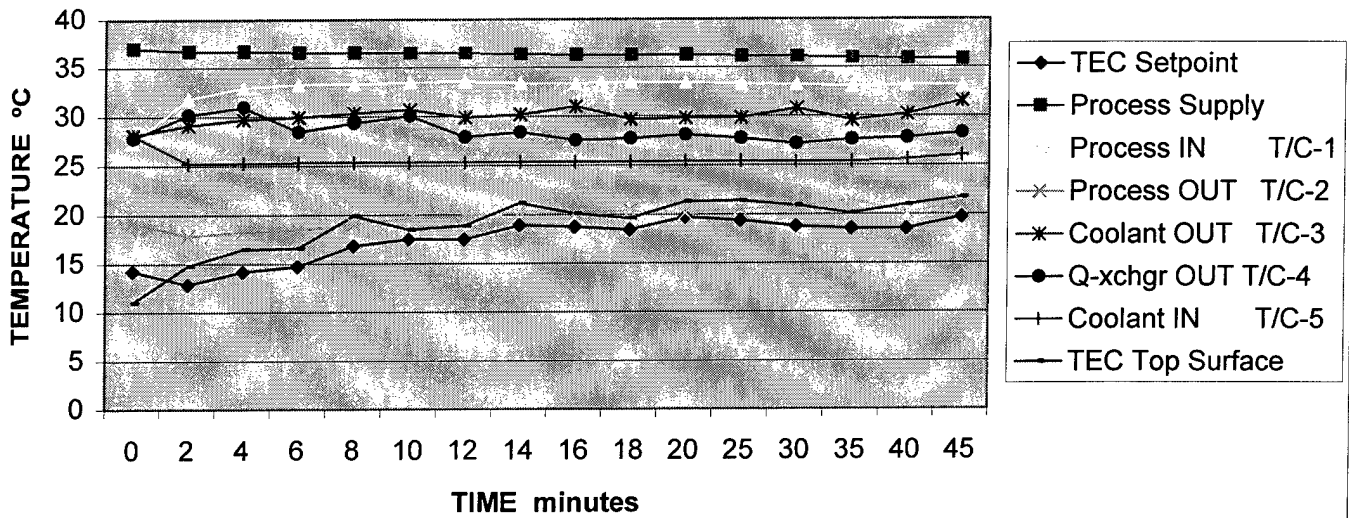

Process Flow Rate = 0.5L/min Coolant Flow Rate = 3.5gpm Target = 6°C Ambient = 22.5°C

	TIME minutes															
	0	2	4	6	8	10	12	14	16	18	20	25	30	35	40	45
Process Supply	14.26	12.87	14.19	14.74	16.83	17.51	17.48	18.93	18.74	18.43	19.73	19.38	18.79	18.56	18.52	19.74
Process IN T/C-1	37.0	36.7	36.7	36.6	36.6	36.5	36.5	36.4	36.3	36.3	36.3	36.2	36.1	36.0	35.9	35.8
Process OUT T/C-2	27.39	31.83	32.94	33.28	33.33	33.50	33.56	33.39	33.39	33.44	33.44	33.28	33.22	33.00	33.17	33.11
Coolant OUT T/C-3	19.17	17.83	18.28	18.44	19.06	19.61	19.83	20.22	20.17	20.39	20.17	20.56	20.72	21.44	20.17	21.11
Coolant OUT T/C-4	28.11	29.11	29.72	29.94	30.33	30.67	29.89	30.17	31.00	29.67	29.83	29.83	30.78	29.56	30.18	31.50
Q-xchgr OUT T/C-4	27.78	30.17	30.94	28.44	29.33	30.06	27.89	28.39	27.56	27.72	28.11	27.72	27.17	27.61	27.78	28.28
Coolant IN T/C-5	28.11	25.22	25.28	25.33	25.33	25.33	25.33	25.39	25.39	25.39	25.44	25.44	25.39	25.39	25.61	26.00
TEC Top Surface	11.0	14.8	16.5	16.6	19.9	18.5	18.9	21.2	20.1	19.6	21.3	21.4	20.9	20.1	21.0	21.7

Cleanstream 1850-B Thermoelectric Heat Exchanger
 Switchback 6600 CE power Supply
 Yokogawa UT-450 Temperature Controller

Pump Iwaki Magnet Pump
 35.6 gpm max flow rate
 39 ft max head

Conclusions

The TEC system utilized in the experimental setup could not meet the design parameter of a process fluid output temperature of 6°C. The failure of the TEC system is attributable to three major factors:

- Excessive heat buildup from the operation of the TEC system
- Insufficient coolant supply to the TEC system – both flow rate and inlet temperature
- Design of the heat exchange process within the TEC system.

The excessive buildup of heat within the TEC system is attributable to both the design of the TEC 'package' and also the physical operating principles (Peltier effect) of a thermoelectric device. The design and construction of the TEC system (Figure 2) contributes to a large buildup of heat within the system since both TEC layers have their 'hot side' facing the single coolant layer, which is in the center of the TEC assembly and functions as a large heat sink as well as a heat exchanger. As electrical current is passed through the TEC, a large amount of heat is generated on the 'hot' side of the TEC elements. Four times as much heat (4000 W) is generated by the TEC hot side alone as compared to the amount of heat (1074 W) removed from the process fluid by the TEC 'cold' sides. Since there are *two* TEC layers, the amount of heat removed from the process fluid by each TEC layer is 1074/2 W.

During the experimental trials, the flow rate of the coolant was doubled from 1.75 to 3.50 gpm. The performance of the TEC was increased, but still fell short of design parameters: 6°C @ 500ml/min. Recommendations from the TEC manufacturer were to increase the coolant flowrate to at least 6 gpm and also lower the coolant fluid inlet temperature (to the TEC) to 20°C and maintain the differential between coolant inlet and outlet temperatures at no greater than 5°C. Accomplishing these recommendations would require a very large pump operating at very high pressure and/or the use of chilled water as a coolant fluid. Having the ability to use chilled water for a coolant fluid would negate the need for having a TEC to begin with. Installing an even larger pump would make the overall setup large and cumbersome as well as requiring a plumbing layout (piping, fittings etc.) that could accommodate the increased pressure from the larger pump. The design of the cooling plate (Figure 2) permitted only a single pass of coolant fluid through the plate contributing to a nonuniform rate of heat transfer across the surfaces of the coolant plate. This meant that most of heat transfer (cooling) occurred near the inlet to the coolant plate and the rate of heat transfer was reduced closer to outlet of the coolant plate.

The methodology used within the TEC assembly to remove heat from the process fluid is very inefficient due to the design of the process and materials used. As shown in Figure 3, heat exchange from the process fluid takes place through plastic tubing. The PFA tubing has .013" wall thickness and 3/8" inside diameter. The plastic material itself is a barrier to heat flow and is a better insulator than conductor of heat. The diameter of the tubing is sufficient to allow laminar flow of the process fluid through the tubing. This means that the volume of blood flowing through the tubing, and not in contact with the tubing wall, is passing through the tubing with little heat loss occurring. Heat transfer from the process fluid takes place primarily by conduction. The TEC elements 'chill' the inner tubing plates, allowing heat transfer to occur from the process fluid to the tubing, to the inner tubing plate, to the TEC layer, to the coolant plate, to the coolant fluid. To maximize the effect of heat transfer by conduction, the plastic tubing needs to be in direct contact with the tubing plates around the entire outer surface of the tubing. Due to the plate design/fabrication and tubing mounting, the plastic tubing is

not in complete contact with the tubing plates around the entire perimeter of the plastic tubing. Some gaps are present which do not permit conduction and lower the overall heat transfer capability of the system.

Conduction is also the primary process by which the TEC elements transfer heat from the inner tubing plate and transfer heat to the coolant plate. For this process to be effective, the entire surfaces of the TEC, both top and bottom, must be in contact with the plates (coolant and inner tubing). As seen in Figure 4, the TEC elements are covered with a Thermal grease to fill voids and promote heat transfer by conduction. Many of the TEC elements did not have complete contact with the plates, allowing gaps to be present, inhibiting heat transfer.

An important point worth noting is that during the experimental trials, the temperature controller setpoint was never programmed lower than 6°C. To further decrease the temperature of the process fluid, the TEC system could be operated at a value lower than 6°C to overcome some of the thermal transfer inefficiencies of the overall system. This specific procedure was not attempted due to the inability of the experimental setup to dissipate the heat load even at a setpoint value of 6°C.

Based upon the inability of the TEC system to cool the process fluid down to the setpoint of 6°C at a flowrate of 500ml/min, it is apparent that the experimental setup would require some major modifications to achieve an outlet temperature of 6°C. TEC systems by their nature, are energy inefficient and a system constructed to meet design parameters (500ml @ 6°C) would have a high rate of power consumption as well as requiring a large secondary cooling system.

Suggestions for Further Work

The TEC system used in the experimental setup was inadequate to meet design parameters. A TEC system could be constructed to meet design parameters and would need to incorporate the following design conditions:

- Change in the design scheme of the assembly to have the TEC layers transfer heat to the outside of the assembly instead of towards the center, in current setup. This would split the total heat load in half to each outer surface allowing more expedient heat transfer.
- Provide multiple coolant paths, in parallel; through the coolant plates to permit more efficient and uniform heat transfer across the plates.
- Replace the plastic tubing as the primary heat exchange medium with a more heat conductive material and design which allows for greater surface area to contact the cooling plates and the process fluid.
- Design a more efficient means of heat transfer between the TEC layer and the coolant fluid by incorporating features such as material selection, fins, fans, increased coolant flow rate, greater coolant fluid surface area within cooling plate(s)
- As hardware modifications are completed, testing the system at a setpoint value *lower* than the specified output temperature (6°C) would overcome thermal transfer inefficiencies of the experimental system

APPENDIX J

BIOCONTROL
TECHNOLOGY INC.

TECHNICAL REPORT

#TECHRP REV. D

**RECORD #
269**

TITLE A Research Analysis of the Absorption Cycle Refrigeration		FILENAME TR_Hypo020528RG.doc	REVISION
PROJECT OR PROGRAM NAME Hypothermia Device Research		PROGRAM ROOT NUMBER 78	
PROGRAM TASK DESCRIPTION Research of Cooling Methods		PROGRAM TASK NUMBER 00	
NAME Ralph Gill		DEPARTMENT Mechanical Engineering	DATE 5/5/02
TECHNICAL AREA Refrigeration Concepts			
SUBJECT AND KEY TECHNICAL WORDS Refrigeration, Absorption, Hypothermia, Blood, Heat, Exchanger, Research			
DOCUMENTATION TYPE			
<input type="checkbox"/> Validation	<input type="checkbox"/> Error Budget	<input type="checkbox"/> Reliability	<input type="checkbox"/> Sensitivity
<input type="checkbox"/> Verification	<input type="checkbox"/> Product Support	<input type="checkbox"/> Risk Analysis	<input checked="" type="checkbox"/> Other
ASSOCIATED REPORTS 011029dk, 020513rg, 020520rg.doc			

Abstract

Existing absorption freezer/specifications would indicate that absorption cycle cooling is a valid alternative cooling method. The units are available that use either electricity or fuels for supplying the energy requirements. A commercially available unit will be purchased for test and evaluation.

Background

A task associated with the hypothermia research project is the search of existing technologies and their status for cooling processes need for development of devices need to enable the induction of hypothermia in humans.

Introduction

The major problem is to find viable techniques for cooling the blood extracorporeally. The approach must afford the cooling capacity required for the cooling process as well as being compact and light weight as possible. An additional property that is desired is that the concept allow a device to be developed that does not require an external electrical power source.

Purpose

The purpose of this literature search and analysis is to determine if the absorption cycle concept is a viable method for inclusion in a device that meets the portability and cooling requirements. This report is intended to present the findings associated with the absorption cycle cooling concept.

Description of Apparatus and Setup

No apparatus is required for this literature only search.

Summary of Data and Results

The Absorption Cycle Description:

The absorption cycle is very similar to the vapor compression cycle. For a vapor compression refrigeration cycle, shaft work is supplied to the compressor by some mechanism such as an electric motor or other source. The compressor raises the refrigerant vapor to a higher pressure, and consequently raises its condensing temperature.

The refrigerant vapor condenses to a liquid at this higher pressure and temperature. Because this condensing temperature is hotter than the ambient temperature, the condenser rejects heat to the ambient air. The high-pressure liquid then passes through a throttling valve that reduces the liquid's pressure. Reducing its pressure also reduces its boiling point temperature. The low-pressure liquid then passes into the evaporator and is boiled at this lower temperature and pressure. Because the boiling temperature is now lower than the temperature of the conditioned air, heat moves from the conditioned air stream into the evaporator and causes this liquid to boil.

Absorption chillers operate on the principle that some materials will absorb others - even when both are in a liquid form. Lithium bromide water solution is a liquid substance that absorbs water vapor.

One of the major differences between a conventional vapor compression cycle and an absorption cycle is the refrigerant used. Chlorofluorocarbons, or CFCs, have been the most popular refrigerants for mechanical refrigeration systems; however, water is used as the refrigerant most commercial absorption systems.

Unlike conventional mechanical compression systems, absorption cycles need a second fluid, the lithium bromide water solution, which is nontoxic. Because lithium bromide (the absorbent) does not boil, water (the refrigerant) is easily separated from it by adding heat.

In the absorption cycle, the thermal compressor represents a group of components because they serve the same purpose as a compressor, they take in low-pressure refrigerant and create high-pressure refrigerant.

How does a thermal compressor work? A thermal compressor requires two types of energy to operate: heat and work. Heat is required by the generator to boil the refrigerant from solution. This heat energy typically comes from natural gas. Work is required by the pump to raise the pressure of the solution from the lower evaporating pressure to the higher condensing pressure. This work energy is usually provided by an electric motor attached to the pump. Because it takes much less energy to pump a liquid than it does to compress a vapor, the thermal compressor requires much less electrical energy than an equivalent compressor used in a vapor compression cycle. However, the thermal compressor also requires heat energy.

The refrigerant vapor, which in an absorption cycle is typically water, passes from the thermal compressor to the condenser. This vapor is condensed to a liquid and the heat of condensation is rejected to the ambient air, just as in the vapor compression cycle. The liquid refrigerant now passes through a throttling valve that reduces its pressure, and thus reduces its boiling temperature. The low-pressure liquid refrigerant then moves into the evaporator, where taking heat from the conditioned air stream, again, just as in the vapor compression cycle boils the liquid.

Next, the liquid refrigerant passes into the thermal compressor component called the absorber. Strong absorbent solution is also added to the absorber. Because the absorbent solution does not have a lot of refrigerant in solution, it has a relatively strong affinity for refrigerant and is called a strong solution. In this way, the refrigerant vapor is pulled into

solution. Pulling the refrigerant into solution is called the absorption process. The absorption process releases heat in two ways: through the heat of condensation and the heat of mixing. The refrigerant, in turning from a vapor into a liquid, releases its heat of vaporization.

After the refrigerant vapor and the strong absorbent solution combine, the solution contains much more refrigerant than it did before. Thus diluted, the absorbent solution contains a lower concentration of absorbent and becomes a weak, rather than strong, solution. The weak absorbent solution is then sent through a pump and the higher-pressure, weak solution then passes into the generator. There, heat is added to separate and remove the refrigerant from solution. The higher-pressure refrigerant vapor then passes to the condenser and the now concentrated or strong solution is sent back to the absorber after its pressure is reduced through a throttling valve.

The cycle is used mostly for large air conditioning units, however a variation which uses ammonia, hydrogen gas and water is used in refrigerator/freezer units.

Ammonia/hydrogen cycle description:

In the lower portion of the cooling unit there is a bulb shaped container, called the absorber, holding a solution of ammonia and water, which is connected by a passageway to the siphon pump. The siphon pump is similar in operation to the center pipe of a coffee percolator. A heat source is applied (by a gas flame or an electric heating element) at the bottom of the siphon pump causing the ammonia/water solution to "boil" and form large gas bubbles. These bubbles push the ammonia/water solution to the top of the siphon pump where the now gaseous ammonia continues upward and the water separates out to flow down to a point where it is reused later.

It is a self-contained, sealed system containing ammonia, hydrogen, water and a corrosion-resisting agent (usually sodium chromate) the ammonia gas enters the finned condenser at the top of the cooling unit, where heat is dissipated to the atmosphere. As a result of this cooling effect, the ammonia vapor condenses to a liquid form and gravity takes over.

The liquid ammonia flows down to the evaporator tube located inside the freezer compartment, where it mixes with pure hydrogen gas, again allowing the ammonia to "boil". It takes heat to produce this change of state (liquid ammonia to vaporous ammonia) and this heat is extracted from the freezer compartment and the food contained within.

The weight of the ammonia/hydrogen mixture carries it down to the absorber bulb at the bottom of the cooling unit, where the water in the system absorbs the ammonia. The released hydrogen (a very light gas) rises through the absorption tube passing over the water that is running down from the siphon pump (discussed above) and the remaining ammonia is absorbed. Therefore pure hydrogen is available again at the evaporator and the water/ammonia mix in the absorber bulb can continue the cycle. This is the basic operation of the absorption-cooling unit. Other components are involved to control the temperature settings.

There are existing commercial units available that could be used for a portable cooling unit for the blood heat exchanger.

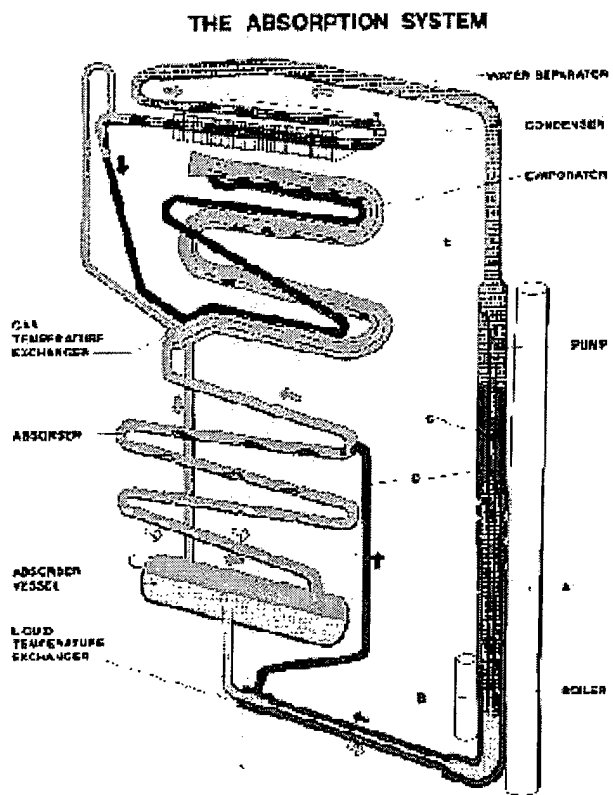

Figure 1
Schematic Diagram of a Typical Absorption Refrigerator

Conclusions

Existing units are available for possible use as a cooling unit for the hypothermia heat exchanger.

Suggestions for Further Work

A commercial unit will be purchased and the method evaluated for further testing.

TECHNICAL REPORT

#TECHRP REV. D

RECORD #
274

TITLE Electrical Power for Portable Hypothermia Devices		FILENAME TR_Hypo020727CR.doc	REVISION 00
PROJECT OR PROGRAM NAME Hypothermia		PROGRAM ROOT NUMBER 78	
PROGRAM TASK DESCRIPTION Electrical Power Sources in Transport Vehicles		PROGRAM TASK NUMBER 00	
NAME Charles Rapach		DEPARTMENT Engineering	DATE 7/18/2002
TECHNICAL AREA Electrical Power Availability			
SUBJECT AND KEY TECHNICAL WORDS Power, Ambulance, Rescue, Helicopter, Vehicle			
DOCUMENTATION TYPE			
<input type="checkbox"/> Validation	<input type="checkbox"/> Error Budget	<input type="checkbox"/> Reliability	<input type="checkbox"/> Sensitivity
<input type="checkbox"/> Verification	<input type="checkbox"/> Product Support	<input type="checkbox"/> Risk Analysis	<input checked="" type="checkbox"/> Other
ASSOCIATED REPORTS			

Abstract

Review electrical power capabilities of emergency vehicles such as ambulances, mobile ICU/Trauma vehicles and life flight helicopters for use in defining input requirements for Hypothermia device.. Most vehicles equipped for medical rescue have at least one 115 volt AC outlet capable of suppling up to 1000 watts, but long term operation at full power may not be possible. Loads of 2000 to 3000 watts are not possible in standard ambulances, but could be supported in larger emergency vehicles that have auxiliary generators. Power management may be necessary by the operators of the vehicle.

Background

Some of the devices proposed under the Hypothermia Research program are intended to be portable for use in the field away from mains power. Ideally, these devices would be self-powered or have their own batteries. However, in some proposed implementations the device will need outside power to maintain temperature in standby or it will need a large amount of power for a short period of time to perform the cooling process.

Introduction

Portable Hypothermia devices may require large amounts of electrical power (2000 to 3000 watts) to either maintain temperature of a cooling medium or to do the actual cooling of the body. Long term power availability in a vehicle is limited to what can be generated by the electrical system with the engine running. Short term loads can exceed this power level, but usually only for a few minutes depending on the battery reserve capacity.

Purpose

The purpose of this report is to determine what sources of electrical power are likely to be available in medical vehicles to operate a portable hypothermia device.

Description of Apparatus and Setup

No apparatus is required for this literature only search.

Summary of Data and Results

Wheeled commercial emergency vehicles will have 12 volt DC electrical systems powered by one or more engine driven alternators. A storage battery is part of the system for starting the engine and for short term operation with the engine not running. Typical battery capacity is about 70 amp-hours. The battery can also absorb transient loads that exceed the alternator capacity. The system voltage with the engine running is a nominal 14 volts and drops to 12 volts or less under load with the engine stopped, so devices that draw high current will not work as well with the engine stopped.

A typical ground ambulance will have an alternator capacity of 220 to 270 amps at 14 volts. This limits the total power available to 3080 to 3780 watts. Lights, sirens and controls use most of this total, so there is only 1000 to 2000 watts available for additional medical equipment. Outlets for 115 volt 60 cycle power powered by an inverter can supply up to 1000 watts, but operating procedures say that other electrical loads should be reduced if a heavy load is connected to the 115 volt outlet. The minimum power requirement to meet Federal Ambulance Specification KKK-A-1822E is 750 watts continuous output at 115 volts. Twelve volt outlets are rated at 20 amps which limits available power to 250 watts. Ambulances can be equipped with a shore line which is a connection for 115 volt AC power when the vehicle is parked at its home station. Shore line connections are rated 15 to 20 amps at 115 volts. Electrical equipment can then be run indefinitely without drawing power from the vehicle electrical system. Large rescue vehicles equipped for heavy electrical power demands have auxiliary gas engine generators which can provide up to 10,000 watts of power. A typical use would be to provide flood lighting at the emergency location.

Helicopters are used as air ambulances because they can greatly reduce the transport time of critically injured people. It is the emergency vehicle of choice in remote areas because the victims can be quickly taken to large trauma centers where they can receive the best treatment. The basic electrical system of a helicopter is 28 volts DC. Generator capacity ranges from a single 130 amp to dual 200 amp units for helicopters used as ambulances. Standard battery capacity is about 22 amp-hour. Probably because of weight concerns there is less electrical reserve capacity in a helicopter than in a ground vehicle. Large helicopters (15 passenger or more) can have dual 20 kilowatt 115 volt 400 hertz alternators, but these helicopters are not normally used for ambulance or rescue service. Standard equipment power inverters are usually 250 to 500 watts for 115 volt AC power. Medical equipment can include up to 1500 watt inverters.

Most of the above information was gathered from the manufacturers specifications for the different vehicles. Actual equipment used in the field was sampled by visiting a local ambulance company to examine their equipment level. They have a fleet of approximately ten type III ambulances (medical equipment box mounted on truck chassis). Some are called mobile intensive care units or medic units and have extra monitoring and medical capabilities. All units have 12 volt DC outlets and 115 volt AC power from a 1000 watt inverter available in the ambulance. None of the units have auxiliary generators.

The local hospital has a life flight helicopter stationed there. Its power capabilities are 28 volts DC and 115 volts AC from a 1500 watt inverter. The operators of the ambulances and the helicopter both said there was adequate electrical power in their vehicles.

Conclusions

A typical modern medical emergency vehicle would be able to supply up to 1000 or 1500 watts from a 115 volt AC outlet for a hypothermia device. For some vehicles, this could be as much as one-half of its generating capacity, so some power management may be necessary by the operators of the vehicle if this load is maintained for a long period of time. Low power loads in the 250 to 500 watt range are possible from the 12 or 28 volt outlets. Higher power demands in the 2000 to 3000 watt range are not possible in most medical vehicles without the addition of special equipment for that purpose.

Suggestions for Further Work

No suggestions for further work.

References

Federal Specification for the "Star-of-Life Ambulance", KKK-A-1822E

APPENDIX L

TITLE Characterization of Dometic portable refrigerator/freezer		FILENAME TR_Hypo 020828DF.doc	REVISION 00
PROJECT OR PROGRAM NAME Hypothermia Device Research		PROGRAM ROOT NUMBER 78	
PROGRAM TASK DESCRIPTION 20L IV bag cooling methods (Profound Hypothermia)		PROGRAM TASK NUMBER 00	
NAME Dave Felton (test) / Shawn Nesmith (design)		DEPARTMENT Test Engineering	DATE 8/28/02
TECHNICAL AREA Device Characterization			
SUBJECT AND KEY TECHNICAL WORDS Characterization of the cooling capacity of the Dometic brand portable refrigerator/freezer			
DOCUMENTATION TYPE			
<input type="checkbox"/> Validation	<input type="checkbox"/> Error Budget	<input type="checkbox"/> Reliability	<input type="checkbox"/> Sensitivity
<input type="checkbox"/> Verification	<input type="checkbox"/> Product Support	<input type="checkbox"/> Risk Analysis	<input checked="" type="checkbox"/> Other
ASSOCIATED REPORTS TR_Hypo 020717 DF.doc			

Abstract

This report details the results of the characterization tests performed on the Dometic brand "PowerFridge" portable refrigerator/freezer, which is one of the possible candidates to be used on the profound hypothermia project. The freezer was able to chill a 20L bag of water at room temperature down to 3°C in roughly 41 hours, and was able to maintain it at that temperature.

Background

The Hypothermia Program is a research and development program funded by the Department of the Army in cooperation with Safar Research Institute in Pittsburgh, PA. The proposed device will store large volumes (10 to 40L) of sterile cold flush solution at a temperature of -5 to 5°C . The sterile cold flush solution will be administered to a subject at a delivery rate of about 2L/min, lowering the core body and brain temperature to around 10 to 20°C causing profound hypothermia. Initially this device is to be used in a hospital emergency room environment with sufficient external power. However, further consideration must be given to develop a device that can be transported by emergency vehicles, such as ambulances and/or helicopters. Therefore, the device will need to have an internal power supply, or operate off the emergency vehicles limited power supply.

Introduction

One of the proposed methods of administering profound hypothermia is to chill a 20L IV bag of sterile cold flush solution to 0°C , which will then be used in a flush of the body's circulatory system at a rate of about 2 L/min. To chill the 20L bag of sterile solution, Biocontrol engineering procured a portable absorption cycle refrigerator/freezer, Model PowerFridge RC3000, from Dometic in LaGrange, IN.

Purpose

The purpose of this test was to characterize the portable freezer's capability to chill a 20L bag filled with water from room temperature down to 0°C and maintain that temperature.

Description of Apparatus and Setup

The factory temperature control of the portable freezer had to be bypassed to allow a closed loop control of the IV bag's water temperature to an accurate set point. The thermostat included in the freezer was set on max cool so that it would not switch off during the testing, and an Omega Model CN132 temperature controller was installed. The temperature feedback for this controller was a hypodermic needle T-type thermocouple that was punctured into the IV bag. Power for the Omega controller was a separate 12VDC supply. The controller was set up to be an ON/OFF control, with a 1-degree bandwidth, and in cooling mode, so that the output relay would close when the IV bag water went above the set point.

This test was performed with the PowerFridge using 120V AC as the power source. The PowerFridge can also operate with 12V DC (battery) or with propane. The AC current supplied to the refrigerator was monitored using a digital wattmeter, Vector-Vid Model WD-766A. A Yokogawa MV112 data logger was used to record significant temperatures, which included the ambient temperature inside the freezer, room temperature, the freezer inner evaporator wall temperature, IV bag water temperature, and a refrigerator ON/OFF signal. Figure 1 shows a schematic of the test setup.

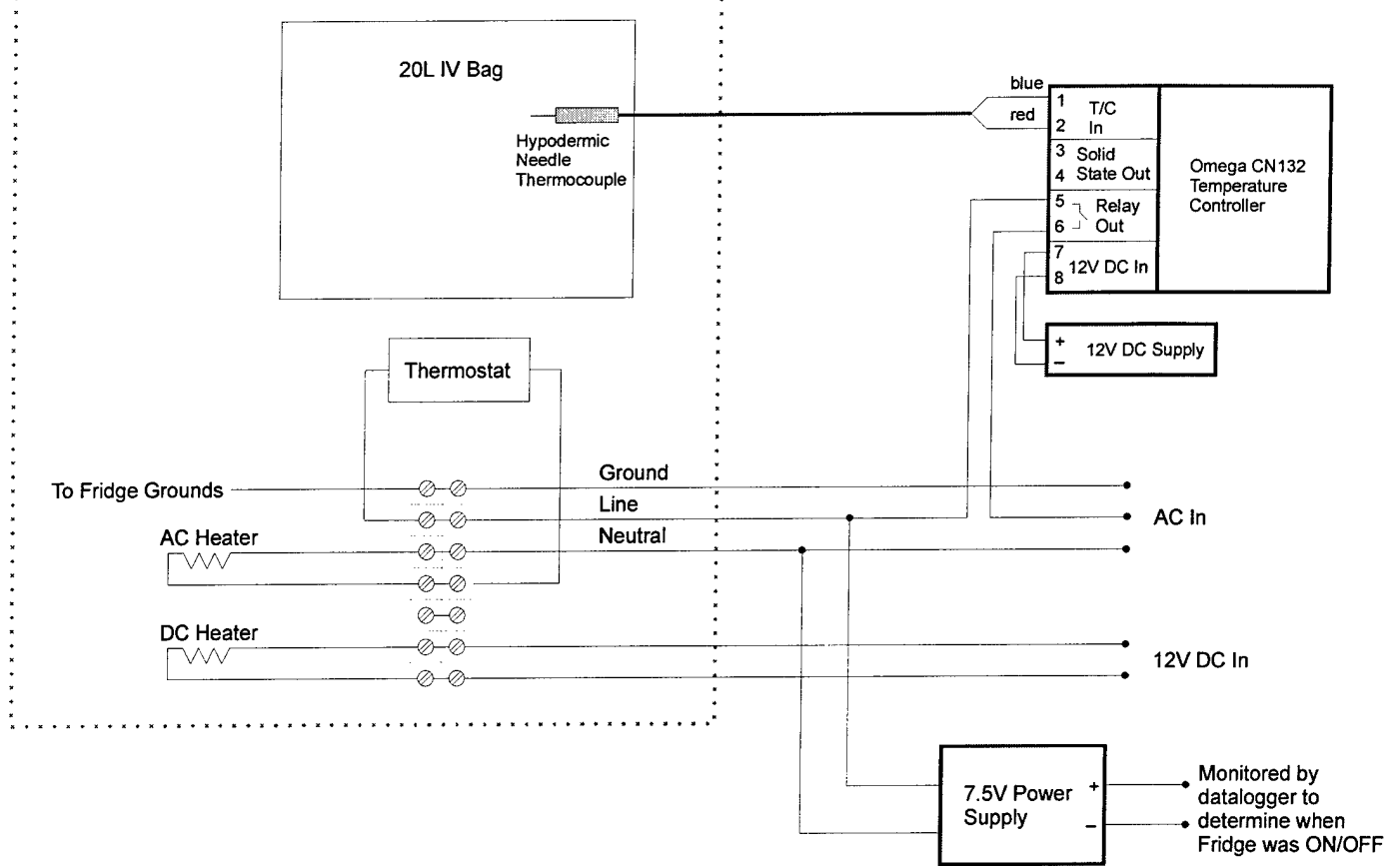

Figure 1

Figure 2 below shows the PowerFridge with the service panel removed to provide access to the terminal strip.

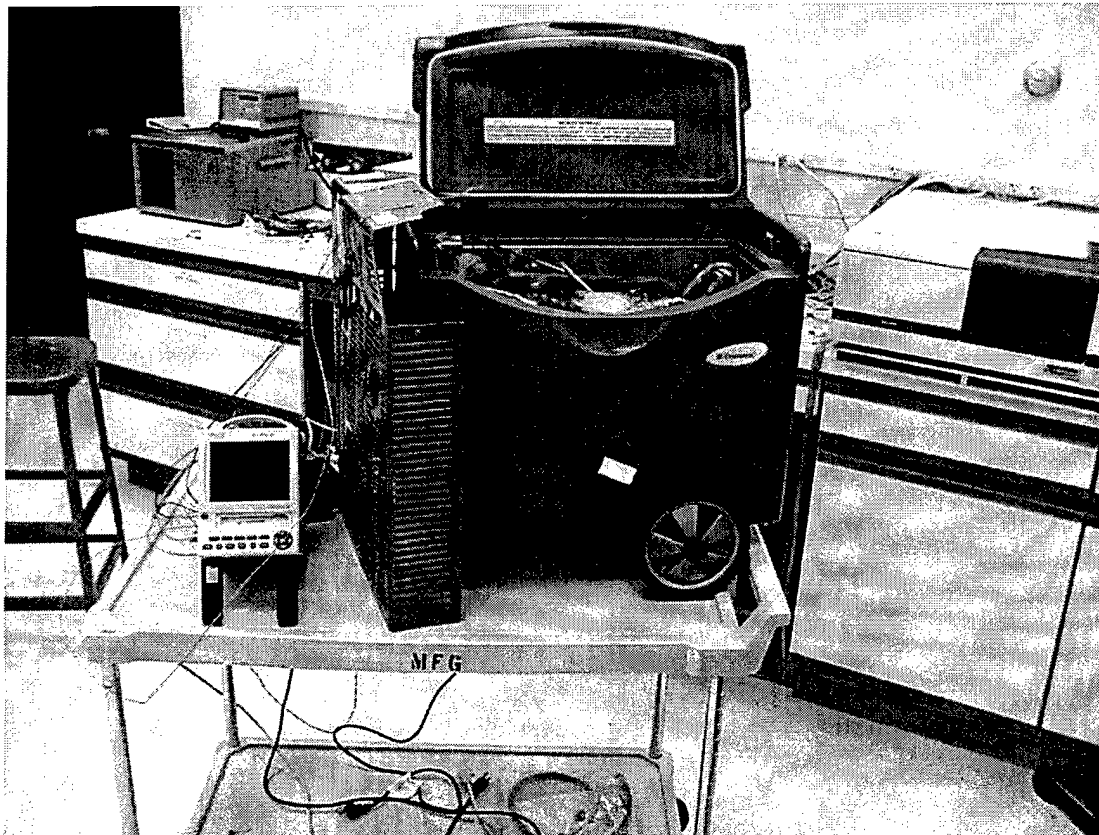

Figure 2

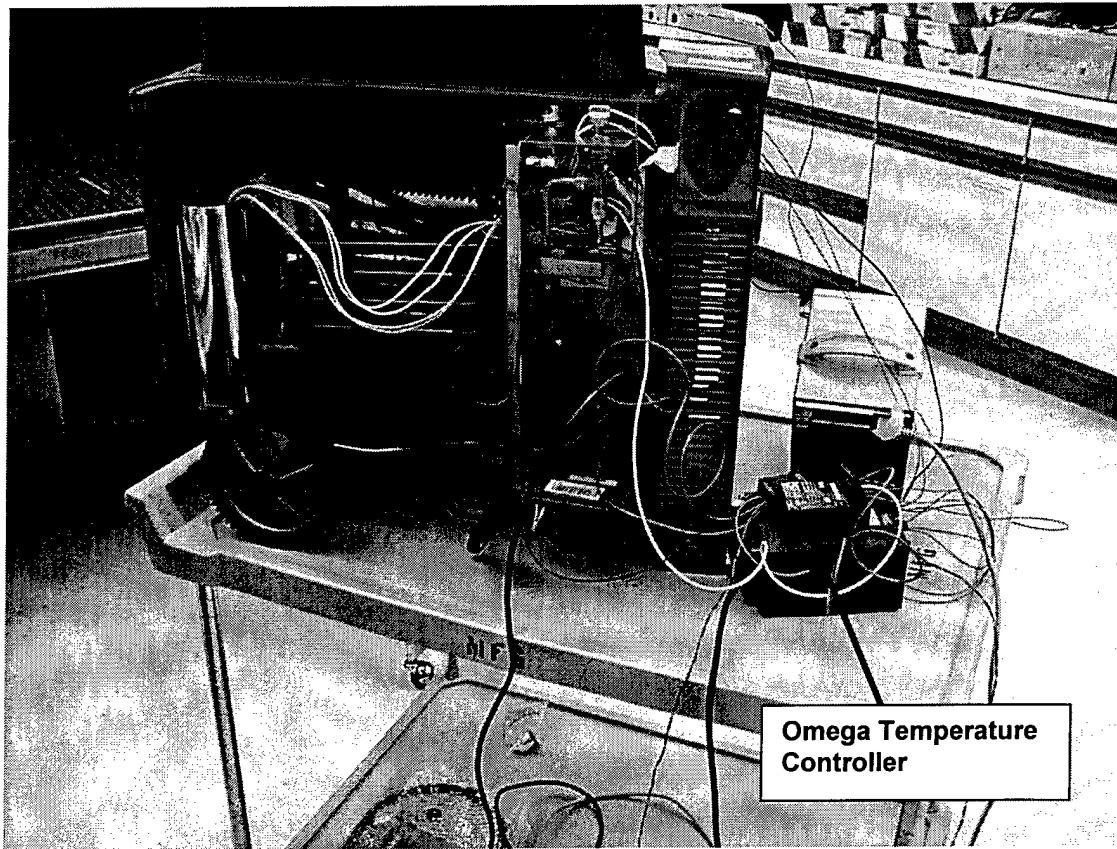

Figure 3

Figure 4 shows the 20L bag inside of the freezer with the hypodermic needle thermocouples punctured into it. A patch of silicon sealer was allowed to cure on the bag first to help prevent leaking around the puncture holes.

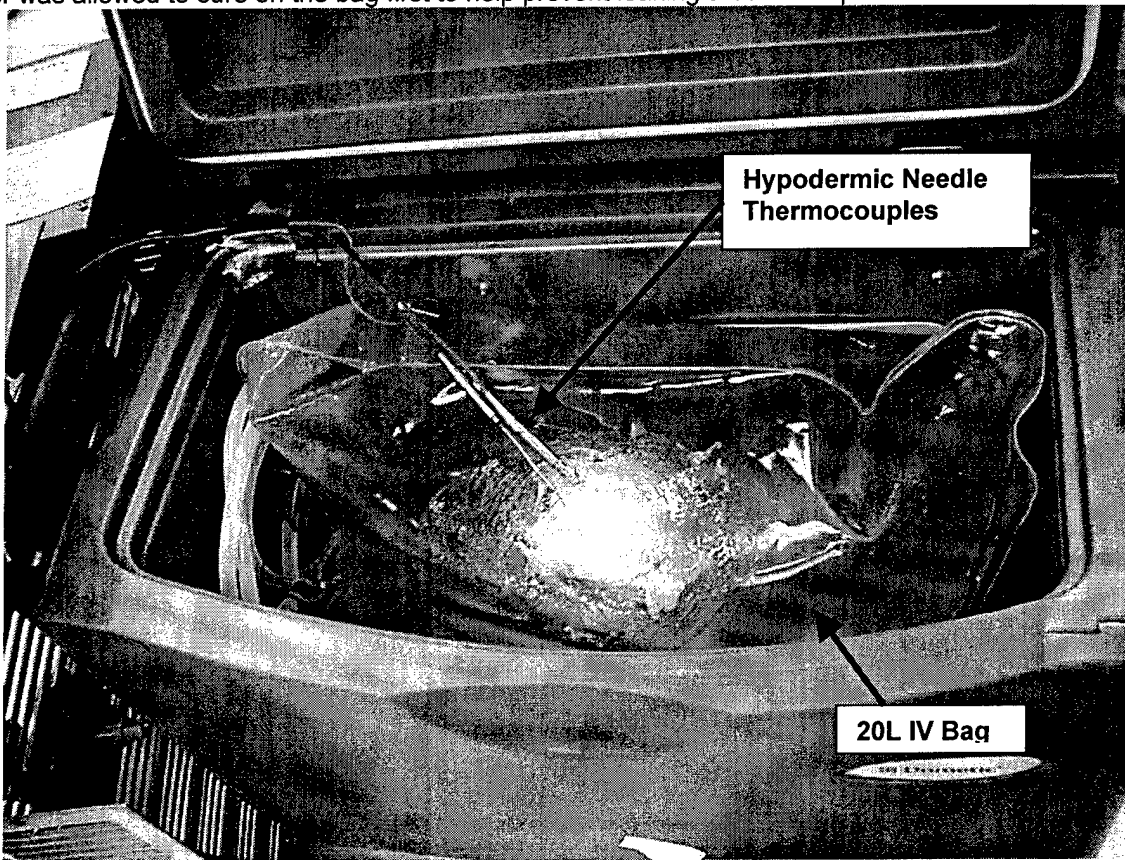

Figure 4

Summary of Data and Results

Figure 5 shows the 20L IV bag water temperature (purple line) from turn-on through 2 days of running. The set point on the Omega controller was 1°C (we did not want the water to freeze, therefore, a set point of 1°C was used instead of 0°C). At about 41 hours, the temperature of the water reached the set point, however, the thermocouple that the Yokogawa recorded read about 3°C. The other two lines that follow the water temperature show the freezer inner wall temperature and the freezer inner ambient temperature. The dark blue line shows the room ambient temperature. The dark purple line at the top shows the freezer ON/OFF indicator. This was a 7.5V power supply powered from the AC fed to the freezer from the Omega controller, so it was powered when the freezer was running and 0V when the freezer was off.

Dometic Cool Down

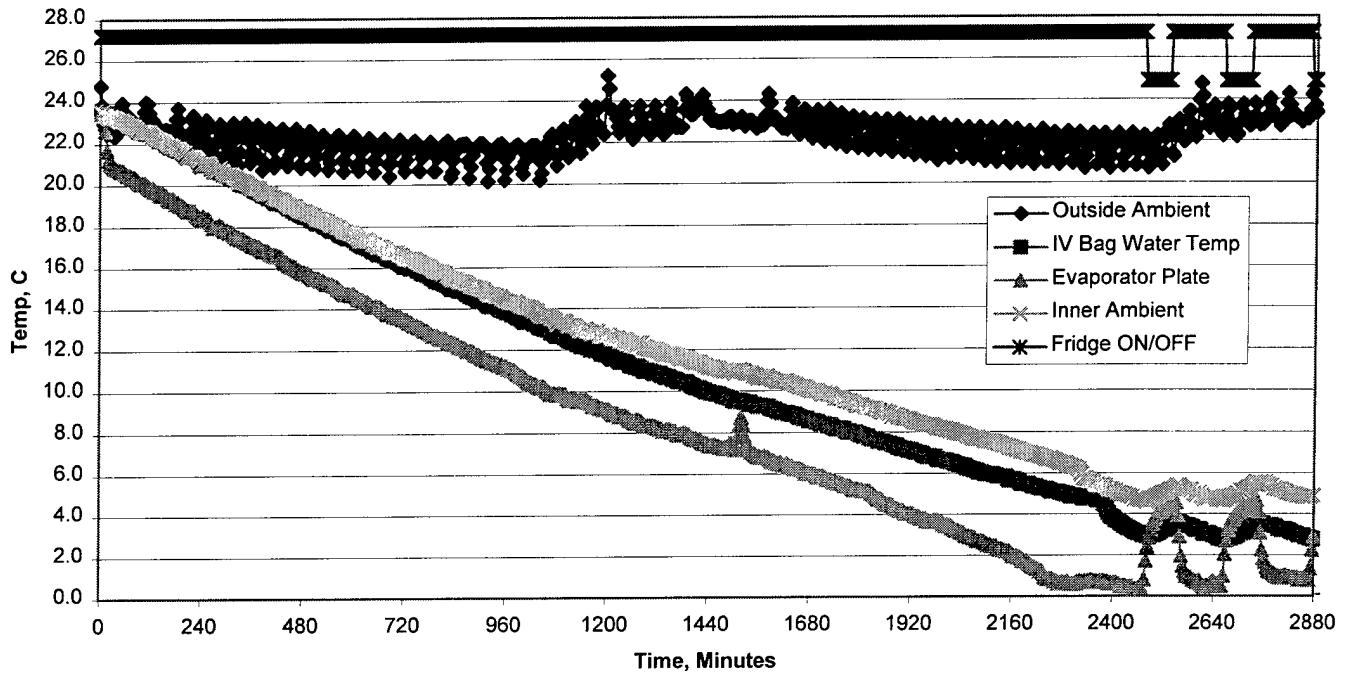

Figure 5

Figure 6 shows how well the PowerFridge maintained the IV bag water temperature at the set point. The temperature was held within 1°C over the test. The Omega controller's bandwidth could be set tighter than the 1 degree that was used for this test, possibly narrowing the temperature swing of the water further if needed.

Dometic Temperature Hold

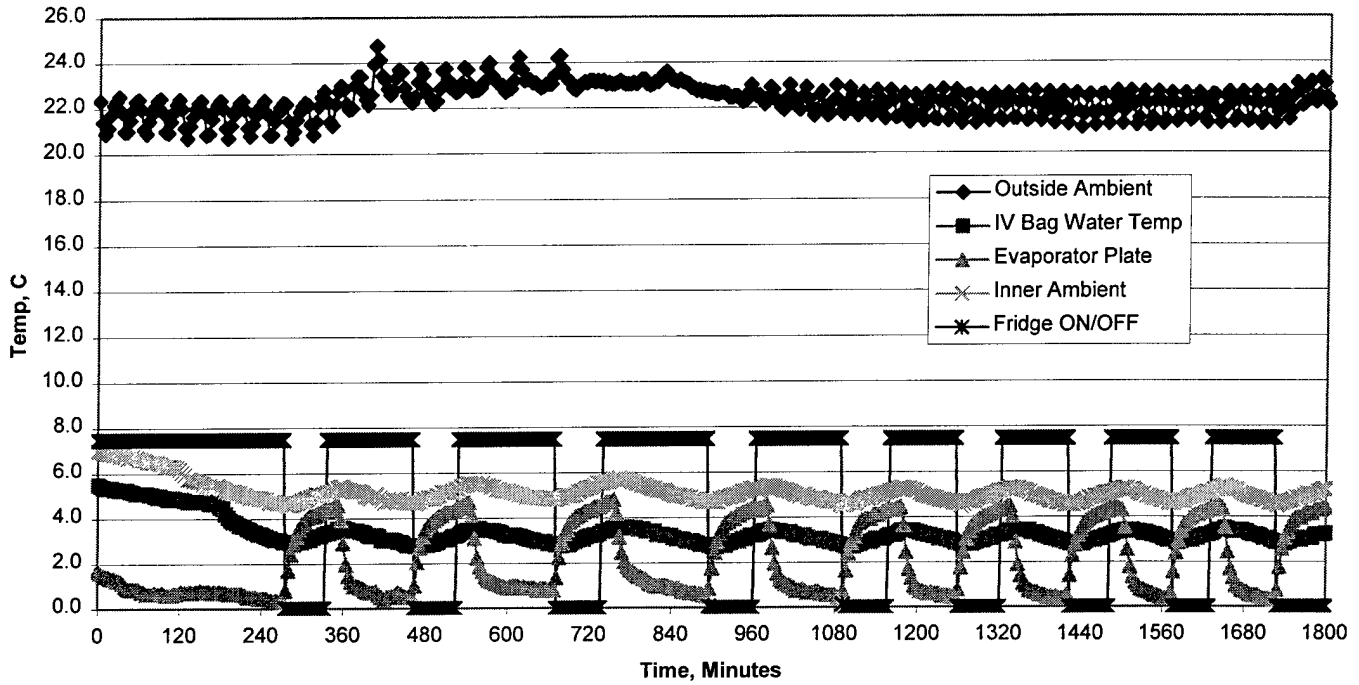

Figure 6

For the final test, the temperature controller and freezer were shut off, and the IV bag was allowed to warm-up naturally. The purpose of this test was to see how well the freezer was insulated. Figure 7 below shows the result over a 4-day span.

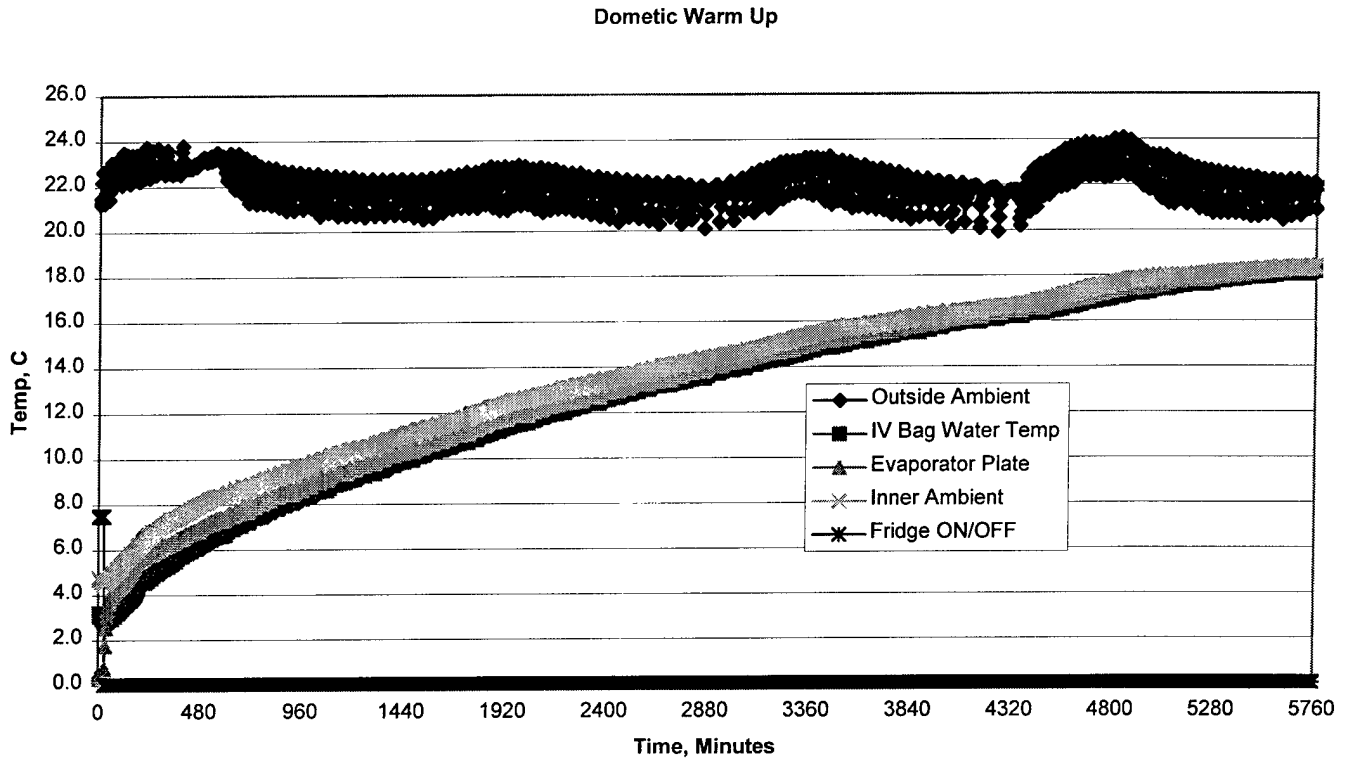

Figure 7

The AC current on the 120VAC line stayed constant at 0.7A AC throughout the test.

Conclusions

Since this was a characterization test, there are no conclusions to be derived for the recorded data.

Suggestions for Further Work

None

APPENDIX M

TECHNICAL REPORT

#TECHRP REV. D

**RECORD #
279**



TITLE Induction of Mild to Moderate Hypothermia via TEC Cooling		FILENAME TR_Hypo 020903SN	REVISION 00
PROJECT OR PROGRAM NAME Mild to Moderate Hypothermia Device		PROGRAM ROOT NUMBER 78	
PROGRAM TASK DESCRIPTION TEC Cooling Method		PROGRAM TASK NUMBER 00	
NAME Shawn Nesmith (Design Eng.) / Chuck Rapach (Electrical Eng. / Testing)		DEPARTMENT Program Management	DATE 9/3/02
TECHNICAL AREA Design Verification			
SUBJECT AND KEY TECHNICAL WORDS Hypothermia, Thermoelectric Coolers (TEC), performance			
DOCUMENTATION TYPE			
<input type="checkbox"/> Validation	<input type="checkbox"/> Error Budget	<input type="checkbox"/> Reliability	<input type="checkbox"/> Sensitivity
<input type="checkbox"/> Verification	<input type="checkbox"/> Product Support	<input type="checkbox"/> Risk Analysis	X Other
ASSOCIATED REPORTS TR_Hypo020822 WN			

Abstract

This report presents the design and test results of an improved thermoelectric cooling prototype device for the mild to moderate hypothermia requirements. The first version, described in technical report TR_Hypo 020822 WN.DOC, failed to provide the required cooling. This version meets the cooling requirements under most conditions, but the overall size of the system and the electrical power requirements may limit practical application of this device.

Background

The Hypothermia Program is a research and development program funded by the Department of the Army in cooperation with Safar Research Institute in Pittsburgh, PA. The proposed device will cool the human body's core temperature between 36°C to 32°C putting it into a state of mild to moderate hypothermia. This will be done by externally (veno-venous or arterio-arterial) cooling the blood from 37°C (normal body temperature) to a target of 10°C at a flow rate of about 500 ml/min. Initially, this device is to be used in a hospital emergency room environment with sufficient electrical power supply and space. However, future consideration must be given to develop a device that is portable by one individual and self-supportive from its own electrical power supply. Therefore, size, weight and overall efficiency of the device is an ongoing issue.

Introduction

Thermoelectric cooling is one of the practical methods that could be used in a device for rapid cooling of the blood. Sufficient cooling capacity can be obtained in a relatively small package and only DC current is necessary to operate the cooler.

The first version thermoelectric cooling device was purchased from Solid State Cooling Systems. Testing of this device is described in the associated report, which also covers the theory of operation for thermoelectric cooling. It was not able to cool the process fluid at the required flow rate. An analysis of its construction and performance led to the design of an improved version that is more thermally efficient. The cold side is moved to the center. The thermal resistance between the process fluid and the cold side is reduced. Individual heat sinks are used for each TE module and a larger thermoelectric module is used.

Purpose

The purpose of this technical report is to evaluate the potential for cooling blood (water in our case) from 37°C to 10°C using thermoelectric coolers (TEC's). This must be done by passing water through a heat exchanger and removing heat from it. Only one (1) pass through the heat exchanger is permitted.

Description of Apparatus and Setup

In this experiment, the process fluid (water) is pumped through two (2) Gaymar Industries Hi Flow Disposable Warmer Cassettes part no. D25330CE (Figure 1) connected in series. Each disposable cassette is inserted between two (2) cold plates (Figure 3) that make up a zone; therefore, two (2) zones are utilized in this experiment. Each zone contains sixteen (16) Melcor CP5-31-06 thermoelectric coolers (TEC's) and sixteen (16) Melcor LI-301 liquid heat sinks (Figure 2). Each TEC is mounted between a spacer plate and a liquid heat sink with a .0005" layer of thermal grease on each side of the TEC to help with heat transfer. The TEC's are connected electrically in series with each other and also between the two (2) zones (Figure 4)

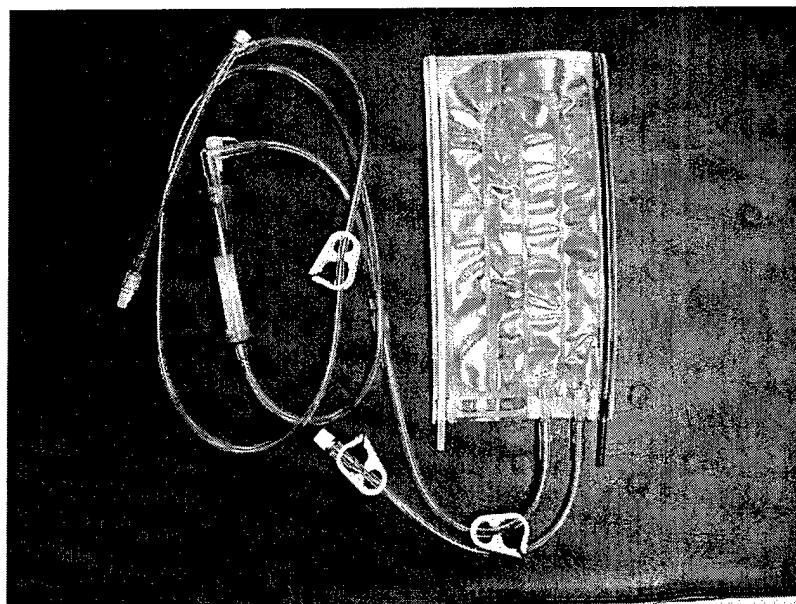

Figure 1. Gaymar Hi Flow Disposable Warmer Cassette

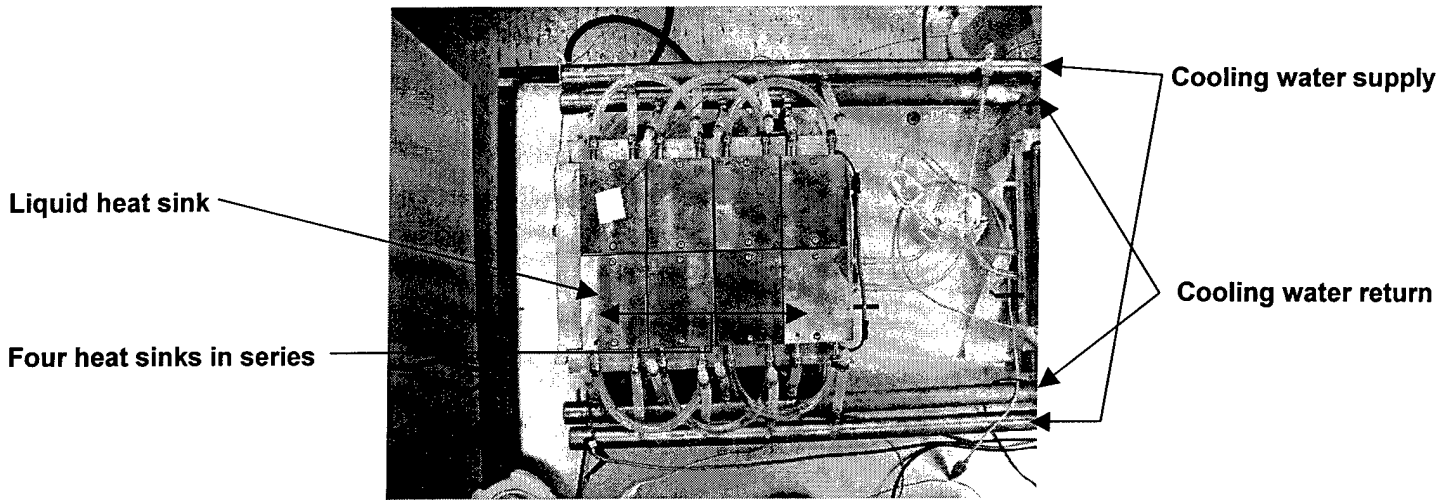

Figure 2. TEC and Heat Sink Assembly Top View – one (1) zone

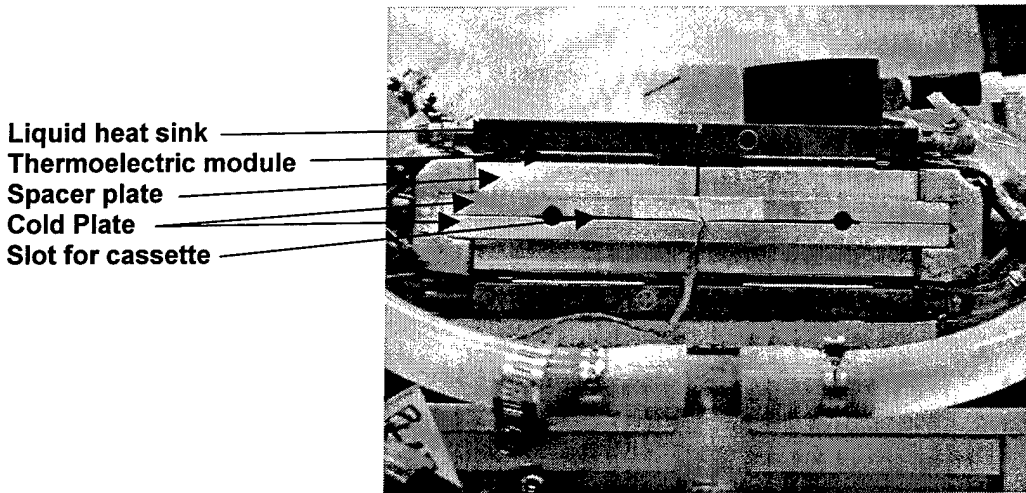

Figure 3. TEC and Heat Sink Assembly End View– one (1) zone

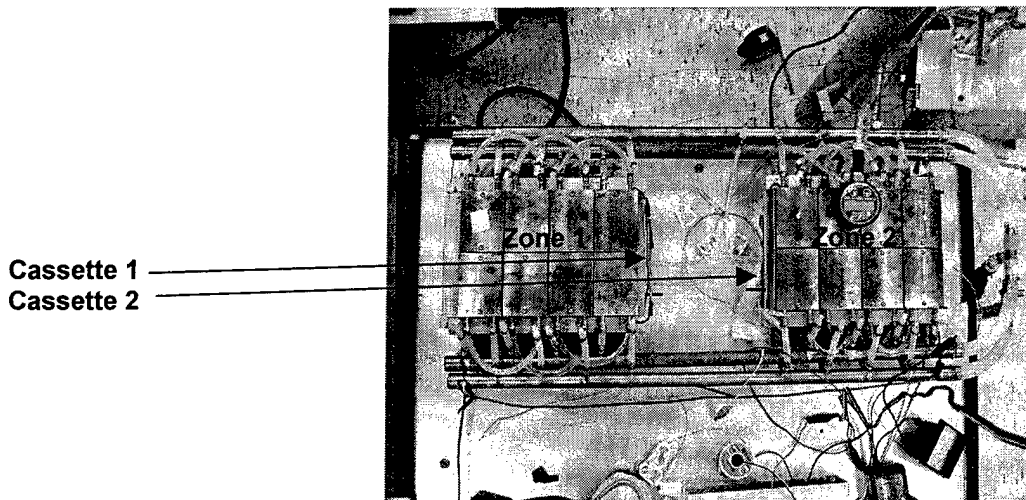

Figure 4. TEC Two Zone Assembly Top View

Figure 5 shows the TEC based direct cooling test setup. In this experiment, the process fluid is pumped, via a Cole-Parmer Masterflex 77200-62 peristaltic (roller) pump (can be seen in Figure 5), from a supply reservoir to the disposable cassettes located in zone #1 of the TEC assembly. Once the process fluid exits zone #1, it is routed to zone #2 for further cooling. After exiting zone #2, the process fluid passes through a Cole-Parmer 100-1500 ml/min flow meter. This flow meter helps in properly measuring the flow rate obtained by the roller pump. Once the process fluid flows through the flow meter, it is then captured in a discharge reservoir.

The process fluid temperature is measured, using Omega Hypodermic Needle Probe type HYP2 thermocouples, and stored on a Yokogawa MV112 data acquisition system (see Figure 5). The process fluid inlet temperature prior to zone #1 and outlet temperature after zone #2 are recorded. These temperatures are used to calculate the amount of heat removed from the process fluid.

In order for the TEC's to perform efficiently, heat needs to be removed from them. Therefore, as you can see in Figure 5, a cooling loop is installed for proper cooling. The cooling loop is comprised of a centrifugal pump, Iwaka MD-100RT, which pumps the coolant from a holding tank through the liquid heat sinks mounted to the TEC's. Once the coolant exits the liquid heat sinks, it enters two (2) liquid to air heat exchangers, Thermacore 5360, where it is cooled by fans blowing ambient air through the fins and dumped back into the holding tank. The liquid to air heat exchangers water path is connected in series for the first test runs and in parallel for the later runs. This was done to increase the flow rate through the liquid heat sinks mounted on the TECs. The temperature of the cooling water is measured at the inlet and outlet of the TEC assemblies and recorded by the MV112 data recorder.

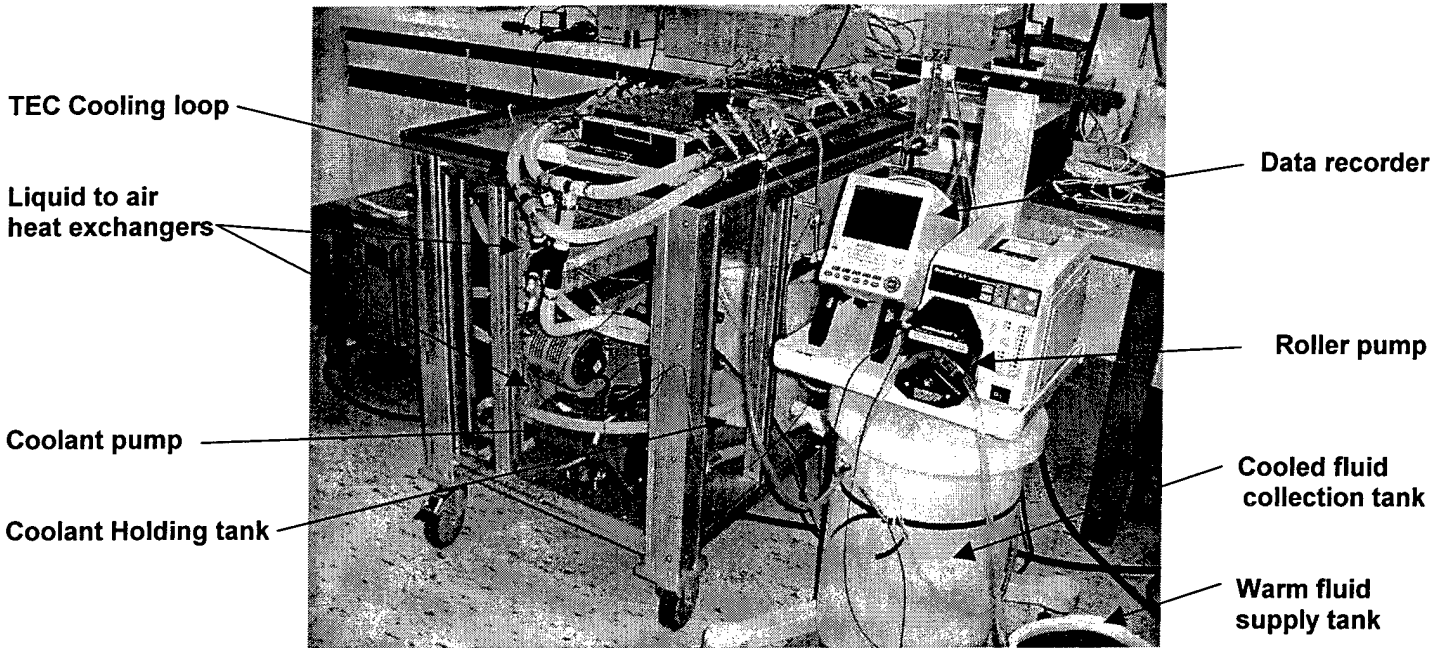

Figure 5. TEC Based Direct Cooling Test Setup

Several combinations of hot side cooling plumbing were tried before settling on a final test configuration. Removal of the heat from the hot side of the TEC modules seems to be the performance limiting factor in this type of cooling device. There are a total of thirty two (32) TEC modules and thirty two (32) liquid heat sinks, one per module. Each one has a ¼" OD water inlet and outlet. In the initial set up the connection was four (4) sets of eight (8) liquid heat sinks in series. This was changed to thirty two (32) in parallel and then finally to eight (8) sets of four (4) in series. The liquid to air heat exchangers were changed from a series to parallel connection and restrictions were removed from the cooling water path to increase the cooling loop flow rate.

The TEC modules are powered by a constant current DC switching supply with a maximum current capability of thirty two (32) amps. The supply is controlled by a Yokogawa model UT450E temperature controller that senses the temperature of the cold plate in zone two (2) with a thermocouple.

A flow meter, Cole-Parmer 32466-50, is in the cooling water circuit to measure coolant loop flow rate.

Additional recorded thermocouples are used for ambient temperature, first stage plate temperature, intraplate temperature next to the cassette in the second zone and the temperature of the center of the fourth liquid heat sink in a series set in zone two.

Coolant flow rate, TEC current and TEC voltage were measured and recorded manually at times during each test run.

Design and Performance calculations for TE cooling

Objective: Cool blood from 37°C to 6°C at a flow rate of 500 ml/min.

Given:

- Heat load (Q_b) that must be removed from the blood = 980 Watts.
- Mass flow rate (m_b) of the blood for 500 ml/min = 29.948 kg/hr.
- TEC's of choice = CP5-31-06L
 - $Q_{max} = 125$ Watts
 - $\Delta T_{max} = 67^\circ\text{C}$
 - $I_{max} = 60$ amps
- Eight (8) TEC's fit on one (1) cooling plate.
- There will be one (1) liquid heat exchanger per TEC.

Assumptions:

- TEC is run at 50% of power, therefore; $I = 30$ amps

Problem: Heat pumped at cold surface (Q_c) for different temperatures (one TEC).

Given:

- Number of thermocouples (N) = 31
- Seebeck Coefficient (α) = 0.000202 volts/K
- Current (I) = 30 amps
- Cold side temperature (T_c) = 271 K
- Resistivity (ρ) = 0.00101 ohm-cm
- Area/Length of T.E. Element (G) = 1.196 cm
- Thermal conductivity (k) = 0.0151 W/cm-K

Equation:

$$Q_c = 2N [\alpha I T_c - ((I^2 \rho) / (2 G)) - k \Delta T G]$$

$$Q_c = 2 (31) [(0.000202 * 30 * 271) - ((30^2 * 0.00101) / (2 * 1.196)) - (0.0151 * 30 * 1.196)]$$

$$Q_c = 62 [1.64226 - (0.909 / 2.392) - .5454]$$

$$Q_c = 62 [0.7168]$$

Solution:

$$Q_{c-2} = 44.44 \text{ Watts (cold side temp. of } -2^\circ\text{C)}$$

$$Q_{c-5} = 40.18 \text{ Watts (cold side temp. of } -5^\circ\text{C)}$$

$$Q_{c-10} = 32.70 \text{ Watts (cold side temp. of } -10^\circ\text{C)}$$

Problem: Heat pumped at cold surface (Q_t) using 32 TEC's at different temperatures.

Given:

- $Q_{c-2} = 44.44$ Watts (cold side temp. of -2°C)
- $Q_{c-5} = 40.18$ Watts (cold side temp. of -5°C)
- $Q_{c-10} = 32.70$ Watts (cold side temp. of -10°C)

Equation:

$$Q_t = 32 (Q_c)$$

$$Q_t = 32 * 44.44$$

Solution: $Q_{t-2} = 1422.08$ Watts (cold side temp. of -2°C)
 $Q_{t-5} = 1285.76$ Watts (cold side temp. of -5°C)
 $Q_{t-10} = 1046.40$ Watts (cold side temp. of -10°C)

Problem: Voltage (V) needed to run one (1) TEC at different temperatures.

Given:

- Number of thermocouples (N) = 31
- Seebeck Coefficient (α) = 0.000202 volts/K
- Current (I) = 30 amps
- Resistivity (ρ) = 0.00101 ohm-cm
- Area/Length of T.E. Element (G) = 1.196 cm

Equation: $V = 2N [(I\rho) / G] + (\alpha \Delta T)$
 $V = 2 (31) [((30 * 0.00101) / 1.196) + (0.000202 * 30)]$
 $V = 62 [(0.0303 / 1.196) + 0.00606]$

Solution: $V = 62 [0.0314]$
 $V_{-2} = 1.946$ volts (cold side temp. of -2°C)
 $V_{-5} = 1.982$ volts (cold side temp. of -5°C)
 $V_{-10} = 2.045$ volts (cold side temp. of -10°C)

Problem: Voltage (V_t) needed to run 32 TEC's at different temperatures.

Given:

- $V_{-2} = 1.946$ volts (cold side temp. of -2°C)
- $V_{-5} = 1.982$ volts (cold side temp. of -5°C)
- $V_{-10} = 2.045$ volts (cold side temp. of -10°C)

Equation: $V_t = 32 (V)$
 $V_t = 32 * 1.946$

Solution: $V_{t-2} = 62.27$ volts (cold side temp. of -2°C)
 $V_{t-5} = 63.42$ volts (cold side temp. of -5°C)
 $V_{t-10} = 65.44$ volts (cold side temp. of -10°C)

Problem: Coefficient of Performance (COP) for one (1) TEC at different temperatures.

Given:

- $Q_{c-2} = 44.44$ Watts (cold side temp. of -2°C)
- $Q_{c-5} = 40.18$ Watts (cold side temp. of -5°C)
- $Q_{c-10} = 32.70$ Watts (cold side temp. of -10°C)
- $V_{-2} = 1.946$ volts (cold side temp. of -2°C)
- $V_{-5} = 1.982$ volts (cold side temp. of -5°C)
- $V_{-10} = 2.045$ volts (cold side temp. of -10°C)
- Current (I) = 30 amps

Equation: $COP = Q_c / (I V)$

$$COP = 44.44 / (30 * 1.946)$$

Solution: **$COP_{-2} = 0.76$ (cold side temp. of $-2^{\circ}C$)**
 $COP_{-5} = 0.68$ (cold side temp. of $-5^{\circ}C$)
 $COP_{-10} = 0.53$ (cold side temp. of $-10^{\circ}C$)

Problem: Heat rejected (Q_r) from one (1) TEC at different temperatures.

Given:

- $Q_{c-2} = 44.44$ Watts (cold side temp. of $-2^{\circ}C$)
- $Q_{c-5} = 40.18$ Watts (cold side temp. of $-5^{\circ}C$)
- $Q_{c-10} = 32.70$ Watts (cold side temp. of $-10^{\circ}C$)
- $V_{-2} = 1.946$ volts (cold side temp. of $-2^{\circ}C$)
- $V_{-5} = 1.982$ volts (cold side temp. of $-5^{\circ}C$)
- $V_{-10} = 2.045$ volts (cold side temp. of $-10^{\circ}C$)
- Current (I) = 30 amps

Equation: $Q_r = Q_c + (I V)$

$$Q_r = 44.44 + (30 * 1.946)$$

Solution: **$Q_{r-2} = 102.82$ Watts (cold side temp. of $-2^{\circ}C$)**
 $Q_{r-5} = 99.64$ Watts (cold side temp. of $-5^{\circ}C$)
 $Q_{r-10} = 94.05$ Watts (cold side temp. of $-10^{\circ}C$)

Problem: Total heat rejected (Q_{tr}) from all 32 TEC's at different temperatures.

Given:

- $Q_{r-2} = 102.82$ Watts (cold side temp. of $-2^{\circ}C$)
- $Q_{r-5} = 99.64$ Watts (cold side temp. of $-5^{\circ}C$)
- $Q_{r-10} = 94.05$ Watts (cold side temp. of $-10^{\circ}C$)

Equation: $Q_{tr} = 32 (Q_r)$

$$Q_{tr} = 32 * 102.82$$

Solution: **$Q_{tr-2} = 3290.24$ (cold side temp. of $-2^{\circ}C$)**
 $Q_{tr-5} = 3188.48$ (cold side temp. of $-5^{\circ}C$)
 $Q_{tr-10} = 3009.60$ (cold side temp. of $-10^{\circ}C$)

Cooling load calculations

Problem: Heat load (Q) that must be removed from blood (*assuming water*).

Given:

- Flow Rate = 500 ml/min
- Fluid entry temp. = $37^{\circ}C = 98.6^{\circ}F$
- Fluid exit temp. = $6^{\circ}C = 42.8^{\circ}F$
- Specific heat capacity of water (c) = 1.000 Btu/(lb- $^{\circ}F$) **Assume water for blood**

Equation: $Q = wc \Delta T$

w = weight flow rate (lb/hr)

$$w = .5 \text{ L/min} * 0.2642 \text{ gal/L} * 60 \text{ min/hr} * 8.33 \text{ lb/gal}$$

$$w = 66.024 \text{ lb/hr}$$

Solution:

$$Q = 66.024 \text{ lb/hr} * 1.000 \text{ Btu/(lb-}^\circ\text{F)} * (98.6 \text{ }^\circ\text{F} - 42.8 \text{ }^\circ\text{F)}$$

$$Q = 66.024 \text{ Btu/(hr-}^\circ\text{F)} * 55.8 \text{ }^\circ\text{F}$$

$$Q = 3684.14 \text{ Btu/hr}$$

$$Q = 1080 \text{ Watts}$$

Given:

- Specific heat capacity of *blood* (c) = 3.8 J/(g-°C)
- Density of *blood* (ρ) = 1060 kg/m³

- Specific heat capacity of *water* (c) = 4.18 J/(g-°C)
- Density of *water* (ρ) = 1000 kg/m³

Problem: Heat load (Q) that must be removed from *blood*.

Given:

- Flow Rate = 500 ml/min
- Fluid entry temp. = 37 °C = 98.6 °F
- Fluid exit temp. = 6 °C = 42.8 °F
- Specific heat capacity of *blood* (c) = 3.8 J/(g-°C)

Equation:

$$Q = wc \Delta T$$

w = weight flow rate (lb/hr)

$$w = .5 \text{ L/min} * 0.2642 \text{ gal/L} * 60 \text{ min/hr} * 8.33 \text{ lb/gal}$$

$$w = 66.024 \text{ lb/hr} = 29.948 \text{ kg/hr}$$

Solution:

$$Q = 29.948 \text{ kg/hr} * 1.0556 \text{ (W-hr)/(kg-}^\circ\text{C)} * (37 \text{ }^\circ\text{C} - 6 \text{ }^\circ\text{C)}$$

$$Q = 31.613 \text{ W/}^\circ\text{C} * 31 \text{ }^\circ\text{C}$$

$$Q = 980 \text{ Watts}$$

$$Q = 3343.92 \text{ Btu/hr}$$

Calculations for 1/8" and 1/4" ID Tubing

Problem: Mean velocity (u) of blood thru a *1/8" ID* tube.

Given:

- Mass flow rate (m) = 29.948 kg/hr
- Density of blood (ρ) = 1060 kg/m³
- Cross sectional area of tube (A) = .0000079 m²

Equation:

$$m = \rho u A \text{ therefore } u = m/(\rho A)$$

u = mean velocity (m/s)

Solution:

$$u = 29.948 \text{ kg/hr} / (1060 \text{ kg/m}^3 * .0000079 \text{ m}^2)$$

$$u = 3576.30 \text{ m/hr}$$

$$u = 0.99 \text{ m/s}$$

Problem: Mean velocity (u) of blood thru a *1/4" ID* tube.

Given:

- Mass flow rate (m) = 29.948 kg/hr
- Density of blood (ρ) = 1060 kg/m³
- Cross sectional area of tube (A) = .000032 m²

Equation: $m = \rho u A$ therefore $u = m/(\rho A)$

u = mean velocity (m/s)

Solution: $u = 29.948 \text{ kg/hr} / (1060 \text{ kg/m}^3 * .000032 \text{ m}^2)$

$u = 882.90 \text{ m/hr}$

$u = 0.25 \text{ m/s}$

Problem: Reynolds number (Re) for blood flow thru **1/8" ID** and **1/4" ID** tube.

Given:

- Diameter of tube 1/8" ID (D) = .0032 m
- Diameter of tube 1/4" ID (D) = .0064 m
- Density of blood (ρ) = 1060 kg/m³
- Mean velocity (u) = .99 m/s
- Viscosity of blood (μ) = .004 kg/(m-s)

Equation: $Re = (\rho u D)/\mu$

Solution: $Re = (1060 \text{ kg/m}^3 * .99 \text{ m/s} * .0032 \text{ m}) / .004 \text{ kg/(m-s)}$

$Re = 839.52$ therefore laminar flow conditions exist (1/8" ID tube)

$Re = 420.69$ (1/4" ID tube)

Problem: Convection heat transfer coefficient (h) for blood flow thru **1/8" ID** and **1/4" ID** tube.

Given:

- Diameter of tube 1/8" ID (D) = .0032 m
- Diameter of tube 1/4" ID (D) = .0064 m
- Thermal conductivity of blood (k) = .492 W/(m-K)
- Constant heat flux (q'')

Equation: $4.36 = (hD)/k$

Solution: $h = (4.36 * k) / D$

$h = (4.36 * .492 \text{ W/(m-k)}) / .0032 \text{ m}$

$h = 670.35 \text{ W/(m}^2\text{-K)}$ (1/8" ID tube)

$h = 337.81 \text{ W/(m}^2\text{-K)}$ (1/4" ID tube)

Problem: Constant heat flux (q'') for blood flow thru **1/8" ID** and **1/4" ID** tube.

Given:

- Convection heat transfer coefficient for 1/8" ID tube (h) = 670.35 W/(m²-K)
- Convection heat transfer coefficient for 1/8" ID tube (h) = 337.81 W/(m²-K)
- Temperature of blood out (T_o) = 6°C

- Temperature of tube surface at blood exit (T_s) = -4°C (assumption, cold side of the TEC is -5°C , 1°C due to conduction thru material)

Equation: $q'' = h*(T_s - T_o)$

Solution: $q'' = 670.35 \text{ W}/(\text{m}^2\text{-K}) * (-4^\circ\text{C} - 6^\circ\text{C})$

$q'' = -6703.5 \text{ W}/\text{m}^2$ (1/8" ID tube)

$q'' = -3378.1 \text{ W}/\text{m}^2$ (1/4" ID tube)

Problem: Length of tube (L) required for cooling blood from 37 to 6°C in 1/8" and 1/4" ID tube.

Given:

- Mass flow rate (m) = 29.948 kg/hr
- Heat flux for 1/8" ID (q'') = $-6703.5 \text{ W}/\text{m}^2$
- Heat flux for 1/4" ID (q'') = $-3378.1 \text{ W}/\text{m}^2$
- Diameter of tube 1/8" ID (D) = .0032 m
- Diameter of tube 1/4" ID (D) = .0064 m
- Specific heat capacity of blood (c) = 3800 J/(kg- $^\circ\text{C}$)
- Temperature of blood in (T_i) = 37°C
- Temperature of blood out (T_o) = 6°C

Equation: $L = ((mc) / (\pi D q'')) * (T_o - T_i)$

Solution: $L = ((29.948 \text{ kg/hr} * 3800 \text{ J}/(\text{kg}\text{-}^\circ\text{C})) /$

$(\pi * .0032 \text{ m} * -6703.5 \text{ W}/\text{m}^2)) * (6^\circ\text{C} - 37^\circ\text{C})$

$L = ((113802.4 \text{ J}/(\text{hr}\text{-}^\circ\text{C}) * .0002777778 \text{ (W-hr)/J}) / -67.39 \text{ W/m}) * -31^\circ\text{C}$

L = 14.5 m (1/8" ID tube, q'' around full diameter)

L = 14.4 m (1/4" ID tube, q'' around full diameter)

Problem: Heat rate (Q) on 14.5 m of tubing, 1/8" ID, one side.

Given:

- Heat flux for 1/8" ID (q'') = $-6703.5 \text{ W}/\text{m}^2$
- Area of tubing, one side (A) = $.0747 \text{ m}^2$

Equation: $Q = q''A$

Solution: $Q = -6703.5 \text{ W}/\text{m}^2 * .0747 \text{ m}^2$

Q = 500 W

Problem: Thermal performance needed from the liquid to air heat exchanger.

Given:

- Heat (Q_T) = 5000 Watts (heat load 1000 Watts plus Tec generated heat 4000 Watts)
- Nominal temperature difference (ΔT) at 1 GPM flow rate = 14°C

Equation: $C = Q_T/\Delta T$

Solution: $C = 5000 \text{ W} / 14^\circ\text{C}$

$C = 357 \text{ W}^\circ\text{C}$

Calculations for Non-circular Coolant Path (assume 1.0" x 0.063")

Problem: Fluid channel area (A).

Given:

- Width of channel (W) = 1.0" = 0.0254m
- Height of channel (H) = 0.063" = 0.0016m

Equation: $A = WH$

Solution: $A = 0.0254\text{m} * 0.0016\text{m}$

$A = 0.000041\text{m}^2$

Problem: Fluid surface perimeter (P).

Given:

- Width of channel (W) = 1.0" = 0.0254m
- Height of channel (H) = 0.063" = 0.0016m

Equation: $P = 2 * (W + H)$

Solution: $P = 2 * (0.0254\text{m} + 0.0016\text{m})$

$P = 2 * 0.027\text{m}$

$P = 0.054\text{m}$

Problem: Hydraulic diameter (D_h).

Given:

- Fluid channel area (A) = 0.000041m²
- Fluid surface perimeter (P) = 0.054m

Equation: $D_h = (4 * A)/P$

Solution: $D_h = (4 * 0.000041\text{m}^2) / 0.054\text{m}$

$D_h = 0.000164\text{m}^2 / 0.054\text{m}$

$D_h = 0.00304\text{m}$

Problem: Reynolds number (R_e) for 500 ml/min blood flow.

Given:

- Mass flow rate (m) = 29.948 kg/hr
- Viscosity of blood (μ) = 0.004 kg/(m-s)
- Hydraulic diameter (D_h) = 0.00304m

Equation: $R_e = (4 * m) / (\pi * D_h * \mu)$

Solution: $R_e = (4 * 29.948 \text{ kg/hr}) / (\pi * 0.00304\text{m} * 0.004 \text{ kg}/(\text{m}\cdot\text{s}))$
 $R_e = 119.792 \text{ kg/hr} / (0.0000382 \text{ kg/s} * 60 \text{ s/min} * 60 \text{ min/hr})$
 $R_e = 199.792 \text{ kg/hr} / .1375 \text{ kg/hr}$
 $R_e = 1453$ (Laminar Flow)

Problem: Nusselt number (N_u).

Given:

- Fully developed laminar flow (R_e) = 1453
- Cross section ratio of blood flow (C_r) = 16
- Uniform heat flux along blood flow (q'')

Equation: See Table 8.1 on page 501 of Fundamentals of Heat and Mass Transfer

Solution: **$N_u = 8.23$**

Problem: Convection heat transfer coefficient (h) for blood flow thru channel.

Given:

- Nusselt number (N_u) = 8.23
- Hydraulic diameter (D_h) = 0.00304m
- Thermal conductivity of blood (k) = .492 W/(m-K)

Equation: $h = (N_u * k) / D_h$

Solution: $h = (8.23 * .492 \text{ W}/(\text{m}\cdot\text{K})) / 0.00304\text{m}$
 $h = 1332 \text{ W}/(\text{K}\cdot\text{m}^2)$

Problem: Constant heat flux (q'') for blood flow thru channel.

Given:

- Convection heat transfer coefficient (h) = 1332 W/(K-m²)
- Temperature of blood out (T_o) = 6°C
- Temperature of tube surface at blood exit (T_s) = -4°C (*assumption, cold side of the TEC is -5°C, 1°C due to conduction thru material*)

Equation: $q'' = h (T_s - T_o)$

Solution: $q'' = 1332 \text{ W}/(\text{K}\cdot\text{m}^2) * (-4^\circ\text{C} - 6^\circ\text{C})$
 $q'' = -13320 \text{ W}/\text{m}^2$

Problem: Length of channel (L_c) required for cooling blood from 37 to 6°C.

Given:

- Mass flow rate (m) = 29.948 kg/hr
- Heat flux (q'') = -13320 W/m²
- Channel perimeter (P_c) = 0.054m

- Specific heat capacity of blood (c) = 3800 J/(kg-°C)
- Temperature of blood in (T_i) = 37°C
- Temperature of blood out (T_o) = 6°C

Equation: $L_c = ((mc) / (P_c q'')) * (T_o - T_i)$

Solution: $L_c = ((29.948 \text{ kg/hr} * 3800 \text{ J/(kg-°C)}) /$
 $(0.054 \text{ m} * -13320 \text{ W/m}^2)) * (6^\circ\text{C} - 37^\circ\text{C})$

$$L_c = ((113802.4 \text{ J/(hr-°C)} * .00027777778 \text{ (W-hr)/J}) / -719.28 \text{ W/m}) * -31^\circ\text{C}$$

$$L_c = 1.4 \text{ m}$$

Problem: Heat rate (Q_c) on 1.4m of channel, one side.

Given:

- Heat flux for channel (q'') = -13320 W/m²
- Area of channel, one side (A_c) = 0.0378m²

Equation: $Q_c = q'' A_c$

Solution: $Q_c = -13320 \text{ W/m}^2 * .0378 \text{ m}^2$

$$Q_c = 503 \text{ W}$$

Calculations for Proposed Heat Sink (forced convection and liquid cooled)

Problem: Heat load (Q_{HS}) removed by one (1) 8" x 4" heat sink at 34°C and 47°C.

Given:

- Thermal resistance for 8" x 4" heat sink w/ (2) 45 CFM fans (TR_{45}) = 0.10°C/W
- Heat sink temperature (T_1) = 34°C or 47°C
- Ambient temperature (T_2) = 21°C

Equation: $Q_{HS} = (T_1 - T_2) / TR_{45}$

Solution: $Q_{HS} = (34^\circ\text{C or } 47^\circ\text{C} - 21^\circ\text{C}) / 0.10^\circ\text{C/W}$

$$Q_{HS} = 13^\circ\text{C or } 26^\circ\text{C} / 0.10^\circ\text{C/W}$$

$$Q_{HS} = 130 \text{ Watts (1) Heat Sink; } 780 \text{ Watts (6) Heat Sinks @ } 34^\circ\text{C}$$

$$Q_{HS} = 260 \text{ Watts (1) Heat Sink; } 1560 \text{ Watts (6) Heat Sinks @ } 47^\circ\text{C}$$

Problem: Thermal performance needed from the liquid to air heat exchanger.

Given:

- Heat (Q_T) = 1700 Watts (heat load 1000 Watts plus Tec generated heat 2260 Watts minus 1560 Watts from (12) forced convection heat sinks)
- Nominal temperature difference (ΔT) at 1 GPM flow rate = 9°C
- TEC hot side temp = 34°C
- Heat pumped at cold surface = 500 Watts

Equation: $C = Q_T / \Delta T$

Solution: $C = 1700 \text{ W} / 9^\circ\text{C}$

$C = 188 \text{ W}/^\circ\text{C}$

Problem: Thermal performance needed from the liquid to air heat exchanger.

Given:

- Heat (Q_T) = 3152 Watts (heat load 1340 Watts plus Tec generated heat 5272 Watts minus 3120 Watts from (12) forced convection heat sinks)
- Nominal temperature difference (ΔT) at 1 GPM flow rate = 21°C
- TEC hot side temp = 47°C
- Heat pumped at cold surface = 670 Watts

Equation: $C = Q_T / \Delta T$

Solution: $C = 3152 \text{ W} / 21^\circ\text{C}$

$C = 150 \text{ W}/^\circ\text{C}$

Calculations for Non-circular Coolant Path (Gaymar Disposable .90" x 0.042")

Problem: Fluid channel area (A).

Given:

- Width of channel (W) = $0.90'' = 0.02286\text{m}$
- Height of channel (H) = $0.042'' = 0.00107\text{m}$

Equation: $A = WH$

Solution: $A = 0.02286\text{m} * 0.00107\text{m}$

$A = 0.0000245\text{m}^2$

Problem: Fluid surface perimeter (P).

Given:

- Width of channel (W) = $0.90'' = 0.02286\text{m}$
- Height of channel (H) = $0.042'' = 0.00107\text{m}$

Equation: $P = 2 * (W + H)$

Solution: $P = 2 * (0.02286\text{m} + 0.00107\text{m})$

$P = 2 * 0.02393\text{m}$

$P = 0.04786\text{m}$

Problem: Hydraulic diameter (D_h).

Given:

- Fluid channel area (A) = 0.0000245m²
- Fluid surface perimeter (P) = 0.04786m

Equation: $D_h = (4 * A)/P$

Solution: $D_h = (4 * 0.0000245m^2) / 0.04786m$

$D_h = 0.000098m^2 / 0.04786m$

$D_h = 0.00205m$

Problem: Reynolds number (R_e) for 500 ml/min blood flow.

Given:

- Mass flow rate (m) = 29.948 kg/hr
- Viscosity of blood (μ) = 0.004 kg/(m-s)
- Hydraulic diameter (D_h) = 0.00205m

Equation: $R_e = (4 * m) / (\pi * D_h * \mu)$

Solution: $R_e = (4 * 29.948 \text{ kg/hr}) / (\pi * 0.00205m * 0.004 \text{ kg/(m-s)})$

$R_e = 119.792 \text{ kg/hr} / (0.00002576 \text{ kg/s} * 60 \text{ s/min} * 60 \text{ min/hr})$

$R_e = 199.792 \text{ kg/hr} / .09274 \text{ kg/hr}$

$R_e = 1292 \text{ (Laminar Flow)}$

Summary of Data and Results

A total of ten test runs were completed with the TE cooling system. A summary of the results is shown in Table 1.

Test #	Fluid dT	TEC volts	TEC amps	TEC watts	watts cooling	COP	Note
1	22.5	33.9	32.0	1085	783	0.72	single zone; plate=6.2
2	31.4	66.0	30.0	1980	1093	0.55	test to determine set point
3	0.0	27.0	10.0	270	0	0.00	minimal cooling load test; no flow
4	29.8	49.0	22.0	1078	1037	0.96	set pt = 0
	31.6	65.0	30.0	1950	1100	0.56	set pt = -3.5
5	30.7	73.0	32.0	2336	1068	0.46	one heat exchanger; not stable
6	31.1	72.0	32.0	2304	1082	0.47	plate = -2.3; simulate 90F ambient
7	30.3	49.0	22.0	1078	1054	0.98	set pt = 0
	31.3	73.0	32.0	2336	1089	0.47	set pt = -3.5; eight series
8	29.4	57.0	25.0	1425	1023	0.72	set pt = 0
	30.9	72.6	31.5	2287	1075	0.47	plate = -2.4; 32 parallel
9	31.0	56.0	25.0	1400	1079	0.77	set pt = 0; increased circulation
	32.8	70.0	32.0	2240	1141	0.51	plate = -2.6
10	31.4	47.0	23.0	1081	1093	1.01	set pt = 0
	33.8	67.0	30.0	2010	1176	0.59	set pt = -3.5; four series

Table 1

The fluid cooling in Table 1 (column two) is shown as temperature difference between the inlet and outlet of the cassette because the inlet temperature varies from 37 to 40C depending on test conditions. Fluid temperature difference is a more consistent performance measurement than outlet temperature. A fluid delta T of 27C would meet the minimum cooling requirement to cool the blood from 37C to 10C. All tests except one and three meet this requirement. Test one was done to measure the cooling capability of a single zone and one cassette. This cassette has superior heat exchanger properties compared to the round tubing used in the first TEC device, but a single cassette cannot provide enough cooling at the desired flow rate. The two-cassette configuration provides more than enough fluid cooling. It is possible that a custom designed cassette with larger overall area or improved flow pattern with more turbulent flow would provide enough cooling in a single cassette.

The significant variation between these tests is the TEC watts input and the resulting COP (coefficient of performance), which is a measure of efficiency. A coefficient of one (1) means one watt of heat transferred for one (1) watt power input. Most test were started with a zone two plate temperature of zero (0) degrees and after the fluid output temperature had stabilized, the plate temperature was lowered to -3.5C to obtain a fluid out temperature of six (6) degrees as this is considered a worst case cooling requirement. The input power to the TEC almost doubles in trying to obtain the lower temperature and the increase in cooling is small. The performance calculations for the TE modules do not predict such a large decrease in heat pumping capacity with lower cold side temperatures. What appears to be happening is that the hot side is getting much hotter than predicted because the liquid heat sinks cannot remove enough heat from the hot side of the TE modules. This is similar to what happened in the first device where the hot side heat was directed to the center of the assembly and could not be adequately removed. This second device is more efficient, but heat removal from the hot side is still limiting performance.

Test number five was run with only one liquid to air heat exchanger. Hot side cooling was inadequate and temperatures did not stabilize over the normal test time of 20 to 30 minutes. The second liquid to air heat exchanger was reinstalled for the remaining tests.

Test number six is similar to test four except that the fans cooling the liquid to air heat exchangers were reduced in speed until the cooling water returning to the liquid heat sinks was 34C (93F) to simulate operation in warm ambient conditions. The controller could not maintain the plate set point temperature of -3.5C under these conditions and the plate warmed up to -2.3C. The COP dropped from 0.56 to 0.47.

Tests seven thru ten measured the performance of different hot side cooling connections.

Test number ten (10) shows the best COP. This test had the highest cooling water flow rate through the liquid heat sinks which results in the best heat removal from the TE module hot side. Table 2 shows the correlation between COP at 0 degree C plate temperature and flow rate in each liquid heat sink. The total flow rate is measured by a flow meter inserted in the cooling loop. The flow in each heat sink is calculated by dividing the total flow by the number of parallel connections between the input and output cooling manifolds. This assumes equal flow in each parallel connection, which is reasonable because the manifolds are large in diameter compared to the parallel connection tubing and each parallel path is approximately the same length.

Coolant Flow Rate in Liquid Heat Sink - Calculated

Test #	Total Flow gpm	# in series	# parallel	Heat sink gpm	COP
2 to 7	2.3	8	4	0.575	0.98
8	3.4	1	32	0.106	0.72
9	5.75	1	32	0.18	0.77
10	4.9	4	8	0.613	1.01

Table 2

Thermoelectric cooling with significant heat pumping capacity requires a large power supply because, in most cases, the COP will be less than one. The supply used in this test had a maximum current of 32 amps. The calculated optimum

design current for this model TE module and this application is 40 amps. We were not able to run the TEC assembly at 40 amps, but there are indications that the heat removal would be inadequate at this current.

Another consideration is total power requirements. The maximum power capability of a standard 120 volt wall outlet is about 1500 watts. If a device needs more than this then a 220 volt outlet is required. The power supply used for this test runs on 208 volt three phase power. A device that runs on 120 volt power could be used almost anywhere, but 220 volt and three phase outlets may not be readily available.

Conclusions

This thermoelectric cooling hypothermia device meets the basic cooling requirements. Most of the suggestions for further work outlined in Technical Report TR_Hypo 020822 WN.DOC were implemented in this device and performance was improved. However, the system in its present form is too large, too heavy and can consume too much electrical power to be useful outside the laboratory. More thermal and mechanical design improvements are necessary for a practical device.

Suggestions for Further Work

Results from this technical report suggest that we look into evaluating this same design with a higher-powered power supply so that the TEC may be tested at the calculated optimum operating current.

The thermal resistance between the fluid (blood) in the cassette bag and the cold plate should be lower.

Hot side heat sinking and heat removal should be improved.

Use one larger cassette instead of two.

Reduce size and weight of overall assembly

Optimize design and performance for operation with 120 volt power.

APPENDIX N

TECHNICAL REPORT

#TECHRP REV. D

**RECORD #
280**

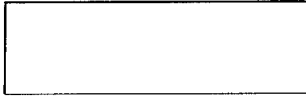

TITLE TEC Cooling Device Performance as a Function of Input Power		FILENAME TR_Hypo 0209020CR	REVISION 00
PROJECT OR PROGRAM NAME Mild to Moderate Hypothermia Device		PROGRAM ROOT NUMBER 78	
PROGRAM TASK DESCRIPTION TEC Cooling Method		PROGRAM TASK NUMBER 00	
NAME Charles Rapach		DEPARTMENT Program Management	DATE 9/20/02
TECHNICAL AREA Design Verification			
SUBJECT AND KEY TECHNICAL WORDS Hypothermia, Thermoelectric Coolers (TEC), performance, power supply			
DOCUMENTATION TYPE			
<input type="checkbox"/> Validation	<input type="checkbox"/> Error Budget	<input type="checkbox"/> Reliability	<input type="checkbox"/> Sensitivity
<input checked="" type="checkbox"/> Verification	<input type="checkbox"/> Product Support	<input type="checkbox"/> Risk Analysis	<input type="checkbox"/> Other
ASSOCIATED REPORTS TR_Hypo 020822 WN, TR_Hypo 020903 SN			

Abstract

This report presents test results of an improved thermoelectric cooling prototype device for the mild to moderate hypothermia requirements. An earlier report, TR_Hypo 020903 SN.doc, indicated that the device can meet the cooling requirements under most conditions. The previous tests were run with a power supply that could not run the device at its maximum rated power. The tests described here were run with a larger power supply and tested the device over a larger current range. The results show that the device, in its present form, operates most efficiently at the lower power settings.

Background

The Hypothermia Program is a research and development program funded by the Department of the Army in cooperation with Safar Research Institute in Pittsburgh, PA. The proposed device will cool the human body's core temperature between 36°C to 32°C putting it into a state of mild to moderate hypothermia. This will be done by externally (veno-venous or arterio-arterial) cooling the blood from 37°C (normal body temperature) to a target of 10°C at a flow rate of about 500 ml/min. Initially, this device is to be used in a hospital emergency room environment with sufficient electrical power supply and space. However, future consideration must be given to develop a device that is portable by one individual and self-supportive from its own electrical power supply. Therefore, size, weight and overall efficiency of the device is an ongoing issue.

Introduction

The previous test of the one and two zone thermoelectric cooling (TEC) assembly was done with a power supply that was limited to thirty two (32) amps. The calculated optimum current is forty (40) amps and the TE modules used in the device have a maximum rating of 60 amps. Although the cooling performance was adequate with the smaller supply, there is some question weather cooling could be improved with more input power. A larger power supply has been obtained and will be used to test the device over its full operating power range.

Purpose

Test the present TEC hypothermia device over a range of operating current to determine the best operating conditions.

Description of Apparatus and Setup

The setup is similar to test number ten described in Technical Report TR_Hypo 020903 SN except for the power supply used to power the TEC. For this test an Electronics Measurements Inc Model TCR 160T80-1-D power supply is used. This supply uses 240 volt three phase input power and can supply 160 volts at 80 amps. The cold plate temperature is not controlled, but stabilizes at a temperature determined by the current drive to the TEC and the cooling load from the warm fluid (water) simulating blood.

For each test, the supply is set to several fixed current levels and the system parameters are recorded while the TEC stabilizes. The one zone and two zone configurations were tested separately. The maximum power available from the wall outlet was 30 amps at 240 volts three phase. This limited the power supply output setting to 50 amps for the one zone test and 45 amps for the two zone test. The maximum current available was above the calculated optimum in both cases and was high enough to characterize the TEC assembly performance. The current value was read from the digital meter on the supply and voltage was measured at the TEC input terminals to compensate for voltage drop in the wiring from the supply to the TEC terminals.

Summary of Data and Results

The results are summarized in Table 1 below. Three separate tests were run. In each test the current was increased in five amp steps from a starting value and the system was allowed to stabilize at each current level. A single zone was tested in test one with 30 to 50 amps input current. One zone does not provide enough cooling, but this information helps characterize the TEC assembly. Note that fluid delta T increases only 1.7 degrees as TEC input power increases almost three times.

Test two and three are done with a two zone configuration. Test three was done at lower current levels after it was seen that performance was always decreasing with increasing current. There is some gain in fluid delta T (4.4degrees) by increasing the current from 25 to 45 amps, but it requires much more input power. Operating below 25 amps provides the required cooling and enables the assembly to operate on power available from a standard 120 volt outlet.

In all cases, as shown in Table 1, coefficient of performance (COP) decreases with increasing current. The most efficient operating condition is then the current that just meets the cooling requirement.

Test #	Fluid dT	TEC volts	TEC amps	TEC watts	watts cooling	COP	Note
1	21.8	31.6	30	948	759	0.80	single zone
	22.7	37.4	35	1309	790	0.60	
	23.0	42.8	40	1712	800	0.47	
	23.6	49.0	45	2205	821	0.37	
	23.5	55.0	50	2750	818	0.30	
3	20.9	21.6	10	216	727	3.37	two zone
	23.9	32.9	15	494	832	1.69	
	27.9	44.1	20	882	971	1.10	
	30.0	56.0	25	1400	1044	0.75	
2	33.6	66.2	30	1986	1169	0.59	two zone
	34.1	78.0	35	2730	1187	0.43	
	35.1	90.1	40	3604	1221	0.34	
	34.4	103.3	45	4649	1197	0.26	

Table 1.

Conclusions

Increasing the operating current yielded little or no gain in performance compared to the previous test. The device operates most efficiently at the minimum current that provides adequate cooling.

Suggestions for Further Work

Possible improvements are outlined in the associated referenced reports.

APPENDIX O

TECHNICAL REPORT

#TECHRP REV. D

**RECORD #
278**

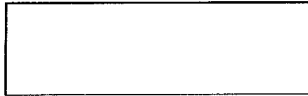

TITLE Characterization of Dometic portable refrigerator/freezer - Propane		FILENAME TR_Hypo 020909DF.doc	REVISION 00
PROJECT OR PROGRAM NAME Hypothermia Device Research		PROGRAM ROOT NUMBER 78	
PROGRAM TASK DESCRIPTION 20L IV bag cooling methods (Profound Hypothermia)		PROGRAM TASK NUMBER 00	
NAME Dave Felton (test) / Shawn Nesmith (design)		DEPARTMENT Test Engineering	DATE 9/9/02
TECHNICAL AREA Device Characterization			
SUBJECT AND KEY TECHNICAL WORDS Characterization of the cooling capacity of the Dometic brand portable refrigerator/freezer			
DOCUMENTATION TYPE			
<input type="checkbox"/> Validation	<input type="checkbox"/> Error Budget	<input type="checkbox"/> Reliability	<input type="checkbox"/> Sensitivity
<input type="checkbox"/> Verification	<input type="checkbox"/> Product Support	<input type="checkbox"/> Risk Analysis	<input checked="" type="checkbox"/> Other
ASSOCIATED REPORTS TR_Hypo 020828 DF.doc (Dometic 120VAC characterization test)			

Abstract

This report details the results of the characterization tests performed on the Dometic brand "PowerFridge" portable refrigerator/freezer, which is one of the possible candidates to be used on the profound hypothermia project. This report details two (2) propane-fueled tests performed with this freezer. The first test was performed with a 20L bag filled with water, initially at room temperature with the propane flame on the highest setting. The freezer was able to pull the water temperature down to roughly 2°C before the propane was exhausted after about 37 hours. The second test was performed with the 20L bag of water that was prechilled to roughly 3°C with the propane flame on the lowest setting. The propane lasted for over 61 hours and was able to keep the water temperature from going above about 5.7°C.

Background

The Hypothermia Program is a research and development program funded by the Department of the Army in cooperation with Safar Research Institute in Pittsburgh, PA. The proposed device will store large volumes (10 to 40L) of sterile cold flush solution at a temperature of -5 to 5°C . The sterile cold flush solution will be administered to a subject at a delivery rate of about 2 L/min, lowering the core body and brain temperature to around 10 to 20°C causing profound hypothermia. Initially this device is to be used in a hospital emergency room environment with sufficient external power. However, further consideration must be given to develop a device that can be transported by emergency vehicles, such as ambulances and/or helicopters. Therefore, the device will need to have an internal power supply, or operate from the emergency vehicles limited power supply.

Introduction

One of the proposed methods of administering profound hypothermia is to chill a 20L IV bag of sterile cold flush solution to 0°C , which will then be used in a flush of the body's circulatory system at a rate of about 2 L/min. To chill the 20L bag of sterile solution, Biocontrol engineering procured a portable absorption cycle refrigerator/freezer, Model PowerFridge RC3000, from Dometic in LaGrange, IN.

Purpose

The purpose of these tests was to characterize the portable freezer's capability to chill a 20L bag from room temperature down to 0°C and maintain that temperature.

Description of Apparatus and Setup

These two propane characterization tests were run using a full Bernzomatic Net 14.1oz (400g) propane cylinder for each. The Dometic freezer was set up to run in propane mode per the user's manual. No special setup was needed. A Yokogawa MV112 data logger was used to record significant temperatures, which included the ambient temperature inside the freezer, room temperature, the freezer inner evaporator wall temperature, and IV bag water temperature. Figure 1 shows the freezer and the Yokogawa data logger. The IV Bag water temperature was measured using a hypodermic thermocouple inserted into the bag. See Figure 2.

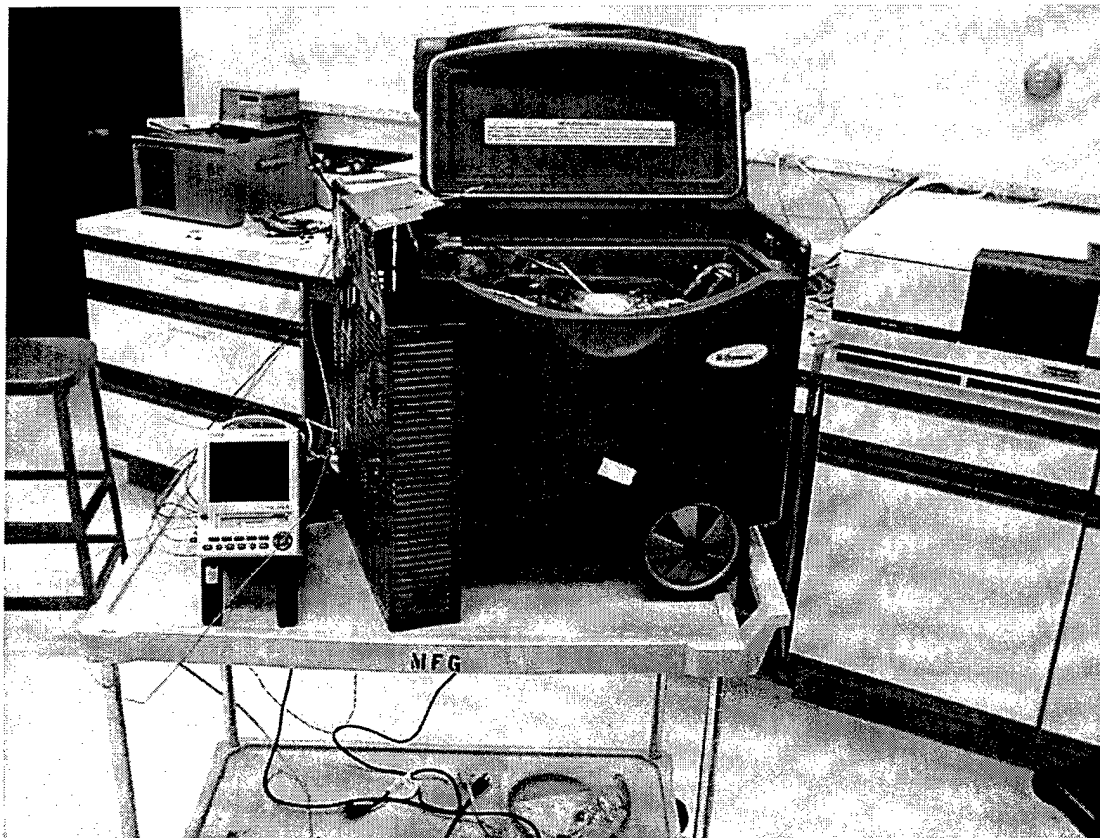

Figure 1

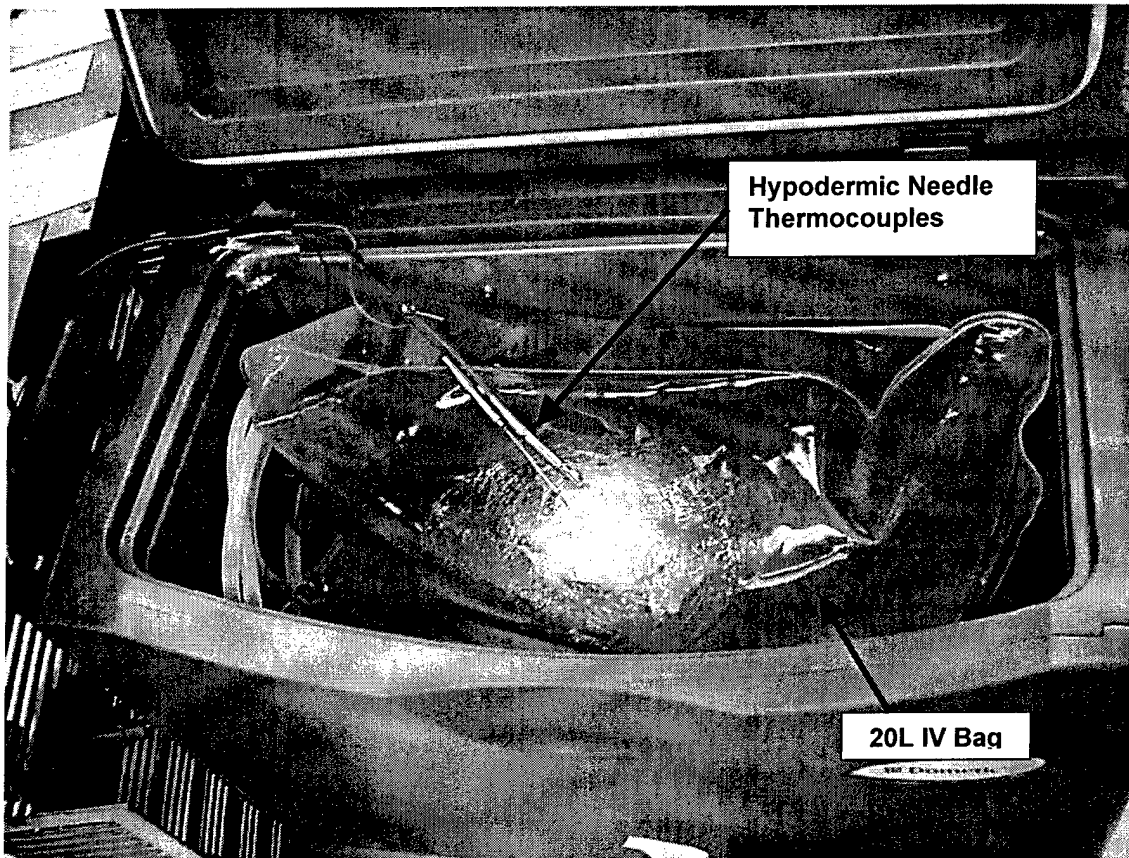

Figure 2

Summary of Data and Results

Test #1

For Test #1, the water in the IV bag started off at room temperature. The propane flame was set to its highest setting to allow for the greatest cooling capacity. Figure 3 shows the results for this test. The propane ran out after about 37 hours. In this time, the IV bag water temperature (purple line) was brought down to about 2°C. The other two lines that follow the water temperature show the freezer inner wall temperature and the freezer inner ambient temperature. The dark blue line shows the room ambient temperature.

Dometic Freezer - Propane Fueled
IV Bag Starting at Room Temp; Flame on Highest Setting

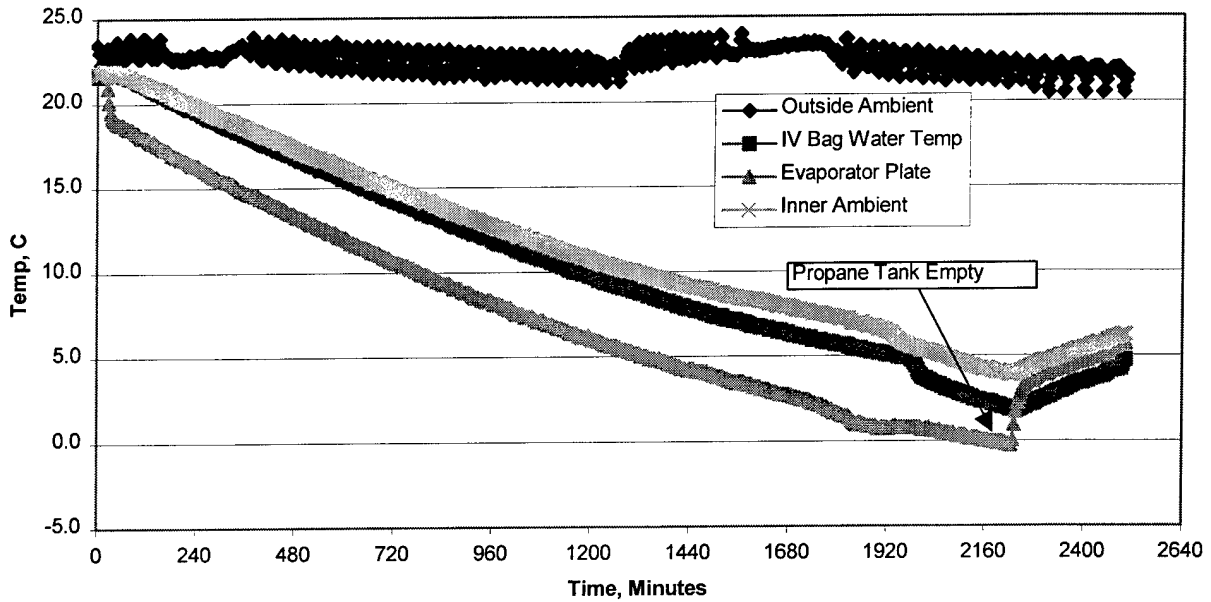

Figure 3

Test #2

The second test was run with the water in the IV bag pre-chilled to roughly 3°C and the propane flame set to the lowest setting. This was run to determine how well and how long the freezer would maintain the temperature. Figure 4 shows the results of this test. The propane lasted for over 61 hours and the temperature was held to under 6°C.

Dometic Freezer - Propane Fueled IV
Bag Pre-Chilled; Flame on Lowest Setting

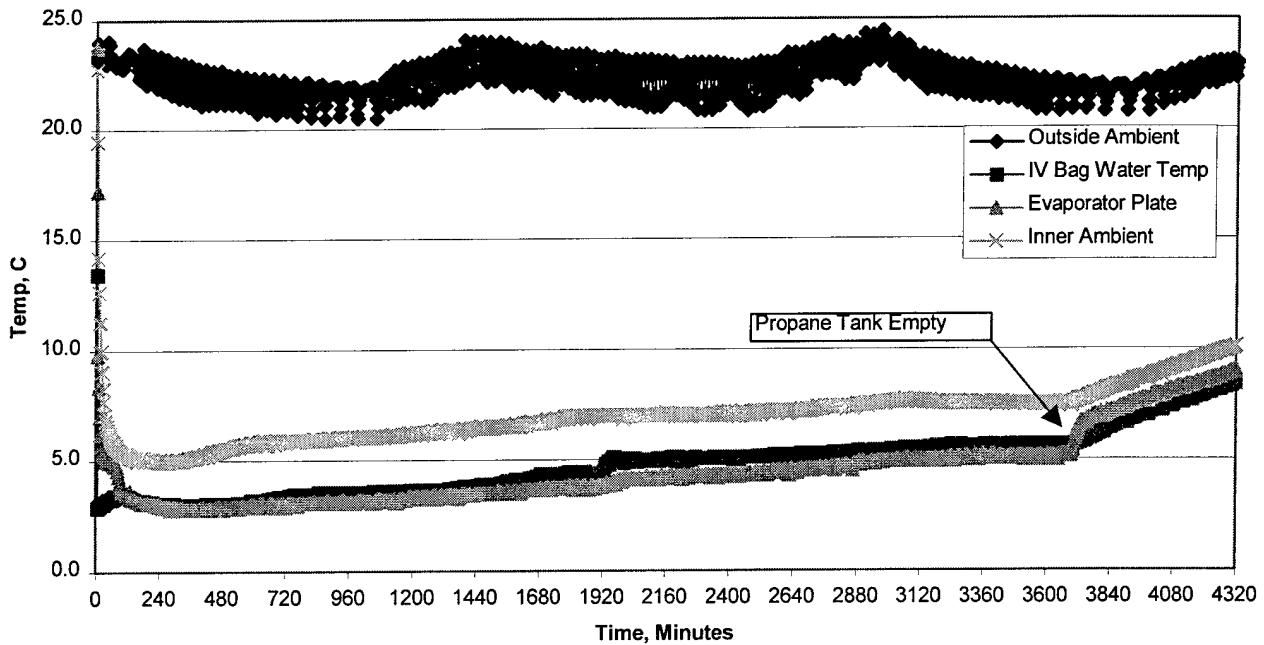

Figure 4

Conclusions

Since this was a characterization test, there are no conclusions to be derived for the recorded data.

Suggestions for Further Work

None

DRD_Mild-Mod Hth
Rev. 0

Mild-Moderate Hypothermia Induction Device
Design Requirements
Program No. 78

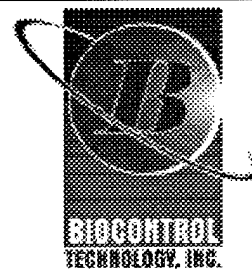

Table of Contents

1.	Product Functional Requirements.....	3
1.1	Maintainability Requirements	3
1.1.1	User Maintenance.....	3
1.2	Operational Requirements.....	3
1.2.1	Physical Description.....	3
1.2.2	Intended Use	3
1.2.3	Operating Modes	3
1.3	Quality Requirements.....	4
1.4	Repairability Requirements	4
2.	Product Performance Requirements.....	5
2.1	Durability Requirements.....	5
2.2	Environmental Requirements	5
2.2.1	Operating.....	5
2.2.2	Shipping and Storage	5
2.3	Performance Requirements.....	5
2.3.1	Design Performance	5
2.3.2	Accessories Performance	6
2.3.3	Physical Performance.....	6
2.3.4	Output Performance.....	6
2.3.5	Device Acceptance Criteria.....	7
2.4	Reliability Requirements.....	7
2.5	Safety Risk Management Requirements.....	7
3.	Product Interface Requirements	8
3.1	Customer Interface Requirements.....	8
3.1.1	Operator Interface.....	8
3.1.2	Patient Interface.....	8
3.2	External Interface Requirements	8
3.3	Labeling Requirements	8
3.4	Service Delivery Requirements	8
4.	Product System and Program Requirements	9
4.1	Business Risk Management Requirements	9
4.2	Customer Service and Product Support Requirements	9
4.3	Financial Requirements.....	9
4.4	Manufacturability Requirements	9
4.5	Manufacturing Requirements	9
4.6	Marketing Requirements	9
4.7	Packaging Requirements	9
4.8	Regulatory Compliance Requirements	9
4.9	Shipping Requirements.....	9
4.10	Standards Compliance Requirements	9
4.11	Statutory Compliance Requirements	9
4.12	Testability Requirements.....	10
5.	References.....	11
6.	Revisions and Updates.....	12

1. Product Functional Requirements

1.1 Maintainability Requirements

1.1.1 User Maintenance

1. The device will have external panels suitable for easy cleaning as appropriate for the surgical theater environment.
2. No routine or scheduled maintenance, other than normal cleaning, will be required for operation of the device.

1.2 Operational Requirements

1.2.1 Physical Description

The device will be a stand-alone product with a pump system, heat exchanger and custom electronics used to cool a patients core body and brain temperature.

1. The device will consist of:
 - A durable framed enclosure containing a heat exchanger, blood pump and custom electronics.
 - A heat exchanger pocket to allow for ease of inserting and removing the blood/fluid heat exchanger.
 - A pump capable of pumping blood/fluid at a preset constant rate and at a preset constant temperature from a patient, through a heat exchanger, and back again to the patient.
 - Simple controls and readouts for easy selection of temperature and flow and monitoring.
2. The device will be operated from a standing position with a simple display and input controls for easy monitoring and adjusting over a reasonable range of operator sizes and positions.
3. The device will be movable with wheels and ease of movement such that a single individual can maneuver it around a hospital and in and out of an elevator. For ease of mobility, the device will:
 - Weigh a maximum of 63.5 kg.
 - Contain lockable swivel casters.

1.2.2 Intended Use

1. Operators will use the device to induce mild to moderate hypothermia (core body and brain temperature to within 34 to 30°C) to patients with blood flow (shock, ongoing CPR, normal blood flow).
2. The device will be of a size that accounts for 95% of the adult population as defined in the AAMI HE 48-1993: Human Factors Engineering and Preferred Practices for Design of Medical Devices.

1.2.3 Operating Modes

1.2.3.1 General

3. The device will operate in the following modes (both modes can be run at the same time):
 - Cold Plate Cooling Mode
 - Blood/Fluid Cooling Mode
4. The operator will determine the mode of operation.
5. Typical operation will consist of:
 - Cooling the cold plates to a predetermined set point temperature and maintaining that temperature.
 - Pumping blood from a patient and cooling it to a preset temperature and re-administering the blood back to the patient. This temperature must also be maintained constant.

1.2.3.2 Cold Plate Cooling Mode

In this mode, the device will pre-cool the cold plates to a preset temperature and maintain that temperature. All temperature control will be adjusted according to the cold plate temperature.

1. The operator will initially turn the unit on.
2. The operator will input the desired out flow temperature of the blood/fluid to the patient.
 - The temperature will be entered from values between 5°C and 37°C.
 - From this temperature input, the set point temperature of the cold plates will be internally calculated.
3. A YSI 400 thermistor will be used to monitor the temperature of the cold plates.
4. Once the cold plates have reached their predetermined set point, the device will maintain that temperature to within +/- 0.5°C.
5. The device will indicate that the cold plates have reached their predetermined temperature.

1.2.3.3 Blood/Fluid Cooling Mode

In this mode, the device will pump blood from the patient through a heat exchanger that will cool the blood to a preset temperature and re-administer the blood back to the patient. All temperature control will be adjusted according to the blood/fluid out flow temperature.

1. The operator will connect the disposable tubing set to the device. This will involve:
 - Inserting the blood/fluid heat exchanger.
 - Attaching the blood/fluid pump.
 - Securing the tubing.
2. The operator will prime the disposable tubing set, heat exchanger and pump with a sterile solution.
3. The operator will select the desired flow rate in which to pump fluid from and to the patient from preset values: 100 ml/min to 500 ml/min at 100 ml/min intervals.
4. The operator will connect the device to the patient via catheters and temperature sensors.
5. The operator will switch the pump on and begin pumping fluid from/to the patient.
6. As the blood/fluid is being pumped back into the patient, the device will maintain the out flow temperature with respect to the device to within +/- 0.5°C.
7. The device will monitor four patient temperatures and display one of them over the range of 30°C to 37°C as selected by the operator.
8. The device will alert the operator if a detected fault arises or if it becomes unable to maintain blood and/or coolant temperature or flow.

1.3 Quality Requirements

1. Quality processes will assure that purchased components meet specifications through the use of inspection instructions.
2. Quality processes will assure that manufactured components meet specifications with first article inspections, inspection instructions and continued statistical sampling.
3. Before shipping, quality assurance will verify that all manufacturing and testing processes were successfully performed on the device.
4. The manufacturing process and quality system will comply with applicable requirements of ISO-9001 and other applicable standards, directives or regulations.

1.4 Repairability Requirements

1. The manufacturer will perform all repairs and service.

2. Product Performance Requirements

2.1 Durability Requirements

1. The device will withstand normal levels of shock and vibration without incurring functional damage. Normal shock and vibration include:
 - Transporting device around a hospital.
 - Loading and unloading of the device into emergency vehicles.
 - Hitting walls and other fixed objects at a walking speed.
2. All exposed surfaces will be resistant to damage from commonly used hospital/clinical cleaning fluids (such as alcohol and 10% bleach), salts, body fluids and glucose solutions.

2.2 Environmental Requirements

2.2.1 Operating

1. Operating Temperature: 15°C to 30°C
2. Non-condensing Humidity: 30% to 75%
3. Altitude: as defined in IEC 601-1

2.2.2 Shipping and Storage

1. Storage Temperature: -35°C to 70°C
2. Storage Pressure: 68 kPa to 106 kPa
3. Storage Relative Humidity: 15% to 95% non-condensing

2.3 Performance Requirements

2.3.1 Design Performance

2.3.1.1 General Operation

1. The device will have a visual indicator light to signal the operator that the device has been turned on.
2. During Plate Cool Down Mode, the device will notify the operator via an indicator light once the cooling plates have reached their predefined set point temperature and will stay on to indicate that the set point temperature is maintained.
3. During Blood/Fluid Cooling Mode, the device will notify the operator that the pump is running properly and pumping at the selected flow rate via an indicator light.
4. An audio alert will sound if there is a malfunction or the temperature and flow rate set points cannot be maintained.

2.3.1.2 Accuracy

5. The device will be capable of cooling blood/fluid at a predetermined flow rate from an in flow temperature of 37°C to a predetermined out flow temperature and maintain that temperature with an accuracy of +/- 0.5°C. The readout accuracy will be +/- 0.2°C over the specified temperature range.
6. The device will be capable of pumping the blood/fluid from/to the patient at a predetermined flow rate with an accuracy of +/- 10% for any selected flow rate.
7. The blood/fluid will be pumped through a 3 meter .25" ID disposable tubing set and heat exchanger. The tubing, heat exchanger and pump must be designed to withstand 138 kPa.
8. The device will monitor four (4) patient temperatures. The patient's temperature readout accuracy will be +/- 0.1°C over the specified range.

2.3.1.3 Electrical Power

1. The device electrical input requirements from an external source are listed below:
 - Line Voltage: 115 volts +/- 10%
 - Line Current: 2 amps maximum.
 - Line Frequency: 60 Hz +/- 3 Hz
2. The device will have a suitable hospital grade power cord.

2.3.2 Accessories Performance

1. Provide four (4) temperature sensor inputs from TSI 400 compatible thermistors to monitor the patient's temperature if required. They will be single use devices (disposable).
2. All tubing sets and blood/fluid heat exchanger will be disposable and have the following features:
 - Tubing clamps located at the inflow and out flow.
 - Ease of priming.
 - A pumping segment compatible with the pump selected.
 - Constructed of clear 0.25" ID medical grade tubing.
 - Biocompatible per ISO 10993-1.
 - Means of easily securing the tubing set and heat exchanger to the device.
 - Clear method of checking for proper installation.
 - Clear and concise method for removal while preventing spillage of any fluids.
 - Provide sterile blood/fluid to the patient.
 - Ease of connecting tubing set to the catheters.

2.3.3 Physical Performance

1. The device will be mobile with a maximum force to initiate movement that complies with the requirements of AAMI HE 48-1993.
2. Incorporate a locking feature to prevent movement when desired.
3. Provide a stable center of gravity to prevent tipping and meet IEC 601-1, Section 24.
4. A standing operator will use the device.
5. Any fluid within the device will be protected from spillage during normal movement around the hospital.

2.3.4 Output Performance

The device will include the following output means:

1. Two push button switches (one up one down) for selecting temperature set point in Cold Plate Cooling Mode.
2. Two push button switches (one up one down) for selecting flow rate set point in Cold Plate Cooling Mode.
3. Three visual indicator lights for:
 - Power to device (power on).
 - Temperature in control.
 - Blood/fluid outflow in control.
4. An LCD for displaying one of four patient temperatures in °C while in Blood/Fluid Cooling Mode and for displaying the set point temperature while in Cold Plate Cooling Mode temperature set point selection and for displaying the flow rate set point in liters/min while in Cold Plate Cooling Mode flow set point selection.

- LCD and indicators must be easily viewed and readable from a distance of 5 feet.
 - All indicators are on/off type.
5. A buzzer for audio alerts in case of malfunction.

2.3.5 Device Acceptance Criteria

1. Use the parameters defined above to establish the device performance acceptance criteria and test for compliance in the manufacturing process. In addition to performance aspects, test the device to verify full functionality.

2.4 Reliability Requirements

TBD

2.5 Safety Risk Management Requirements

TBD

3. Product Interface Requirements

3.1 Customer Interface Requirements

3.1.1 Operator Interface

The operator interface (device controls, readouts, etc.) should be kept to a minimum.

1. Selection of blood/fluid flow rate will be through the use of push button switches.
2. Selection of the blood/fluid temperature will be through the use of push button switches.
3. Simple readouts displaying one of four selectable patient temperatures probed at predetermined body locations.
4. On/off switches for power to the device and also to the blood/fluid pump.

3.1.2 Patient Interface

1. There will be direct, yet minimal, contact between the device and the patient.
2. The device will connect up to catheters for both inflow and out flow (veno-venous or arterio-venous). The catheters and cannula are not part of the device.
3. The device will have four (4) connection points allowing for patient temperature monitoring equipment.

3.2 External Interface Requirements

4. No external interface is required.

3.3 Labeling Requirements

1. Labeling will provide the following:
 - Product name and model number
 - Power input requirements
 - Generic product descriptions
 - Package contents
 - Serial number
 - Address and telephone number of manufacturer
2. Labeling will also contain the following wording prominently displayed:
"CAUTION: Federal (USA) law restricts this device to sale by or on the order of a physician"
3. Affix product identification labeling to each device and shipping container.
4. Place appropriate warnings and notices in the operator's instruction manual shipped with each device.
5. Apply labeling in such a manner that it cannot be removed or destroyed by normal cleaning or other factors per FDA CFR 801, UL 2601, IEC 601 and MDD.
6. Labeling will comply with requirements of MDD, 93/42/EEC and FDA Title 21 CFR 820.

3.4 Service Delivery Requirements

TBD

4. Product System and Program Requirements

4.1 Business Risk Management Requirements

TBD

4.2 Customer Service and Product Support Requirements

TBD

4.3 Financial Requirements

TBD

4.4 Manufacturability Requirements

TBD

4.5 Manufacturing Requirements

TBD

4.6 Marketing Requirements

TBD

4.7 Packaging Requirements

TBD

4.8 Regulatory Compliance Requirements

FDA PMA approval is planned.

4.9 Shipping Requirements

TBD

4.10 Standards Compliance Requirements

7. Comply with domestic standards including FDA guidance and CFR's.
8. For the European Union, comply with market based standards including MDD, 93/42/EEC.
9. AAMI HE 48-1993: Human Factors Engineering Guidelines and Preferred Practices for Design of Medical Devices.
10. IEC 601-1, 1996: Medical Electrical Equipment-General Requirements for Safety
11. ISO 10993-1: Biological evaluation of Medical Devices 1992
12. ASTM D4169-86: Standard Practice for Performance Testing of Shipping Containers and Systems
13. UL 2601-1 Standard for Medical Electrical Equipment, Part 1: General Requirements for Safety - Second Edition October 24, 1997
14. IEC 601-1-2 (References CISPER 11)
15. EN 1441-1994: Medical Device-Risk Analysis
16. EN 55011
17. FDA CFR 801

4.11 Statutory Compliance Requirements

TBD

4.12 Testability Requirements

TBD

5. References

6. Revisions and Updates

DRD_Profound Hth
Rev. 0

Profound Hypothermia Induction Device
Design Requirements
Program No. 78



Table of Contents

Product Functional Requirements	3
1.1 Maintainability Requirements	3
1.1.1 User Maintenance.....	3
1.2 Operational Requirements	3
1.2.1 Physical Description.....	3
1.2.2 Intended Use	3
1.2.3 Operating Modes	3
1.3 Quality Requirements	4
1.4 Repairability and Serviceability Requirements.....	4
2. Product Performance Requirements	5
2.1 Durability Requirements.....	5
2.2 Environmental Requirements	5
2.2.1 Operating.....	5
2.2.2 Shipping and Storage	5
2.3 Performance Requirements	5
2.3.1 Design Performance	5
2.3.2 Accessories Performance	6
2.3.3 Physical Performance	6
2.3.4 Output performance.....	6
2.3.5 Device Acceptance Criteria.....	7
2.4 Reliability Requirements	7
2.5 Safety Risk Management Requirements	7
3. Product Interface Requirements.....	8
3.1 Customer Interface Requirements.....	8
3.1.1 Operator Interface.....	8
3.1.2 Patient Interface.....	8
3.2 External Interface Requirements	8
3.3 Labeling Requirements	8
3.4 Service Delivery Requirements	8
4. Product System and Program Requirements	9
4.1 Business Risk Management Requirements	9
4.2 Customer Service and Product Support Requirements.....	9
4.3 Financial Requirements	9
4.4 Manufacturability Requirements	9
4.5 Manufacturing Requirements	9
4.6 Marketing Requirements	9
4.7 Packaging Requirements	9
4.8 Regulatory Compliance Requirements	9
4.9 Shipping Requirements.....	9
4.10 Standards Compliance Requirements.....	9
4.11 Statutory Compliance Requirements	10
4.12 Testability Requirements.....	10
5. References.....	11
6. Revisions and Updates	12

Product Functional Requirements

1.1 Maintainability Requirements

1.1.1 User Maintenance

1. The device will have external panels suitable for easy cleaning as appropriate for a surgical theater environment.
2. No routine or scheduled calibration or maintenance, other than normal cleaning, will be required for operation of the device.

1.2 Operational Requirements

1.2.1 Physical Description

The device is a stand-alone product with a delivery pump and custom electronics used to administer a chilled sterile solution to a patient at a predetermined flow rate.

1. The device will consist of:
 - A durable framed enclosure containing an insulated cold box, pump and custom electronics.
 - Inner cooling chamber capable of holding a filled 20-liter bag of sterile solution.
 - A pump for administering a chilled solution.
 - Simple controls for easy adjustment.
2. The device will be operated from a standing position with a simple display and input controls for easy monitoring and adjusting over a reasonable range of operator sizes and positions.
3. The device will be mobile with wheels and ease of movement such that a single individual can maneuver it around a hospital and in and out of an elevator. For ease of mobility, the device will:
 - Weigh a maximum of 63.5 kg, including the filled bag of sterile solution.
 - Contain lockable swivel casters.
 - Contain two fold away handles.

1.2.2 Intended Use

1. Operators will use this device to induce profound hypothermia (core body and brain temperature within 10 to 20°C) to patients during cardiac arrest (no volumetric flow).
2. The device will be of a size that accounts for 95% of the adult population as defined in the AAMI HE 48-1993: Human Factors Engineering Guidelines and Preferred Practices for Design of Medical Devices.

1.2.3 Operating Modes

1.2.3.1 General

1. The device will operate in the following modes:
 - Pre-cooling/Chilling Mode
 - Solution Administering Mode
2. The operator will determine the mode of operation.
3. The typical operation will consist of:
 - Chilling a filled bag of sterile solution to a preset temperature and maintain that temperature.
 - Administering the chilled sterile solution to the patient.

1.2.3.2 Pre-cooling/Chilling Mode

In this mode, the device will chill a filled bag of sterile solution to a preset temperature and maintain that temperature.

1. The operator will initially turn the unit on.
2. The operator will select the desired sterile solution temperature to be achieved from preset values of -10°C to 4°C at 1°C increments.
3. The operator will place a filled bag of sterile solution into the cold box chamber. The sterile solution can be at either at ambient temperature or at a pre-cooled temperature.
4. The operator will insert a single use only (disposable) YSI 400 thermistor hypodermic needle type temperature probe into the filled bag.
5. The device will monitor the temperature of the sterile solution and adjust accordingly.
6. Once the solution has reached its predetermined set point, the device will maintain that temperature to within +/- 0.5°C.
7. The device will indicate the solution has reached the preset temperature.
8. The temperature of cold box will be monitored when the sterile solution is not present.

1.2.3.3 Solution Administering Mode

In this mode, the device will pump the chilled sterile solution to the patient at preset temperature and flow rate.

1. The operator will connect the sterile disposable tubing set to the device.
2. The operator will prime the disposable tubing set and/or pump with the sterile solution.
3. The operator will select the desired flow rate in which to administer the chilled solution to the patient from preset values of 1 to 2 liters/min at 100 ml/min increments.
4. The operator will connect the device to the patient via a balloon catheter and temperature sensors.
5. The operator will switch the pump on and begin administering the chilled sterile solution to the patient.
6. As the solution is being pumped to the patient, the device will continue to maintain the solution at the preset temperature to within +/- 0.5°C.
7. The device will automatically shut off the pump once the bag of sterile solution is empty.
8. The device will display one of the two monitored patient's core temperatures selected by the operator over a temperature range of 5°C to 37°C.
9. The device will alert the operator if a detected fault arises or if it becomes unable to maintain solution temperature or flow.

1.3 Quality Requirements

1. Quality processes will assure that purchased components meet specifications through the use of inspection instructions.
2. Quality processes will assure that manufactured components meet specifications with first article inspections, inspection instructions and continued statistical sampling.
3. Before shipping, quality assurance will verify that all manufacturing and testing processes were successfully performed on the device.
4. The manufacturing process and quality system will comply with applicable requirements of ISO-9001 and FDA QSR and other applicable standards, directives or regulations.

1.4 Repairability and Serviceability Requirements

1. The manufacturer will perform all repairs and service

2. Product Performance Requirements

2.1 Durability Requirements

1. The device will withstand normal levels of shock and vibration without incurring functional damage. Normal shock and vibration include:
 - Transporting device around a hospital.
 - Loading and unload of the device into emergency vehicles.
 - Hitting walls and other fixed objects at a walking speed.
2. All exposed surfaces will be resistant to damage from commonly used hospital/clinical cleaning fluids (such as alcohol and 10% bleach), salts, body fluids and glucose solutions.

2.2 Environmental Requirements

2.2.1 Operating

1. Operating Temperature: 15°C to 30°C
2. Non-condensing Humidity: 30% to 75%
3. Altitude: as defined in IEC 601-1

2.2.2 Shipping and Storage

1. Storage Temperature: -35°C to 70°C
2. Storage Pressure: 68 kPa to 106 kPa
3. Storage Relative Humidity: 15% to 95% non-condensing

2.3 Performance Requirements

2.3.1 Design Performance

2.3.1.1 General Operation

1. The device will have a visual indicator light to signal the operator that the device has been turned on.
2. During pre-cooling/chilling mode, the device will notify the operator via an indicator light once the sterile solution has reached its predefined set point temperature and will stay on to indicate that the set point temperature is maintained.
3. During solution administering mode, the device will notify the operator that the pump is running properly and pumping at the selected flow rate via an indicator light.
4. An audio alert will sound if there is a malfunction or the temperature and flow rate set points cannot be maintained.

2.3.1.2 Accuracy

1. The device will be capable of cooling a sterile solution from ambient (room) temperature to a predetermined temperature and maintain that temperature with an accuracy of +/- 0.5°C. The readout accuracy will be +/- 0.2°C over the temperature range.
2. The device will be capable of administering the chilled sterile solution to the patient at a predetermined flow rate with an accuracy of +/- 10% for any selected flow rate.
3. The chilled sterile solution will be pumped through a 3 meter 0.25 ID disposable tubing set. The tubing and pump must be designed to withstand 138 kPa.
4. The device will monitor two (2) patient temperatures. The patient's temperature readout accuracy will be +/- 0.2°C over the specified range.

2.3.1.3 Electrical Power

1. The device electrical input requirements from an external source are listed below.
 - Line Voltage: 115 volts +/- 10%
 - Line Current: 2 amps maximum.
 - Line Frequency: 60 Hz +/- 3 Hz
2. The device will have a suitable hospital grade power cord.

2.3.2 Accessories Performance

1. Provide two (2) temperature sensor inputs from YSI 400 compatible thermistors to monitor the patient's temperature if required. They will be single use devices (disposable).
2. All tubing sets will be disposable for single use only and have the following features:
 - Tubing clamps located at the inflow and outflow.
 - Ease of priming.
 - A pumping segment compatible with the pump selected.
 - Constructed of clear 0.25" ID medical grade tubing.
 - Biocompatible per ISO 10993-1.
 - Means of easily securing the tubing set to the device.
 - Clear method of checking for proper installation.
 - Clear and concise method for removal while preventing spillage of any fluids.
 - Provide sterile solution to the patient.
 - Ease of connecting tubing set to the sterile solution bag and also the balloon catheter.

2.3.3 Physical Performance

1. The device will be mobile with a maximum force to initiate movement that complies with the requirements of AAMI HE 48-1993.
2. Incorporate a locking feature to prevent movement when desired.
3. Provide a stable center of gravity to prevent tipping and meet IEC 601-1, Section 24.
4. A standing operator will use the device.
5. Any fluid within the device will be protected from spillage during normal movement around the hospital.

2.3.4 Output performance

The device will include the following output means:

1. Two adjustable detent knobs for:
 - Sterile solution temperature
 - Pump flow rate
2. Three visual indicator lights for:
 - Power to device (power on)
 - Set point temperature of sterile solution reached and in control.
 - Flow set point in control.
3. An LCD for displaying one of the two monitored patient temperatures in °C.
 - LCD and indicators must be easily viewed and readable from a distance of 5 feet.
 - All indicators are on/off type.

4. A buzzer for audio alerts in case of malfunction.

2.3.5 Device Acceptance Criteria

1. Use the parameters defined above to establish the device performance acceptance criteria and test for compliance in the manufacturing process. In addition to performance aspects, test the device to verify full functionality.

2.4 Reliability Requirements

TBD

2.5 Safety Risk Management Requirements

TBD

3. Product Interface Requirements

3.1 Customer Interface Requirements

3.1.1 Operator Interface

1. The operator will interface the device via simple controls.
2. All temperature and flow rate adjustments will be made through the adjustable detent knobs.
3. A simple readout showing the patient's core temperature will be used.
4. All controls should be clearly marked and/or defined.

3.1.2 Patient Interface

1. There will be direct contact between the device and a patient.
 - The device will connect up to a balloon catheter that will supply the chilled sterile solution to the patient.
 - The device will have two (2) connection points allowing for patient temperature recording equipment.

3.2 External Interface Requirements

1. No external interface is required.

3.3 Labeling Requirements

1. Labeling will provide the following:
 - Product name and model number
 - Power input requirements
 - Generic product description
 - Package contents
 - Serial number
 - Address and telephone number of manufacturer
2. Labeling will also contain the following wording prominently displayed:
"CAUTION: Federal (USA) law restricts this device to sale by or on the order of a physician."
3. Affix product identification labeling to each device and shipping container.
4. Place appropriate warnings and notices in the operator's instruction manual shipped with each device.
5. Apply labeling in such a manner that it cannot be removed or destroyed by normal cleaning or other factors per FDA CFR 801, UL 2601, IEC 601 and MDD.
6. Labeling will comply with requirements of MDD, 93/42/EEC and FDA Title 21 CFR 820.

3.4 Service Delivery Requirements

TBD

4. Product System and Program Requirements

4.1 Business Risk Management Requirements

TBD

4.2 Customer Service and Product Support Requirements

TBD

4.3 Financial Requirements

TBD

4.4 Manufacturability Requirements

TBD

4.5 Manufacturing Requirements

TBD

4.6 Marketing Requirements

TBD

4.7 Packaging Requirements

TBD

4.8 Regulatory Compliance Requirements

FDA PMA approval is planned.

4.9 Shipping Requirements

TBD

4.10 Standards Compliance Requirements

1. Comply with domestic standards including FDA guidance and CFR's.
2. For the European Union, comply with market based standards including MDD, 93/42/EEC.
3. AAMI HE 48-1993: Human Factors Engineering Guidelines and Preferred Practices for Design of Medical Devices.
4. IEC 601-1, 1996: Medical Electrical Equipment-General Requirements for Safety
5. ISO 10993-1: Biological evaluation of Medical Devices 1992
6. ASTM D4169-86: Standard Practice for Performance Testing of Shipping Containers and Systems
7. UL 2601-1 Standard for Medical Electrical Equipment, Part 1: General Requirements for Safety - Second Edition October 24, 1997
8. IEC 601-1-2 (References CISPER 11)
9. EN 1441-1994: Medical Device-Risk Analysis
10. EN 55011
11. FDA CFR 801

4.11 Statutory Compliance Requirements

TBD

4.12 Testability Requirements

TBD

5. References

6. Revisions and Updates
