

REPORT DOCUMENTATION PAGE

Form Approved
OMB No. 0704-0188

Public reporting burden for this collection of information is estimated to average 1 hour per response, including the time for reviewing instructions, searching existing data sources, gathering and maintaining the data needed, and completing and reviewing this collection of information. Send comments regarding this burden estimate or any other aspect of this collection of information, including suggestions for reducing this burden to Department of Defense, Washington Headquarters Services, Directorate for Information Operations and Reports (0704-0188), 1215 Jefferson Davis Highway, Suite 1204, Arlington, VA 22202-4302. Respondents should be aware that notwithstanding any other provision of law, no person shall be subject to any penalty for failing to comply with a collection of information if it does not display a currently valid OMB control number. PLEASE DO NOT RETURN YOUR FORM TO THE ABOVE ADDRESS.

1. REPORT DATE (DD-MM-YYYY)		2. REPORT TYPE Technical Papers		3. DATES COVERED (From - To)	
4. TITLE AND SUBTITLE				5a. CONTRACT NUMBER	
				5b. GRANT NUMBER	
				5c. PROGRAM ELEMENT NUMBER	
6. AUTHOR(S)				5d. PROJECT NUMBER	
				5e. TASK NUMBER	
				5f. WORK UNIT NUMBER	
7. PERFORMING ORGANIZATION NAME(S) AND ADDRESS(ES) Air Force Research Laboratory (AFMC) AFRL/PRS 5 Pollux Drive Edwards AFB CA 93524-7048				8. PERFORMING ORGANIZATION REPORT	
9. SPONSORING / MONITORING AGENCY NAME(S) AND ADDRESS(ES) Air Force Research Laboratory (AFMC) AFRL/PRS 5 Pollux Drive Edwards AFB CA 93524-7048				10. SPONSOR/MONITOR'S ACRONYM(S)	
				11. SPONSOR/MONITOR'S NUMBER(S)	
12. DISTRIBUTION / AVAILABILITY STATEMENT Approved for public release; distribution unlimited.					
13. SUPPLEMENTARY NOTES					
14. ABSTRACT					
20021018 069					
15. SUBJECT TERMS					
16. SECURITY CLASSIFICATION OF:			17. LIMITATION OF ABSTRACT	18. NUMBER OF PAGES	19a. NAME OF RESPONSIBLE PERSON Leilani Richardson
a. REPORT Unclassified	b. ABSTRACT Unclassified	c. THIS PAGE Unclassified			

9 items enclosed

TP-1998-143

98-13A

MEMORANDUM FOR PRR (Contractor Publication)

43738002

FROM: PROI (TI) (STINFO)

13 July 1998

SUBJECT: Authorization for Release of Technical Information, Control Number: AFRL-PR-ED-TP-1998-143
Tim Lawrence et al. "Performance Testing of a Resistojet Thruster for Small Satellite Applications"

AIAA

(Statement A)

PERFORMANCE TESTING OF A RESISTOJET THRUSTER FOR SMALL SATELLITE APPLICATIONS

Lawrence, Timothy J.
United States Air Force
CSER, University of Surrey
Guildford, UK

Sweeting, Martin. Paul, Malcolm
Surrey Satellite Technology Ltd
Guildford, UK

Sellers, J.J.
European Office of Aerospace Research and Development
London, UK

LeDuc, J.R., Malak, J.B, Spanjers, G.G., Spores, R.A.
Air Force Research Laboratory
Edwards AFB, CA

Schilling, J.
Air Force Research Laboratory
Sparta, Inc.
Edwards AFB, CA

Abstract

Resistojets operating at low power (~100 W) and using liquid propellants have re-emerged as attractive propulsion options for orbit-raising small satellites deployed at Space Shuttle altitudes (~200 km). Compared to low power pulsed plasma thrusters (PPT), the resistojets produce two orders of magnitude more thrust (approximately 1.4 mN compared to 140 mN) which is required to overcome drag at solar maximum. The wet mass of both systems is approximately equal, although the propellant volume for the PPT is significantly lower since it is stored in solid form. The major disadvantage of the resistojets compared to the PPT, is in the complexity added from the propellant tanks. Shuttle integration concerns for the solid Teflon™ propellant of the PPT are minimal or non-existent. Although non-toxic, the water or nitrous oxide propellant of the resistojets requires pressurised tanks and valves which increase safety requirements.

To investigate the usefulness of the resistojets for small satellite applications, a series of performance tests have been completed at the AFRL Electric Propulsion Laboratory using the JPL inverted pendulum thrust stand. The tests

were conducted for two types of resistojets developed at the University of Surrey which utilise a packed bed of SiC particles for the heat exchanger. Performance testing was accomplished at power levels from 0 - 600 W for five propellants: water, nitrous oxide, water/methanol, nitrogen, and helium. Two endurance tests were conducted to determine possible failure modes. Performance characterisation and thermal models were developed for future design applications of these thrusters. Future USAF and Surrey Satellite Technology, Ltd. (SSTL) missions using these resistojets are also discussed.

Introduction

The success of small satellite missions depends on low-cost launch opportunities. So far, the majority of University of Surrey satellite (UoSAT) missions have been on *Ariane* launchers attached to the *Ariane* Structure for Secondary Payloads (ASAP) ring and deployed into LEO. Unfortunately, until now UoSAT spacecraft (as well as similar satellites built by other Universities and companies) lacked one critical system that would allow them to exploit fully emerging opportunities in LEO and beyond— a propulsion system. Propulsion

systems are a common feature on virtually all larger satellites. However, until now there has been no need for very small, low-cost satellites to have these potentially costly systems. As secondary payloads, smallsats were deployed into stable, useful orbits and natural orbit perturbations (drag, J2, etc.) were acceptable within the context of the relatively modest mission objectives.

Over the years, these pioneering small satellite missions have proven that effective communication, remote sensing and space science can be done from a cost-effective platform. As these missions have evolved, various technical challenges in on-board data handling, low-power communication, autonomous operations and low-cost engineering have been met and solved. Now, as mission planners look beyond passive missions in LEO to bold, new missions which require active orbit and attitude control, a new challenge is faced—cost-effective propulsion.

Besides cost, small satellites have other unique constraints compared to larger spacecraft:

1. Mass < 500 kg
2. Volume < 800 mm x 800 mm
3. Power 50 W - 150 W on orbit average
4. Integration safety, technical risk, non-toxic propellants

These constraints and mission trades associated with them led the University of Surrey to start a research programme in water and nitrous oxide (N₂O) resistojets for stationkeeping missions. Table 1 compares the performance trades between a nitrous oxide resistojet and a current industry approach using PPTs for small satellite stationkeeping. The data in Table 1 show that although the PPT has an order of magnitude increase in specific impulse, the resistojet has an order of magnitude increase in thrust for the same input power. In a high drag orbit, low thrust levels require very long trip times to move a 100 - 300 kg satellite, if even possible at all. The storage density of liquid nitrous oxide (710 kg/m³ @ 48 bar - self pressurizing) and efficiency allows this system to be quite attractive for stationkeeping missions (ΔV 25 - 200 m/s). Water is attractive due to its storage density (1000 kg/m³), specific impulse (150-200 sec Isp) and ease of handling.

System	PPT	N ₂ O R-jet
Power	100 W	100 W
Isp	1500 sec	150 sec
Density Isp	3465 sec	107 sec
Thrust	1 mN	100 mN
ΔV (experimental mission)	5.4	5.4
Mass of propellant	0.1 kg	1.1 kg
System mass	6 kg	8kg
Firing time for ΔV	19 days	3 hours
Change in semi-major axis (assuming initial orbit is 720 km)	7 km	7km

Table 1: Comparison of Metrics for a PPT and Resistojet

Because of these options, the University of Surrey started a low-cost research programme to flight qualify a water and nitrous oxide resistojet system. This paper summarises results obtained for three phases of the research programme - proof of concept, prototype, and protoflight. Test results obtained at the Edwards Air Force Base (AFB) Electric Propulsion Laboratory using the Jet Propulsion Laboratory (JPL) Inverted Pendulum test stand are presented. The paper concludes with a discussion of the flight applications of these thrusters. A more detailed description of the history of the programme can be found in Lawrence¹ and Lawrence et. al.²

Proof of Concept

The proof of concept effort was initiated in December of 1995. The Mark-I thrust chamber is 30 mm by 120 mm with a 10 mm by 110 mm commercial cartridge heater installed in the centre provided by Hedin in Essex, UK. The chamber is made of 304 stainless steel. The heater is composed of nickel-chromium alloy filament, magnesium oxide insulation, and an Inconel sheath. At 28 V input voltage, it is designed to produce 1000 W at a power density of 24 W/cm². Around the heater, the chamber is packed with the 500 μ m SiC. N₂O flow rate can be varied from 0.0002 to 0.0011 kg/s (variable area flow meter) at an inlet pressure of 10 bar. An injector was designed with six 500 μ m diameter holes to provide a uniform water flow to the bed. As it enters the chamber, the N₂O passes through a 2 mm sintered disk (65% porosity) which keeps the heat transfer material from interacting with the injector and also provides a pressure drop to decouple the inlet pressure from the chamber pressure. The N₂O

then flows across the bed, is heated, and passed out through the 0.5 mm throat diameter nozzle (expansion ratio is 25:1).

A 50 mesh stainless steel screen has been used at the aft end to contain the heat transfer material. The instrumentation in the thrust chamber consists of three pressure gauges and two thermocouples. Figure 1 shows the Mark-I resistojet along with this instrumentation.

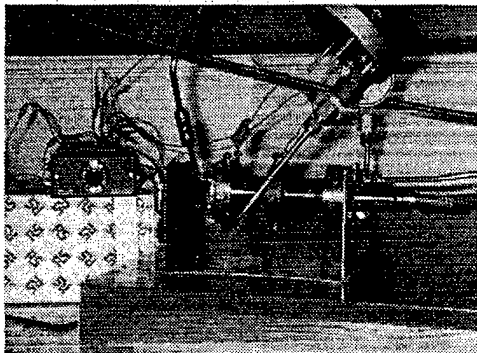

Figure 1: Mk-I Water Resistojet

The Mark-I demonstrated that a resistojet was feasible for small satellite application. All of the tests, which are summarized in Figures 2 and 3, show the fluid flow efficiency over time for one of the water and nitrous oxide runs. The efficiency is determined by taking the input power of the heater divided by the measured mass flow rate and showing the resultant chamber temperatures (T_c) for these input conditions. Figure 3 shows that the nitrous oxide required less power (at the same flow conditions) then water to achieve the same chamber temperature.

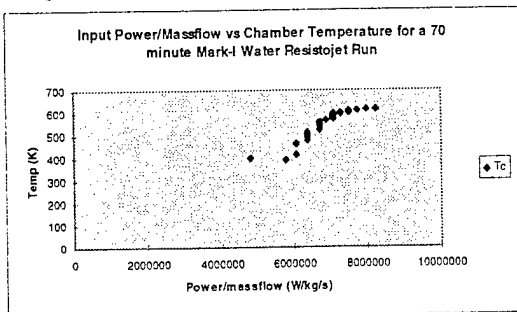

Figure 2: Chamber Temperature vs. Input Power /Mass Flow for Mk-I Resistojet (H_2O)

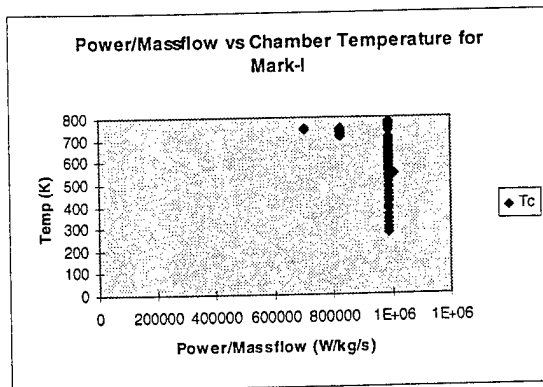

Figure 3: Chamber Temperature vs. Input Power /Mass Flow for Mk-I Resistojet (N_2O)

The efficiency results show that the nitrous oxide is slightly more efficient (factor of 10 in input power to mass flow rate for same chamber temperatures). This is because the nitrous oxide system does not have to expel energy to vaporise the propellant at the inlet.

Looking at the results over time for both of the runs, you can see the increase in efficiency as the system reaches steady state. For the water run, the mass flow rate decreases and chamber temperature rises over time while power and chamber pressure remain steady. For the nitrous oxide run, the mass flow and power remain steady (change in Figure 3 was from a manual increase in mass flow) while the chamber temperature and chamber pressure gradually rise. This behaviour over time is due to the heat conduction from the heater to the bed, the convection from the bed to the working fluid, and then radiation losses to the outside.

These results can be also be expressed in terms of heat transfer efficiency. Figure 4 represents an energy balance calculation for the Mark-I thruster using nitrous oxide as the working fluid. It is a division of the output energy in the exhaust (kinetic energy of the exhaust - jet power) over the input energy. This can be expressed as:

$$Q_{eff} = \frac{\dot{m}V_{exit}}{2P_{in}}$$

where all of the variables are measured, except for V_{exit} . This variable, however, can be calculated using the ratio of specific heats, measured chamber temperature, and measured chamber pressure. The step changes on the figure are due to changes in the power and mass flow settings.

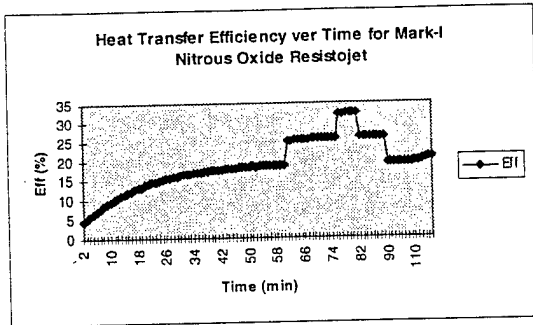

Figure 4: Heat Transfer vs. time Mark- I Resistojet

The Mark-I was not tested on a thrust stand. The thermodynamic data generated from the thruster instrumentation and efficiency calculations were used for the next design phase.

Prototype Thruster

The Mark-II (Figure 5) was designed to improve on the problems encountered with the Mark-I. It had the following design improvements:

1. Improved heater: longer life and higher temperature (980 C) @ 200 W
2. Improved heat transfer efficiency: chamber dimensions decreased to 30 mm by 90 mm and added 25 mm of Micropore Insulation (SiO2) to reduce conduction losses.
3. Reduced instrumentation: 2 thermocouples (heater temperature and chamber temperature), and 2 pressure transducers (inlet and chamber) since previous instrumentation caused leaks and additional heat transfer losses
4. Welded fittings
5. Nozzle throat diameter: 0.12 mm

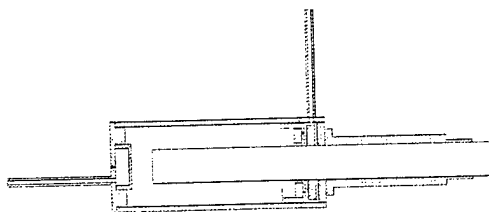

Figure 5: Mark-II Drawing

The Mark-II was tested at Royal Ordnance (RO) Wescott and at Edwards AFB using an inverted pendulum thrust stand developed by JPL. (Figure 6)

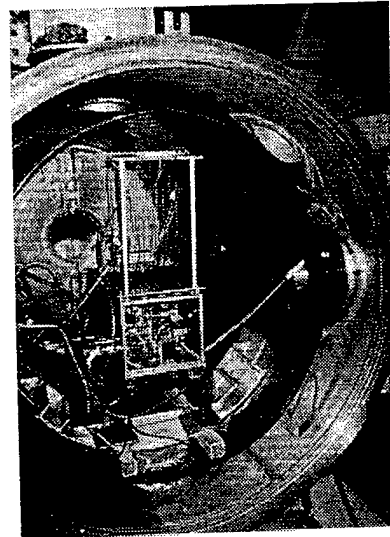

Figure 6: JPL Inverted Pendulum Thrust Stand

Using Figures 7 and 8 and the method described in the previous section, the efficiency as a function of time for a 100 W experiment can be determined. The heat transfer efficiency can be calculated in a different way since we have measured thrust. The measured Isp and thrust from the thrust stand can be used to calculate the exit jet power. The new relation becomes:

$$Efficiency = \frac{F I_{sp}}{P_{input}}$$

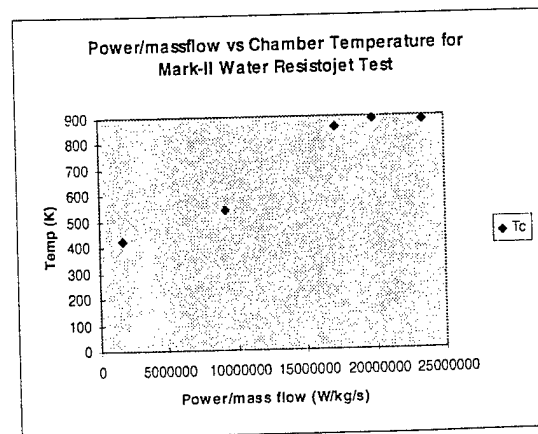

Figure 7: Chamber Temperature vs. Input Power /Mass Flow for Mk-II Resistojet (H₂O)

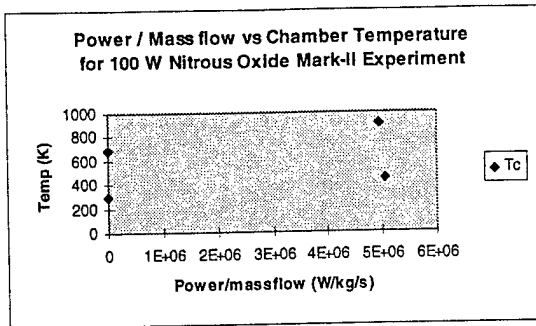

Figure 8: Chamber Temperature vs. Input Power /Mass Flow for Mk-II Resistojet (N₂O)

The heat transfer efficiency for the Mark-II is shown in Figure 9. The Mark-II results were slightly better than the Mark-I:

1. Heater lifetime: up to 150 hours without a failure (compared to several hours with the Mark-I heater)
2. Heat transfer efficiency: factor of 2 higher than Mark-I as far as chamber temperature and power/chamber temperature ratio

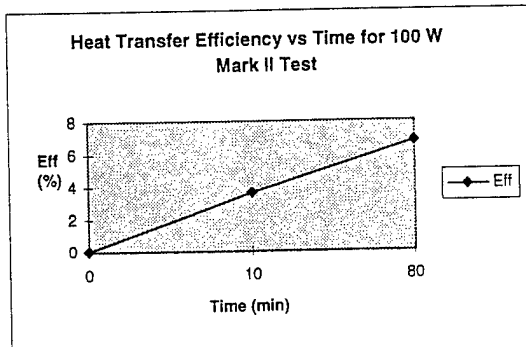

Figure 9: Heat Transfer Efficiency vs. Time for Mark- II Resistojet

Efficiency factors that were not discovered until the thrust stand data was analyzed were friction losses attributed to low flow rates. Since our flow rates were on the order of 10^{-6} kg/s, friction losses became dominant. This was due to the viscosity of the gas and the small nozzle throat size (0.12 mm throat). Total input power into the gas was not significant since the resulting increase in T_c was absorbed by friction losses in the throat. This was verified by conducting a Knudsen number and Reynolds number analysis looking at the nozzle flow conditions.³ The heat transfer efficiency only reached 12% with an I_{sp} of 84 as shown in figures 10 and 11. Even though we were using low input power (100 W), the thrust produced at the given mass flow rate

produced a low efficiency and hence I_{sp} . Figures 10 and 11 also show that even though less energy is required in the vaporisation of nitrous oxide, the I_{sp} is still lower than water. This is due to the high molecular weight of the nitrous oxide compared to water. Since the error in the thrust stand data was ± 3 mN, there could be as much as 40% uncertainty in the Mark-II thrust calculation since it is only 8 mN. Table 2 shows the summary of the Mark-II results (helium and nitrogen were tested for easier validation of the thermal model in initial tests). Thus in the next iteration, the Mark-III, it was decided to scale up the design for better resolution and study the nozzle losses in more detail.

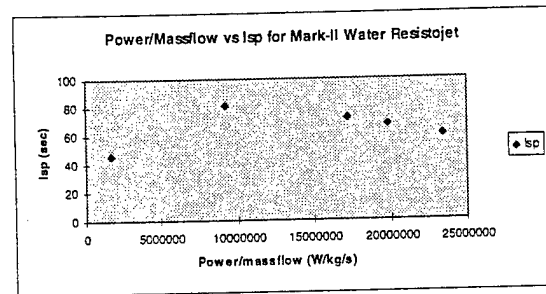

Figure 10: Isp vs. Input Power/Mass Flow for Mark-II Resistojet (H₂O)

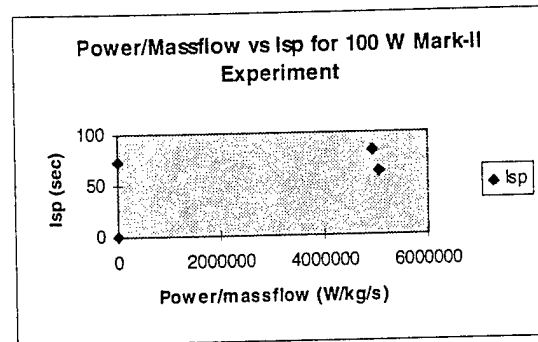

Figure 11: Isp vs. Input Power/Mass Flow for Mark-II Resistojet (N₂O)

Gas	I_{sp} (sec)	Q_{eff} (%)
N ₂ O	101	9.6
N ₂ O Cat	99	9.5
N ₂	103	9.8
H ₂ O	110	11.0

Table 2: Mark-II Results

Protoflight Thruster

The Mark-III, a larger system than the Mark-II, is shown in figure 12 below and has the following specifications:

1. 60 mm x 220 mm chamber
2. 300 - 600 W heater
3. Flow rate: 0.004 kg/s @ 10 bar
4. Nozzle throat: 0.7 mm diameter
5. 25 mm thick Micropore insulation
6. Welded fittings
7. Reduced instrumentation (since thrust stand data were used)

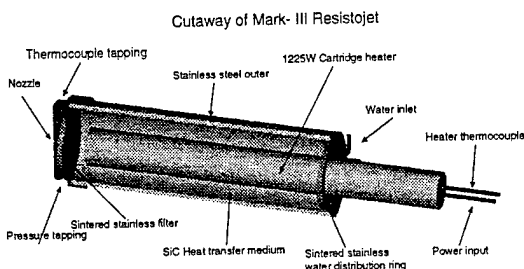

Figure 12: Cutaway of Mk-III Resistojet

The protoflight system achieved better performance than the previous designs. The system was designed for a thrust level of approximately 0.5 N (0.694 mm throat diameter). As with the Mark I and Mark II results, Figures 13 and 14 can be used to determine efficiencies for the N_2O experiments.

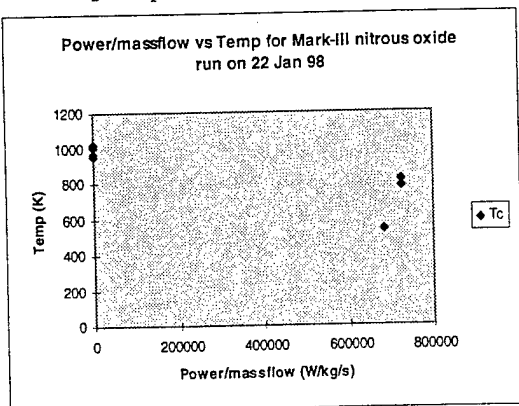

Figure 13: Chamber Temperature vs. Input Power /Mass Flow for Mk-III Resistojet (N_2O)

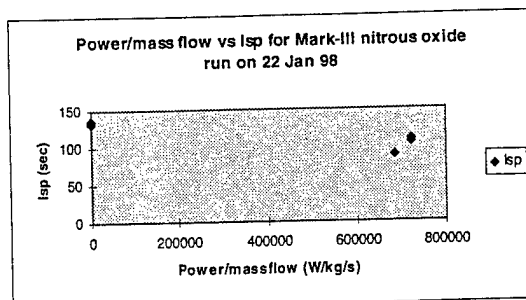

Figure 14: Isp vs. Input Power/Mass Flow for Mark-III Resistojet (N_2O)

The heat transfer efficiency calculations vs. time for N_2O are shown in Figure 15. In this test, 300 W of power was initially applied to the thruster. From hour 3 onwards, we were able to remove power from the thruster - the nitrous oxide exothermic decomposition reaction was able to sustain itself, resulting in the 100% efficiency in Figure 15. Figure 16 shows the heat transfer efficiency for the water system. The efficiency varied in the thruster from 25 - 40 % - due to varying the flow parameters.

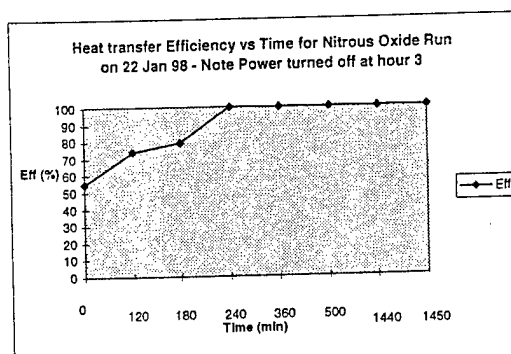

Figure 15: Heat transfer efficiency vs.time for the Mark-III (N_2O)

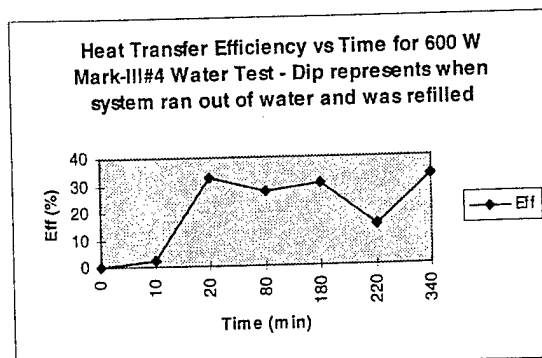

Figure 16: Heat transfer efficiency vs.time for the Mark-III (H_2O @ 600 W)

Figures 13-16 show the differences in the different working fluids. Even though the nitrous oxide system achieves a higher chamber temperature at a lower input power (factor of 3), the Isp is lower (factor of 1.3) than the water system.

Figures 17-20 and Table 3 summarize the experimental results. These results more closely matched the theoretical Isp calculations which show the friction losses encountered with the Mark-II is not a factor in this system. The Mark-III produced much better results compared to the Mark-II. Since the total error bar is less than 4% there is higher confidence in these numbers.

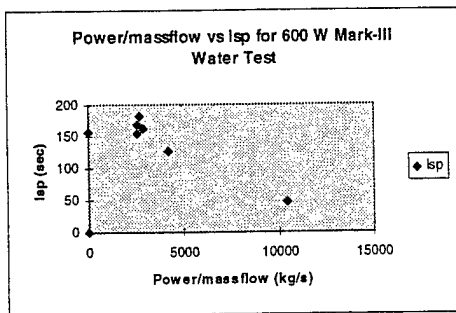

Figure 17: Isp vs. Input Power/Mass Flow for Mark-III Resistojet (H₂O)

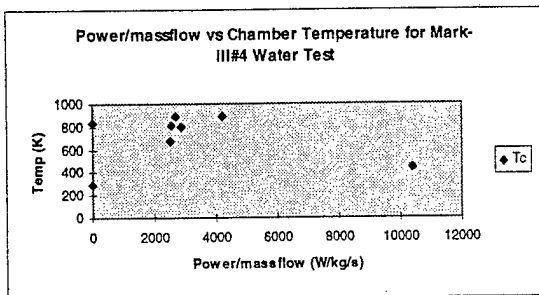

Figure 18: Chamber Temperature vs. Input Power /Mass Flow for Mk-III Resistojet (H₂O)

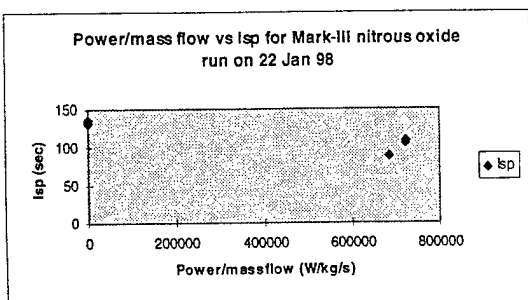

Figure 19: Isp vs. Input Power/Mass Flow for Mark-III Resistojet (H₂O)

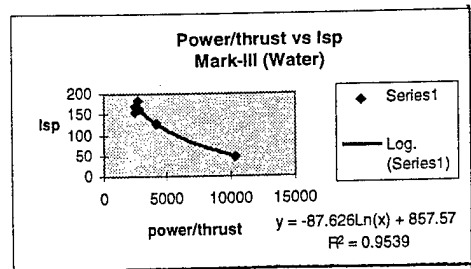

Figure 20: Power/thrust for Mark-III Water Resistojet Experiment

Gas	Isp (sec)	Qeff (%)
He	334	61.3
N ₂ O	148	81.8
N ₂	134	57.7
H ₂ O	182	25.4
H ₂ O/Methanol	169	24.7

Table 3: Performance for Mark-III Research Programme

Mark-IV

The test results obtained in the Mark-III programme showed that a flight qualified system with good performance is feasible. We decided to do a long endurance experiment using one of the Mark-III thrusters (there were 4 thrusters fabricated). This thruster used a smaller nozzle design of 0.183 mm. The results are shown in Figures 21 and 22 where a decrease in thrust is seen over time. The large drops in thrust are due to power outages at the laboratory. Post inspection of the nozzle and bed discovered silicon oxide deposits. SEM analysis showed that the silicon oxide was in the bed material before operation. Thermal vacuum treatment and a new silicon carbide bed material will alleviate this problem in future applications.

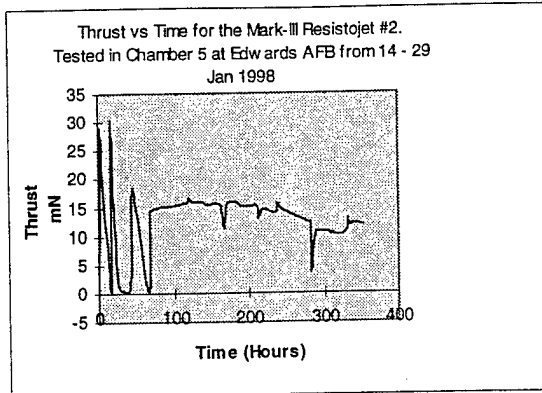

Figure 21: Thrust vs. Time for 190 W water resistojet experiment - Details in Appendix A

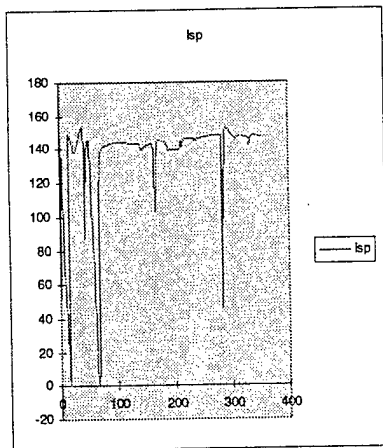

Figure 22: Isp vs. Time for 190 W water resistojet experiment - Details in Appendix A

A detailed analysis of the cumulative experimental results was used to design the Mark-IV, whose specifications are shown in Table 4. This consisted of analyzing the Knudsen and Reynolds numbers, thrust coefficients, empirical analysis of the experimental results, and a thermal model developed using the Achenbach heat transfer relation and Ergun pressure drop correlation with the empirical results of the fluid heat transfer characteristics.

MightySat II.1 Mission

The first use of a Mark-IV resistojet in an orbit raising application for small satellites will be demonstrated in a cooperative effort between the US Air Force Research Laboratory (AFRL) Propulsion Directorate and Space Systems

Technology Limited (SSTL) of Surrey, England on the MightySat II.1 satellite.⁴ (Figure 23)

Item	Specifications
working fluid	water
Pressure	5 bar (10 bar inlet)
Mass flow	0.000066 kg/s
power	100 W
resistojet mass	1.5 kg
expulsion system mass	6 kg
water mass	2.3 kg
Isp	180 sec
Thrust	50 mN
ΔV	45 m/s
Nozzle	0.3 mm
assembly	electron beam welded

Table 4: Mark-IV System Specifications

The MightySat program is managed by the Space Vehicles Directorate of AFRL at Kirtland AFB, NM for the purpose of demonstrating AFRL developed technologies in a timely and cost-effective manner. The prime contractor, Spectrum Astro, of Gilbert, AZ, successfully completed a Detailed Design Review in February and is currently building the first in a series of MightySat II spacecraft. The first of this series, MightySat II.1, known as Sindri, is scheduled for launch in January, 2000.

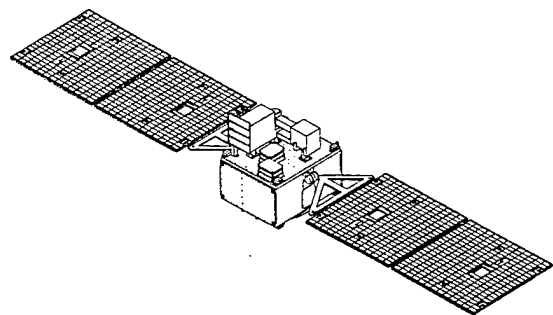

FIGURE 23: MightySat II.1 Spacecraft

The Mk-IV was originally designed to perform a critical orbit raising maneuver to extend the MightySat II.1 mission life from an estimated 50 days to 1 year when released from the Space Shuttle payload bay at an altitude of 220 nautical miles (nm). This orbit raising function, however, is no longer required since the primary launch vehicle for Sindri was change from the shuttle to Orbital Sciences Corporation's Minotaur. At an insertion altitude of 300 nm, the higher orbit altitude provided by the Minotaur ensures a one-year mission life is achieved without on-board propulsion. The Mark-IV resistojet's original design requirements are maintained, however, because Sindri or future spacecraft in the MightySat series are baselined for launch from the Shuttle. A Space Shuttle launch is an attractive option for MightySat due to the significant reduction in costs compared to those of the Minotaur vehicle. Sindri's January, 2000 launch date places the orbit raising maneuver right at the beginning of the solar maximum cycle, which will dramatically increase spacecraft orbit decay rates. This in turn will increase the demands on the Mk-IV design.

Prior to manifesting the Mk-IV resistojet on MightySat II.1, a mission analysis was completed to determine the design requirements necessary for the thruster to meet the spacecraft's 1 year on-orbit life requirement. Table 5 shows the results of this analysis for typical Space Shuttle and Minotaur insertions. The critical factor determined by the analysis is the amount of propellant required to maintain the mission life requirement. For a Space Shuttle insertion altitude, the propellant mass is especially critical since the MightySat II.1 spacecraft is volume constrained due to the finalization of its design. There are alternatives available to meet mission requirements, but these options also have extensive re-design and cost implications.

For the MightySat II.1 flight, three Mk-IV thrusters will be constructed as shown in Figure 24. Two will be shipped from Surrey to Edwards AFB, CA and are designated US-1 and US-2. US-1 will undergo a series of performance baseline tests on a thrust stand and then a 300 hour continuous operation test to demonstrate that the Mk-IV can meet the lifetime requirements for the orbit raising mission. After US-2 is received at Edwards, it will go through a brief acceptance performance test and then be shipped to the Aerospace Engineering Facility

(AEF) at Kirtland AFB for proto-qual testing. Once the environmental tests on US-2 are complete, the resistojet will be integrated with the MightySat II.1 spacecraft. The third thruster, designated UK-1, will undergo similar performance testing in England concurrent with the US-1 and -2 tests. Additionally, however, UK-1 will be cut open after vibration and life tests to examine the condition of the SiC particle bed.

	Space Shuttle	Minotaur
No Propulsion		
Solar Flux	F10.7 = 225	F10.7 = 225
Mission Life	50 days	380 days
Mk-IV Resistojet		
Isp	178 sec	178 sec
Thrust	50 mN	50 mN
Power	100 W	100 W
Initial Altitude	220 nm	300 nm
Solar Flux	F10.7 = 225	F10.7 = 225
Burn Time	3.2 days	Not Required
Mission Life	365 days	380 days
Propellant Required	5.3 kg	0 kg

Table 5: Propulsion Requirements for MightySat II.1 Mission

In addition to the US-2 thruster, a sister payload termed the Plume Diagnostic Experiment (PDE) will determine the effects of plume contamination from the thruster on typical optical surfaces. The PDE consists of two panels on different spacecraft surfaces. Each panel is thermally isolated from the spacecraft and has a quartz crystal microbalance and calorimeter mounted in an insulated enclosure. More information on the PDE is available in LeDuc et. al.⁴

Conclusions

The most cost-effective propulsions system can only be found by weighing all options within the context of a given mission. For very low-cost, logistically constrained missions, unconventional options such as water and nitrous oxide resistojets offer many unique advantages over current off-the shelf options. Future research

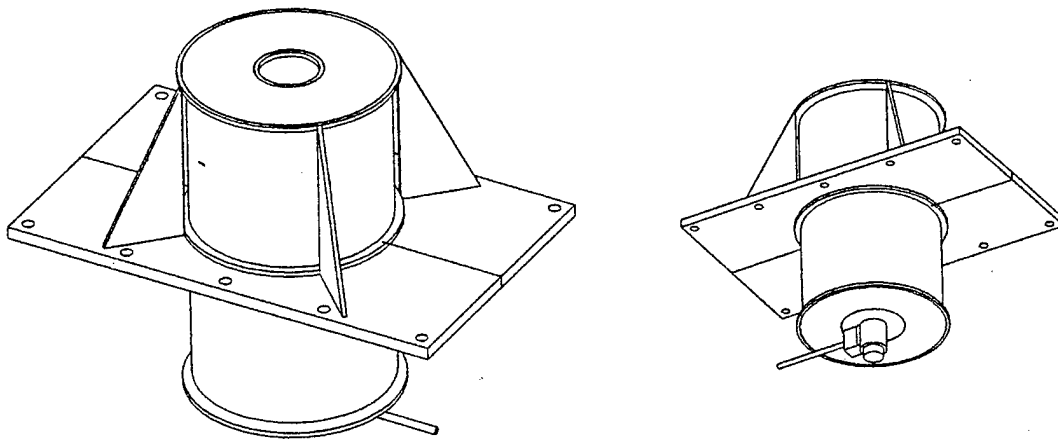

Figure 24: Mark-IV Resistojet – Top and Bottom Views

will focus on demonstrating these technologies in orbit.

Acknowledgements

The authors would like to acknowledge the following individuals: Daron Bromaghim, and Capt Rich Salasovich of the AFRL Electric Propulsion Laboratory; Randy Kahn, Capt Mike Rice, and Capt Rich Neufang of the MightySat Program Office; Pete Thomas and Robert Davis of the Aerospace Corporation; all of the MightySat team at Spectrum Astro; John Fumo and Bruce Moore of Trisys, Inc.; Royal Ordnance Wescott UK; Dr. Ron Humble of the United States Air Force Academy; and John Blandino of the Jet Propulsion Laboratory.

References

1. Lawrence T.J., "Research into Water Resistojets for Small Satellite Application", MPhil./Ph.D. Transfer Report, Department of Electrical Engineering, CSER, University of Surrey, Guildford UK, Sep 1996.
2. Lawrence, T., Sweeting, M., Paul, J., Drum, J., Humble, R., and Sellers, J. "Results of Cold Gas and Resistojet Research for Small Satellite Application", 11th Annual AIAA/USU Small Satellite Conference, Logan, Utah, September 1997.
3. Lawrence, T. "Research into Resistojet Rockets for Small Satellite Applications",

Ph.D. Thesis, Department of Electrical Engineering, CSER, University of Surrey, Guildford, UK June, 1998.

4. LeDuc, J.R., et. al. (1997), "Mission Planning, Hardware Development, and Ground Testing for the Pulsed Plasma Thruster (PPT) Flight Demonstration on MightySat II.1", 33rd Joint Propulsion Conference, Seattle, WA. AIAA 97-2779

Test #	Date	Gas	4.8-calc	94-calc	7.4-calc	10	447	2.9	5.24E-06	29
Mark-II#1 Thrust on torsion stand - problem with flexures	18/12/97 5 hr 10 min	nitrogen	4.8-calc	94-calc	7.4-calc	10	447	2.9	5.24E-06	29
Mark-II#1 thrust too high for torsion stand	17/12/97 5 hr	nitrogen	4.78-calc	134-calc	2.25-calc	100	618	10.2	3.63E-06	31
Mark-III#1 repeat run of 15/12/97	16/12/97 7 hr 40 min	nitrogen	30	103	7.8	193.6	635.9	10.2	2.96E-05	50
Mark-III#3 ran off decay heat from N2O run	15/11/98 1 hr 20 min	nitrogen	32	79	N/A (no power)	0	329	10.7	4.2E-05	38
Mark-III#1 repeat test of 12 Dec	15/12/97 7 hr	nitrogen	27	89	5.5	213	563.5	10.1	3.1E-05	59
Mark-III#1 first test at RO Wescott no stand	26/11/97 2 hr	nitrogen	50 (calc)	99 (calc)	13	292	607	10.8	5E-05	.3 millibar only at RO
Mark-II#1 first thrust recording - drift 100% of thrust value	9/12/97 1 hr 20 min	nitrogen	9.3	65	2.1	143	689.1	9.8	1.47E-05	66
Mark-II#1 still have drift in thrust reading	10/12/97 7 hr 35 min	nitrogen	12.2	85	5.1	100	642.6	8.9	1.47E-05	66.5
Mark-III#1 first no drift thrust reading - shut off flow to zero out stand. only 2 points	11/12/97 2 hr	nitrogen	28	89	6.1	200	554.4	10.4	3.21E-05	66.4
Mark-III#1 first no drift reading over operating range	12/12/97 3 hr 5 min	nitrogen	27	94	5.6	221	682.4	10.2	2.96E-05	68
Mark-III#4	17/1/98	nitrogen	445	134	75	389	657.1	7.5	.00034	104

first test with big nozzle	3 hr 10 min									
Mark-III#1 n2 endurance test	26-28/1/98 43 hr 35 min	nitrogen	24.7	93	6.25	180	600.7	8.4	2.71E-05	32.5
Mark-II#1 higher pressure	7/1/98 2 hr 40 min	nitrogen	14	94	6.36	101	621	11.3	1.52E-05	45.7
Mark-III #4 ran after n2 test	17/1/98 30 min	helium	314	249	76.12	504	559.5	5.9	.000128	123
Mark-III#4 ran after N2O test	22/1/98 1 hr 40 min	helium	357	303	133 - too much decay heat from N2O run	398	409	5.7	.00012	84.2
Mark-II #1 first he run	7/1/98 3 hr 20 min	helium	6.1	101	3	101	618.1	7.7	5.31E-06	44.3
Mark-II#1 100W perf.	19/12/97 4 hr 37 min	water	4.1	74	1.5	100	623.1	4.3	5.64E-06	48.7
Mark-III#2 long endurance test for MightySA TII.1	14/1/98-29/1/98 354 hr	water	14.5	146	5.4	192	584	5.91	1.01E-06	54
Mark-III#1 repeat test of 17/12/98	18/12/97 6 hr 30 min	water	9.7	88	2.1	203	632.8	4.8	1.12E-05	52.9
Mark-II#1 first water test with good thrust measurement	17/12/97 4 hr	water	10.5	85	2.2	203	658.4	4.6	1.26E-05	67.4
Mark-III#1 first test on water @RO Wescott	26/11/97 1 hr 45 min	water	13.4	171	3	382	588	5.1	.000008	.3 mili bar
Mark-II#1 first attempted thrust measurement - not accurate	9/12/97 40 min	water	2.1 mN	37	0.3	143	593.2	4.4	5.92E-06	159 (found leak afterwards)
Mark-III#4 First water test with big thruster - clogged nozzle with	19/1/98 4 hr 27 min	water	250	155	31.23	609	340.8	3.8	.000165	76.4

ice up to 100 bar. cleared and thruster kept running										
Mark-III#4 second water test	20/1/98 7 hr 10 min	water	233	182	33	631.4	618.7	3.8	.00013	71.3
Mark-III#4 repeat water test	23/1/98 2 hr 37 min	water	243	177	33	640.14	490.9	3.8	.00014	73.6
Mark-III#1 repeat water test of #1 done with smaller weight set and no viscojet	24/1/98 5 hr 50 min	water	24	110	4.85	266.96	652.4	8.7	2.25E-05	45.2
Mark-III#2 thrust measurement after 354 test	29/1/98 1 hr 40 min after 354 hr	water	1.55	20	.07	220	272.7	10.3	7.78E-06	34.5
Mark-II#1 100W test for performance again	8/1/98 5 hr 15 min	water	4	72	1.5	102	587.9	6	5.92E-06	48.9
Mark-III#4 60% water 40% Methanol by weight, used to lower freezing point of water to -20 C	23/1/98 2 hr 50 min	water/methanol	196	169	25.6	635.6	609.6	3.3	.000119	63.7
Mark-III#1 poor performance due to nozzle clog in middle of run	26/1/98 3 hr 15 min	water/methanol	2.1	31	.15	219.3	637.4	7.3	7.13E-06	30.9
Mark-III#3 test with MgO catalyst and insulation on	15/1/98 6 hr 12 min	N2O	28.8	96	4.5	302	734	10.8	3.07E-05	39.6
Mark-III#1 no catalyst	12/1/98 7 hr 34 min	N2O	26.2	101	8.7	149	641.7	11.2	2.63E-05	43.2
Mark-III#3 catalyst test and no	14/1/98 6 hr 20 min	N2O	33.4	75	4.1	297	377.7	11	4.52E-05	39.9

insulation for its impact on performance										
Mark-III#3 catalyst test with insulation on	13/1/98 6 hr 26 min	N2O	29.9	99	4.8	301	743.5	10.8	3.07E-05	44.1
Mark-II#1 comparative test to 9 Jan 98 which had the MgO catalyst	10/1/98 2 hr 5 min	N2O	17	83	6.7	103	626.1	12.9	2.09E-05	46.6
Mark-II#2 test with catalyst	9/1/98 5 hr 45 min	N2O	9.2	74	2.8	121	654.54	10.7	1.28E-05	44.1
Mark-III#4 first test with big nozzle, no catalyst	21/1/98 5 hr	N2O	524	148	110% - decomposition occurring	345	916.8	8.8	.00036	56.3
Mark-III#4 Repeat test of yesterday, shut power off at hour 3, ran for 20 hours with no power	22/1/98 23 hours	N2O	524	137	N/A - no power on	0	678.2	7.3	.00039	60.2