

AD\_\_\_\_\_

Award Number: DAMD17-00-1-0296

TITLE: DNA Base Excision Repair (BER) and Cancer Gene Therapy:  
Use of the Human N-Methylpurine DNA Glycosylase (MPG) to  
Sensitive Breast Cancer Cells to Low Dose Chemotherapy

PRINCIPAL INVESTIGATOR: Mikael L. Rinne  
Mark R. Kelley, Ph.D.

CONTRACTING ORGANIZATION: Indiana University  
Indianapolis, Indiana 46202-5167

REPORT DATE: June 2002

TYPE OF REPORT: Annual Summary

PREPARED FOR: U.S. Army Medical Research and Materiel Command  
Fort Detrick, Maryland 21702-5012

DISTRIBUTION STATEMENT: Approved for Public Release;  
Distribution Unlimited

The views, opinions and/or findings contained in this report are those of the author(s) and should not be construed as an official Department of the Army position, policy or decision unless so designated by other documentation.

20021101 050

# REPORT DOCUMENTATION PAGE

Form Approved  
OMB No. 074-0188

Public reporting burden for this collection of information is estimated to average 1 hour per response, including the time for reviewing instructions, searching existing data sources, gathering and maintaining the data needed, and completing and reviewing this collection of information. Send comments regarding this burden estimate or any other aspect of this collection of information, including suggestions for reducing this burden to Washington Headquarters Services, Directorate for Information Operations and Reports, 1215 Jefferson Davis Highway, Suite 1204, Arlington, VA 22202-4302, and to the Office of Management and Budget, Paperwork Reduction Project (0704-0188), Washington, DC 20503

<b>1. AGENCY USE ONLY (Leave blank)</b>		<b>2. REPORT DATE</b> June 2002	<b>3. REPORT TYPE AND DATES COVERED</b> Annual Summary (15 May 2001 - 14 May 2002)	
<b>4. TITLE AND SUBTITLE</b> DNA Base Excision Repair (BER) and Cancer Gene Therapy: Use of the Human N-Methylpurine DNA Glycosylase (MPG) to Sensitive Breast Cancer Cells to Low Dose Chemotherapy			<b>5. FUNDING NUMNUMBER</b> DAMD17-00-1-0296	
<b>6. AUTHOR(S)</b> Mikael L. Rinne Mark R. Kelley, Ph.D.				
<b>7. PERFORMING ORGANIZATION NAME(S) AND ADDRESS(ES)</b> Indiana University Indianapolis, Indiana 46202-5167 email - <a href="mailto:mrinne@iupui.edu">mrinne@iupui.edu</a> ; <a href="mailto:mkelley@iupui.edu">mkelley@iupui.edu</a>			<b>8. PERFORMING ORGANIZATION REPORT NUMBER</b>	
<b>9. SPONSORING / MONITORING AGENCY NAME(S) AND ADDRESS(ES)</b> U.S. Army Medical Research and Materiel Command Fort Detrick, Maryland 21702-5012			<b>10. SPONSORING / MONITORING AGENCY REPORT NUMBER</b>	
<b>11. SUPPLEMENTARY NOTES</b>				
<b>12a. DISTRIBUTION / AVAILABILITY STATEMENT</b> Approved for Public Release; Distribution Unlimited			<b>12b. DISTRIBUTION CODE</b>	
<b>13. ABSTRACT (Maximum 200 Words)</b>  To ensure that the genome is not compromised, elaborate mechanisms of DNA repair are essential to the cell. The DNA Base Excision Repair (BER) pathway is responsible for the repair of alkylation and oxidative DNA damage. The short patch BER pathway begins with the simple glycosylase N-methylpurine DNA glycosylase (MPG), which is removes damaged bases such as N3-methyladenine, hypoxanthine, and 1,N6-ethenoadenine from the DNA. The resulting AP site is further processed by the other enzymes of the BER pathway to complete repair of the damaged DNA. Using mammalian expression vectors for stable and adenovirally-mediated transient overexpression, MPG has been overexpressed in two breast cancer cell lines. Constructs containing mitochondrial-targeted MPG (mito-MPG) were also made to direct MPG overexpression to the mitochondria. Overexpression of nuclear- and mitochondrial-targeted MPG dramatically sensitized MDA-MB231 breast cancer cells to the alkylating agent methylmethane sulfonate (MMS). This sensitivity directly correlated with an increased percentage of cells undergoing apoptosis in MPG overexpressing cells, and mito-MPG overexpression caused a significant number of cells to apoptose without drug treatment. We hypothesize that high levels of MPG remove increasing numbers of damaged and undamaged DNA bases, generating more AP sites and affecting the balance of the BER in tumor cells.				
<b>14. SUBJECT TERMS</b> breast cancer, DNA repair, gene therapy, base excision repair experimental therapeutics			<b>15. NUMBER OF PAGES</b> 17	
			<b>16. PRICE CODE</b>	
<b>17. SECURITY CLASSIFICATION OF REPORT</b> Unclassified Unclassified	<b>18. SECURITY CLASSIFICATION OF THIS PAGE</b> Unclassified Unclassified	<b>19. SECURITY CLASSIFICATION OF ABSTRACT</b> Unclassified Unclassified	<b>20. LIMITATION OF ABSTRACT</b> Unlimited	

## Table of Contents

Cover.....	1
SF 298.....	2
Table of Contents.....	3
Introduction.....	4
Body.....	5-11
Key Research Accomplishments.....	12
Reportable Outcomes.....	13
Conclusions.....	14-15
References.....	16
Bibliography.....	17

## INTRODUCTION:

To ensure that a cell's genome is not compromised, elaborate mechanisms of DNA repair are essential for both nuclear and mitochondrial DNA. The DNA Base Excision Repair (BER) pathway is responsible for the repair of alkylation and oxidative DNA damage. The short patch BER pathway beginning with the simple glycosylase includes four enzymes to repair alkylated bases: N-methylpurine DNA glycosylase (MPG), apurinic/aprimidinic endonuclease(Ape1/ref-1), DNA B-polymerase, and DNA ligase. MPG is responsible for the removal of damaged bases such as N<sup>3</sup>-methyladenine, hypoxanthine, and 1,N<sup>6</sup>-ethenoadenine from the DNA. The resulting AP site is further processed by the other members in the BER pathway resulting in the insertion of the correct nucleotide. MPG has been overexpressed in the breast cancer cell line, MDA-MB231 to test the hypothesis that overexpression of MPG will sensitize MDA-MB231 cells to the alkylating agent methylmethane sulfonate (MMS). As a future translational goal, gene transfer of MPG could result in increased breast cancer cells kill using lower doses of alkylating agents. This would minimize peripheral tissue damage, eliminate the need for bone marrow rescue or transplant, and potentially decrease the emergence of drug resistant tumor cells.

BODY:

With regard to the Statement of Work *Task 1*, the following items have been completed. The human MPG cDNA was subcloned into the pcDNA3 vector and transfected into the MDA-MB231 cells (2001 Annual Summary, Figure 1). The overexpression of MPG in the MDA-MB231 cells was confirmed by Northern and Western blot analysis (2001 Annual Summary, Figure 2). In addition to these analyses, an MPG activity assay was developed to demonstrate that the overexpressed protein was indeed functional (2001 Annual Summary, Figure 2, 3). To assay the cells for MPG activity, an oligo-based assay was developed similar to the well-established AP endonuclease oligo assay (1,2). The oligo was synthesized by Midland Reagent Co. (Midland, TX) and included an 1,N<sup>6</sup>-ethenoadenine. The endogenous levels of MPG were extremely low by Northern blot analysis and undetectable by Western blot analysis and MPG activity assay.

With regard to the Statement of Work, *Task 2*, the following items have been completed. The MDA-MB231 cells were treated with (methylmethane sulfonate) MMS and the cell survival was analyzed using the colony formation assay (2001 Annual Summary, Figure 4). The formula for cell survival was:

$$\frac{\text{average number of colonies}}{\text{number of cells plated}} * PE$$

$$\text{where } PE = \frac{\text{number of colonies of untreated MDA-MB 231 cells}}{\text{number of cells plated}}$$

This formula took into account the plating efficiency and any effects of overexpressing large amounts of MPG in these cells with and without drug treatment.

*Task 2* indicated that the cells would be challenged with more clinically relevant drugs such as mafosfamide and thiotepa. These drugs have not yet been used, but the crosslinking agent cisplatin has. Cisplatin generates lesions that are thought to be repaired by nucleotide excision repair (NER) (2001 Annual Summary, Figure 5). There were two new findings that made the use of cisplatin more relevant and of immediate interest. First, recent work by O'Connor et al. demonstrated that the MPG protein interacts with human Rad 23 homologs, hHR23A and B (3). The HR23 proteins, complexed with XPC (xeroderma pigmentosum C), have been shown to be involved in NER (4). The XPC-hHR23 association has been shown to stimulate XPC's activity (5), and the complex is thought to recognize the damaged DNA and

initiate the NER process in global genome repair (GGR) (6). The MPG – HR23 interaction links BER and NER pathways. Second, MPG protein has also been shown to bind to, but not excise cisplatin lesions. MPG binds with equal or greater affinity to cisplatin lesions as it does to commonly accepted substrates such as  $\epsilon$ A (7). Furthermore, repair of  $\epsilon$ A was inhibited in the presence of cisplatin adducts indicating that MPG's normal substrates were not being repaired. After treatment with cisplatin, the alkyl lesions that are generated endogenously would go unrepaired and result in mutagenesis and/or apoptosis due to the accumulation of unrepaired purines (7,8). MPG binding to cisplatin lesions would block the NER machinery from recognizing the lesion and decrease repair of the cisplatin adduct as well.

*Task 2* also proposed to analyze whether lower doses of drug effectively kill more breast cancer cells in the face of higher levels of MPG. As shown in the 2001 Annual Summary, Figure 4, MPG overexpression does cause breast cancer cells to be more sensitive to the alkylating agent MMS. MPG affected the viability of two cancer cell lines, MDA-MB231 (breast cancer) and Hey C2 (ovarian cancer) in response to the alkylating agent, MMS. To further this research, a mitochondrial target was added to MPG and enhanced cellular sensitivity upon overexpression of this mitochondrial-targeted MPG was observed. Repair systems for mitochondrial DNA (mtDNA) are just beginning to be investigated and better understood. Repair of mtDNA is crucial based on the findings of several laboratories that mtDNA suffers more damage than nuclear DNA after treatment with oxidative or alkylating agents (9-11). In addition to higher levels of damage, the mutation rate is 5 – 10 times greater in mitochondria than nuclei (12,13). Our hypothesis was that by targeting MPG to the mitochondria the breast cancer cells would be even further sensitized to alkylating agents. The cell survival curve is shown in the 2001 Annual Summary, Figure 6. This increase in sensitivity to alkylator was then analyzed for mechanism of cell death. Cells overexpressing MPG (231+nMPG) or mitochondrial-targeted MPG (231+mito-MPG) were evaluated for apoptotic death using two distinct assays: Annexin-V staining and cell morphology. Both assays concluded that there were more cells undergoing apoptosis in 231+nMPG and 231+mito-MPG cells after treatment with MMS compared to the vector control cells (231+pcDNA) (2001 Annual Summary, Figures 7, 8).

With regard to the Statement of Work *Task 3*, recombinant adenovirus containing human MPG and mitochondrial-targeted human MPG were constructed. In order to test the adenoviral system and prove its utility, the breast cancer-specific promoter was not included in these initial experiments. Human MPG and mito-MPG were subcloned into an adenoviral shuttle vector and

subsequently into the recombinant adenovirus serotype 5 genome under the control of a cytomegalovirus (CMV) promoter: Ad5CMV-MPG/mitoMPG (Figure 9). A downstream Internal Ribosomal Entry Site (IRES) controlling translation of the Enhanced Green Fluorescent Protein (EGFP) allows infected cells expressing increased levels of MPG to be distinguished by fluorescence microscopy based on co-overexpression of the EGFP marker. Recombinant adenovirus containing these modified genomes was produced by repeated plaque purification at the University of Iowa Gene Transfer Vector Core.

With regard to the Statement of Work *Task 4*, recombinant infectious adenovirus at  $1.5 \times 10^{11}$  plaque forming units per milliliter was used to infect MDA-MB231 and MDA-MB435 breast cancer cells. Efficiency of adenoviral infection was monitored by EGFP fluorescence in Fluorescence Activated Cell Sorting (FACS) analysis (Figure 10). Adenoviral experiments in MDA-MB435 cells were pursued in greater depth, and near-100% infection was achieved as demonstrated by EGFP expression in FACS (Figure 11). Overexpression in MDA-MB435 cells was confirmed by western analysis (Figure 12). Adenovirus is here demonstrated to be a highly efficient means of overexpressing exogenous protein in breast cancer cells. The use of breast cancer specific promoters to achieve tumor specific overexpression has not yet been completed, and remains as the next step for translational application of this research project.

# Ad5CMV

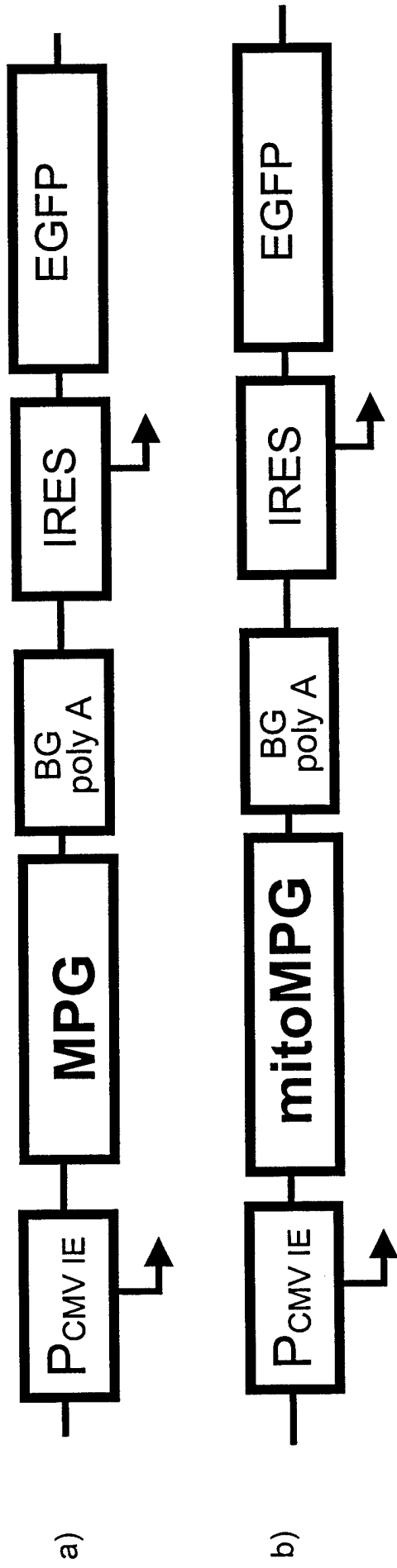
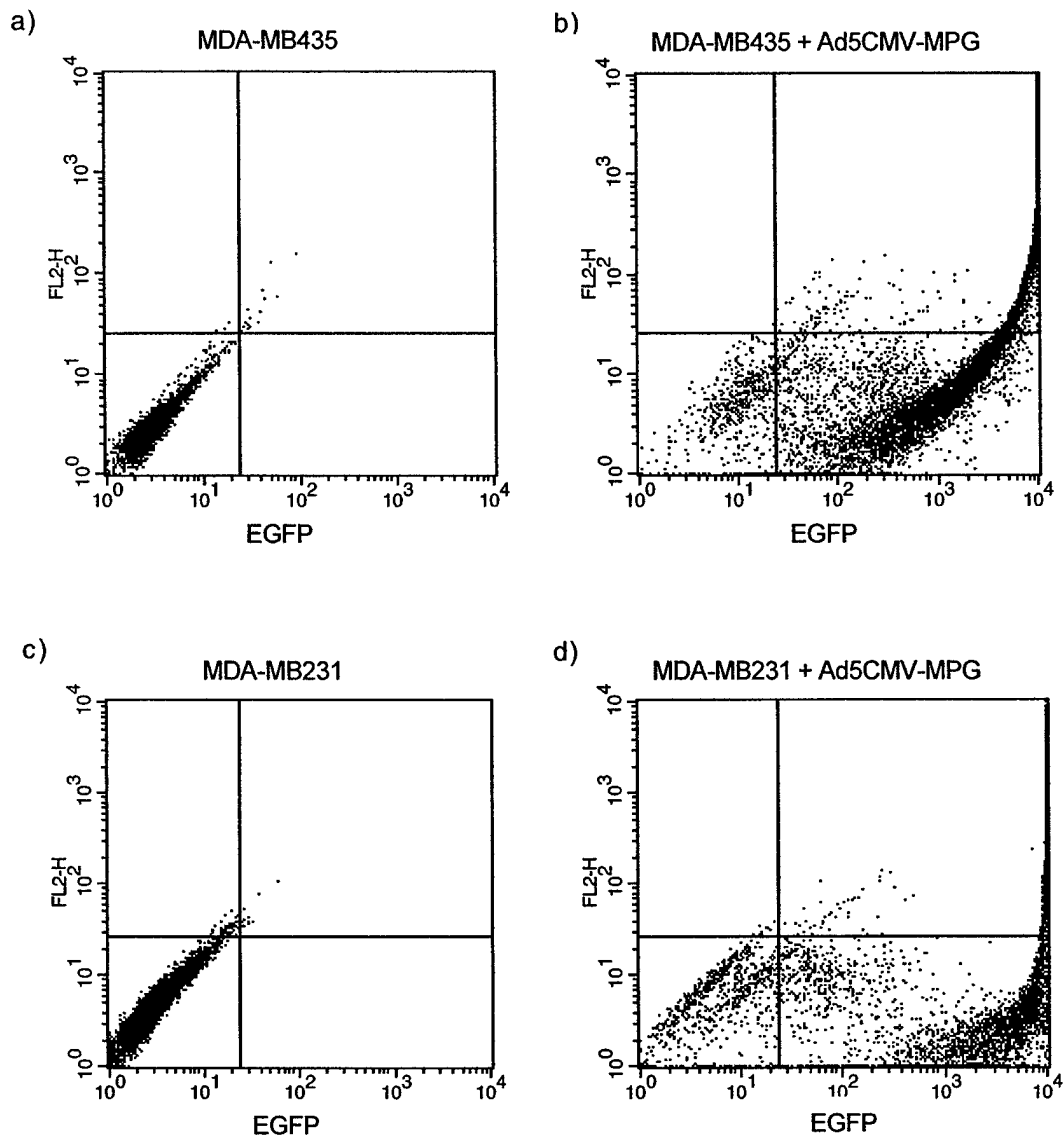
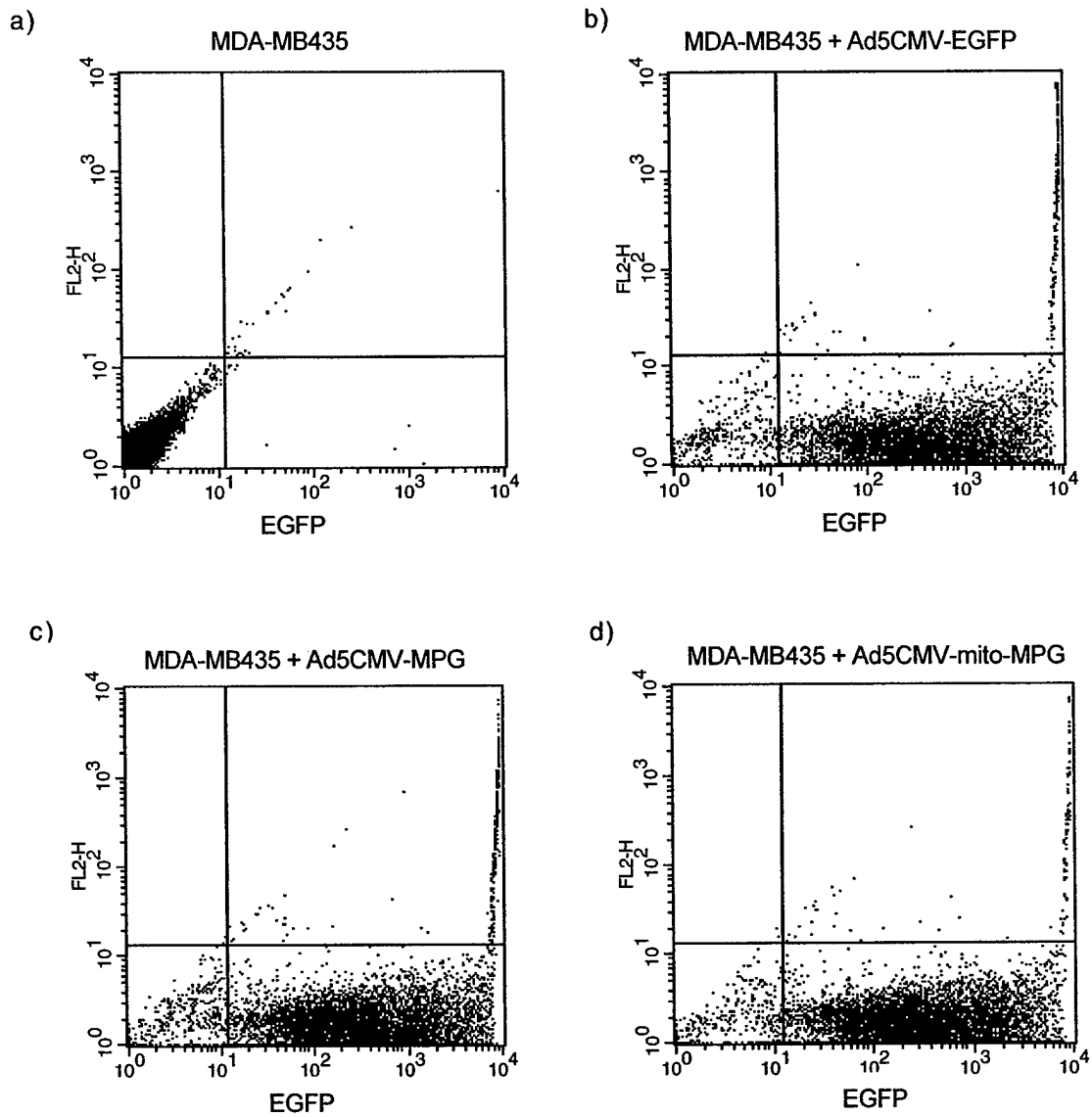

Figure 9. MPG Adenoviral Constructs  
(a) Ad5CMV-MPG  
(b) Ad5CMV-mito-MPG

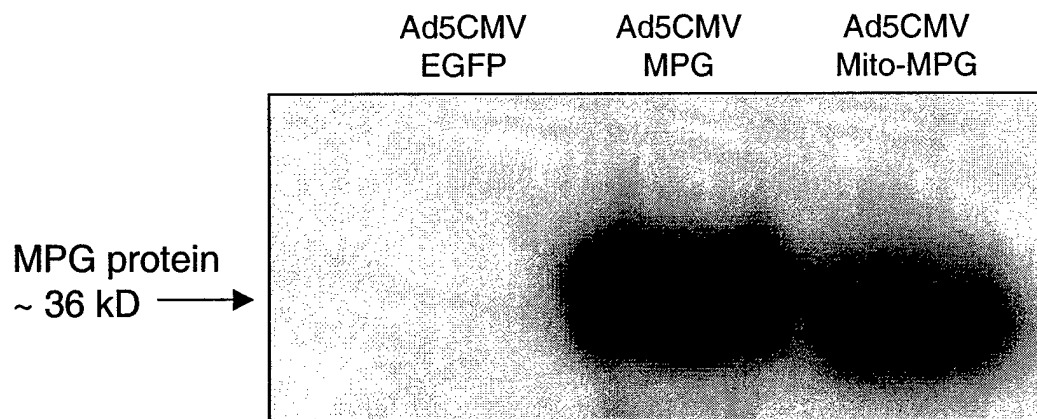

**Figure 10. MDA-MB435 and MDA-MB231 Breast Cancer Cells Infected with MPG-containing Recombinant Adenovirus**

Ad5CMV-MPG adenoviral infection efficiency was measured by FACS Analysis of EGFP levels (a) uninfected MDA-MB435 cells (b) Ad5CMV-MPG infection of MDA-MB435 cells gave 92.2% EGFP positive cells (c) uninfected MDA-MB231 cells (d) Ad5CMV-MPG infection of MDA-MB231 cells gave 82.3% EGFP positive cells



**Figure 11. MDA-MB435 Breast Cancer Cells Infected with Recombinant Adenovirus vector/MPG/mito-MPG**  
 Ad5CMV adenoviral constructs were used to infect MDA-MB435 cells at >95% infection efficiency as measured by FACS Analysis of EGFP levels. (a) uninfected (b) Ad5CMV-EGFP (c) Ad5CMV-MPG (d) Ad5CMV-mito-MPG



**Figure 12. Western Analysis of MDA-MB435 Breast Cancer Cells Infected with recombinant adenovirus vector/MPG/mito-MPG**  
Western blot analysis was performed with a monoclonal anti-MPG antibody.

## KEY RESEARCH ACCOMPLISHMENTS:

- Human MPG was subcloned into the pcDNA3.1 mammalian expression vector, sequence confirmed.
- Transfection of human MPG into MDA-MB231 and MDA-MB435 cell lines resulting in stable cell clones with confirmed overexpression of MPG mRNA and protein.
- An oligonucleotide-based activity assay was developed to detect increased levels of MPG activity in overexpressing cells.
- Increased MPG activity was demonstrated in MDA-MB231 and MDA-MB435 cells that were transfected with the pcDNA-MPG construct.
- MDA-MB231 cells overexpressing MPG were shown to be hypersensitive to the laboratory alkylating agent MMS and the chemotherapeutic agent cisplatin.
- A mitochondrial targeting sequence was added to the 5' end of MPG cDNA to create mito-MPG. The correct sequence was confirmed.
- Transfection of mito-MPG into MDA-MB231 and MDA-MB435 cell lines resulting in stable cell clones with confirmed overexpression of mito-MPG mRNA and protein. Higher levels of activity exclusively in mitochondrial cell fractions confirmed mitochondrial trafficking of active protein.
- MDA-MB231 cells overexpressing mito-MPG were shown to be hypersensitive to the laboratory alkylating agent MMS.
- MDA-MB231 cells overexpressing MPG and mito-MPG were shown to be undergoing apoptosis more readily upon treatment with the laboratory alkylating agent MMS.
- Lower doses of drug are useful for effectively killing more breast cancer cells that stably overexpress MPG and mito-MPG.
- MPG and mito-MPG were subcloned into a shuttling vector and moved into the Ad5 adenoviral genome for Adenoviral production.
- Adenovirus containing MPG or mito-MPG along with the marker Enhanced Green Fluorescent Protein (EGFP) was produced and purified.
- MPG and mito-MPG adenovirus was used to infect MDA-MB231 and MDA-MB435 cells. Overexpression was monitored by EGFP expression and confirmed by MPG protein levels. Adenoviral overexpression was shown to impart very high levels of MPG overexpression.

## REPORTABLE OUTCOMES:

- This award resulted in an oral presentation at the Midwest DNA Repair Symposium (Louisville, KY) in June 2000: "Sensitization of Breast Cancer Cells to Low Dose Chemotherapy Through Overexpression of the DNA Repair Protein N-Methylpurine DNA Glycosylase (MPG)"
- This award resulted in a poster presentation at the 2001 American Association for Cancer Research Annual Meeting (New Orleans, LA) and at the 2001 National M.D./Ph.D. Conference (Aspen, Co):

Melissa Limp-Foster, Mikael Rinne, Yi Xu, and Mark R. Kelley. "Imbalancing DNA Base Excision Repair (BER): Use of Nuclear and Mitochondrial-Targeted Human N-Methylpurine DNA Glycosylase (MPG) to Sensitize Breast Cancer Cells to Low Dose Chemotherapy".

- This award contributed to dissertation research that fulfilled Melissa Fishel's requirements for the degree of Doctor of Philosophy. Dr. Melissa Fishel is currently conducting post-doctoral research at the University of Chicago in Dr. Eileen Dolan's laboratory.

- Funding applied for and awarded based on this award:

BC011075 CDMRP. Predoctoral training grant, DOD. "Imbalancing the DNA Base Excision Repair Pathway Sensitizes Breast Cancer Cells to Chemotherapy and Modulates DNA Nucleotide Excision Repair: Potential for Combination Chemotherapy".

Predoctoral training grant, Komen Foundation. "Imbalancing DNA base excision repair sensitizes breast cancer cells to chemotherapy".

- This award resulted in a poster presentation at the 2002 American Society of Gene Therapy Annual Meeting (Boston, MA):

Mikael Rinne, David Caldwell, Melissa Fishel and Mark R. Kelley. "Imbalancing the DNA Base Excision Repair (BER) pathway Using Nuclear and Mitochondrial Targeted Human N-Methylpurine DNA Glycosylase (MPG/AAG): Sensitization of Breast and Ovarian Cancer Cells to Chemotherapy".

- This award resulted in the manuscript entitled "Imbalancing DNA Base Excision Repair (BER): Use of Nuclear and Mitochondrial-Targeted Human N-Methylpurine DNA Glycosylase (MPG) to Sensitize Breast Cancer Cells to Low Dose Chemotherapy", manuscript in preparation.

## CONCLUSIONS:

The human DNA BER pathway is responsible for the repair of alkylative and oxidative DNA damage. In BER, damaged bases are excised and replaced in a multi-step process initiated by a lesion-specific DNA glycosylase. The glycosylase MPG recognizes a number of diverse alkylated bases. MPG then removes the damage by hydrolyzing the N-glycosyl bond and releasing the defective base. The result of MPG activity is the generation of a cytotoxic and premutagenic abasic (AP) site that must be further processed by subsequent BER enzymes.

Based on data presented here, overexpression of nuclear- and mitochondrial-targeted MPG dramatically sensitized MDA-MB231 breast cancer cells to the laboratory alkylating agent MMS. These findings support the hypothesis that MPG overexpression in mammalian cells can imbalance BER in the recognition and removal of alkylation DNA damage. High levels of exogenously delivered MPG in effect "outrun" the downstream rate limiting step(s) that would incise the DNA backbone, remove the baseless residue, fill in the gapped DNA and ligate the repaired DNA strands. As DNA incurs alkylation damage, this imbalance gives rise to heightened levels of AP sites and/or gapped DNA, the unrepaired downstream products of BER. Accumulation of enough AP sites and gaps overwhelms the BER pathway and DNA repair is, in effect, inhibited. This impaired ability to repair the DNA results in increased mutagenesis, which, along with the persistence of unprocessed AP sites and gaps, leads to eventual cell death.

Cells overexpressing MPG in both nuclei and mitochondria were evaluated for the mechanism of cell death following treatment with MMS. Two different assays concluded that the number of cells undergoing apoptosis in 231+nMPG and 231+mito-MPG cells after MMS treatment were significantly higher than the number of apoptotic vector control cells. Of particular interest was the observation that 231+mito-MPG cells had a significant number of cells undergoing apoptosis without drug treatment. These high levels of MPG in the mitochondria are either acting on low-levels of damaged bases or on undamaged endogenous bases in the mitochondrial genome, creating AP sites and gaps and leading the cells down the apoptotic cascade. Further research is required to establish the mechanisms involved.

This research has additionally demonstrated the ability of MPG overexpression to contribute to tumor cell kill at lower doses of alkylation chemotherapy (2001 Annual Summary, Figure 4, 5 and 6). These findings are most significant for the problems of chemotherapeutic drug resistance and toxic side effects in the treatment of breast cancer patients. Drug resistance is the most important obstacle to therapeutic success in the medical management of patients with cancer. Higher drug doses would be able to circumvent many forms of drug

resistance, but most anticancer drugs have a very narrow therapeutic index that prohibits dose escalation to achieve more effective systemic drug concentrations. It is this requirement for dose reduction in the face of toxic side effects that is the other major limitation in anticancer drug administration. Any approach that can increase the effectiveness of existing chemotherapeutic regimens so that lower doses of drug can achieve better eradication of tumor cells will help medicine address the problems of drug resistance and side effects, and bring us closer to a cure.

## REFERENCES:

1. D. S. Chen, T. Herman, B. Demple, *Nucleic Acids Research* **19**, 5907-5914 (1991).
2. J. E. F. Sambrook, and T. Maniatis., *Molecular Cloning: A Laboratory Manual*, Cold Spring Harbor Laboratories (Cold Spring Harbor, NY, 1989).
3. F. Miao, Mohammed Bouziane, Reinhard Dammann, Chikahide Masutani, Fumio Hanaoka, Gerd P. Pfeifer, and Timothy R. O'Connor, *Journal of Biological Chemistry* **275**, 28433-38 (2000).
4. A. Balajee, and VA Bohr, *Gene* **250**, 15-30 (2000).
5. K. Sugasawa *et al.*, *Mol Cell Biol* **16**, 4852-61 (1996).
6. K. Sugasawa, JM Ng, C Masutani, S Iwai, PJ van der Spek, AP Eker, F Hanaoka, D Bootsma, JH Hoeijmakers, *Molecular Cell* **2**, 223-32 (1998).
7. M. Kartalou, Leona D. Samson, and John M. Essigmann, *Biochemistry* **39**, 8032-8 (2000).
8. B. P. Engelward, James M. Allan, Andrew J. Dreslin, Jack D. Kelly, Mavis M. Wu, Barry Gold, and Leona D. Samson, *Journal of Biological Chemistry* **273**, 5412-8 (1998).
9. F. M. a. B. V. H. Yakes, *PNAS* **94**, 514-9 (1997).
10. S. P. LeDoux *et al.*, *Carcinogenesis* **13**, 1967-1973 (1992).
11. V. Wunderlich, M. Schutt, M. Bottger, A. Graffi, *Biochem J* **118**, 99-109 (1970).
12. W. M. Brown, M. George, Jr., A. C. Wilson, *Proc Natl Acad Sci U S A* **76**, 1967-71 (1979).
13. D. C. Wallace, *Trends Genet* **5**, 9-13 (1989).
14. V. A. Bohr, and R. Michael Anson, *Journal of Bioenergetics and Biomembranes* **31**, 391-8 (1999).

## BIBLIOGRAPHY:

### PERSONNEL:

Melissa Limp-Foster (Trainee)

Mikael Rinne (Trainee)

### ABSTRACTS / PUBLICATIONS:

Melissa Limp-Foster, Mikael Rinne, Yi Xu, and Mark R. Kelley. Imbalancing DNA Base Excision Repair (BER): Use of Nuclear and Mitochondrial-Targeted Human N-Methylpurine DNA Glycosylase (MPG) to Sensitize Breast Cancer Cells to Low Dose Chemotherapy. AACR Annual Meeting, New Orleans, LA; March 2001.

Mikael Rinne, David Caldwell, Melissa Fishel and Mark R. Kelley. Imbalancing the DNA Base Excision Repair (BER) pathway Using Nuclear and Mitochondrial Targeted Human N-Methylpurine DNA Glycosylase (MPG/AAG): Sensitization of Breast and Ovarian Cancer Cells to Chemotherapy. ASGT Annual Meeting, Boston, MA; June 2002.

Melissa Limp-Foster, Young Rok Seo, Martin L. Smith and Mark R. Kelley. Imbalancing DNA BER: Use of Nuclear and Mitochondrial-Targeted Human N-Methylpurine DNA Glycosylase (MPG) to Sensitize Breast Cancer Cells to Low Dose Chemotherapy. Manuscript in preparation.