



O

H

S

D

Loop Group Parakeet Virtual Cable Concept Demonstrator

T. Dowsett, T.C. McNeill,
A.B. Reynolds and W.D. Blair

DSTO-TN-0446

DISTRIBUTION STATEMENT A:
Approved for Public Release -
Distribution Unlimited



Loop Group Parakeet Virtual Cable Concept Demonstrator

T. Dowsett, T.C. McNeill, A.B. Reynolds and W.D. Blair

**Information Networks Division
Information Sciences Laboratory**

DSTO-TN-0446

ABSTRACT

The Parakeet Virtual Cable (PVC) concept demonstrator uses the Ethernet Local Area Network (LAN) laid for the Battle Command Support System (BCSS) to connect the Parakeet DVT(DA) (voice terminal) to the Parakeet multiplexer. This currently requires pairs of PVC interface units to be installed for each DVT(DA). To reduce the cost of a PVC installation, the concept of a Loop Group Parakeet Virtual Cable (LGPVC) was proposed. This device was designed to replace the up to 30 PVC boxes and the multiplexer at the multiplexer side of a PVC installation. While the demonstrator is largely complete, testing has revealed an incomplete understanding of how to emulate the proprietary handshaking occurring between the circuit switch and the multiplexer. The LGPVC concept cannot yet be demonstrated.

RELEASE LIMITATION

Approved for public release

20021112 049

AQ F03-01-0146

Published by

*DSTO Information Sciences Laboratory
PO Box 1500
Edinburgh South Australia 5111 Australia*

Telephone: (08) 8259 5555

Fax: (08) 8259 6567

© Commonwealth of Australia 2002

AR-012-449

July 2002

APPROVED FOR PUBLIC RELEASE

Loop Group Parakeet Virtual Cable Concept Demonstrator

Executive Summary

Deployed headquarters in the land domain currently use two elements of local infrastructure: the Battle Command Support System (BCSS) and others have provided a Local Area Network (LAN) for data connectivity while Project Parakeet (trunk communications) uses 2-wire cable (WD-1/TT) to connect each DVT(DA) (voice terminal) to the Parakeet multiplexer/circuit switch. DSTO has developed a concept demonstrator for a 'Parakeet Virtual Cable' (PVC) to allow the Parakeet DVT(DA) connection to occur over the LAN thus saving resources and time to establish.

This current PVC concept requires pairs of PVC interface units (one for the DVT(DA)-ethernet interface and one for the ethernet-multiplexer interface) to be installed for each DVT(DA) (at approximately \$400 per unit). To reduce the cost of a PVC installation and to simplify the configuring and managing each of the PVCs, the concept of a Loop Group Parakeet Virtual Cable (LGPVC) was proposed.

The LGPVC concept eliminates and replaces a Parakeet Subscriber Access Multiplexer and bridges between a Eurocom loop group cable and the Ethernet. The LGPVC combines 30 PVC Ethernet packet streams into a loop group bit stream and vice versa. The Ethernet packet streams tunnel over the Ethernet infrastructure to PVC interface units that connect to their associated DVT(DA) terminals. The Eurocom loop group connects to the local circuit switch for call switching in the normal fashion. Thus the requirement for the Parakeet Subscriber Access Multiplexer and for multiple PVCs is removed. Instead, a single device performs the function.

The LGPVC concept demonstrator consists of a Linux workstation with an Ethernet and synchronous serial card. The LGPVC program uses a standard PC and a serial card to transmit a stream conforming to the Eurocom loop group format. This stream is created from the PVC packets received on the Ethernet from each DVT(DA) PVC interface device. Simultaneously, the LGPVC receives on the serial card a Eurocom loop group stream and transmits on the Ethernet the appropriate PVC packets to each DVT(DA) PVC interface device.

The demonstrator has been designed and tested at the Army School of Signals. While the Ethernet aspects of the design have been proven, testing has revealed a weakness in the current LGPVC design. The Eurocom standard does not define how to use the signalling time slot in a loop group. The manufacturers of the Parakeet loop group multiplexer are using the time slot for some form of handshaking between the parent circuit switch and the multiplexer. In the absence of a full understanding of this handshaking, the LGPVC cannot yet be demonstrated.

Authors

T. Dowsett

Thomas Dowsett was employed at DSTO as a vacation student. He has since completed an Electrical Engineering Degree from the University of New South Wales University College. He has become the RAEME Engineering Officer in Single Channel Radio Systems (SCRS) group of the Defence Materiel Organisation (DMO) Battlespace Communications Group.

T.C. McNeill

Tim McNeill was employed as a vacation student in the Network Architecture Group of the Defence Science and Technology Organisation's (DSTO) Communications Division. Tim is a graduate Computer Engineer and has been associated with companies such as Auspace Pty Ltd and CSIRO.

A.B. Reynolds

Information Networks Division

Alfred Reynolds is a Research Engineer in Network Architecture Group of the Defence Science and Technology Organisation's (DSTO) Information Networks Division having joined DSTO after completing a Systems Engineering Degree at the Australian National University. He is involved in research into tactical communication systems.

W.D. Blair

Information Networks Division

Bill Blair is a Senior Research Scientist in Network Architecture Group of the Defence Science and Technology Organisation's (DSTO) Information Networks Division having joined DSTO from the Australian Army. He is involved in research into networking for military strategic and tactical communications.

Contents

GLOSSARY

| | |
|--|----|
| 1. BACKGROUND | 1 |
| 2. CONCEPT | 1 |
| 3. REQUIREMENTS..... | 3 |
| 4. APPROACH TAKEN FOR THE CONCEPT DEMONSTRATOR..... | 4 |
| 4.1 System Overview | 4 |
| 4.2 Concept Demonstrator Hardware Block Diagram | 4 |
| 4.3 Concept Demonstrator Software..... | 5 |
| 5. TESTING..... | 6 |
| 6. POSSIBLE FUTURE WORK..... | 7 |
| 6.1 Resolution of the Signalling Channel Processing..... | 7 |
| 6.2 Improvements..... | 7 |
| 7. CONCLUSIONS | 7 |
| 8. REFERENCES..... | 9 |
| APPENDIX A: LGPVC OPTIONS CONSIDERED..... | 10 |
| A.1. Choice of Operating System | 10 |
| A.2. The Need for Speed | 10 |
| A.3. Ethernet card | 10 |
| A.4. Full Duplex Synchronous Serial Card | 10 |
| APPENDIX B: DETAILED INTERFACE INFORMATION..... | 12 |
| B.1. Loop Group Structure..... | 12 |
| B.2. PVC Ethernet Packet Structure..... | 12 |
| APPENDIX C: PROGRAMMING MODULE DESCRIPTION | 14 |
| C.1. Program Flow | 14 |
| C.2. File Dependences | 15 |
| C.3. Eth_interface.c and esccp.c | 16 |
| C.4. Plex.c and synplex.c | 17 |
| C.5. Lgpvc_threads.c | 17 |
| C.6. Lantest.c..... | 17 |
| C.7. Loopback.c..... | 17 |
| C.8. Lgpvc.c..... | 17 |
| C.9. Globals.c | 18 |

Glossary

| | |
|-------------------------------|--|
| AMI | Alternate Mark Inversion – the standard defining voltage and clocking used by the Parakeet system on the loop group in lieu of the commercial standard RS-422 |
| BCSS | Battlefield Command Support System – this seeks to computerise some headquarter functions and includes a 100-Base T Ethernet local area network |
| DVT(DA) | Digital Voice Terminal/Data Adaptor – a Parakeet telephone |
| EDA | Eurocom Data Adapter – converts between the commercial RS-422 standard and the military Eurocom standards (that use AMI) for synchronous links like the loop group |
| Eurocom | European military communications standards body that has standardised much of the system used in Parakeet |
| LGPVC | Loop Group Parakeet Virtual Cable |
| Loop group | A collection of 14 or 30 user connections (loops) that have been grouped together (multiplexed) onto a single cable |
| Parakeet | The project (and hence the system) providing Army's tactical trunk (ie telephony and wide area data) network |
| PVC | Parakeet Virtual Cable – a concept demonstrator that replaces a subscriber loop cable by using an Ethernet |
| Subscriber Access Multiplexer | The Parakeet device that interconnects a loop group cable and individual subscriber loop cables |
| RS-422 | Commercial standard for voltages and clocking for synchronous cables |
| Tadiran | Manufacturer of the circuit switches and multiplexers used in Parakeet |
| 100baseT Ethernet | A common commercial standard local area network and used by BCSS |

1. Background

Deployed headquarters in the land domain currently use two elements of local infrastructure: the Battle Command Support System (BCSS) and others have provided a Local Area Network (LAN) for data connectivity while Project Parakeet (trunk communications) uses 2-wire cable (WD-1/TT) to connect each DVT(DA) (voice terminal) to the Parakeet multiplexer/circuit switch¹. DSTO has developed a concept demonstrator for a 'Parakeet Virtual Cable' (PVC) (described in [1]) to allow the Parakeet DVT(DA) connection to tunnel² over the LAN thus saving resources and time to establish.

The current set up requires two PVC interface units for each DVT(DA), one connected to the DVT(DA), and one at the multiplexer or switch assembly. This limitation in the current use of PVCs results in an extra financial cost (PVC interface units cost approximately \$400 each) as well as difficulties in configuring and managing each of the PVC endpoints. To reduce the cost of a PVC installation and to simplify configuration and management, the concept of a Loop Group Parakeet Virtual Cable (LGPVC) was proposed. The LGPVC concept eliminates and replaces a Parakeet Subscriber Access Multiplexer and bridges between a Eurocom loop group cable and the Ethernet. Each DVT(DA) on the Ethernet would then need only one PVC device to connect to the shared LGPVC at the multiplexer.

This work has fundamentally been the output of two vacation students to DSTO along with support and guidance from DSTO staff members. The report is structured as follows. Section 2 provides a more detailed description of the LGPVC concept. Section 3 lists the requirements for an LGPVC. Section 4 describes the approach taken our development of an LGPVC concept demonstrator. Section 5 describes the testing of the device. Section 6 discusses possible future work including overcoming the signalling emulation problem that prevents the concept demonstrator from being fieldable. Section 7 concludes while Section 8 provides a glossary of terms.

2. Concept

The LGPVC concept sees a Parakeet Subscriber Access Multiplexer and individual WD-1/TT cable runs being replaced with a device that bridges between a Eurocom³ loop group cable and the headquarter Ethernet. In the current Parakeet system each

¹ Subscriber Access Multiplexer (Tadiran TAD-430) or Circuit Switch (Tadiran SW8500 or SW8000).

² Tunnelling is the transfer of encapsulated data over a communications medium.

³ Eurocom is a European military communications standards body that has standardised much of the system used in Parakeet, in this case defining the format of the loop group – an aggregation of (typically 30) users.

user is individually connected to a local multiplexer device that is in turn connected to a nearby circuit switch via a single cable using the Eurocom loop group standards.

The LGPVC combines 30 PVC Ethernet packet streams into a loop group bit stream and vice versa. The Ethernet packet streams tunnel over the Ethernet infrastructure to PVC interface units that connect to their associated DVT(DA) terminals. The Eurocom loop group connects to the local circuit switch for call switching in the normal fashion.

A commercial off-the-shelf (COTS) approach to LGPVC is shown in Figure 1. It was envisaged as comprising a workstation with an Ethernet network interface card and synchronous serial card. The LGPVC software would deal with interconnecting the Eurocom loop group bitstream and the multiple PVC packets. The system would use the standard software provided with the interface cards to connect to the physical cables. The loop group interface on the serial card would be converted to the electrical standards required by the Parakeet trunk system via a Eurocom Data Adapter (EDA). The figure also shows the stages of the communications chain the loop group takes from the LGPVC to the rest of the Parakeet network.

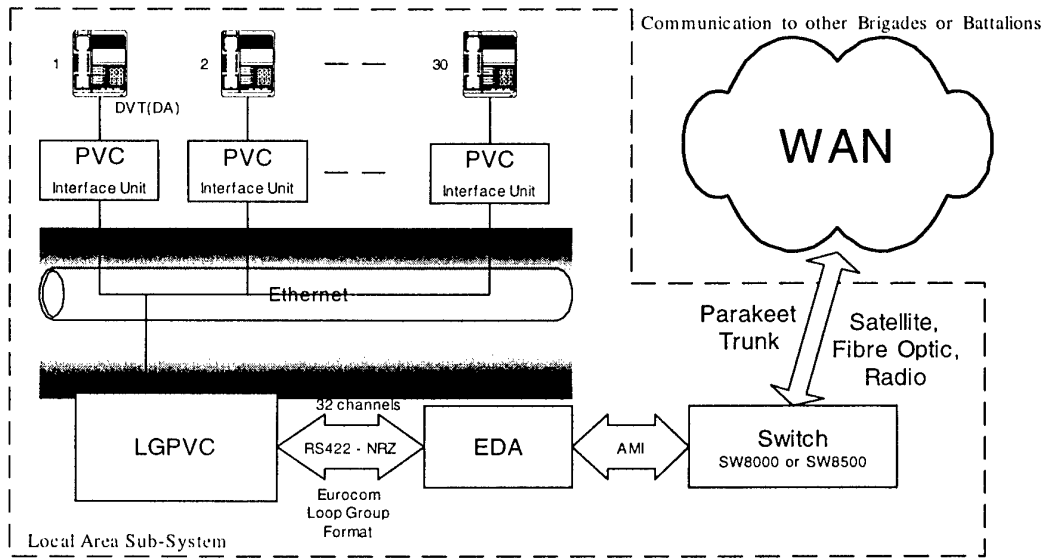

Figure 1: An Overall High Level Systems Schematic

An alternative approach would see a purpose built device encompassing the COTS aspects as well as the EDA function.

3. Requirements

The Eurocom loop group standard is silent on the use of the signalling time slot of the loop group. From observations of the bitstream, it is clear that the Parakeet circuit switch uses the signalling channel for some form of handshaking with the Parakeet loop group multiplexer. The signalling time slot is carrying a pattern that appears to reflect the state of connections to the multiplexer. Our limited understanding of the interchange on the signalling timeslot was obtained through advice from British Aerospace (Parakeet prime contractor) who had conducted some short tests on the loop group signalling. This testing was only static in nature (ie did not examine any dynamics of system start up or changes in switch/multiplexer configuration). The steady state signalling channel carried what appeared to be a 32 bit pattern reflecting the traffic channels connected to the multiplexer.

Noting that the Parakeet Project Office is reticent to endorse 'reverse engineering' of this proprietary signalling, the LGPVC concept demonstrator sought to progress by exploring two non-contentious approaches to establish this signalling pattern. We believed they had a good chance of convincing the circuit switch that an operational subscriber access multiplexer was connected over the loop group. The two alternative techniques examined were: firstly, to 'reflect' back the pattern received at the LGPVC; and, secondly, to allow the operator to configure a static pattern.

The formal requirements of a LGPVC are to:

- a. demultiplex a Eurocom loop group into individual DVT(DA) channels.
- b. generate PVC packet streams for each of the individual (demultiplexed) channels, which are then sent to each channels' PVC device via an Ethernet connection to the BCSS Ethernet LAN.
- c. receive (allowing for jitter⁴) PVC packets transmitted from each of the PVC devices.
- d. combine (multiplex) the received PVC channels to form a Eurocom loop group.
- e. provide appropriate activity to imitate the proprietary handshaking on the signalling channel.
- f. provide a full duplex RS-422 Non Return to Zero (NRZ) interface for connection to an EDA alternatively incorporate the EDA function.
- g. have the capability to produce a Eurocom loop group of both 512000 bits/s and 256000 bits/s, which corresponds to 30 and 14 DVT(DA) channels respectively.
- h. remain within the 35 ms time constraint for processing transmit and receive streams that interface to the EDA.
- i. reduce implementation costs to a level below that which the PVC concept can deliver.

⁴ Jitter is a random variation in transfer latency of data packets.

4. Approach Taken for the Concept Demonstrator

4.1 System Overview

The LGPVC concept demonstrator has been developed on a Linux based PC, with an Intel Pentium III 733 MHz processor, 128 Mbytes of RAM, 100BaseT Ethernet Card, and a synchronous full duplex serial card with PCI bus and RS-422 interface (FASTCOM ESCCP serial card described in [2]).

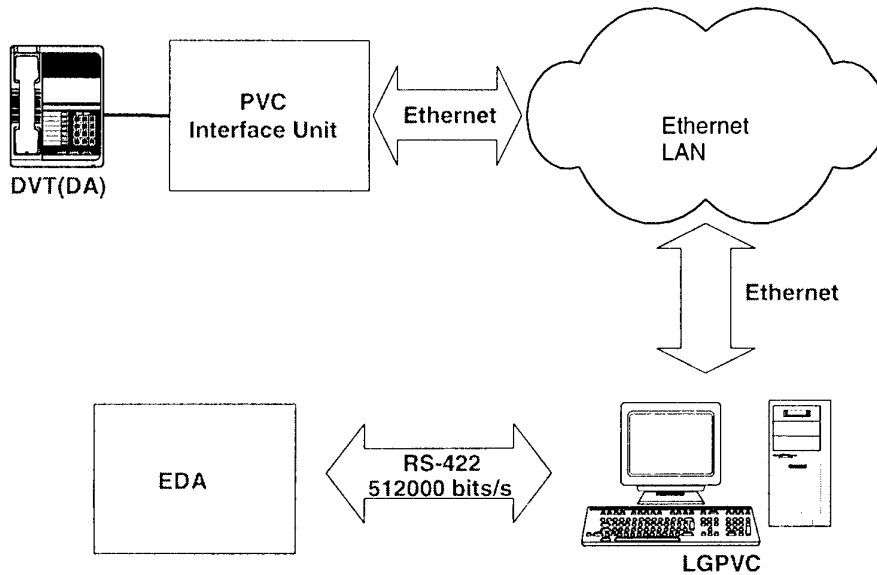

Figure 2: LGPVC Concept Demonstrator System Overview

More details on the hardware and software selected for the system can be found in Appendix A.

4.2 Concept Demonstrator Hardware Block Diagram

A simplified block diagram for the concept demonstrator is shown in Figure 3. There are two main interfaces: the Ethernet and the loop group. The Ethernet side sends and receives the packet stream via the 100baseT Ethernet card. The loop group side sends and receives the serial bit stream via the FASTCOM ESCCP serial card. In between the two interfaces is the software program, which performs the multiplexing and demultiplexing to convert between the two data formats.

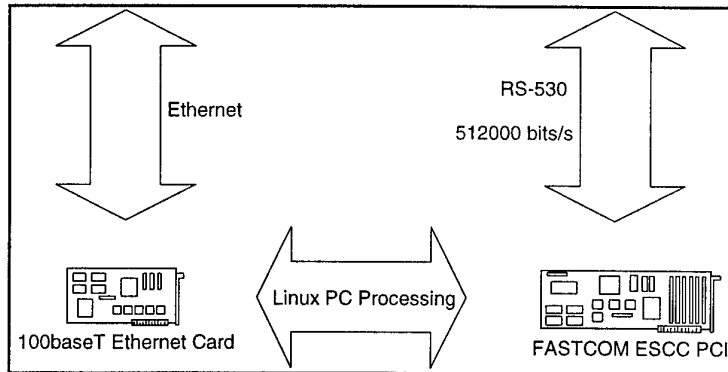

Figure 3: LGPVC Concept Demonstrator High Level Design Block Diagram

4.3 Concept Demonstrator Software

Except for the signalling channel element (discussed below), the software has been developed to working prototype status. The source code packages for the program can be obtained from the Network Architectures Group of Information Networks Division, Defence Science and Technology Organisation. The code is also available via the Australian Defence Restricted Network on:

<http://web-fhp.dsto.defence.gov.au/na-group/sourcecode/lgpvc/>
 (this URL is only valid for internal Australian Defence members).

An overview of the operation of the LGPVC program can be seen in the diagram below.

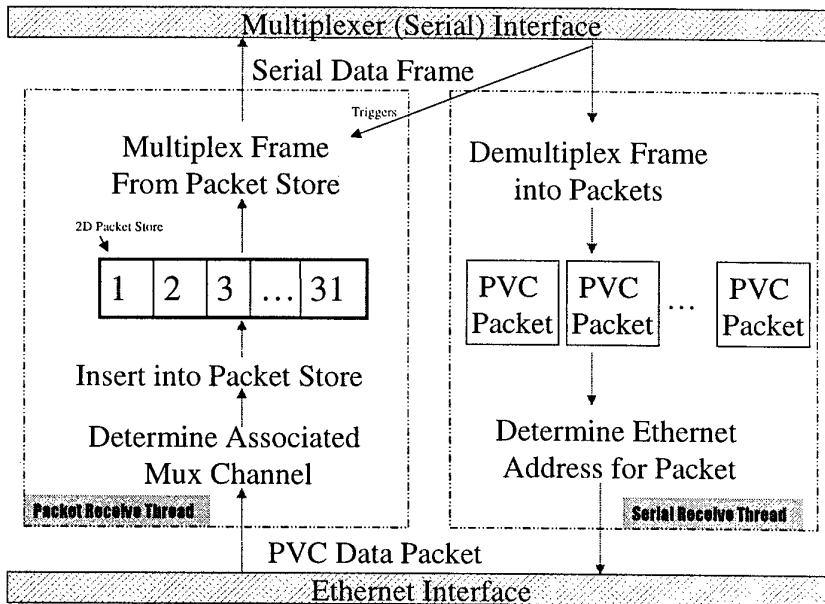

Figure 4 - Data flow schematic

Data flows into the software and interfaces to the hardware and external world from two directions. The top of the diagram shows the serial data flowing in and out of the system to the Parakeet multiplexer; the bottom of the diagram denotes the flow of Ethernet packets to and from PVC clients. There are two distinct yet linked directions to the flow of information, one up through the diagram and the other down from the top.

Packets initially arrive into the packet receive thread via the Ethernet interface of the LGPVC. The multiplexer channel for the packet is identified by its Ethernet address and it is placed into its corresponding packet store location. This function operates independently of the serial packet thread.

The serial interface collects frames of data that are 32 by 70 bytes in length. This corresponds to 30 PVC packets, one for each multiplexer channel (the remaining two channels are the synchronisation and signalling channel). Once received the serial receive thread triggers the packet receiving thread to transmit its packet store. It does this by inserting a synchronisation channel and a signalling channel (for the concept demonstrator using one of the two approaches described elsewhere) into the packet store structure. It then multiplexes and sends the resulting data out of the serial interface.

The serial receiver thread de-multiplexes the collected frame into its 30 constituent channels. It performs a reverse mapping of multiplexer channels to Ethernet addresses to create valid PVC packets and then sends the packets out of its Ethernet interface.

5. Testing

Testing of the concept demonstrator was broken down into 3 levels:

1. An independent test of the FASTCOM ESCCP Serial Card using a loop back cable to emulate the actual Parakeet switch. This tested the ability of the system to generate and receive a 512 kbps Eurocom trunk using the serial interface.
2. A test that extends the above by including the Ethernet side of the concept demonstrator system. This tested the ability of the system correctly perform the full range of transmit and receive functions for both interfaces as well as the linking between them.
3. A full system test, which involves attaching the concept demonstrator and PVC interface units to an actual Parakeet switching system and transferring data and voice through the system.

The concept demonstrator was successfully tested at levels 1 and 2 at DSTO.

Testing at level 3 was conducted at the Army School of Signals. Unfortunately, neither of the two approaches for emulating the subscriber access multiplexer was successful in fooling the circuit switch into believing an operational TAD-430 was installed on the loop group cable.

6. Possible Future Work

6.1 Resolution of the Signalling Channel Processing

Any future work on the LGPVC would require some greater understanding of the protocol used on the signalling channel. Since this interchange is occurring between two Tadiran devices there is a question of whether this breaches proprietary sensitivities. The authors would argue that this type of 'reverse engineering' is commonplace in the commercial sector, especially for interoperability purposes.

We believe that a successful emulation could be achieved (without being seen as 'reverse engineering' the TAD-430 device). Our efforts in providing an acceptable signalling channel were principally thwarted by lack of access to the requisite Parakeet devices. We believe that appropriate monitoring could promptly reveal the required handshaking on the signalling channel that would lead to a working LGPVC.

6.2 Improvements

As the current system is in a concept demonstrator phase of development some desirable features, such as double buffering, have been left for future developments. The implementation of the double buffering (which is implemented in the PVC) enables the LGPVC to efficiently handle late packets. This will improve the robustness of communications and provide better voice quality.

Currently the concept demonstrator uses only 1 (of the 2) serial ports provided by the FASTCOM serial card. It may be possible to use both ports to run 30 channels each. Running both ports means the PC would have its data-processing load doubled. The ability of a commodity based PC to process 60 channels simultaneously along with the double buffering and signalling channel improvements would need to be tested.

7. Conclusions

The LGPVC offers the promise of a useful extension to the PVC system, by improving the configuration and management of the Parakeet network interface component and by providing an overall cost reduction through the fielding of fewer PVCs and elimination of some Subscriber Access Multiplexers. This would improve the chances that the PVC concept could be used as a convergence technology for the Battlespace Communications System (Land).

The concept demonstrator is incomplete as the straightforward mechanism employed to generate the signalling channel handshaking failed to correctly emulate the TAD-430. Additional examination of the handshaking is required.

Defence should consider authorisation of this examination as a way of completing the concept demonstrator.

8. References

- [1] Blair W. D. and Reynolds A. B. (2001) *Parakeet Virtual Cable Concept Demonstrator*, DSTO-TR-1113, Electronics and Surveillance Research Laboratory, Salisbury, South Australia.
- [2] Commtech@southwind.net (1999) *FASTCOM: ESCC-P Hardware Reference Manual (PDF)*, www.commtech-fastcom.com/escpci.pdf
- [3] Stones R. and Matthews N (1999) *Beginning Linux Programming*, 2nd Edition Wrox Press Ltd, Birmingham, UK.

Appendix A: LGPVC Options Considered

A.1. Choice of Operating System

The Linux operating system was chosen as the development platform because, unlike Windows 98/NT/2000, it has an acceptable soft real time⁵ performance [3]. The real time capability of the chosen development platform is critical because of the need to meet the latency requirements of the system.

A secondary reason for the selection of the Linux operating system was to exploit the corporate knowledge gained in the development of the PVC. The PVC was developed using the 16MHz Motorola MC68EZ328 DragonBall Microprocessor running Linux. Proven software code was used for the PVC, and as a result, it can be reused for the LGPVC.

A.2. The Need for Speed

The overall system has a maximum time constraint of 35ms, as this is the length of audio data contained in each ethernet packet (and so represents the average time between the arrival of consecutive packets). The processor speed was selected to allow the processing of transmit and receive streams within this time constraint.

A.3. Ethernet card

Each of the PVC devices generates a 16 kbit/s Ethernet stream, not including packet overheads. With each LGPVC stream connected to up to 30 PVCs, the Ethernet card must be able to handle greater than 512000 bits/s. To overcome a potential bottleneck, a 100baseT Ethernet card was selected.

A.4. Full Duplex Synchronous Serial Card

The Eurocom standard and the interface to the EDA dictate the serial card's specifications. The specifications for the serial card are as follows:

- Linux Driver (Kernel version 2.2.12)
- PCI bus
- RS-422, Full duplex, synchronous
- Capable of 512000 and 256000 bits/s bit rates

⁵ Soft real-time is defined as real-time performance levels without the guarantees possible in a full real-time system. A computer operating system that delivers low latencies to programs is considered soft real-time.

- Raw transmit and receive interface

A search revealed several candidate cards, which were typically marketed as communications controllers rather than serial cards. However, most of these cards failed to meet the requirement of providing a supported Linux driver.

The card finally selected was the FASTCOM ESCC -PCI card from Commtech. The card had a proven history with BAE Systems in logging a Eurocom loop group. Commtech also provided a Linux driver, which is suitable for Red Hat 6.1.

Appendix B: Detailed Interface Information

B.1. Loop Group Structure

The Eurocom standard enables the simultaneous transmission of up to 30 channels by interleaving the channels into a single bitstream. The loop group bitstream, which is transferred on the trunk network, has the following structure (assuming 30 channel system):

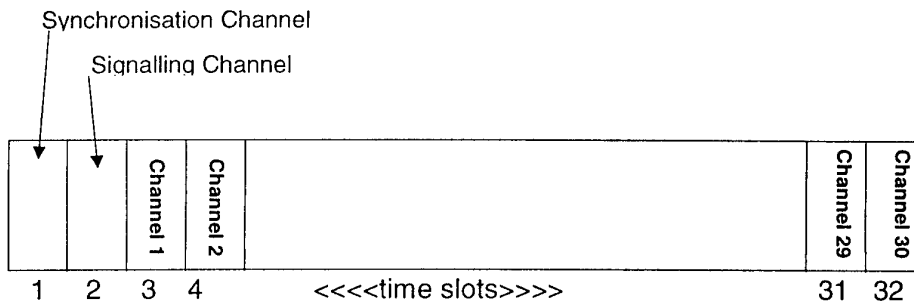

Figure 5: Sub-Structure of the Eurocom Loop Group

The loop group uses Time Division Multiplexing (TDM) with each channel allocated a one bit time slot within a TDM frame. The demultiplexing device uses the synchronisation channel time slot as a reference point for identifying each of the 32 bit groups. Once synchronisation is achieved at the demultiplexer, a particular channel's bit can be read every 32 bits. When the bit stream is interrupted (by a bit slip caused by inaccurate clocking sources or if there is a connection failure) a defined pattern appearing in the synchronisation time slot will allow the system to resynchronise itself.

B.2. PVC Ethernet Packet Structure

The PVC Ethernet packets use a custom packet structure defined in [1], which defines the required attributes of the packet's contents. Below is a breakdown schematic of the PVC packet:

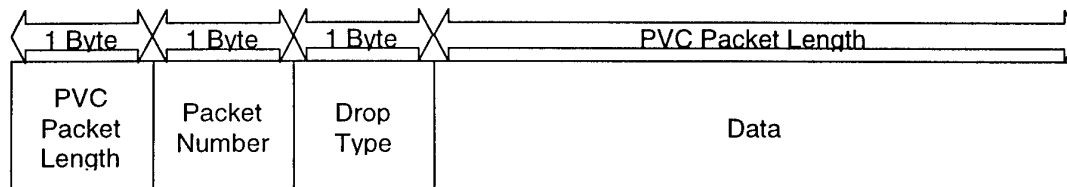

Figure 6: Structure of PVC Ethernet Packet Payload

To maintain the Ethernet stream, the PVC packets need to be small enough to allow the strict timing requirements of the system to be met. There are several determining factors when deciding the PVC packet size. The minimum data payload size for an Ethernet packet is 46 bytes. The need to keep the latency low and the chips that are used in the PVC produced an upper bound on the packet size. The PVC chips have a relatively small restriction on linear buffers (of 140 bytes), the dual buffering requirement resulted in data payload packet sizes being set to 73 bytes (70 bytes of audio data).

Appendix C: Programming Module Description

This appendix discusses the general program structure.

As the LGPVC has some strict hardware requirements, the performance of the Ethernet and serial interface software modules is very important. Figure 7, shows the way these modules interface the source code files with their appropriate hardware cards.

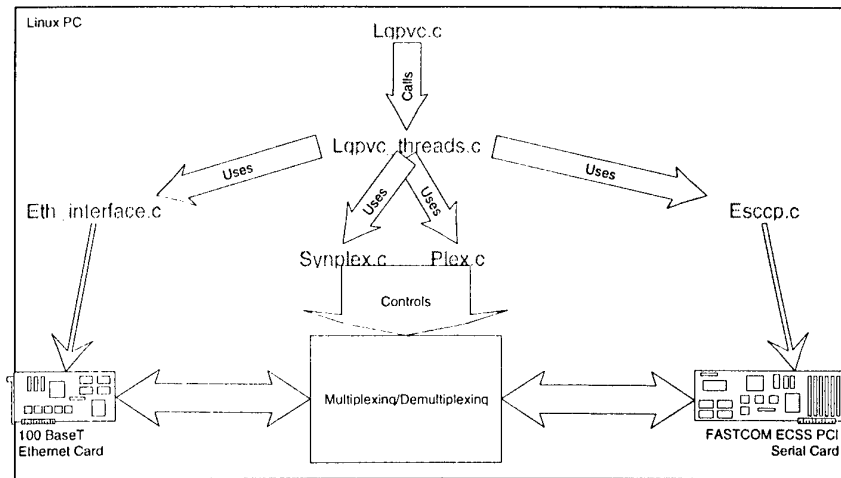

Figure 7: Structure of Hardware and Software Interfacing

The system is controlled via the core program in the file `lgpvc.c`. This module calls `lgpvc_threads.c` that then starts a number of detached threads. These threads call functions from `Eth_interface.c`, `Synplex.c` and `Esccp.c` to perform the actual multiplexing and demultiplexing.

`Eth_interface.c` provides the software interface to the hardware Ethernet card. Similarly, `Esccp.c` provides the software interface to the hardware FASTCOM serial card.

C.1. Program Flow

The path a segment of voice data takes through the PVC/LGPVC communications system is mapped out as follows. This is a technical description of the method covered in 4.3, covering only one of the data flow directions.

- The LGPVC receives a new packet from an associated PVC device and places the data into a storage buffer.

- In the transmit thread a comparison between the buffered packet's Ethernet address and the Ethernet addresses in the LGPVC channel-mapping table is performed. When a match is found the data is copied into the correct channel of a two-dimensional buffer structure (one linear, PVC packet sized buffer per channel).
- The transmit thread then waits for a signal from the receive thread, which is generated when a buffer is read from the serial card. This effectively synchronises the Ethernet data processing to the 'heart beat' produced by the constant bit rate loop group data stream received by the serial card.
- After the transmit thread has been signalled, a synchronisation and an appropriate signalling channel (currently using one of the two approaches) is added to the two-dimensional structure. This is done to produce a valid Eurocom loop group data stream.
- The content of this structure is then multiplexed into a Eurocom loop group format.
- This loop group is passed to the serial card's transmit buffer.
- This data stream travels to the EDA where it is converted into an Alternate Mark Inversion (AMI) signal.
- This signal is received by the Parakeet switch, which forwards the voice bitstream to the appropriate destination.

C.2. File Dependences

Figure 8 below, shows the structure, interaction and dependences of the coding modules.

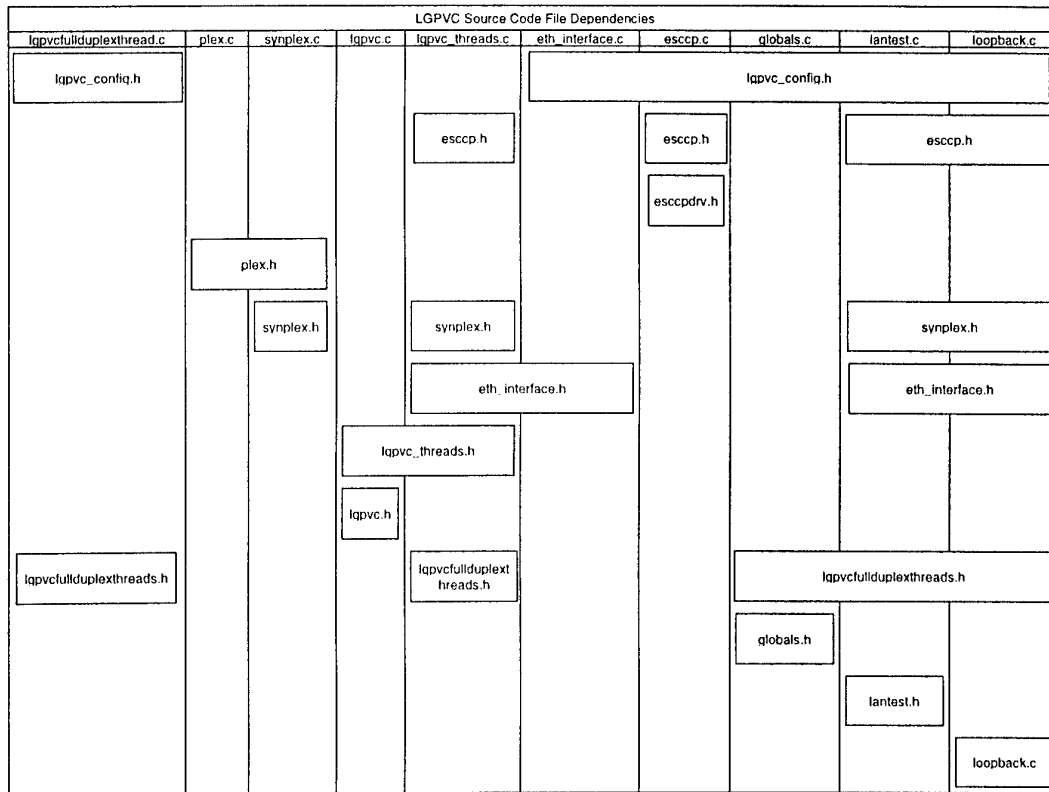

Figure 8: Source Code File Dependencies

There are ten source code files and twelve header files. Each source file has an associated header file. The header file, lgpvc_config.h, contains all the relevant configuration information for the LGPVC. The header file esccpdrv.h, which was provided by Commtech, contains the required data structures and definitions needed for the FASTCOMM ESCC PCI serial card.

C.3. Eth_interface.c and esccp.c

There are two modules that provide the means of using the Ethernet and Serial cards, which are eth_interface.c and esccp.c respectively. The module eth_interface.c contains methods for initialising the Ethernet card and getting and sending PVC Ethernet Packets, while the module esccp.c contains methods for initialising the FASTCOMM synchronous serial card and providing card status.

C.4. Plex.c and synplex.c

The modules `plex.c` and `synplex.c` are used to multiplex and demultiplex buffers. `Plex.c` performs bit interleaving and multiplexing of a channel buffer which contains data for a specific number of channels of a set length. `Plex.c` also performs bit deinterleaving and demultiplexing of a buffer into a number of channels buffers of equal length. `Synplex.c` is a synchronised version of `plex.c` and provides extra functionality that allows the Eurocom synchronisation/alarm channel to be found and the remapping of the channel buffers so the synchronisation channel, if found, corresponds to channel 0 of the channel buffers.

C.5. Lgpvc_threads.c

The module `lgpvc_threads.c` provides some of the methods and the threads that use `synplex.c`, `escpc.c` and `eth_interface.c` to provide the functionality required so that the LGPVC can satisfy its requirements. Testing and run time capability for the LGPVC is provided through functions that use separate transmit and receive threads. Because of faults with the FASTCOM driver, a separate watchdog thread was created to monitor the condition of the FASTCOM card. If the card fails to operate correctly the watchdog thread performs a reset procedure that allows the card to recommence correct operation.

C.6. Lantest.c

This module contains three out the four threads that run the second level testing scheme. The three threads call `synplex.c`, `escpc.c` and `eth_interface.c` function to transmit and receive both the Ethernet packets and the Eurocom loop group.

C.7. Loopback.c

The `loopback.c` module contains the threads and functions that perform the level 1 test. From these threads the output files are read, multiplexed, transmitted, received, demultiplexed and written to the input files.

C.8. Lgpvc.c

Finally a driver program, `lgpvc.c`, is used to configure, test and run the LGPVC concept demonstrator. `Lgpvc.c` provides a command line interface, which allows a user to configure which FASTCOM port will be used and the PVC MAC addresses. It also allows three levels of testing: A physical loopback test for the FASTCOM card, an

extended test which uses the actual DVT(DA) and PVC setup to test the Ethernet side as well, and a live version of the program.

C.9. Globals.c

The module globals.c is included in the LGPVC program to allow global variables to be shared between multiple threads and functions. Although global variables are less efficient and harder to maintain than parameter passing, the current concept demonstrator only requires a working version, not a fully optimised software solution.

DISTRIBUTION LIST

Loop Group Parakeet Virtual Cable Concept Demonstrator

T. Dowsett, T.C. McNeill, A.B. Reynolds and W.D. Blair

AUSTRALIA

DEFENCE ORGANISATION

Task Sponsor DGC4

S&T Program

Chief Defence Scientist

FAS Science Policy shared copy

AS Science Corporate Management

Director General Science Policy Development

Counsellor Defence Science, London (Doc Data Sheet)

Counsellor Defence Science, Washington (Doc Data Sheet)

Scientific Adviser to MRDC Thailand (Doc Data Sheet)

Scientific Adviser Joint

Navy Scientific Adviser (Doc Data Sheet and distribution list only)

Scientific Adviser - Army (Doc Data Sheet and distribution list only)

Air Force Scientific Adviser

Director Trials

Chief of Information Networks Division (Doc Data Sheet)

Research Leader, MIN Branch

Head Network Architectures Group

Network Architectures Group Fern Hill Park

P. Blackmore

W.D. Blair

A.B. Reynolds

T. Dowsett

T.C. McNeill

J. Ball

Research Leader, Land Systems

DSTO Library and Archives

Library Edinburgh

Australian Archives

Library Canberra

Capability Development Division

Director General Maritime Development (Doc Data Sheet only)

Director General Land Development

Army

Land Headquarters: S01 CISEW and Staff Officer Science ((2 Copies)
ABCA Office, Puckapunyal (4 copies)
SO (Science), DJFHQ(L), MILPO Enoggera, Queensland 4051
NAPOC QWG Engineer NBCD c/- DENGERS-A, HQ Engineer Centre Liverpool
Military Area, NSW 2174 (Doc Data Sheet only)
Army School of Signals (3 copies as follows :)
 Headquarters
 Development Wing
 SGT Frank Pokorra

Intelligence Program

DGSTA Defence Intelligence Organisation
Manager, Information Centre, Defence Intelligence Organisation

Acquisitions Program

SPO (Director) Battlespace Communications Systems
PD JP65
PD JP2072
PD BCSS
PD JP8001
Land Engineering Agency (2 Copies: Library and G. Lampard)

UNIVERSITIES AND COLLEGES

Australian Defence Force Academy
 Library
 Head of Aerospace and Mechanical Engineering
Serials Section (M list), Deakin University Library, Geelong, VIC
Hargrave Library, Monash University (Doc Data Sheet only)
Librarian, Flinders University

OTHER ORGANISATIONS

National Library of Australia
NASA (Canberra)
AusInfo

OUTSIDE AUSTRALIA

INTERNATIONAL DEFENCE INFORMATION CENTRES

US Defense Technical Information Center, 2 copies
UK Defence Research Information Centre, 2 copies
Canada Defence Scientific Information Service, 1 copy
NZ Defence Information Centre, 1 copy

ABSTRACTING AND INFORMATION ORGANISATIONS

Library, Chemical Abstracts Reference Service
Engineering Societies Library, US
Materials Information, Cambridge Scientific Abstracts, US
Documents Librarian, The Center for Research Libraries, US

INFORMATION EXCHANGE AGREEMENT PARTNERS

Acquisitions Unit, Science Reference and Information Service, UK
Library - Exchange Desk, National Institute of Standards and Technology, US

SPARES (5 copies)

Total number of copies: 64

| | | | | | |
|---|-----------------------------|-----------------------------|---|---|-------------------------------|
| DEFENCE SCIENCE AND TECHNOLOGY ORGANISATION DOCUMENT CONTROL DATA | | | | 1. PRIVACY MARKING/CAVEAT (OF DOCUMENT) | |
| 2. TITLE Loop Group Parakeet Virtual Cable Concept Demonstrator | | | 3. SECURITY CLASSIFICATION (FOR UNCLASSIFIED REPORTS THAT ARE LIMITED RELEASE USE (L) NEXT TO DOCUMENT CLASSIFICATION) Document (U) Title (U) Abstract (U) | | |
| 4. AUTHOR(S) T. Dowsett, T.C. McNeill, A.B. Reynolds and W.D. Blair | | | 5. CORPORATE AUTHOR Information Sciences Laboratory PO Box 1500 Edinburgh South Australia 5111 Australia | | |
| 6a. DSTO NUMBER DSTO-TN-0446 | | 6b. AR NUMBER AR-012-419 | 6c. TYPE OF REPORT Technical Note | | 7. DOCUMENT DATE July 2002 |
| 8. FILE NUMBER E8709/9/12 | 9. TASK NUMBER JNT99/141 | 10. TASK SPONSOR DGC4 | 11. NO. OF PAGES 8 | | 12. NO. OF REFERENCES 3 |
| 13. URL on the World Wide http://www.dsto.defence.gov.au/corporate/reports/DSTO-TN-0446.pdf | | | 14. RELEASE AUTHORITY Chief, Information Networks Division | | |
| 15. SECONDARY RELEASE STATEMENT OF THIS DOCUMENT <i>Approved for public release</i> | | | | | |
| OVERSEAS ENQUIRIES OUTSIDE STATED LIMITATIONS SHOULD BE REFERRED THROUGH DOCUMENT EXCHANGE, PO BOX 1500, EDINBURGH, SA 5111 | | | | | |
| 16. DELIBERATE ANNOUNCEMENT No Limitations | | | | | |
| 17. CITATION IN OTHER DOCUMENTS Yes | | | | | |
| 18. DEFTEST DESCRIPTORS Parakeet project, Mobile communication systems. | | | | | |
| 19. ABSTRACT The Parakeet Virtual Cable (PVC) concept demonstrator uses the Ethernet Local Area Network (LAN) laid for the Battle Command Support System (BCSS) to connect the Parakeet DVT(DA) (voice terminal) to the Parakeet multiplexer. This currently requires pairs of PVC interface units to be installed for each DVT(DA). To reduce the cost of a PVC installation, the concept of a Loop Group Parakeet Virtual Cable (LGPVC) was proposed. This device was designed to replace the up to 30 PVC boxes and the multiplexer at the multiplexer side of a PVC installation. While the demonstrator is largely complete, testing has revealed an incomplete understanding of how to emulate the proprietary handshaking occurring between the circuit switch and the multiplexer. The LGPVC concept cannot yet be demonstrated. | | | | | |