

DOT/FAA/AM-02/16

Office of Aerospace Medicine
Washington, DC 20591

Access-To-Egress I: Interactive Effects of Factors That Control the Emergency Evacuation of Naïve Passengers Through the Transport Airplane Type-III Overwing Exit

Garnet A. McLean
Cynthia L. Corbett
Kenneth G. Larcher
Jerry R. McDown
David A. Palmerton
Keith A. Porter
Robert M. Shaffstall
Civil Aerospace Medical Institute
Federal Aviation Administration
Oklahoma City, OK 73125

Rita S. Odom
Advancia Corporation
655 Research Parkway
Oklahoma City, OK 73104

August 2002

Final Report

This document is available to the public
through the National Technical Information
Service, Springfield, VA 22161.



U.S. Department
of Transportation
**Federal Aviation
Administration**

DISTRIBUTION STATEMENT A
Approved for Public Release
Distribution Unlimited

20021126 083

N O T I C E

This document is disseminated under the sponsorship of the U.S. Department of Transportation in the interest of information exchange. The United States Government assumes no liability for the contents thereof.

Technical Report Documentation Page

1. Report No. DOT/FAA/AM-02/16		2. Government Accession No.		3. Recipient's Catalog No.	
4. Title And Subtitle Access-To-Egress I: Interactive Effects of Factors That Control the Emergency Evacuation of Naïve Passengers Through the Transport Airplane Type-III Overwing Exit				5. Report Date August 2002	
				6. Performing Organization Code	
7. Author(s) (¹) McLean, GA; Corbett, CL; Larcher, KG; McDown, JR; Palmerton, DA; Porter, KA; Shaffstall, RM; and (²) Odom, RS				8. Performing Organization Report No.	
9. Performing Organization Name and Address (1) FAA Civil Aerospace Medical Institute P.O. Box 25082 Oklahoma City, OK 73125				(2) Advancia Corporation 455 Research Parkway Oklahoma City, OK 73104	
12. Sponsoring Agency Name and Address Office of Aerospace Medicine Federal Aviation Administration 800 Independence Ave. Washington, DC 20591				11. Contract or Grant No.	
				13. Type of Report and Period Covered	
15. Supplemental Notes This work was performed under task AM-B-01-PRS-93.				14. Sponsoring Agency Code	
16. Abstract <p>Simulated emergency evacuations were conducted from a narrow-body transport airplane simulator through a Type-III overwing exit. The independent variables were passageway configuration, hatch disposal location, subject group size, and subject group motivation level. Additional variables of interest included individual subject characteristics, i.e., gender, age, waist size, and height, all of which had been shown in previous studies to significantly affect emergency egress. Participants were restricted to those who had no previous emergency evacuation (research) history. The dependent variables of interest included hatch operation time and the time for individual subjects to egress.</p> <p>Evacuation trials were conducted with 48 groups of either 30, 50, or 70 subjects per group, for a total of 2,544 subject participants. Each subject group completed 4 evacuation trials, totaling 192 evacuations. Results reported for hatch operation time include data from all trials, since each trial had a different, naïve hatch operator. The egress time results include data only from each group's first evacuation trial in which every subject was naïve. Significant main effects of hatch disposal location on both Exit-Ready-To-Use Time ($p < .004$) and First-Person-Out Time ($p < .008$) were revealed, without effects of the other variables. Significant main effects on individual subject egress time were found for waist size ($p < .0001$), gender ($p < .0001$), and age ($p < .0001$). A small, but significant, main effect was also found for passageway configuration ($p < .001$), which was confounded by improper hatch disposal and a between-groups imbalance in individual subject characteristics. This situation produced a significant (4-way) passageway configuration by hatch disposal location by subject group density by subject group motivation level interaction effect ($p < .008$).</p> <p>The findings replicate prior research showing that passageway configuration has only minimal effects on emergency egress, as long as ergonomic minimums are respected. In contrast, differences in the physical characteristics of individual subjects produce large differences in emergency evacuation performance, as does subject naïveté.</p>					
17. Key Words Aircraft Evacuation, Passageway Configuration, Hatch Operation, Competitive Egress, Individual Subject Characteristics				18. Distribution Statement Document is available to the public through the National Technical Information Service, Springfield, VA 22161	
19. Security Classif. (of this report) Unclassified		20. Security Classif. (of this page) Unclassified		21. No. of Pages 40	
				22. Price	

ACKNOWLEDGMENTS

The authors heartily acknowledge the untiring efforts of those who gave so generously of their time and energy toward the success of this project. The dedication each of them displayed is a tribute to the professionalism embodied in the personnel of the Civil Aerospace Medical Institute and their willingness to assist almost any time or day. Among those who contributed, special thanks go to our research support staff:

Tracie Allison	Joe Beasley	Rick Butler	Patricia Calvert
Kristi Craft	Chuck DeJohn	David DeSelms	Rick DeWeese
Dave Dyer	Jerrod Epple	Wilma Fairman	Van Gowdy
Rusty Lewis	Edward Matheke	Ronnie Minnick	Becky Orman
Donna Potter	Bryan Provine	Lori Samuel	Steve Veronneau
James Whinnery	Greg Winters	Alex Wolbrink	Kathi Wood

The project could also not have been accomplished without many contract personnel, who recruited and managed our subjects, helped out with conducting the evacuation trials, and maintained the evacuation simulator, which was under constant threat of demolition by the onslaught of zealous evacuees. Those in our debt include:

Jason Garvin	Suanne Hanson	Linda Hoover	John Howard
Julianne Jacks	Jerry Johnson	Jim King	Lorri King
Robert McCawley	Heather Munn	Dave Ruppel	Stephanie Sanders
Buck Walker	Vicky Wilson		

The staff of the Continental Airlines Inflight Training department were also invaluable to the success of the project. Without their support, especially the flight attendants who performed so admirably in the evacuation trials, the results would not have been nearly as applicable to "real world" applications, nor would the research subjects have gained such a valid perspective of the safety role that flight attendants are called on daily to fill.

We also thank the fine paramedics from EMSA, who helped us those few times when things went awry. Thank you all for a project well done.

ACCESS-TO-EGRESS I: INTERACTIVE EFFECTS OF FACTORS THAT CONTROL THE EMERGENCY EVACUATION OF NAÏVE PASSENGERS THROUGH THE TRANSPORT AIRPLANE TYPE-III OVERWING EXIT

INTRODUCTION

Over the last 15 years, a research program of international scope has been dedicated to examining emergency evacuations through the transport airplane Type-III overwing emergency exit. Two laboratories, one in the Aviation Psychology Department of Cranfield University in the United Kingdom and the other at the Federal Aviation Administration (FAA) Civil Aerospace Medical Institute (CAMI) in Oklahoma City, OK, have conducted the research. The genesis of this activity was the 1985 crash of the British Airtours Boeing 737 airplane at Manchester, England, in which a number of passengers died in an apparent attempt to approach and egress through the Type-III overwing exit (AAIB Report 8/88). Further impetus was provided by another accident involving a B-737 and a Fairchild Metroliner at Los Angeles International airport in 1991 (NTSB/AAR-91/08), in which more deaths were associated with attempts to use the Type-III exit. Analysis of these accidents suggested that restrictive cabin interior configurations adjacent to the Type-III exits may have limited access to those emergency egress portals, thereby preventing timely evacuation of the airplanes. The resultant research program was instated to address this issue, studying a range of passageway configurations from the center aisle of a narrow-body transport category airplane to the Type-III overwing exit, accompanied by a variety of interactive evacuation conditions, to assess the importance of cabin configuration adjacent to the exit. A recent report, *Access-To-Egress: A Meta-Analysis of the Factors That Control Emergency Evacuations Through the Transport Airplane Type-III Overwing Exit* (McLean, 2001), forms a capstone for those efforts, systematizing the major findings of the research program through the year 2000. That report should be consulted for a detailed understanding of the relevant issues.

A significant debate has arisen in recent years concerning the research program findings, especially with regard to the ability of different cabin interior configurations to provide acceptable evacuation capability through the Type-III exit, i.e., proper access to egress. The debate exists in spite of the many studies, involving passageway configurations from 3" to 34"

wide and employing a range of distances of aft seat encroachment into the projected exit opening, in which the results have been quite consistent. These results have been obtained with a variety of ancillary evacuation conditions, such as cooperative and competitive egress, clear-air and smoke-filled cabin interiors, different hatch disposal locations, and presence or absence of cabin crew. The combined results have established that intermediate passageway configurations, i.e., those 13" to 25" wide, having aft seat encroachments no farther forward than the exit centerline, provide for essentially equivalent evacuation performance (see McLean, 2001). In fact, passageways no wider than 10" have been shown to be comparable in several of those investigations. However, for some who have appraised the findings, this breadth of equivalence is counterintuitive and gives reason to question the entire enterprise.

The research studies were conducted to assist in the certification of transport category airplanes equipped with Type-III overwing exits; however, the intensity of the discussion surrounding the research program findings has sidetracked this application. The principal issue has been the fact that regulatory use of the research program findings would permit a range of cabin interior configurations, as opposed to some *optimum* arrangement having a wider passageway and lesser aft seat encroachment — a circumstance patently more valid to some. Current efforts toward harmonization of emergency exit access regulations by the FAA and the European Joint Aviation Authority (JAA), as well as renewed interest in the Type-III exit access-to-egress issue by the National Transportation Safety Board (NTSB/SS-00/01), have presented another occasion to resolve the issue.

The report presented here marks the resultant effort to gauge again the effects of cabin interior configuration on access to the Type-III overwing exit, potentially providing a final culmination of the access-to-egress research program. Many of the criticisms that have delayed the formalization of program findings in regulatory language have been acknowledged in the development of the research design, as well as its execution, and much care has been taken to establish an evacuation research project unequivocally worthy of regulatory application.

This attention to detail has been no greater than in past studies; however, with every decision to effect a particular method or produce a particular experimental contingency, attempts have been made to address points of contention relative to earlier investigations. For example, pure subject naïveté with regard to emergency evacuations, as would be found among the general flying public, has replaced the use of repeated-measures designs or *practice* protocols designed to control human performance variability (e.g., McLean & George, 1995). Similarly, a more complex research design, using motivational inducements and larger subject complements in consideration of subject naïveté, has been employed to achieve greater realism and generalizability. Additional subjects, confirmed to be naïve with respect to exit operation and instructed only via graphics taken from current airline safety briefing cards, were made specifically responsible for opening the Type-III exit and disposing of the hatch, as would be expected in typical emergency operations. Again, realism was the defining construct.

The result is the largest, most complex, most logistically difficult, and most interactive investigation in the history of research into the effects on emergency evacuation of hatch operation and cabin interior configuration adjacent to the Type-III overwing exit.

METHODS

Research Design. Although passageway configuration was the main independent variable of interest, the study employed a 4-way (Passageway Configuration x Hatch Disposal Location x Subject Group Motivation Level x Subject Group Density) factorial design. Motivation level was nested within subject group density, which was distributed uniformly across passageway configuration nested within hatch disposal location (see Table 1). Subjects were screened out for prior participation in evacuation research, since the intent was to determine the typical effects of the treatments on *naïve* airline passengers. It was discovered after the fact that (only) one of the 2,544 subjects had been in an actual emergency airplane evacuation.

In addition to passageway configuration, the other independent variables in the design were selected for their known effects on egress performance, as well as their potential for interactions with passageway configuration, that could address the issue of access to egress. As such, hatch disposal location was chosen as an additional airplane-related independent variable, because of the potential for the hatch to negatively influence access space at the exit and interfere with

Table 1
Research Design with Total Group Evacuation Times*

<i>Hatch Location:</i>		Inside				Outside			
<i>Passageway:</i>		6"	10"	13"	20"	6"	10"	13"	20"
<i>Density</i>	<i>Motive</i>								
Low (30)	Low	49.30	51.30	55.97	53.97	60.00	71.13	51.23	50.47
	High	52.97	57.23	59.30	45.17	56.23	47.90	49.30	50.67
Medium (50)	Low	91.40	91.87	90.40	94.20	86.17	89.33	95.97	76.40
	High	87.77	82.77	87.67	83.20	86.77	94.03	80.17	80.77
High (70)	Low	128.97	121.43	144.40	117.03	122.27	133.13	124.47	108.37
	High	107.73	117.07	160.80	111.03	115.33	118.83	108.67	112.50

* Each cell contains the group evacuation time in seconds.

subject egress. Subject motivation level was included because of the demonstrated ability of financial incentives to produce extreme subject behaviors and interact with other independent variables that also altered egress substantially (e.g., Muir, Bottomley, & Hall, 1992). Subject group density was incorporated because of research that had shown nonlinear increases in evacuation time, as the number of subjects per group was increased (McLean, Corbett, and George, 1999), and the potential for that to provide additional discriminatory power with regard to regulatory application of the research findings.

Each subject group completed four evacuation trials, although only the first experimental trial for each group is included here in the results related to individual evacuation time. This between-groups approach to the data provides only a single data point for each subject (group) and is intended to preserve the complete essence of subject naiveté. Additional within-subjects analyses will be conducted and described in a subsequent report of the cumulative effects of individual subject experience and motivation on hatch operation and evacuation time.

Apparatus. The aircraft simulator was configured with six-abreast seating (e.g., B-737) and equipped with a single Type-III overwing exit located on the right side of the airplane cabin 40% of the total distance aft of the front door. The exit opening was 20" wide and 38" high, with a step-up distance of 18" inside the simulator and a step-down of 27" from the centerline of the exit to a sloped *winglet* outside the simulator. The weight of the hatch was set at 45 pounds for all trials.

Passageway Configuration. Four different passageway configurations leading from the main aisle to the exit were used in the study; three of these included single passageways between triple seat assemblies, while the fourth employed 2 passageways, one fore and one aft of a seat assembly in which the outboard seat had been removed. The single passageways employed 3 different passageway widths with 3 different aft seat encroachment distances; the dual passageway configuration with the outboard seat removed was established such that the seat assembly was placed directly adjacent to the Type-III exit. Figures 1 through 4 depict the passageway configurations employed. The tray tables in the passageway seat

Figure 1
20" Passageway With 5" Encroachment

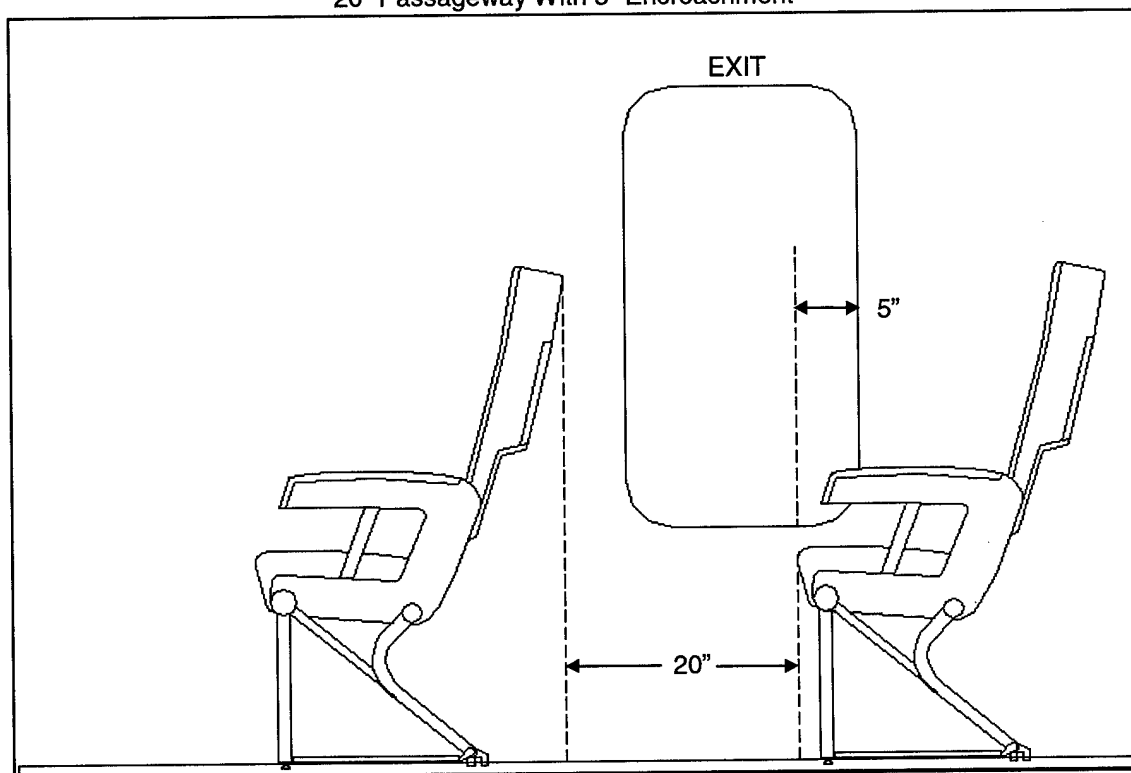

Figure 2
13" Passageway With 10" Encroachment

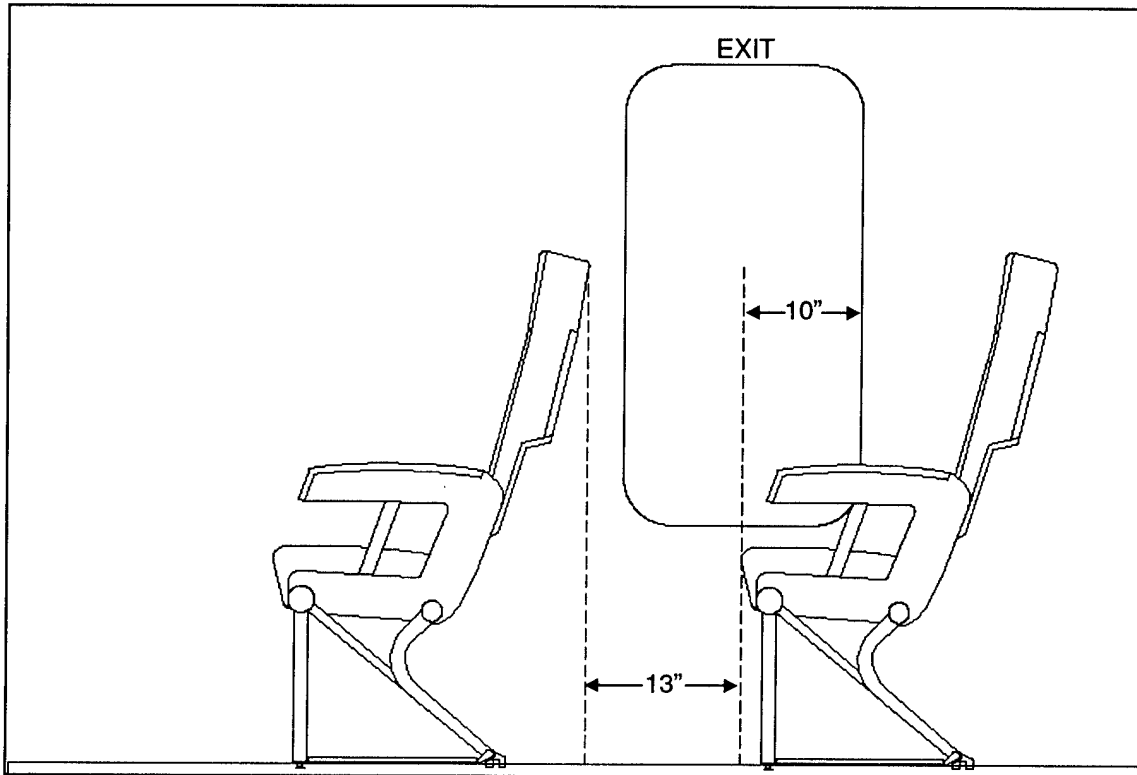

Figure 3
10" Passageway With 14" Encroachment

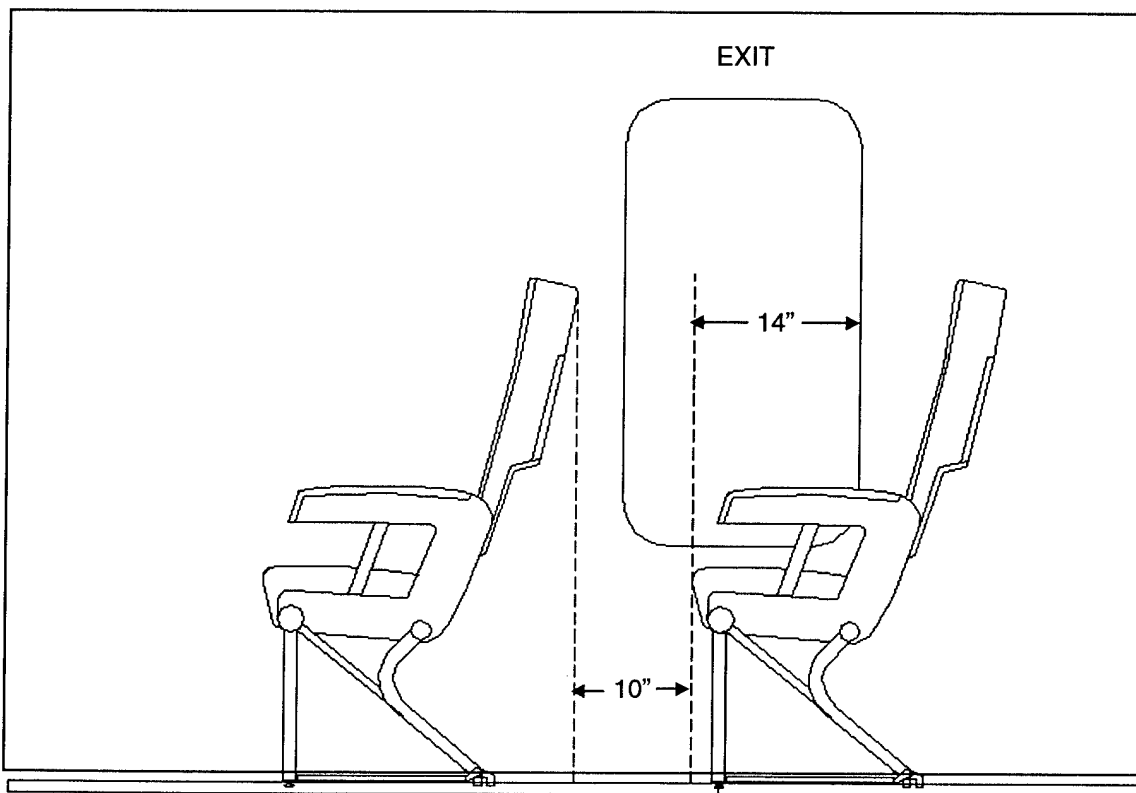
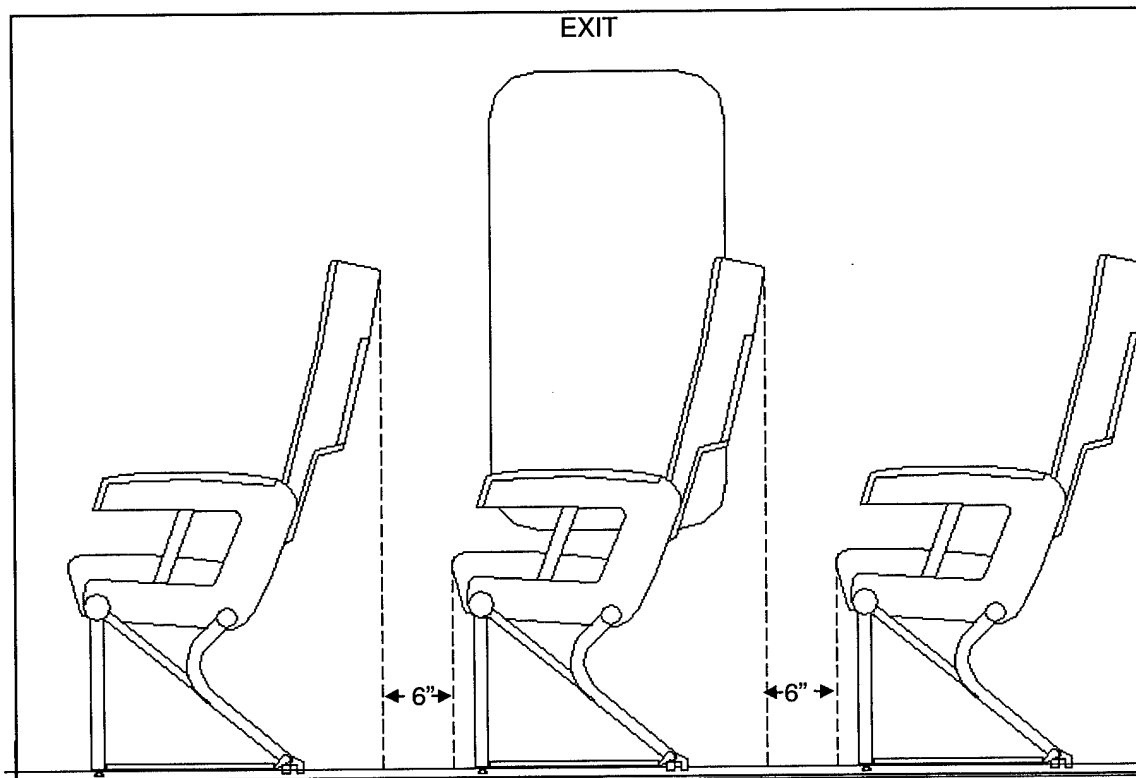

Figure 4
Dual 6" Passageways With Outboard Seat Removed



assemblies were stowed in the rigid arm rests, and all seat backs throughout the cabin were locked to prevent breakover. Remaining seat pitch was set at 31 inches.

Hatch Disposal Location. At the start of each evacuation trial, the Type-III exit hatch was to be removed by the hatch operator from its typical location in the side of the fuselage and placed either inside or outside the simulator, depending on the specific experimental condition. *Inside* hatch disposal was achieved by having the hatch operator place the hatch on the seat where s/he had been sitting (e.g., Figure 5). *Outside* hatch disposal was achieved by having the hatch operator throw it through the exit opening onto the winglet (e.g., Figure 6), where a research confederate would pull it out of the way to prevent subject injury during the ensuing evacuation. In both cases the hatch operator would then climb through the exit, either leading the evacuation or not, depending on whether another subject had squeezed through first.

Subjects were selected to be hatch operators by random assignment as they entered the laboratory and were sequestered away from the rest of their evacuation group after having completed initial paperwork. At that point they were visually briefed regarding

hatch operation via graphics taken from a typical airline safety briefing card. (Figure 7 contains the briefing cards used for both hatch disposal locations.) Any questions they raised regarding specific aspects of hatch operation and/or disposal location were answered by referring them back to the briefing card for further study. No verbal instruction was given to them about the procedure or the evacuation trial for which they would be opening the exit, except to note that a buzzer would be used to start the evacuation. The hatch operators continued to be held inside the laboratory, away from the simulator during evacuation trials prior to their participation, to prevent them from gaining insight about hatch operation and aircraft evacuation. Immediately before the evacuation trial in which each hatch operator participated, s/he was escorted to the simulator and seated adjacent to the Type-III exit. After each of the first three trials, the hatch operator was relocated to another area to preclude the possibility of information sharing with subsequent hatch operators.

Participants. Subjects were apportioned among 48 experimental groups, one-third of which contained either 30, 50, or 70 subjects, for a total of 2,400

Figure 5
Typical Inside Hatch Disposal Location



Figure 6
Typical Outside Hatch Disposal Location



Figure 7
Hatch Operator Briefing Cards

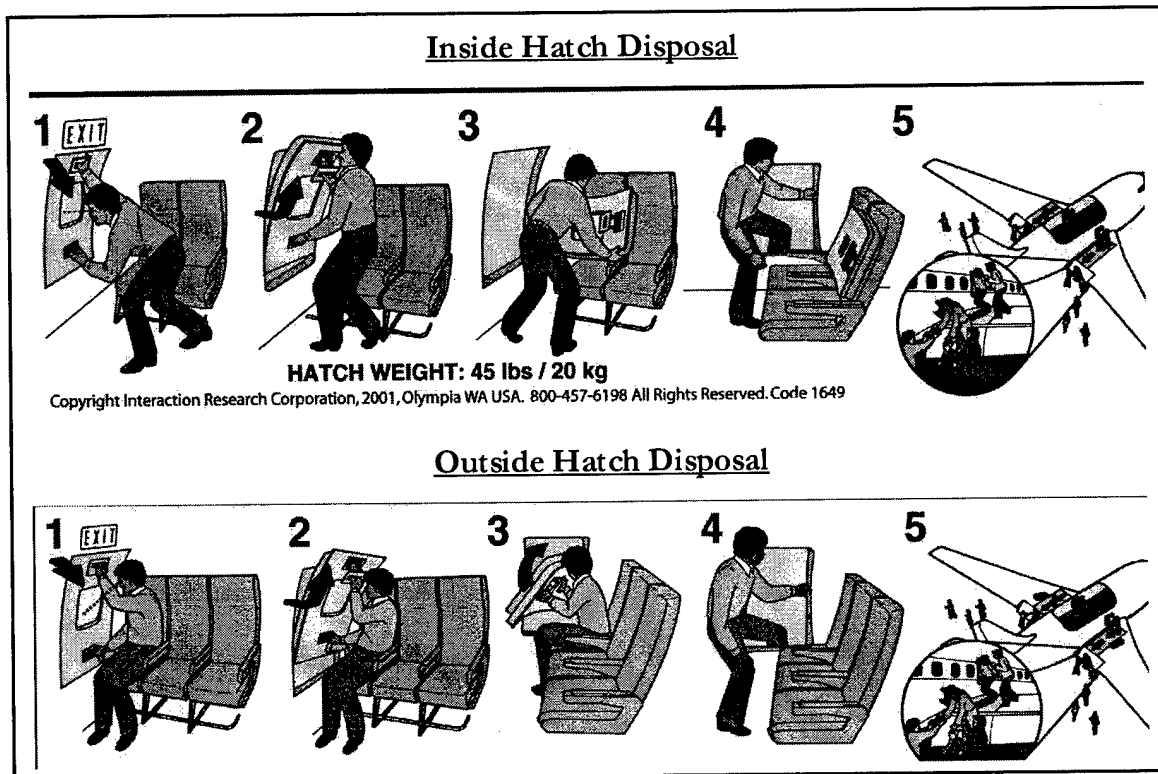

evacuees. An additional 144 subjects were added to the subject pool as *hatch operators*, since 192 (one naïve hatch operator per evacuation trial) were needed for opening the Type-III exit and disposing of the hatch. This resulted in a total of 2,544 human subjects being employed in the study. The pool of subjects, comprised of 51% males and 49% females, ranged in age from 18 to 65 years of age, in weight from 95 to 416 pounds, and in height from 54 to 81 inches.

The research staff included 31 FAA employees, 15 contractor personnel, and a contingent of professional flight attendants. The contract employees were responsible for subject delivery and administrative processing functions, as well as maintenance of the research facility; FAA personnel were devoted to subject processing, medical management, and execution of the experimental trials. Two flight attendants were employed on each trial for *passenger* management during the evacuations.

Motivation. The low motivation condition, often termed *cooperative egress*, was established by a briefing given in the simulator by the principal investigator prior to each trial. In the briefing, subjects were told that the airplane had *crashed* and was *on fire*, and that to stay alive they had to hurry to get out.

The higher motivation condition, *competitive egress*, was induced by offering double pay to subjects in half of the groups; individual success would be achieved by those who were among the first 25% of their group to evacuate the aircraft simulator, averaged across all 4 evacuation trials. This offer was made in addition to providing them with instructions identical to those given to the low motivation subjects. The technique of averaging across trials was intended to assure sustained competition among all subjects in any individual trial; seat assignment was rotated on trials to give all subjects equal opportunity to earn the bonus.

Flight Attendant Participation. Two flight attendants, one in the front of the cabin and one in the rear, were seated in jumpseats at the start of each trial. At the sound of the start buzzer, the forward flight attendant pointed at the exit and commanded the hatch operator to "Open That Hatch." Both flight attendants immediately started commanding "Unbuckle Your Seatbelts... "Evacuate... Get Out... Get Out... Hurry," as they started herding the subjects toward the Type-III exit. The flight attendants continued to command the evacuation throughout the entire trial, but were not allowed to physically assist

subjects in any way. Their purpose was to keep subjects *on task* as would be expected in an actual emergency evacuation.

Procedure. Prospective subjects were in-processed and informed about the requirements of the study, after which they executed informed consent. Subjects then completed a personal demographics questionnaire, the Transport Canada Personality Profile^a (TCPP, 2000), and a questionnaire that gauged their attention to, and knowledge about, actual preflight safety briefings on airliners. Their physical attributes were then measured, and they were photographed for identification purposes. Afterward, they were escorted to the simulator to become visually familiar with the exterior layout; they were issued a boarding card with their first seat assignment; they entered the simulator; and they seated themselves accordingly. Upon completion of the safety briefing for the trial, subjects were allowed to ask questions.

Following any questions, and after subjects confirmed their readiness to proceed, the principal investigator read the *preflight* briefing and exited the cabin, leaving only the flight attendants with the subjects. The start buzzer was sounded after a variable interval of 5 to 30 seconds, whereupon the flight attendants began shouting and gesturing for the subjects to unbuckle their seatbelts and proceed through the exit. The hatch operator, seated next to the exit, removed

the hatch and disposed of it, allowing the evacuation flow to begin. Research personnel stationed outside the simulator recorded subject vest numbers for subsequent analysis of bonus payments. After the trial was completed, subjects were regrouped for the next trial.

Data Archival, Reduction, and Analysis. Eight video cameras, 4 inside the simulator and 4 outside, recorded all experimental trials (see Figure 8). The videotapes were recorded at the National Television System Committee (NTSC) standard of 30 frames per second and superimposed with an electronic time code providing a temporal resolution of 33.3 milliseconds. Videotapes of each trial were examined manually to obtain group and individual evacuation times; these times were combined in a database with the individual subject characteristics. The data were analyzed using the multiple regression, analysis-of-variance, and analysis-of-covariance routines in SPSS[®] 10.0 (1999).

Total group evacuation time for each trial was defined as beginning at the time the start buzzer initially sounded and lasting until the last subject had cleared the Type-III exit opening (see cells in Table 1). Because of the differences in the number of subjects within the groups, however, no predictive analyses were conducted on these group times. Instead, the times were divided into hatch removal and disposal times, as well as the times for individual subjects to

Figure 8
Data Acquisition and Archival

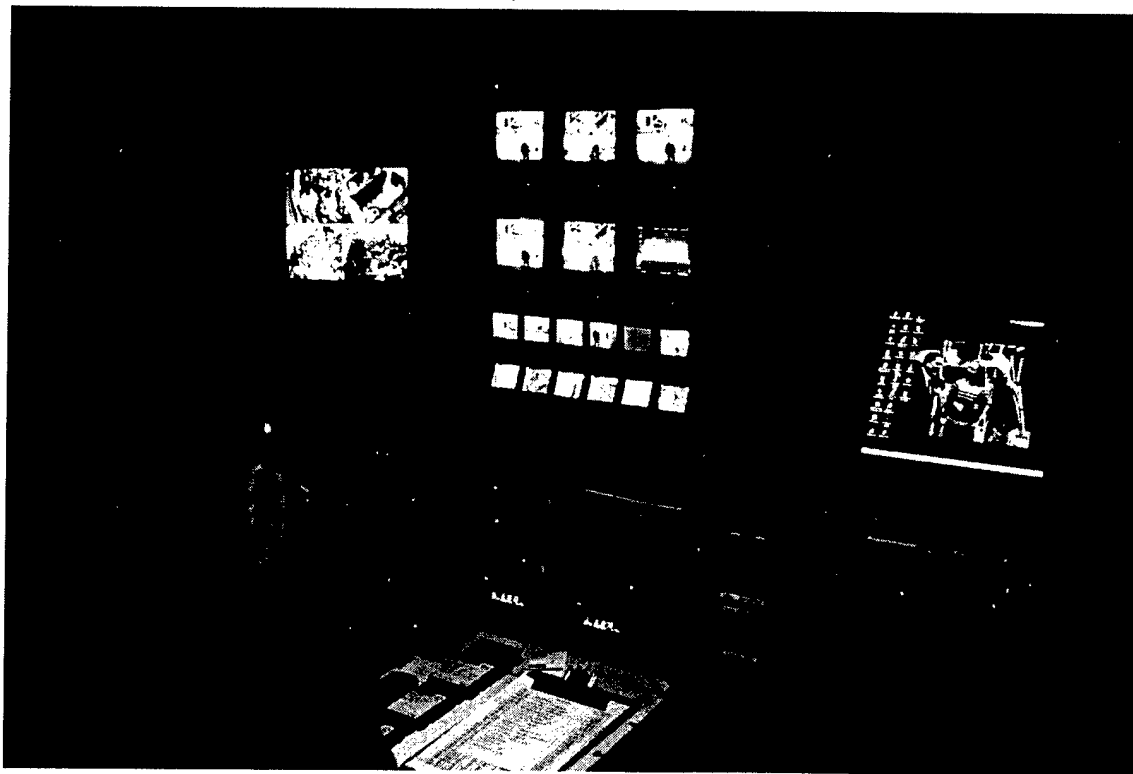

egress, to allow for between-subject analyses of the effects of the independent variables and their interactions. Individual subject egress time was defined as the period lasting from the time (videotape frame) at which one subject was completely through the exit opening until the time the next subject was completely through the opening. The effects on hatch operation and individual subject egress have been organized within subcategories for reporting purposes, so as not to lose continuity of thought for each type of effect.

RESULTS

Note that, in the figures presented below, solid lines are used to connect interval data points within any category, whereas dotted lines are used to connect data points for discrete classes of a variable. For example, dual 6" passageway data points are connected to the single 10" passageway data points via a dotted line, while the 10", 13", and 20" passageway data points are connected via solid lines. This particular distinction was made to highlight the fact that it was the additional passageway available for egress with the most restrictive (6") passageway configuration that afforded individual egress times generally comparable to those produced by the more ergonomically-generous single passageway configurations.

Hatch Operation. Because there was a naïve subject responsible for operating the hatch on every trial, the effects of the independent variables on the time required to remove and dispose of the hatch were analyzed for all 192 evacuation trials, not just the first trial for each group. The total hatch operation and disposal time was separated into 3 different periods. These included Exit-Ready-To-Use Time, which denotes preparation of the exit for egress, First-Subject-Out Time, which is the time at which the first person had fully cleared the exit opening, and Hatch-Operator-Out Time, the time at which the operator was completely out. Four-way Analysis of Variance (ANOVA) was used to analyze the data for each of these times.

Exit-Ready-To-Use Time began at the initial sound of the start buzzer and lasted until the first person began to emerge from the exit. The ANOVA revealed a significant main effect on Exit-Ready-To-Use Time for hatch location ($p < .005$; Figure 9); there was also a large interaction of hatch location with passageway configuration ($p < .001$; Figure 10). This interaction effect was produced by significantly elevated outside hatch disposal times in the 10" passageway configuration, resulting from the increased ergonomic difficulty produced by excessive forward encroachment of the aft seat assembly. However, the passageway configuration main effect failed to achieve significance ($p < .08$;

Figure 9

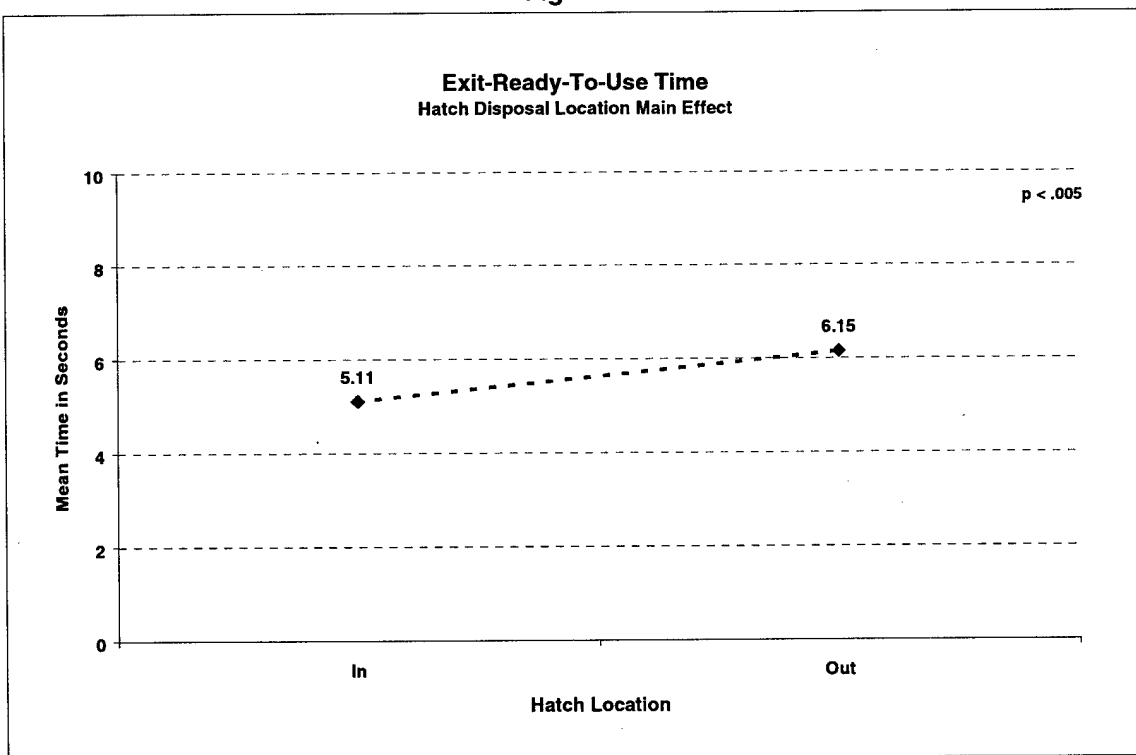

Figure 10

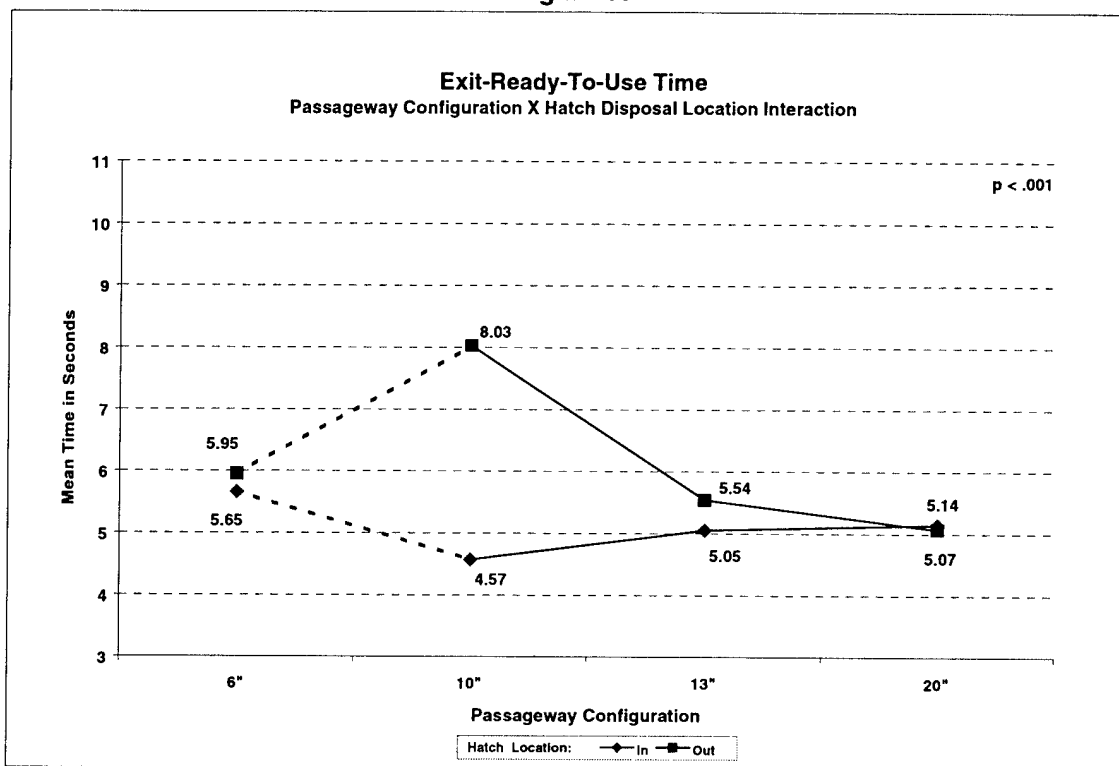

Figure 11), as did the subject group motivation level ($p < .52$) and subject group density ($p < .54$) main effects. None of the individual hatch operator characteristics influenced exit operation significantly, nor did they interact with any of the other variables. Disposing of the hatch inside the cabin led to shorter overall Exit-Ready-To-Use Times.

First-Subject-Out Time was computed to provide a starting point for the individual subject egress time computations. This time began at the end of the Exit-Ready-To-Use Time. Generally, this period was about equal to the sum of Exit-Ready-To-Use Time and the mean individual subject egress time for any particular trial. However, behavioral interactions among subjects and delays in completely disposing of the hatch sometimes lengthened this initial egress period. On six of the trials, the hatch operator was not the first person out of the exit, complicating the computation of this dependent variable. A significant main effect on First-Subject-Out Time was discovered for hatch location ($p < .01$; Figure 12), and there was an interaction of hatch location with passageway configuration ($p < .015$) largely reminiscent of that seen for Exit-Ready-To-Use Time. Again, the interaction effect was dependent on significantly increased times associated with operation of the hatch in only the 10" passageway configuration (see Figure 13). However, the passageway configuration main effect failed to achieve

significance ($p < .10$; Figure 14), as before; main effects for subject group motivation level ($p < .34$) and subject group density ($p < .42$) were similarly insignificant. None of the individual hatch operator characteristics were predictive of First-Subject-Out Time, nor did they interact with any of the independent variables.

These effects were remarkably similar to those seen for Exit-Ready-To-Use Time, and indicate that the time required for removal and disposal of the hatch was the primary variable in launching the evacuation flow. This relationship can be seen easily by comparing Figures 9, 10, and 11 for Exit-Ready-To-Use Time with Figures 12, 13, and 14 for First-Subject-Out Time. The lack of significance regarding differences in motivation level was somewhat surprising, given the general perception of greatly increased chaos at the start of the high motivation trials, especially when the designated hatch disposal location was inside the cabin.

Hatch-Operator-Out Time was derived to measure the effects of differential hatch operation on the ability of the hatch operator to egress. A related question was focused on the effects of subject motivation level on the efficiency of hatch operation. This time period began at the sounding of the start buzzer and ended when the hatch operator had cleared the exit. The expectation had been that the hatch operator would be the first person out of the exit, which led to

Figure 11

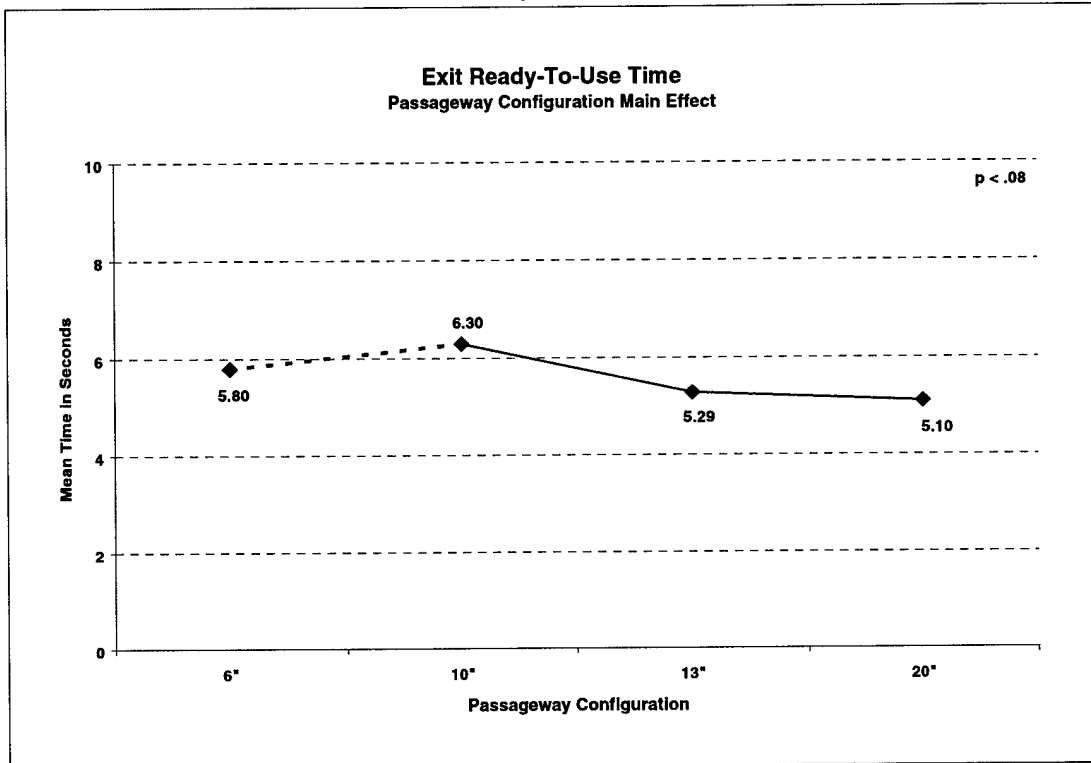

Figure 12

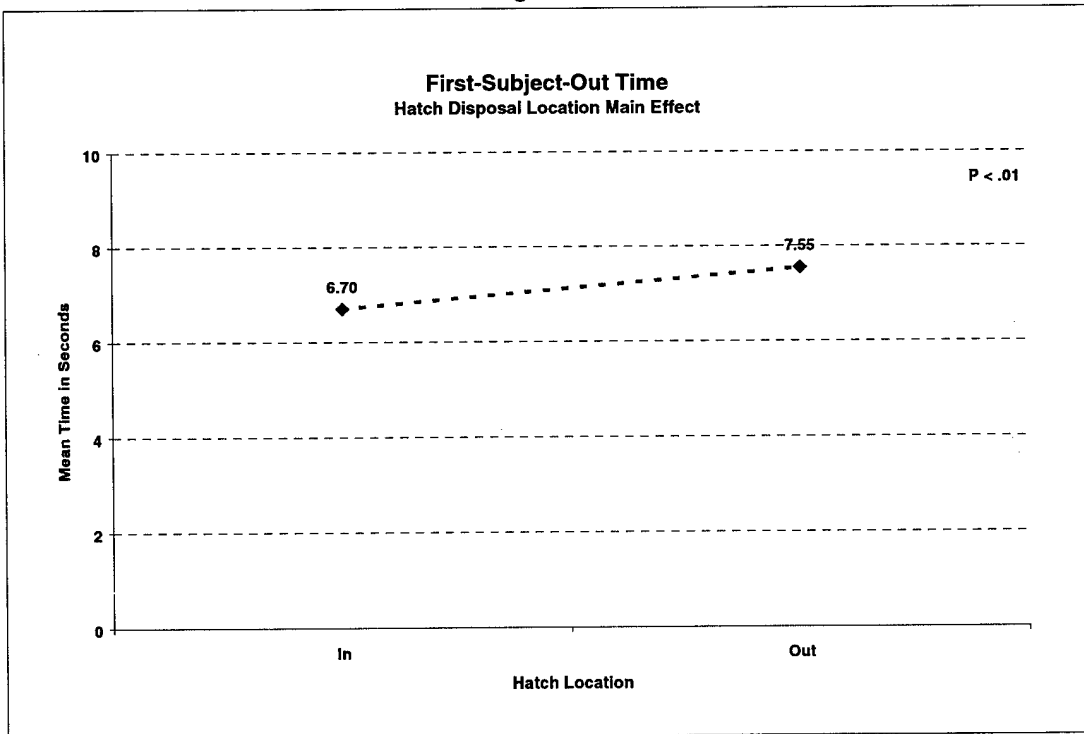

Figure 13

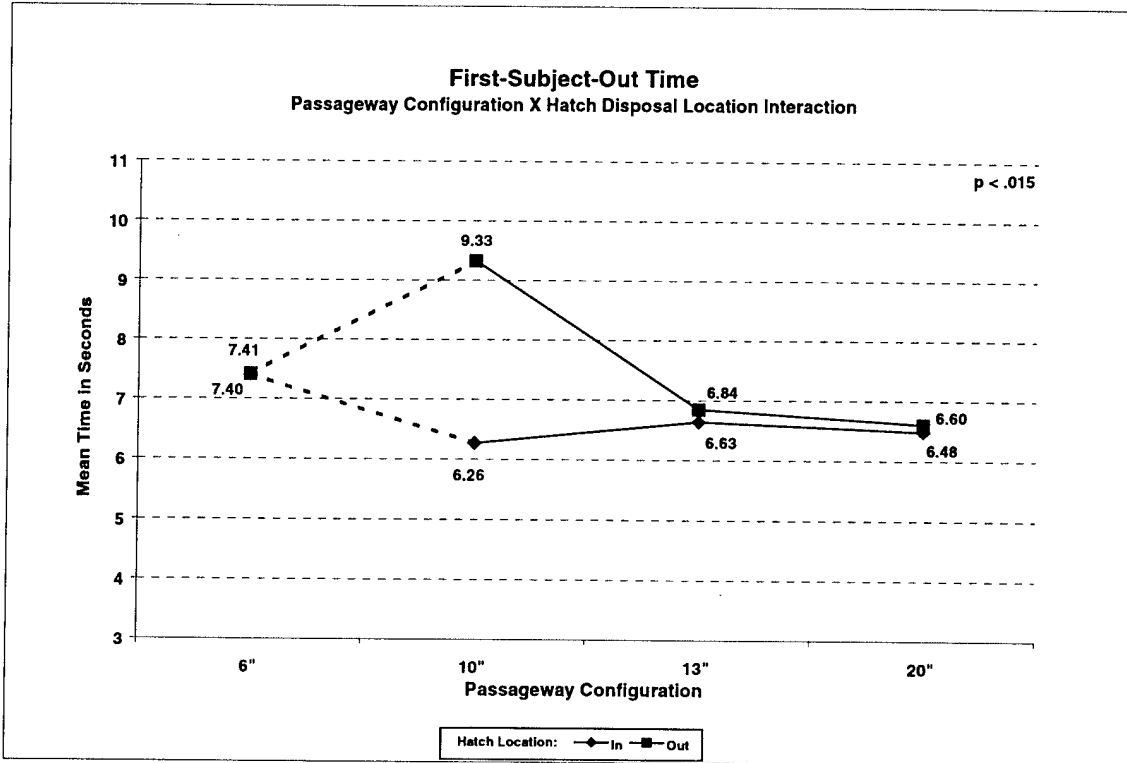

Figure 14

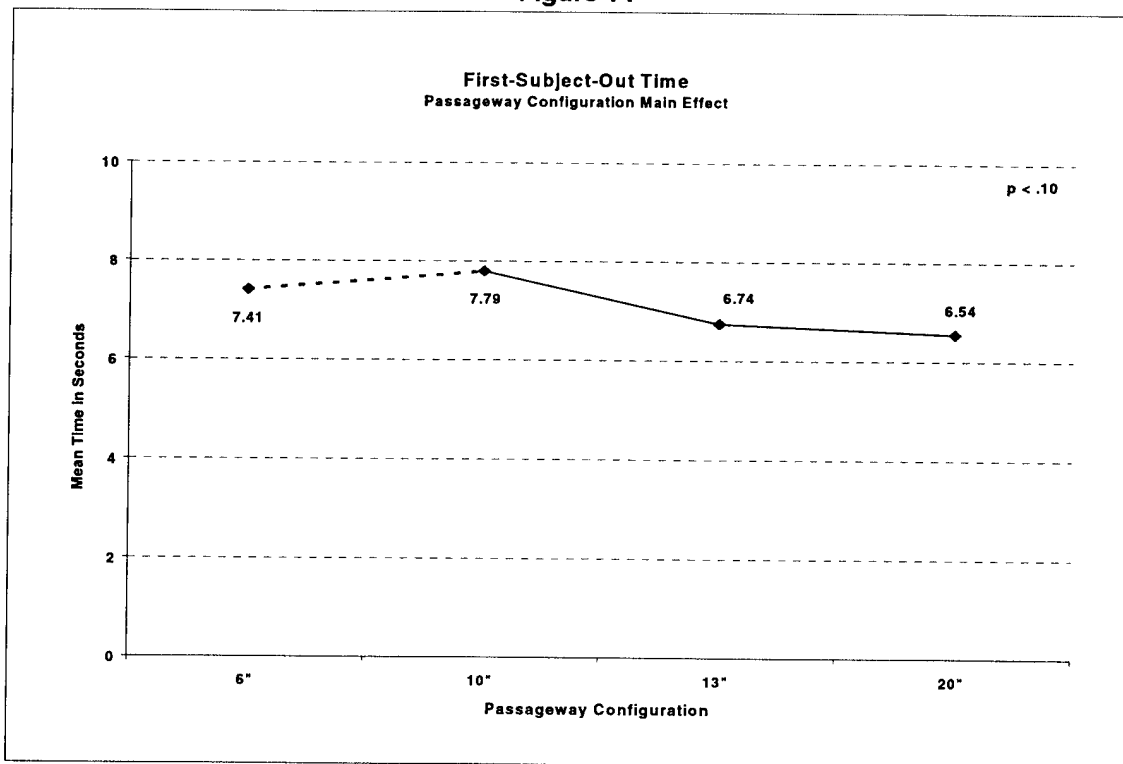
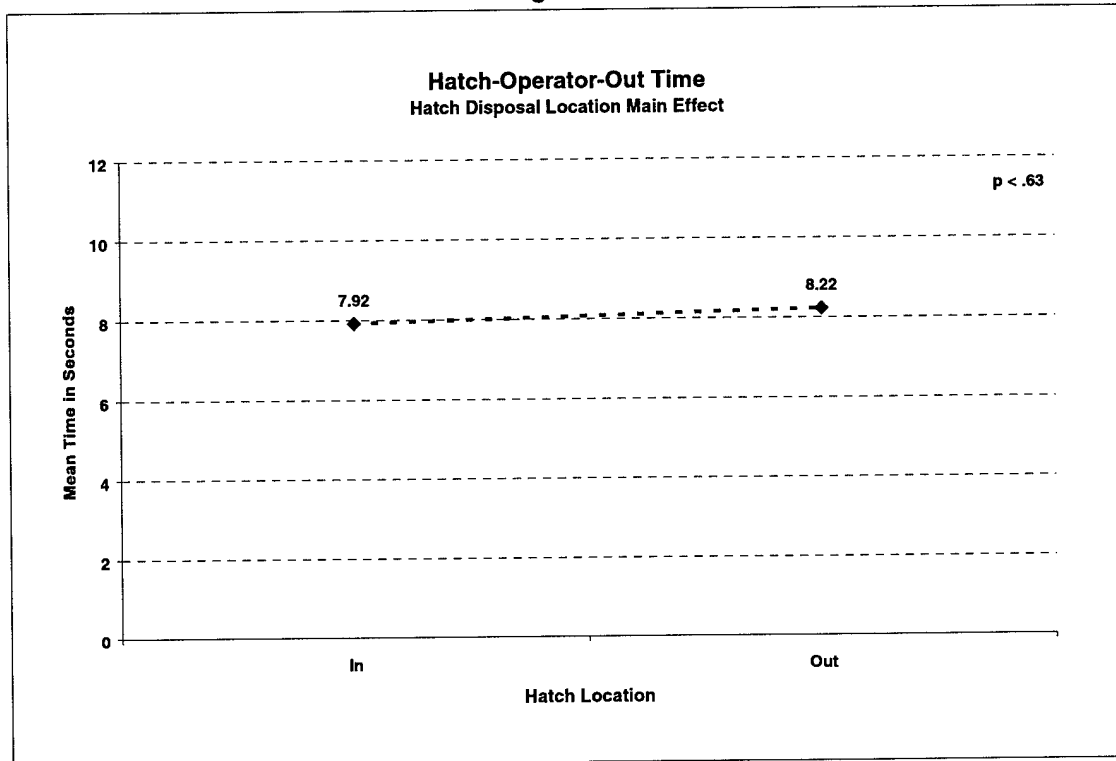

Figure 15



the expectation that the Hatch-Operator-Out Times would mirror the First-Subject-Out Times. This, however, proved not always to be the case, since the hatch operator was not always the first person out, principally in the dual passageway configuration.

The significance of the prior hatch location main effects was lost on Hatch-Operator-Out Time ($p < .63$; Figure 15), as was the significance of the hatch location by passageway configuration interaction effect ($p < .20$; Figure 16), which was somewhat similar to that for the First-Subject-Out Time. In contrast, passageway configuration was found to exert a significant main effect on Hatch-Operator-Out Time ($p < .012$; Figure 17), resulting from a monotonic increase in the time the hatch operator needed to egress as the single passageway configurations became more restrictive ergonomically. This time increased even more in the dual passageway configuration, both because of the increased distance between the exit and the seat where the hatch operator had been sitting, and where the hatch was to be placed, as well as competition for use of the exit produced by subjects using the aft passageway. However, there was no main effect for subject group motivation level ($p < .86$) or interaction of motivation level with passageway configuration ($p < .53$), again in the face of perceptible chaos. There were also no main effects or interactions of subject group density ($p < .94$) with any of the individual

hatch operator characteristics. Thus, the delays in hatch operator egress created by the more restrictive passageway configurations and competition for the exit produced minimal effects on the start of the evacuations and on total group evacuation time.

Hatch Operation Discussion. The ability of the hatch operators to prepare the Type-III exit for egress was remarkably good, although the techniques they used for removing the hatch were often inefficient. Many times the hatch operators would use the wrong hand to grasp the handle, which caused them to labor with the weight and bulk of the hatch, and often they would turn counter-clockwise to place the hatch on the seat. This rotational direction unnecessarily slowed the start of those evacuation trials, especially when other subjects were pressing against them in a harried attempt to reach the exit. However, they almost unerringly placed the hatch in the designated location. Of the few incorrect hatch disposal locations, all of which happened during trials in the inside hatch disposal condition, the hatch was intentionally stood on the floor against the back of the outboard seat immediately forward of the passageway 3 times in the high-motivation condition (e.g., Figure 18), and it was knocked from the seat onto the floor once more. Three of these events occurred in the dual passageway configuration, while one of the intentional floor placements occurred in the 20" single passageway

Figure 16

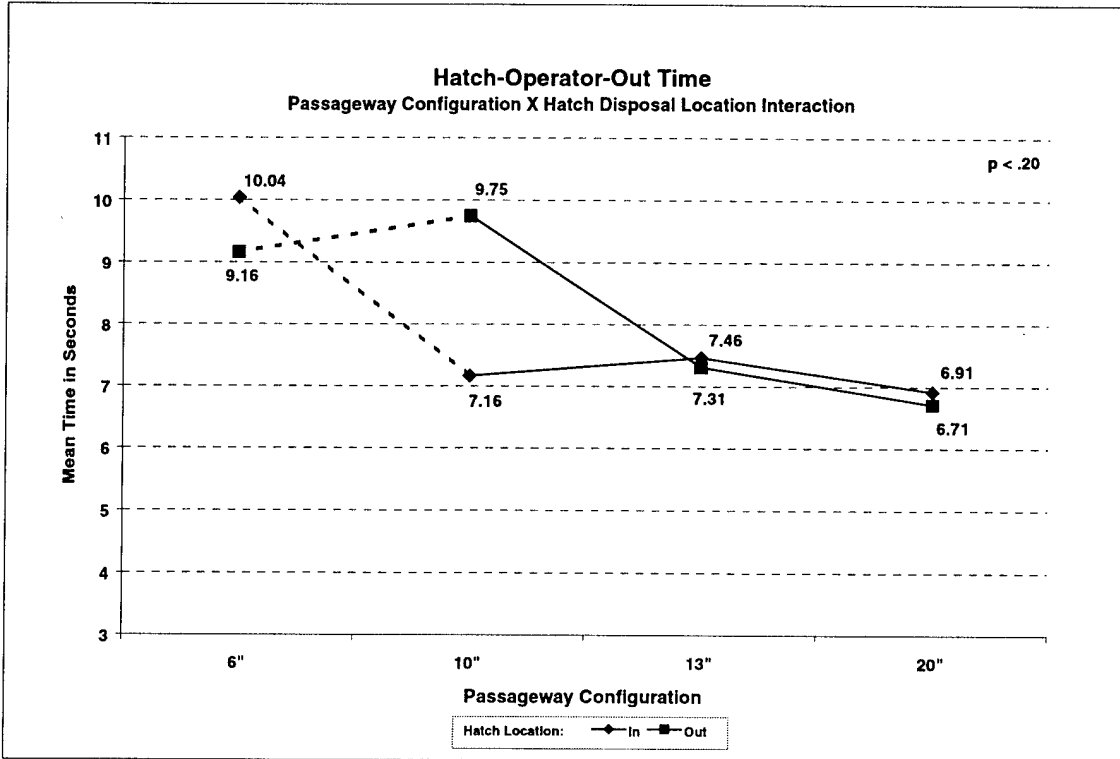

Figure 17

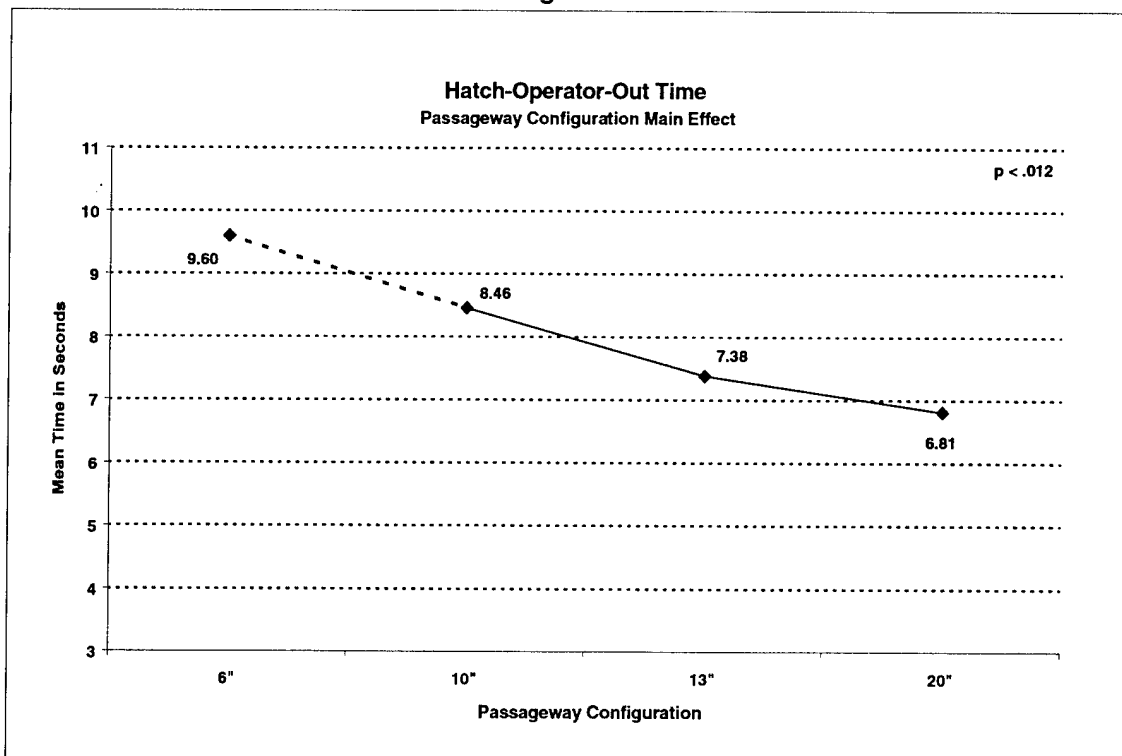
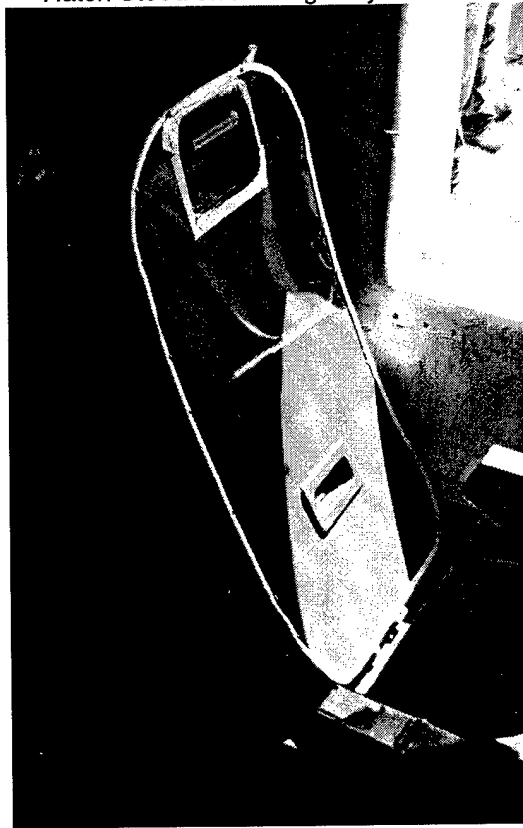

Figure 18
Hatch Stood on Passageway Floor



configuration. Three other times the hatch came to rest on the seat assembly one row behind the passageway, and once it was passed across the main aisle during the evacuation. The only other erroneous hatch disposal location occurred when the hatch was wedged between the exit row seat assembly and the side of the fuselage, which had no discernible effect on the evacuation. The usually compliant nature of hatch operation, vis-à-vis the briefing card, indicates that the hatch operators were fully aware of the intended task and, furthermore, they were quite willing to perform as instructed. This circumstance bodes well with regard to what can be expected of typical airline passengers who are fully informed about their responsibilities when seated adjacent to the Type-III overwing exit.

The effects of the independent variables on hatch operation and the start of subject egress through the Type-III exit were minor. Hatch disposal location produced small effects on exit preparation time and, therefore, the time for the first person to egress. It was generally the case that inside hatch disposal allowed the fastest evacuation start times by about one second, on average, relative to outside disposal. Passageway configuration, on the other hand, had little effect on hatch operation and the start of the evacuations, except where the most ergonomically restrictive pas-

sageway configuration slowed hatch operator egress. The interaction of outside hatch disposal with the single 10" passageway configuration almost doubled evacuation start times; this effect resulted from the difficulty hatch operators experienced in leaning over the seat cushion to remove the hatch and throw it outside. In contrast, placing the hatch inside the cabin in the 10" configuration resulted in the fastest exit preparation times. Combined, these results indicate that, in terms of Type-III exit operation and the effects of hatch disposal location on the start of an evacuation, either hatch disposal location could be justifiably chosen for airline operations, as long as aft seat encroachment is limited to the centerline of the exit.

Once the exit was ready to use, there was little else that delayed the start of the evacuation. While the chaotic appearance of the evacuation trials associated with the high motivation condition created the perception of increased exit preparation times and delayed evacuation start times, there were only small numerical differences in start time between motivation levels. This result was maintained even in the dual passageway configuration. Differences in subject group density failed to influence exit preparation and evacuation start times, generally because exit preparation was completed before distant subjects neared the

exit. Individual hatch operator characteristics were also not predictive of exit preparation, except in a couple of instances where the hatch was too heavy for the assigned operator and was manipulated by another subject. This latter circumstance supports the current practice of requiring passengers sitting adjacent to the Type-III exit to be older than 15 years of age, and further suggests that small female adults should not be seated next to the overwing exit. In sum, the ability of the typical hatch operator to prepare the exit for an evacuation was not particularly dependent on any of the independent variables except hatch disposal location, unless the passageway was offset from the exit opening too far to provide an ergonomically appropriate workspace. In those instances, hatch operator strength and technique were important.

Evacuation. Although there were 48 first-trial total group evacuation times, the complexity of the experimental design and the statistical variability this complexity produced among individual groups precluded analysis of total group evacuation times. In addition, there was a clear lack of comparability between certain groups that made such comparisons immaterial. For example, no meaningful comparison could be made between the total group evacuation times for groups comprised of 30 and 70 subjects, although comparison of the egress time for the first 30 subjects in all groups was possible. Analysis of those first-30-subject egress times revealed no significant differences among the groups. In consideration, the total group evacuation times were deconstructed into individual subject egress times, the first of which began at the First-Person-Out Time and ended when the second subject was completely through the exit. This one-subject-completely-out to next-subject-completely-out algorithm was used until the individual egress times for all subjects in each evacuation trial were derived. This procedure provided a database of 2,352 individual subject egress times by which to calculate the effects of the independent variables (Design Factors), as well as the effects of the individual (Human Subject) characteristics. The large number of observations provided an enormous amount of statistical power, allowing the data to be screened for significant egress time outliers, i.e., those whose times were greater than 3 standard deviations above the mean for each passageway configuration. This resulted in the removal of 41 individual subject egress times, with minimum times of 4.1 seconds with the 20" configuration, 4.9 seconds with the 13" configuration, 4.5 seconds with the 6" configuration, and 4.4 seconds with the 10" configuration. Examination of the videotapes showed that the outlying egress times generally resulted from errant

individual subject behavior, such as improper egress techniques/delays getting through the exit opening, getting a foot or leg caught between seats, and from the exit being jammed with subjects during egress. However, no evacuation trial was halted because of exit blockade. The table in Appendix A provides the details of all outlying individual egress times.

All variables, including both design factors and subject characteristics, were subjected to an initial multiple regression analysis to assess relative significance with regard to individual subject egress time. The results indicated that subject waist size accounted for the greatest amount of variance in the data ($p < .0001$), followed next by gender ($p < .0001$), and then age ($p < .0001$). Neither subject height nor any of the independent variables added further to the regression model. This was the first evidence that the individual subject characteristics were significantly more important to the evacuation outcomes than were the independent variables.

Design Factors Effects. After the regression analysis was completed, a univariate analysis of covariance (ANCOVA) was computed to assess the interactive effects of the independent variables. The covariates included the 3 human subject characteristics found to be significant in the regression model; all 4 of the independent variables were used as the experimental design factors. The ANCOVA failed to find significant main effects of hatch disposal location ($p < .96$) and subject group density ($p < .32$), as the disposal locations and group densities all produced nearly identical mean individual egress times (see Figures 19 and 20). However, a significant hatch disposal location by subject group density interaction effect was identified ($p < .05$; Figure 21) that resulted from a small increase in individual subject egress times as group density increased in the inside hatch disposal condition, relative to egress times that remained essentially flat with increased group density in the outside hatch disposal condition. The main effect of subject group motivation level on egress times also proved not to be significant ($p < .78$; Figure 22). However, the data unexpectedly showed that individual subject egress in the high-motivation condition had been faster, a result in contravention to the numerous reports of slowed evacuations for high-motivation subjects in studies employing financial incentives to create the high-motivation condition (for review see McLean, 2001).

Passageway configuration was shown to produce significant main effects on individual subject egress times ($p < .001$; Figure 23), resulting from small (0.16 second) differences in mean individual egress times

Figure 19

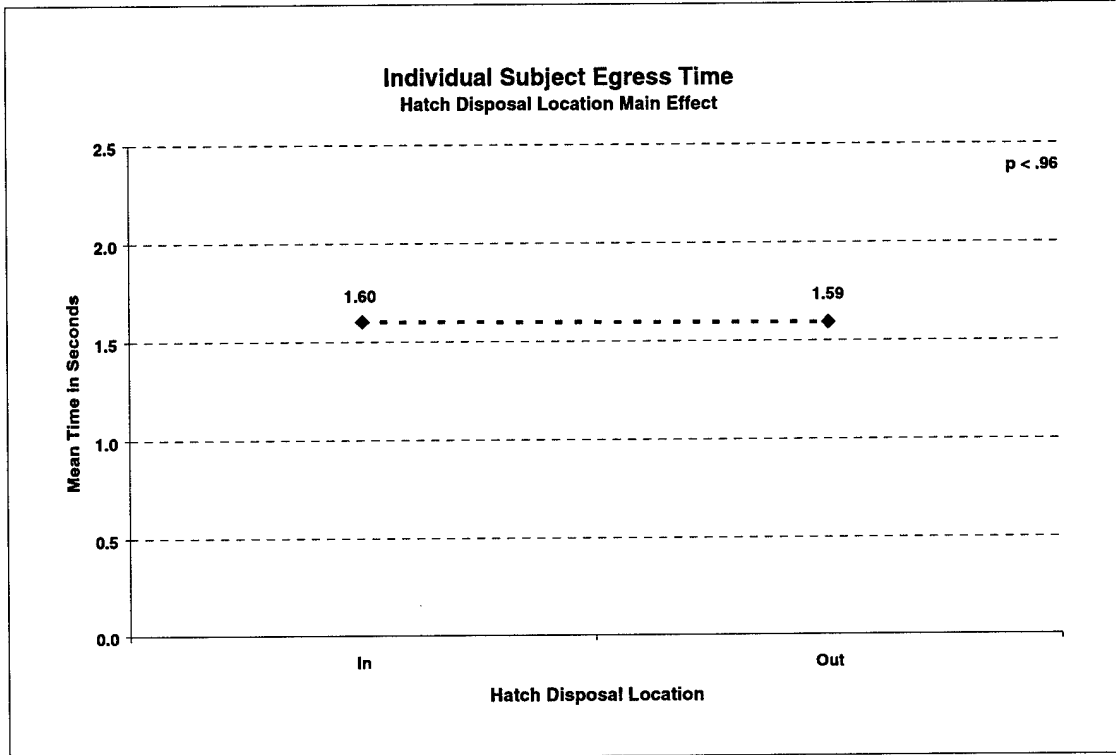

Figure 20

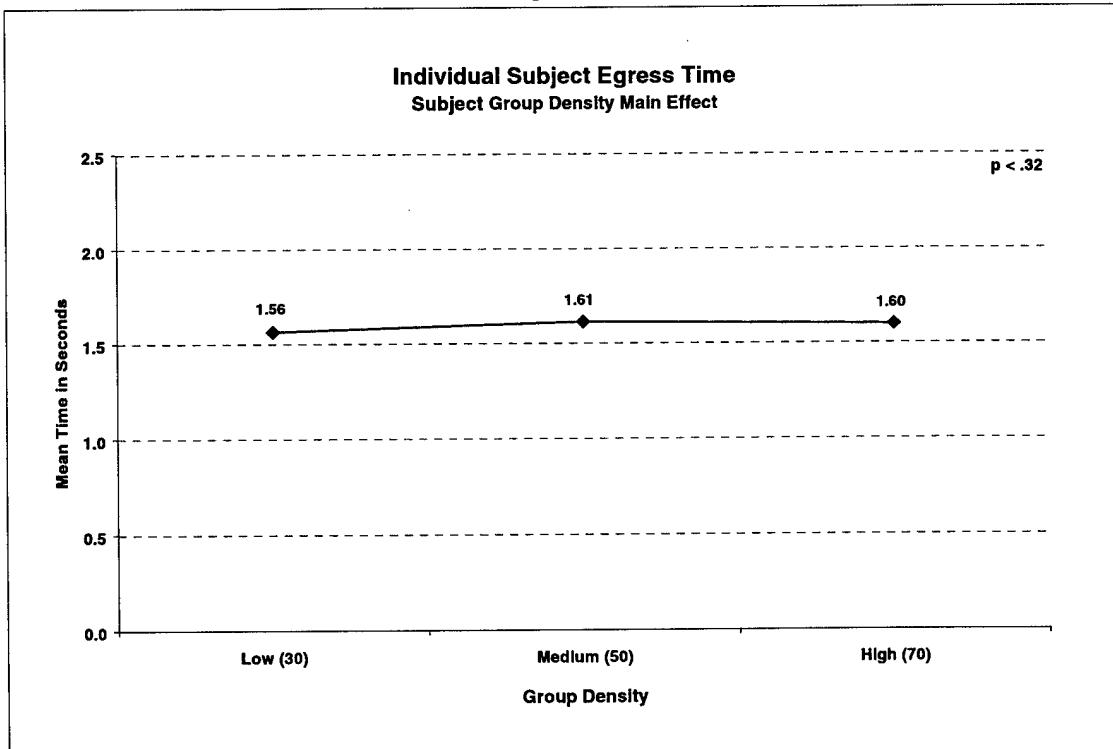

Figure 21

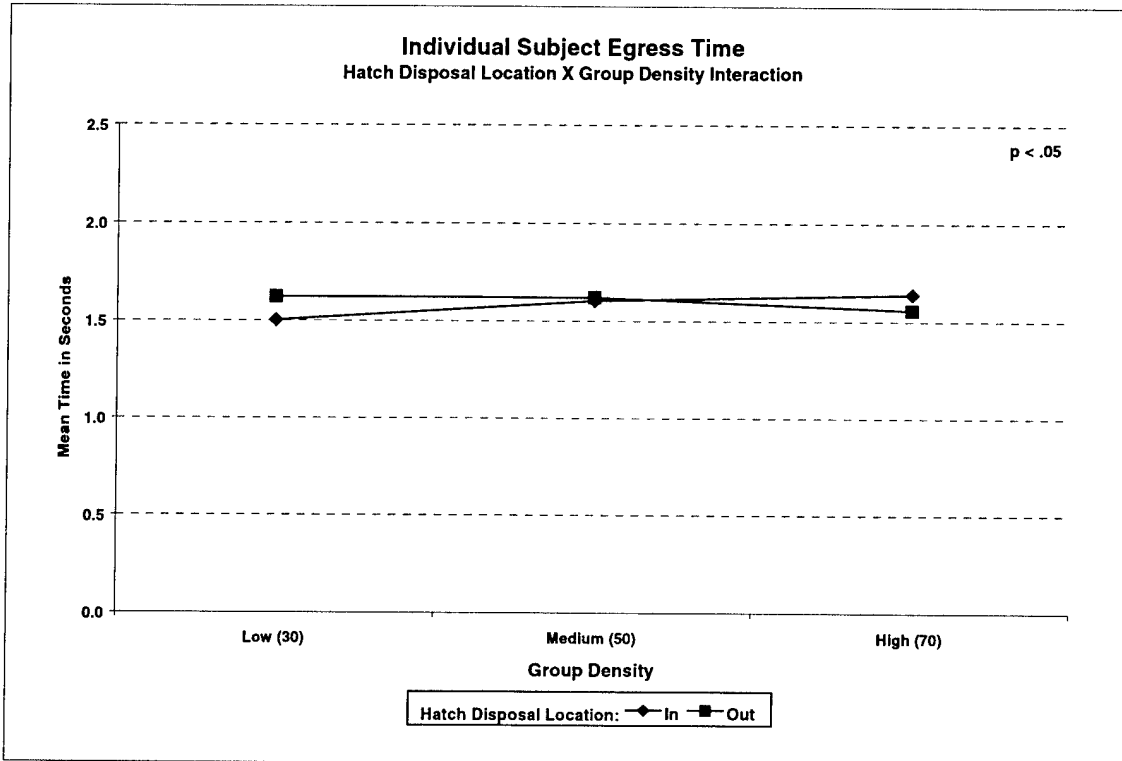
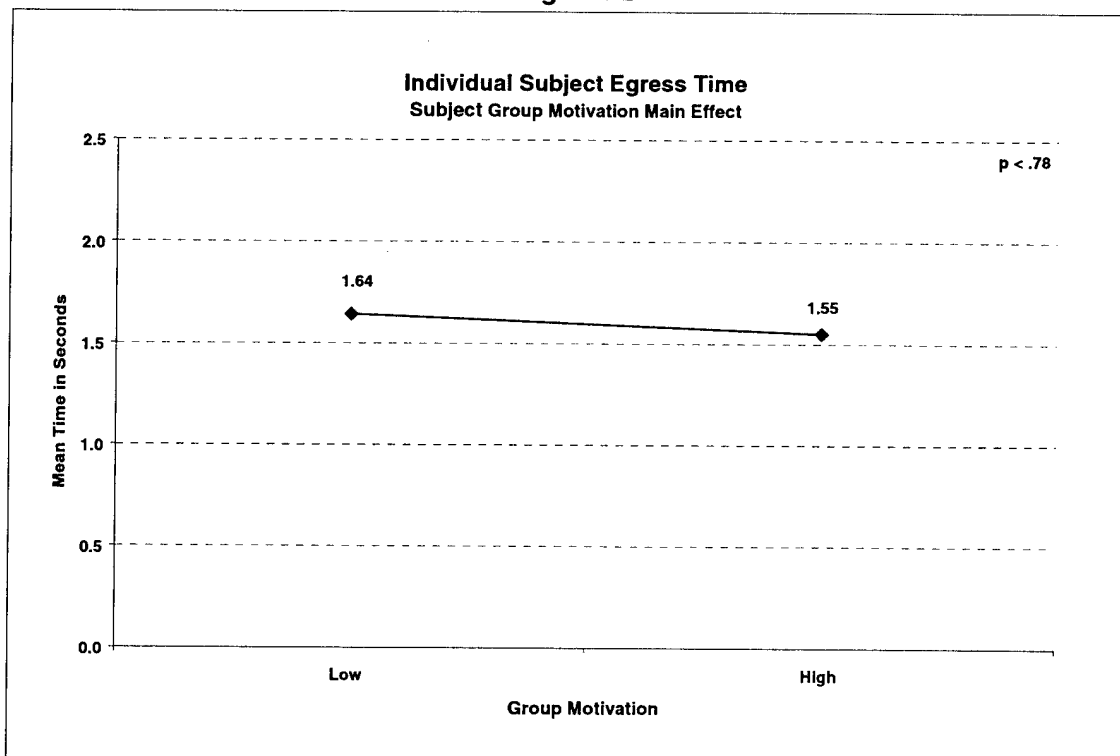

Figure 22



among the passageway configurations. An interaction of passageway configuration with subject group density ($p < .01$; Figure 24) was produced by a relative shuffling of egress times for each density condition within the 10" and 13" passageway configurations. This effect was accompanied by an interaction of passageway configuration with hatch disposal location ($p < .001$; Figure 25), created by elevated egress times with the 13" passageway configuration with inside hatch disposal and the 10" configuration with outside hatch disposal.

The relative character of these times was puzzling, since the most ergonomically restrictive passageway configuration provided faster egress with the hatch placed inside, when compared with the less restrictive configurations in the same hatch disposal condition. The disorderly nature of both interaction effects suggested that much was to be learned from the individual egress times in the 10" and 13" passageway configurations, which led to additional scrutiny of the interactions among these and the other independent variables. The higher-order interactions were particularly instructive.

While the passageway configuration by group motivation interaction effect failed to achieve significance ($p < .27$; Figure 26), a significant (3-way) passageway configuration by group density by group

motivation level interaction effect ($p < .015$) was evidenced, as was a significant (4-way) passageway configuration by hatch disposal location by subject group density by subject group motivation level interaction effect ($p < .008$). The basis of this 4-way interaction effect can be seen in Figures 27 and 28, which show that (1) the individual subject egress times in the 13" passageway configuration with inside hatch disposal were greater for the high-density subject groups, especially in the high motivation condition, and (2) the individual subject egress times in the 10" passageway configuration with outside hatch disposal were much greater for the low motivation group in the low density condition and the medium density group in the high motivation condition. These results led to a further review of the videotapes of those trials for an explanation. The reasons for the elevated times became clear immediately.

Closely after the start of the high-motivation, high-density trial with the 13" passageway configuration with inside hatch disposal, the hatch was knocked from its upright position, falling flat on the seat and laying across the exit opening (see Figure 29). This produced an obstruction to egress, significantly increasing individual subject egress times. The low motivation trial was beset with a similar problem. In that trial the hatch was also knocked onto the seat

Figure 23

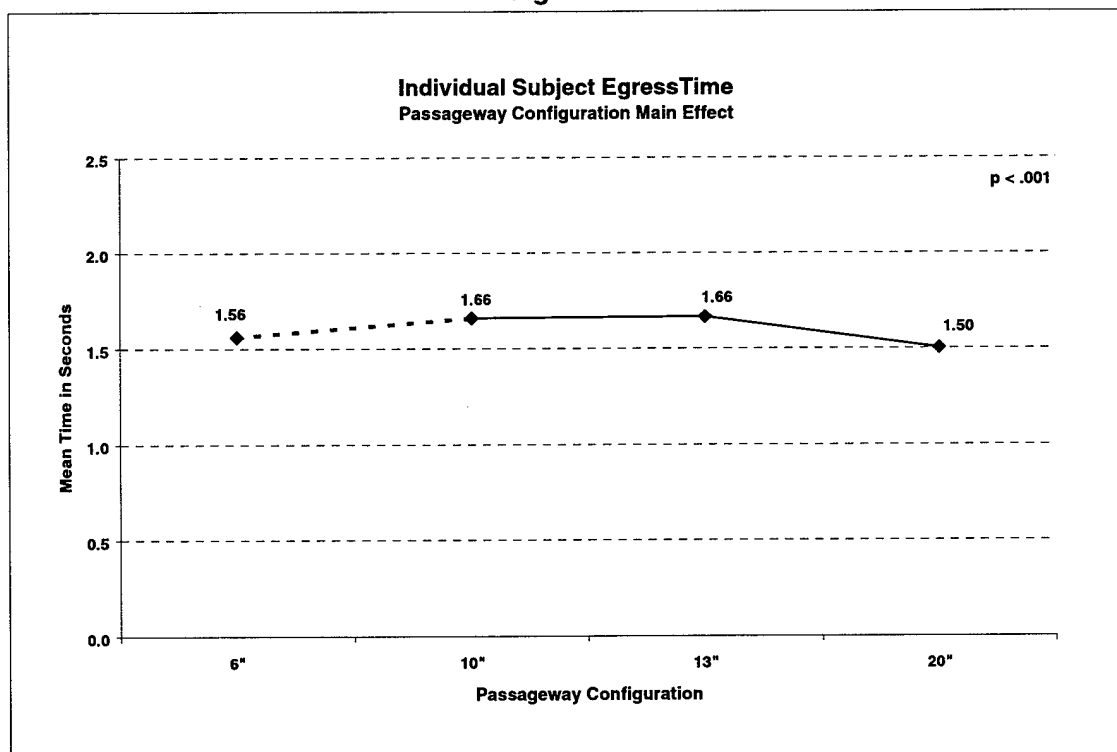

Figure 24

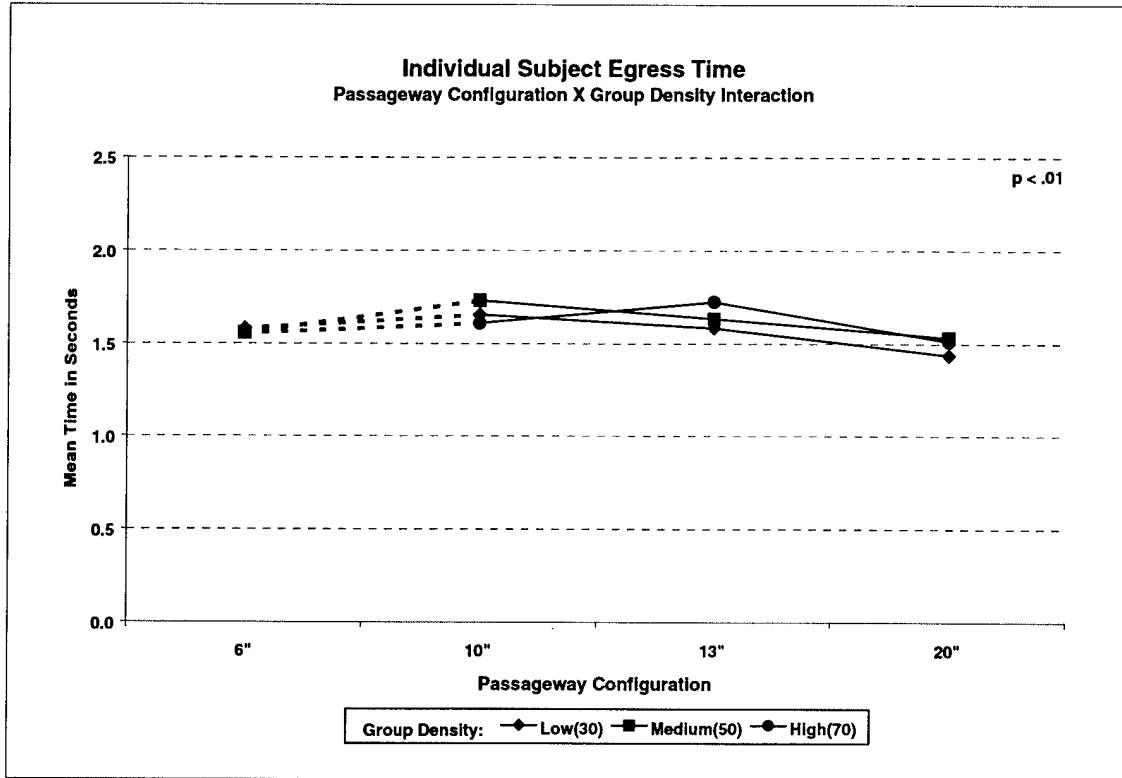

Figure 25

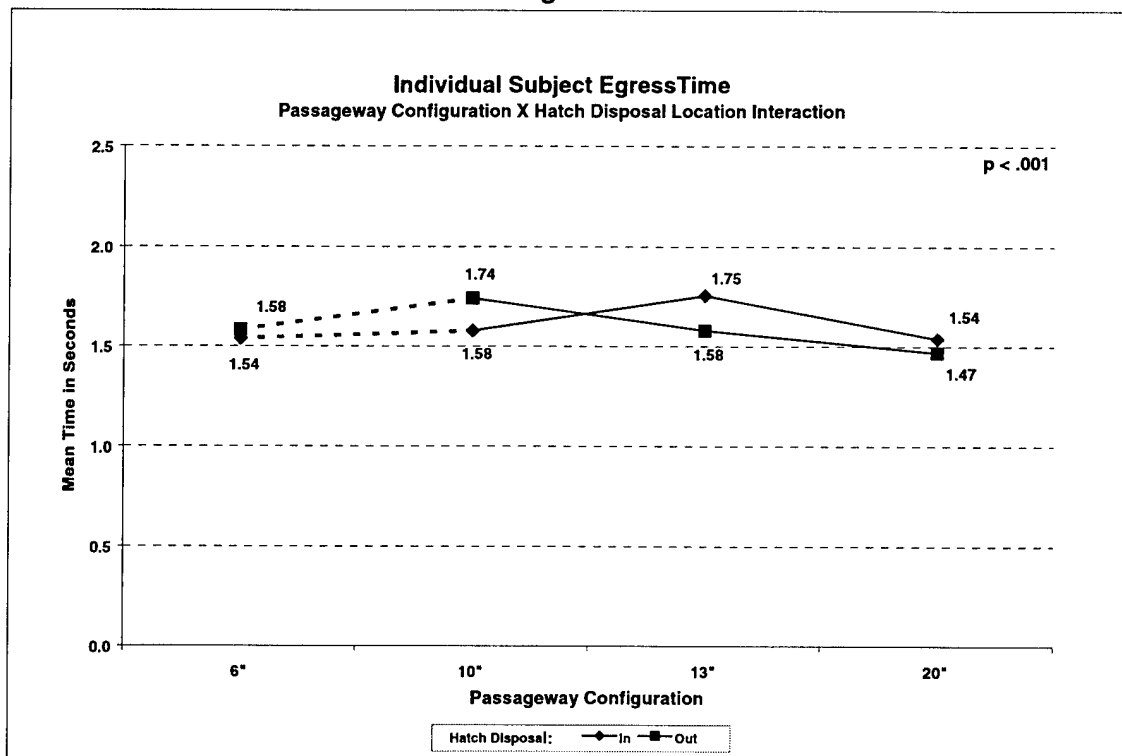

Figure 26

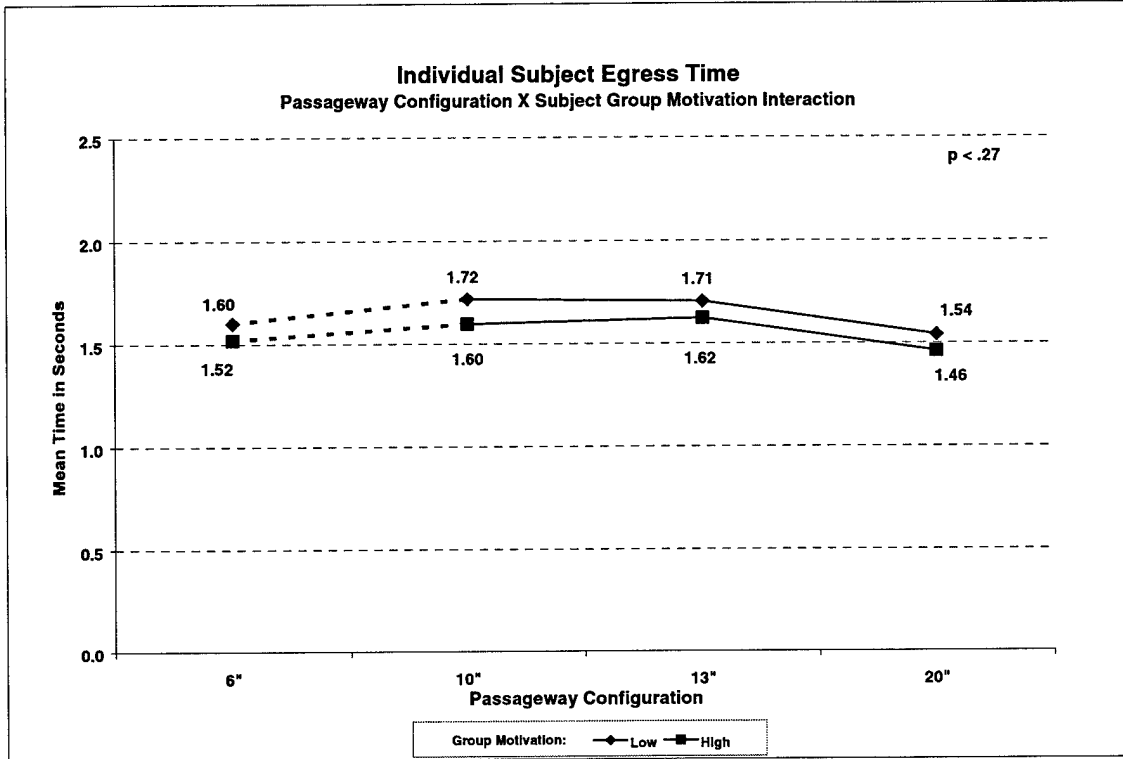

Figure 27

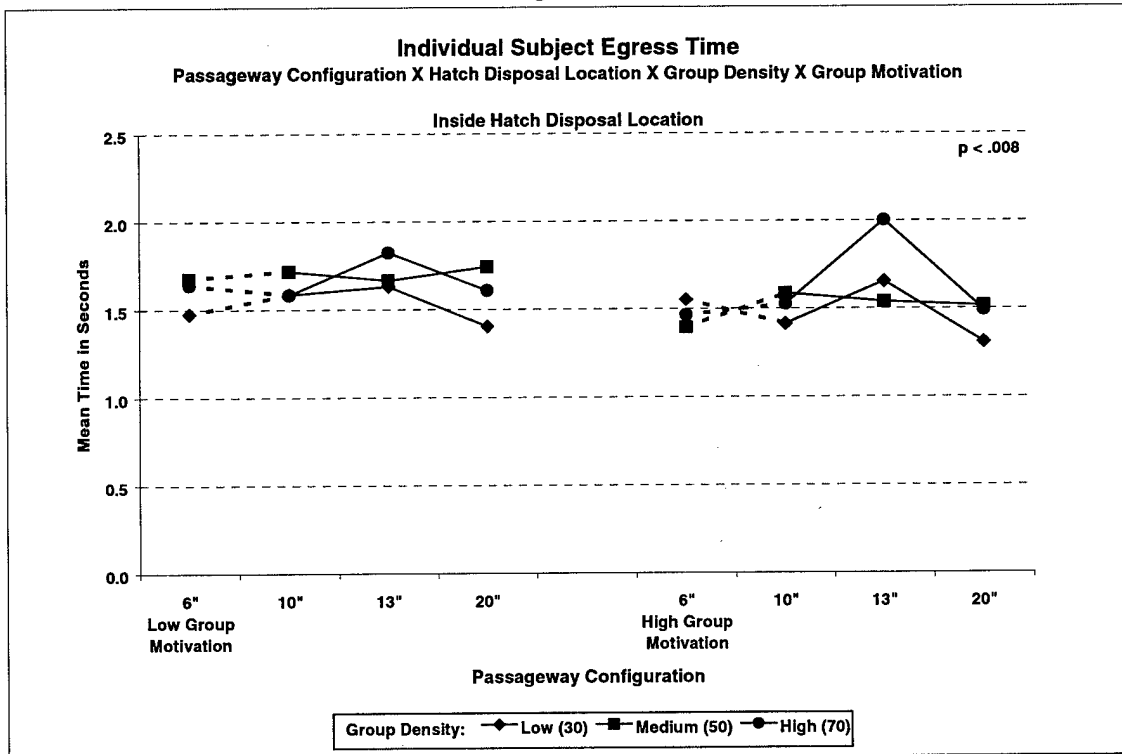

Figure 28

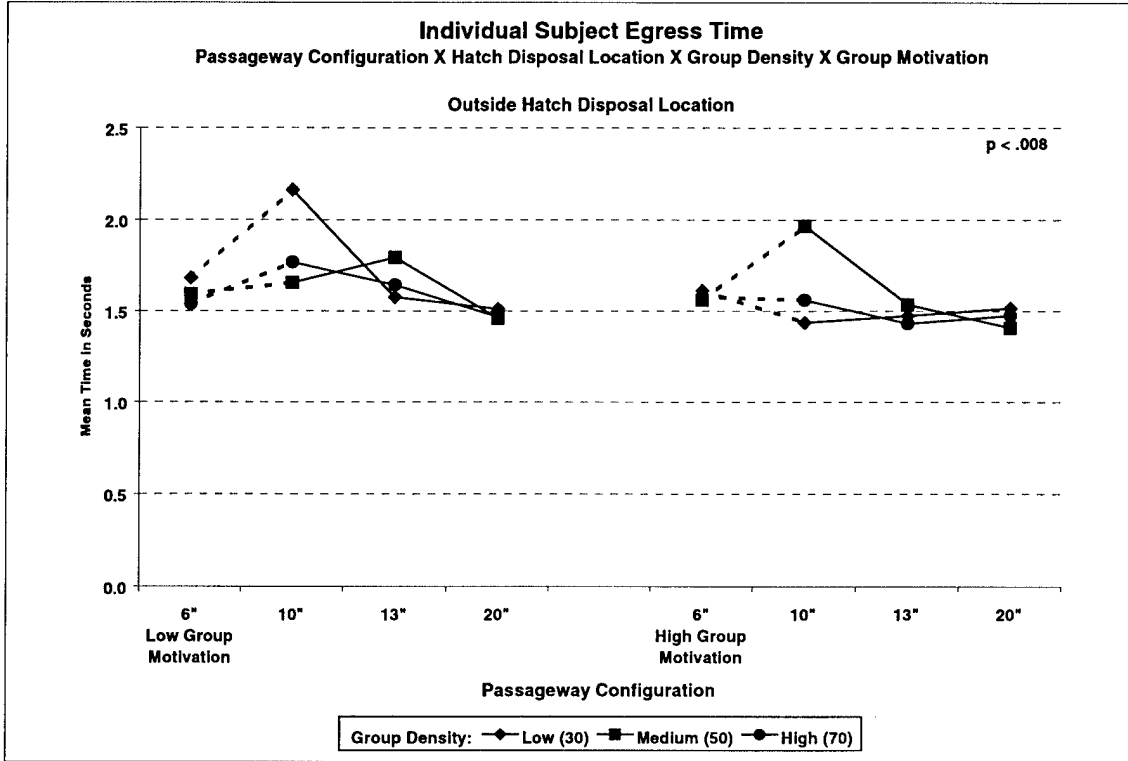

Figure 29
Exit Obstructed by Hatch



cushion, landing longitudinally with respect to the exit and forming a *slide* to the exit (see Figure 30) that slowed the evacuation until the 39th subject to egress threw the hatch outside. Together, these 2 trials significantly inflated the mean individual subject egress times in the 13" passageway configuration and produced several of the egress time outliers in the 13" passageway configuration.

Since the results of these trials depended not on passageway configuration, per se, but on partial obstruction of the exit caused by improper hatch disposal, an adjustment to the mean egress times for those 2 trials was made to remove the temporal influence of the obstructions. This statistical compensation brought the mean times for those 2 trials more in line with the other 13" passageway configuration results, thereby eliminating the 13" component of the passageway configuration main effect, as well as the significance of the interaction between passageway configuration and both hatch disposal location and subject group density. This left only the egress times from the 10" passageway configuration with outside hatch disposal location as being significantly different from the rest.

Human Subject Effects. Upon arrival at the laboratory, subject age and gender were recorded, and subjects were measured to obtain their weight, waist size, and height. All measurements were taken with subjects wearing street clothing and shoes, which slightly inflated the recorded dimensions. Because weight and waist size were so highly correlated ($r = .90$), but weight was not correlated significantly with height, waist size is reported here to distinguish the effects of subject width versus subject height.

Subsequent to the multiple regression and ANCOVA analyses described above, the individual subject characteristics were categorized to provide interval data that would unveil more discrete views of the subject effects. Five subcategories of age, waist size, and height, distributed to achieve a similar number of subjects per subcategory, were created in addition to gender. These grouped variables were then combined with passageway configuration, the only significant independent variable, and analyzed for interactions by 5-way ANOVA.

Not unexpectedly, significant main effects were replicated for waist size ($p < .0001$; Figure 31) age ($p < .0001$; Figure 32), gender ($p < .0001$; Figure 33), and passageway configuration ($p < .031$); subject height

Figure 30
Slide to Exit Formed by Hatch



also reached marginal significance ($p < .03$; Figure 34). There were no significant interactions among any of the individual subject characteristics; nor were there 2-way interactions between passageway configuration and any of the individual subject characteristics (see Figures 35-38). However, there was a (3-way) passageway configuration by gender by age interaction effect ($P < .005$; Figure 39), that appeared to result from shorter egress times for older males, relative to older females, especially with the 6" and 20" passageway configurations. The importance of this distinction was not that older males appeared to be faster than older females in those 2 particular passageway configurations, but that the regression toward the grand mean for the entire group of older subjects, produced for whatever reason by the relatively shorter individual egress times of those older males, might have masked the significance of an interaction between passageway configuration and subject age typical of older individuals. This appeared to be the case, since older male subject egress times with both the 10- and 13-inch passageway configuration were greater than those of their younger cohorts, as well as being quite similar to those of the older females.

Significant interactions between passageway configuration and the other (older) subject characteristics might have also been obscured, given the significant positive correlations ($p < .01$) of both waist size and (unexpectedly) height with age.

To investigate this possibility, simple effects analyses were conducted for the interactions of passageway configuration with all subcategories of all individual subject characteristics investigated.

A simple effect of passageway configuration ($p < .005$; Figure 40) was found for subjects older than 42 years of age, who were significantly slower to egress with the 10" passageway configuration, relative to the other passageway configurations. Subject waist sizes greater than 38" produced essentially identical effects ($p < .02$; Figure 41). The effect of passageway configuration on subjects whose height was greater than 6 feet tall was also found to be significant ($p < .001$; Figure 42), as egress was slowed for those subjects with both the 6" and 10" passageway configurations. These results confirmed that, in particular, the 10" passageway configuration was remarkably more difficult for older, wider, and taller subjects to use, especially subjects in whom these characteristics were combined.

The results also led to revisiting the significant (4-way) passageway configuration by hatch disposal location by subject group density by subject group motivation interaction effect on individual subject

Figure 31

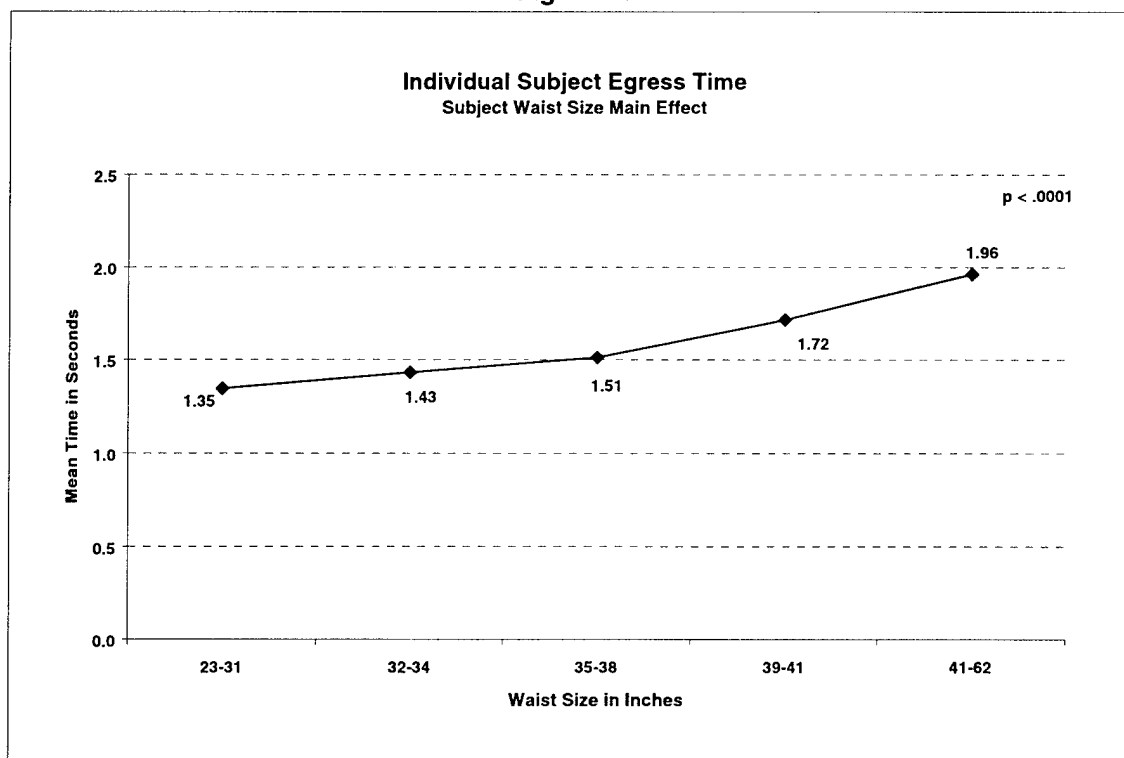

Figure 32

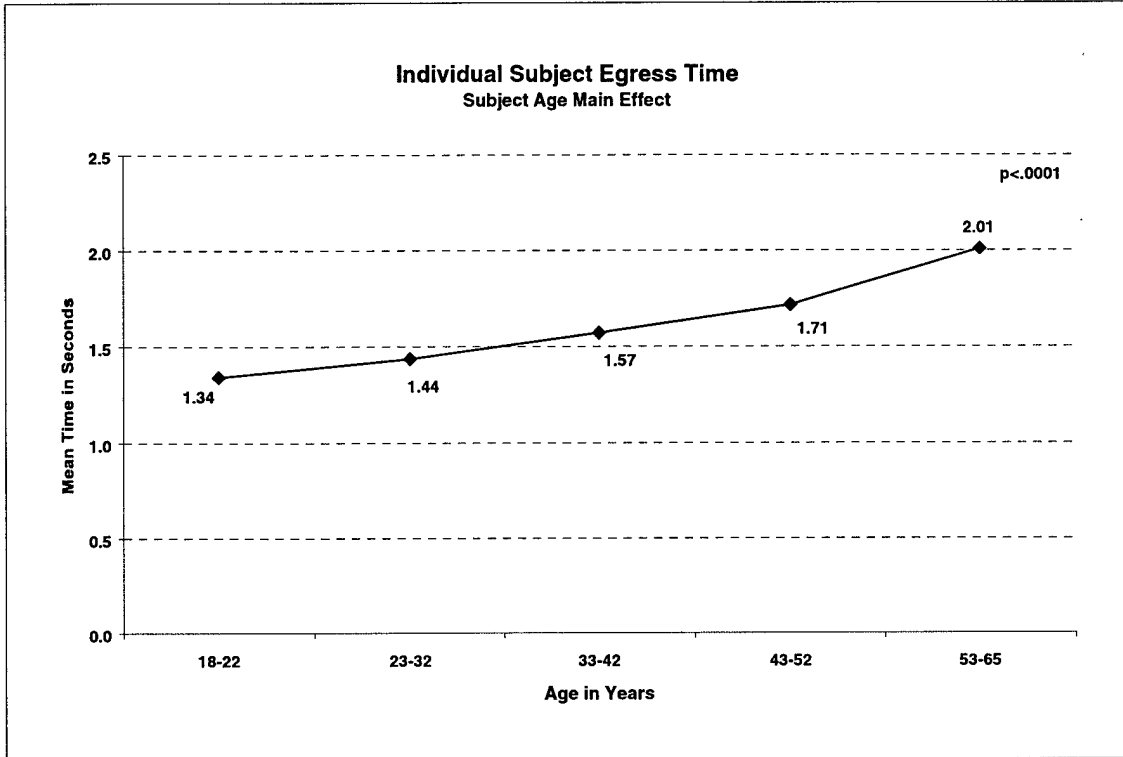

Figure 33

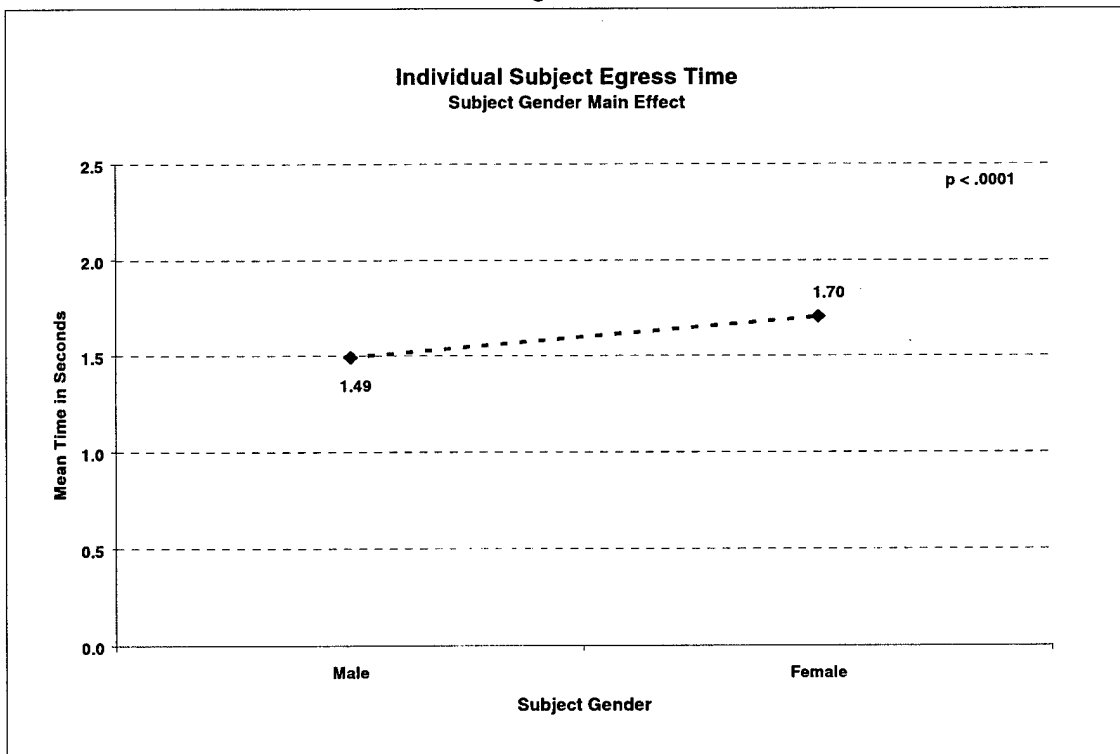

Figure 34

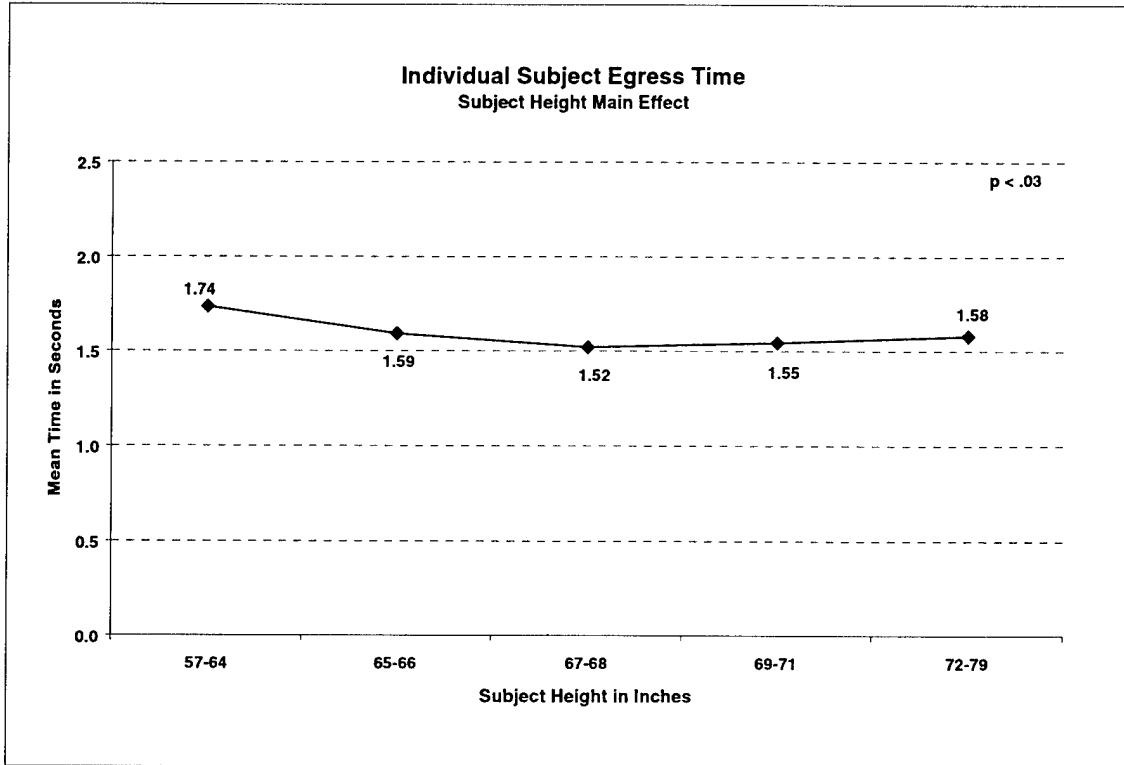

Figure 35

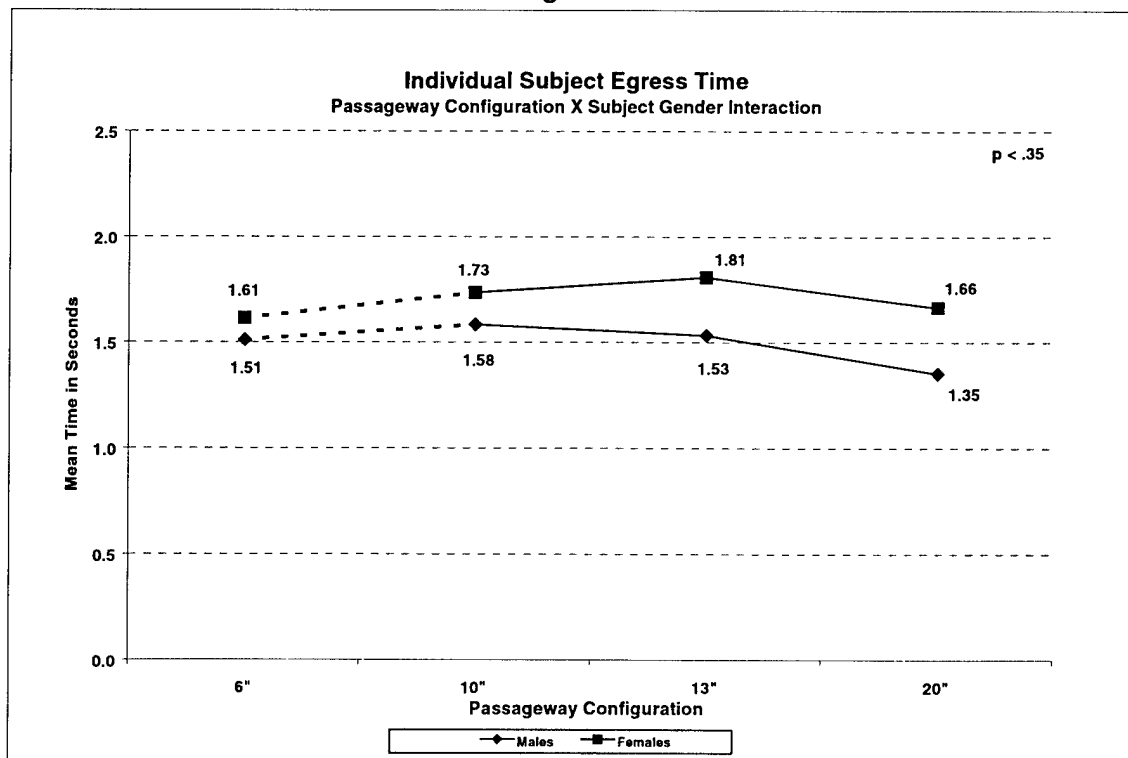

Figure 36

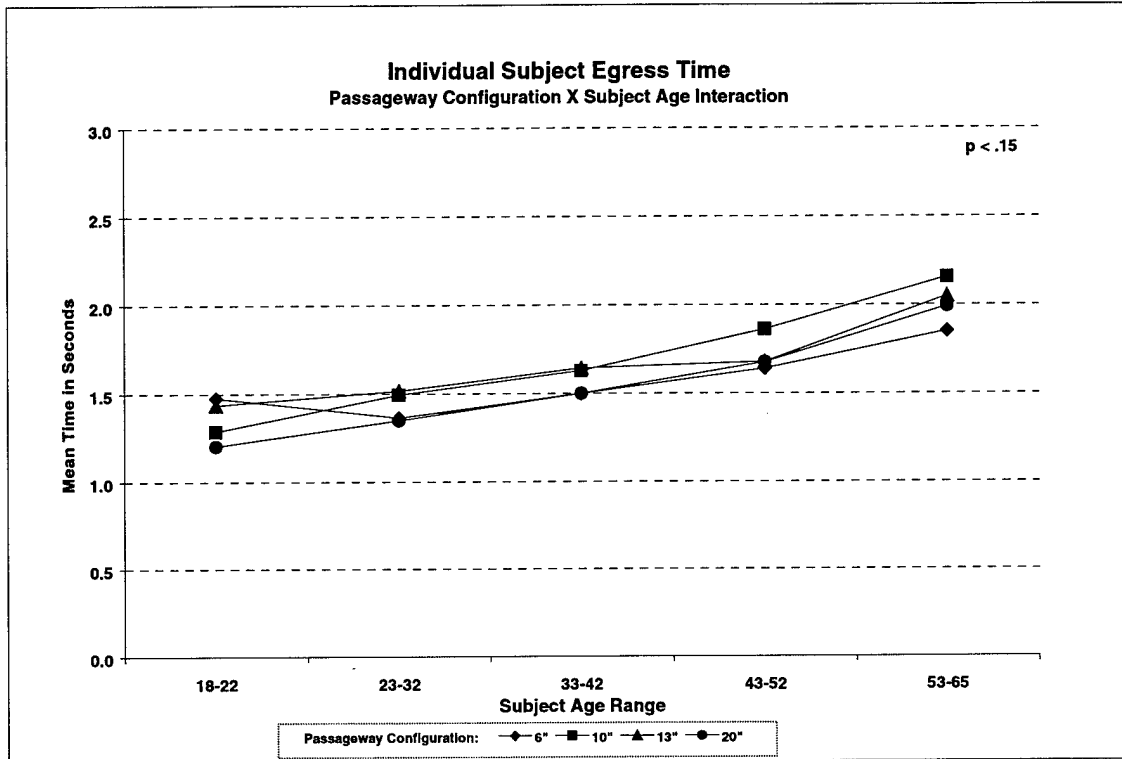

Figure 37

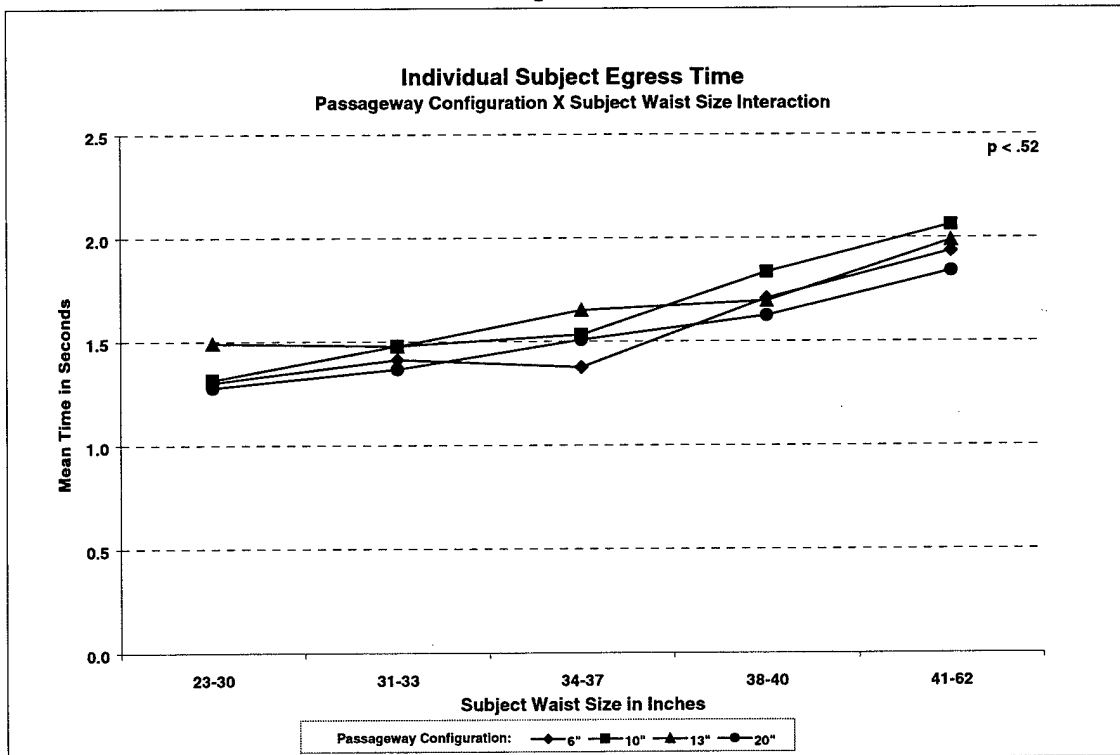

Figure 38

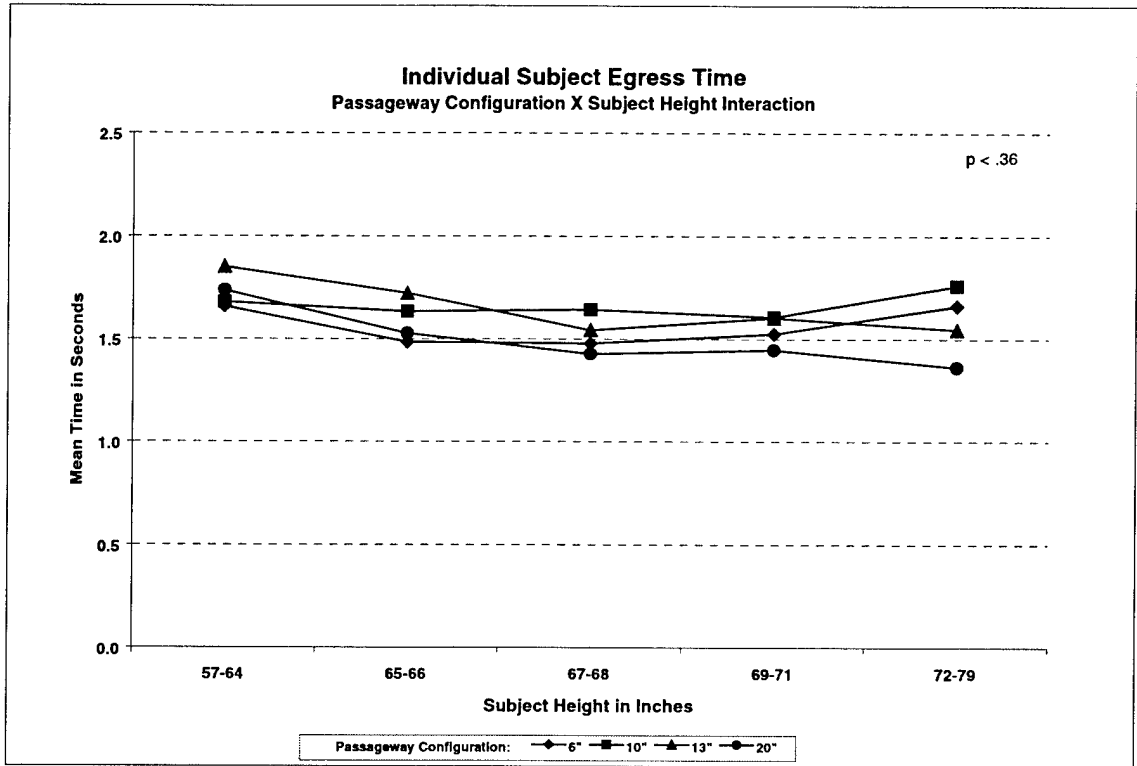

Figure 39

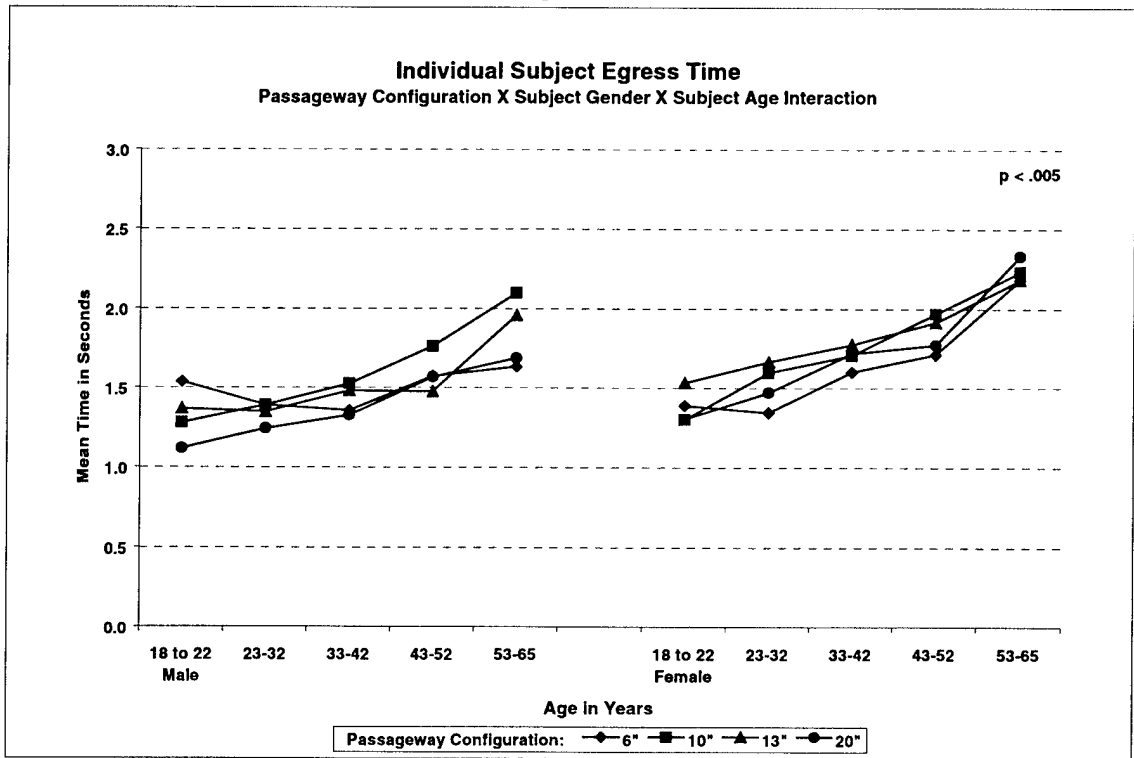

Figure 40

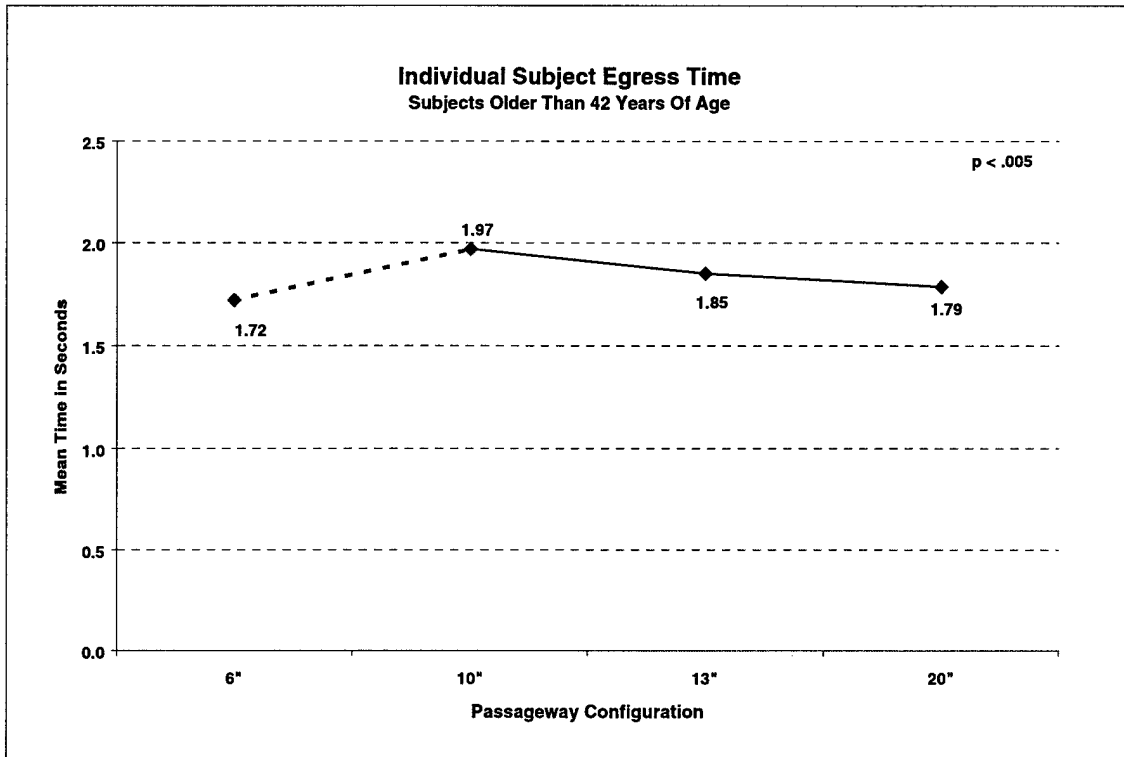

Figure 41

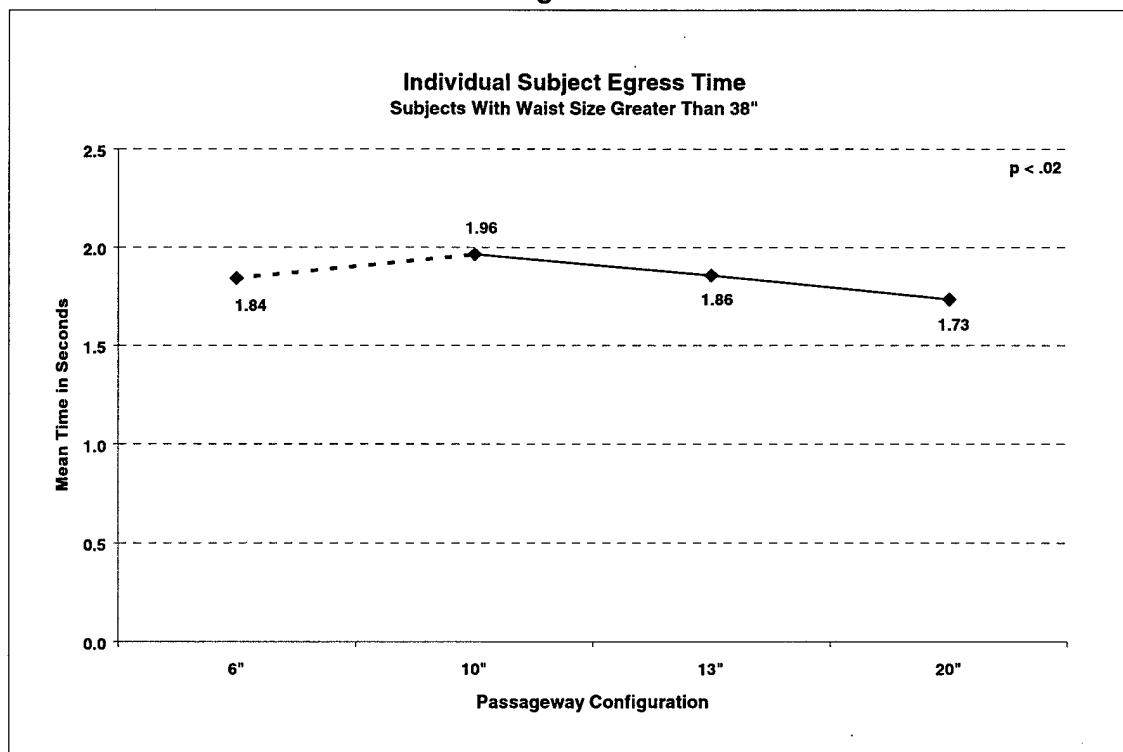
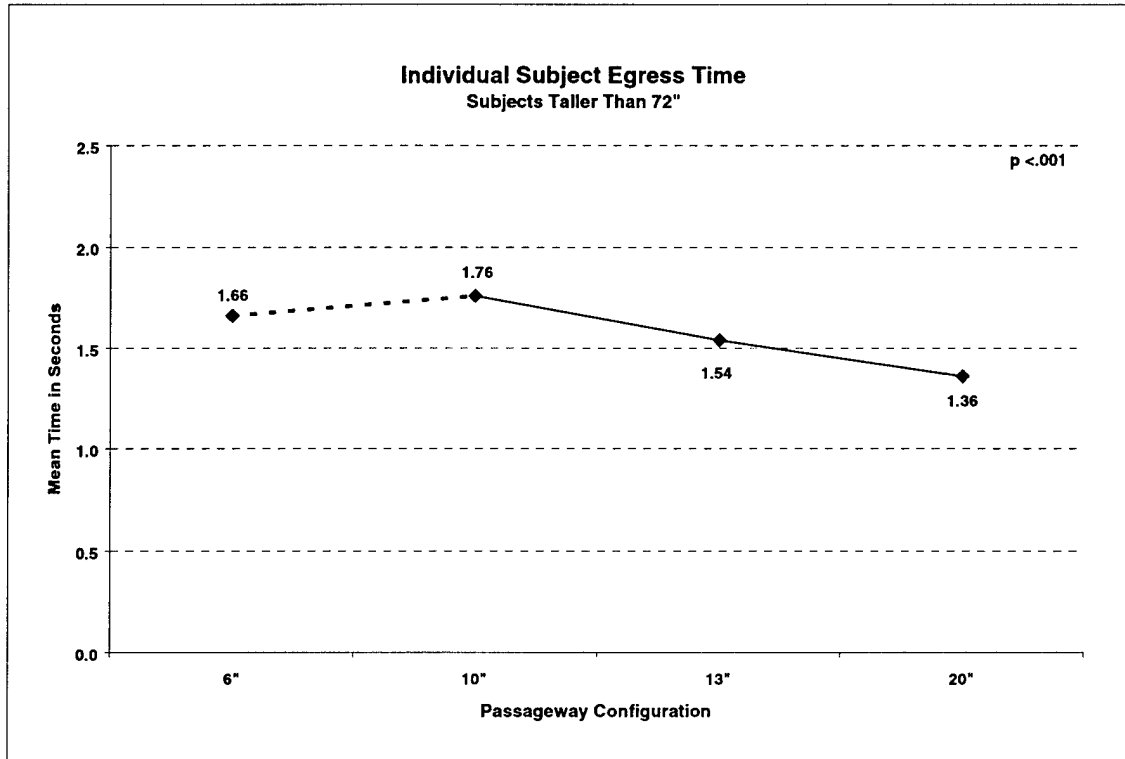

Figure 42



egress times, which had been shown earlier to be partially dependent on limited hatch-produced obstructions of the exit with the 13" passageway configuration (Figure 27). In addition to those effects, there had been an additional component of that interaction effect dependent on elevated egress times with the 10" passageway configuration with outside hatch disposal (see Figure 28). The simple effects described above for the older, wider, taller subjects with the 10" passageway configuration suggested that another review of the videotapes, examining the characteristics of the subjects in the 10" passageway configuration trials with outside hatch disposal for the low-motivation, low-density group and the high-motivation, medium-density group, might shed further light on this higher-order interaction.

The videotape review revealed that subjects in the low-motivation, low-density condition appeared to be generally in much less of a hurry than was typical; and they almost all adhered to the "step-through-foot-first" command used continuously by the flight attendants. This combination produced generally-slowed individual egress times. The high-motivation, medium-density group included a preponderance of overweight (wider) females, who were also more clumsy than usual, that combination producing generally-delayed egress for themselves and those who immediately followed. Together, this situation seemed to

create a between-groups imbalance in subject behavior and the distribution of individual subject characteristics, and this imbalance appeared to be responsible for the 10" passageway configuration component of the higher-order interaction effect. Statistically compensating for this bias, as was done by adjusting the individual egress times for the 13" passageway configuration confounded by improper hatch disposal, eliminated the residual significance of the passageway configuration main effect, as well as the significance of the remaining interaction effects found among the independent variables.

This mathematical procedure controlled for the variance induced by the imbalance in the between-groups distribution of behavioral and individual subject characteristics, recapitulating the initial multiple regression analysis, by targeting specific cells in the research design for which waist size, gender, and age were in control of the mean individual egress time. Thus, the multiple regression analysis alone would have been sufficient to demonstrate the significance of the various egress factor effects on individual subject egress times. However, without having completed the subsequent analyses, there would have been an inability to describe as fully the various interactions among all of the factors that influenced the evacuations, especially the contributions of the human subject characteristics.

To complete the description of the importance of the various effects, the amount of variance attributable to each independent variable and human characteristic, as well as that attributable to their interactions, has been displayed graphically in Figure 43. There, the preeminent significance of individual human subject characteristics in the control of the evacuations is clearly demonstrated.

Evacuation Discussion. The effects on evacuation performance described above replicate fully the research program findings on access to the Type-III exit recounted by McLean (2001). In sum, the specific cabin interior configuration at the Type-III overwing exit was again shown to be of little significance in emergency evacuations, as long as ergonomic minimums were respected. In contrast, the effects of human subject characteristics were shown to be particularly significant, especially those characteristics related to ergonomic considerations. The outermost cases of both configural and human subject variables accounted for the overall significance of any particular egress factor, as it related individually to evacuation performance, as well as its interactions with the other egress factors that influenced the evacuations detrimentally.

The independent variables employed in this study, especially passageway configuration, were typical of those used in previous investigations. The primary research question had been whether the current regulatory requirement, i.e., the 20" passageway configuration with 5" aft seat encroachment, provided more efficient evacuations than the other configurations studied. The significant main effect of passageway configuration appeared to confirm that possibility for the single passageway configurations, although the actual differences in individual subject egress times evidenced among the different passageway configurations rendered the significance much more statistical than practical. In fact, it was the enormous statistical power of the research design that allowed very small differences in egress time to achieve significance. As shown in Figure 43, the proportion of the identified effects on evacuation time that passageway configuration generally represents is challenged for insignificance only by the effects of the other independent variables and individual subject height.

The interactions between passageway configuration and the other independent variables also appeared initially to suggest important interactive constraints on egress. As indicated above, however,

Figure 43

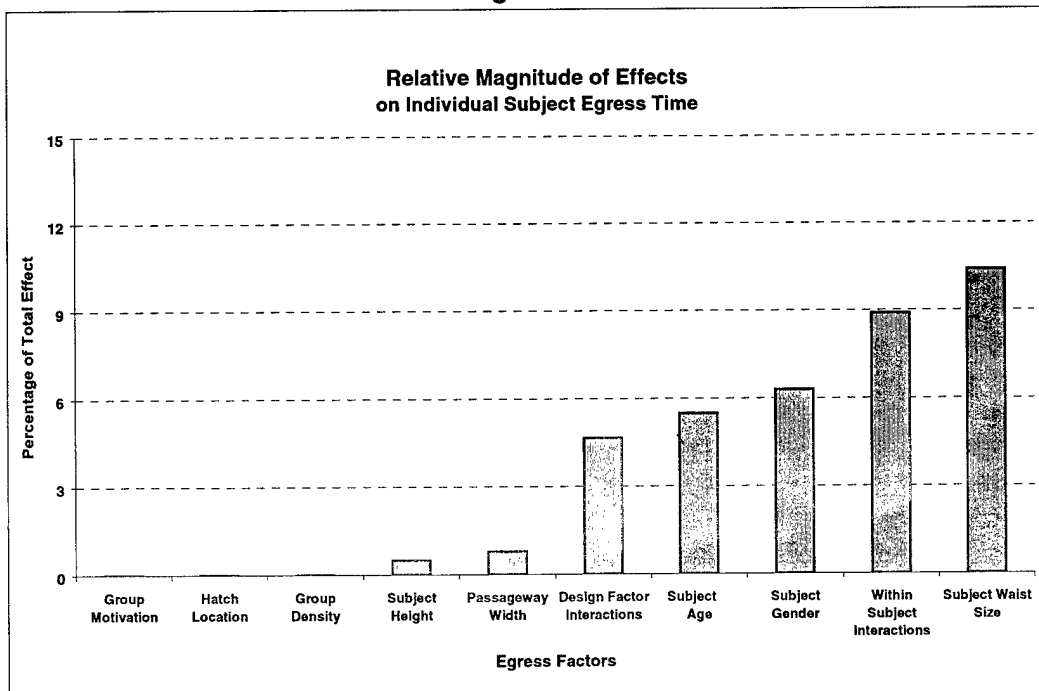

these interaction effects were actually dependent only on limited obstructions of the exit opening produced by a couple of errant hatch disposal attitudes with the 13" passageway configuration that belie the general lack of significance found for hatch disposal location. Although such hatch disposal problems could be potentially injurious in actual practice, solutions aimed at preventing hatch-produced exit obstructions could be implemented to avert that possibility. Among these would be hatches that are automatically stowed outside the evacuation path upon opening or an operational principle that requires the hatch to be discarded outside the airplane when cabin interior configurations more easily promote potential exit obstructions. Any specific solution would need to be chosen with full consideration of the seat encroachment distance in a particular configuration.

A prejudicial combination of behavior and individual subject characteristics in two subject groups using the 10" passageway configuration produced an apparent interaction between passageway configuration and subject group density, as reflected in exceptionally slowed egress in the 2 related trials. Controlling for this imbalance of individual subject characteristics eliminated this effect to illustrate more properly the average contribution to egress time of passageway configuration. Interestingly, however, it was this imbalance in the between-groups distribution of individual subject characteristics that suggested further examination of the simple interactions between passageway configuration and specific human subject characteristics. The character of these effects showed clearly that, of the single passageway configurations employed, only the 10" passageway configuration produced ergonomic restrictions significant with respect to egress performance, specifically for older, wider, and taller subjects. These results replicate those described by McLean and George (1995), and attest again to the inability of the 10" passageway configuration to provide an egress route that is as effective or as efficient as the other configurations for a significant portion of the flying population.

The expected effects of subject group motivation level on individual egress times failed to materialize, as the average difference in egress times between high- and low-motivation groups was small. Unexpectedly, the high-motivation groups were slightly faster than were the low-motivation groups, a finding not previously reported. In fact, prior use of financial incentives to achieve highly motivated subjects generally resulted in a large degree of behavioral chaos that often produced jammed exits that slowed egress significantly. While some amount of chaotic behavior

was evident in the current study, that type of behavior typically occurred in the latter evacuation trials for each group.

In addition, the differences in behavioral intensity between group motivation levels appeared to be less than seen previously. There appeared to be three factors that produced these differences in results. First, the pre-trial briefing in the current study included a statement read to each group immediately before each trial that had not been used before; i.e., "Remember, the airplane has crashed and is on fire, and to stay alive we must get out of here as fast as we can. HURRY!" This admonition appeared to energize the low-motivation level subjects beyond what had been typical, as they often climbed across seats to approach the exit in much the same way as the high-motivation level subjects. Second, the current study employed two professional flight attendants on every trial. They herded the subjects toward the exit from both the front and rear of the cabin, and their general attitude and skill in commanding the evacuations was exemplary. Their ability to verbally *adjust* subject behavior at the exit was considerable, and whenever an exit became nearly jammed, they would augment their command set to include "One at a time! One at a time!" This appeared to reduce the incidence of jamming significantly. Third, and perhaps most importantly, the results presented here are restricted to data from the first trial for each group (in which all subjects were truly naïve). It appeared that only after subjects had completed the first, and subsequent, trial(s) did the high-motivation groups become fully aware of how *competitive* they could be, which progressively exacerbated the behavioral chaos in latter trials.

Combined, these factors produced a situation in which the high-motivation level subjects seemed to benefit from the lure of financial incentives, performing as fast as possible, without the jamming and interruptions in egress produced by overly aggressive behavior associated with *repeated* high-motivation evacuation trials. Comparisons of motivation level effects in the current study with those found in previous (repeated-trial) studies will await the repeated-measures analysis of motivation-level effects in the current study.

Of much greater significance overall were the individual subject characteristics, which accounted for 32% of the variance in the results, when within-subjects interactions are included. Subject waist size was the most significant predictor of individual subject egress time, as wider subjects had more trouble negotiating the exit opening. It should be noted that one subject, who weighed 416 pounds, still managed

to traverse the exit with minimal difficulty, if not great speed. Gender was the next most significant individual subject characteristic following waist size, as females were revealed to be slower to egress than males. Mean differences in athleticism have generally been considered responsible for this much-replicated finding. Advanced age also slowed egress significantly, again because of the reduced agility attendant to aging. While subject height was only of marginal significance, generally increased egress times were seen for short (legged) females who had difficulty with the step-up and step-down required for egress through the exit. Males taller than 6 feet were significantly slowed in the most restrictive passageway configurations. The interactions of the human subject variables also added significantly to their influence on evacuation performance. As seen in previous studies, the combination of female gender with advanced age and large waist sizes was particularly harmful vis-à-vis evacuation performance through the Type-III exit.

Thus, the effects of both configural and human subject variables replicate and extend those found in prior studies, particularly the investigation by McLean and George (1995). That study employed a *practice* protocol to control individual subject performance variability in a split age group, repeated-measures research design that received controversy for its statistical combination of the data from the two age groups and, by implication, its rumored lack of generalizability to the naïve flying public. In fact, the large between-groups design employed in the current study was implemented specifically to address the age stratification issue, as well as the behavioral inconsistency that the practice protocol was used to eliminate.

The report of that 1995 study includes a graph (Figure 9), similar to the one illustrated here in Figure 43, which shows the partitioning of the variance attributable to human subject characteristics. Comparison of the figures shows the relationships among the individual subject characteristics to be very similar for the two studies. The small differences that were expressed relate to the relative strength of effects of the within-subjects characteristics in both studies, and are apparently related to the smaller number of subjects (74) and the more truncated range of subject characteristics employed in 1995. Importantly, the larger subject sample used here provided increases in both statistical power and diversity of subject characteristics that authenticate the more modest 1995 results, reinforcing their generalizability. Combined, these studies clearly delineate the effects of individual human subject physical characteristics on evacuations through the Type-III overwing exit.

In addition to the significance of these human subject characteristics in controlling egress through the Type-III exit, the naïveté that predominates in actual emergency evacuations, i.e., a lack of the knowledge, experience, and skill that would promote evacuation efficiency, has also been shown to be paramount. The effects of subject naïveté were clearly identified in the meta-analysis by McLean (2001) as the primary undercurrent in the findings of the lengthy Type-III exit evacuation research program; however, any ability to uncover the specific contributions of limited subject knowledge and behavioral inexperience has been hindered by the lack of pooled raw data by which to make statistical comparisons among studies. Importantly, differences between laboratories, research techniques, and subject populations could minimize the validity of any such analyses.

The performance effects of naïveté are generally hidden in the residual, unapportioned variance in the results typically referred to as the *error* variance, i.e., the proportion of the results for which no cause can be ascribed. In terms of the current study, the cumulative amount of variance that can be attributed to the investigated egress factors is almost 38%, which leaves about 62% of the total variance to be partitioned, if possible. Without the program of research already conducted on evacuations through the Type-III overwing exit, especially the study by McLean and George (1995), the ability to explain any part of this unapportioned variance would likely go wanting. However, the practice protocol used in that 1995 study allows instructive comparisons of the differences in the magnitude of the human subject effects between studies, potentially revealing the variability in performance associated with naïveté and behavioral inexperience. Note that both studies were conducted by the same principal investigator, in the same airplane simulator, using the same evacuation procedures and controls, and drawing subjects from the same general population. Thus, similarity of the residual, unapportioned *true measurement error* in both studies is likely, allowing an estimate of the variability *conserved* through evacuation experience to be made.

Recall that the current research protocol used a between-groups research design in which a single individual egress time was collected for 2,352 totally inexperienced subjects. As described above, the amount of between-subjects variability was huge. In contrast, the 1995 research protocol included only 74 subjects who were allowed to reach asymptotic egress performance prior to the start of data collection, which assembled individual egress times for every subject in 33 separate evacuation trials. This repeated-measures

design produced a set of about 2,400 individual egress times, i.e., an equivalent database for comparison with the current results.

Regarding the amount of variance explained in each study, the within-subjects design has a computational advantage, as the associated analysis of individual egress times adjusts for the common covariances resulting from repetitive use of the same subjects. In contrast, the analysis of between-subjects data uses only one data point for each subject and, therefore, cannot benefit from this procedural advantage. The extensive set of practice-enhanced individual egress time clusters for each subject in the 1995 study makes the application of this covariance adjustment even more effective, by reducing the actual variability in individual egress times to highlight the proportion of the results dependent on the physical characteristics of individual subjects.

Thus, 71% of the total variance in the (1995) McLean and George study was explained by the effects of individual subject characteristics, in addition to a small amount of variance contributed by passageway configuration. In the current study, passageway configuration maintained its very small contribution, as all of the independent variables together accounted for only about 6% of the total variance in the results. The proportion of the results attributable to individual subject characteristics was only 23%, with the interactions among these individual subject characteristics responsible for another 9% of the variance in the results. Assuming that the amount of unexplained variance produced by the *true measurement error* in both studies is essentially equivalent, around 35 - 40% of the total variance in the current study is based primarily on the effects of naïveté, i.e., procedural and behavioral inconsistency produced by inexperience and a lack of egress skill.

This inconsistency was evidenced in the compounded behavioral disorder seen in the current evacuations, which included struggling for position in the egress queue near the exit, climbing over the seats fore and aft of the passageway(s), shoving and pushing at the exit proper, and getting jammed within the confines of the exit opening together with one or more other subjects. Other behavioral variability in the results was produced by subject *misteps* such as approaching or traversing the exit awkwardly, getting a foot caught between the seats or between the seat and the inside fuselage panel, head bumping into the overhead bins and/or the exit frame that caused redirection and second attempts to egress, getting tangled up with other subjects, and falling onto the winglet outside the simulator, all of these hindering individual

egress differentially. While actual quantitative measurement of the specific contributions imparted by these idiosyncratic events is unfeasible, i.e., it remains actual *error* variance, comparison of the results from these 2 studies reveals the negative influence that naïveté has on evacuation performance and the improvements in evacuation effectiveness and efficiency that occur when egress performance becomes more regimented through knowledge and, particularly, experience.

Improvements in Type-III exit hatch operation in the current study, similar to the improvements seen for evacuation performance in the McLean and George (1995) study, were produced by compelling the hatch operators to review the safety briefing card prior to their evacuation trials. Both hatch operation and selection of hatch disposal location appeared to benefit from this improved educational experience. These enhancements in operational effectiveness, based only on better information, suggest that superior evacuation outcomes can be achieved in actual transport category operations by the provision of enhanced passenger education and training. Specific investigations of alternative methodologies have already begun, and the development of more effective educational materials needs to be accomplished. Strategies related to the application of these activities must also be defined.

CONCLUSION

These findings reinforce those that have come before. The effects of cabin interior configuration adjacent to the Type-III exit are minimal, as long as ergonomics minimums are respected. Such effects are completely overshadowed by what can best be described as a *tour de force* in human subject variability. Differences in the physical and psychological characteristics of research subjects, as well as the naïveté that engenders significant behavioral variability, function in almost direct opposition to the notion that problems with emergency evacuation through the Type-III exit are generally produced by restrictive cabin interior configurations. These findings restate the need to address the conventional airplane emergency evacuation problem for what it really is — a failure of passengers to understand and properly execute emergency procedures. The time has now come to move on to a search for better information and more effective passenger education and training techniques that will lead to safer and more productive emergency evacuations/survival.

REFERENCES

- Department of Transport, Aircraft Accident Investigation Branch, Report on the Accident to Boeing 737-236 Series 1, G-BGJL at Manchester International Airport on 22 August 1985, (AAIB Report 8/88), London, 1998.
- McLean, GA, Access-to-Egress: A Meta-Analysis of the Factors That Control Emergency Evacuation Through the Transport Airplane Type-III Overwing Exit, Office of Aerospace Medicine Report, DOT/ FAA/AM-01/2, Washington, DC: FAA, January 2001.¹
- McLean, GA and MH George, Aircraft Evacuations Through Type-III Exits II: Effects of Individual Subject Differences, Office of Aerospace Medicine Report, DOT/FAA/AM-95/25, Washington, DC: FAA, August 1995.¹
- Muir, H, D Bottomley, & J Hall, Aircraft Evacuations: Competitive Evacuations in Conditions of Non-Toxic Smoke, Civil Aviation Authority, UK, CAA Paper 92005, March 1992.
- National Transportation Safety Board, Aircraft Accident Report, Runway Collision of USAir Flight 1493, Boeing 737 and Skywest Flight 5569 Fairchild Metroliner, Los Angeles International Airport, Los Angeles, California, (NTSB/AAR-91/08), Washington, DC: NTSB, February 1, 1991.
- National Transportation Safety Board, Emergency Evacuation of Commercial Airplanes, Safety Study NTSB/SS-00/01, Washington, DC: NTSB, 2000.
- SPSS Base 10.0 Applications Guide, SPSS Inc., Chicago, IL, 1999.
- Transport Canada Personality Profile (TCPP), Version 2, Minister of Public Works and Government Service, Ottawa, Canada, Copyright 2000.

¹ This document can be obtained through the National Technical Information Service, Springfield, VA 22161. It is also available at the Civil Aerospace Medical Institute's Web site: http://www.cami.jccbi.gov/aam-400A/Abstracts/Tech_Rep.htm

Appendix A

TYPE-III EXIT EGRESS OUTLIERS

Motive/ Passageway/ Hatch Location	Order Out	Egress Time (sec)	Z Score	Sex	Age	Waist Size (in)	Height (in)	Egress Details
L - 6 - I	21	4.6	3.15	F	55	36.2	65.4	Step-thru delay
L - 6 - I	11	4.8	3.32	M	46	50.8	71.3	Two tries to get out; step-thru delay
L - 6 - I	1	9.4	8.16	M	42	39.4	65.4	Held onto side of opening to step-thru
L - 6 - O	12	4.6	3.11	F	63	47.2	65.9	Stepped onto sill then decided to step-thru
L - 6 - O	30	6.4	5.00	F	65	37.0	68.7	Step-thru delay; trailing foot got hung up in exit
L - 6 - O	4	7.4	6.09	F	63	39.8	62.7	Had trouble getting foot up to the exit sill
L - 6 - O	14	4.9	3.39	F	55	46.5	67.4	Two tries to get thru exit
L - 10 - I	9	6.7	5.66	M	35	33.1	71.5	Stood on hatch, foot slipped off ; two tries to get thru
L - 10 - I	31	4.7	3.39	F	41	42.9	63.8	Short legs, both feet on sill; sat down to get thru
L - 10 - O	33	4.6	3.21	F	45	43.3	67.9	Step-thru delay, sat on sill & held onto side of exit
L - 10 - O	33	4.9	3.55	F	65	41.7	66.5	Two tries to get feet on sill, jumped thru
L - 10 - O	31	4.7	3.32	M	61	27.6	62.4	Trouble getting both feet on sill; stepped down
L - 13 - I	27	5.7	3.77	F	22	31.9	65.1	Trouble getting on sill, stepped down, hatch in way
L - 13 - I	12	5.4	3.48	F	51	34.3	68.4	One, then both feet on sill; began to step thru & jumped
L - 13 - I	54	5.2	3.23	F	19	25.6	66.9	Both feet on sill then stepped down
L - 13 - I	45	6.1	4.15	F	52	48.4	67.0	Short legs, foot & knee on sill, leaned back, step-thru delay
L - 13 - O	13	6.0	4.05	F	63	45.7	69.1	Step-thru delay; trailing foot got hung up on exit
L - 20 - I	28	6.4	5.75	F	54	43.7	60.9	Step-thru delay, held onto side of exit, trailing leg caught
L - 20 - I	29	5.0	4.02	F	59	45.7	66.4	Short legs, put foot on sill, then stepped down
H - 6 - I	3	7.1	5.71	F	27	32.3	62.0	Fell partly out head first, then regrouped, both feet on sill
H - 6 - I	1	6.2	4.83	F	18	25.6	64.4	Struggled in front of hatch operator; step-thru delay
H - 6 - O	19	6.8	5.39	F	63	46.1	68.5	Trouble getting foot up on sill, step-thru delay
H - 10 - I	69	4.9	3.58	F	56	37.8	63.7	Trailing foot caught on exit
H - 10 - I	32	4.4	3.02	M	57	44.1	69.2	Hatch got in the way
H - 10 - I	23	6.4	5.24	F	65	35.4	62.4	Short legs, step-thru delay
H - 10 - I	27	6.8	5.77	M	49	43.7	67.1	Step-thru delay, trailing leg caught
H - 10 - O	6	5.0	3.66	F	47	35.8	66.8	Foot on sill, bent down, step-thru delay, trailing leg caught
H - 10 - O	48	4.9	3.63	F	50	45.7	67.1	Stood up inside, feet on sill, bent down, step-thru delay
H - 10 - O	12	4.7	3.38	M	52	41.3	73.5	Two people getting out at same time
H - 13 - I	57	8.5	6.40	F	62	43.3	63.6	Sat on hatch, turned, then slid out
H - 13 - I	48	9.2	7.06	F	39	31.9	66.1	Trouble stepping up on hatch & then stepped out
H - 13 - I	14	5.3	3.33	F	25	29.5	68.8	Foot caught on exit
H - 13 - I	5	6.6	4.62	M	26	28.3	71.7	Trailing foot caught on exit
H - 13 - I	1	9.2	7.09	F	18	30.3	66.3	Two people getting out at same time
H - 13 - O	25	5.7	3.77	F	56	45.3	67.3	Knee on sill, leaned backward & stepped down
H - 13 - O	20	7.0	4.94	F	57	39.8	63.2	Trouble getting foot up on sill
H - 20 - I	1	9.5	9.34	F	27	34.3	64.8	Struggled in front of hatch operator; step thru delay
H - 20 - I	1	6.7	6.07	M	29	33.5	71.8	Struggled by the hatch operator & rolled out
H - 20 - O	24	4.2	3.11	F	45	44.5	65.8	Short legs, both feet on sill, bent down & stepped down
H - 20 - O	1	7.3	6.82	M	31	33.5	64.1	Struggled to step in front of the hatch operator
H - 20 - O	50	7.9	7.49	F	31	31.9	64.2	Step-thru delay; trailing foot caught on exit