

REPORT DOCUMENTATION PAGE

Form Approved
OMB No. 0704-0188

Public reporting burden for this collection of information is estimated to average 1 hour per response, including the time for reviewing instructions, searching existing data sources, gathering and maintaining the data needed, and completing and reviewing this collection of information. Send comments regarding this burden estimate or any other aspect of this collection of information, including suggestions for reducing this burden to Department of Defense, Washington Headquarters Services, Directorate for Information Operations and Reports (0704-0188), 1215 Jefferson Davis Highway, Suite 1204, Arlington, VA 22202-4302. Respondents should be aware that notwithstanding any other provision of law, no person shall be subject to any penalty for failing to comply with a collection of information if it does not display a currently valid OMB control number. PLEASE DO NOT RETURN YOUR FORM TO THE ABOVE ADDRESS.

1. REPORT DATE (DD-MM-YYYY)		2. REPORT TYPE Technical Papers		3. DATES COVERED (From - To)	
4. TITLE AND SUBTITLE				5a. CONTRACT NUMBER	
				5b. GRANT NUMBER	
				5c. PROGRAM ELEMENT NUMBER	
6. AUTHOR(S)				5d. PROJECT NUMBER 2306	
				5e. TASK NUMBER MIB3	
				5f. WORK UNIT NUMBER	
7. PERFORMING ORGANIZATION NAME(S) AND ADDRESS(ES) Air Force Research Laboratory (AFMC) AFRL/PRS 5 Pollux Drive Edwards AFB CA 93524-7048				8. PERFORMING ORGANIZATION REPORT	
9. SPONSORING / MONITORING AGENCY NAME(S) AND ADDRESS(ES) Air Force Research Laboratory (AFMC) AFRL/PRS 5 Pollux Drive Edwards AFB CA 93524-7048				10. SPONSOR/MONITOR'S ACRONYM(S)	
				11. SPONSOR/MONITOR'S NUMBER(S)	
12. DISTRIBUTION / AVAILABILITY STATEMENT Approved for public release; distribution unlimited.					
13. SUPPLEMENTARY NOTES					
14. ABSTRACT					
15. SUBJECT TERMS					
16. SECURITY CLASSIFICATION OF:			17. LIMITATION OF ABSTRACT A	18. NUMBER OF PAGES	19a. NAME OF RESPONSIBLE PERSON Leilani Richardson
a. REPORT Unclassified	b. ABSTRACT Unclassified	c. THIS PAGE Unclassified			19b. TELEPHONE NUMBER (include area code) (661) 275-5015

1119 0952

6 separate items are enclosed.

B3

MEMORANDUM FOR PRS (In-House Publication)

FROM: PROI (TI) (STINFO) *5762*
5462

13 October 1999

SUBJECT: Authorization for Release of Technical Information, Control Number: ~~AFRL-PR-ED-TP-199~~ *1999*-0186,
Hoffman, W., Wapner, P.; "Hydraulic Actuation Based on Flow of Non-wetting Fluids in Micro-channels"
Journal Article
(Statement A)

Hydraulic Actuation Based on Flow of Non-wetting Fluids in Micro-channels

By
Phillip G. Wapner
And
Wesley P. Hoffman

Abstract:

The behavior of non-wetting fluids in micro-channels can be utilized to create an unusual form of micro-hydraulic technology that enables fabrication of various kinds of micro-actuators and micro-bearings. In addition, this same technology can be used to construct micro-pumps capable of generating flows of wetting fluids in micro-channels and to manipulate and control these flows.

Text:

Hydraulic actuation and control is a mature technology that is widely used in a variety of applications in the macroscopic world in which we live. Its use in microelectromechanical systems (MEMS), however, is just beginning to be explored. The reason micro-hydraulics is still in its infancy results from the fact that it is not easy to construct miniaturized analogs of macroscopic hydraulic system using traditional MEMS fabrication techniques, such as photolithography or (LIGA). Tight-clearance pistons that do not allow bypass flow, for example, are difficult to fabricate in micro-devices. Fortunately, the very fact that MEMS devices are so tiny enables a very different kind of hydraulic technology to be used. It is based on surface tension and wettability phenomena associated with the flow of non-wetting fluids in micro-channels (1).

The utilization of pressurized incompressible fluids to achieve positive displacements of mechanical devices is a relatively straightforward concept. Motion of a piston within a hydraulic system, for example, will take place providing three conditions are met. First, the pressure applied to the piston by the incompressible fluid must be greater than the force opposing piston displacement. Second, there must be no leaks or fluid bypass. And third, there must be no significant voids in the system. The first condition must be satisfied or motion can not take place. The second condition ensures reproducible pressurization and preservation of the hydraulic fluid, while the third condition guarantees immediate transmittal of pressure in the incompressible fluid to the piston as well as other system surfaces. In macroscopic hydraulic systems, the use of good system mechanical design and construction ensures that the first and second conditions are fulfilled. The third condition is addressed in two ways. First, of all, air bubbles are excluded from the system by careful fluidic layout (i.e., well-placed bleed valves) and precise filling techniques. Second, a hydraulic fluid is selected which wets system surfaces. This is done for a number of interdependent reasons. The primary reason being that if the hydraulic fluid does not wet system surfaces, tiny gaps and crevices will remain empty until sufficient pressure is created within the hydraulic fluid to generate the small-radius convex surfaces needed to fill them. This would be a direct result of the

define

STRICTLY SPEAKING
THIS IS NOT
TRUE
STATEMENT

ensures
only
applies
to
insurance

wordy

this
wasnt
a complet
sentence
the way
you had
it

20021119 095

surface properties of any such non-wetting hydraulic fluid. These gaps and crevices would therefore act as voids similar to air bubbles, resulting in reduced system performance. They would also greatly lessen the ability of the hydraulic fluid to lubricate moving parts and prevent corrosion of the system as a whole. Non-wetting fluids are therefore not well suited for use in macroscopic hydraulic systems.

In microscopic hydraulic systems, the reasons for choosing a wetting versus a non-wetting hydraulic fluid are not as straightforward. That is, as the dimensions of the hydraulic system decrease, pressure within a non-wetting fluid gradually becomes elevated over any externally applied pressure, such as that generated by a piston acting upon the fluid in a cylinder.

Non-wetting fluids, by definition, do not enter into capillaries without pressure being applied. Once a column of such fluid has been forced into a capillary, however, this insertion pressure becomes an integral component of the parameters defining the nature or state of the fluid while it is contained within the capillary. The total pressure, P_t , existing within the column then becomes the sum of the insertion pressure, P_i , and any externally applied pressure, P_{ex} .

$$P_t = P_i + P_{ex} \quad (1)$$

Thus, in micro-hydraulic systems operating with non-wetting fluids, three different pressures must be taken into account. No corresponding situation exists in macroscopic hydraulic systems using either wetting or non-wetting fluids, or in micro-hydraulic systems employing wetting fluids.

The differences resulting from dimensional decrease can be demonstrated by considering a hypothetical hydraulic system employing a non-wetting incompressible fluid such as mercury, with a surface tension of 473 dynes/cm and a contact angle of 140 degrees that is actuated with an externally applied pressure of 100,000 dynes/cm² (i.e., P_{ex} equals 100,000 dyne/cm²) or 1.45 psi. As the scale of such a system is reduced from macroscopic to microscopic size, an interesting crossover point is found. The pressure needed to insert fluid into the hydraulic system, P_i , begins to exceed the external pressure applied to the fluid, P_{ex} , when the radius of system components falls below 100 microns. This is a direct consequence of the Young and Laplace equation governing differential pressure drop across curved liquid surfaces that are not in contact with any other surfaces (2,3):

$$\Delta P_d = \gamma(1/r_1 + 1/r_2) \quad (2a)$$

If the droplet is spherical i.e., $r_1 = r_2$ equation 2a reduces to:

$$\Delta P_d = 2\gamma/r \quad (2b)$$

The associated relationship describing capillary pressure in terms of surface tension and wettability (4) is given by:

*If this is
cm², then the
comma
should be
after
the 2.*

which one?
2a or 2b?
or both?
Say which?
or say
2a and 2b

$$P_i = 2\gamma \cos \theta / r_c \quad (3)$$

In these equations, ΔP_d is the difference in pressure between the inside of a spherical drop and the outside, r is the radius of the spherical surface, λ is surface tension of the fluid, and θ is the contact angle. Equation 2 is applicable whenever a fluid forms a free surface, whether this is a free-falling drop, or a fluid that doesn't wet a solid surface resulting in a sessile drop. The radius of any such free surface produces an inwardly directed pressure due to the unbalanced nature of forces acting on liquid molecules at the surface. This surface results from the fact that molecules in the bulk of the liquid are surrounded by, and attracted to, other liquid molecules in all directions. At the surface, this is not true and the unbalanced interior attractions result in the pressure differential that is often referred to as internal pressure and is detailed in equation 2. It is very important to recognize that whenever a pressure difference exists across a free and unconstrained liquid surface, it must assume a curved geometry having at least one radius less than infinity. The converse is also true, i.e., the presence of a free and unconstrained liquid surface requires that a pressure drop manifest itself across that surface and that it be described by equation 2.

i.e.,

ONE RADIUS?
OK

Equation 3 is derived from equation 2 using a simple force balance carried out along a capillary wall in contact with a fluid whose wetting or contact angle is θ . It allows calculation of the pressure needed to insert a column of fluid into a capillary of radius, r_c . Once this pressure is known, it can be substituted back into equation 2 for the pressure difference between the inside and outside of the column of fluid and then be solved to obtain the radius of curvature of the fluid surface, r , on either end of the capillary. This radius will always be greater than the radius of the capillary unless the contact angle is exactly zero or 180 degrees. For non-wetting fluids, of course, a positive pressure is needed to insert the fluid into the capillary. Once the column is completely contained within the capillary, the insertion pressure does not disappear but remains a very real and measurable component of forces existing within the non-wetting fluid. Its existence is confirmed by observing that the ends of the column, which are free and unconstrained, assume convex shapes that have the form of truncated hemispheres of radius r .

your subject is only in first half of sentence therefore, no comma before "and"

When the radius of our hypothetical hydraulic cylinder, r_c , equals 100 microns, equation 3 indicates that the insertion pressure needed to force a non-wetting column of mercury into such a cylinder is 72,470 dyne/cm² (1.05 psi). Thus, at these dimensions, the pressure needed to create a non-wetting column of fluid, i.e., P_i , is the same order-of-magnitude as the hydraulic pressure hypothetically assumed to exist in such a system. If the radius becomes even smaller, the pressure needed to fill the system can become much larger than the externally applied pressure. This does not mean that the micro-hydraulic system cannot be fabricated. It simply means that some initial insertion pressure has to be employed to form the column of non-wetting fluid. Any external pressure applied after that point, by an actuating piston, for example, is added to the insertion pressure and increases the total pressure inside the fluid. Only the pressure applied externally, however, will be able to perform any external work as long as capillary dimensions in the micro-hydraulic system remain constant. If capillary dimensions vary, the potential

i.e.,

energy contained within the non-wetting column of fluid will also vary, depending on actual geometry employed. This creates the possibility of the non-wetting hydraulic fluid performing more work than is provided by the pressure applied externally to it. This would occur, for example, if a column of non-wetting fluid suddenly entered a capillary having a larger diameter with a piston inside it. The non-wetting fluid would then rush into the larger capillary because the insertion pressure is lower there. By carefully designing such a system, the potential energy contained within the column of non-wetting fluid could be converted to external work performed by the piston. Of, course, the amount of external work that could be performed must be equal to or less than the potential energy created during insertion of the non-wetting column of fluid into the smaller capillary initially. The behavior of non-wetting fluids in capillaries having variable axial geometry does not really fit within the scope of this paper. However, this topic is quite relevant to design of other MEMS devices and is discussed in some detail elsewhere (5).

To illustrate these concepts in greater detail, consider the column of mercury contained within the capillary with a radius of 10 microns illustrated in Figure 1. In Figure 1a, no hydraulic pressure is applied to the mercury column, whereas in 1b an actuating piston is shown pushing the mercury column into a wall. The pressure within the mercury column in 1a is $724,700 \text{ dyne/cm}^2$ (10.5 psi) calculated from equation 3. This is, after all, the pressure needed to insert the mercury into the capillary with a 10-micron radius in the first place. It is also the pressure that the column of mercury exerts on the capillary wall wherever contact is made. The radius of curvature of both ends of this non-pressured column can be found by setting the internal pressure in equation 2b equal to $724,700 \text{ dyne/cm}^2$ and solving for the radius r_{1a} . The result is 13.1 microns. In Figure 1b, a force, F_{1b} , acting on the piston generates hydraulic pressure arbitrarily assumed to be $100,000 \text{ dyne/cm}^2$ (1.45 psi). The internal pressure is now raised to $824,700 \text{ dyne/cm}^2$ (12.0 psi) and can again be used to calculate the radius of curvature, r_{1b} , of this hydraulically pressurized column from equation (2b). It is 11.5 microns. Thus, the radius of curvature of the free surfaces (i.e., unconstrained corners) at both ends of the mercury column has decreased. It should be noted at this point that since the total pressure within the mercury column is equal at every point, the radius of curvature of every free surface in the column must be identical. Thus, assuming no flow and no pressure drop due to differences in elevation, the radius of all free surfaces will have decreased to 11.5 microns in this example

Figure

Figure

You had not seen including parents up to this point

Referring now to Figure 2, the piston in our hypothetical micro-hydraulic system is made smaller so that it fits into the cylinder with a uniform radial clearance c . This clearance is of such magnitude that in Figure 2a the mercury column has the same appearance as in Figure 1b. Clearly, these two pistons exert the same hydraulic pressure on the column of mercury and no bypass flow will take place in either system until the situation is reached in Figure 2b. At the higher value of hydraulic pressure generated by force F_{2b} in Figure 2b, the mercury will begin to flow around the smaller piston and the system will no longer be leak free. If the clearance is small relative to cylinder diameter, on the order of ten percent or less, the hydraulic pressure needed to cause such bypass flow can be approximated quite well by using its value for the radius in equation 3. Setting this

Values are always numerical

radius to 2 microns and solving for P_{ex} gives 3,623,400 dyne/cm² (52.55 psi). Thus, at any pressure less than this, the system will still be capable of reproducible and repeatable hydraulic activation even though the conditions stated previously that are needed for such activation macroscopically are not rigorously enforced.

The pressure within the column of non-wetting fluid enabling hydraulic activation need not be generated mechanically as has been done thus far. It can also be generated thermally as is illustrated in Figure 3. Here a piston is employed to act as a valve when a heating coil in a pressurizing reservoir is energized. Figure 3a shows the valve open and figure 3b shows it closed. The control-arm capillary branching off the reservoir contains a continuity circuit. When contact is made with the expanding non-wetting fluid, the controller turns off the heating coil preventing over-pressuring. Whenever the fluid is located within the control-arm capillary, the total pressure within the system remains constant, provided the capillary has a constant radius. The radius of the control-arm capillary is determined primarily by two considerations. As before, it must be larger than the piston clearance to prevent bypass flow. In addition, it must be small enough to generate a total pressure within the non-wetting fluid sufficient to keep the piston firmly seated when the valve is closed. This hydraulic-fluid pressure is determined by the pressure of the fluid entering the valve and the diameter of the valve seat. If the valve seat cross-sectional area is smaller than the piston area contacted by hydraulic fluid, a multiplier effect is generated common to all hydraulic systems. In that case, pressure in the hydraulic fluid can be lower than the inlet fluid pressure and still completely stop flow through the valve. It should be noted that the scale of the pressurizing reservoir has been deliberately reduced so that it fits easily into the figure. It must, of course, have a much larger volume than the valve stem so that the relatively small increase in volume of the non-wetting fluid caused by heating will completely fill the valve stem in the closed position.

One shortcoming of such a micro-hydraulic valve is that it is only in the closed position when the heating coil is energized. Even if the control circuitry turns on the coil only intermittently, power would still be consumed at some average rate. This would not be desirable on long-duration applications such as space missions to other planets. In that case, a phase-change technique can be employed using a dual heating coil arrangement and a non-wetting hydraulic fluid that is only liquid at temperatures above those planned for the application. Figure 4 illustrates such a valve. It consists of a "locking" heating coil placed around the enlarged portion of the valve stem in addition to the heating coil in the pressurizing reservoir. The non-wetting hydraulic fluid is now selected from one of the numerous metals or metal alloys which solidify at temperature slightly above ambient for the particular application. Examples are gallium, indium, and tin, and alloys such as the Cerro-bismuth and Cerro-indium series. If both coils are energized as in Figure 4a, the fluid will be fully liquefied and the valve will be closed just as in Figure 3b. If the "locking" heating coil is then turned off, the fluid in the expanded section of the valve stem will solidify firmly holding the piston against the valve stem as in Figure 4b. This will be especially true if one of the Cerro alloys is used since these expand slightly upon solidification. The heating coil in the pressurizing reservoir can then be turned off, conserving power. Before the reservoir solidifies, it would draw still molten non-wetting

it's possible
Cerro
needs TM
after it is
is part of
metal casting
???

A company
out of Chicago?

?

fluid back into itself, ending up looking somewhat like Figure 3a. The plug of solid metal now firmly wedged into the expanded portion of the valve stem would not move, however, and the valve would remain closed. To open the valve, both heating coils would be energized, and then only the pressurizing reservoir coil would be turned off. This is not shown. Turning off the "locking" coil would then keep the valve in the fully open position with no use of power. Figure 5 is a picture of such a valve in the closed position with all power turned off. Again, the scale of the pressurizing reservoir is smaller than actually required.

Rather than use expanding non-wetting fluid to open and close valves, micro-actuation can also easily be arranged. Figure 5 illustrates a constant force double-action micro-actuator. The right-hand pressurizing reservoir heating coil is turned on causing the actuating piston to move to the left. The force that is generated on the piston is simply the total pressure in the non-wetting fluid multiplied by the cross-sectional area of the piston in contact with the fluid. As before, radius of the control-arm capillary determines the total pressure. The same limitations on capillary size also apply. The most important is that the piston clearance as well as actuator arm clearance must be less than control-arm capillary radius to prevent bypass flow. If the heating coil on the right is turned off and the one on the left turned on, motion of the piston will be to the right. If both control-arm capillaries have the same radius, actuating forces in both directions will be equal. Otherwise they will differ.

A positive aspect of using heating coils to achieve pressurization is that it allows controlled motion of the actuating piston, whether it be in a valve or a mechanical actuator. Simply reducing or increasing power sent to heating coils controls the rate of thermal expansion, and therefore piston velocity. This is true only within certain upper limits, however. Instantaneous pressurization cannot take place because of heat transfer limitations. A much more rapid pressurization device is illustrated in Figure 6. It is a hybrid device that uses a solenoid as well as multiple control-arm capillaries. The control-arm capillaries do not need continuity and control circuitry when used in this fashion, however. Their function now is to passively control non-wetting fluid pressure using equation 3, as before, but also to ~~now~~ act as a storage location for the pressurized fluid. In Figure 6a, the solenoid has not been activated and non-wetting fluid is not contained within any of the multiple control-arm capillaries. Total pressure within the hydraulic fluid is very low because of the relatively large diameter of the pressurizing reservoir. In Figure 6b, the solenoid has been turned on causing very rapid filling of the control-arm capillaries. This instantaneously increases the total pressure within the non-wetting fluid shutting the valve. Of course, the solenoid plunger itself could be used to shut the valve. However, this might not be possible or desirable in some applications, such as ~~on~~ on a micro-chip, for example. In a remote setup, the transfer line, which can be fabricated to close tolerances by microtube technology (5), could have virtually any length and configuration which greatly expands the design possibilities. This is, after all, one of the primary benefits of hydraulic systems.

In both kinds of micro-valves actuated by non-wetting pressurized fluids, there is ample opportunity for contact to take place between the hydraulic fluid and the fluid being

controlled because of piston clearance. This may or may not be a problem depending on the particular chemical nature of the fluids involved. However, it must certainly be taken into consideration in the design phase. Only if both fluids are non-wetting might contact not take place.

While the discussion up to this point has all centered around circular capillaries, which can be manufactured using microtube technology (5), equivalent arguments can be made for capillaries, or micro-channels, having non-circular cross-sections as well, which can also be manufactured by the same technique. A square piston in a square micro-channel having a uniform clearance on all sides would behave virtually identically to its circular analog. Moreover, such square or rectangular cross-sections are much more easily fabricated using conventional MEMS techniques, such as photolithography or LIGA, than circular profiles. Micro-hydraulic actuation using non-wetting fluids is therefore also applicable in these situations as well.

Another feature of micro-hydraulic systems based on non-wetting fluids is the ability to "float" surfaces away from one another reducing friction. Figure 7 illustrates two devices that perform this feat. In Figure 7a, a rotary-translational micro-bearing is fitted around a center shaft. The outer race consists of a collar, both ends of which have some small amount of clearance with the center shaft. The inside of the collar has been removed leaving an annular gap within the collar much larger than the clearance at either end. Non-wetting fluid has then been injected into this gap filling it to the point where bypass flow is becoming imminent. This will, of course, require some insertion pressure, P_i , just as before and can be calculated from equation 3. Because the non-wetting fluid completely surrounds the center shaft, this insertion pressure will push it uniformly away from the outer race in all radial directions causing it to "float". The center shaft can now rotate or translate freely without contacting the outer race, which can then be mounted to some other fixed surface. In Figure 7b, a rotary-thrust micro-bearing is illustrated. The center shaft can now rotate, but not translate. In either type of micro-bearing, filling of the annular gaps could be accomplished through a side port on the race.

In summary, the use of non-wetting fluids in micro-hydraulic applications has many benefits. The existence of clearances between sliding surfaces does not prevent hydraulic actuation if proper design protocols are adhered to. Capillaries having non-circular cross-sections, or micro-channels, can be used which allows conventional MEMS fabrication techniques to be employed. Many types of pressurization techniques are possible including mechanical, thermal, and electrical. Precise control of hydraulic pressure is assured since surface tension and wettability are the controlling variables in micro-channels. And, the non-wetting fluid itself has the ability to function as a bearing separating moving surfaces and thereby minimizing friction.

REFERENCES

1. P.G. Wapner and W.P. Hoffman, Submitted to Sensors and Actuators

← has this been accepted? If not & you want to use it, it would be better to footnote. If you can't do that provide a way the readers can obtain it (through author?)

2. T. Young, *Trans. R. Soc. London* **95**, 65 (1805)
3. P. S. de Laplace, *Mechanique Celeste*, Supplement to Book 10. (1806)
4. A.W. Adamson, *Physical Chemistry of Surfaces*, Wiley, NY, 1976 pp. 9-10
5. W. P Hoffman, H.T. Phan, and P. G. Wapner, *Mat. Res. Innovat.* **2**, 87 (1998)

are these dates???

Usually book titles are bold or underlined, not italic (italic represents mags or journals)

page #s.

Normally, authors are listed by last name, first initial (at least the first author)

Books need publisher & publisher's city/state, date, (pg. numbers pref.)

Journal/magazines need pg.#s.

FIGURE 1

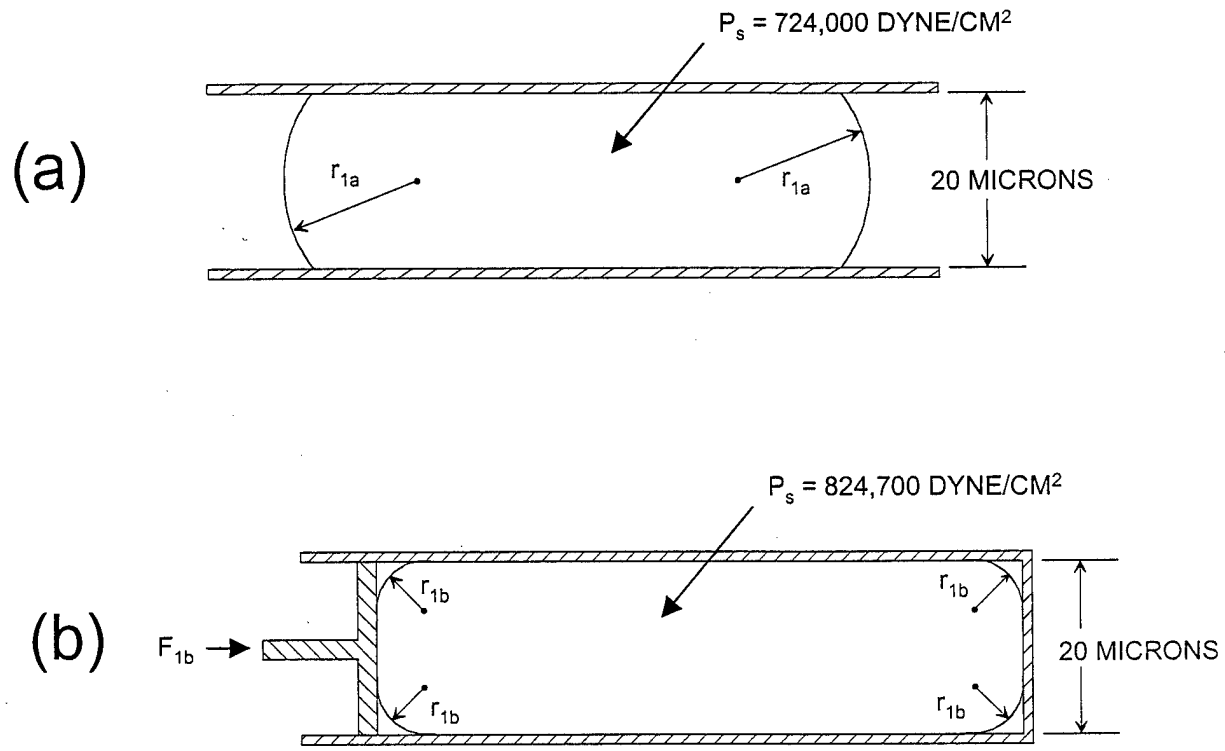

FIGURE 2

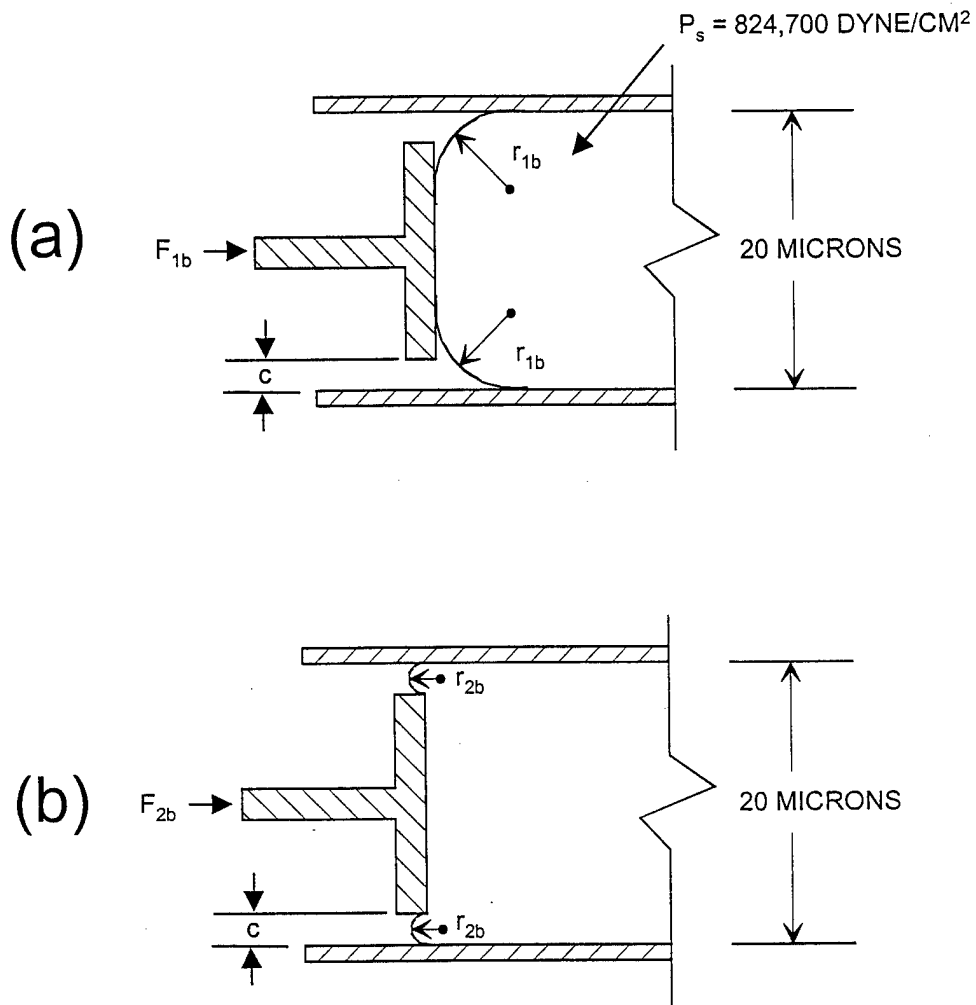

FIGURE 3

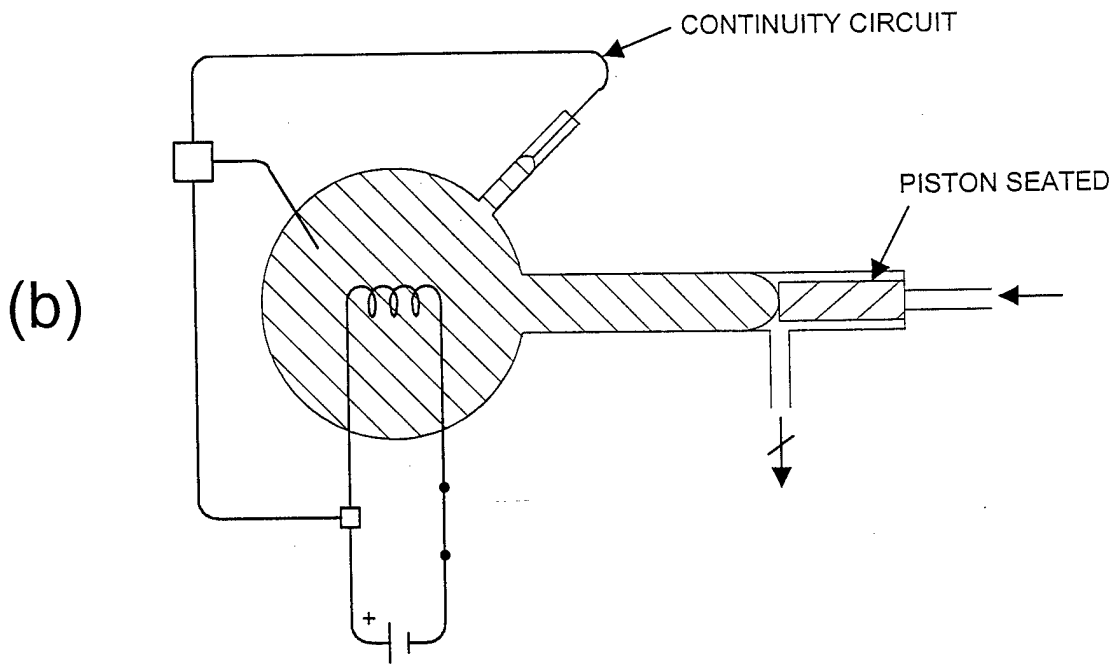
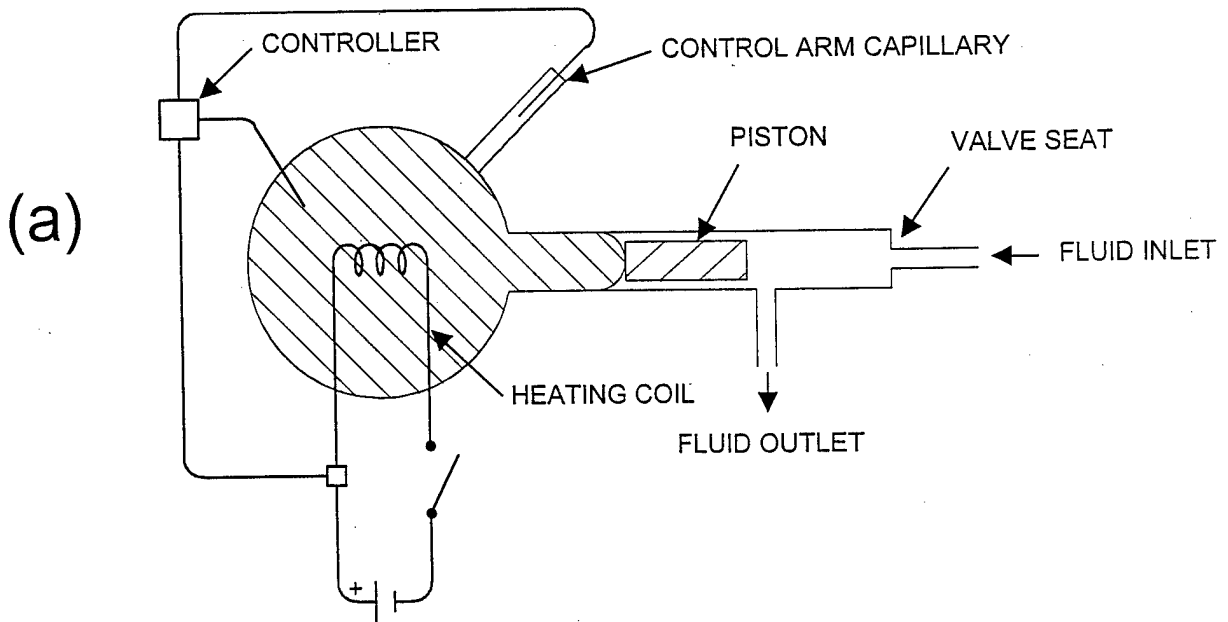

FIGURE 4

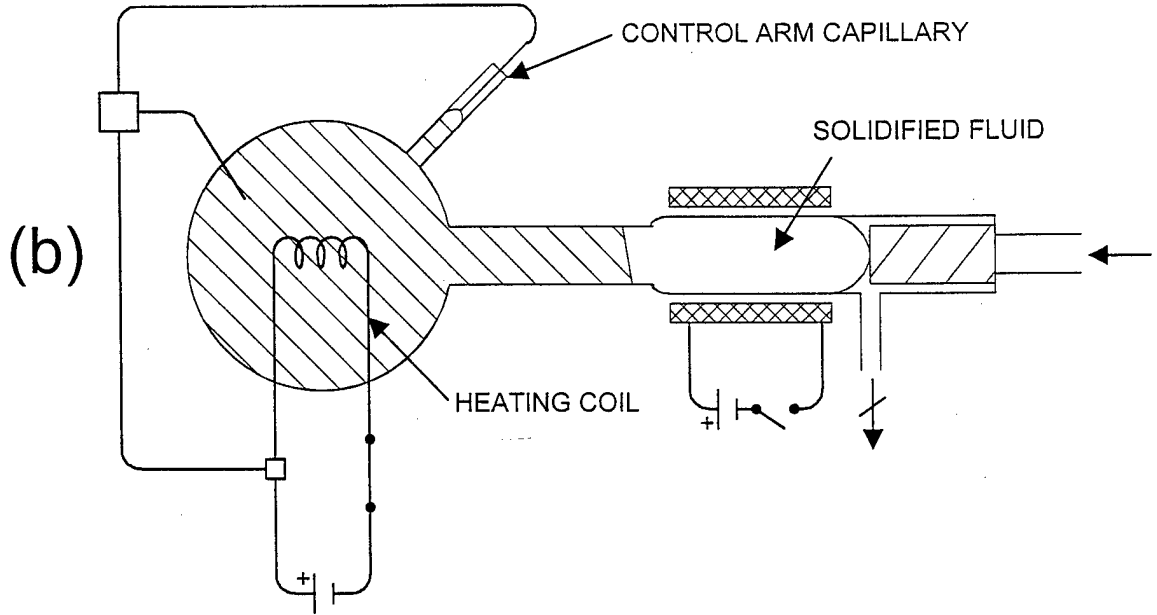
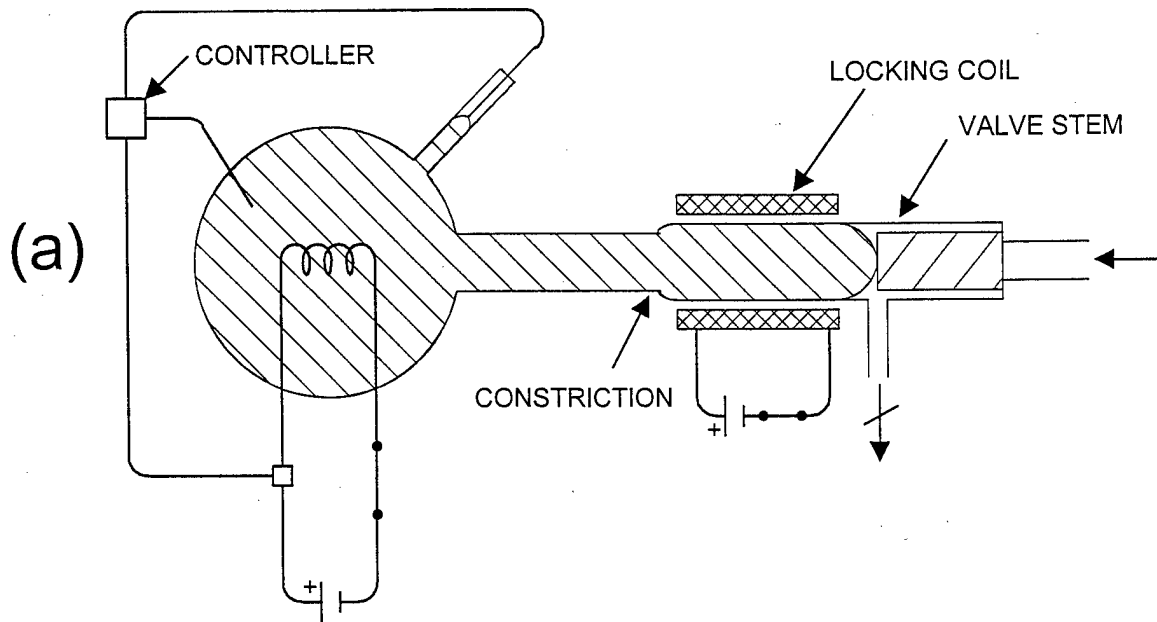

FIGURE 5

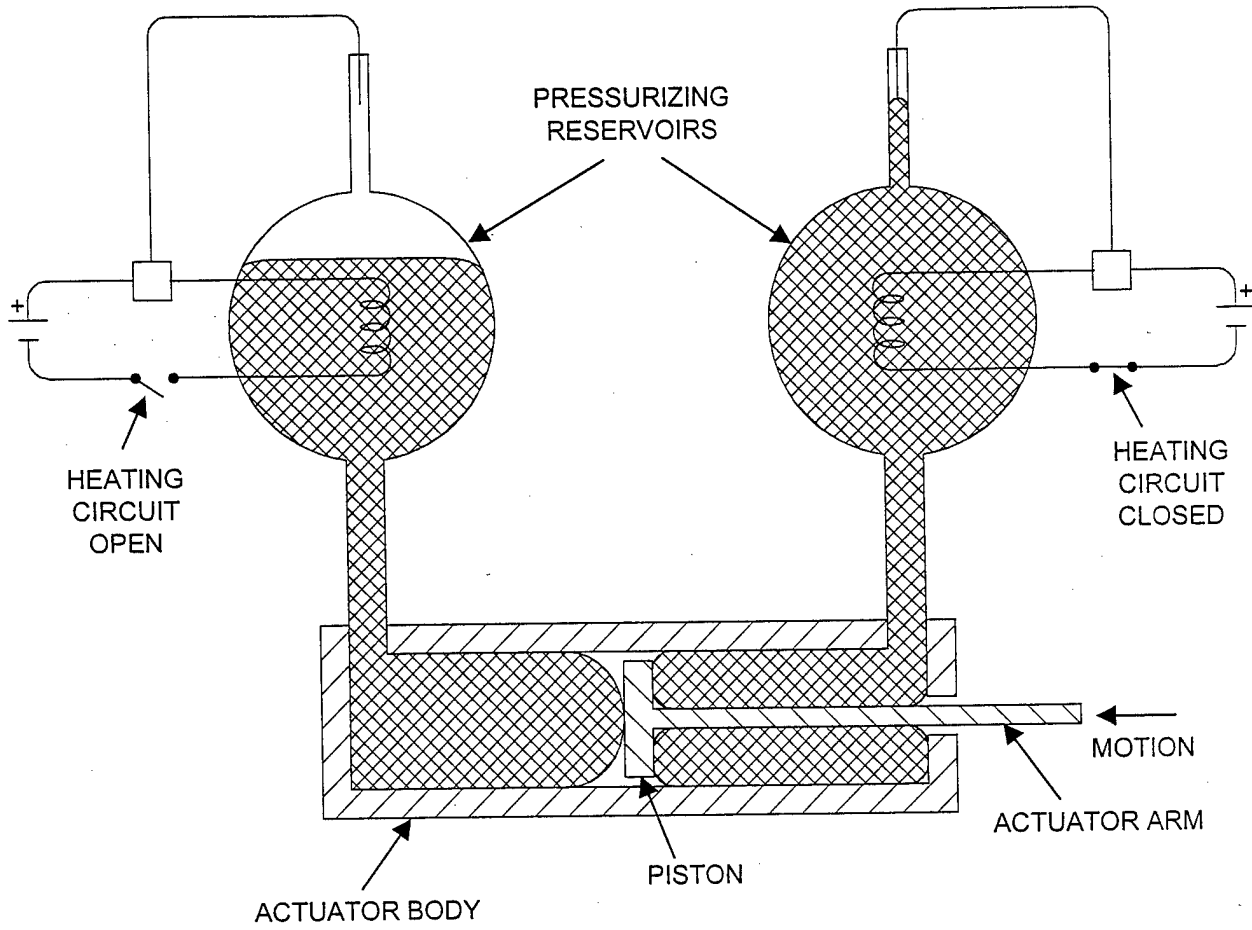

FIGURE 6

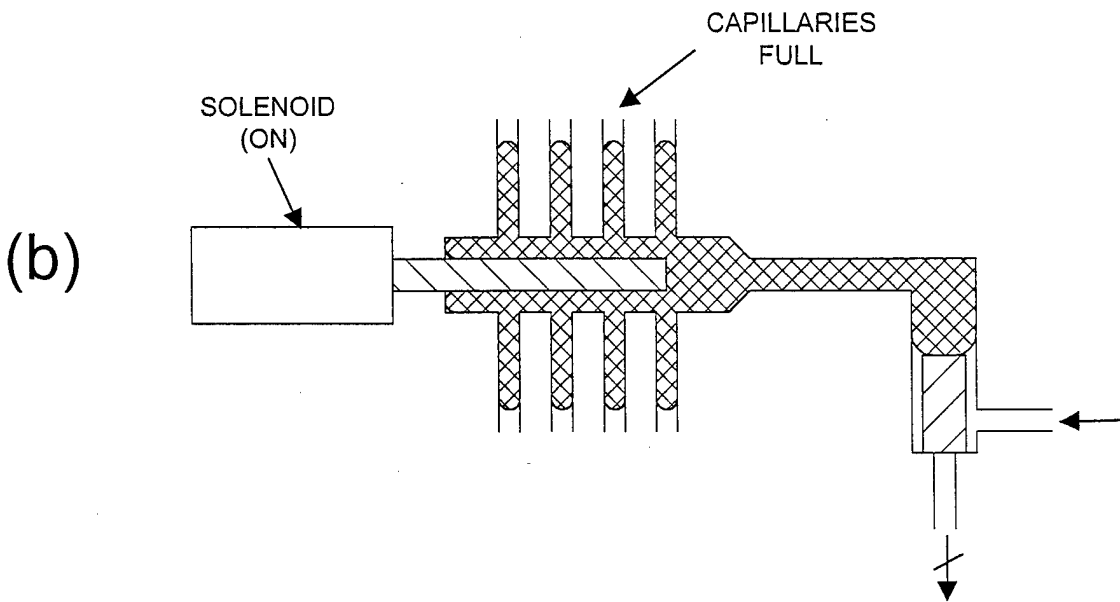
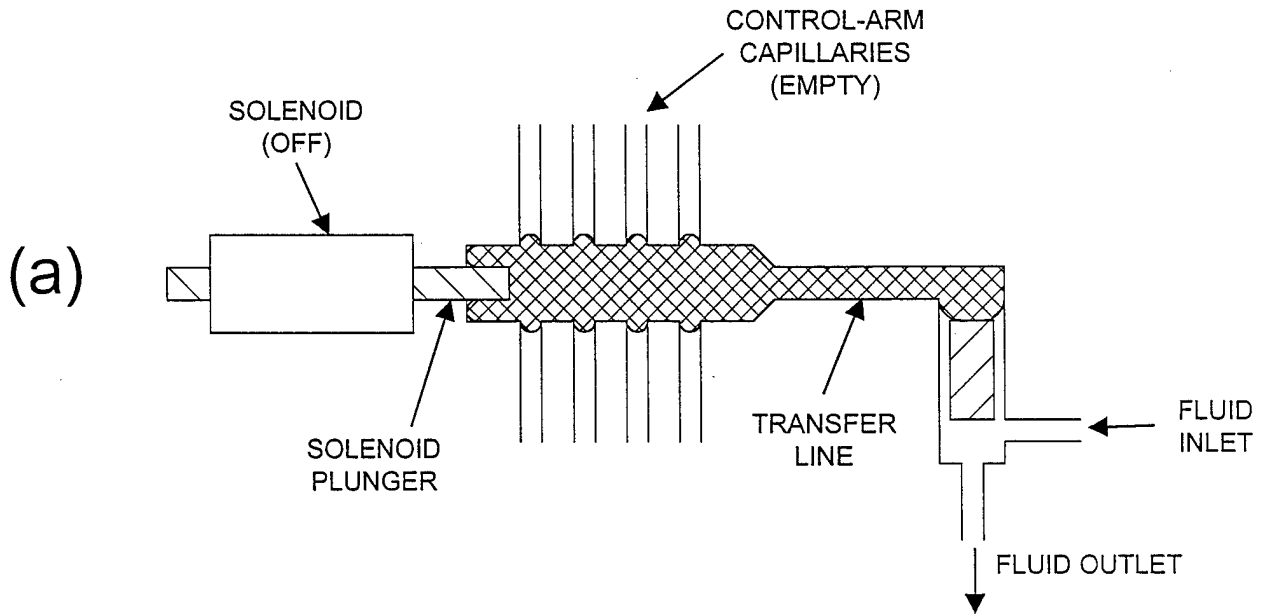
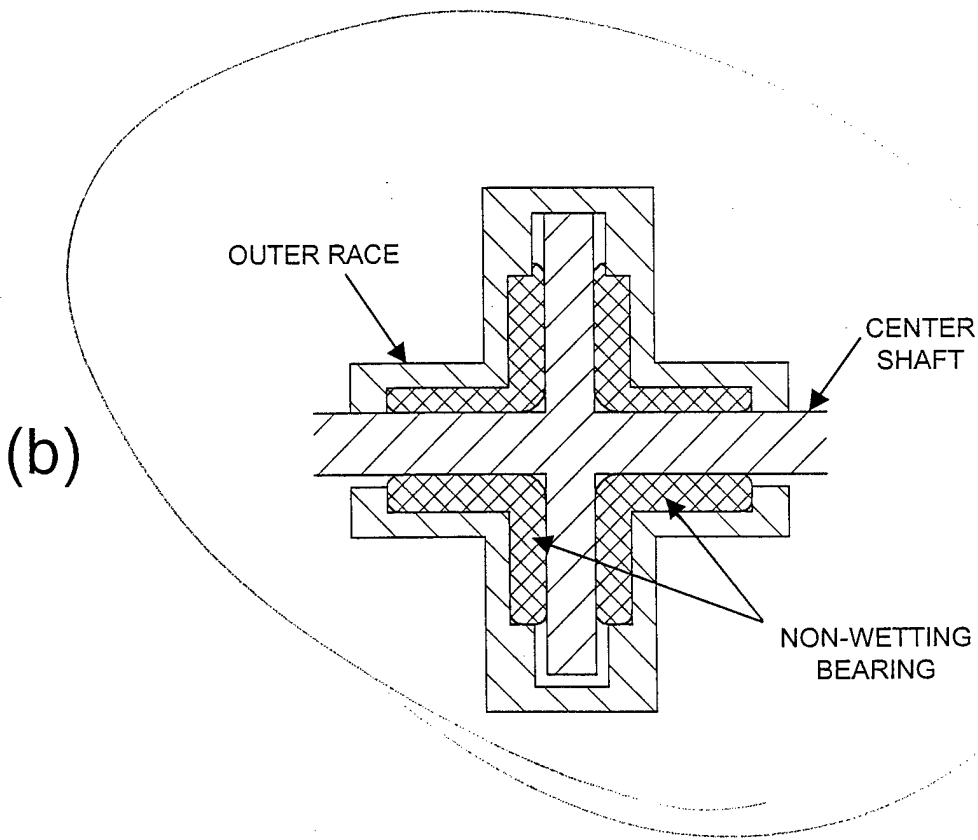
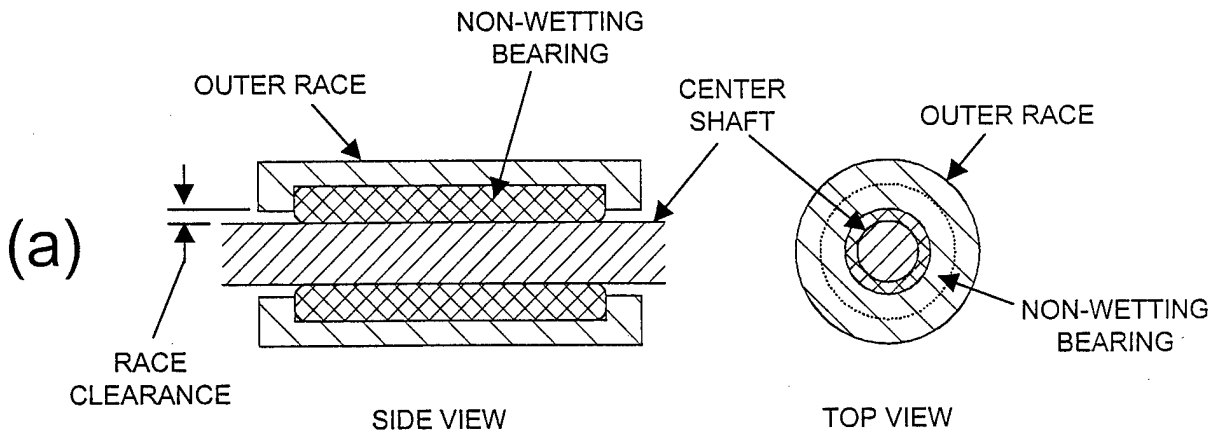

FIGURE 7



TO BE
REVISED
QAR