

AD \_\_\_\_\_

Award Number: DAMD17-00-1-0279

TITLE: Kinase Independent Functions of Cyclin D1 Which  
Contribute to its Oncogenic Potential In Vivo

PRINCIPAL INVESTIGATOR: Mark W. Landis  
Philip W. Hinds, Ph.D.

CONTRACTING ORGANIZATION: Harvard Medical School  
Boston, Massachusetts 02115

REPORT DATE: July 2002

TYPE OF REPORT: Annual Summary

PREPARED FOR: U.S. Army Medical Research and Materiel Command  
Fort Detrick, Maryland 21702-5012

DISTRIBUTION STATEMENT: Approved for Public Release;  
Distribution Unlimited

The views, opinions and/or findings contained in this report are those of the author(s) and should not be construed as an official Department of the Army position, policy or decision unless so designated by other documentation.

20021129 042

# REPORT DOCUMENTATION PAGE

Form Approved  
OMB No. 074-0188

Public reporting burden for this collection of information is estimated to average 1 hour per response, including the time for reviewing instructions, searching existing data sources, gathering and maintaining the data needed, and completing and reviewing this collection of information. Send comments regarding this burden estimate or any other aspect of this collection of information, including suggestions for reducing this burden to Washington Headquarters Services, Directorate for Information Operations and Reports, 1215 Jefferson Davis Highway, Suite 1204, Arlington, VA 22202-4302, and to the Office of Management and Budget, Paperwork Reduction Project (0704-0188), Washington, DC 20503

1. AGENCY USE ONLY (Leave blank)	2. REPORT DATE July 2002	3. REPORT TYPE AND DATES COVERED Annual Summary (1 Jul 01 - 30 Jun 02)
----------------------------------	-----------------------------	---------------------------------------------------------------------------

4. TITLE AND SUBTITLE Kinase Independent Functions of Cyclin D1 Which Contribute to its Oncogenic Potential In Vivo	5. FUNDING NUMBERS DAMD17-00-1-0279
------------------------------------------------------------------------------------------------------------------------	----------------------------------------

6. AUTHOR(S)  
Mark W. Landis  
Philip W. Hinds, Ph.D.

7. PERFORMING ORGANIZATION NAME(S) AND ADDRESS(ES)  
Harvard Medical School  
Boston, Massachusetts 02115  
  
E-Mail: mlandis@fas.harvard.edu

8. PERFORMING ORGANIZATION REPORT NUMBER

9. SPONSORING / MONITORING AGENCY NAME(S) AND ADDRESS(ES)  
U.S. Army Medical Research and Materiel Command  
Fort Detrick, Maryland 21702-5012

10. SPONSORING / MONITORING AGENCY REPORT NUMBER

11. SUPPLEMENTARY NOTES

12a. DISTRIBUTION / AVAILABILITY STATEMENT  
Approved for Public Release; Distribution Unlimited

12b. DISTRIBUTION CODE

13. Abstract (Maximum 200 Words) (abstract should contain no proprietary or confidential information)  
Cyclin D1, an important cell cycle regulator, is a potent oncogene in several tumor types, including breast cancer. The most well understood function of cyclin D1 is to bind and activate cdk4 and 6. One target of these kinases is pRb. Upon phosphorylation, pRb is inactivated, and cells pass from G1 into S phase. We and others have demonstrated that cyclin D1 has other functions, many of which are independent of kinase activity *in vitro*. *In vivo* demonstration of kinase independent functions of cyclin D1 may help elucidate the underlying mechanisms of cyclin D1 oncogenicity.  
To determine whether cyclin D1 has important kinase-independent functions *in vivo*, we are generating a cyclin D1 K112E knock-in mouse. This single base change results in a cyclin that can bind to, but not activate the kinase partner. As the locus will be left almost undisturbed, we expect that the mutant allele will be expressed in a normal manner. The phenotype of the mouse will be analyzed to determine whether any of the phenotypes of the cyclin D1 *-/-* mouse are rescued. This analysis will allow dissection of how the kinase-independent functions of cyclin D1 contribute to development, proliferation and oncogenesis *in vivo*.

14. SUBJECT TERMS  
cell cycle, cyclin, development, animal model, proliferation control, oncogene, tumor suppressor, knock-in mouse, breast cancer

15. NUMBER OF PAGES  
12

16. PRICE CODE

17. SECURITY CLASSIFICATION OF REPORT  
Unclassified

18. SECURITY CLASSIFICATION OF THIS PAGE  
Unclassified

19. SECURITY CLASSIFICATION OF ABSTRACT  
Unclassified

20. LIMITATION OF ABSTRACT  
Unlimited

## Table of Contents

Cover.....	1
SF 298.....	2
Table of Contents.....	3
Introduction.....	4
Body.....	4
Key Research Accomplishments.....	5
Reportable Outcomes.....	5
Conclusions.....	6
References.....	6
Appendices.....	7-12

## Introduction

Cyclin D1, an important cell cycle regulator, is a potent oncogene in several tumor types, including breast cancer. The most well understood function of cyclin D1 is to bind and activate cyclin dependent kinases (cdks) 4 and 6. One target of these kinases is pRb. Upon phosphorylation, pRb is inactivated, and cells pass from G1 into S phase. We and others have demonstrated that cyclin D1 has other functions, many of which are independent of kinase activity *in vitro*. *In vivo* demonstration of kinase independent functions of cyclin D1 may help elucidate the underlying mechanisms of cyclin D1 oncogenicity.

To determine whether cyclin D1 has important kinase-independent functions *in vivo*, we are generating a cyclin D1 K112E knock-in mouse. This single base change results in a cyclin that can bind to, but not activate the kinase partner. As the locus will be left almost undisturbed, we expect that the mutant allele will be expressed in a normal manner. The phenotype of the mouse will be analyzed to determine whether any of the phenotypes of the cyclin D1  $-/-$  mouse are rescued. This analysis will allow dissection of how the kinase-independent functions of cyclin D1 contribute to development, proliferation and oncogenesis *in vivo*.

## Body

To determine which functions of cyclin D1 are important *in vivo*, we have undertaken the generation of a knock-in mouse. Mouse embryonic stem cells were targeted for homologous recombination with the targeting construct shown (figure 1). Following selection, ES clones were screened for homologous recombination. Several clones screened positive in Southern Blot, PCR, and karyotyping. Three clones have now been injected into blastocysts. Of these, the first has been transmitted into the germ-line, the other two are currently in progress.

From the first injection, three male and one female chimeras were obtained. Two of the males produced a total of seven agouti offspring, indicating germ line transmission of the ES cells. Of the seven offspring, three males screened positive for the KE allele by PCR (figure 2). These males were then crossed to wild-type animals to generate female animals carrying the allele. Due to technical concerns about treating ES cells with CRE, we opted to remove the flox-neo drug cassette by mating heterozygote animals to transgenic animals carrying the CRE recombinase under control of the nestin promoter (nestin-cre). Progeny of these crosses were screened by PCR for the presence of the KE allele and absence of the flox-neo cassette. These progeny were found and crossed together to generate homozygous KE/KE animals (figure 3). To ensure that these animals carried the desired allele, the PCR product was subcloned and several clones were sequenced. As shown, the wild type animal carries a lysine residue at position 112, whereas the knock-in animals have a glutamate residue at this position.

D1  $-/-$  animals are substantially smaller than their wild-type littermates. To determine whether this is also the case for KE/KE animals, we weighed litters of progeny generated from crosses of KE/+ animals. The KE/KE animals are substantially smaller than the wild-type littermates (figure 4A); however, they are probably not quite as small as the D1  $-/-$  animals. We are currently back-crossing the KE allele into the same strain background as the D1  $-/-$  so that we can make a direct comparison. A second phenotype of the D1  $-/-$  animal is a 'claspings' reflex: when the mouse is lifted by the tail, it brings its rear legs together rather than splaying them as the wild-type mouse does. As shown, the KE/KE mouse also exhibits this claspings phenotype when lifted (figure 4B).

In addition to the D1  $-/-$  animal's size deficiency, two tissues in this mouse are profoundly affected by the absence of cyclin D1. The retinas of the knockout are severely hypoplastic, developing only a few layers of cells. In addition, the mammary glands of the knockout are deficient in

proliferation in response to the hormonal signals of pregnancy. Eyes from KE animals and their wild-type littermates were dissected and fixed in Bouin's. Eyes were embedded, sliced, and stained with H&E. The KE sections were examined and exhibited only a mild defect, with the cell layers being slightly thinner than the wild-type layers (figure 5). KE females were mated and at day 1 post-partum were sacrificed. Mammary glands were dissected and whole-mount staining performed. Analysis of the mammary glands revealed relatively normal development of the mammary epithelium compared to wild-type (figure 5).

To examine the biochemical properties of the KE protein, lysates were made from E. 14.5 embryos. To compare levels of various cell cycle regulators, a Western Blot analysis was done. Levels of cyclin D1, D2, D3, p27, CDK4, CDK6 and pRb were equivalent in the KE animal and the wild-type littermate (figure 6). Mouse cyclin D1 runs as a doublet, and interestingly the relative abundance of the fast vs. slow migrating form is changed in the KE animal, with the faster migrating form being more abundant. We intend to attempt to determine whether these forms are differentially phosphorylated.

To determine the ability of the KE protein to bind to its kinase partner, IPs were performed. Either cyclin D1 or CDK4 was immunoprecipitated from embryo lysates and the material subjected to PAGE. The resulting Western Blots were probed for cyclin D1, CDK4 or p27 (figure 7). Interestingly, not as much KE came down in the IP as did wild-type D1. This presents a technical issue, as measuring the activity of cyclin D1 and KE depends on the ability to IP equivalent amounts of protein from the lysates. It will be necessary to test a panel of anti-D1 antibodies to try to obtain one that will both IP equivalent amounts of protein and support kinase activity. In the CDK4 IP, it appears that a slightly lower amount of KE binds to CDK4 than wild-type D1. However, the total amount of p27 bound to CDK4 is equivalent. This is important because p27 is capable of redistributing away from CDK4 complexes to cyclin E/CDK2 complexes and inhibiting them. To test whether p27 pools were mobilizing and changing the activity of CDK2, a CDK2 IP-kinase assay was performed (figure 8). CDK2 complexes were immunoprecipitated from lysates and used to phosphorylate histone H1 in an in vitro kinase assay. Activity was variable in this experiment, and shows no consistent decrease in KE animals.

Although we are well into the process of analyzing whole embryo lysates, it is also necessary to analyze the biochemistry in the mammary gland and retina as these tissues depend critically on the presence of cyclin D1. We are in the process of collecting enough tissue to enable study of the biochemistry in these tissues. It is extremely important that we are able to quantitatively assess the level of activity possessed by KE/CDK complexes in these tissues and determine whether they are able to develop due to kinase independent functions of cyclin D1. This will depend on finding an appropriate antibody.

### **Key Research Accomplishments**

- Generation of mice homozygous for the cyclin D1 K112E allele
- Characterization of the phenotype of this animal including: size, retinal development, mammary gland development
- Biochemical characterization of this animal including: KE protein expression, KE complex formation, and CDK2 activity

### **Reportable Outcomes**

- Generation of homozygous animals carrying two copies of the K112E allele
- Abstract presented at the Cold Spring Harbor "Cell Cycle" conference

## Conclusions

Homozygous mice carrying two alleles of cyclin D1 K112E have been generated. We have been characterizing the phenotype of these animals and comparing them to the wild-type and cyclin D1 knockout animals. The KE animals are smaller than the wild-type animals and clasp their rear legs when lifted. However, the defects in the retina and mammary gland of the KE animal are quite mild compared to the severity of these deficiencies in the knockout.

To analyze the mechanisms at work in these animals we have begun to investigate the biochemistry and molecular biology in these tissues. Cyclin D1 KE is expressed in the knock-in mouse at an approximately equivalent level as in the wild-type mouse. It appears that KE may not bind to CDK4 as robustly as wild-type cyclin D1; however, this does not result in p27 shifting to cyclin E complexes. Indeed, CDK2 activity is similar in KE and wild-type tissues.

We are undertaking the careful characterization of this biochemistry in tissues that are profoundly affected in the D1  $-/-$  animal, namely the retina and mammary gland. Our study in the mammary gland should shed light on the molecular mechanisms underlying development of the mammary epithelium in response to pregnancy. This may also be applicable to the development of breast cancer.

As noted in the previous annual report, the absence of cyclin D1 can completely protect mice against some induced breast cancers (1). We intend to use the KE mouse we have generated during this project to test whether cyclin D1 associated kinase activity is necessary for mammary tumorigenesis or whether the oncogenic properties of cyclin D1 in the breast are due to some other mechanism. In the future the KE mouse will be mated to the MMTV-neu mouse and tumor susceptibility studied. This study should shed light on the value of cyclin D1 dependent kinase activity as a therapeutic target in breast cancer.

## References

1. Yu Q. Geng Y. Sicinski P. (2001). Specific protection against breast cancers by cyclin D1 ablation. *Nature*. 411(6841):1017-21.

# Mouse Cyclin D1 K112E Knock-In

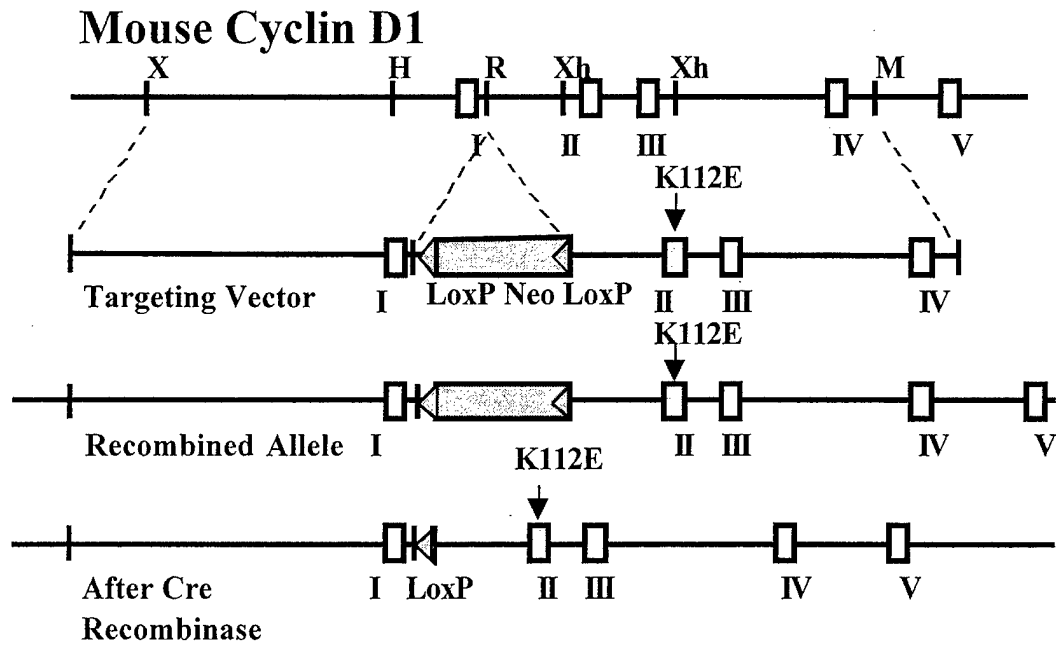

Figure 1. The targeting cassette used to generate ES cells contains a floxed-neo gene used for selection and a single base change that will generate the K112E mutation. After recombination and treatment with the Cre recombinase, the locus will be left virtually undisturbed

**PCR of 3 F1 Progeny of KE Chimeric Males  
Demonstrates Germ-Line Transmission of the Allele**

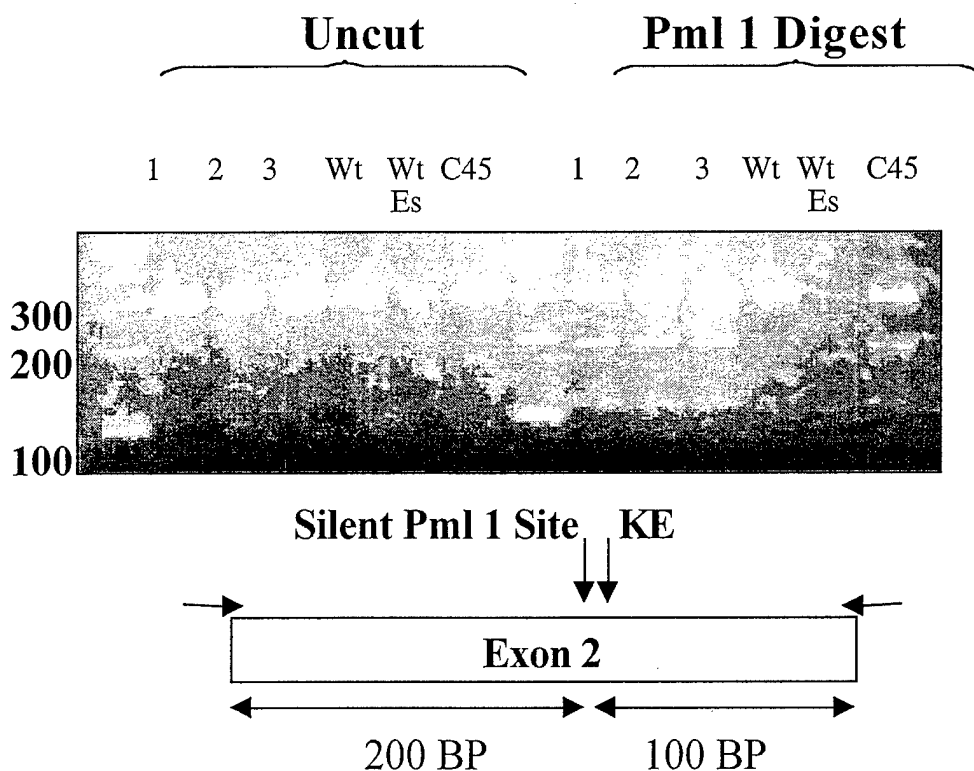

Figure 2. DNA from agouti progeny of the chimeric animals was subjected to PCR to determine whether the animals were transgenic for the desired allele. A silent Pml1 site was built in to the targeting cassette. PCR across the region yields a 300 bp fragment that when digested gives a 200 and 100 bp fragment indicative of the knock-in allele. Agouti progeny 1-3 and C45 (the original ES clone used to generate the chimeras) all demonstrate the knock-in allele, whereas a wild-type (Wt) mouse and wild-type ES cells do not show these bands when digested with Pml1.



## The KE Mouse Exhibits the 'Clasping' Phenotype and is Smaller than its Wild-Type Counterpart

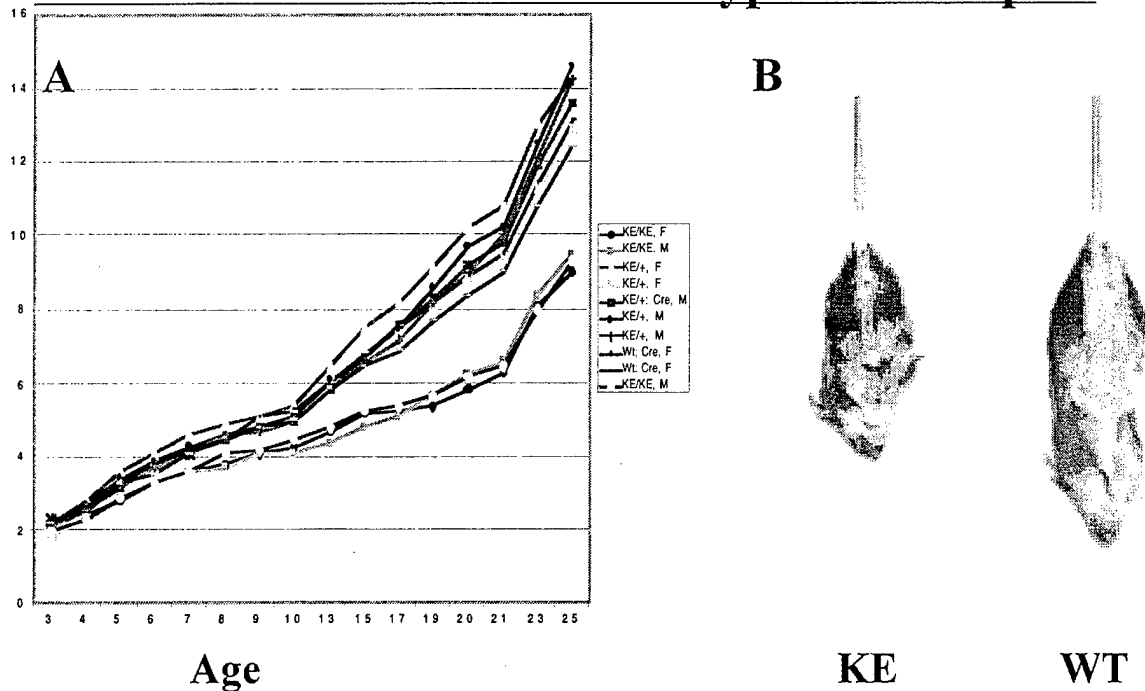

Figure 4. (A) A litter generated from heterozygous parents was weighed periodically over the first 25 days of life. KE/KE animals are substantially smaller than Wt/Wt or Wt/KE littermates. (B) When lifted by the tail, the normal response of the mouse is to spread its rear legs. The cyclin D1 KE mouse exhibits an abnormal 'clasping' phenotype similar to the cyclin D1 knockout mouse (not shown).

## Retinas and Mammary Glands From KE/KE Animals Show Only Subtle Developmental Defects

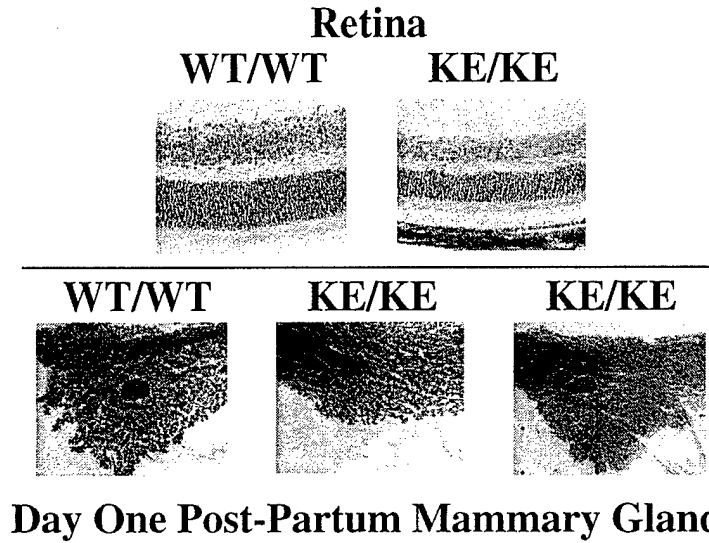

Figure 5. H & E staining of retinas from wild-type and KE mice show only subtle defects in organization and thickness. The wild-type section is cut at an angle resulting in the appearance of extra layers. Mammary glands were dissected from one day post-partum mothers, whole mounted and stained. The mammary glands from KE mice appear to develop in a relatively normal manner.

### Levels Of Cell Cycle Regulators In WT And KE E 14.5 Littermates

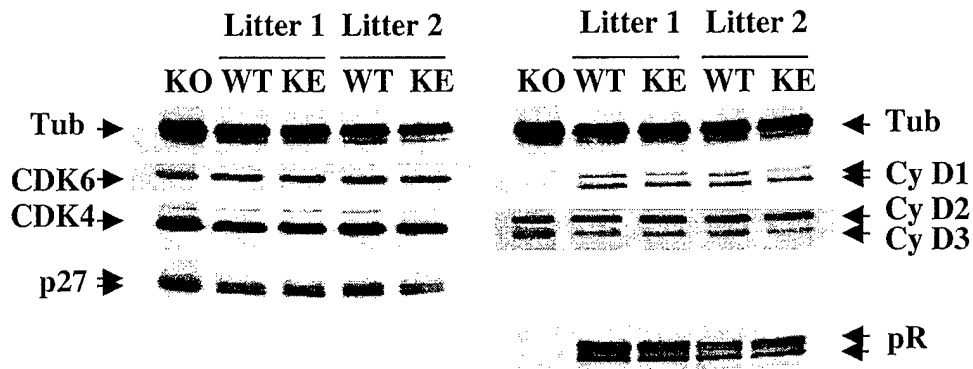

Figure 6. Levels of various cell cycle regulators were assessed by Western Blot analysis. Protein lysates were made from two pairs of wild-type and knock-in littermates. Levels of the different cell cycle regulators are equivalent in the wild-type and knock-in mice.

**Binding of CDK 4 to Cyclin D1 and KE**

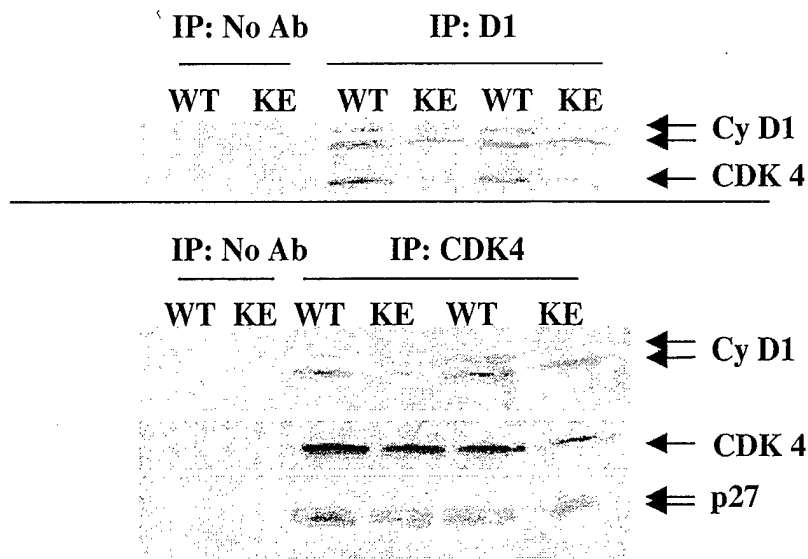

Figure 7. Proteins were immunoprecipitated from lysates with either D1 or CDK4 antibodies. Western blots were then probed for D1, CDK4 or p27.

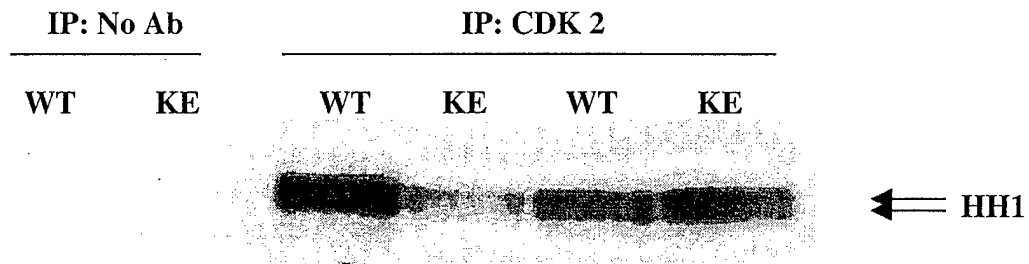

Figure 8. CDK2 complexes were immunoprecipitated from lysates and used to phosphorylate histone H1 in an in vitro kinase reaction.