

**DEFENSE TECHNICAL INFORMATION CENTER
REQUEST FOR SCIENTIFIC AND TECHNICAL REPORTS**

Title

UNMANNED HYBRID VEHICLE Vol 4

1. Report Availability (Please check one box)

- This report is available. Complete sections 2a - 2f.
 This report is not available. Complete section 3.

2a. Number of
Copies Forwarded

2b. Forwarding Date

2c. Distribution Statement (Please check ONE box)

DoD Directive 5230.24, "Distribution Statements on Technical Documents," 18 Mar 87, contains seven distribution statements, as described briefly below. Technical documents MUST be assigned a distribution statement.

- DISTRIBUTION STATEMENT A: Approved for public release. Distribution is unlimited.
- DISTRIBUTION STATEMENT B: Distribution authorized to U.S. Government Agencies only.
- DISTRIBUTION STATEMENT C: Distribution authorized to U.S. Government Agencies and their contractors.
- DISTRIBUTION STATEMENT D: Distribution authorized to U.S. Department of Defense (DoD) and U.S DoD contractors only.
- DISTRIBUTION STATEMENT E: Distribution authorized to U.S. Department of Defense (DoD) components only.
- DISTRIBUTION STATEMENT F: Further dissemination only as directed by the controlling DoD office indicated below or by higher authority.
- DISTRIBUTION STATEMENT X: Distribution authorized to U.S. Government agencies and private individuals or enterprises eligible to obtain export-controlled technical data in accordance with DoD Directive 5230.25, Withholding of Unclassified Technical Data from Public Disclosure, 6 Nov 84.

2d. Reason For the Above Distribution Statement (in accordance with DoD Directive 5230.24)

2e. Controlling Office

2f. Date of Distribution Statement
Determination

3. This report is NOT forwarded for the following reasons. (Please check appropriate box)

- It was previously forwarded to DTIC on (date) and the AD number is
- It will be published at a later date. Enter approximate date if known.
- In accordance with the provisions of DoD Directive 3200.12, the requested document is not supplied because:

Print or Type Name

ROBERT A. Frederick, Jr.

Signature

Robert A. Frederick, Jr.

Telephone

256-824-7203

(For DTIC Use Only)

AQ Number 403-01-0024

REPORT DOCUMENTATION PAGE

Form Approved
OMB No. 0704-0188

Public reporting burden for this collection of information is estimated to average 1 hour per response, including the time for reviewing instructions, searching existing data sources, gathering and maintaining the data needed, and completing and reviewing the collection of information. Send comments regarding this burden estimate or any other aspect of this collection of information, including suggestions for reducing this burden, to Washington Headquarters Services, Directorate for Information Operations and Reports, 1215 Jefferson Davis Highway, Suite 1204, Arlington, VA 22202-4302, and to the Office of Management and Budget, Paperwork Reduction Project (0704-0188), Washington, DC 20503.

1. AGENCY USE ONLY (Leave blank)		2. REPORT DATE September 27, 2002	3. REPORT TYPE AND DATES COVERED Final Report Volume IV	
7. TITLE AND SUBTITLE Unmanned Hybrid Vehicle - Volume IVI (of four)			5. FUNDING NUMBERS	
6. AUTHORS Jennifer C. Pierce, Dana M. Quick, Geof F. Morris, and Robert A. Frederick, Jr.			DAAH01-01-C-R160 SLINs 0003AQ, 0004AG, 0006AK, 0006AL, Mod. 25	
19. PERFORMING ORGANIZATION NAME(S) AND ADDRESS(ES) University of Alabama in Huntsville 301 Sparkman Drive Huntsville, AL 35899			20. PERFORMING ORGANIZATION REPORT NUMBER N/A	
21. SPONSORING/MONITORING AGENCY NAME(S) AND ADDRESS(ES) U.S. Army AMCOM			22. SPONSORING/MONITORING AGENCY REPORT NUMBER	
11. SUPPLEMENTARY NOTES Volume IV of a four-volume Final Report				
12a. DISTRIBUTION/AVAILABILITY STATEMENT DISTRIBUTION STATEMENT A Approved for Public Release Distribution Unlimited			12b. DISTRIBUTION CODE	
13. ABSTRACT (Maximum 200 words) Aviation and ground systems must increase use of emerging and advanced technologies to remain viable in complex, future battlefield environments. Unmanned vehicles will become part of future military operations due to: the demand for immediate intelligence on the battlefield, decreasing defense budgets, increasing operational tempos, and the low tolerance for casualties by the public. This work develops and evaluates system level concepts that fulfill these overall requirements using an unmanned hybrid vehicle. The unmanned hybrid vehicle combines the attributes of an autonomous vertical takeoff and landing air vehicle and an autonomous ground vehicle. This allows fast, flexible deployment and quiet, longer duration ground missions. The assumed time of deployment is the year 2012. The study included requirements definition, concept synthesis, and down selection to three final configurations. Engineering students from the University of Alabama in Huntsville and Ecole Supérieure des Techniques Aéronautiques et de Construction Automobile participated on three competing design teams. Team 1 developed a basic system with coaxial rotors and a fuel cell drive system. The system is one unit that can both fly and operate on the ground. Team 2 developed a separate air and ground vehicle with intermeshing rotors. The integrated ground unit is deployed and retrieved by the air system. Team 3 also developed a separate air and ground vehicle but with a single rotor system that also requires a tail rotor.				
14. SUBJECT TERMS Unmanned Aerial Vehicle, Unmanned Ground Vehicle, robotics, autonomous flight, helicopter			15. NUMBER OF PAGES 98	
			16. PRICE CODE	
17. SECURITY CLASSIFICATION OF REPORT UNCLASSIFIED	18. SECURITY CLASSIFICATION OF THIS PAGE UNCLASSIFIED	19. SECURITY CLASSIFICATION OF ABSTRACT UNCLASSIFIED	20. LIMITATION OF ABSTRACT UL	

NSN 7540-01-280-5500

Computer Generated

STANDARD FORM 298 (Rev 2-89)

Prescribed by ANSI Std Z39-18

298-102

20021107 021

Unmanned Hybrid Vehicle

Final Report – Volume IV IPT 3

Submitted By:

UAH Integrated Product Team 2002



**Authors: Jennifer C. Pierce, Dana M. Quick, Geof F. Morris, & Robert A. Frederick,
Jr**

Contract DAAH01-01-C-R160 Option Order 25

Principal Investigator
Robert A. Frederick, Jr.
Associate Professor
Technology Hall S231
Department of Mechanical and Aerospace Engineering
The University of Alabama in Huntsville
Huntsville, AL 35899

Phone: 256-824-7203; FAX 256-824-7205; Email: frederic@eb.uah.edu

Co-Investigators
Dawn Utley, Charles Corsetti, B. Earl Wells, Rose Norman, Brian Landrum

Period of Performance: 3/1/2002 to 9/30/2002

Report Date: September 27, 2002

frederic@eb.uah.edu

Class Web Page: <http://www.eb.uah.edu/ipt/>

DISTRIBUTION STATEMENT A
Approved for Public Release
Distribution Unlimited

Final Proposal: Unmanned Hybrid Vehicle

IPT 3

Submitted By:



Submitted To:
Dr. Robert A. Frederick
Associate Professor
Technology Hall N231
Department of Mechanical and Aerospace Engineering
University of Alabama in Huntsville
Huntsville, AL 35899
frederic@eb.uah.edu
Class Web Page: <http://www.eb.uah.edu/ipt/>

Contributors

Project Office:	Jennifer Pierce
Systems Engineering:	Brian Akins
Aerodynamics:	Adam Elliott
Propulsion and Power:	Dorothee Barre, Samuel Glemee, Thomas Clerc
Ground Robotics:	Gregoire Berthiau
Mission Simulation:	Christina Davis
Mechanical	
Configuration/Structures:	Patrick Damiani
Avionics, Sensors, Autonomous	Michael Burleson, Claudio
Flight Controls	Estevez
Programmatic Considerations	Jennifer Pierce

Industrial Mentors

Project Office	Jim Winkeler
Systems Engineering:	Tim Hughes
Aerodynamics:	John Berry
Propulsion and Power:	Alain Coutrot
Ground Robotics:	Jim Dinges; Susan Gamble
Mission Simulation:	Brad Miller
Mechanical	
Configuration/Structures:	Kevin Rotenburger; Alex Maciel
Avionics, Sensors, Autonomous	
Flight Controls	Lew Williams; Joe McKay
Programmatic Considerations	Pat McInnis; Dave Gunther

Participating Agencies

Army Aviation and Missile Command	Ecole Superieure des Techniques Aeronautiques et de Construction Automobile
The University of Alabama in Huntsville	The American Helicopter Society
Snecma	Quality Research
Sigma Services of America	HDC
SAIC	Sandia National Laboratory
Programmit-X	Randal Holt & Clifford Laguerre

The University of Alabama in Huntsville
April 25, 2002

Executive Summary

English

Missile and aviation systems must increase use of emerging and advanced technologies in order to remain viable in the complex battlefield environments of the future. Unmanned vehicles will challenge the technologies gained from manned vehicles in future military operations due in part to: the increasing demand for immediate intelligence on the battlefield, decreasing defense budgets, increasing operational tempos, and the low tolerance for casualties by the public. It is these aspects that lead to the proposal of the Chicken Hawk. The Chicken Hawk is a proposed Aerial/Ground vehicle hybrid designed to fulfill the requirements set forth by the Concept Description Document (CDD) in a new way. This particular concept not only takes advantage of good propulsive efficiency and is relatively quiet, but also can perform two different missions at once. When the two units are attached together, the system can drop off the ground unit to deliver medical supplies, ammunition, etc., while the air unit can retrieve another ground unit to perform another mission elsewhere on the battlefield. This vehicle is able to meet the broad demands of the specification. Using off the shelf technology, the anticipated deployment date of 2012 can be easily reached. However, this time must be used wisely. A schedule has been created detailing from now until the first unit is deployed on the battlefield 10 years from now.

French

Les missiles et les systèmes d'aviation doivent utiliser les technologies émergentes et les plus avancées afin de rester viables et compétitifs sur les futurs champs de bataille. Les véhicules sans pilotes mettront à profit ces dernières bien mieux que les véhicules avec pilotes dans les futures opérations militaires, ceci pour plusieurs raisons: la nécessité d'avoir de plus en plus une capacité d'analyse sur les champs de batailles, la diminution des budgets de défense, l'accroissement des "tempos" d'opérations, et la mauvaise acceptation des pertes humaines par le public. Ce sont ces aspects qui ont menés au concept du "Chicken Hawk". Le "Chicken Hawk" est un véhicule hybride terrestre et aérien pensé pour remplir pleinement les conditions régies par le cahier des charges d'une nouvelle façon. Ce concept particulier ne profite pas seulement d'une grande efficacité en matière de propulsion et de son silence partiel, mais il peut également accomplir deux missions différentes en même temps. Lorsqu'ils sont attachés ensemble, le système peut déposer l'unité terrestre afin de délivrer des fournitures médicales, des munitions, etc; pendant que l'unité aérienne peut revenir chercher une autre unité terrestre pour accomplir une autre mission quelques part ailleurs sur le champ de bataille. Ce véhicule peut satisfaire les larges demandes du cahier des charges. Utilisant des technologies d'aujourd'hui, la date de déploiement anticipé de 2012 peut être aisément atteinte. Cependant, le temps doit être sagement utilisé. Un emploi du temps a été créé commençant dès à présent et allant jusqu'au déploiement de la première unité sur le champ de bataille dans dix ans.

2.2.1 Adverse Environmental Conditions.....	2.6.2
2.2.2 Adverse Geographical Conditions.....	2.4
2.2.3 Unimproved Land Facility Day or Night.....	2.4
2.2.4 Detection of Battlefield Obscurants.....	2.6.2
2.2.5 Ground Speed of 6 km/h for 2 h, radius of .5 km...	2.4
2.2.6 Maximum Weight of 1500 lbs.....	2.5
2.2.7 Use Readily Available Diesel or Jet Fuel.....	2.7
2.3 Electronic Capabilities	
2.3.1 Mission Planning System	
2.3.1.1 Point-and-click Pre-Mission Planning.....	2.6.3.1
2.3.1.2 Data Loading Capabilities.....	2.6.4
2.3.1.3 Reaction to Mission Changes.....	2.6.3.1
2.3.1.4 Self Awareness and Threat Sensor Inputs.....	2.6.3.6
2.3.1.5 Enabling TF/TA.....	2.6.3.1
2.3.2 Avionics	
2.3.2.1 Compatible with Military Data Links.....	2.6.1.3
2.3.3 Communications	
2.3.3.1 Robust Communications with Secure Modes...	2.6.1.4
of Operation	
2.3.3.2 LOS and BLOS Communications.....	2.6.1.3
2.3.3.3 IFF and Compliant to FCC/Military Regulations.	2.6.1.2
2.3.3.4 Communication and Data Sharing With.....	2.6.3
other DoD RISTA Platforms	
2.3.4 Connectivity	
2.3.4.1 2012 Battlefield.....	1.3

Table of Contents

List of Figures.....	viii
List of Tables	ix
Common Terms and Acronyms List.....	x
Team-Specific Terms and Acronyms List	xii
IPT 3: Feasibility of Unmanned Hybrid Vehicle	1
1.0 UHV – Unmanned Air/ Ground Vehicle.....	1
1.1 The Need	1
1.2 The Requirements.....	1
1.3 The Solution.....	2
1.3.1 Concept Overview	2
1.3.2 Dimensional Properties.....	4
1.3.1 Operations Scenario.....	5
1.4 The Performance.....	7
1.5 The Implementation.....	7
2.0 Technical Description of Methods Used	8
2.1 System Engineering	8
2.2 Aerodynamics	11
2.3 Propulsion and Power	14
2.3.2.1 Main Rotor Transmission	16
2.3.2.2 Tail Rotor Transmission	17
2.3.2.4 General Layout of the System	18
2.4 Ground Robotics/Vehicle	19
2.5 Mechanical Configuration/ Structures	23
2.6 Avionics/Flight Controls.....	26
2.7 Mission Simulation	30
2.8 Technical Summary.....	33
3.0 Implementation Issues.....	36
3.1 Programmatic Ground Rules and Assumptions	37
3.2 Work Breakdown Structure	37
3.3 Life Cycle Schedule.....	39

3.4 Life Cycle Costs.....	40
3.5 Risk Analysis	40
3.5 Discussion of Application and Feasibility	41
4.0 Company Capabilities	41
4.1 Company Overview	41
4.2 Personnel Description.....	42
5.0 Summary and Conclusions	43
6.0 Recommendations	43
References.....	45
Appendix A - Concept Description Document.....	48
Appendix B - White Paper	53
Appendix C - Sample Calculations.....	71
C1 – Aerodynamics	71
C2 - Aerodynamics.....	75
C3 – Propulsion.....	76
C4a - Ground Robotics- Ground vehicle electric motor	79
C4b - Ground Robotics- Ground vehicle battery system.....	80
C5 - Avionics.....	82
C6 - Mechanical Configurations.....	83
C7 - Programmatics.....	84
Appendix D – Web Pages	85

List of Figures

Figure 1 Artist Drawing	3
Figure 2 CATIA Drawing	4
Figure 3 CATIA Three-View Drawing.....	4
Figure 4 Operations Scenario.....	6
Figure 5 Overview of Basic Design Process.....	10
Figure 6 Total Power Requirements in Level Flight	12
Figure 7 Power Required to Climb at 500fpm.....	12
Figure 8 Tail Rotor Power Requirements	13
Figure 9 Power in Forward Flight (Main Rotor Only)	13
Figure 10 ZOCHE ZO 01A.....	15
Figure 11 General Layout of Main Rotor Transmission System.....	16
Figure 12 Tail Rotor Transmission System	17
Figure 13 Main Rotor.....	18
Figure 14 Transmission System Cross Sectional Drawing.....	18
Figure 15 Strength Reached with Surface Treatment	19
Figure 16 Force diagram.....	20
Figure 17 Imperial Electric DC Motor.....	20
Figure 18 Motor Dimensions	21
Figure 19 Saft Batteries	21
Figure 20 Ground Vehicle Avionic Batteries	22
Figure 21 Cross Sectional Drawing	35
Figure 22 Program Work Breakdown Structure	38
Figure 23 Overall Technology Development Schedule.....	39
Figure 24 Cross sectional of bevel.....	76
Figure 25 Determination of the Y value as a function of the number of teeth	78

List of Tables

Table 1 Range and Endurance for two Scenarios	6
Table 2 Final Concept Evaluation – Baseline Mission Profile	7
Table 3 Programmatic 10 year schedule	8
Table 4 Summary of Calculations.....	11
Table 5 Summary of Propulsion Data and Calculations.....	15
Table 6 Size of the Epicycle and Bevel Gearwheels	16
Table 7 Size of the Gearwheels	17
Table 8 Chassis Weight Calculations	24
Table 9 Center of Gravity Calculations	25
Table 10 Power Requirements for the Flight Phases.....	31
Table 11 Excel Spreadsheet to Determine Fuel Requirements.....	32
Table 12 Fuel Requirements	33
Table 13 Weight Breakdown for the Chicken Hawk.....	34
Table 14 Concepts Technical Information.....	36
Table 15 Life Cycle Cost Per Unit.....	40
Table 16 Design of five gearwheels.....	77

Common Terms and Acronyms List

Word	Comments
AGL	Above Ground Level
AMCOM	United States Army Aviation and Missile Command
BLOS	Beyond Line of Sight
BSFC	Brake Specific Fuel Consumption
CAD	Computer aided design
CDD	Concept Description Document-Document that details the customer's technical specifications for the UA/UGV
CPU	Central Processing Unit
DoD	Department of Defense
ESTACA	Ecole Superieure des Techniques Aeronautiques et de Construction Automobile
FCR	Fuel Consumption Rate
FLIR	Forward Looking Infrared
FLOT	Forward Line of Troops
Ft	feet
FY	Fiscal Year
GPS	Global Positioning System
HMMWV	High Mobility Multipurpose Wheeled Vehicle
IFF	Identify Friend or Foe
IOC	Initial Operating Capabilities
IPT	Integrated Product Team
IRP	Intermediate Power Rating
km	Kilometer
LED	Light Emitting Diode
lbs	pounds
LRIP	Low-Rate Initial Production
MACC	Multi-Application Control Computer
MAE	Mechanical and Aerospace Engineering
MechCon	Mechanical Configurations
MIAG	Modular Integrated Avionics Group
MS	Milestone
NOE	Nap of the Earth
O&S	Operating and Support
Payload	Item carried by the system having a specified weight
RISTA	Reconnaissance Surveillance Intelligence and Target
RMS	Root Mean Square
TBD	To be determined (not know at this time)
TBE	Teledyne Brown Engineering
TF/TA	Terrain following/terrain avoidance
UAH	The University of Alabama in Huntsville
UAV	Unmanned Air Vehicle

UGV	Unmanned Ground Vehicle
UHV	Unmanned Hybrid Vehicle
US	United States
VROC	Vertical rate of climb
VTOL	Vertical takeoff and landing
WBS	Work Breakdown Structure

Team-Specific Terms and Acronyms List

Word or symbol	Comments
A_c	Area
C_D	Drag Coefficient
D	Vehicle Drag
V	Vehicle Air Speed
ρ	Density at 4000 ft , 95 ⁰ F
P_i	Induced Power
W	Weight
σ	Solidity
Ω	Angular Velocity
AoA	Angle of Attack
R_c	Rate of Climb
FM	Figure of Merit
σ_s	Strength
θ	Angle of Incline
lbf	Pounds Force
F	Force
z	Number of Teeth
d	Diameter
m	Module
b	Width of the Wheel
c	Torque
r_m	Radius
K_v	Safety Coefficient
P	Power
pas	Pitch

IPT 3: Feasibility of Unmanned Hybrid Vehicle

1.0 UHV – Unmanned Air/ Ground Vehicle

1.1 The Need

Unmanned vehicles will play an extensive role in 21st century warfare. Information dominance will be the key to success for our military forces. The need for situational awareness, target identification, dominant battlefield awareness, dominant battlespace knowledge, and information superiority has been voiced by the military for many years (Grover 1998). Unmanned air/ground vehicles can make this a reality.

Advances in technology, greater acceptance and high profile demonstrations of capabilities have resulted in broad support for and increased interest in unmanned systems. Funding has increased, new program starts are occurring with greater frequency and proponents at the highest levels of government are speaking out in favor of unmanned technologies.

Recent world events have rapidly accelerated the need for capabilities provided by unmanned systems. "We are entering an era in which unmanned vehicles of all kinds will take on greater importance, in space, on land, in the air and at sea"(President Bush 2001). The Unmanned Hybrid Vehicle (UHV) is intended for use at the battalion level to assist medium and light forces and increase their effectiveness. These technologies add new strength to worldwide missions while reducing high-risk or even lethal exposure to personnel.

Robotic platforms are essential to penetrate physically prohibitive areas and even serve as an extension of the human soldier (www.saic.com Accessed 7 April 2002). These robotics can deploy rapidly to the point of interest and can augment the power of the troops by performing multiple missions without the risk to human life. These devices also help the military deal with manpower cutbacks and allow troops to have more eyes and ears across the battlefield (<http://www.azstarnet.com/attack/indepth/wsj-robotjeeps.html> Accessed 7 April 2002).

The US Army Aviation and Missile Command (AMCOM) has specified these needs. Reconnaissance missions performed by soldiers on the forward line of troops (FLOT) are extremely dangerous, and are impossible beyond line of sight (BLOS). The UHV will allow the FLOT to make more informed and better decisions by enhancing the reconnaissance, intelligence, surveillance, and target acquisition (RISTA) capability of their respective battalions. AMCOM must incorporate these technologies to remain viable in the battlefield.

1.2 The Requirements

The US Army Aviation and Missile Command has challenged Phoenix Technologies to develop a vehicle that integrates both a UAV and UGV to perform missions normally performed by soldiers in the battlefield. AMCOM first presented us with the Concept Description Document, which lays out all the requirements for this type of operational capability. In more general terms, the UHV must meet the Army's needs. This need calls for an intelligent and autonomous vehicle that is capable of performing a preplanned or diverted duty. It must have maximum survivability and be capable of keeping up with the operational tempo. It must enhance the RISTA and battlefield damage assessment (BDA).

It must also meet the mission/payload requirements. This involves being able to fly to operational range, which is 15-30 km ahead of the fighting force, in 30 minutes or less while flying nap of the earth, which makes it capable of detecting and operating under battlefield obscurants. Upon reaching this site, while transporting critical payloads between 60 and 120 lbs, the vehicle will land and drop off the payload. When this mission is complete, the UHV will then return to the launch area.

The UHV requirements are the actual performance characteristics that the vehicle must meet to perform the mission. This includes flying between 30 and 100 km/hr with a VROC of no less than 200 ft/min. This vertical rate of climb will enable the UHV to fly in a nap of the earth configuration and the capability to take evasive action if necessary. It shall also be capable of landing on unimproved roads at a ground speed of no less than 6 km/hr at a radius between 0.5 and 1 km at a grade of no more than 12 degrees.

Some of the key challenges of this type of system are technologically and integration based. This type of system must be intelligent in order for it to monitor, think and react to a situation. Artificial intelligence is constantly evolving. We are constantly learning new ways to build working systems that extend and test ideas. Also, tying in capabilities of a system with both an air and ground unit together has a big issue with weight. Most propulsion systems are bulky and have a high specific fuel consumption. Also reducing the weight with lighter and stronger materials along with a high efficiency engine is the challenge and the future of this vehicle.

1.3 The Solution

1.3.1 Concept Overview

The system is best illustrated as shown below in Figure 1. The Chicken Hawk is a unique vehicle in both the way it meets system requirements and in its robustness as a combat tool. The key to this system is that it is composed of two separate vehicles. A typical mission would be carried out as follows: the system takes off from the initial point like a standard helicopter, powered by a diesel engine that drives a single main and tail rotor combination. It flies "nap of the Earth" to help avoid visual and radar detection. Once it arrives at the preprogrammed objective, the vehicle lands and the engine shuts down. The ground portion of the vehicle then separates from the helicopter portion. This ground portion, which has been located "inside" the "Mother ship", contains most of the avionics and sensors. Now on its own, the electric drive system propels the ground vehicle to carry out the mission. Once the mission has been accomplished, the ground vehicle returns to the aircraft and docks. The diesel is then restarted and the entire package flies home to be refueled, reloaded and reprogrammed for another mission. This is a basic scenario, which can be extensively modified to allow for maximum mission flexibility.

To better visualize the system concept, Figure 2 shows an isometric layout of the vehicle, which highlights some of the main features. The engine and transmission provide both mechanical power to drive the vehicle in the air and electric power to recharge the batteries of the ground vehicle as well as run the internal electronics. Each vehicle contains an onboard computer to manage data flow and operate the vehicle. The primary sensor package

lies in the ground vehicle. This package provides the sensory data needed during flight and the information is relayed to the air vehicle. It also provides similar data during the ground portion of the mission. Having only one set of sensors reduces system complexity and weight. For communication each vehicle carries a satellite radio, which allows independent communication to the base station and provides some redundancy.



Figure 1 Artist Drawing

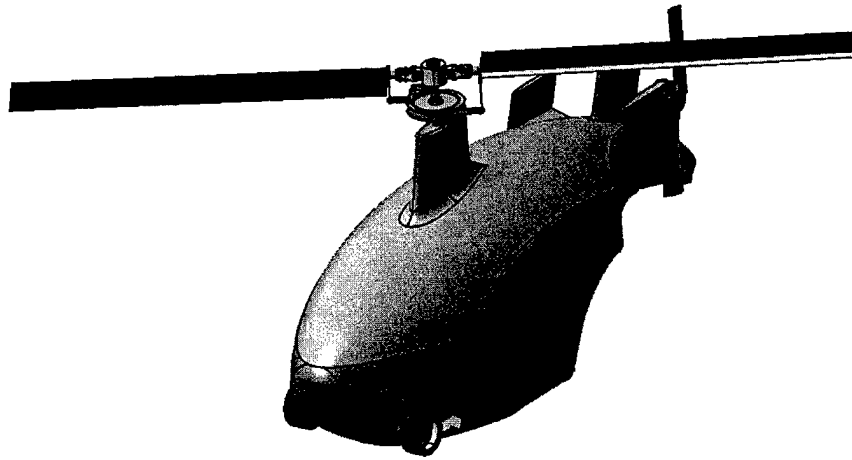

Figure 2 CATIA Drawing

1.3.2 Dimensional Properties

Figure 3 shows a three-view drawing of the Chicken Hawk when the two portions are assembled.

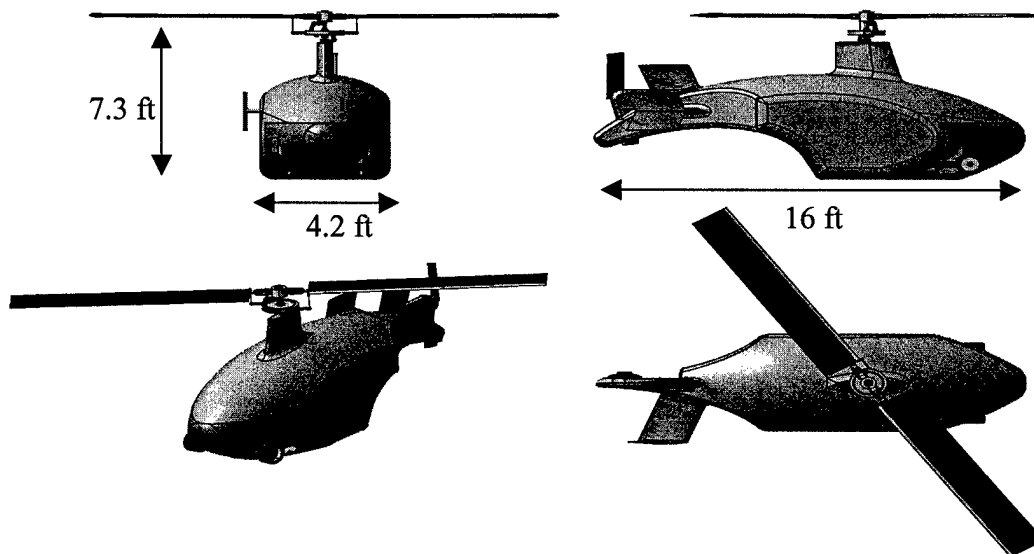

Figure 3 CATIA Three-View Drawing

Considering the dimensions of the trailer of the HMMVW, which are 7'6" x 4'2", the UHV can be carried in, even if the blade will stand out on the front part (without touching the HMMVW), and the tail also will stand out on the rear part.

1.3.3 Operations Scenario

In accordance with the CDD, the UHV is able to perform the Baseline Mission Profile illustrated in Figure 4. The UHV is able to operate at an altitude of 4000 feet with a maximum temperature of 95°F. And it is capable of achieving a VROC of between 200 and 500 fpm.

The Baseline Mission Profile is accomplished by the Chicken Hawk by the following steps. In segment 1, the Chicken Hawk is allowed 5 minutes to warm up in idle. This is to allow the engine to reach a steady state condition to allow most efficient use of the engine power. In segment 2, the Chicken Hawk goes to a hover position in preparation for a vertical climb. The Chicken Hawk is allotted 2 minutes for hovering at this point. In segment 3, the Chicken Hawk performs a vertical climb to the combat operational altitude of 250 feet. The vertical rate of climb for this section is 500 fpm. Based on these requirements it takes about half a minute for the Chicken Hawk to reach the operational altitude. In segment 4 the Chicken Hawk is ready to cruise outbound to the operational range. This is performed at NOE at a maximum velocity of 30 km/hr. The CDD requires that the time of flight to the operational range be 30 minutes or less. Therefore the distance to the operational range is 15 km. In segment 5 the Chicken Hawk descends in preparation for the beginning of the ground maneuvers. The descent is performed using the same VROC as with the climb. The time required to perform this operation is half a minute as well. In segment 6 the Chicken Hawk performs a hover and landing maneuver, which takes approximately 2 minutes. After the Chicken Hawk is on the ground, the engine, which is the power supply for the aerial vehicle, is shut down. Then the ground vehicle, which is powered by self-contained batteries and electric motors, exits the aerial vehicle. Now the UHV has separated into a UAV and a UGV. Although the UAV is non operational in the physical sense in this scenario, the avionics are still operational using battery supply. This is done to satisfy the requirements of the CDD. As will be seen later, this vehicle is capable of performing more missions, which involve the UAV operating during the UGV maneuvers. In segment 7 the UGV travels for 0.5 km at 6 km/hr. This takes approximately 5 minutes. Once the UGV reaches 0.5 km, the payload is delivered and the UGV returns to the UAV. The UGV is capable of traveling on terrain that is composed of unimproved roads, which could have a grade of no more than 12 degrees up or down and particles that have no more than an RMS of 1 inch. This is a total round trip of 10 minutes for 1 km; however the UGV is capable of traveling for no less than 2 hours. Once the UGV returns to the UAV and docks, the Chicken Hawk starts the cycle for returning. Although there is not a segment shown for warm up and idle, because the engine was shut off there is 5 minutes allowed for warm up and idle. In segment 8 the Chicken Hawk performs a take off and hover. In segment 9 the Chicken Hawk performs a vertical climb to the operational altitude. In segment 10 the Chicken Hawk cruises inbound, returning to the initial starting point. In segment 11 the Chicken Hawk descends for hover and landing operation. And in segment 12 the Chicken Hawk hovers and lands, with a 10% fuel reserve.

While on the battlefield, during all operations, the Chicken Hawk is capable of sensing weather, chemical/biological weapons, and friendly or enemy targets. All of these operations are performed by the avionics/electronics systems. The specific purposes and capabilities of these systems are discussed later. In addition, the Chicken Hawk is capable of carrying a minimum payload of 60 pounds during all operations

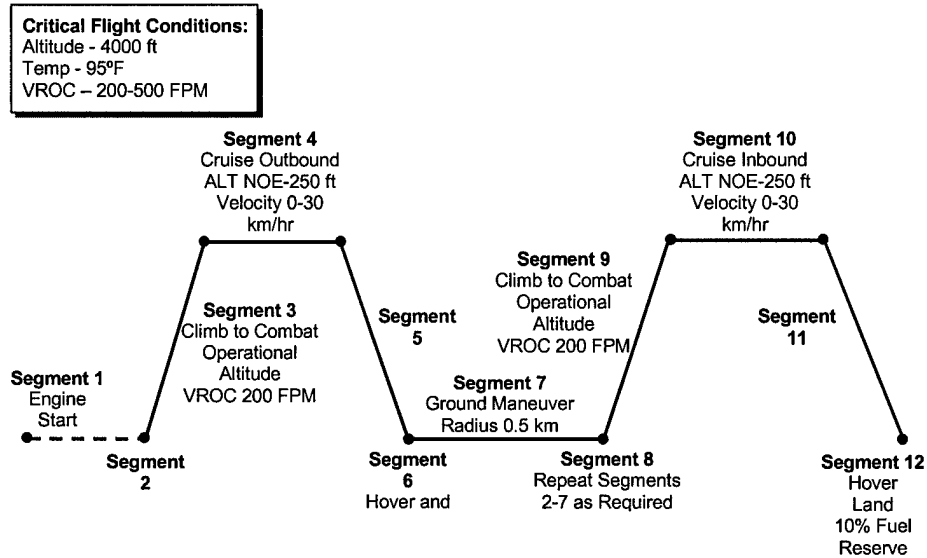

Figure 4 Operations Scenario

As mentioned before, the mission scenario just described is only based on the Baseline Mission Profile and the CDD requirements. However this vehicle has several applications that go far beyond the CDD requirements. All of these applications stem from the fact that this vehicle is two in one. It takes all of the capabilities of a UAV and UGV and puts them into one.

The most important aspects of this vehicle occur during the ground maneuver, when the Chicken Hawk is separated into the UAV and the UGV. During this time, it is possible for the UAV to perform separate missions while the UGV is deployed. For example, the UAV could travel back to the home base and retrieve more UGV's to bring to the operational range for deployment. It is also possible because of this separation that in case the UGV is lost the UAV can return to the base. This way there is less cost involved in case the UHV is damaged. Table 1, gives the ranges and endurances for two scenarios based on the baseline fuel load of 53.78 lbs (7.38 gallons) and the maximum fuel load of 93.24 lbs (20 gallons).

Table 1 Range and Endurance for two Scenarios

Fuel Load (lbs)	Scenario	Range (km)	Endurance (hrs)
53.78	A	64.22	2.14
53.78	B	-	1.10
93.24	A	111.35	3.71
93.24	B	-	1.91

In Table 1, two scenarios are compared for the different fuel loadings, the baseline fuel load and the maximum fuel load. Scenario A is if the UHV is allowed to takeoff and cruise at 30 km/hr until there is 10% of the beginning fuel load remaining. Scenario B is if the UHV is allowed to takeoff, climb to operational altitude, and hover until there is 10% of the beginning fuel load remaining.

1.4 The Performance

The system as designed will meet all of the mission requirements set forth by the baseline mission profile. The Chicken Hawk meets or exceeds each requirement set forth in the CDD. A more itemized listing of the final concept evaluation can be seen in Table 2.

Table 2 Final Concept Evaluation – Baseline Mission Profile

CDD Requirement	Requirement	Assessment	Remark
Payload	60 lbs	Exceeds	Can carry 120 lbs
Endurance	4 hours	Meets	
Flight Profile	Hover-Full	Meets	
Vertical Climb	200 fpm	Exceeds	Can climb at 500 fpm
Operational Altitude	0 – 250 ft AGL	Exceeds	
Airspeed	30 km/hr	Exceeds	Can cruise at 259 km/hr at full power
Ground Speed	6 km/hr	Meets	
Operation	Semi-autonomous	Meets	
Communication	BLOS	Meets	
Transportable	HMMWV, UH-60	Meets	
Max System Weight	1500 lbs	Meets	Total system weight =1402 lbs (wet)
Deployment	2012	Meets	
Multiple Mission Profiles	Can carry out multiple mission profiles	Meets	

1.5 The Implementation

Final planning and design for the Chicken Hawk should begin now in order to ensure successful completion of the project by the year 2012. This system uses existing off the shelf hardware and proven systems. By modifying and improving proven technologies, AMCOM will receive the maximum vehicle for the minimum price. To develop non-standard

technologies, while providing for an advanced system, will drive development costs much higher as well as possibly lengthening the development timeline.

Since the Chicken Hawk does not rely on anything to be invented, the design process can move from design to system integration and prototyping much faster than if new components had to be developed on their own. This in turn allows for a longer testing and evaluation period before full-scale production and subsequent deployment begins. By doing this, the system has a much higher chance of meeting the mandated 10-year timeframe, as shown in Table 3, with ample time for testing and training personnel on the system, as well as having more of the “bugs” worked out of the system. By providing a way to carry out a variety of missions in a reliable system, the Chicken Hawk will be an invaluable tool on the battlefield of the future.

Table 3 Programmatic 10 year schedule

	2002	2003	2004	2005	2006	2007	2008	2009	2010	2011	2012
Contract start	■										
Development of design		■									
Manufacturing of prototype			■	■							
Testing prototypes				■	■	■					
Redesign after testing						■					
Full manufacturing run											
Units in field										■	■

2.0 Technical Description of Methods Used

In this section the technical questions and design details will be covered. The topics for each discipline are addressed in each subsection of this portion of this report. Each discipline-specific problem is addressed as is the approach taken to solve the problem. The underlying theories and analyses are shown as well as how these solutions were used to deal with the aforementioned problems. Any components or techniques that are used to specifically meet the CDD requirements are noted as well.

2.1 System Engineering

When this project began, some critical ground rules were set as well as how the team would approach the design. To meet the deployment timeline and to maximize time available for testing and evaluation, a rule was set that this system would only use existing, “off the shelf” hardware. By using tested and proven technologies and components, the initial development time is minimized, most of that time being dedicated to system integration. After the baseline design was made, Phoenix decided to start from scratch, using the baseline as a lessons learned model. Each team member brainstormed a new way of carrying out the baseline mission, with little thought into the vehicle specifics. By coming up with a very general idea and developing a system around it, innovation can be maximized given the restriction of using existing technology. If a vehicle was sketched out and then modified to adapt to the mission, one would have little innovation and end up with essentially the same product one started with (Dieter 2000).

As described in the Phase 2 White Paper, located in Appendix B, the Chicken Hawk concept was selected as the best using a controlled convergence matrix. The three concepts were

compared to the baseline in their ability to meet the CDD. Now that the concept had been chosen, the team was asked individually to think about potential problems with designing the vehicle, critical design parameters and more brainstorming on how to design the vehicle. A list was compiled afterward and each problem was addressed as an entire team. By involving everyone in the discussion, Phoenix maximized the talents of each individual as well as keeping everyone on the team up to date on decisions and tasks. The team leader made any decisions, upon which a compromise could not be reached.

As the design process began, the team needed to make some trade off decisions and ensure feasible design solutions. The approach was to take proven, low-risk technologies, which would maximize the likelihood of a successful product, and combine them in an innovative way to produce a versatile and reliable vehicle. From the beginning the team wanted to meet as many of the desired requirements as possible, though not at the sacrifice of any other requirements. Some of the critical design parameters that were addressed were: type of rotor system (single with tail or coaxial), type of power plant, method of propelling the ground vehicle, sensor and communication capabilities and all of the interfacing between the two main components of the vehicle. Each one of these was evaluated on its ability to meet the CDD as well as weight, cost, reliability, maintainability, size, and overall compatibility with the rest of the system. Though these choices were made early in the design process, they were constantly evaluated throughout the project, and any item needing revision or change was made once the team had more data on which to base a final decision.

Once the major design parameters were selected, the more detailed design work could begin. Figure 5 shows how the information flowed from one area to another and the design progressed.

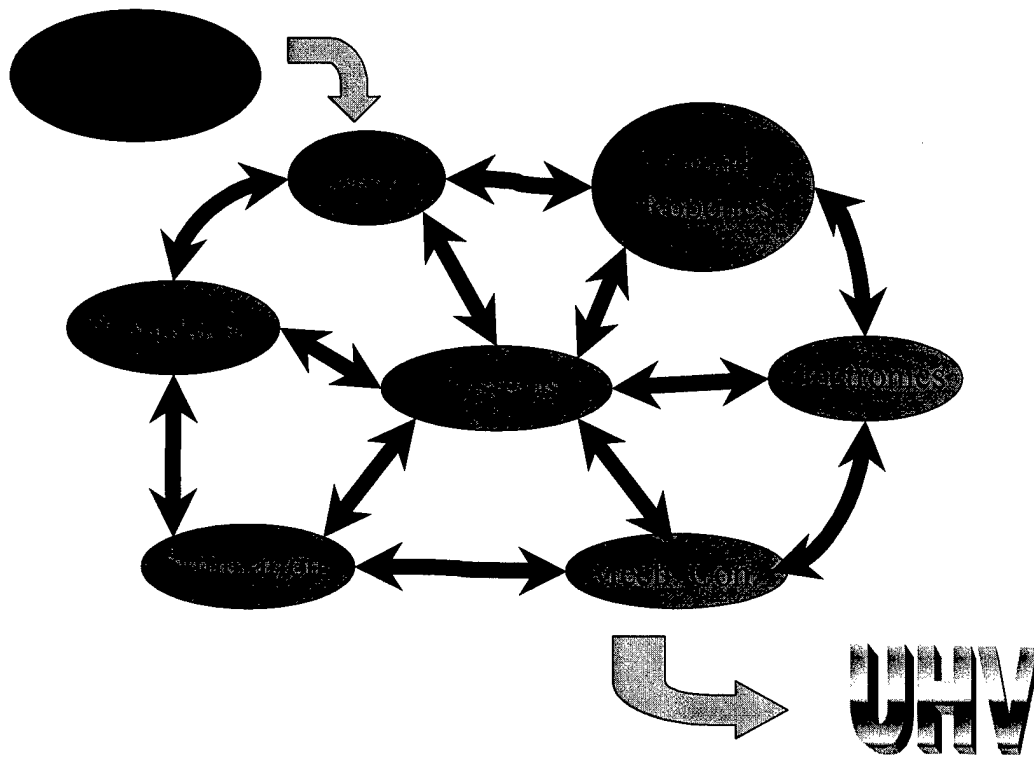

Figure 5 Overview of Basic Design Process

As seen in Figure 5, each discipline's results were used as inputs to the other disciplines. In some cases, results from one discipline, such as aerodynamics, could have a major impact on one or more other groups, such as propulsion and simulation. After the initial assumptions were given by systems engineering, the information and design work flowed in a generally circular fashion. This design hierarchy was shown to the team at the beginning of the project so everyone would know what the "big" picture looked like. Systems engineering directed the specific data flow, both to prevent confusion between disciplines as well as making sure each group was providing the correct results. Here the term "correct" is not used in a numerical accuracy sense (though unreasonable numbers were brought to the provider's attention); the systems group was making sure each group was answering the right question. This minimized wasted time as well as confusion across the organization.

As the project progressed, most of the entire process was repeated as more specific and correct outputs for each discipline became available. After several iterations of the process were made, the whole team examined the entire system. Each discipline checked their work as well as any interfacing problems with other disciplines. In addition to compatibility, the system weight was the primary area needing revision. The weights for each subsystem were provided to the system engineer and mechanical configuration. Once gathered, a factor of 40% was added, as historically this number tends to account for all additions to the design as well as necessary materials not accounted for in each subsystem, such as wiring weight, nuts, bolts, etc. This addition was made after everyone submitted their weight calculations to ensure consistency and that this factor was not added multiple times.

2.2 Aerodynamics

Table 4 Summary of Calculations

Main Rotor Airfoil	NACA 4421
Main Rotor Span	16 ft
Solidity	0.053
Aspect Ratio	12
# of Main Rotor Blades	2
Main Rotor Chord Length	16 in
Main Rotor RPM (Hover)	611
Main Rotor Tip Speed	511.8 ft/s
Tail Rotor Diameter	4 ft

Table 4 gives a brief summary of the calculations that are shown in Appendix C1. The main rotor span was limited to 16 feet to make the vehicle more transportable. This restriction caused the main rotor to have a lower aspect ratio; therefore, the main rotor system is slightly less efficient. The following figures describe the helicopter's cruising characteristics. Figure 7 shows the total power requirement of the helicopter including power to drive the tail rotor. The minimum power required for cruise is at approximately 55 mph. This is also true for climbing at 500 fpm. Figure 6, Figure 7, Figure 8, and Figure 9 show power requirements in various situations.

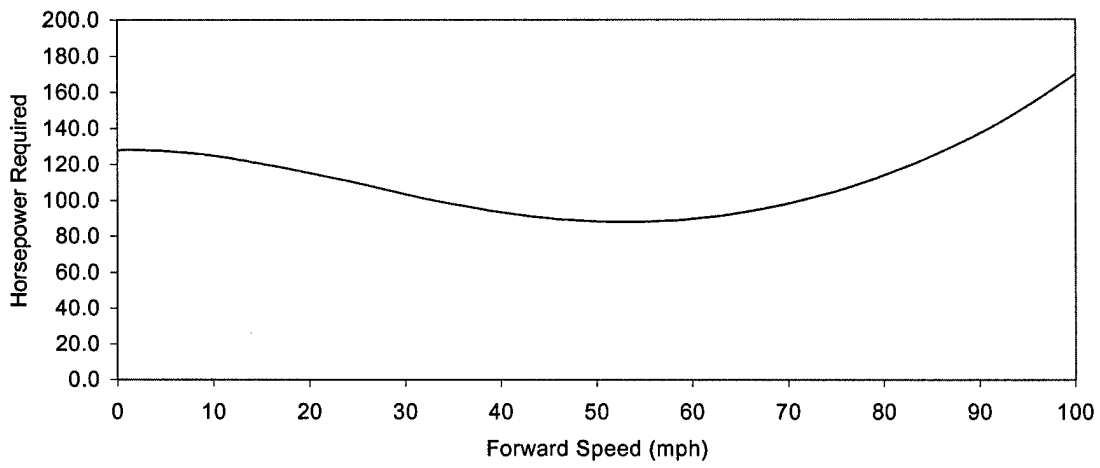

Figure 6 Total Power Requirements in Level Flight

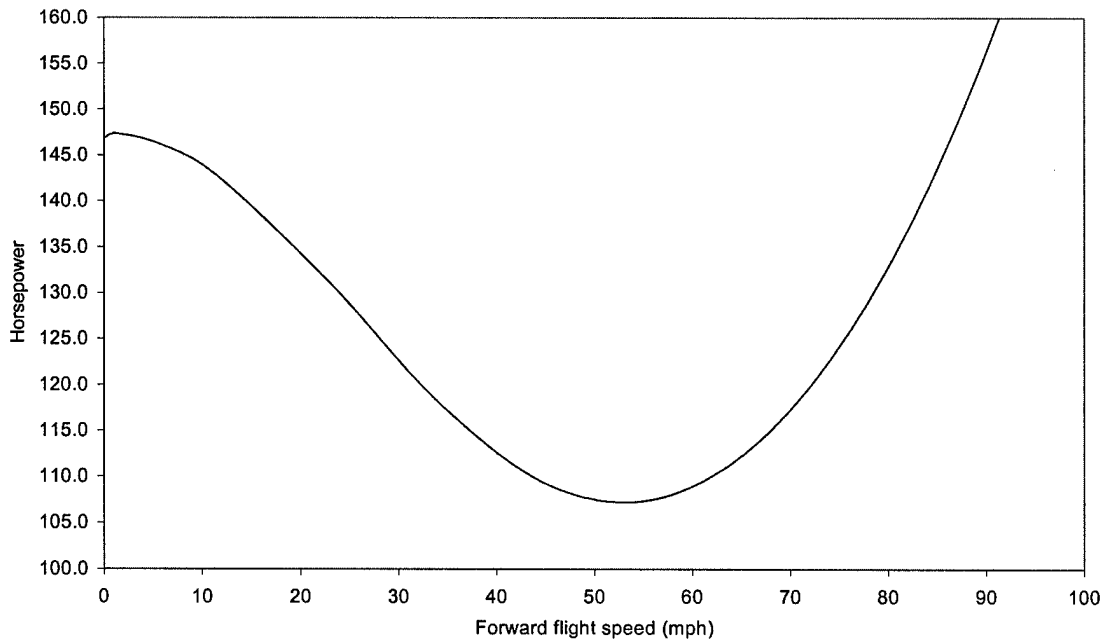

Figure 7 Power Required to Climb at 500fpm

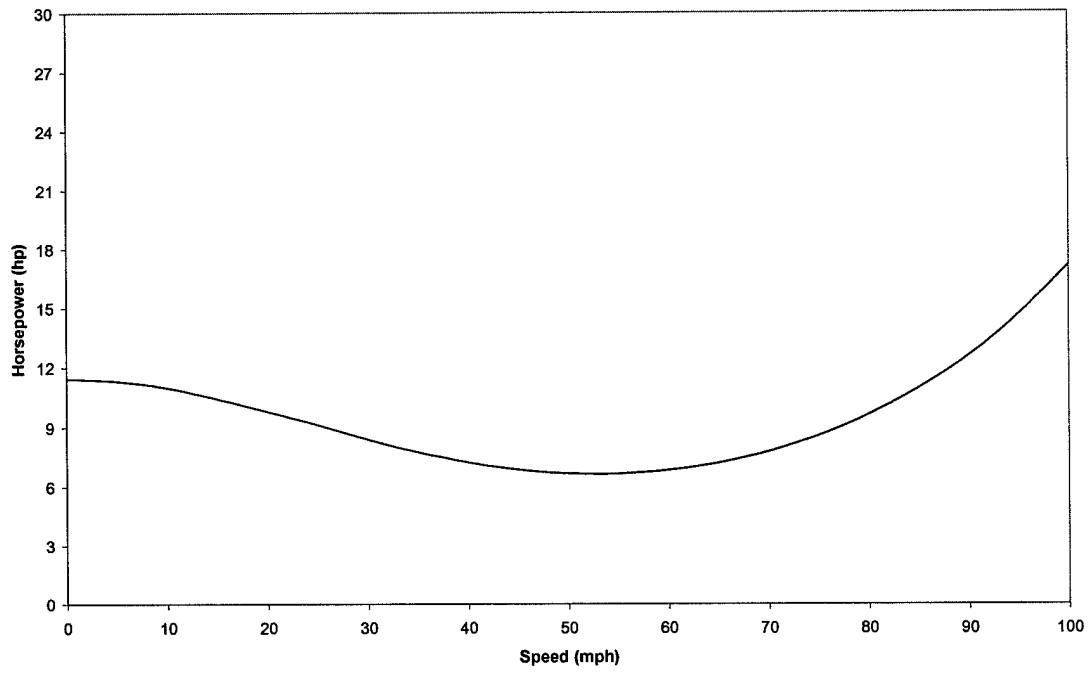

Figure 8 Tail Rotor Power Requirements

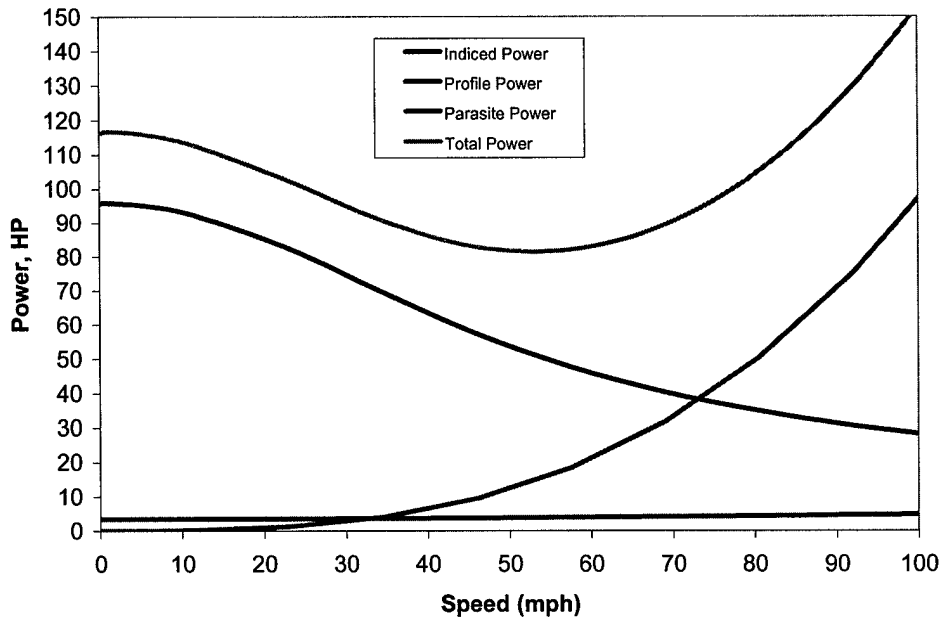

Figure 9 Power in Forward Flight (Main Rotor Only)

The tail rotor power requirements show that a greater amount of power is required to drive the tail rotor at hover. This is because the tail rotor is the only counter torque device in this flight condition. When the aircraft is in forward flight, the tail area provides some counter torque. In Figure 9, the power consumption of the main rotor is plotted (Leishman 1999). This curve resembles the total power curve from the previous figures.

Calculations for the system were performed with some assumptions. First, the design was given a figure of merit to account for various inefficiencies. That value was 0.85. The drag coefficient for the vehicle was approximated. The value used was 1.5. All calculations were performed using some of the following basic equations.

$$P_i = \sqrt{\frac{W_h}{2\rho A}} \quad \text{Equation 1}$$

$$D = \frac{1}{2} \rho V^2 A C_d \quad \text{Equation 2}$$

Equation 1 was used to find the induced power of the helicopter. This is the power required to hover. Equation 2 was used to determine the drag of the vehicle. A complete sheet of calculations is shown in Appendix C1.

2.3 Propulsion and Power

Since the early days of aircraft development, great emphasis has been placed on engine performance. But even today, a major portion of the takeoff weight of aircraft is for the propulsion system. For this reason, the development of lightweight, high efficiency engines continues to be a priority in military, commercial and general aviation.

2.3.1 Propulsion System

The engine chosen is the ZOICHE ZO 01A (<http://www.zoche.de/diesels.htm> accessed 30 March 2002). It is a four cylinder two stroke diesel engine as shown in Figure 10.

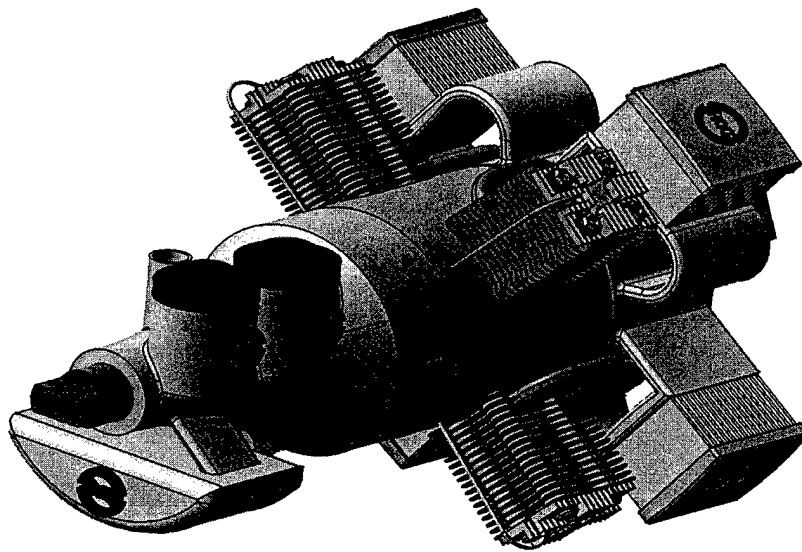

Figure 10 ZOCHE ZO 01A

In this perspective, ZOCHE planned at this time to develop a line of lightweight, fuel-efficient, two stroke diesel engines. This technology is nearly quiet and offers the best power-loading ratio for the requirements. The specifications are shown in Table 5.

Table 5 Summary of Propulsion Data and Calculations

Parameters	ZOCHE ZO 01A
Weight	185 lbs
Power	147.45 hp
RPM	2500 RPM @ max power
Width	21.5 in.
Diameter	24.7 in.
Length	32.9 in.
Consumption	0.365 lb/hp*hr

2.3.2 Transmission System

It is composed of six gearwheels and four shafts to drive the power from the engine to the main and tail rotors. There are also two clutches that allow the engine to work without any rotation of the rotors. The size, the shape and the position of the gearwheels have been calculated in order to deliver the appropriate speed to the rotors.

The engine has two external shafts that have same RPM. This specificity of the engine allows us to have two different transmission systems, one for the main rotor and one for the tail rotor. This layout enables the engine to be put in the rear part of the "Chicken Hawk," and to have a center of gravity just under the main rotor, which means a good stability in flight.

Each transmission system is equipped with a clutch that allows the engine to work and to provide energy to the rest of the system without any rotation of the rotors. The transmissions have been designed to provide the appropriate speed to the two rotors during the hover. The power required to hover is 116.25 hp, so nearly 1700 RPM for the engine shafts. The speeds required at the same time are: 611 rpm for the main rotor and 2793 rpm for the tail rotor. The calculations of the gearwheels can be found in Appendix C3. A box protects both of the reduction systems, which permits good lubrication of the gearwheels.

2.3.2.1 Main Rotor Transmission

The main rotor transmission is made of an engine shaft linked to a clutch and then to the first gearwheel (Epicycle 1). This gearwheel is in connection with a second gearwheel (Epicycle 2), which drives a conic gearwheel (Bevel 1) via an intermediate shaft. This conic gearwheel drives the main rotor shaft via a second conic gearwheel (Bevel 2). Table 6 shows the different characteristics of the gearwheels.

Table 6 Size of the Epicycle and Bevel Gearwheels

	Epicycle(1)	Epicycle(2)	Bevel(1)	Bevel (2)
Max Diameter (in)	7.24	5.12	3.19	12.56
Min Diameter (in)	7.24	5.12	0.43	9.8
Thickness (in.)	1.38	1.38	1.38	1.38
Number of teeth	41	29	18	71

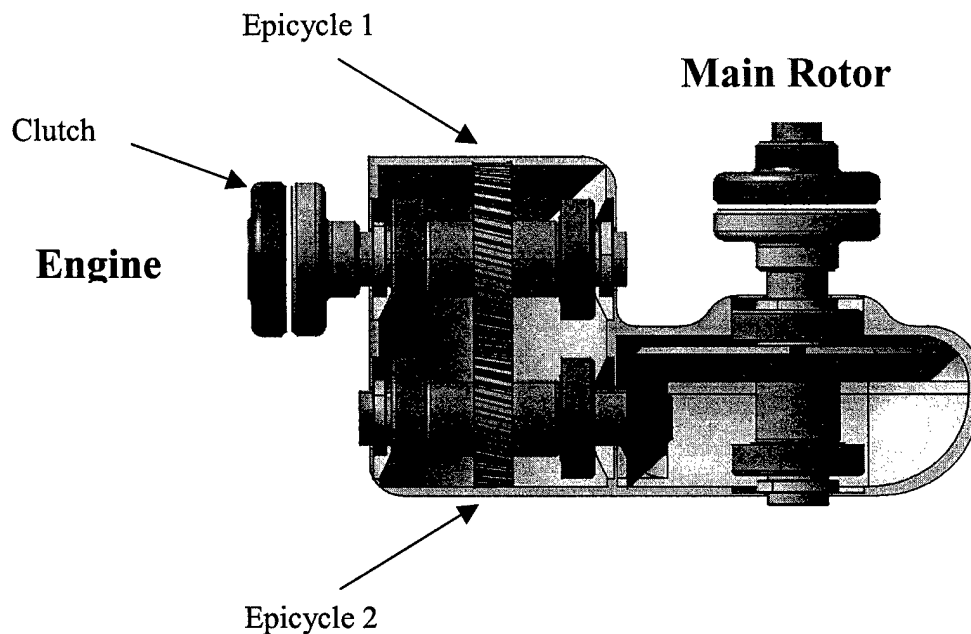

Figure 11 General Layout of Main Rotor Transmission System

These results come from the calculations found in Appendix C3. The general layout of the transmission system is shown in Figure 11 with a main rotor gearbox weight of 55.68 lbs.

2.3.2.2 Tail Rotor Transmission

The tail rotor transmission is made of an engine shaft linked to a clutch and then to the first gearwheel (Epicycle 3). This gearwheel is in connection with a second gearwheel, which is exactly the same as Epicycle 1, which drives the tail rotor shaft. The characteristics of these are shown in Table 7. These results come from the calculations found in Appendix C3.

Table 7 Size of the Gearwheels

	<i>epicycle(1)</i>	<i>epicycle (3)</i>
<i>Diameter max (in.)</i>	7.24	4.41
<i>Thickness (in.)</i>	1.38	1.38
<i>Number of teeth</i>	41	25

The general layout of the tail rotor transmission system is shown in Figure 12 with a weight of 32.46 lbs.

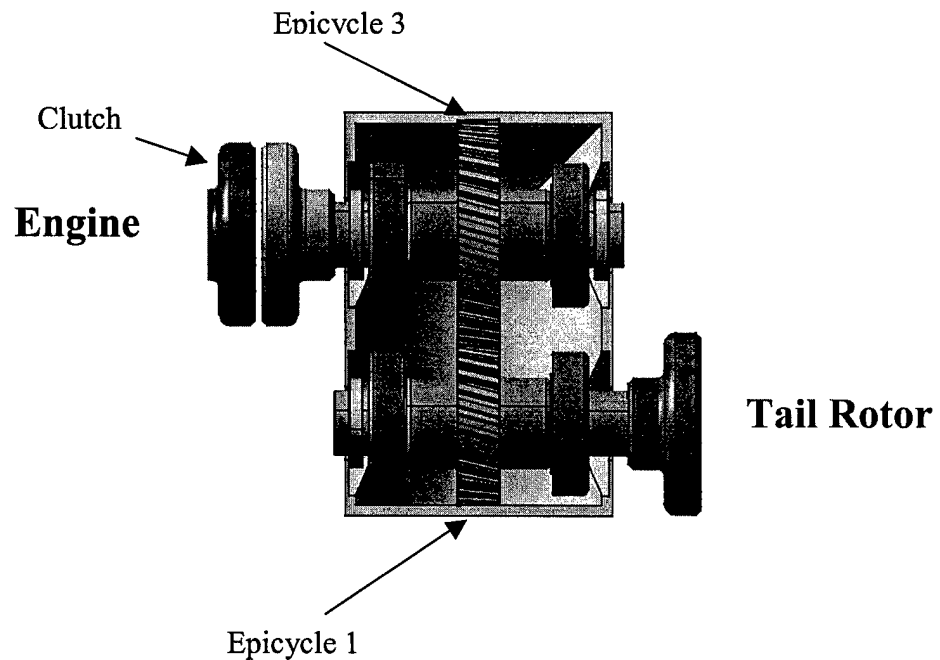

Figure 12 Tail Rotor Transmission System

2.3.2.3 The Main Rotor

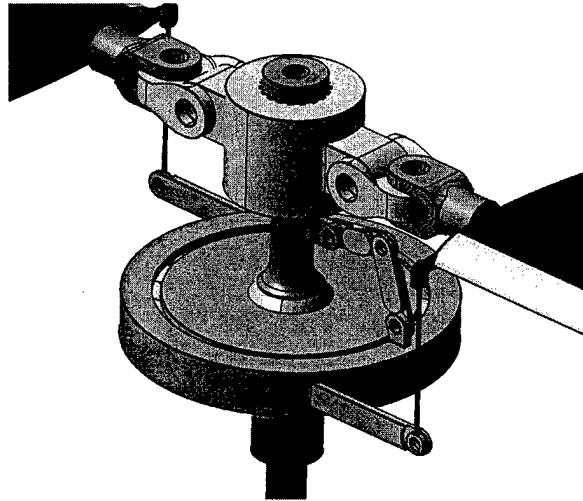

Figure 13 Main Rotor

The rotor designed is a traditional one as shown in Figure 13. The weight of all this transmission system is 88.14 lbs, and with the main rotor the weight is 155.34 lbs.

2.3.2.4 General Layout of the System

The layout of the transmission is shown in Figure 14.

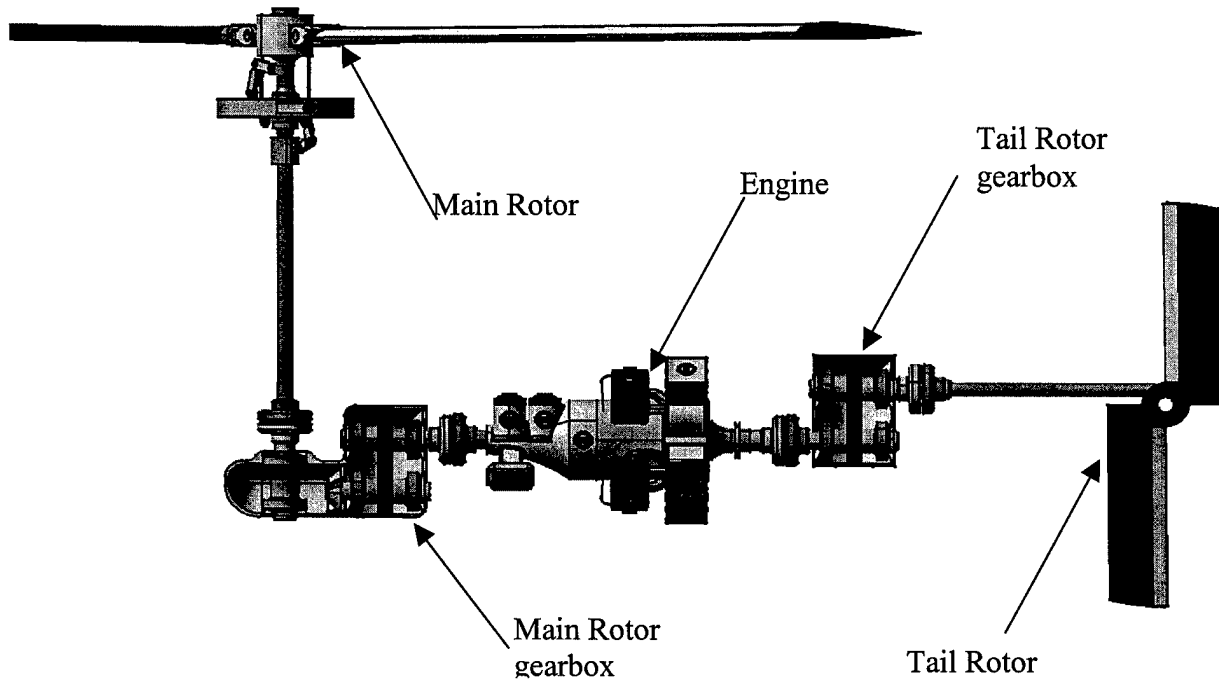

Figure 14 Transmission System Cross Sectional Drawing

2.3.2.5 Materials

For all the transmission system, the gearwheels are in aluminum. The material used to build this transmission is aluminum because of its lightness, but to assure the strength of the teeth of the gearwheel, the surface has been treated with Zinc and Magnesium, to reach the contact surface of the appropriate strength.

This procedure permits us to take advantage of the lightness of aluminum and to assure the viability of our system. The strength reached is about 700 Mpa as shown in Figure 15 (Barralis & Maeder 2002).

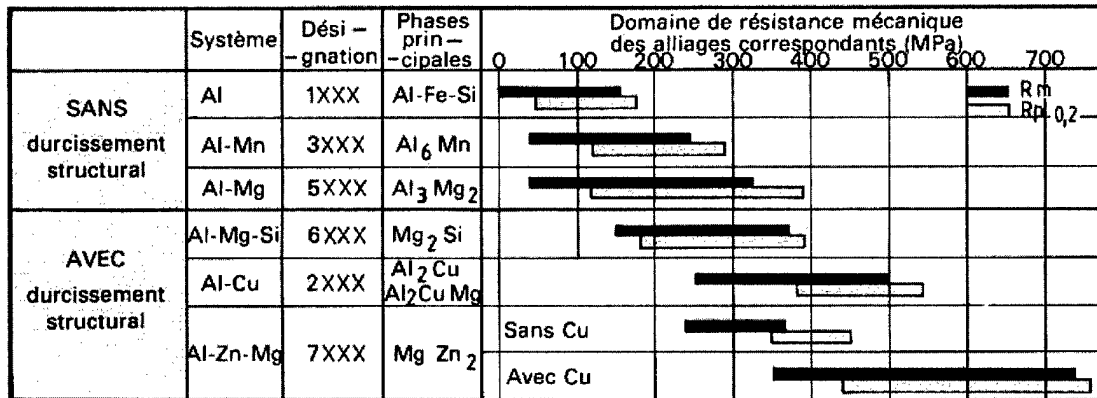

Figure 15 Strength Reached with Surface Treatment

2.4 Ground Robotics/Vehicle

2.4.1 Motors

Requirement 2.2.5 in the CDD states that the vehicle is supposed to drive on unimproved roads. A four wheel configuration has been chosen for the stability of the vehicle. Only the front wheels are powered by two electric motors (directly connected to the wheels) to allow the vehicle to be as silent as possible while the ground portion is performing the mission.

The calculations to process the selection of the different specifications are shown below. Figure 16 also displays the force diagram as the system moves up the incline.

The calculations started with the following assumptions:

- Running speed: 6 km/hr = 5.468 ft/s
- Vehicle weight: 545 lbs
- Maximum slope: 12°
- Wheel diameter: 8 in
- Gravity: 32.2 ft/s²
- Acceleration: 3.28 ft/s²

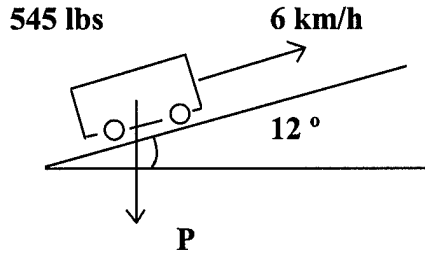

Figure 16 Force diagram

For motion up, the force necessary to make the vehicle move is as shown in Equation 3:

$$F = mg_s \cos\theta + mg \sin\theta \quad \text{Equation 3}$$

$$F = 545 \cos 12 + 419.05 \sin 12 = 167.47 \text{ lbf}$$

The two motors have to provide an output power of 0.72 hp each during the two hours of the mission. Two motors have been chosen of 0.75 hp. This model is a DC motor, as shown in Figure 17, which requires an input of 24 volts and 33 amps of current and has a weight of 21 lbs (<http://www.imperialelectric.com> Accessed 29 March 2002). A complete breakdown of the motor is shown in Appendix C4a.

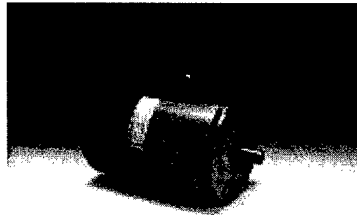

Figure 17 Imperial Electric DC Motor

This motor has the following dimensions as shown in Figure 18, where "A" = 9.24 in. and "B" = 2.4 in.

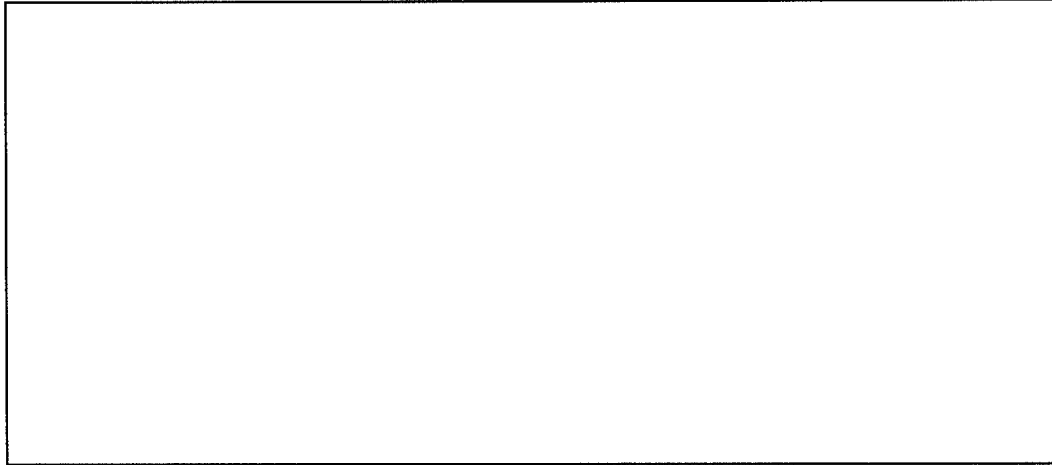

Figure 18 Motor Dimensions

2.4.2 Batteries

Two motors of 33 amps each need to be provided during two hours. Then, the system of batteries has to have a capacity of 132 amp hours ($4\text{hrs} * 33\text{ amps}$). For that, a main battery was chosen of 24 volts and 109 amp hours, and to this battery were added seven batteries in serial of 3.6 volts and 41 amp hours with a weight of 85 lbs as shown Figure 19. A complete breakdown of the batteries is shown in Appendix C4b (<http://www.saftbatteries.com/automotive/uk/> Accessed 30 March 2002).

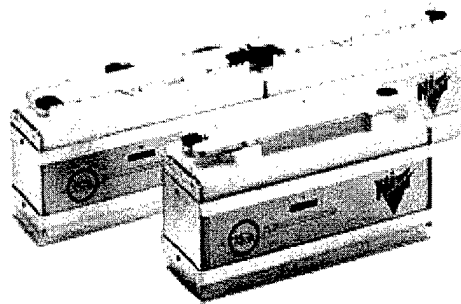

Figure 19 Saft Batteries

The motor has a 1000 to 4000 rpm shaft output. Two systems have to be put between the batteries and the motors. First, a variator controls the voltage input in the motors in order to range the rotation speed at the shaft output. Second, a controller modulates the different voltage at the input of the two motors when the vehicle has to turn, in order to accomplish the differential steering (Bekker 1962).

2.4.3 Wheels

The wheels chosen have an 8-inch diameter and a 4-inch width. Each one weighs 9 lbs. The perimeter of the wheels is as shown in Equation 4:

$$\text{Perimeter} = \Pi * D = 25.13 \text{ inches} \quad \text{Equation 4}$$

In one second, the vehicle has to run at 5.47 ft/s, hence, the wheels have to turn as shown in Equation 5:

$$\frac{5.47}{.642} * 60 = 511.2 \text{ rpm} \quad \text{Equation 5}$$

The reducer then has a 25:1 ratio. The motors insure braking. To brake the motors, the wheels just have to run slower.

2.4.4 Ground Vehicle Avionics

The ground vehicle avionics requires 0.72 hp of power, while the voltage and the amperage that have to be applied are unknown. Eight batteries, as shown in Figure 20, are used. These batteries have an output of 25.2 volts, 41 amp hours and a weight of 16.17 lbs. The complete breakdown of the batteries is shown in Appendix C4b.

(<http://www.saftbatteries.com/automotive/uk/> Accessed 30 March 2002). Equation 6 shows the horsepower required for the avionics.

$$8 * 3.6 * 20 = 7.6 \text{ hp} \quad \text{Equation 6}$$

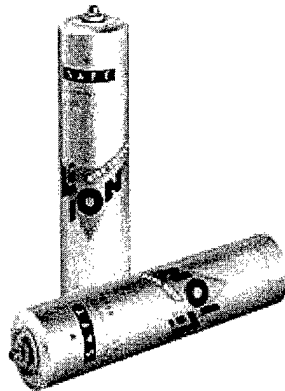

Figure 20 Ground Vehicle Avionic Batteries

2.5 Mechanical Configuration/ Structures

The purpose of the Mechanical Configuration and Structures (MechCon) discipline is organization. MechCon is responsible for designing a chassis that houses all the components of the system and for arranging and shielding such components inside the system, so they do not interfere with each other mechanically, thermally or electro magnetically. Along with this arrangement, the system must also be balanced; meaning the center of gravity must be located at a desired point. This point is usually most important to the static and dynamic stability of the system. MechCon is also responsible for keeping track of weight calculations and totals. Total system weight is a major contributor to the system's dynamic response. All this must be accomplished while packing everything as closely as possible, usually a small aerodynamic form (Dieter 2000).

2.5.1 Chassis

The chassis is a framework on which the system builds on. It is always a custom made structure and is a direct contributor to the size and shape of the vehicle.

In the Chicken Hawk's concept design, there are two separate frames, one for the aerial system and the other for the ground system. Both systems are designed with the same technique. The chassis are composed of 0.5 in² cross-section rods of specific materials interwoven together forming light strong frames with enough surface area to allow component mounting, but not so much area as to drive the weight of the structure too high.

Two materials make up the composition of these rods. The first is a 35% Glass Reinforced Styrene Acrylonitrile polymer (<http://www.matweb.com> Accessed 1 April 2002). This material has a low density to strength ratio but low flexibility. It is an ideal component for dimensionally stable structures. This works best in the main structure of the aerial and ground systems where a larger surface area is needed for part mounting. The other material is Aluminum 6069-T6 (<http://www.matweb.com> accessed 1 April 2002) which has a low density to strength ratio and a good elastic flexibility. This material is ideal for the support structures of the skids and the tail where aerodynamic forces might cause some structure flexing. This aluminum would be too heavy, though, for the larger surface areas.

Table 8 is the chassis weight calculation for the Chicken Hawk. It contains the two main chassis, the ground and the aerial. The aerial contains the base section, tail section, and skiff section. The chassis weight totals at about 52 lbs.

Table 8 Chassis Weight Calculations

Cross-Sectional Area 0.50 in ²				Ground Unit																					
Material 1				# of Rods	Length (ft)	Length (in)	Total Length (in)	Material																	
Styrene Acrylonitrile, 35% Glass Reinforced				3	5.00	60.00	180.00	1																	
Density 0.04913312 lb/in ³				3	3.00	36.00	108.00	1																	
				5	2.00	24.00	120.00	1																	
Material 2				Total Length			408.00	in																	
Aluminum 6069-T6				Volume			204.00	in ³																	
Density 0.09826624 lb/in ³				Weight		10.02	lb																		
Aerial Unit																									
Base Unit					Skiff Unit																				
# of Rods	Length (ft)	Length (in)	Total Length (in)	Material	# of Rods	Length (ft)	Length (in)	Total Length (in)	Material																
2	5.00	60.00	120.00	1	4	5.00	60.00	240.00	2																
4	3.00	36.00	144.00	1	4	2.00	24.00	96.00	2																
1	7.00	84.00	84.00	1	4	0.50	6.00	24.00	2																
5	4.00	48.00	240.00	1	Total Length			360.00	in																
Total Length			588.00	Volume			180.00	in ³																	
Volume			294.00	Weight		17.69	lb																		
Weight			14.45	Weight			10.02	lb																	
			lb	Total Aerial Unit			42.16	lb																	
Tail Unit																									
# of Rods	Length (ft)	Length (in)	Total Length (in)	Material	<table border="1" style="margin-left: auto; margin-right: auto;"> <tr> <td colspan="2">Total Ground Weight</td> <td>10.02</td> <td>lb</td> </tr> <tr> <td colspan="2">Total Aerial Unit</td> <td>42.16</td> <td>lb</td> </tr> <tr> <td colspan="4" style="text-align: center;">Total Chassis Weight</td> </tr> <tr> <td colspan="2" style="font-size: 1.5em;">52.179</td> <td colspan="2">lb</td> </tr> </table>					Total Ground Weight		10.02	lb	Total Aerial Unit		42.16	lb	Total Chassis Weight				52.179		lb	
Total Ground Weight		10.02	lb																						
Total Aerial Unit		42.16	lb																						
Total Chassis Weight																									
52.179		lb																							
1	7.00	84.00	84.00	2																					
2	3.00	36.00	72.00	2																					
1	4.00	48.00	48.00	2																					
Total Length			204.00	in																					
Volume			102.00	in ³																					
Weight			10.02	lb																					

2.5.2 Shielding

Some systems can be very sensitive to outside interference, and some systems produce a lot of interference. The most common types of interference are thermal and electromagnetic. In this conceptual design, there was not much concern for internal interference at this point. Commercially available thermal insulations would be able to protect the electrical systems from the heat of the engine. Not too much effort was made to analyze the possible electromagnetic effects between systems in the conceptual design. This responsibility is still very important, but just too complicated for this phase of development.

2.5.3 Balance

Balancing the system is very important and often very complicated. There are very few components that can just go anywhere. Many must be placed in strategic locations. Items that have a specific placement are positioned first. Then other items are arranged in reasonable locations to balance out the system. Most of the time, the center of gravity does not fall exactly where it should. In those cases, the chassis, which is custom made, can be fabricated to accommodate an asymmetric weight profile to correct the offset center of gravity.

Table 9 is the CG calculation table. The references are: Fore is x, Aft is -x, Port is y, Starboard is -y. The CG in the z direction is important but not as critical at this point in development.

Table 9 Center of Gravity Calculations

Balance						
Aerial Unit		Weight (lb)	x (in)	y (in)	Mx (in-lb)	My (in-lb)
Item						
1	Chassis	42.160	-24.000	0.000	-1011.840	0.000
2	Engine	185.000	22.800	0.000	4218.000	0.000
3	Batteries	8.800	-12.000	-7.200	-105.600	-63.360
4	20Gal Fuel Tank	4.830	0.000	0.000	0.000	0.000
5	Transmission	--	--	--	--	--
5a	Gear Box	85.000	-12.000	0.000	-1020.000	0.000
5b	Main Rotor	68.000	0.000	0.000	0.000	0.000
5c	Drive Shaft	25.000	-66.000	0.000	-1650.000	0.000
5d	Actuators	8.000	0.000	0.000	0.000	0.000
6	Weather D	5.000	51.600	-6.000	258.000	-30.000
7	Avionics	--	--	--	--	--
7a	IFF	5.000	48.000	7.200	240.000	36.000
7b	GPS	1.000	48.000	7.200	48.000	7.200
7c	Radar Altimeter	3.000	48.000	7.200	144.000	21.600
8	CPU	8.000	44.400	0.000	355.200	0.000
9	Radio	6.800	-16.800	-9.600	-114.240	-65.280
10	Sat Com	10.200	-16.800	9.600	-171.360	97.920
11	Encrypting	3.000	-16.800	0.000	-50.400	0.000

Ground Unit		Weight (lb)	x (in)	y (in)	Mx (in-lb)	My (in-lb)
Item						
1	Chassis	10.020	8.500	0.000	85.170	0.000
2	Batteries	--	--	--	--	--
2a	Drive Bat	129.360	-19.200	0.000	-2483.712	0.000
2b	Elec Bat	16.170	-19.200	0.000	-310.464	0.000
3	Motors (x2)	39.680	20.400	0.000	809.472	0.000
4	Drive	44.090	-4.000	0.000	-176.360	0.000
5	Radio	6.800	-27.600	-7.200	-187.680	-48.960
6	Chem Detector	10.000	40.800	-7.200	408.000	-72.000
7	GPS	1.000	36.000	13.200	36.000	13.200
8	Optics	25.000	40.800	0.000	1020.000	0.000
9	CPU	4.000	28.800	0.000	115.200	0.000
10	Sat Com	10.200	-27.600	7.200	-281.520	73.440
11	Encrypting	3.000	-27.600	0.000	-82.800	0.000

Item	Weight (lb)	x (in)	y (in)	Mx (in-lb)	My (in-lb)
Components	768.110	0.119	-0.039	91.066	-30.240
40%	307.244	0.000	0.000	0.000	0.000
7.38 Gal Fuel	53.780	0.000	0.000	0.000	0.000
Cargo	120.000	0.000	0.000	0.000	0.000
Vehicle	1249.134	0.073	-0.024	91.066	-30.240

Center of Gravity		
x	0.0729	in
y	-0.0242	in

2.5.4 Weights

The weight of the vehicle is the most important factor in dynamic calculations. Prediction of a vehicle's real final weight has always been a very laborious and inaccurate process. A 40% inaccuracy factor has become a reliable standard over the years in calculating weight.

Appendix C5 organizes all the Chicken Hawk's components and weights.

2.6 Avionics/Flight Controls

The electronics necessary for the "Chicken Hawk" are divided into three categories. The first is the electronics section, which is associated with the ground portion of the UHV, and the second is the avionics section for the helicopter portion. The third and final section of the electronics is the ground station. Each of the first two sections can be further divided into communication, situation awareness, and positioning categories, which are connected by the central processor. During flight the ground portion of the system houses the optical package and relays the information to the air portion via short-range radio for flight control and for further relay via satellite radio to the ground station. Following the mission profile, the two portions of the vehicle begin the mission joined. Once the vehicle has reached its destination it will use the main optical system to search for an area large enough for the craft to land and land as close to the initial coordinates as possible. The ground station can designate the pattern used for searching as either spiraling outwards in all directions or with limitations so that the craft will not enter an area enemy troops may occupy. Once the system has located a possible landing site, it will query the ground station for landing confirmation at the new coordinates. Once the system has landed, it will disengage its rotors and the ground portion will be released from its docking restraints. The ground portion will then back out of its carrier and proceed with the ground portion of the mission. During this time, it will continue to relay the information it collects from its optical array and chemical detection system to the ground station. It will also track its path with its GPS so that it has at least one reliable return path to the air portion. Once the ground mission is complete, the ground portion will return to the air portion and reenter the docking area using the main optical device for guidance. After the ground portion has been locked into position the UHV will takeoff and return to base. The following sections will examine the individual electronics and avionics packages, discuss their limitations, and also examine the software needed to utilize the abilities of the system. The major hardware components are broken up into the various subsystems visually in Appendix C6.

2.6.1 Avionics (Air)

2.6.1.1 CPU

The most important portion of the avionics package is the computer or CPU (Central Processing Unit), which controls the flight and all other functions of the aircraft. The CPU used will consist of two processors working in tandem so that a level of redundancy exists within the aircraft. The CPU to be used is a scaled down version of the MACC (Multi-Application Control Computer). The MACC can be monitored and controlled by a remote ground station and is capable of processing the inputs from 50,000 sensor sets. The MACC is currently used in aircraft for flight control, vehicle management system control, and actuator/subsystem control (<http://www.aerospaceweb.org> accessed 8 April 2002).

2.6.1.2. MIAG

The Modular Integrated Avionics Group/Navigation Sensor Unit (MIAG) is an avionics package specifically designed for UAV's. The MIAG utilizes a GPS receiver for pre-programmed aircraft navigation as well as general aircraft position data. In addition, several air data pressure transducers supply the flight computer with necessary air speeds and altitudes. The unit also contains an engine command and control system. The MIAG has a built in IFF system and a fiber optic inertial measurement unit to assist in attitude and heading references (<http://www.aerospaceweb.org> accessed 8 April 2002).

2.6.1.3 Radio

The air portion of the UAV has two independent radio systems. The first is a simple short-range radio used for communication with the ground portion. The second is a satellite radio for BLOS communication with the ground station (Sadiku 2001).

2.6.1.4 Encryption

To insure security of all data transmitted by the air portion of the UHV an encryption device has been included. The device is like other encryption devices used today. It will have to be keyed at the beginning of the mission, and both the ground portion and ground station will have to be keyed with the same key for successful communication with the air portion.

2.6.1.5 Weather

The air portion of the UHV contains a certain amount of weather detection capability. This package contains basic meteorological measurement devices so that accurate conclusions about the weather conditions at the air portion can be found at the ground station.

2.6.2 Electronics (Ground)

2.6.2.1 CPU

Similarly to the air portion, the CPU is the most important portion of the ground electronics. The computer used in the ground portion is also composed of multiple processors. The processing power required by the ground portion is less than that of the air portion so a less sophisticated system is needed.

2.6.2.2. GPS

For positioning data the ground portion uses a simple GPS to keep track of its location. It stores the path it travels within the ground portion and relays it to the ground station so that it has one known secure return path to the air portion.

2.6.2.3. Radio

The ground portion of the UAV also contains two independent radios. During flight a single short-range radio system is used to communicate optical information to the air portion for flight control. For communication with the ground station, a satellite radio is used during the ground mission. The satellite radio is used for BLOS communication purposes.

2.6.2.4 Encryption

To insure security of all data transmitted by the ground portion of the UHV an encryption device has been included. It is identical to the device used in the air portion and must be keyed if the ground portion is to communicate with the other elements of the system.

2.6.2.5. FLIR

The main optical element within the UHV is a FLIR device. It operates in the 5-8 micrometer range and is coupled with an infrared pulsing LED (Light Emitting Diode). The system operates similar to a radar system during flight. The LED sends out a modulated infrared signal that is detected by the FLIR so that the range of objects can be found (Sadiku 2001). FLIR systems have the ability to operate during day, night, and low illumination circumstances. The system to be used would be similar to the Ultra 7500 FLIR system produced by FLIR Systems, Inc. (<http://www.flir.com/airborne/products/index.htm> accessed 19 April 2002).

2.6.2.6. Chemical

The ground portion of the UHV contains a chemical detection system. The system will notify the ground station if any hazardous chemicals have been in the vicinity of the ground portion. The system will be created using minute acoustic wave sensors currently being developed by Sandia National Laboratories (<http://www.sandia.gov/media/acoustic.htm> accessed 8 April 2002).

2.6.3 Ground Station

The ground station of the UHV will be the only method of communicating with the vehicle while the mission is in progress. The ground station will have the following components: a laptop type computer interface, an encryption device that will need to be keyed to the same encryption as the air and ground sections, a satellite radio for communication with the vehicle during the mission, and a serial port interface for direct transference of information with the vehicle before and after missions. The ground station will have a multiple window interface to allow for easy operation. The following windows will be available for the controller to manipulate and are all updated in real-time.

2.6.3.1 Terrain

This window is a terrain map of the area and shows the current mission path of the vehicle. The destination or path of the mission can be altered using the cursor at any point during the mission. If this is done, the software will ask for confirmation before sending the changes to the vehicle. The map will be generated from known information about the area.

2.6.3.2. Vision

This window will display the current image being seen by the FLIR system. This image can be manipulated by software to alter its appearance for the operator to see the image more clearly. These changes can be made while the image is being displayed and are done within the Vision window.

2.6.3.3. Status

This window within the ground station interface will be always visible on the right portion of the screen. This window will inform the operator of the status of the system. This includes the temperature of the different avionics and electronics elements, the amount of fuel and the rate of fuel consumption, and chemical and weather alerts that can open the weather and chemical windows.

2.6.3.4. Weather

The weather window is activated from the status window. It displays the meteorological data being collected by the weather package within the air portion and makes rudimentary predictions about the current and future weather patterns based on the typical climate of the area during the current season.

2.6.3.5. Chemical

The chemical window is activated from the status window. It displays any chemical threats that have been detected by the chemical detector and the coordinate of the encounter. Once the chemical detection system has been alerted to a possible threat, the UHV will not return to the launch point until the ground portion has sent approval. This is in addition to the normal landing query that is sent to the ground station.

2.6.3.6. Threat

This window is activated when the UHV sees an object that might constitute a threat to the vehicle. This includes enemy troops and vehicles. The system will inform the ground station of the shape of the object and its position relative to the craft, and the ground station will compare this information and inform the operator of what the object might be.

2.6.3.7. Mission

The mission window displays all data collected by the vehicle during the mission. This includes the locations of chemicals and enemy units as well as more accurate elevation readings and obstacles encountered during the mission.

2.6.4. Software

The most important aspect of the "Chicken Hawk" is the software it uses. These programs will determine what is necessary to continue flight and how to detect enemy units.

2.6.4.1. Air

- Control – This portion of the software will maintain the stability of the system during flight.
- Destination – This software will include route finding and decision making for getting to and choosing a landing site.
- Obstacle Avoidance – Recognition and avoidance of obstacles will be done by this portion of the software using the data supplied by the FLIR system.
- Weather Detector – This software will control the weather detector and format the data for easy transmission to the ground station.

- Mission Profile – Software designated, as “Mission Profile” will control what the craft will be doing, i.e. returning for another ground unit or waiting for the current unit to return.

2.6.4.2. Ground

- Control – This portion of the ground software package will control the electric motors for steering and speed.
- Enemy Recognition – This software package is one of the most important of the system for survivability concerns. This software will utilize edge detection filters on the FLIR data to recognize simple geometric shapes that may be enemy units. In addition, a database of enemy unit shapes can be uploaded to the system so that a comparison of shapes in the field can be made with these templates for recognition purposes.
- Destination – The destination software makes all decisions concerning how to get to the destination from the landing site.
- Obstacle Avoidance – Like the air portion, this software will detect and avoid obstacles within the vehicles path using FLIR data.
- Chemical Detector – This software will control the chemical detector and format the data for easy transmission to the ground station.

2.6.4.3 Ground Station

- Visual Mapping – This portion of the software will take the information transmitted from the ground portion and construct an image for the operator to use.
- User Friendly Interface – This software renders the windows discussed above in the ground station section.
- Map Database – This is a digital mapping of the world that can be downloaded to the ground station and then uploaded to the UHV.
- System Diagnostics – This is a real-time depiction of the current readings sensors within the system. These sensors include all the positioning data as well as gas level, component temperature, shaft speed, and oil pressure.

2.7 Mission Simulation

The purpose of mission simulation is to ensure that the vehicle can meet the requirements set forth in the CDD. In addition, for this application, it is the job of mission simulation to determine the fuel requirements. Presented is a logical, step through of how the fuel requirements were determined. How the vehicle meets the requirements of the CDD is discussed throughout this document.

Simulation takes a complex situation and simplifies it into a more convenient form. The purpose of simulation is to explore the various outputs in order to understand the system (Dieter 2000). In this case the complex situation is the basic mission profile given by the customer. It has been simplified into the Excel spreadsheet shown in Table 10. Various

mission profiles and fuel requirements have been explored in order to understand exactly how this system will perform.

Table 10 Power Requirements for the Flight Phases

Flight Phase	Horse Power Requirements	% Engine Power
Hover/Land	116	77
Climb (VROC 500 fpm)	146	97
Efficient Cruise (46 mph)	82	55
Cruise Speed (30 km/hr)	91	61
Warm up/Idle	91	61

The first step in starting the iteration process of the fuel requirements is to take input power requirements from all sources that will be using the engine. In this case the only source using power from the engine is the UAV. Therefore the power requirement for the rotors is required from the aerodynamics discipline. Table 10 shows the power requirements given for the fuel requirement calculations. All engine power percentages are based on 90% of the engine maximum power as required by the CDD.

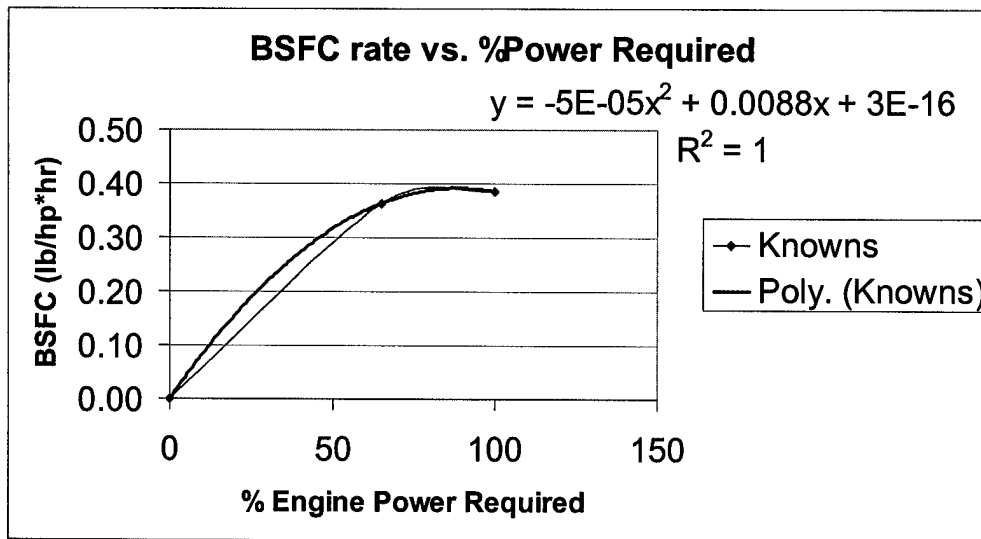

Figure 21 BSFC Rate for Chosen Engine Versus Aerial Power Requirements

These values were then inputted into the Excel spreadsheet shown in Table 11. Based on the engine chosen, the BSFC for each of the power requirements was determined by using a polynomial curve fit through the three known points given. This curve fit is shown in Figure 21. The Excel spreadsheet utilizes the basic equation shown in Equation 7.

$$FuelUsed = (BSFC)\Delta Time \quad \text{Equation 7}$$

Equation 7 is also used to calculate the corresponding BSFC for the power requirements for each flight phase and the mass of fuel used in the corresponding time for each flight phase .

In order to determine the volume that this fuel takes it was required to determine the density of the fuel required by the engine. The engine chosen is capable of using Diesel #2, JP-4, and Jet-A. In order to meet the heavy fuel requirements, the fuel chosen for this application is Diesel #2. It was determined that the density of Diesel #2 is approximately 7.079 lb/gallon.

Table 11 Excel Spreadsheet to Determine Fuel Requirements

MISSION SIMULATION - UHV DESIGN

Start from 4000 ft VROC 500 152.4
 Alt 250 76.2

BASELINE MISSION PROFILE FUEL (lb/gallon) diesel 7.079 Fuel Used

SEGMENT #	DESCRIPTION	TIME (min)	Time (hr)	DISTANCE (Km)	AIR SPEED (Km/hr)	%Required Power	FCR (lb/hr)	(lb)	(gallon)	FCR (gallon/hr)
1	WARM UP/IDLE	5	0.08	0	0	61	22.61	1.88	0.27	3.19
2	HOVER	2	0.03	0	0	86	43.87	1.46	0.21	6.20
3	CLIMB	0.5	0.01	0.08	9.14	108	68.39	0.57	0.08	9.66
4	CRUISE	30	0.5	15	30	61	22.61	11.31	1.60	3.19
5	DESCENT	0.5	0.01	0.08	9.14	61	22.61	0.19	0.03	3.19
6	HOVER/LAND	2	0.03	0	0	86	43.87	1.46	0.21	6.20
7	GROUND (idle)	120	2							
8	WARM UP/IDLE	5	0.08	0	0	61	22.61	1.88	0.27	3.19
9	HOVER	2	0.03	0	0	86	43.87	1.46	0.21	6.20
10	CLIMB	0.5	0.01	0.08	9.14	108	68.39	0.57	0.08	9.66
11	CRUISE	30	0.5	15	30	61	22.61	11.31	1.60	3.19
12	DESCENT	0.5	0.01	0.08	9.14	61	22.61	0.19	0.03	3.19
13	HOVER/LAND	2	0.03	0	0	86	43.87	1.46	0.21	6.20
	air minimum requirement cruise	0.01	0.67	20.1	30	61	22.61	15.15	2.14	3.19
	FUEL RESERVE	~10%						4.89	0.477	
							TOTAL FUEL USED	53.78	lbs	
	TOTAL DISTANCE (Km)	50.4						7.38	gallons	
	TOTAL TIME (MIN)	200								
	TOTAL TIME (HR)	4.00								

Using this information and the information gathered from the Aerodynamics and Propulsion Functions the fuel requirements for the Baseline Mission Profile were determined. In addition, the fuel requirements for alternative missions were calculated. All of this information is shown in Table 12. Based on the calculated fuel requirements the, UHV design uses a 20-gallon fuel tank. However, it will depend on the intended mission how much fuel is used. It is possible to increase the payload amount by reducing the amount of fuel used. Theoretically, if only the Baseline Mission is performed, it is possible to increase the payload amount by 74 lbs, creating a total payload mass of 134 lbs.

Table 12 Fuel Requirements

Mission Profile	Fuel Requirements Mass (lbs)	Fuel Requirements Volume (gallons)
Baseline	53.78	7.38
Idle during Ground	64.34	8.9
Hover during Ground	146.44	20.45
Cruise during Ground	102.01	14.17
Maximum Design	141.53	20

2.8 Technical Summary

Each of the technical areas has been addressed. The major problems have been identified as well as their solutions. The technical details have addressed both how they meet the CDD as well as how they contribute to the vehicle as a whole. The different subsystems were integrated as described in Section 2.1. Programmatic issues are discussed in the following section. A summary of the weight budgeting is shown in Table 12. A more discretized table can be found in Appendix C4. Table 13 summarizes technical information, and Figure 22 is a cross sectional drawing of the Chicken Hawk.

The only technical decision that was studied was the use of a coaxial rotor system instead of the single rotor with a counter torque tail. An extensive trade off analysis was performed, both technically and programmatically. Technical results are shown in Appendix C2. Though a coaxial system requires less power through most flight regimes, the ultimate decision was to stay with the single rotor system. This type of system has been proven in combat for many years. There are several commercial transmissions that could be purchased today that would need very little adjusting to meet our requirements. The transmission weight would be approximately the same for both systems. However, when one looks at all the aspects in a system wide view, the single rotor has the cheapest, most reliable, and quick development timeline of the two options. A recommendation is made in Section 6 to address future concerns.

Table 13 Weight Breakdown for the Chicken Hawk

IPT Weight Breakdown Categories (units in lbs)

UHV	-	-	-	-
1. Air drive system:				
o engine/motor	185			
o transmission	118			
o rotors	68			
o other	8.8			
- Subtotal		371	-	-
2. Ground Drive system	-	-	-	-
o batteries	129.36			
o motors	39.68			
o mode (treads/wheels),	32			
o other	44.09			
- Subtotal		245	-	-
3. Avionics and Sensor weight	-	-	-	-
o avionics	57.8			
o sensors	56			
o power sources	16.17			
o other	33.2			
- Subtotal		163	-	-
4. Structural Weight	-	-	-	-
o frame	52.18			
o skin	16			
o other	0			
- subtotal		69	-	-
5. UHV Subtotal	-	-	768	-
o Weight Contingency (40%)		307	-	-
UHV DRY WEIGHT	-	-		1075
6. Mission-Dependent Weights (max)	-	-	-	-
o Max Payload Weight	120			
o Max Optional Sensors	40			
o Max Fuel Load	53.78			
- Subtotal		1249	-	-
UHV MAX GROSS TAKEOFF WEIGHT	-	-	-	1249
7. Support and Handling Equipment	-	-	-	-
o Ground Station	25			
o Shipping Container/ Palate/straps	67			
o Test and Measurement Equipment	10			
o Spare Parts /Tools	50			
o Additional Mission-Dependent Sensors				
- Subtotal		1402	-	-
UHV SYSTEM SHIPPING WEIGHT	-	-	-	1402
	-	-	-	

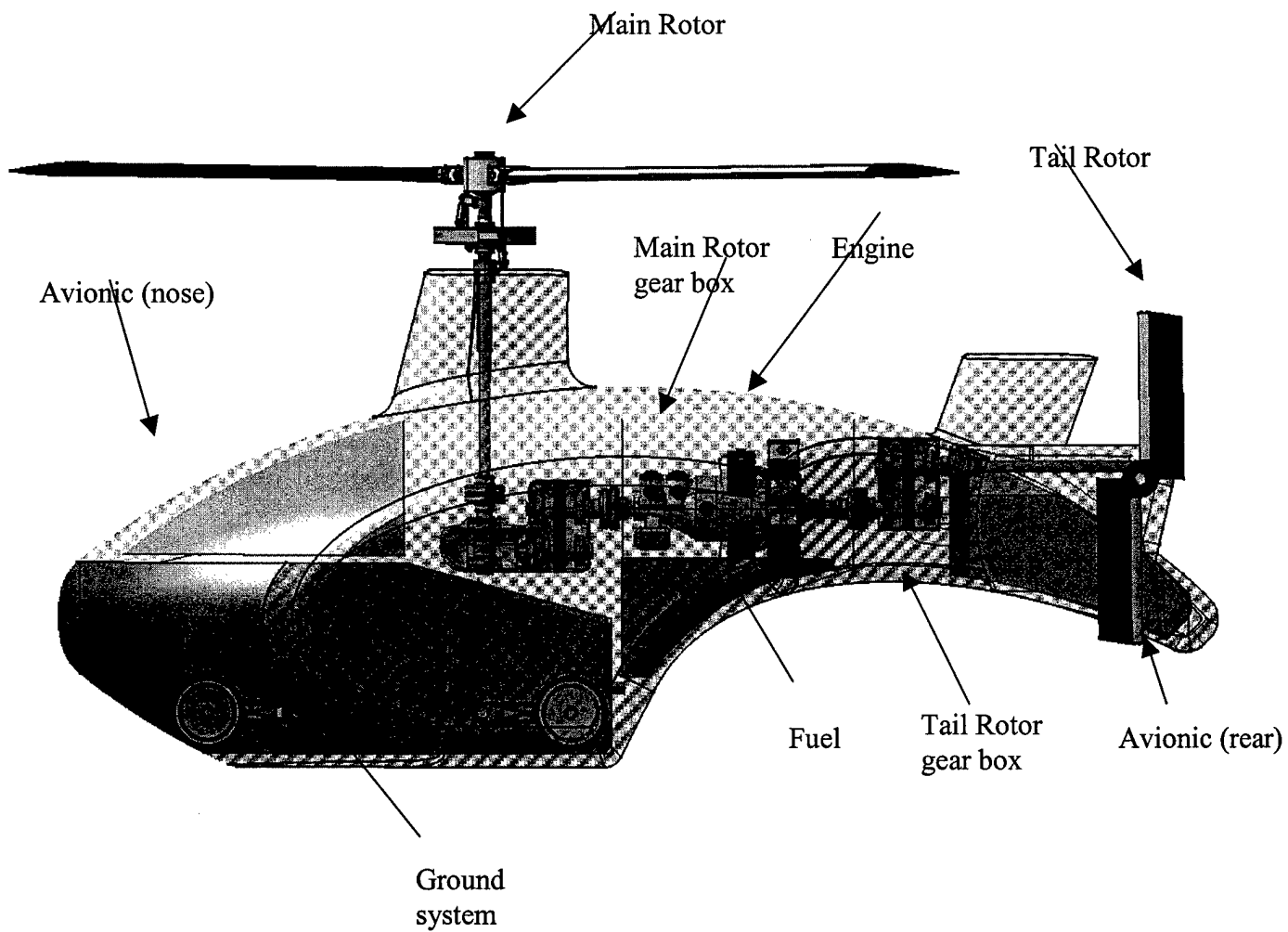

Figure 21 Cross Sectional Drawing

Table 14 Concepts Technical Information

Comparison Criteria	Chicken Hawk
Overall Specifications	
Air Configuration	Single Rotor with tail
Ground Configuration	4 wheel vehicle
Payload Mass, kg (lb)	54.44 kg (120 lbs)
Gross Takeoff Weight, kg (lb)	566.5 kg (1249 lbs)
Aero Propulsion Type	Single Rotor
Energy Source for Air Transport	Diesel Engine
Ground Propulsion Type	Electric
Energy Source for Ground Transport	Batteries
Hovering Power, Kw (hp)	102.5 kW (137.5 hp)
Cruise Power, Kw, (hp)	61.9 kW (83 hp)
Basis of Autonomous Control	Internal CPU
Primary BLOS Method	Satellite Radio
Primary Navigation Method	GPS
Primary Sensor Type	FLIR Camera
Chemical/Biological Sensor	Acoustic Wave Sensors
Method of Sling Attachment	Points at main rotor hub and vehicle base (4)
Method of Deploying Payload at range	Manual Access through Door
Enabling Technology	Existing Technolgies
Overall Dimensions, Stored, mxmxm (ftxftxft)	1.28x2.16x2.23 (4.2x7.1x7.3)

3.0 Implementation Issues

Programmatic is responsible for developing a project plan and acquisition strategy for the entire life cycle of the program. Phoenix Technologies has created a Program Work Breakdown Structure (WBS), estimated a life cycle schedule from concept to disposal, and estimated a cost for the entire life cycle. Uncertainty and risks were also considered when developing the project plan. An integrated program management array will need to be developed, listing the component elements of the WBS, along with associated costs, scheduling risks and resources (McInnis 2002).

Constructing a schedule and cost estimate is typically viewed as a technical activity. However, developing a project plan for a complicated system is mostly an art, requiring lots of intuition, judgment and guesswork.

3.1 Programmatic Ground Rules and Assumptions

In the past, UAV's have been developed for Department of Defense (DoD) use through contractor initiatives, defense acquisition programs, and Advanced Concept Technology Demonstrations (ACTD's). Due to the Initial Operational capability (IOC) being scheduled for 2012, it will be necessary to use an accelerated acquisition program. This will allow for shorter timelines and lessened oversight requirements. The acquisition program put into effect will be based on the New DoD 5000 Model, but will not be subjected to all statutory and regulatory requirements.

Operating and Support (O&S) costs typically constitute a major portion of a system's life cycle costs and therefore are critical to the evaluation of acquisition alternatives. The Chicken Hawk will be used to provide close range RISTA. One UHV system consists of three vehicles.

Eventually, four systems will be delivered to each of the Army's current 10 divisions. Three will be deployed to the direct support companies and one to the general support company of the Military Intelligence battalion. This will result in at least 40 systems being deployed at peak operational capability.

AMCOM has requested 300 total UHV's to be produced. Two additional units will be produced as prototypes. Approximately 26% of the 300 units will be classified as spares. The number of spares is based on historical attrition rates.

Associated with past UAV programs, a portion of the spares may be stored in sealed containers for up to 10 years and placed in strategic locations for use in rapid response situations (<http://www.au.af.mil/au/2025/volume3/chap13/v3c13-1.htm>, accessed 26 March 2002).

Phoenix Technologies plans on taking advantage of the US Army's initiative to fund these technologies.

3.2 Work Breakdown Structure

A Program WBS was developed using the Department of Defense Handbook Work Breakdown Structure as a guide as shown in Figure 23 (http://acq.osd.mil/pm/newpolicy/wbs/mil_hdbk_881/mil_hdbk_881.htm accessed 7 March 2002). The WBS is an outline describing all of the work that must be completed, breaking it into categories.

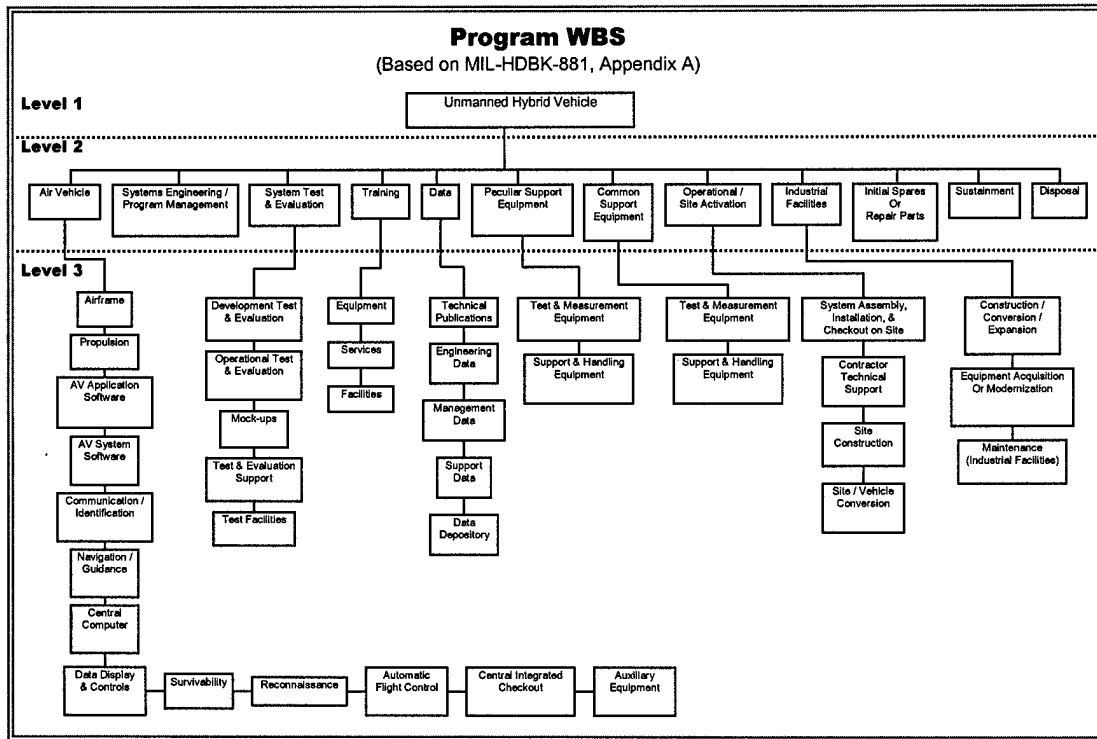

Figure 22 Program Work Breakdown Structure

3.3 Life Cycle Schedule

The projected life cycle for this program began with concept exploration in FY 2002 and is projected to continue until disposal sometime in FY 2030. This timeline was determined by establishing IOC to occur during FY 2012 and assuming a program life expectancy of approximately 20 years as is customary for Army programs.

Activity	FY02	FY03	FY04	FY05	FY06	FY07	FY08	FY09	FY10	FY11	FY12	FY13	FY14	FY15	FY16	FY17	FY18	FY19	FY20	---	FY30	
Phase 0 Concept Exploration					■																	
Milestone A	MS	△																				
Phase I Concept & Technical Development		■	■	■	■																	
Milestone B	MS B	△																				
Phase II System Development & Demonstration		■																				
Milestone C	MS C	△																				
Phase III Production		■	■	■	■	■	■	■	■	■	■	■	■	■	■	■	■	■	■	■	■	■
LRIP	LRIP	▽																				
IOC	IOC	▽																				
Deployment		■	■	■	■	■	■	■	■	■	■	■	■	■	■	■	■	■	■	■	■	■
Disposal		■																				

Figure 23 Overall Technology Development Schedule

As shown in Figure 24, Phoenix Technologies would start contract negotiations in December of 2002. Further refinement of the design, as all parts are commercial off the shelf items, would last until 2004. Two years are then given for manufacturing of a single prototype or a limited first run of vehicles based upon contract demands. Starting in 2006 and running through 2007 will be testing and redesigning after prototype testing to make sure all of the "bugs" are worked out of the system. In 2008 a full manufacturing run will begin, with units

in the field starting in 2012. Manufacturing would run until around 2025 and disposal would begin in 2030.

3.4 Life Cycle Costs

The total life cycle cost for one UHV was estimated to be \$7,200,000. This was determined using an informal rule based on historical experience. A figure of \$1500 per pound (based on FY94 dollars) was adjusted for inflation for FY02 to be approximately \$1800 per pound. The Chicken Hawk's weight as a combined unit is 1075.35 lbs, not including fuel and cargo, which results in a production cost of \$1,935,630 per unit. This cost was then multiplied by the 300 units, requested by the customer, in order to determine the production cost for the entire program. This resulted in an estimated cost of \$580,689,000 for the total life cycle of the program.

Table 15 lists the breakdown of total life cycle cost for the vehicle. Also shown is the estimated total cost per unit. The total cost was broken down as follows. Ten percent of the total cost was assumed to be Research, Development, Test, and Evaluation (RDT&E), twenty-five percent was assumed for production, and sixty-five percent was assumed for O&S. Disposal cost typically represents a small fraction of the total life cycle cost and was therefore excluded (Gunther 2002).

Table 15 Life Cycle Cost Per Unit

Costing Phase	Percent of Total Cost	Total Program Cost (\$ FY02)	Unit Cost (\$) FY02
RDT&E	10	232,275,600	774,252
Production	25	580,689,000	1,935,630
O&S	65	1,509,791,400	5,032,638
Disposal	n/a	n/a	n/a
Total	100	2,322,756,000	7,742,520

The total estimated life cycle cost of the program, \$2,322,756,000, when evenly distributed over thirty years, results in an annual budget of approximately \$77,425,200. More funding per year may be needed during the first ten years of development and less per year during the disposal phase. A breakdown of the life cycle cost of the air and ground unit separately can be found in Appendix C7.

3.5 Risk Analysis

The primary risk associated with this project comes in the first five years of the project. Scheduling technology developments is not an exact science. The phases of this cycle can and will very likely overlap and not be constrained by the indicated schedule. After this initial cycle, the remainder of the project's life such as manufacturing, operations, and

disposal will likely follow the indicated schedule, barring discontinuance of the project at some point.

The transmission system is also considered a risk. The system can be bought off the shelf, but some aspects of the system may have to be reconfigured to work in this design. This could delay production minimally.

Due to the amount of internal logic, the vehicle must have software development extended to ensure proper vehicle function.

3.5 Discussion of Application and Feasibility

The UHV design that is eventually produced and deployed will combine the capabilities currently performed separately by UAV's and UGV's. This will reduce O&S costs significantly, by reducing the number of personnel and the amount of training currently needed to field both UAV's and UGV's. The UHV will have an advantage in certain mission areas commonly categorized as "the dull, the dirty, and the dangerous." That is, it will be able to monitor a much larger area than human sentries ("the dull") and thus become a force multiplier. It can be used to detect for nuclear, biological, or chemical contamination without risk to human life ("the dirty"). The UHV will also be capable of assuming risky missions and can be used to prosecute heavily defended targets (currently left to forces on the ground or in the air) without loss of human life ("the dangerous"). In short, the opportunities available in effectively deploying the UHV are subject only to the imagination of the commanders.

The UHV will probably cost as much to develop as current manned air and ground vehicles. However, the cost of the UHV will be significantly cheaper over the entire life cycle. This is due to the fact that personnel can be sufficiently trained with simulators, unlike currently manned vehicles where some losses occur during training. There is no threat to the personnel if the UHV is lost during a mission. This will reduce the number of crews that have to be trained as replacements, thus saving time and money.

4.0 Company Capabilities

4.1 Company Overview

Phoenix Technologies is a recently formed, diverse group of engineers who excel in many different disciplines. Based in Huntsville, AL, this group has team members from France, Canada, Puerto Rico, and various parts of the United States. This company not only has a diverse work experience but field expertise as well. By using innovative ideas to deliver cutting edge technology, this group of engineers was created to bring these engineering concepts to fruition.

Good communication skills are the key to any company's success, especially between the team leader and the rest of the team. This not only reduces the need for outside of class status meetings but also allows everyone on the team to work in their prospective disciplines in their own way. Class meetings were used to brainstorm, debate ideas, and solve problems

together. Not only has everyone in this team worked very hard in their prospective disciplines, but helped out other disciplines. This encourages a sense of unity by allowing a global view of where the project is headed.

A broad based team enables all aspects of the project to be covered. Phoenix Technologies has team members with not only with military experience but also in aerodynamics, customer interaction, simulation, manufacturing, and research. This is a well-balanced and capable group of young engineers.

This company has the ability to gather information by interacting with major industrial companies, government agencies, mentors, company websites, current textbooks, and magazines. Phoenix Technologies consists of many brilliant and dedicated individuals. It is these strengths that will allow the team to plan and build the UHV successfully.

4.2 Personnel Description

- **Ms. Jennifer Pierce-Phoenix Technologies Project Office/Programmatic**
Ms. Pierce brought many management talents to the Phoenix team. She provided support through the technical design phases while keeping the team focused on the final outcome. Her thorough knowledge of the project and the customer requirements helped avoid many complications during the design phases.
- **Mr. Brian Akins-Phoenix Technologies Systems Engineer**
Mr. Akins has an ample ability to show support for every discipline. His outgoing personality gives him the tools he needs to be able to move between every group to make sure the specification is being met and to help with technology assessment.
- **Mr. Adam Elliott-Phoenix Technologies Aerodynamics Team**
Mr. Elliott has a strong knowledge in aerodynamics, which was instrumental to the group. He worked tirelessly to formulate the most critical aspects of the design.
- **Ms. Dorothee Barre-Phoenix Technologies Propulsion Team**
Ms. Barre is a unique individual with many talents. As our primary ESTACA contact, she worked extremely hard to understand what was necessary.
- **Mr. Thomas Clerc-Phoenix Technologies Propulsion Team**
Mr. Clerc's extensive research and analysis of propulsion system enabled us to make informed decisions.
- **Mr. Samuel Gleme-Phoenix Technologies Propulsion Team**
Mr. Gleme not only contributed to the propulsion portion of the project; he also headed up the computer-modeling portion. His extensive knowledge of computer software was very helpful in this project.
- **Mr. Gregoire Berthiau-Phoenix Technologies Ground Robotics Team**

Mr. Berthiau has a very analytical mind, which allowed him to contribute greatly to the ground robotics portion. As a French student here in the US, he was greatly appreciated in helping to communicate with ESTACA.

- Mr. Patrick Damiani-Phoenix Technologies Mechanical Configuration Team
Mr. Damiani is an upbeat individual with unique talents. He has shown excitement for the technologies he is studying and has worked tirelessly to gather information from his contacts.
- Ms. Christina Davis-Phoenix Technologies Mission Simulation Team
Ms. Davis has actual experience in mission simulation from where she works. She has contributed greatly and is a very strong asset.
- Mr. Michael Burleson-Phoenix Technologies Avionics and Flight Controls Team
Mr. Burleson's extensive knowledge of Electrical Engineering helped him lead the development of the sensors and communications for the UHV. He is a great asset to the team and was very much appreciated.
- Mr. Claudio Estevez-Phoenix Technologies Avionics and Flight Controls Team
Mr. Estevez has been a valuable assistant in researching avionics technologies despite schedule conflicts that prevented his attendance at weekly meetings. Through email and telephone calls, he has played a key role in this project.

5.0 Summary and Conclusions

Future military operations require that forward reconnaissance missions be performed by automated vehicles that can perform under many conditions. These vehicles must possess stealth properties and an intelligence capability that is presently available. Phoenix Technologies has gone to great lengths to evaluate current technologies to determine the best combination available to meet AMCOM's requirements.

The concept of a separation unit is quite unorthodox but with its high efficiency performance, ease of use, and convenience, it is capable of performing multiple missions at once. Sturdy but yet lightweight materials and quiet propulsion, which uses readily available diesel or jet fuel, make this system usable in almost any environment. This UHV offers ease of maintenance while in the field. The Chicken Hawk meets the specification in every category and is an excellent candidate for future development.

6.0 Recommendations

Though the current Chicken Hawk design meets or exceeds each design requirement, it is not the optimized design. After further research and hardware testing, further improvements can be made to produce the best vehicle possible.

The single largest technical recommendation that can be made at this time would be a further trade off analysis between a single rotor concept and a coaxial system. The single rotor concept was chosen as outlined in Section 2.8. As more coaxial transmissions become

available, a second variant of the Chicken Hawk could be produced that uses a coaxial rotor. By removing the tail the system is lighter and set up will be easier in the field. The vehicle's profile will be smaller, which would reduce the radar cross-section therefore lowering detectability.

The other area where improvements could be made is in avionics. Over the development period, technology will improve the selected systems and alter their performance. The commercial FLIR systems available at this time are too large for the Chicken Hawk. The systems require much greater resolution than that required for the UHV, though are much too heavy for the size of the vehicle.

The current system for depth perception is an active element like radar in that it sends out a ping and waits for a reflection. In the near future technological advances will allow for individual troops to be outfitted with detectors for such devices. To combat this a more passive system is required. It is therefore a good idea to examine the possibility of a stereoscopic vision system for this UHV. Such a system would work in the same manner as human vision does. It would utilize two optical detectors and new software to calculate the distance to objects knowing the distance between the two imagers. In addition, if two different types of imagers were used a better quality image would result.

One final recommendation would be further research into an active sound suppression system. The technology exists for such a system today, especially since the sound produced by the UHV while flying is repetitive. If such a system could utilize this technology into a package that was both small and light enough, it could be added to the Chicken Hawk to decrease detectability.

References

Ferris, Linda. (undated) Unmanned Vehicle Technology Extends Soldiers' Capabilities and Reduces Risk. <http://www.saic.com/cover-archive/government/uav.html>. Accessed 7 April 2002).

Squeo, Anne Marie. 2001. Meet the newest recruits: robots help military detect, evade the enemy. Wall Street Journal, Dec. 14. Online at <http://www.azstarnet.com/attack/indepth/wsj-robotjeeps.html>

Aerospace America. 2002. "X-50 Dragonfly poised for takeoff," April 2002, pp. 30-34.

Anderson, J.D. 1999 "Introduction to Flight." McGraw-Hill.

Anderson, J.D., 2001 "Fundamentals of Aerodynamics." McGraw-Hill.

Barralis, J., and G. Maeder. YEAR. "Elaboration, property structures for normalization."

Benfield, P.J. 2002. Interview by Jennifer Pierce. 22 February 2002.

Berry, John. 2002. Presentation at AHS Rotorcraft Conceptual Design Symposium. Huntsville, AL. 17 January.

Carroll, John. Interview by Jennifer Pierce. 13 April 2002.

Combes, E. 2002. Interview by Samuel Glemee. 8 February 2002.

Coutrot, A. 2002. Interview by Dorothee Barre. 28 January 2002.

Dieter, George E. 2000. "Engineering Design: a Materials and Processing Approach" 3rd edition. McGraw-Hill.

Fuel Users Guide. 1997. "AR 70-12, Fuels and Lubricants Standardization Policy for Equipment Design," 1 May.

Grivel, T. 2002. Thomas Clerc. 7 February 2002.

Grover, A.J. 1998. "A Simulation Model for Predicting Unscheduled Maintenance Actions for an Unmanned Aerial Vehicle System." The University of Alabama in Huntsville.

Gunther, David. Interview by Randall Holt. 4 April 2002.

http://acq.osd.mil/pm/newpolicy/wbs/mil_hdbk_881/mil_hdbk_881.htm Accessed 7 March 2002.

<http://daimlerchrisler.be/fr/fr-dcd11.htm> Accessed 13 February 2002.

<http://imartinez.etsin.upm.es/dat1/eCombust.htm> Accessed 19 March 2002.

<http://library.cbest.chevron.com> Accessed 19 March 2002.

<http://quasiturbine.promci.qc.ca> Accessed 3 & 15 February 2002.

<http://www.aerospaceweb.org/design/ucav/avionics/shtml> Accessed 8 April 2002.

<http://www.aeroworldnet.com/1ra01137.htm>. Accessed: 21 February 2002.

<http://www.aeroworldnet.com/1ra01137.htm>. Accessed: 21 February 2002.

<http://www.au.af.mil/au/2025/volume3/chap13/v3c13-1.htm> Accessed 26 March 2002.

<http://www.azstarnet.com/attack/indepth/wsf-robotjeeps.html> Accessed 7 April 2002.

<http://www.biodiesel.com> Accessed 19 March 2002.

<http://www.biosfero.fr/biosfero.dir/hybrid.dir> Accessed 13 February 2002.

<http://www.chevron.com> Accessed 1 April 2002.

<http://www.helosim.com/coaxialarticle.htm>. Accessed: 21 February 2002.

<http://www.imperialelectric.com/cgi-bin/wspd.cgi.sh/WService=imperial/itemdrawing.html?item=137> Accessed 29 March 2002.

<http://www.MatWeb.com/> Accessed 1 April 2002.

http://www.mercedes.be/fr/news/1999/fr_9903.html Accessed 13 February 2002.

<http://www.sandia.gov/media/acoustic.htm> Accessed 8 April 2002.

http://www.toyota.fr/g/g01_02_02.html Accessed 20 February 2002.

<http://www.turbomeca-support.com> Accessed: 3 February 2002.

<http://www.zoche.de/diesels.htm> Accessed 30 March 2002.

Leishman, J.G. 1999. "Principles of Helicopter Aerodynamics". Cambridge University Press.

McKay, Joe. 2002. Presentation at AHS Rotorcraft Conceptual Design Symposium. Huntsville, AL, 17 January

Miller, Brad. Interview by author. 15 March 2002.

National Council of Examiners for Engineering and Surveying. 2000. The Fundamentals of Engineering Supplied-Reference Handbook, 4th edition. .

Sadiku, Matthew N. O. 2001. "Elements of Electromagnetics". 3rd edition. Oxford University Press.

Williams, Lew. 2002. Presentation at AHS Rotorcraft Conceptual Design Symposium. Huntsville, AL. 17 January.

Appendix A - Concept Description Document

Appendix A

Appendix A - Concept Description Document

Concept Description Document Approval

The undersigned agree that the attached Concept Description Document as marked will be the basis the UAH IPT 2002 Design Competition. From this time forward, any questions or clarifications concerning the concept description document to the Customer shall be submitted in writing and the answer distributed to all UAH IPT's in writing.

To change the Concept Description Document Prior to April 30, 2002 shall require that the change be stated in writing and that a person authorized by every one of the signers below endorse the change with their signature. The revision will be labeled uniquely and distributed to all teams simultaneously.

The original of this document will be kept on file with the UAH Project Director. All signers will receive a copy of the original document.

James P. Winkeler 12/5/02
James Winkeler, Customer

Geof Morris 102/05/2002
Geof Morris, UAH IPT 01

Dana Quick 102/05/02
Dana Quick, UAH IPT-02

Jennifer Pierce 12/5/02
Jennifer Pierce, UAH IPT 03

Robert A. Frederick, Jr. 12/5/02
Robert A. Frederick, Jr., UAH IPT 2002 Project Director

IPT
IPT2002 Concept Description Document Rev07.doc IPT2002_Concept_Description_D
ocument_Rev06
Current as of 2/5/2002

A-1
RAF
10/15

Appendix A - Concept Description Document**1. General Description of Operational Capability****1.1. Overall Mission Area**

1.1.1. The system shall be a versatile scout and pack animal for future force structures, transporting critical payloads (e.g., ammunition, medical supplies).

1.1.2. The system shall be capable for use for target recognition and definition.

1.1.3. The system shall be capable for use in terrain definition.

1.1.4. The system shall be capable for use in situational awareness.

1.1.5. The system shall be capable of at least semi-autonomous operation, with full autonomous operation desirable.

1.1.5.1. The system shall be capable of human interface as required.

1.1.6. The system shall be capable of executing both a preplanned and diverted mission profiles.

1.1.7. The system shall be capable of navigating and functioning without a payload.

1.1.8. The system shall be capable of detecting chemical and biological threats.

1.1.9. The system shall be capable of detecting adverse weather conditions.

1.2. Operational Concept

1.2.1. The system shall be capable of nap of the earth flight (below the treeline).

1.2.2. The system shall be capable of operation at a range of 15-30 km ahead of the fighting force, with a 10% fuel reserve upon return.

1.2.2.1. The system shall be capable of gathering information on threat activities at range.

1.2.2.2. The system shall be capable of enhancing the RISTA/BDA.

1.2.2.3. The system shall be capable of transmitting information via secure data links and C2 structures BLOS.

1.2.2.4. The system shall be capable of using TF/TA/GPS/INS hardware and software to define and navigate complex terrain.

1.2.2.5. The system may encompass a degree of AI, ATR, and on-board decision making.

1.2.3. Payload Requirements

1.2.3.1. The system shall be capable of carrying a payload of 60lbs required gross weight, 120lbs desired gross weight, with a minimum payload volume of 2' x 2' x 2' [8 ft³].

1.2.3.2. The system shall be capable of flying the payload to operational range in 30 minutes or less and be able to return from range in 30 minutes or less.

1.2.3.2.1. The vehicle will have a minimum cruise airspeed of 30 km/hr and a desired airspeed of 100 km/hr.

1.2.3.3 There shall be no power or data interfaces between the vehicle and the payload.

1.2.4. Mission Requirements

1.2.4.1. The system shall be capable of landing in an unprepared area with a ground slope of 12° maximum up or down.

1.2.4.1.1. The vehicle must have vertical takeoff and landing capabilities.

1.2.4.2. The system shall maximize survivability.

- 1.2.4.2.1. The system shall have a near quiet acoustic signature.
- 1.2.4.2.2. The system shall be designed for an operational altitude of 0 – 250 ft AGL required, 0-500 ft AGL desired.
- 1.2.4.2.3. The system shall be capable of a 200 fpm VROC [required], 500 fpm [desired], at 4000 ft and 95 °F, with the payload in place.
- 1.2.4.3. The system shall be designed to be transported via a HMMWV and trailer, and/or via external sling load by a UH-60 helicopter.

2. System Capabilities

- 2.1. The system shall be capable of operation at an altitude of 4000ft, 95 degrees Fahrenheit ambient temperature, and not using more than 90% maximum rated power.

2.2. Operational Performance

- 2.2.1. The system shall possess essential performance, maintenance, and physical characteristics required to operate under adverse environmental conditions worldwide, down to –40 °F.
- 2.2.2 The system shall possess essential performance, maintenance, and physical characteristics required to operate under adverse geographical conditions worldwide.
- 2.2.3. The system shall be capable of operating from any unimproved land facility surface day or night, including low illumination.
- 2.2.4. The system shall be capable of operation under and detection of battlefield obscurants.
- 2.2.5. The system shall be capable of ground operations on unimproved roads at ground speeds of 6 km/hr [required], 12 km/hr [desired] for no less than two (2) hours at a radius of 0.5 km [required], 1 km [desired].
Unimproved roads: Non-prepared surfaces, not to have more than RMS of 1", which means, over 1 ft can not rise or dip more than one inch, no linear features, which means no barriers, blocks, bricks, big rocks, etc., nothing in path of vehicle except trail or road and finally, no more grade than 12 degrees.
- 2.2.6. The system [vehicle and ground station] shall weigh no more than 1500 lbs [required], 1000 lbs [desired].
- 2.2.7. The system shall use readily available diesel or jet fuel.

2.3. The system shall possess the following electronic capabilities:

2.3.1. Mission Planning System

- 2.3.1.1. The system shall possess a point-and-click pre-mission planning system to simulate mission flight.
- 2.3.1.2. The system shall possess data loading capabilities.
- 2.3.1.3. The system shall be capable of coordination and reaction to immediate operational mission changes.
- 2.3.1.4. The system shall be capable of processing self awareness and threat sensor inputs.
- 2.3.1.5. The system shall be capable of enabling TF/TA from digital mapping information from satellite or other sources.

2.3.2. Avionics

- 2.3.2.1. Communications and navigation suite architecture shall be compatible with emerging military data links.
- 2.3.3. Communications
 - 2.3.3.1. System communications shall be robust and have clear secure modes of operation
 - 2.3.3.2. Communications shall be simultaneously LOS and BLOS which can include satellite relay or other relay system compatibility.
 - 2.3.3.3. System must possess IFF and be compliant to all FCC/military communication regulations.
 - 2.3.3.4. System must be capable of communication with and sharing digital mapping/targeting information with other DoD RISTA platforms.
- 2.3.4. Connectivity
 - 2.3.4.1. The system shall be interoperable with other DoD systems envisioned for the 2012 battlefield to the maximum extent possible and be compatible with service unique command, control, and information systems.

3.0 ACRONYM LIST

AGL	Above Ground Level
AI	Artificial Intelligence
ATR	Automatic Target Recognition
BDA	Battlefield Damage Assessment
BLOS	Beyond Line of Sight
C2	Command and Control
DoD	Department of Defense
FCC	Federal Communications Commission
fpm	feet per minute
ft	feet
GPS	Global Positioning System
HMMWV	High-Mobility, Multipurpose Wheeled Vehicle
IFF	Identify Friend or Foe
INS	Inertial Navigation System
IPT	Integrated Product Team
km	kilometers
km/hr	kilometers per hour
lbs	pounds
LOS	Line Of Sight
RISTA	Reconnaissance, Intelligence, Surveillance, Target Acquisition
RMS	Root Mean Square
TA	Terrain Avoidance
TF	Terrain Following
UAH	The University of Alabama in Huntsville
UH-60	Utility Helicopter
VROC	Vertical Rate Of Climb

Baseline Mission Profile

Critical Flight Conditions:
Altitude - 4000 ft
Temp - 95°F
VROC - 200-500 FPM

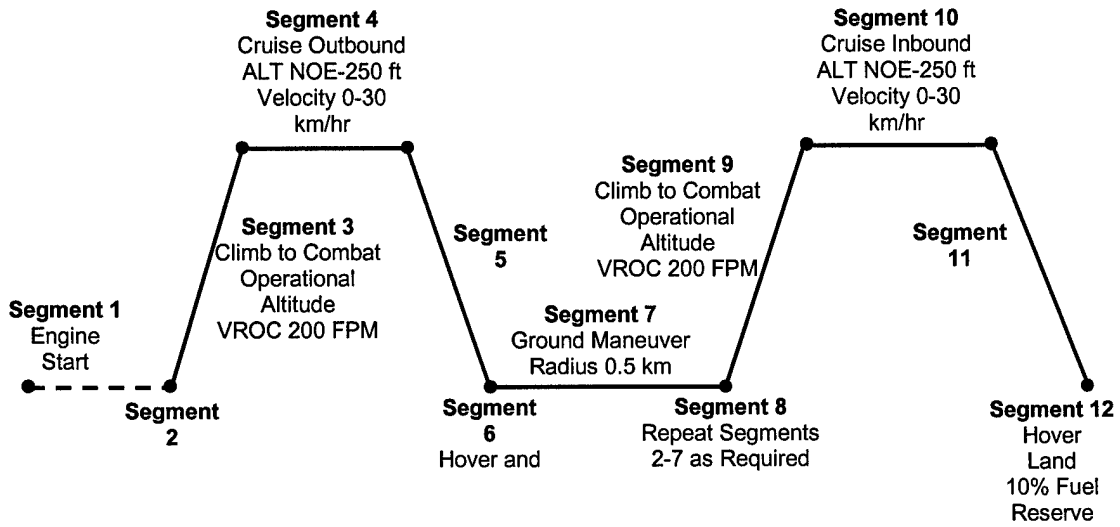

Appendix B - White Paper

Competition Sensitive Document Attached

Team 3

The Attached Document is Competition Sensitive until May 1,2002.

If you find this document and do not know what to do with it,

put it in a secure place and notify

Dr. Robert A. Frederick, Jr. at UAH

256-824-7203

frederic@eb.uah.edu

Alternate Concepts White Paper

IPT 3

Project Office:	Jennifer Pierce
Systems Engineering	Brian Akins
Aerodynamics	Adam Elliott
Propulsion and Power	Dorothee Barre; Samuel Glemee; Thomas Clerc
Ground Robotics/Vehicle	Gregoire Berthiau
Mission Simulation	Christina Davis
Mechanical Configuration/Structures	Patrick Damiani
Avionics, Sensors, Autonomous Flight Controls	Michael Burleson; Claudio Estevez
Programmatic Considerations	Jennifer Pierce

Submitted By:



March 5, 2002

Submitted To:

Dr. Robert A. Frederick
Associate Professor
Department of Mechanical and Aerospace Engineering
University of Alabama in Huntsville
frederic@eb.uah.edu
Class Web Page: <http://www.eb.uah.edu/ipt/>

Abstract

Military strategy and tactics are an important aspect of military technology. Strategy is the art and science of military command exercised to meet the enemy in combat under advantageous conditions. Tactics implement decision strategy by the movement of troops and employment of weapons on the battlefield. The development and use of the appropriate weapons is essential to strategy and tactics, and therefore the successful conduct of warfare. In today's society, tactics are changing to a more unmanned system of reconnaissance rather than risking more lives in warfare. The goal of Phoenix Technologies is to merge the already existing systems of UAV's and UGV's into an Unmanned Hybrid Vehicle by looking at existing technology. We have developed four intelligent concepts to meet the requirements set forth by the customer. The first concept is semi-autonomous, which requires little input from a human pilot, has a basic two coaxial rotor system powered by Avgas internal combustion engine. Due to such a high VROC, it's aerial power requirements are rather large and has greatly increased the size and weight of the vehicle. The second concept has a coaxial rotor system but uses a three-wheeled ground configuration. However, the high manufacturing cost and high maintenance due to the more complex transmission prevent this concept from being as viable as the others. The third concept carries two ducted fans but still using a typical internal combustion engine. To use this type of system, it will need a complex transmission and orientation system and the air components will be somewhat heavy. The fourth and final concept is a fully autonomous system that combines a separate unmanned ground unit and an unmanned aerial unit. Although this concept's disadvantage lies in logistics, it's weight and size makes this concept more feasible and is why this has been selected as the final concept.

Resumé

La tactique et la stratégie militaire sont des aspects importants de la technologie militaire. La stratégie est un art et une science du commandement militaire qui permet d'avoir un avantage sur les ennemis rencontrés au combat. La tactique met en application les décisions stratégiques par le mouvement de troupes et l'emploi d'armes sur le champ de bataille. Le développement et l'utilisation d'armes appropriées sont essentiels à la stratégie et la tactique, et par conséquent au succès de la guerre. Dans la société d'aujourd'hui, la tactique s'oriente vers des systèmes de reconnaissance moins humanisés permettant de risquer moins de vies au combat. Le rôle de Phoenix Technologie est de combiner les systèmes d'UAV (drone aérien) et d'UGV (drone terrestre) existants aujourd'hui pour en faire un UHV à l'aide des technologies existantes. Nous avons développé quatre concepts intelligents pour répondre à la demande présentée par les clients. Le premier concept est semi-autonome, il requière des entrées d'un pilote humain. Ce concept est constitué d'un système basique de rotors coaxiaux mis en mouvement à l'aide d'un moteur à combustion interne Avgas. Due à la forte VROC, la demande en puissance, assez élevée, a fait augmenter la taille et le poids du véhicule. Le second concept utilise également un système de rotors coaxiaux mais n'a que trois roues pour sa configuration au sol. Cependant le coût de fabrication et la maintenance due à une transmission complexe empêche ce concept d'être aussi viable que les autres. Le troisième concept est constitué, quant à lui, de deux hélices carénées mais utilise un système de combustion classique. Utiliser ce système, nécessitera une transmission et une orientation des hélices complexe ainsi qu'une composante aérienne lourde. Le quatrième et dernier concept est un système complètement autonome qui combine une partie au sol et une partie aérienne séparée. Bien que ce concept présente un inconvénient au niveau logistique, son poids et sa taille le rendent plus faisable et c'est donc celui-ci que nous avons sélectionné pour être le concept final.

Technical Description

1.0 Overview of Phase 2

The Unmanned Hybrid Vehicle (UHV) sought by the U.S. Army Advanced Systems Directorate is envisioned to provide essential scouting and target recognition to the Brigade Commander. The customer and all participating teams endorsed a Concept Description Document (CDD) finalizing the customer requirements for this system on February 5, 2002. Phase 1 of the project produced one baseline concept that attempted to satisfy the project (CDD) using existing technology. Phoenix Technologies at the University of Alabama in Huntsville has focused on synthesizing three alternative concepts. This White Paper provides a summary of the Baseline and our three alternative concepts. The key attributes of each concept are compared against the CDD. One of the concepts is selected for development in Phase 3.

1.1 Specification Summary

The vehicle must have a VROC of at least 200 fpm, 500 fpm desired for reasons of survivability and follow a nap of the earth profile. The operational altitude is 0-250 ft required, 0-500 ft desired above ground level.

The vehicle will be capable of carrying a payload of no less than 60 lbs and no more than 120 lbs with a minimum payload volume of 8 ft³.

The vehicle will operate at a range of 15-30 km ahead of the fighting force with a 10% fuel reserve upon return. It will be capable of flying the payload to range in 30 minutes or less and be able to return from range in 30 minutes or less.

The vehicle will be capable of at least semi-autonomous operation, with full autonomous operation desired. This will include executing a preplanned and diverted mission profile, detecting chemical and biological threats and adverse weather conditions.

The vehicle must have VTOL capabilities. This includes landing on an unimproved road with a ground slope of 12° maximum up or down. Unimproved road meaning that over 1 ft can not rise or dip more than 1 inch, no linear features, which means no barriers, blocks, bricks, big rocks, etc.

1.2 Key Challenges

Developing a UHV presents an array of technical problems. Though there are both existing UAVs and UGVs there are no systems that combine both concepts into one vehicle. To meet the requirements set forth by the customer for each system would be challenging and to combine both air and ground missions presents it's own set of difficulties. Meeting the aerial requirements would produce a rather large and powerful helicopter. Adding a system to complete the ground mission to such a vehicle makes an already heavy complex system even more complicated. The ultimate challenge lies in developing a vehicle to meet the specifications and still be deployable on the battlefield.

Using existing technology will simplify concept development though integrating these technologies may delay deployment date. Combining each system will make it difficult to meet the specification for transportable and maintain the ability to carry the specified payload.

2.0 Description of Concepts

Our approach to designing this UHV concept began with an assessment of current technology. A baseline concept was developed to not only compare its performance characteristics to the customer requirements but to determine any limitations and weaknesses. The baseline concept was then used as a platform from which to determine three additional concepts for comparison. Our approach for determining the alternative concepts involved creating new ways of accomplishing the mission and then selecting existing technology to meet those demands. After reviewing all of the new concepts, the field was narrowed to three: a coaxial, three-wheeled system, a ducted fan system, and a separate air and ground vehicle. We were able to do a preliminary evaluation to choose the best one. In the next phase, this final concept will then be more adjusted and refined

2.1 Baseline Concept "Rolling Feather"

The "Rolling Feather", shown in Figure 1 of section 5.0, is designed to be a semi-autonomous hybrid reconnaissance vehicle. That is it is designed to have both ground and aerial capabilities with little input from a human pilot. This vehicle is able to detect chemical/biological threats, deliver critical cargo, recognize targets, differentiate between targets, define terrain, and perform communication/data relay. This vehicle operates between 15 and 30 km in front of the fighting force, therefore it can relay important information to the fighting force about the situation it is approaching.

This concept has an approximate gross weight of approximately 1100 pounds. This includes a payload weight of 60 pounds located under the vehicle chassis at the point mass center of gravity. The aerial portion of this vehicle consists of two coaxial counter-rotating blades powered by an Avgas internal combustion engine. The vertical rate of climb is 1000 fpm with an operation altitude of 0-250 ft AGL and the aerial cruise speed is 30 km/h with a range of 15km. The ground portion of this vehicle consists of four wheels each separately powered with its own electric motor. The electric motors are powered from batteries, which are charged by an alternator during vehicle flight. The ground speed is 6 km/h with a range radius of 0.5 km. The entire vehicle should be controlled by a gyro/inertial package plus sensors strategically located around the vehicle body. Ground radio, Satcom, Data encrypting, GPS, and Antenna should be used to perform necessary communications for proper function of the vehicle.

The "Rolling Feather" at the time of the Baseline Review, met all of the system requirements set forth by the customer. However, the large vertical rate of climb forced the aerial power requirements to be rather large, which in turn increases the internal combustion engine size and weight. By reducing the vertical rate of climb the aerial power is reduced which reduces the weight of the entire vehicle. This issue was addressed at the Baseline Review and since then the vertical rate of climb has been reduced to 200 fpm. This caused a revision of the Concept Description Document. Based on the revised Concept Description Document (CDD), this concept meets all requirements except the requirement for heavy fuels. This concept uses Avgas, which is not an easily obtainable fuel in the field. Because of this further research into alternative concepts is required.

2.2 Concept 3A "The Weasel"

This concept features a coaxial rotor system and a three-wheeled ground configuration as shown in Figure 2 in section 5.0. This rotor system will minimize overall size of the vehicle due to the omission of a tail for control. The coaxial system is more efficient than a standard helicopter configuration. The vehicles three-wheeled configuration will meet the terrain and slope requirements while reducing the weight of the aircraft. These benefits coupled together will yield a system with a smaller size and weight.

This aircraft features two subsystems that are unique to the other concepts. First, this aircraft will feature a more complex transmission as compared to a standard helicopter. The transmission must convert the power from the engine into power for two rotors. This power must be distributed via two counter rotating shafts. The flight system suffers from the use of the coaxial system due to the complexity and weight.

Operation of this vehicle will involve several key tasks. These tasks include takeoff, hovering, and landing. The mission will begin by receiving the its mission profile. Next, the aircraft will be prepped for flight (fueling, system checks, etc.). Then, the engine will be started and a warm up period will be completed. Following the warm up, the power will be increased to the rotors, and the aircraft will perform a vertical takeoff. Next, the aircraft will climb to altitude and begin cruising toward its destination. Upon arrival at the landing site, the aircraft will enter a landing sequence beginning with hover. Then, the aircraft will reduce power and gently touch down. At this point, the engine will be shutdown and the ground mission will begin. Movement on the ground will be provided by two electric motors driven by batteries. These motors will drive the two rear wheels. After the ground mission has been completed, the vehicle will move to the desired location and begin a main engine startup sequence. Following warm up, the aircraft will perform a vertical takeoff, climb to altitude, and cruise home. Upon arrival at the home base, the vehicle will hover and land.

There are many advantages to having this type of system. Its lack of a tail rotor and the power, which that would require, which is a good choice for hovering platforms and forward flight. The absence of an anti-torque rotor (the tail rotor) means better survivability. A great benefit of this sort of layout is that of the small size of the system, which also means a reduction of visual signature and a smaller target. It would have a reduced audio signature. A tail rotor has the problem of, due to its small size, high rotational speed and subsequently operated close to the transonic region. This has the effect of producing a great deal of noise. This aircraft also features a **Solar Model T62T-2A1** Titan Gas Turbine Engine. This engine features a single stage centrifugal compressor, annular combustor, and a single stage turbine. This engine can provide 95 hp and operate on gasoline, kerosene, and JP-4. There are also many disadvantages of this type of system. High manufacturing cost and added complexities for the control system. The issue of maintenance in accessing large portions of the gear to replace if damaged. It would also add weight and complexity of main gear drive. To drive a counter-rotating configuration takes much more robust drive gear over the gearing to drive the tail rotor.

2.3 Concept 3B "The Womprat"

The second alternative studied involves some different concepts from the Weasel and the Rolling Feather. This design, called the Womprat, as shown in Figure 3 in Section 5.0, is powered during the air portion of the mission by two ducted fans as opposed to a traditional rotor disk. The fans are driven by an Allison Model T63-A-700 (250-C18) Gas Turbine Engine. This engine provides ample power as well as requiring only a 2-to-1 gearing ratio as the fans will need to spin very fast. It also uses heavy fuel, either JP-4 or JP-5. The fans will operate in a fashion similar to a tilt rotor system; they will direct thrust downwards to liftoff and then the fan housings will rotate to allow the transition into forward flight. Once the landing area is reached the vehicle will land and proceed with the ground mission. The vehicle will travel on a set of wheels, which will not be powered. As the ducted fans can be tilted, they will rotate into a position that will permit them to provide the force needed to move the vehicle on the ground. The wheels in essence will be free to rotate and will not be powered. By using the fans for ground propulsion, there is no need for a separate drive system. The wheels will have independently controlled brakes for stopping and turning assistance. All sensor packages, navigation and control systems will be similar to the baseline configuration.

There are several advantages that this concept owns compared to the others. First of all, the vehicle will be somewhat compact; indeed its air motion system will be done with ducted fans, which do not require a large rotor span. This compact profile would allow it to land and to move on narrow roads that the other concept vehicle may not be able to traverse. This compactness also permits to the vehicle to be easily transportable. Another advantage is that on the ground the ducted fans will act as the ground system for propulsion and motion. Indeed, by turning the fans on the horizontal they will provide the power required, leaving only the need for a steering system, which will be neither heavy nor complex. By eliminating the need for the ground drive system the overall system will be simpler and lighter.

There are, however, several disadvantages associated with this concept. First, the ducted fan system will need a complex transmission and orientation system, moreover the air components will be somewhat heavy. Furthermore, since the fans are producing both the lift and the thrust, the power required will be very high. Also, high fuel consumption is associated to ducted fans as the engine will be larger to accommodate the high power needs. The fuel load required will also be large as the engine will have to run the entire length of the mission, though at a lower level while on the ground. Finally, the ducted fans are loud, and they will certainly pick up excessive dust and debris on the ground, which might give away the vehicle position.

2.4 Concept 3C "The Chicken Hawk"

The Chicken Hawk, as shown in Figure 4 in Section 5.0, is a fully autonomous system that combines a separate unmanned ground unit into an unmanned helicopter. This allows the UHV to fly to its destination and separate from the ground unit. The ground unit then continues with the ground portion of the mission without the burden of the aerial or propulsion systems.

The aerial unit of the Chicken Hawk uses a single rotor with a counter-torque tail rotor. The tail folds for transport via HMMWV trailer and UH-60 sling. The propulsion system runs off of a diesel internal combustion engine. The aerial unit has a Global Positioning System (GPS), an avionics inertial package and a radar altimeter for aerial positioning. It also has the capability to send and receive data to and from the ground unit via short wave radio, and to communicate with home base via encrypted satellite communications. The aerial unit will have the ability to return home with or without the ground unit.

The ground unit of the Chicken Hawk is a four-wheeled electrically driven vehicle. It contains a Forward Looking Infrared Radiometer (FLIR) system, a biological/chemical detection system, and the cargo. It also has a separate GPS for ground positioning. The ground unit communicates with the aerial unit via short wave radio and does not communicate with home base directly, but through the aerial unit's relay. The FLIR and biological/chemical detection system will be usable by the UHV as a whole when combined together. Electric batteries that are charged by the aerial unit when docked provide the power for the ground system.

The advantage of this concept is in its ground portion. Because the ground system is separate from the aerial system, the power required to perform the ground mission is much less. This allows the sizing of the electric motors to be less. This also lowers the overall weight of the system, which improves aerial performance. The ground unit can maneuver more easily and be less detectable, because the ground unit is much smaller than the aerial unit, and it does not possess large rotor blades. It can move faster and perform its job better than a more robust system with blades. This design concept could also allow the aerial unit to perform other mission objectives, like communication relay or aerial surveillance, while the ground mission is being performed.

The disadvantage to this concept is in logistics. Because the ground portion is a separate unit, it requires some time to dock and undock from the aerial unit. Because the ground unit does not have the capability to quickly take to flight, this could also be hazardous in certain tactical situations. If the ground unit is lost, the aerial unit can still return home, but if the aerial system is lost, the ground unit will not have the power to return on its own.

3.0 Selection of Final Concept

An evaluation matrix, which is located in Table 1, was used to compare the three different concepts. Rather than compare the baseline and the three alternative concepts to the spec, each of the alternative concepts was compared to the Baseline Design. The Baseline was used as the standard and each of the attributes were judged as being either better, about the same, or worse than the baseline. These scores were indicated by a plus (+), blank space (), or a minus (-) respectively. Using a controlled convergence method, the Chicken Hawk scored highest overall. It meets all critical requirements such as VROC, range, payload, air and ground speed, and ability to execute the flight profile, all the while performing as good or better than the Baseline.

Though more complicated, the Chicken Hawk concept has the most potential for development. Since the gross weight of the vehicle was lowest for this concept, the power requirements are much less as is the overall size. Due to the Chicken Hawk's ability of meeting or exceeding the customer requirements and it's adaptability to various missions and payloads the Chicken Hawk potential to be an extremely valuable to the future ground forces.

4.0 Phase 3 Plan

4.1 Key Issues to Address

Major issues surrounding the development of the selected concept include developing a reliable docking system for the ground vehicle. This system must be robust and easy to maintain. This entire vehicle and the docking system will require testing to verify its function and increase confidence in the design. Funding for this testing must be estimated in Phase 3 and allocated during a budgeting session. A test site must be acquired for mock missions. These missions should include a near realistic scenario so that any concerns with its operation can be addressed.

The major avionics concerns stem from the BLOS requirement. When working beyond line of sight a satellite relay is needed for the UHV to communicate with its ground station. The added delay caused by this relay prevents there being a pilot from remote controlling the UHVs flight from the ground. This leads to a fully autonomous system that must fly nap of the earth. This nap of the earth requirement means a complicated detection and avoidance system must be in place to prevent accidents. Another concern is the requirement for a chemical and biological detection system to be a permanent fixture on the craft. Such systems are extremely heavy and require a lot of power to function at any reasonable range.

4.2 Phase 3 Schedule

The next phase of the project will entail refining the design details as well as performing cost analysis and mission simulations to finalize this project. Technological challenges will be addressed to produce the best overall design. All of this research will be combined to present the most technologically advanced yet practical design both for cost and production.

5.0 Illustrations

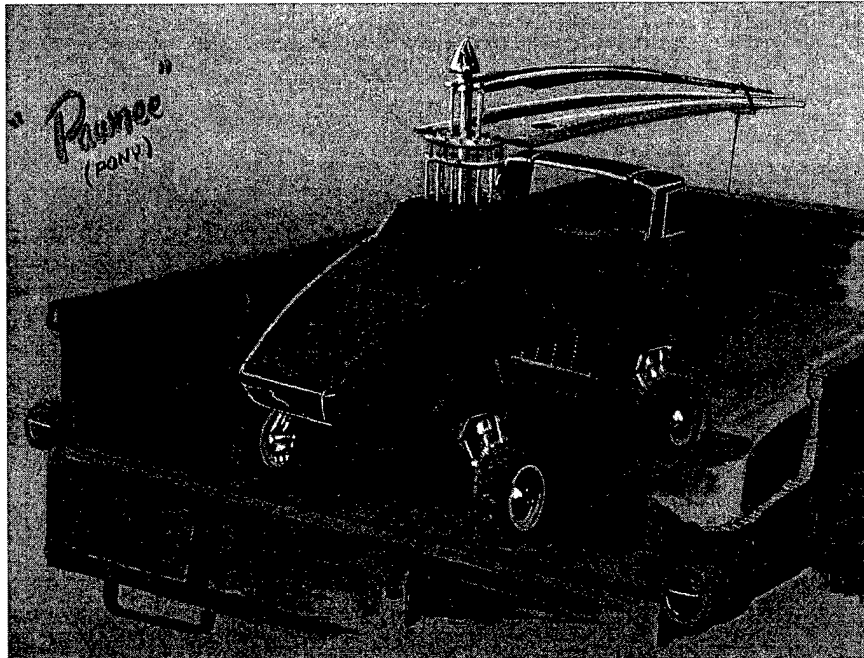

Figure 1. Baseline "Rolling Feather"

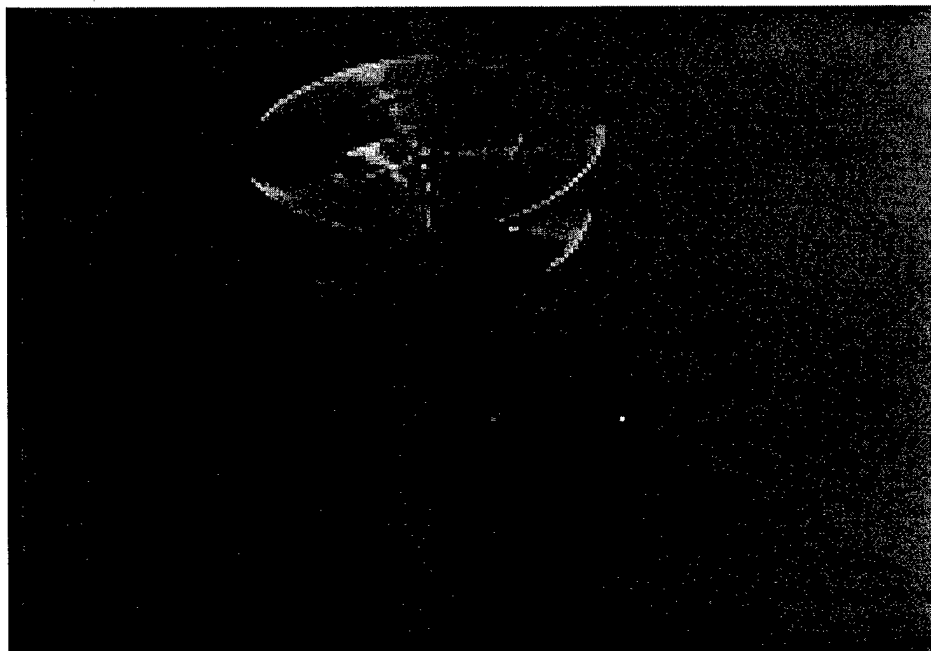

Figure 2. Concept 3B "The Weasel"

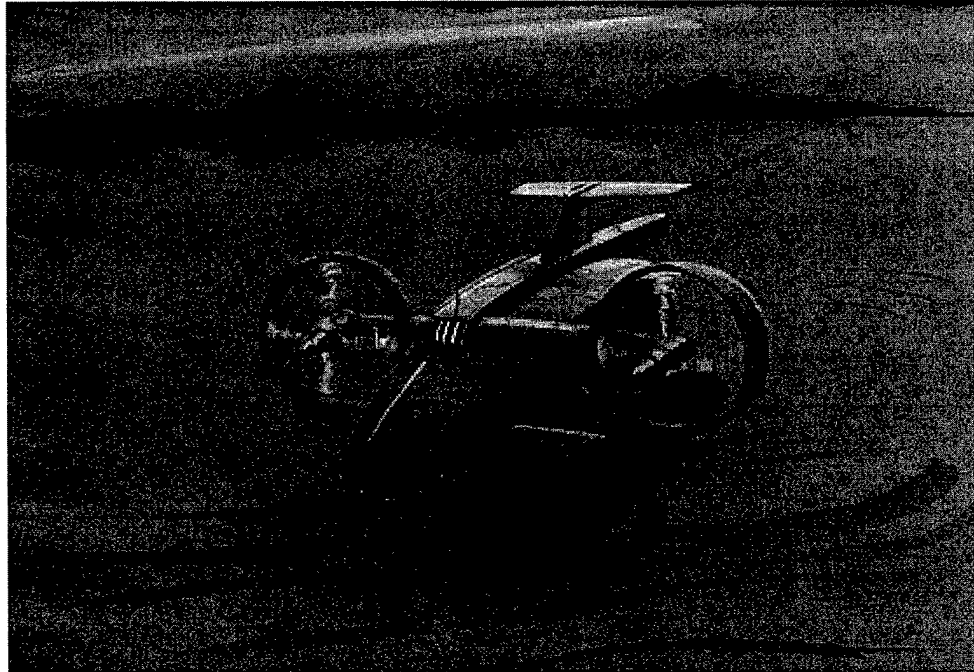

Figure 3. Concept 3C "The Womprat"

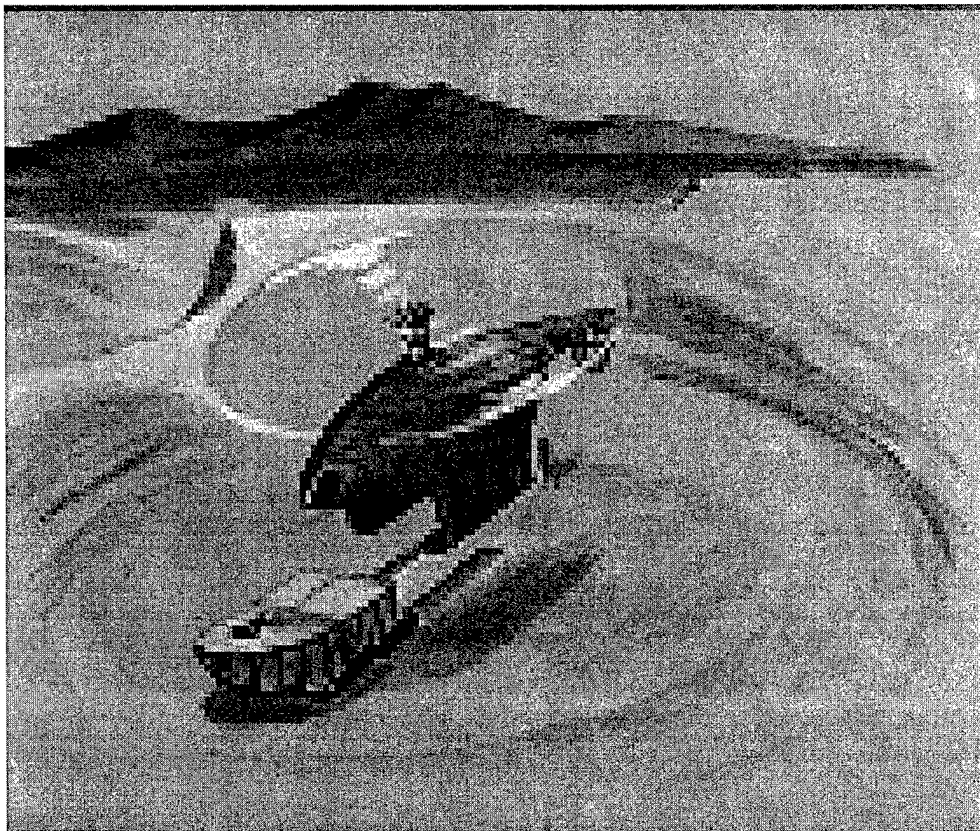

Figure 4. Concept 3D "The Chicken Hawk"

Table 1. Concept Evaluation Matrix

The purpose of the concept evaluation matrix is to objectively select the best concept. A “+” meets the requirements better than the baseline, and “=” indicates that the requirements is the same as the baseline, and a “-” indicates that the requirements are not met as well as the baseline. The total is the factor times the evaluation with a “+” getting 1 point, a “=” getting 0 points, and a “-” getting -1 points.

Required Attributes	Factor	Baseline	The Weasel	The Womprat	The Chicken Hawk
Airspeed, 30 km/hr	1		--	+	+
Vertical Climb, 1000 fpm	2		-	-	-
Ground Speed, 6 km/hr	1				+
Flight Profile, Hover-Full	1				
Operational Altitude, 0-250 ft AGL	1				
Endurance, 4 hours	1				
Payload, 60 lbs	2				+
Range, 15 km	1		+	--	+
Operation, Semi-Autonomous	2		+	+	+
Transportable, HMMWV, UH-60	1			+	-
Max Weight, 1500 lbs	1		+	+	+
Maintenance	1.5			+	
Rotor Span (for NOE flight)	1			+	
Cost	1		+	-	+
System complexity	1			--	--
Totals			2	2.5	5

Table 2. Concepts Comparison

Common Engineering Criteria	Baseline	IPT 1	IPT 1	IPT 3
	Rolling Feather	Weasel	Womprat	Chicken Hawk
Air Configuration	Coaxial Rotor	Coaxial Rotor	Ducted Fans	Single Rotor with tail
Ground Configuration	Wheels-rubber Golf Cart type	Wheels-rubber Golf Cart type	Wheels-rubber Golf Cart type	Skids and wheels
Payload Mass, kg (lb)	27.2 kg (60 lb)	27.2 kg (60 lb)	27.2 kg (60 lb)	27.2 kg (60 lb)
Assumed Gross Takeoff Weight, kg (lb)	503 kg (1109lb)	544 kg (1200 lbs)	544 kg (1200 lbs)	544 kg (1200 lbs)
Aero Propulsion Type	Piston Engine	Turbine Engine	Turbine Engine	Diesel Engine
Disk Loading N/m ² (lbf/ft ²)	6.14	6.396	96.925	5.424
Energy Source for Air Transport	AvGas 100 LL	Diesel, Jet Fuel	JP-4, JP-5	Diesel
Ground Propulsion Type	Electric Motors	Electric Motors	None (aero fans drive)	Electric Motors
Energy Source for Ground Transport	Electric (Battery)	Electric Generator	N/A	Electric (Battery)
Power to HOGE at 4k ft. - 95° F, kW (hp)	64.9 kW (87 hp)	74.6 kW (100 hp)	208.8 kW (280 hp)	63.4 kW (85 hp)
Cruise Power, kW (hp)	39.5 kW (53 hp)	49.2 kW (66 hp)	217 kW (291 hp)	31.3 kW (42 hp)
Basis of Autonomous control	none	Internal CPU	Internal CPU	Internal CPU
Primary BLOS Method	Ground radio	Satellite radio	Satellite radio	Satellite radio
Primary Navigation Method	GPS	GPS	GPS	GPS
Primary Sensor Type	FLIR Camera	FLIR Camera	FLIR Camera	FLIR Camera
Enabling Technology	Existing	Existing	Existing	Existing
Team-Selected Engineering Criteria				
Team Selected Category 1				
Team Selected Category 2				
Team-Selected Category 3				

References

Grover, A.J., "A Simulation Model for Predicting Unscheduled Maintenance Actions for an Unmanned Aerial Vehicle System." The University of Alabama in Huntsville, 1998

<http://www.aeroworldnet.com/1ra01137.htm>. Accessed: February 21, 2002

<http://www.helosim.com/coaxialarticle.htm>. Accessed: February 21, 2002

Anderson, J.D., 2001 "Fundamentals of Aerodynamics." McGraw-Hill

Anderson, J.D., 1999 "Introduction to Flight." McGraw-Hill

Leishman, J.G., 1999. "Principles of Helicopter Aerodynamics." Cambridge Press

Berry, John. 2002. Presentation at AHS Rotorcraft Conceptual Design Symposium. Huntsville, AL. 17 January

Williams, Lew. 2002. Presentation at AHS Rotorcraft Conceptual Design Symposium. Huntsville, AL. 17 January

McKay, Joe. 2002. Presentation at AHS Rotorcraft Conceptual Design Symposium. Huntsville, AL. 17 January

Bibliography

Grover, A.J., "A Simulation Model for Predicting Unscheduled Maintenance Actions for an Unmanned Aerial Vehicle System." The University of Alabama in Huntsville, 1998

<http://www.aeroworldnet.com/1ra01137.htm>. Accessed: February 21, 2002

<http://www.helosim.com/coaxialarticle.htm>. Accessed: February 21, 2002

Benfield, P.J. 2002. Interview by author. Huntsville, AL. February 22

Coutrot, A. 2002. Interview by author. Paris, France. January 28

Grivel, T. 2002. Interview by author. Paris, France. February 7

Combes, E. 2002. Interview by author. Paris, France. February 8

www.turbomeca-support.com Accessed: February 3, 2002

<http://quasiturbine.promci.qc.ca> Accessed February 3 & 15, 2002

http://www.toyota.fr/g/g01_02_02.html Accessed February 20, 2002

<http://daimlerchrysler.be/fr/fr-dcd111.htm> Accessed February 13, 2002

www.biosfero.fr/biosfero.dir/hybrid.dir Accessed February 13, 2002

www.mercedes.be/fr/news/1999/fr_9903.html Accessed February 13, 2002

Anderson, J.D., 2001 "Fundamentals of Aerodynamics." McGraw-Hill

Anderson, J.D., 1999 "Introduction to Flight." McGraw-Hill

Leishman, J.G., 1999. "Principles of Helicopter Aerodynamics." Cambridge Press

Berry, John. 2002. Presentation at AHS Rotorcraft Conceptual Design Symposium. Huntsville, AL. 17 January

Williams, Lew. 2002. Presentation at AHS Rotorcraft Conceptual Design Symposium. Huntsville, AL. 17 January

McKay, Joe. 2002. Presentation at AHS Rotorcraft Conceptual Design Symposium. Huntsville, AL. 17 January

Word List

AGL	Above Ground Level
AI	Artificial Intelligence
ATR	Automatic Target Recognition
BDA	Battlefield Damage Assessment
BLOS	Beyond Line of Sight
C2	Command and Control
DoD	Department of Defense
FCC	Federal Communications Commission
fpm	feet per minute
ft	feet
GPS	Global Positioning System
HMMWV	High-Mobility, Multipurpose Wheeled Vehicle
IFF	Identify Friend or Foe
INS	Inertial Navigation System
IPT	Integrated Product Team
km	kilometers
km/hr	kilometers per hour
lbs	pounds
LOS	Line Of Sight
RISTA	Reconnaissance, Intelligence, Surveillance, Target Acquisition
RMS	Root Mean Square
TA	Terrain Avoidance
TF	Terrain Following
UAH	The University of Alabama in Huntsville
UH-60	Utility Helicopter
VROC	Vertical Rate Of Climb

Appendix C - Sample Calculations

C1 – Aerodynamics

Concept 3

1 rotor and tail separate grnd. vehicle

$$r := 8 \text{ ft}$$

$$W := 1262.5 \text{ lbf}$$

$$R_C := 500 \frac{\text{ft}}{\text{min}}$$

$$r = 2.438 \text{ m}$$

$$W = 5.616 \cdot 10^3 \text{ N}$$

$$\rho := 1.078 \frac{\text{kg}}{\text{m}^3}$$

$$R_C = 2.54 \frac{\text{m}}{\text{s}}$$

$$W_h := W$$

$$A := \pi \cdot r^2$$

$$P_i := \sqrt{\frac{W_h^3}{2 \cdot \rho \cdot A}}$$

$$P_i = 6.632 \cdot 10^4 \text{ W}$$

$$FM := .85$$

Figure of Merit

$$P_i = 88.932 \text{ hp}$$

$$P_{iFM} := \frac{P_i}{FM \cdot .9}$$

$$P_{iFM} = 116.25 \text{ hp}$$

Hover Power

$$\text{Excess} := R_C \cdot W_h$$

$$\text{Excess} = 1.426 \cdot 10^4 \text{ W}$$

$$\text{Excess} = 19.129 \text{ hp}$$

Power to Climb

$$P_{\text{total}} := P_{iFM} + \frac{\text{Excess}}{.9}$$

$$P_{\text{total}} = 1.025 \cdot 10^5 \text{ W}$$

$$P_{\text{total}} = 137.505 \text{ hp}$$

Power to Climb

Solidity

$$\text{Blades} := 2$$

$$AR := 12$$

$$\sigma := \frac{\text{Blades}}{\pi \cdot AR}$$

$$\sigma = 0.053$$

$$\text{Loading} := \frac{W}{A}$$

$$\text{Loading} = 6.279 \frac{\text{lbf}}{\text{ft}^2}$$

$$C_L := 1.2$$

$$C_T := \frac{C_L \cdot \sigma}{6}$$

$$C_T = 0.011$$

$$V_{\text{tip}} := \sqrt{\frac{W_h}{\rho \cdot A \cdot C_T}}$$

$$V_{\text{tip}} = 162.127 \frac{\text{m}}{\text{s}}$$

$$\Omega := \frac{V_{\text{tip}}}{r}$$

$$\Omega = 66.489 \frac{\text{rad}}{\text{s}}$$

$$\Omega_{\text{rpm}} := \Omega \cdot \frac{60}{2 \cdot \pi}$$

$$\Omega_{\text{rpm}} = 634.924 \text{Hz}$$

RPMdisregard Hz

Assuming 30 km/h, the craft will require the following horsepower

$$V_{\text{air}} := 30 \frac{\text{km}}{\text{hr}}$$

$$V_{\text{air}} = 8.333 \frac{\text{m}}{\text{s}}$$

Assume the vehicle has a Cd of 1.5 and a frontal area of 1 m²

$$C_d := 1.5$$

$$A_{\text{frontal}} := 1 \text{ m}^2$$

$$D := .5 \cdot \rho \cdot V_{\text{air}}^2 \cdot C_d \cdot A_{\text{frontal}}$$

$$D = 56.146 \text{N}$$

$$D = 12.622 \text{lbf}$$

Thrust Required for 30 km/h

$$T_{30} := \sqrt{D^2 + W_h^2}$$

$$T_{30} = 5.616 \cdot 10^3 \text{ N}$$

$$T_{30} = 1.263 \cdot 10^3 \text{ lbf}$$

Maximum Velocity

$$T_{\text{fullPwr}} := \sqrt[3]{2 \cdot \rho \cdot A \cdot [(P_{\text{total}} \cdot 0.9)^2]}$$

$$T_{\text{fullPwr}} = 7 \cdot 10^3 \text{ N}$$

Thrust at 90% power

$$T_{\text{fullPwr}} = 1.574 \cdot 10^3 \cdot \text{lbf}$$

$$D_{\text{fullPwr}} := \sqrt{T_{\text{fullPwr}}^2 - W_h^2}$$

$$D_{\text{fullPwr}} = 4.178 \cdot 10^3 \text{ N}$$

$$D_{\text{fullPwr}} = 939.35 \cdot \text{lbf}$$

$$V_{\text{fullPwr}} := \sqrt{\frac{D_{\text{fullPwr}}}{.5 \cdot \rho \cdot A_{\text{frontal}} \cdot C_d}}$$

Angle to Horizon

$$V_{\text{fullPwr}} = 71.89 \frac{\text{m}}{\text{s}}$$

$$\text{AoA} := -\text{acos}\left(\frac{W_h}{T_{\text{fullPwr}}}\right)$$

$$V_{\text{fullPwr}} = 258.803 \frac{\text{km}}{\text{hr}}$$

$$\text{AoA} = -36.651 \cdot \text{deg}$$

$$V_{\text{fullPwr}} = 160.813 \cdot \text{mph}$$

Tail rotor Calculation

$$r := 2 \text{ ft}$$

$$W := 106.6886 \cdot \text{lbf}$$

$$r = 0.61 \text{ m}$$

$$W = 474.575 \text{ N}$$

$$\rho := 1.078 \frac{\text{kg}}{\text{m}^3}$$

$$W_h := W$$

$$A := \pi \cdot r^2$$

$$P_i := \sqrt{\frac{W_h^3}{2 \cdot \rho \cdot A}}$$

$$P_i = 6.516 \cdot 10^3 \text{ W}$$

$$\text{FM} := .85$$

Figure of Merit

$$P_i = 8.739 \cdot \text{hp}$$

$$P_{i\text{FM}} := \frac{P_i}{\text{FM} \cdot 9}$$

$$P_{i\text{FM}} = 11.423 \cdot \text{hp}$$

Hover Power

Solidity

Blades := 2

AR := 12

$$\sigma := \frac{\text{Blades}}{\pi \cdot \text{AR}}$$

$\sigma = 0.053$

$$\text{Loading} := \frac{W}{A}$$

$$\text{Loading} = 8.49 \frac{\text{lbf}}{\text{ft}^2}$$

$C_L := 1.2$

$$C_T := \frac{C_L \cdot \sigma}{6}$$

$C_T = 0.011$

$$V_{\text{tip}} := \sqrt{\frac{W_h}{\rho \cdot A \cdot C_T}}$$

$$V_{\text{tip}} = 188.52 \frac{\text{m}}{\text{s}}$$

$$\Omega := \frac{V_{\text{tip}}}{r}$$

$$\Omega = 309.253 \frac{\text{rad}}{\text{s}}$$

$$\Omega_{\text{rpm}} := \Omega \cdot \frac{60}{2 \cdot \pi}$$

$$\Omega_{\text{rpm}} = 2.953 \cdot 10^3 \text{ Hz}$$

RPMdisregard Hz

C2 - Aerodynamics

Velocity.Kt	Mu	Cpi	Pi	Cp0	P0	Cpp	Pp	Cp	HP
0	0.00	0.001161	96	0.000041	3	0.000000	0	0.001202	116
1	0.00	0.001161	96	0.000041	3	0.000000	0	0.001202	117
5	0.02	0.001150	95	0.000041	3	0.000000	0	0.001192	116
10	0.03	0.001118	92	0.000042	3	0.000002	0	0.001161	113
20	0.07	0.000999	82	0.000042	3	0.000014	1	0.001055	103
30	0.10	0.000842	70	0.000043	4	0.000048	4	0.000933	91
40	0.13	0.000694	57	0.000045	4	0.000114	9	0.000852	83
50	0.16	0.000576	48	0.000047	4	0.000222	18	0.000845	82
60	0.20	0.000487	40	0.000049	4	0.000384	32	0.000920	89
70	0.23	0.000421	35	0.000051	4	0.000610	50	0.001082	105
80	0.26	0.000369	31	0.000055	5	0.000910	75	0.001334	130
90	0.30	0.000329	27	0.000058	5	0.001296	107	0.001683	164

Co-Axial

Velocity.Kt	Mu	Cpi	Pi	Cp0	P0	Cpp	Pp	Cp	HP
5	0.02	0.001150	95	0.000041	3	0.000000	0	0.001192	98
15	0.05	0.001066	88	0.000042	3	0.000006	0	0.001114	92
25	0.08	0.000922	76	0.000043	4	0.000028	2	0.000993	82
40	0.13	0.000694	57	0.000045	4	0.000114	9	0.000852	70
75	0.25	0.000394	33	0.000053	4	0.000750	62	0.001197	99
100	0.33	0.000296	24	0.000062	5	0.001778	147	0.002137	176
125	0.41	0.000237	20	0.000074	6	0.003473	287	0.003784	313
150	0.49	0.000198	16	0.000088	7	0.006001	496	0.006287	519
175	0.58	0.000170	14	0.000105	9	0.009530	787	0.009804	810
200	0.66	0.000149	12	0.000124	10	0.014225	1175	0.014497	1197
225	0.74	0.000132	11	0.000146	12	0.020254	1673	0.020532	1696

C3 – Propulsion

Here are the calculations we made for the gearwheels dimension.

We designed the teeth for it to withstand the strength and the torque due to the rotation:

Here is the formulation we use to calculate the teeth wheel strength calculation.

$$d = z * m$$

$$pas = \pi * m$$

$$c = P / N * 30 / \pi$$

$$r_m = d / 2 * b / 2 * \sin(\delta)$$

$$F_t = c / r_m$$

$$\sigma = F_t / (b * m * Y)$$

$$K_v = 6 / (6 + V)$$

$$\sigma_e = \sigma / K_v$$

Here is the meaning of the letter used in the formulas:

σ : strength

σ_e is the strength with a safety coefficient .(due to the speed)

z: number of teeth

d: diameter

m: module

b :width of the wheel.

c :torque.

ft : force

rm: radius

K_v : safety coefficient

V : shaft speed

P : power

pas : pitch

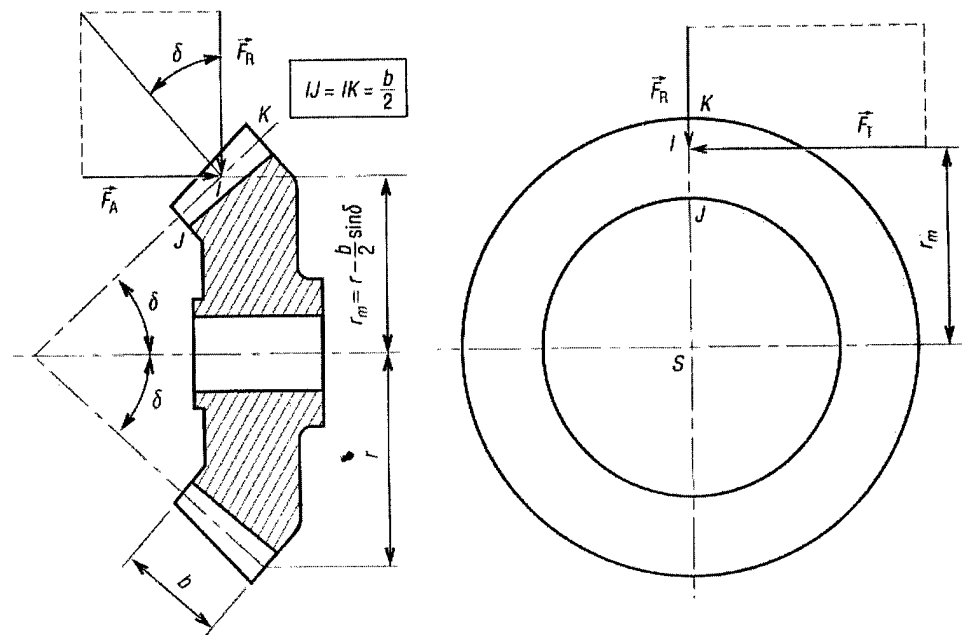

Figure 24 Cross sectional of bevel

These calculations led to the designed of the following five gearwheels:

Table 16 Design of five gearwheels

	<i>epicycle (1)</i>	<i>epicycle(2)</i>	<i>epicycle (3)</i>	<i>bevel(1)</i>	<i>bevel (2)</i>
<i>P (hp)</i>	130	130	130	130	130
<i>N (rpm)</i>	1707	2414	2800	24148	611
<i>α (degrees)</i>	20	20	20	20	20
<i>b(in)</i>	1.38	1.38	1.38	1.38	1.38
<i>z</i>	41	29	25	18	71
<i>m (in)</i>	0.18	0.18	0.18	0.18	0.18
<i>d (in)</i>	7.24	5.12	4.41	3.19	12.56
<i>δ (degrees)</i>				45	45
<i>pas (in)</i>	0.56	0.56	0.56	0.56	0.56
<i>c (lb ft)</i>	399.8	282.73	243.74	282.73	1115.25
<i>rm (in)</i>				1.1	5.8
<i>Ft (lbs)</i>	1325.7	1326.94	1327.76	3080.33	2314.4
<i>(See the table for each Y)</i>					
<i>Y</i>	0.35	0.36	0.34	0.305	0.43
<i>σ (lbf/ft²)</i>	223.41	217.4	230.35	595.74	317.5
<i>V(ft/s)</i>	53.9	53.9	53.9	33.53	33.53
<i>Kv</i>	0.27	0.27	0.27	0.37	0.37
<i>σe(psi)</i>	58042.7	56444.3	59774.4	111959	59606.2

σ is the strength calculate with the force and the Y is found in Table 12.

In Figure 24, there are two lines for two α values. We use the line with $\alpha=20$ because it is the most common value in the industry, and the cheaper to manufacture.

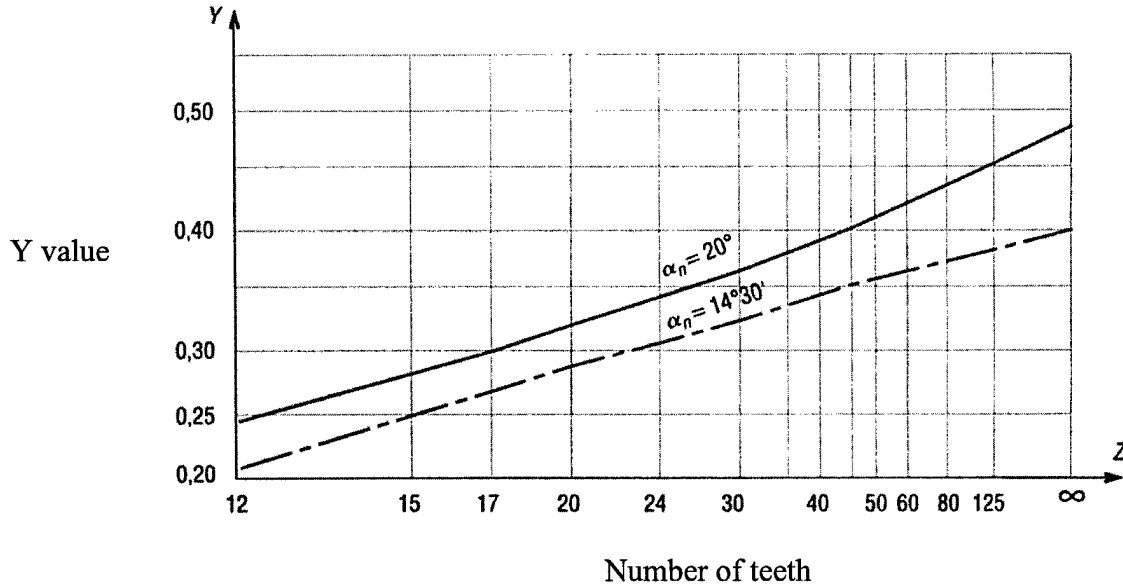

Figure 25 Determination of the Y value as a function of the number of teeth

The gearwheel calculation is a compromise between the teeth strength and the system weight regarding the material.

C4a - Ground Robotics- Ground vehicle electric motor

Imperial Electric 56 frames Permanent Magnet Motor

Rugged, Dependable, Long life Motors

115 and 230VAC Rectified, 36 and 24VDC

0.75 to 6.0 HP - .6 to 4.5 KW

1000 to 4000 rpm Shaft Output

Full-Keyed Shaft

Face Mount in Any Direction

Operates in Both Directions

All Ball Bearing Construction

Brush Life at 3,000 hrs Min.

Ambient Temp 40 degrees C

Insulation Class F

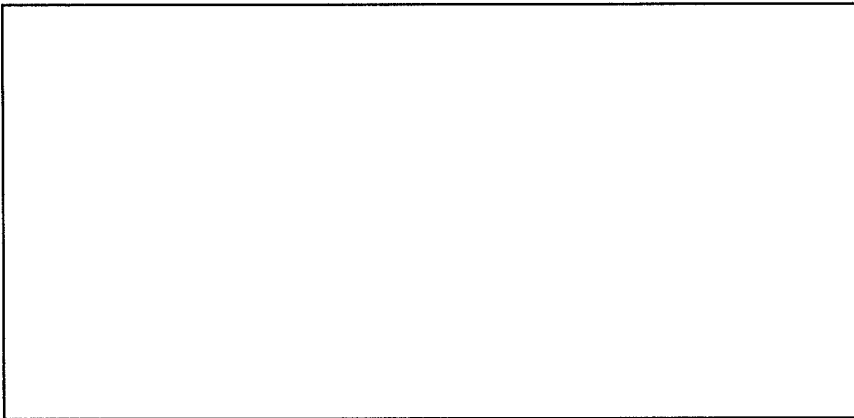
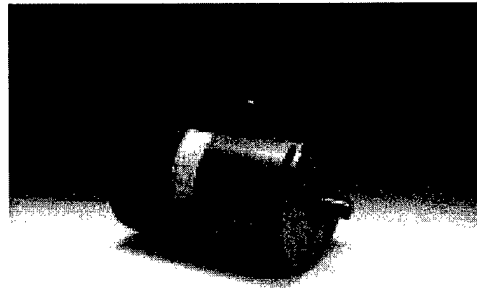

**C4b - Ground Robotics- Ground vehicle battery system
Saft Batteries**

- Maintenance-free operation
- High power / energy ratio
- Excellent safety and perfect resistance to abuse testing
- Easy fast charging
- Fully recyclable
- Liquid cooling
- More than 1,200 charge / discharge cycles
- Monoblock design
- Nickel foam positive electrode

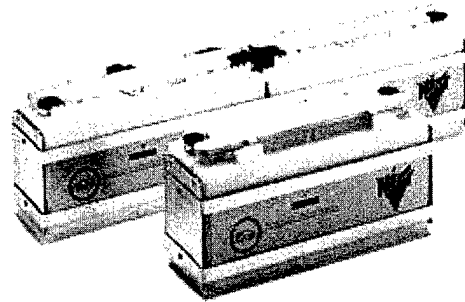

Electrical characteristics	
Nominal voltage (V)	24
Rated capacity at C/3 rate (Ah)	109
Typical specific energy (Wh/kg at C/3)	73
Typical energy density (Wh/dm ³ at C/3)	164
Typical specific power (W/kg at 80% DOD,30 sec, 2/3 U _o)	170
Typical power density (W/dm ³)	373
Mechanical characteristics	
Maxi dimensions (mm) : L x W x H	767x120x195
Typical weight (kg & lbs)*	38.7 or 85.14
Typical volume (dm ³)	17.4
Operating conditions	
Operating temperature range (°C)	20 /+ 60
Transport or storage temperature range (°C)	- 40 /+ 65
liquid cooling included	

Very High Specific Energy
 Maintenance free
 High cycle life (>1500 cycles at 80 % DOD,
 cycles DST)
 Plastified carbon anode
 Nickel oxyde based cathode
 Organic electrolyte

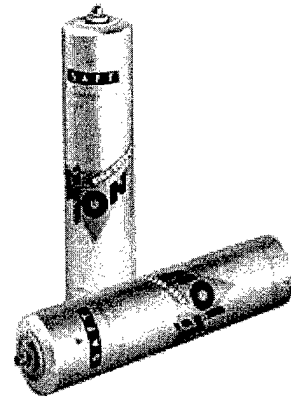

Electrical characteristics	
Nominal voltage (V)	3.6
Capacity at C/3 rate (Ah)	41
Specific energy (Wh/kg)	140
Energy density (Wh/dm ³)	290
Specific power (W/kg)	420
Power density (W/dm ³)	880

Mechanical characteristics	
Diameter (mm)	54
Height max (mm)	220
Weight (kg & lbs)	1.05 or 2.31
Volume (dm ³)	0.5

Operating conditions	
Operating temperature range (°C)	- 10 /+ 45
Transport or storage temperature range (°C)	- 40 /+ 65

C5 - Avionics

Air

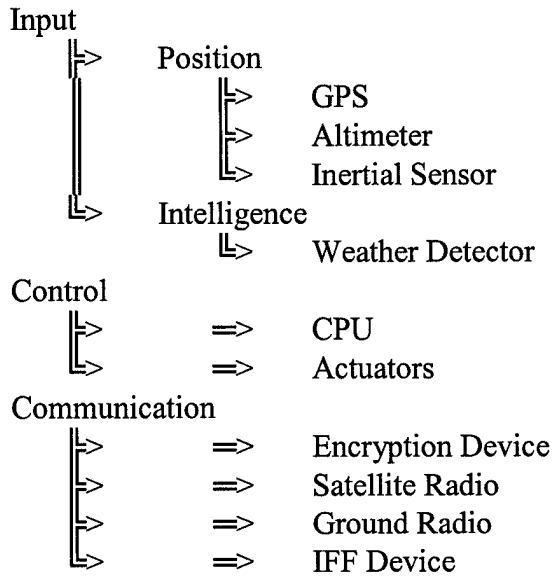

Ground

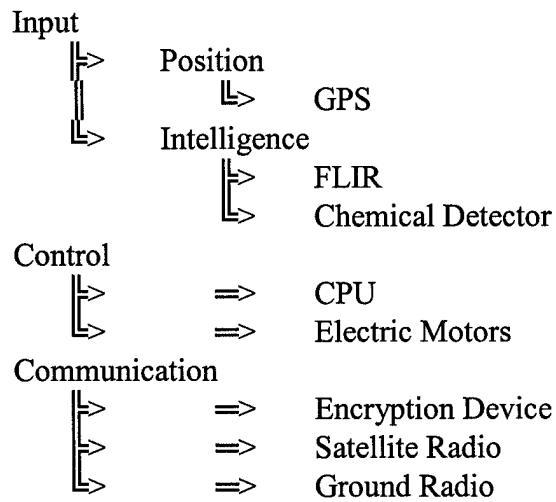

Ground Station

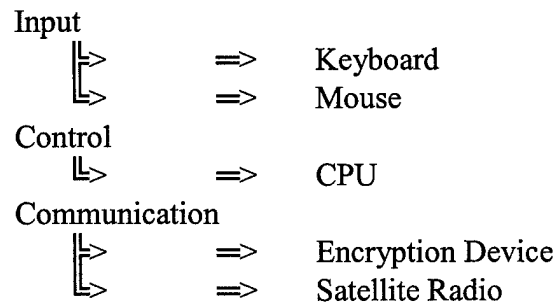

C6 - Mechanical Configurations

Aerial Unit			
Item	Weight (lb)	Info	
1	Chassis	42.16	Styrene Acrylonitrile, 35% Glass Reinforced / Aluminum 6069-T6
2	Engine	185	[Power System]
3	Batteries	8.8	[Power System]
4	20Gal Fuel Tank	4.83	High Density Polyethylene
5	Transmission	--	[Drive System]
5a	Gear Box	85	Gear Box
5b	Main Rotor	68	Main Rotor Assembly
5c	Drive Shaft	25	AISI Grade 18Ni Steel
5d	Actuators	8	[Avionic System]
6	Weather D	5	[Avionic System]
7	Avionics	--	[Avionic System]
7a	IFF	5	[Avionic System]
7b	GPS	1	[Avionic System]
7c	Radar Altimeter	3	[Avionic System]
8	CPU	8	[Avionic System]
9	Radio	6.8	[Avionic System]
10	Sat Com	10.2	[Avionic System]
11	Encrypting	3	[Avionic System]
Total Weight		468.79	lb

Ground Unit			
Item	Weight (lb)	Info	
1	Chassis	10.02	Styrene Acrylonitrile, 35% Glass Reinforced
2	Batteries	--	[Power System]
2a	Drive Bat	129.36	[Power System]
2b	Elec Bat	16.17	[Power System]
3	Motors (x2)	39.68	[Drive System]
4	Drive	44.09	[Drive System]
5	Radio	6.8	[Electronic System]
6	Chem Detector	10	[Electronic System]
7	GPS	1	[Electronic System]
8	Optics	25	[Electronic System]
9	CPU	4	[Electronic System]
10	Sat Com	10.2	[Electronic System]
11	Encrypting	3	[Electronic System]
Total Weight		299.32	lb

Avionics	58.8	lb	Vehicle Weight	768.11	lb
Electronics	76.17	lb	40%	307.244	lb
Electrical Total	134.97	lb	140% Vehicle Weight	1075.354	lb
			7.38 Gal Fuel	53.78	lb
Chassis Total	52.18	lb	Cargo	120	lb
Aerial Drive Total	367.83	lb	Final Weight	1249.134	lb
Ground Drive Total	213.13	lb			

Final Weight	1249.134	lb
--------------	----------	----

C7 - Programmatic

Air Unit = 656.3 lbs

\$1181340/unit

300 units=\$354402000

	% of total cost for FY02 (\$)	total program cost for FY02 (\$)
RDT&E	10	35,440,200
Production	25	88,600,500
O&S	65	230,361,300
Disposal	n/a	n/a
Total	100	354,402,000

Ground Unit = 419.05 lbs

\$754290/unit

300 unit=\$226287000

	% of total cost for FY02 (\$)	total program cost for FY02 (\$)
RDT&E	10	22,628,700
Production	25	56,571,750
O&S	65	147,086,550
Disposal	n/a	n/a
Total	100	226,287,000

Appendix D – Web Pages

Copies of web pages referenced in this volume are located on the “Unmanned Hybrid Vehicle” CD that was provided as a supplement to the deliverables.