

**UNITED STATES AIR FORCE  
IERA**

---

**B-1 Confined Space  
Technical Guidance Document**

**Sophia Kapranos**

**Pacific Environmental Services, Inc.  
560 Herndon Parkway, Suite 200  
Herndon, VA 20170-5240**

**Joseph Costantino, Captain, USAF, BSC  
Tammy J. Hintz, Staff Sergeant, USAF**

**20021129 064**

**August 2002**

*Approved for public release;  
distribution is unlimited.*

**Air Force Institute for Environment, Safety  
and Occupational Health Risk Analysis  
Risk Analysis Directorate  
Health and Safety Division  
2513 Kennedy Circle  
Brooks Air Force Base TX 78235-5116**

## NOTICES

When Government drawings, specifications, or other data are used for any purpose other than in connection with a definitely Government-related procurement, the United States Government incurs no responsibility or any obligation whatsoever. The fact that the Government may have formulated or in any way supplied the said drawings, specifications, or other data, is not to be regarded by implication, or otherwise in any manner construed, as licensing the holder or any other person or corporation; or as conveying any rights or permission to manufacture, use, or sell any patented invention that may in any way be related thereto.

The mention of trade names or commercial products in this publication is for illustration purposes and does not constitute endorsement or recommendation for use by the United States Air Force.

The Office of Public Affairs has reviewed this report, and it is releasable to the National Technical Information Service, where it will be available to the general public, including foreign nationals.

This report has been reviewed and is approved for publication.

Government agencies and their contractors registered with Defense Technical Information Center (DTIC) should direct requests for copies to: Defense Technical Information Center, 8725 John J. Kingman Rd., STE 0944, Ft. Belvoir, VA 22060-6218.

Non-Government agencies may purchase copies of this report from: National Technical Information Services (NTIS), 5285 Port Royal Road, Springfield, VA 22161-2103.

  
ROBERT B. SHUMATE, LtC, USAF, BSC  
Chief, Health and Safety Division

  
MOHAMMAD A. HOSSAIN, Col, USAF, BSC  
Director, Risk Analysis Directorate

REPORT DOCUMENTATION PAGE			Form Approved OMB No. 0704-0188	
Public reporting burden for this collection of information is estimated to average 1 hour per response, including the time for reviewing instructions, searching existing data sources, gathering and maintaining the data needed, and completing and reviewing the collection of information. Send comments regarding this burden estimate or any other aspect of this collection of information, including suggestions for reducing this burden, to Washington Headquarters Services, Directorate for Information Operations and Reports, 1215 Jefferson Davis Highway, Suite 1204, Arlington, VA 22202-4302, and to the Office of Management and Budget, Paperwork Reduction Project (0704-0188), Washington, DC 20503.				
1. AGENCY USE ONLY (Leave blank)	2. REPORT DATE August 2002	3. REPORT TYPE AND DATES COVERED Final		
4. TITLE AND SUBTITLE B-1 Confined Space Technical Guidance Document			5. FUNDING NUMBERS	
6. AUTHOR(S) Joseph Costantino, Captain, USAF, BSC Tammy Hintz, Staff Sergeant, USAF *Sophia Kapranos, Industrial Hygienist				
7. PERFORMING ORGANIZATION NAME(S) AND ADDRESS(ES) *Pacific Environmental Services, Inc. 560 Herndon Parkway, Suite 200 Herndon, VA 20170-5240			8. PERFORMING ORGANIZATION REPORT NUMBER	
9. SPONSORING/MONITORING AGENCY NAME(S) AND ADDRESS(ES) Air Force Institute for Environment, Safety and Occupational Health Risk Analysis Risk Analysis Directorate Health and Safety Division 2513 Kennedy Circle Brooks AFB TX 78235-5116			10. SPONSORING/MONITORING AGENCY REPORT NUMBER  IERA-RS-BR-TR-2002-0007	
11. SUPPLEMENTARY NOTES				
12a. DISTRIBUTION AVAILABILITY STATEMENT Approved for public release; distribution is unlimited.			12b. DISTRIBUTION CODE	
13. ABSTRACT (Maximum 200 words) The following information and instructions apply to permit-required and nonpermit-required confined spaces associated with the B-1 aircraft. The majority of activities conducted within these spaces are for inspections and routine scheduled maintenance only. Flightline, depot, and other related activities are not referenced in this document. The information presented for each space type is based on the dimensions, inner characteristics, and interviews with shop personnel. Personnel performing aircraft maintenance and support are extensively trained in safe work practices, and work is conducted in accordance with (IAW) strict Technical Order (TO) and Operating Instruction (OI) directives. The TOs and OIs govern procedures such as lockout/tagout and system checks prior to entering the various areas of an aircraft.				
14. SUBJECT TERMS B-1, aircraft confined space, permit-required confined space			15. NUMBER OF PAGES 36	
			16. PRICE CODE	
17. SECURITY CLASSIFICATION OF REPORT Unclassified	18. SECURITY CLASSIFICATION OF THIS PAGE Unclassified	19. SECURITY CLASSIFICATION OF ABSTRACT Unclassified	20. LIMITATION OF ABSTRACT UL	

THIS PAGE INTENTIONALLY LEFT BLANK

## TABLE OF CONTENTS

LIST OF FIGURES.....	iv
LIST OF TABLES.....	v
INTRODUCTION.....	1
CLASSIFICATION CRITERIA.....	2
RECOMMENDED ATMOSPHERIC MONITORING.....	3
FUEL TANKS-GENERAL.....	4
INTEGRAL FUEL TANKS FORWARD FUSELAGE.....	8
INTEGRAL FUEL TANKS AFT FUSELAGE.....	10
INTEGRAL FUEL TANKS MAIN.....	12
INTEGRAL FUEL TANKS FORWARD INTERMIDATE FUSELAGE.....	14
INTEGRAL FUEL TANKS AFT INTERMIDATE FUSELAGE (#3 FORWARD).....	16
INTEGRAL FUEL TANKS AFT INTERMIDATE FUSELAGE (#3 AFT).....	18
OVER WING FAIRING (OWF) AREA.....	20
ENGINE INTAKES.....	22
AFT ELECTRONICS BAY.....	24

**LIST OF FIGURES**

Figure 1. B-1 Lancer.....1

Figure 2. Forward Fuselage Fuel Tanks.....8

Figure 3. Aft Fuselage Fuel Tanks.....10

Figure 4. Main Fuel Tank.....12

Figure 5. Forward Intermediate Fuselage Fuel Tanks.....14

Figure 6. Aft Intermediate Fuselage Fuel Tank #3 Forward.....16

Figure 7. Aft Intermediate Fuselage Fuel Tank.....18

Figure 8. Over Wing Fairing.....20

Figure 9. Engine Intakes.....22

**LIST OF TABLES**

TABLE 1. B-1 Space Classification.....2

TABLE 2. Potential Hazards (Fuel Tanks-General).....6

THIS PAGE INTENTIONALLY LEFT BLANK

# B-1 LANCER

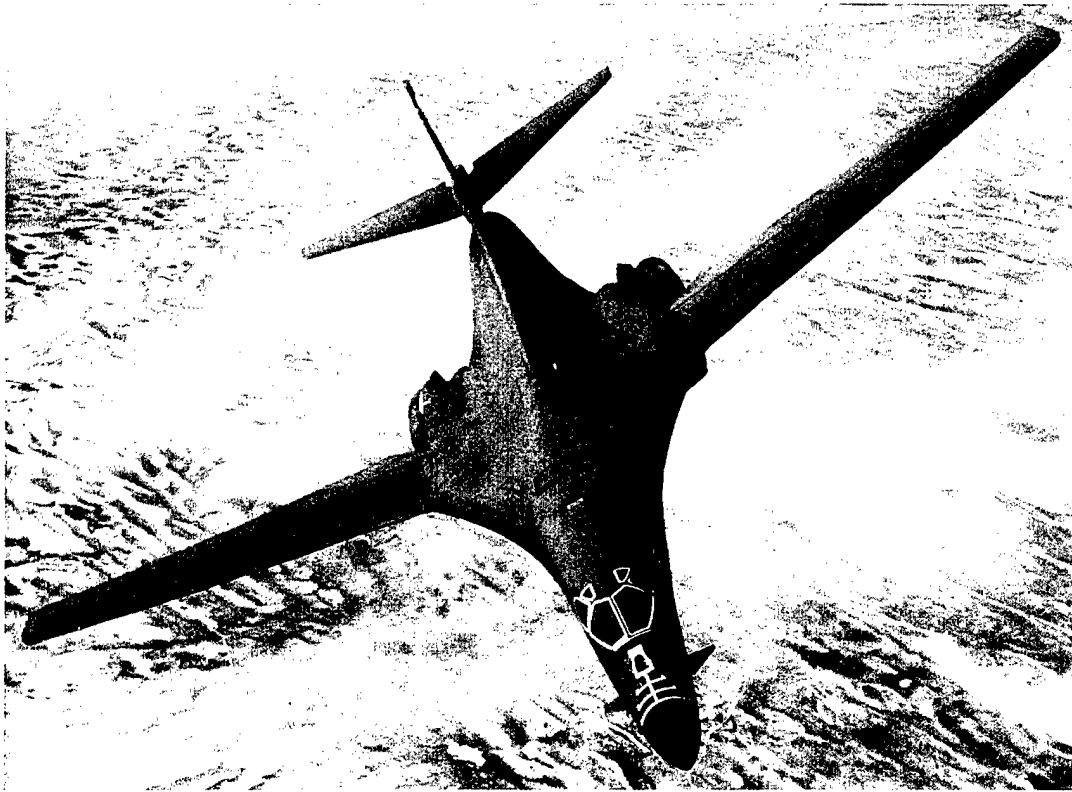

Figure 1. B-1 Lancer

## INTRODUCTION

The Confined Space Technical Guidance Document is not a standardized compliance document. For specific compliance procedures, refer to AFOSH Standard 91-25, *Confined Spaces*; OSHA Standard 29 CFR 1910.146, *Permit-Required Confined Spaces*; and all other applicable AFOSH Standards, Technical Orders (TOs), and Operating Instructions (OIs). The following information and instructions apply to permit-required and nonpermit-required confined spaces associated with the B-1 aircraft.

The majority of activities conducted within these spaces are for inspections and routine scheduled maintenance only. Flightline, depot, and other related activities are not referenced in this document. The information presented for each space type is based on the dimensions, inner characteristics, and interviews with shop personnel. Personnel performing aircraft maintenance and support are extensively trained in safe work practices, and work is conducted in accordance with (IAW) strict TO and OI directives. The TOs and OIs govern procedures such as lockout/tagout and system checks prior to entering the various areas of an aircraft. The following table, *B-1 Space Classification*, lists the classification of each space assessed on the B-1.

**TABLE 1. B-1 Space Classification**

<b>B-1 Space Classification</b>		
<b>Space Type</b>	<b>Classification</b>	<b>Page Number</b>
Integral Fuel Tanks:		4
• Forward Fuselage - #1B/#1C		8
• Aft Fuselage - #4		10
• Main - (Left/Right)	CP	12
• Forward Intermediate Fuselage - #2 (Left/Right)		14
• Aft Intermediate Fuselage - #3 (Forward)		16
• Aft Intermediate Fuselage - #3 (Aft)		18
Over-Wing Fairing (OWF)	CS	20
Engine Intake	CS	22
Aft Electronics Bay	CS	24
<b>NOTE: CS = Confined Space, CP = Permit-Required Confined Space, NC = Not a Confined Space.</b>		

**CLASSIFICATION CRITERIA**

A space is classified as a "confined space" when it meets the criteria established by AFOSH Standard 91-25, *Confined Spaces*, and OSHA Standard 29 CFR 1910.146, *Permit-Required Confined Spaces*. ALL of the following criteria must be met in order to classified a space as a confined space:

- the space is large enough to bodily enter and perform work, and
- the space has a limited means of entry and egress, and
- the space is not designed for continuous employee occupancy.

For each confined space, only one of the following criteria must be met in order to classify a confined space as permit-required:

- contains or has the potential to contain a hazardous atmosphere, or
- contains a material that has the potential for engulfing the entrant, or
- has an internal configuration such that an entrant could be trapped or asphyxiated, or
- contains any other recognized serious safety or health hazards.

## RECOMMENDED ATMOSPHERIC MONITORING

It is considered a good working practice to test the atmosphere in all confined spaces, both "permit required" and "non-permit required", prior to entry. The person designated to conduct atmospheric tests of confined spaces must be trained in operation, calibration, and maintenance of the testing equipment to include field calibration prior to each use. This may involve zero calibrating the instrument in clean air and using span gases for point calibrations. The atmospheric testing equipment must have a current calibration performed by the Test Measurement Diagnostic Equipment (TDME) lab or the manufacturer. The following atmospheric air monitoring must be conducted prior to permit-required confined space entries:

- **Oxygen (O<sub>2</sub>):** The concentration of oxygen in the confined space must be greater than or equal to 19.5 percent and less than or equal to 23.5 percent.
- **Flammability:** The concentration of flammable or combustible vapors, gas, or mist in the confined space must be less than or equal to 10 percent of the Lower Explosive Limit (LEL).
- **Toxic Materials:** Atmospheric concentration of any chemical substance must be below that level which may cause death, incapacitation, impairment of ability to self-rescue, injury, or acute illness due to its health effects.

During normal operations, entries must not be conducted when immediately dangerous to life and health (IDLH) conditions exist. Exceptions to this rule are found in AFOSH Standard 91-25, *Confined Spaces*, paragraph 4.3.

# B-1 LANCER

## FUEL TANKS – GENERAL CONDITIONS AND REQUIRED PROCEDURES

### SPACE DESCRIPTION

The B-1 aircraft contains 9 integral fuel tanks located in the fuselage area of the aircraft. Integral fuel tanks were developed because they offer the capacity of greater fuel containment with a decrease in weight over a fuel cell type construction. The integral fuel tanks are designed with seal planes instead of fuel bladders (like the fuel cells) for retaining the fuel. Seal planes provide airtight dividers between the surrounding sides of the fuel tanks. They are sealed with gaskets, structural adhesives, elastic films, or other sealants. The fuel lines/components within the fuel cells are located between the inner wall of the fuel cell and the outside of the removable bladder. The fuel tanks can contain fuel lines and various fuel components.

Confined space entries into the fuel tanks are performed IAW TO 1-1-3, *Inspection and Repair of Aircraft Integral Tanks and Fuel Cells*, 30 November 1994. The TO includes the following information regarding integral fuel tanks and fuel cells:

- Entering integral fuel tanks that have been depuddled, purged, docked, and grounded.
- Identifies specific repair/rework procedures, equipment, and chemicals that are authorized for use during entries into integral fuel tanks.
- Outlines specific safety procedures such as ventilation, personal protective equipment, emergency equipment, etc.

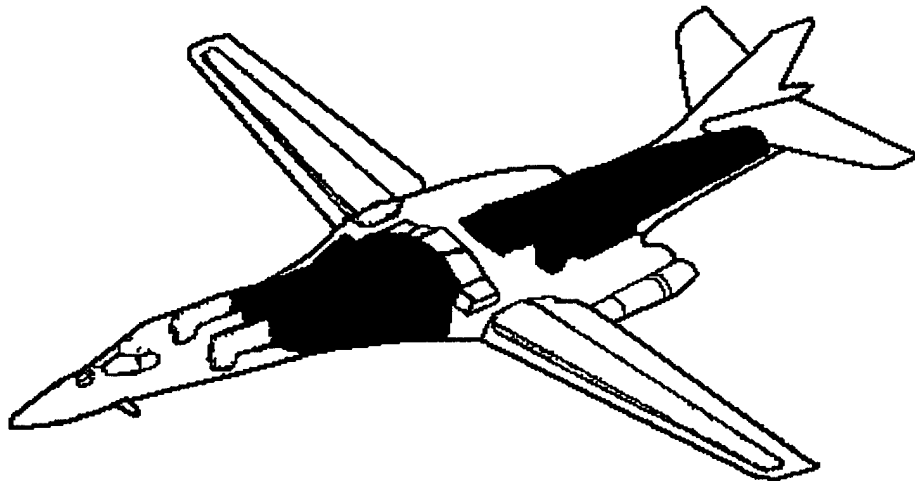

## TASKS PERFORMED WITHIN THE SPACE

Personnel from several work centers can enter the fuel tanks to perform both general and emergency maintenance activities. These work centers may include Aircraft Structural Repair, Non-Destructive Inspection Maintenance, Isochronal (ISO) Dock, etc. The majority of activities conducted within this space are for inspections and routine scheduled maintenance only, and no chemicals are used. Flightline, depot, and other related activities are not referenced in this document. However, some tasks performed during aircraft structural repair and ISO Dock maintenance, may require the use of various solvents, cleaners, adhesives, paints, and primers. The following lists scheduled routine maintenance conducted predominantly by the Fuel Systems shop:

- Performing procedures intended to remove, close, and reinstall integral tanks, fuel cells, or the rubber fuel bladder.
- Removal and reinstallation of plumbing for various fuel systems, other plumbing systems, fuel cell bladders, fuel cell foam, and other related components.
- Cleaning, testing, troubleshooting, and repairing fuel tanks, bladders, and cell cavities. This includes the application of solvents, cleaners, and adhesives.

Only authorized materials, or materials which have been fully evaluated and approved by Installation Ground Safety (SEG), Installation Fire Department (CEF), and Bioenvironmental Engineering (BE) offices can be used within the fuel tanks. Hot work, such as grinding, welding or brazing in a permit-required confined space requires a confined space entry permit AND a hot work permit. Both permits must be reviewed and approved in writing by SEG, CEF, and BE prior to conducting any hot work in the space.

## POTENTIAL HAZARDS

The following table, *Potential Hazards*, contains various hazards that could be encountered when performing permit-required confined space entries into the fuel tanks. The systems described in the table are closed/contained, and are hazardous if they are intentionally opened or a significant leak occurs. These conditions are unlikely due to personnel training and specific aircraft TOs and OIs that are strictly complied with. The TOs and OIs govern procedures such as lockout/tagout and system checks prior to entering the various areas of the aircraft.

**TABLE 2. Potential Hazards (Fuel Tanks-General)**

<b>POTENTIAL HAZARDS</b>	
<b>Hazard</b>	<b>Hazard Description</b>
<b>Combustibility</b>	The fuel tanks have the potential to contain jet fuel and/or jet fuel vapors that are combustible.
<b>Entrapment</b>	The fuel tanks are extremely confined areas that contain several structural braces and fuel components throughout the space. This creates an entrapment hazard for entry personnel due to limited maneuverability and delayed egress.
<b>Hazardous Materials Present</b>	Jet fuel and/or fuel vapors may be present. Jet fuel and its constituents (e.g., benzene, toluene, xylene) can be a potential hazard to the entrant by route of inhalation, skin absorption, ingestion, and contact.
<b>Introduction of Hazardous Materials</b>	The solvents and cleaners that are used for cleaning in the tanks, and adhesives used to seal the tanks, could potentially include hazardous materials. Only authorized chemicals should be used within the fuel tanks.
<b>Oxygen Deficiency</b>	Due to unfavorable ventilation and the possible presence of jet fuel vapors, which can displace the oxygen in these areas, oxygen deficiency is a potential hazard. In addition, several operations are performed within the fuel tanks that require the use of solvents, cleaners, and/or adhesives. Depending on the quantity and duration of use, the constituents of the chemicals could displace the oxygen within the space.
<b>Temperature Extremes</b>	Temperature extremes may present a hazard due to one or a combination of several factors such as ambient temperature, radiant heat, local winds, support equipment, and PPE.
<b>Unfavorable Natural Ventilation</b>	Due to the small entrances and confined areas, there is normally minimal natural ventilation within these spaces.

**RECOMMENDED ENGINEERING/ADMINISTRATIVE CONTROLS**

The following engineering and administrative controls should be in place prior to making permit-required confined space entries into the fuel tanks:

- **Depuddling:** Fuel tanks will be defueled, drained, depuddled, and purged to the extent necessary to perform the required tasks.
- **Electrical:** Except for specific depot exclusions, the aircraft electrical system shall be deenergized and locked and tagged out prior to opening integral fuel tanks and fuel cells. The aircraft should also be grounded and bonded prior to entry.
- **Lockout/Tagout:** Lockout/tagout procedures must be performed on electrical and mechanical systems prior to entry. Danger tags are placed on the relevant circuit breakers, batteries, and external power. Restricted areas are established to minimize foot traffic.

- **Ventilation:** Fuel tanks shall be ventilated for 30 minutes prior to space occupancy and continuously during entry. Ventilation must be used as necessary to ensure safe atmospheric conditions during entry.
- **Administrative:** Personnel should minimize the time spent in confined spaces by performing only necessary tasks within the space. Any work that can be conducted outside of the space should not be performed during the entry.

## **RECOMMENDED PERSONAL PROTECTIVE EQUIPMENT (PPE)**

PPE must be assigned based on the atmospheric conditions of the confined space, the physical hazards present, the task being performed, and the hazardous materials being used. Protective equipment that may be used for tasks in this space include:

- respiratory protection,
- non-absorbent coveralls,
- approved footwear,
- nitrile/neoprene gloves or gloves for sealant operations,
- cap or head covering,
- goggles or safety glasses with side shields, and
- neoprene rubber knee pads, elbow pads, or mats.

## **RECOMMENDED EMERGENCY EQUIPMENT**

The following emergency equipment is recommended to be present in the Fuels or Flightline Maintenance area and verified to be in working condition by the designated entry authority prior to authorizing permit-required confined space entries:

- intrinsically safe hand radio,
- 150 pound halon fire extinguisher,
- intrinsically safe flashlights, lamps, or lanterns rated for class I, division 1 hazardous atmospheres,
- additional respiratory protection as recommended by BE, and
- rescue webbing harness.

# B-1 LANCER

## INTEGRAL FUEL TANKS – FORWARD FUSELAGE (1B/1C)

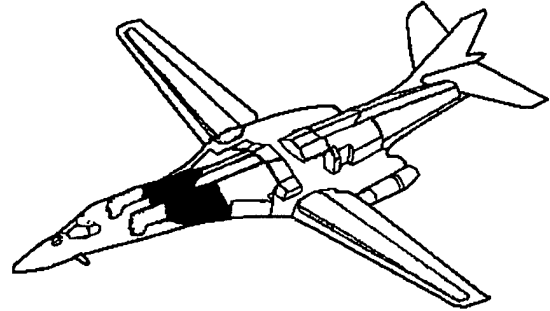

### SPACE DESCRIPTION

There are two forward fuselage fuel tanks (1B and 1C) on the B-1 aircraft that can be entered completely by maintenance personnel. Tanks 1B and 1C are identical, one is located on the right side of the forward fuselage and the other is located on the left side of the forward fuselage. These tanks are integral fuel tanks that have been built into the forward fuselage section of the aircraft. They are located aft of the forward intermediate fuselage tanks (#2 left/right). Each tank contains fuel lines and fuel components.

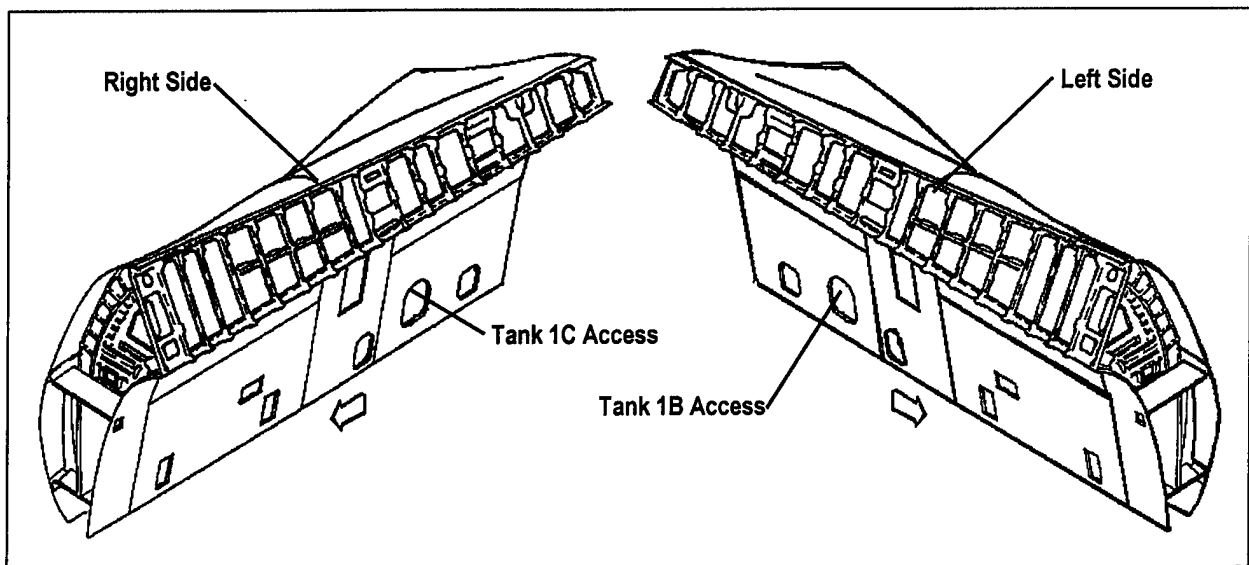

**Figure 2. Forward Fuselage Fuel Tanks**

### INNER DIMENSIONS

Height = 8.0'  
Length = 16.0'  
Depth = 4.0'

### ENTRY DIMENSIONS

Length = 1.5'  
Width = 2.0'  
(oval entrance)

[The depth is the distance from the entrance to the most distant point.]

## **SPACE ACCESS/INNER AREA**

Each forward fuselage fuel tank has a single access that is located on the side of the tank.

## **RECOMMENDED CLASSIFICATION**

Permit-required confined space.

## **JUSTIFICATION FOR CLASSIFICATION**

The forward fuselage fuel tanks are permit-required due to the following conditions:

- contains or has the potential to contain a hazardous atmosphere (e.g., fuel and its constituents), and
- has an internal configuration such that an entrant could be trapped or asphyxiated (e.g., limited space congested with fuel lines and support braces/ribs).

# B-1 LANCER

## INTEGRAL FUEL TANKS – AFT FUSELAGE (#4)

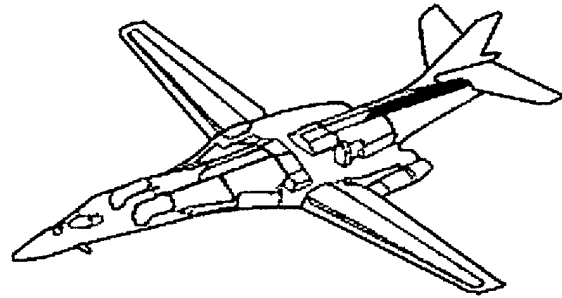

### SPACE DESCRIPTION

The aft fuselage fuel tank #4 can be entered completely by maintenance personnel. It is located in the center of the aft intermediate fuselage fuel tank #3 (aft tank), and behind the aft intermediate fuselage fuel tank #3 (forward tank). The aft fuselage fuel tank #4 is an integral fuel tank that has been built into the fuselage section of the aircraft. It contains fuel lines and fuel components.

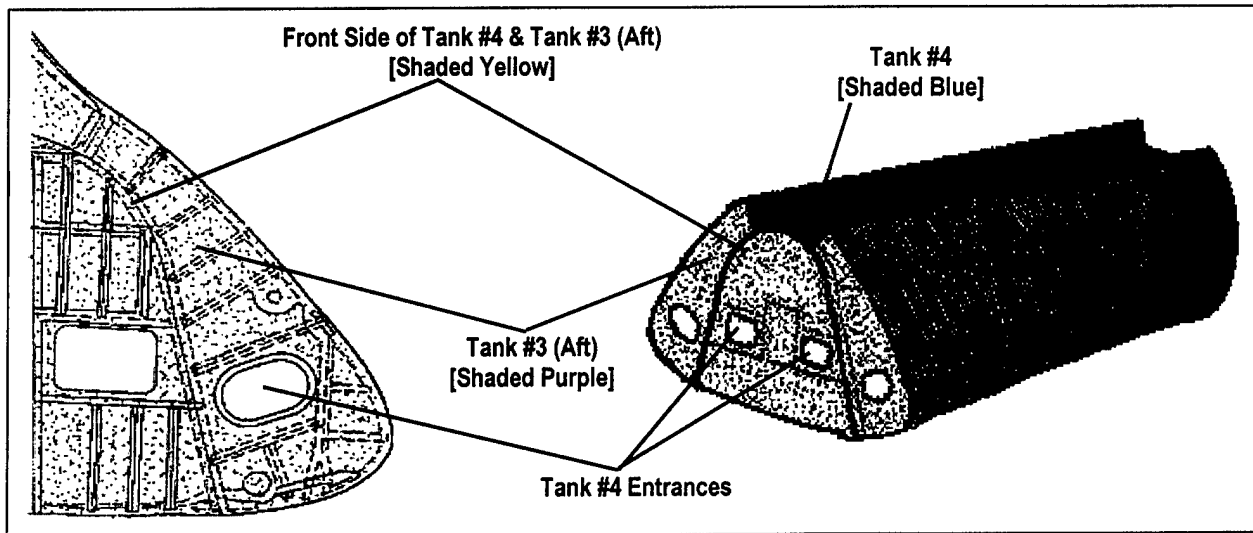

**Figure 3. Aft Fuselage Fuel Tanks**

#### INNER DIMENSIONS

Height = 8.0'  
Length = 10.0'  
Depth = 22.0'

#### ENTRY DIMENSIONS

1. Forward: Length = 2.5'    Width = 2.5'  
2. Forward: Length = 2.5'    Width = 2.5'  
(both entrances are square)

[The depth is the distance from the entrance to the most distant point.]

## **SPACE ACCESS/INNER AREA**

Aft fuselage fuel tank #4 is accessed from the weapons bay (the aft end of the bomb-bay) of the aircraft. This tank has two side entrances located at the front end of the tank.

## **RECOMMENDED CLASSIFICATION**

Permit-required confined space.

## **JUSTIFICATION FOR CLASSIFICATION**

The aft fuselage fuel tank #4 is permit-required due to the following conditions:

- contains or has the potential to contain a hazardous atmosphere (e.g., fuel and its constituents), and
- has an internal configuration such that an entrant could be trapped or asphyxiated (e.g., limited space congested with fuel lines and support braces/ribs).

# B-1 LANCER

## INTEGRAL FUEL TANKS – MAIN (LEFT/RIGHT)

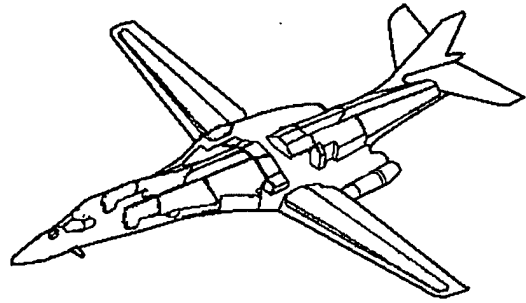

### SPACE DESCRIPTION

The main fuel tank contains two separate identical tanks (left and right) that can be entered completely by maintenance personnel. The two fuel tanks are located above the wheel well, and behind the forward intermediate fuselage tanks (#2 left/right). The main tank is an integral fuel tank that has been built into the fuselage section of the aircraft. Each tank contains fuel lines and fuel components.

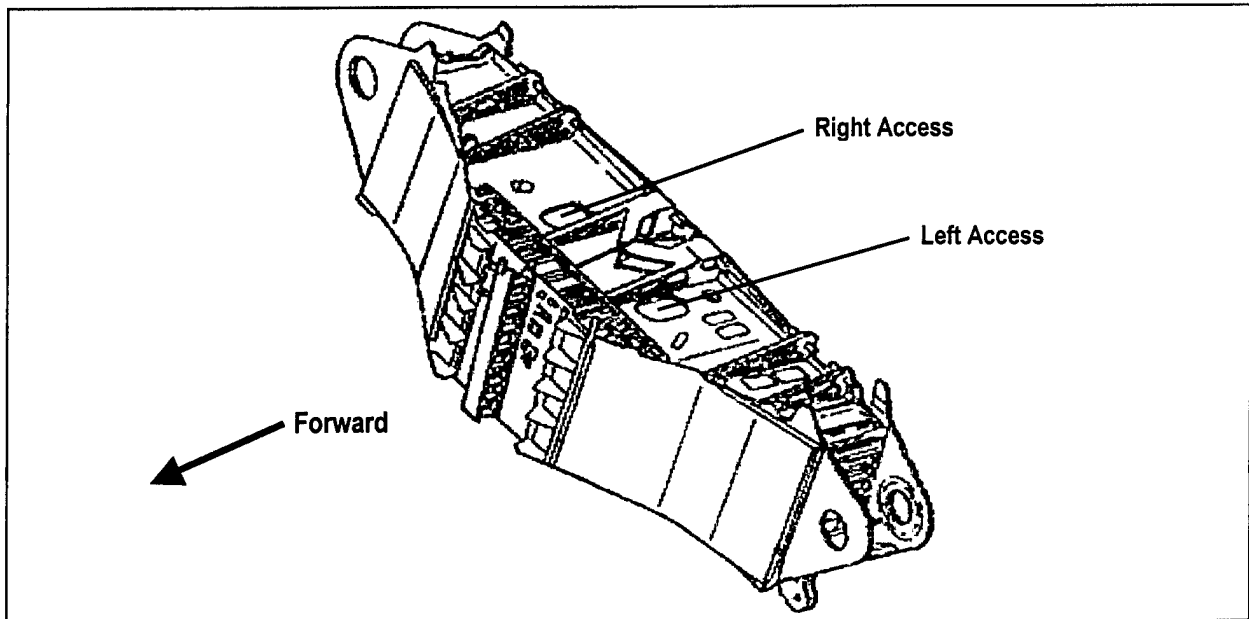

Figure 4. Main Fuel Tank

#### INNER DIMENSIONS

Height = 7.0'  
Length = 11.0'  
Depth = 7.5'

#### ENTRY DIMENSIONS

Length = 1.5'  
Width = 2.0'  
(oval entrance)

[The depth is the distance from the entrance to the most distant point.]

## **SPACE ACCESS/INNER AREA**

Each main fuel tank has a single side entrance that is accessed through the wheel well. The entrance is located on the aft wall of the space.

## **RECOMMENDED CLASSIFICATION**

Permit-required confined space.

## **JUSTIFICATION FOR CLASSIFICATION**

The main fuel tanks are permit-required due to the following conditions:

- contains or has the potential to contain a hazardous atmosphere (e.g., fuel and its constituents), and
- has an internal configuration such that an entrant could be trapped or asphyxiated (e.g., limited space congested with fuel lines and support braces/ribs).

# B-1 LANCER

## INTEGRAL FUEL TANKS – FORWARD INTERMEDIATE FUSELAGE (#2 LEFT/RIGHT)

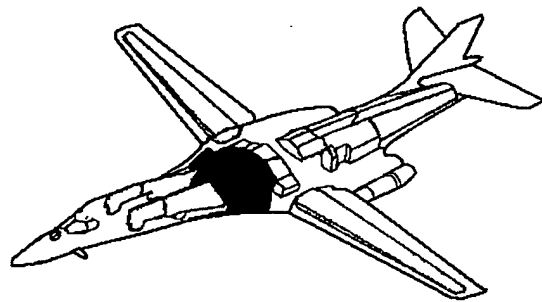

### SPACE DESCRIPTION

There are two identical forward intermediate fuselage fuel tanks (#2 left and #2 right) that can be entered completely by maintenance personnel. The two fuel tanks are located between the forward fuselage fuel tanks (1B/1C) and the main tanks (left/right). They are integral fuel tanks that have been built into the fuselage section of the aircraft. Each tank contains fuel lines and fuel components.

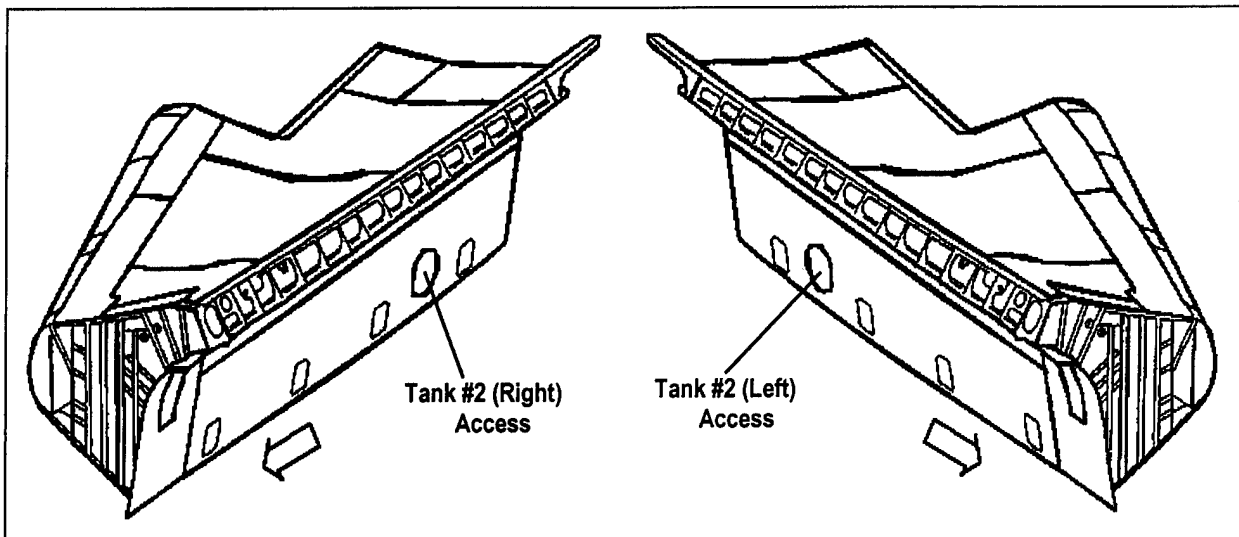

Figure 5. Forward Intermediate Fuselage Fuel Tanks

### INNER DIMENSIONS

Height = 6.0'  
Length = 16.0'  
Depth = 6.0'

### ENTRY DIMENSIONS

Length = 1.5'  
Width = 2.0'  
(oval entrance)

[The depth is the distance from the entrance to the most distant point.]

### SPACE ACCESS/INNER AREA

Each forward intermediate fuselage fuel tank has a single side entrance that is accessed through the weapons bay (the bomb-bay below the cockpit).

## **RECOMMENDED CLASSIFICATION**

Permit-required confined space.

## **JUSTIFICATION FOR CLASSIFICATION**

The forward intermediate fuselage fuel tanks are permit-required due to the following conditions:

- contains or has the potential to contain a hazardous atmosphere (e.g., fuel and its constituents), and
- has an internal configuration such that an entrant could be trapped or asphyxiated (e.g., limited space congested with fuel lines and support braces/ribs).

# B-1 LANCER

## INTEGRAL FUEL TANKS – AFT INTERMEDIATE FUSELAGE (#3 FORWARD)

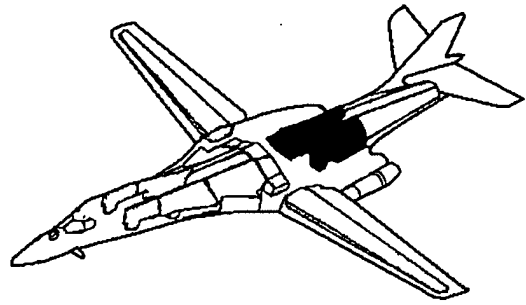

### SPACE DESCRIPTION

The aft intermediate fuselage tank #3 is divided into two separate tanks (forward and aft) that can be entered completely by maintenance personnel. Each tank has different dimensions and therefore is classified as separate spaces in this document.

The aft intermediate fuselage tank #3 (forward tank) is located behind the wheel well of the aircraft, in front of the aft intermediate fuselage tank #3 (aft tank). It is an integral fuel tank that has been built into the fuselage section of the aircraft. Each tank contains fuel lines and fuel components.

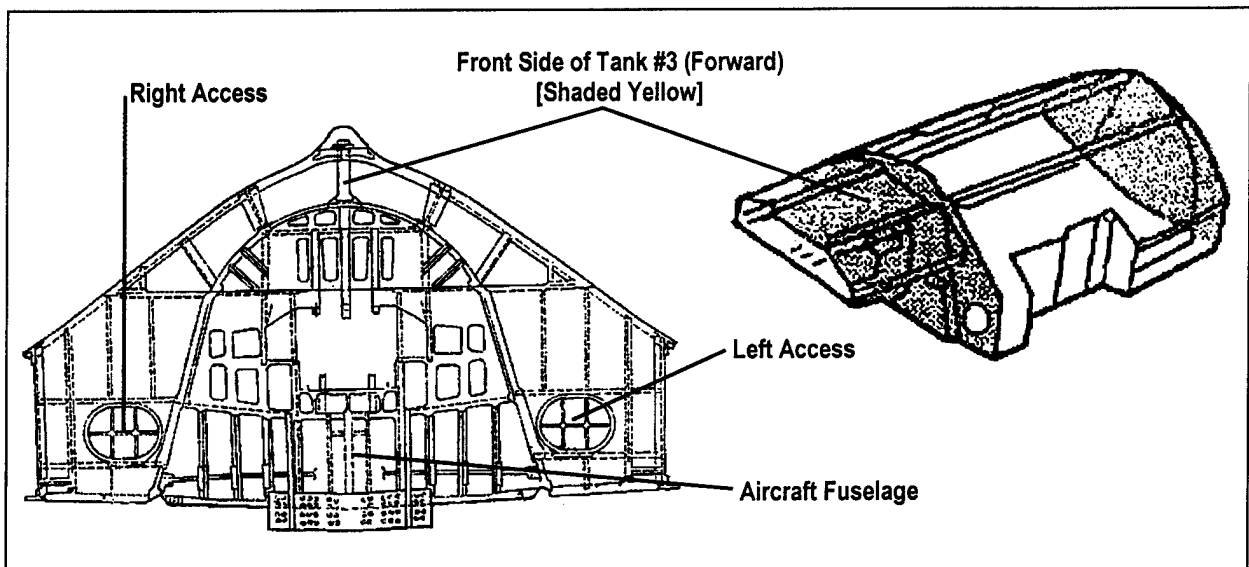

**Figure 6. Aft Intermediate Fuselage Fuel Tank #3 Forward**

### INNER DIMENSIONS

Height = 8.0'  
Length = 12.0'  
Depth = 20.0'

### ENTRY DIMENSIONS

1. Forward: Diameter = 2.0'
  2. Forward: Diameter = 2.0'
  3. Aft: Diameter = 2.0'
  4. Aft: Diameter = 2.0'
- (all entrances are circular)

[The depth is the distance from the entrance to the most distant point.]

## **SPACE ACCESS/INNER AREA**

The aft intermediate fuselage tank #3 (forward tank) has four side entrances. Two of the entrances are located on the forward wall, and are accessed from within the wheel well. The remaining two entrances are located on the aft wall, and are accessed from within the aft intermediate fuselage tank #3 (aft tank).

## **RECOMMENDED CLASSIFICATION**

Permit-required confined space.

## **JUSTIFICATION FOR CLASSIFICATION**

The aft intermediate fuselage tank #3 (forward tank) is permit-required due to the following conditions:

- contains or has the potential to contain a hazardous atmosphere (e.g., fuel and its constituents), and
- has an internal configuration such that an entrant could be trapped or asphyxiated (e.g., limited space congested with fuel lines and support braces/ribs).

# B-1 LANCER

## INTEGRAL FUEL TANKS – AFT INTERMEDIATE FUSELAGE (#3 AFT)

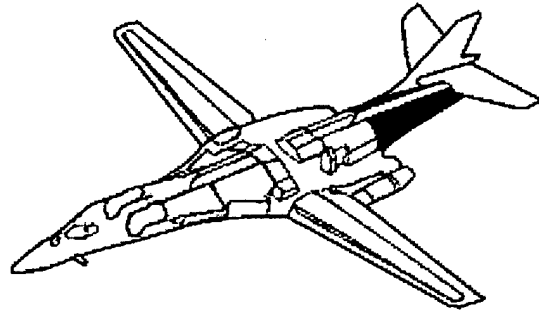

### SPACE DESCRIPTION

The aft intermediate fuselage tank #3 is divided into two separate tanks (forward and aft) that can be entered completely by maintenance personnel. Each tank has different dimensions and therefore is classified as separate spaces in this document.

The aft tank is located behind the aft intermediate fuselage tank #3 (forward tank). It is an integral fuel tank that has been built into the fuselage section of the aircraft. Each tank contains fuel lines and fuel components.

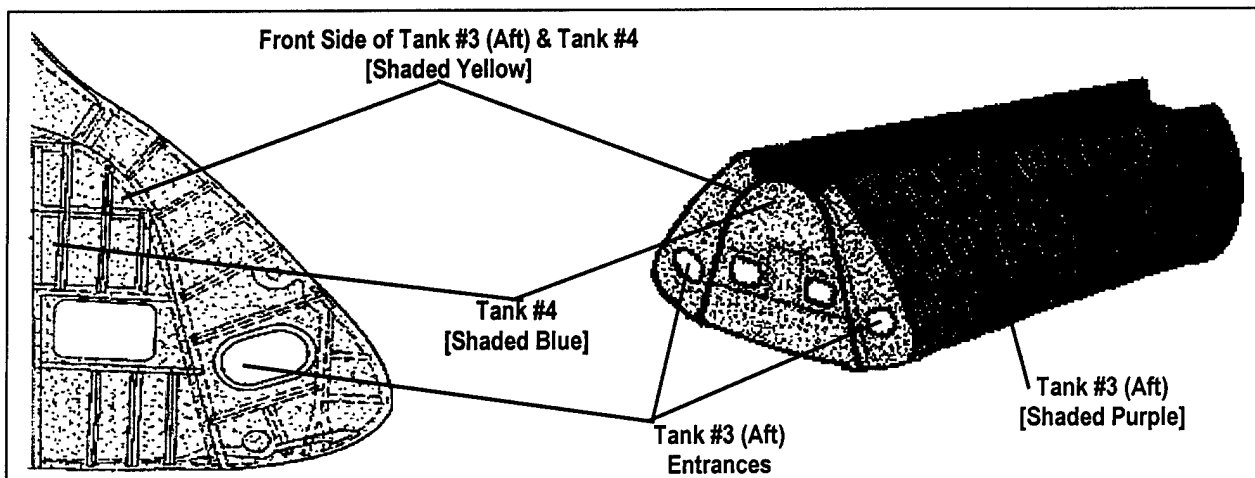

**Figure 7. Aft Intermediate Fuselage Fuel Tank**

### INNER DIMENSIONS

Height = 8.0'  
Length = 3.0'  
Depth = 22.0'

### ENTRY DIMENSIONS

1. Forward: Diameter = 2.0'  
2. Forward: Diameter = 2.0'  
(all entrances are circular)

[The depth is the distance from the entrance to the most distant point.]

## **SPACE ACCESS/INNER AREA**

The aft intermediate fuselage tank #3 (aft tank) has two side entrances located on the forward wall separating the forward and aft #3 fuel tanks. Each side (left and right) of the forward wall has a single entrance.

## **RECOMMENDED CLASSIFICATION**

Permit-required confined space.

## **JUSTIFICATION FOR CLASSIFICATION**

The aft intermediate fuselage tank #3 (aft tank) is permit-required due to the following conditions:

- contains or has the potential to contain a hazardous atmosphere (e.g., fuel and its constituents), and
- has an internal configuration such that an entrant could be trapped or asphyxiated (e.g., limited space congested with fuel lines and support braces/ribs).

# B-1 LANCER

## OVER-WING FAIRING (OWF) AREA

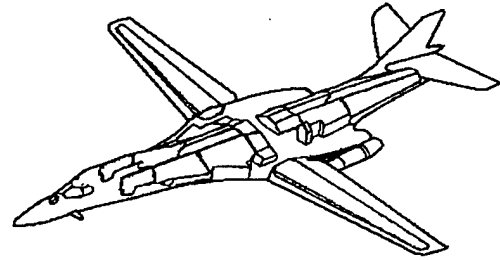

### SPACE DESCRIPTION

The B-1 aircraft has two over-wing fairing (OWF) areas located at the inboard end of each wing. The OWF area is the space between the wing and the fuselage that is created when the wings are in the forward position. It contains an automatic system of movable fairing surfaces that improves aircraft performance by maintaining a faired airflow surface at the wing root. The system also prevents wing-to-fairing interference when the wing is in motion. Maintenance personnel enter this space to perform normal maintenance activities and inspections. Maintenance personnel may also enter this space to access the fairing systems' two independent control loops, one for each wing. Each control loop consists of a dual electrical channel coupled to a hydraulic actuator.

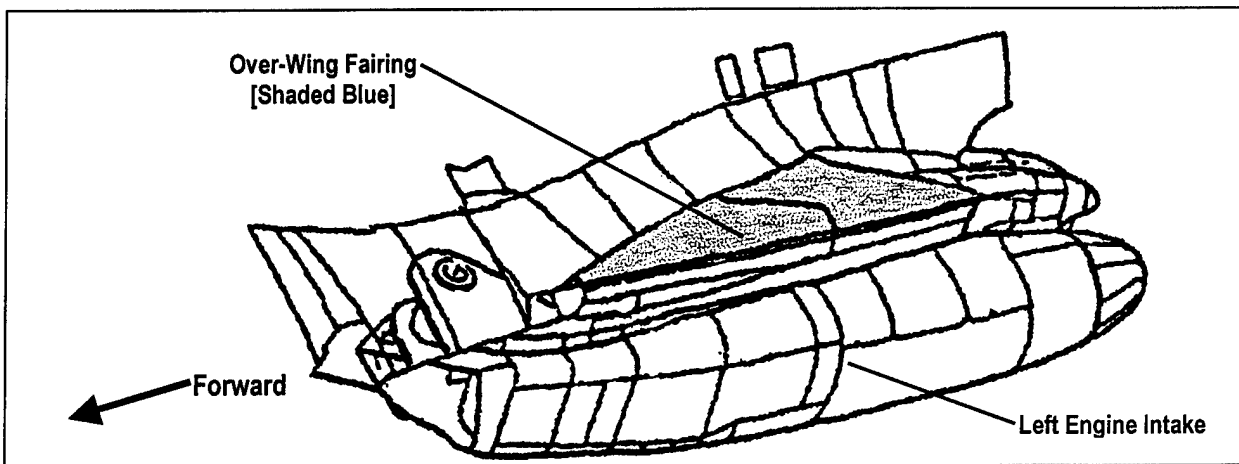

Figure 8. Over Wing Fairing

### INNER DIMENSIONS

Height = 3.5'  
Length = 15.0'  
Depth = 7.5'

### ENTRY DIMENSIONS

Length = 3.5'  
Width = 15.0'  
(irregular shaped entrance)

### SPACE ACCESS/INNER AREA

The OWFs are accessed from the outboard side of the space, through the open space between the wing and the fuselage of the aircraft (wing root area). This entry area can

vary in dimension depending on the position of the wing. The dimensions presented above represent the wing in the full forward position.

## **RECOMMENDED CLASSIFICATION**

Nonpermit-required confined space.

## **JUSTIFICATION FOR CLASSIFICATION**

The OWFs contain a variety of closed/contained systems that are not CREDIBLE potential hazards, and therefore are not permit-required confined spaces. The systems are hazardous if they are intentionally opened or a significant leak occurs. These conditions are unlikely due to personnel training and specific aircraft TOs and OIs that personnel are strictly required to comply with. The TOs and OIs govern procedures such as lockout/tagout and system checks prior to entering the various areas of the aircraft.

## **TASKS PERFORMED WITHIN THE SPACE**

Personnel from several work centers may enter the OWFs to perform both general and emergency maintenance activities. These work centers may include Aircraft Structural Repair, Non-Destructive Inspection Maintenance, ISO Dock, etc. The majority of activities conducted within this space are for inspections and routine scheduled maintenance only, and no chemicals are used. Flightline, depot, and other related activities are not referenced in this document. However, some tasks performed during aircraft structural repair and ISO Dock maintenance, may require the use of various solvents, cleaners, adhesives, paints, and primers. Only authorized materials, or materials that have been fully evaluated and approved by offices can be used within the OWFs.

# B-1 LANCER

## ENGINE INTAKES

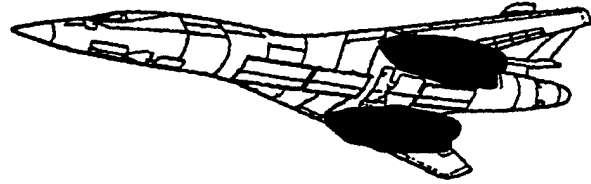

### SPACE DESCRIPTION

Each side of the B-1 aircraft contains a pair of engines encased in an engine intake. There are two engine intakes (four engines) on each aircraft. The intakes are separated by two stationary vanes that direct airflow to the engines. Air enters the engine intake through two external compression inlets with moveable flaps. Each external compression inlet directs air through the stationary vane to the engine. The engine intake space ends at the engine turbine blades. The space contains structural supports, vanes, fan blades, and engine components.

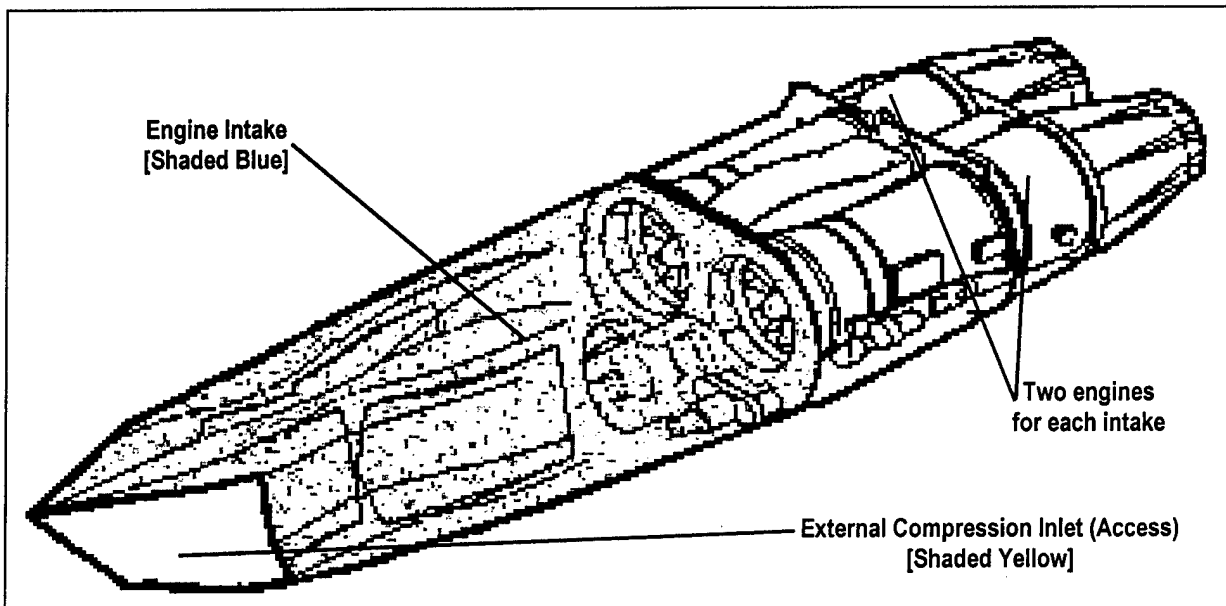

Figure 9. Engine Intakes

#### INNER DIMENSIONS

Height = 3.5'  
Length = 15.0'  
Depth = 3.5'

#### ENTRY DIMENSIONS

Length = 3.5'  
Width = 3.5'  
(irregular shaped entrances)

#### SPACE ACCESS/INNER AREA

The engine intakes are accessed from the side of the space, through the external compression outlets. There are a total of four external compression outlets, one for each engine.

## **RECOMMENDED CLASSIFICATION**

Nonpermit-required confined space.

## **JUSTIFICATION FOR CLASSIFICATION**

The engine intakes contain a variety of closed/contained systems that are not CREDIBLE potential hazards, and therefore are not permit-required confined spaces. The systems are hazardous if they are intentionally opened or a significant leak occurs. These conditions are unlikely due to personnel training and specific aircraft TOs and OIs that personnel are strictly required to comply with. The TOs and OIs govern procedures such as lockout/tagout and system checks prior to entering the various areas of the aircraft.

## **TASKS PERFORMED WITHIN THE SPACE**

Personnel from several work centers may enter the engine intakes to perform both general and emergency maintenance activities. These work centers may include Aircraft Structural Repair, Non-Destructive Inspection Maintenance, ISO Dock, etc. The majority of activities conducted within this space are for inspections and routine scheduled maintenance only, and no chemicals are used. Flightline, depot, and other related activities are not referenced in this document. However, some tasks performed during aircraft structural repair and ISO Dock maintenance, may require the use of various solvents, cleaners, adhesives, paints, and primers. Only authorized materials, or materials that have been fully evaluated and approved by SEG, CEF, and BE offices can be used within the engine intakes.

# **B-1 LANCER**

## **AFT ELECTRONICS BAY**

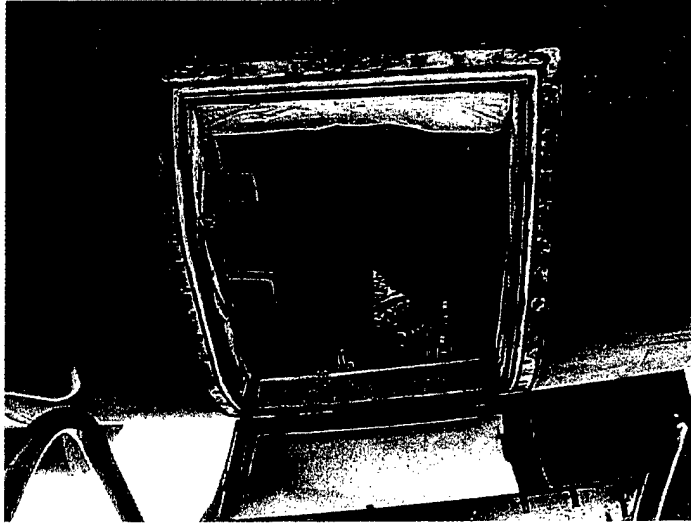

### **SPACE DESCRIPTION**

The Aft Electronics Bay is located on the tail section of the aircraft and requires a ladder to reach the access panel. It is approximately 4 feet in height. There are no fuel or hydraulic lines within the space. It contains numerous electronic and avionic systems.

### **RECOMMENDED CLASSIFICATION**

Nonpermit-required confined space.

### **JUSTIFICATION FOR CLASSIFICATION**

The space contains a variety of closed/contained systems (electronic, high-voltage) that do not present CREDIBLE potential hazards; therefore, it is not a permit-required confined space. The systems may be hazardous if they are unintentionally left on or open. These conditions are unlikely due to personnel training and specific aircraft TOs and OIs. The TOs and OIs govern procedures such as lockout/tagout and system checks prior to entering this space.

### **TASKS PERFORMED WITHIN THE SPACE**

Personnel from several work centers may enter the aft electronics bay to perform both routine and emergency maintenance activities. These work centers may include Aircraft Structural Repair, Non-Destructive Inspection Maintenance, Electro-environmental,

Avionics, and ISO Dock. The primary activities conducted within this space are inspections and routine scheduled maintenance without chemicals. However, some tasks performed during aircraft structural repair and ISO Dock maintenance, may require the use of various solvents, cleaners, adhesives, paints, and primers. Only authorized materials, or materials that have been fully evaluated and approved by SEG, CEF, and BE offices can be used within the aft electronics bay.