

REPORT DOCUMENTATION PAGE

Form Approved
OMB No. 0704-0188

The public reporting burden for this collection of information is estimated to average 1 hour per response, including the time for reviewing instructions, searching existing data sources, gathering and maintaining the data needed, and completing and reviewing the collection of information. Send comments regarding this burden estimate or any other aspect of this collection of information, including suggestions for reducing the burden, to Department of Defense, Washington Headquarters Services, Directorate for Information Operations and Reports (0704-0188), 1215 Jefferson Davis Highway, Suite 1204, Arlington, VA 22202-4302. Respondents should be aware that notwithstanding any other provision of law, no person shall be subject to any penalty for failing to comply with a collection of information if it does not display a currently valid OMB control number.

PLEASE DO NOT RETURN YOUR FORM TO THE ABOVE ADDRESS.

1. REPORT DATE (DD-MM-YYYY) 31102002	2. REPORT TYPE Proceeding	3. DATES COVERED (From - To)
---	------------------------------	------------------------------

4. TITLE AND SUBTITLE An improved Subsequent Burial Instrumented Mine	5a. CONTRACT NUMBER N0001402WX30017
	5b. GRANT NUMBER N/A
	5c. PROGRAM ELEMENT NUMBER 0602435N

6. AUTHOR(S) Sean Griffin, John Bradley, Maurice Thiele, Cuong Tran, Francis Grosz, Michael D. Richardson	5d. PROJECT NUMBER BE-782-001
	5e. TASK NUMBER
	5f. WORK UNIT NUMBER 74-6626-00

7. PERFORMING ORGANIZATION NAME(S) AND ADDRESS(ES) Naval Research Laboratory Marine Geoacoustics Division Stennis Space Center MS 39529	8. PERFORMING ORGANIZATION REPORT NUMBER NRL/PP/7430-02-8
--	--

9. SPONSORING/MONITORING AGENCY NAME(S) AND ADDRESS(ES) Office of Naval Research 800 North Quincy Street Arlington VA 22217-5000	10. SPONSOR/MONITOR'S ACRONYM(S) ONR
	11. SPONSOR/MONITOR'S REPORT NUMBER(S)

12. DISTRIBUTION/AVAILABILITY STATEMENT Approved for public release; distribution is unlimited

13. SUPPLEMENTARY NOTES Oceans 2002 MTS/IEEE Conference Proceeding

14. ABSTRACT Detection of buried mines using conventional sonars is difficult, especially in complex coastal environments, which complicates naval tactical decisions such as whether to hunt, sweep, or avoid a mined area. The U.S. Navy is therefore supporting research to develop and validate stochastic, time-dependent, mine burial prediction models. This research requires continuous monitoring of both mine behavior during burial and the near-Held processes responsible for burial. Modes of burial are generally separated into two broad categories: impact burial and subsequent burial (scour and fill, creep, liquefaction, and bedform modification). Omni Technologies, Inc. (OTI) and the Naval Research Laboratory (NRL) have developed instrumented mines that measure both subsequent mine burial behavior and the processes that initiate and effect burial. In this paper we describe new instrumented mines, including acoustic sensors used to measure burial and sensors used to measure mine orientation, azimuth and movement. Sensors and methods used to measure characteristics of surface gravity waves, direction and magnitude of bottom currents, turbulent flow near the mine, initiation of bedload motion, and sediment size and concentration in the water column are also described.

15. SUBJECT TERMS mine burial; burial instrumented mine; impact burial; subsequent burial; mine countermeasures; orientation sensors; flow sensors; pressure sensors; hydrophones
--

16. SECURITY CLASSIFICATION OF:			17. LIMITATION OF ABSTRACT	18. NUMBER OF PAGES	19a. NAME OF RESPONSIBLE PERSON
a. REPORT Unclassified	b. ABSTRACT Unclassified	c. THIS PAGE Unclassified	SAR	6	Michael D. Richardson
					19b. TELEPHONE NUMBER (Include area code) 228-688-4621

An Improved Subsequent Burial Instrumented Mine

Sean Griffin, John Bradley, Maurice Thiele,
Cuong Tran and Francis Grosz, Jr.

Omni Technologies, Inc.
7412 Lakeshore Drive
New Orleans, LA 70124
sgriffin@otiengineering.com

Michael D. Richardson
Marine Geosciences Division
Naval Research Laboratory
Stennis Space Center, MS 39529
mike.richardson@nrlssc.navy.mil

Abstract – Detection of buried mines using conventional sonars is difficult, especially in complex coastal environments, which complicates naval tactical decisions such as whether to hunt, sweep, or avoid a mined area. The U. S. Navy is therefore supporting research to develop and validate stochastic, time-dependent, mine burial prediction models. This research requires continuous monitoring of both mine behavior during burial and the near-field processes responsible for burial. Modes of burial are generally separated into two broad categories: impact burial and subsequent burial (scour and fill, creep, liquefaction, and bedform modification). Omni Technologies, Inc. (OTI) and the Naval Research Laboratory (NRL) have developed instrumented mines that measure both subsequent mine burial behavior and the processes that initiate and effect burial. In this paper we describe new instrumented mines, including acoustic sensors used to measure burial and sensors used to measure mine orientation, azimuth and movement. Sensors and methods used to measure characteristics of surface gravity waves, direction and magnitude of bottom currents, turbulent flow near the mine, initiation of bedload motion, and sediment size and concentration in the water column are also described.

I. INTRODUCTION AND HISTORY

Mining has proven to be an effective and economical means of both offensive and defensive warfare [1]-[3]. Mines have been used in nearly every conflict since the Revolutionary War and remain a probable weapon for any future conflicts. Mines are simple to build and deploy with very little risk but require sophisticated equipment to locate and significant cost and risk to counter. "In short, there is superior economy of force in the use of these weapons ...".[1]

One of the difficulties in mine countermeasures operations is the detection and classification of buried mines. Bottom mines are easily buried by scour from wave action or tidal currents, wave induced liquefaction, migrating sand dunes, or changes in seafloor morphology. These subsequent burial processes are dependant on sediment type, meteorological conditions and history, wave action, bottom currents, and mine properties (density, size, shape) [5]. Once buried, sonar detection is difficult, especially at the long stand off

distances required for mine hunting ships. Prediction of mine burial is also a critical input to tactical decision aids that determine sonar effectiveness, rates of clearance, or whether to hunt, sweep or avoid an area. The U. S. Navy is thus interested in studying and modeling the burial process to improve naval tactical decision aids.

Early work on subsequent mine burial used uninstrumented mine shapes which required diver observations and were subjective, expensive, and limited by diver availability. Especially problematic was the limited visibility and difficult logistics during storm events, when burial is most active. FWG (Forschungsanstalt der Bundeswehr für Wasserschall und Geophysik in Kiel, Germany) and much later Omni Technologies Inc. (OTI) and the Naval Research Laboratory (NRL) developed self-recording mines that use optical methods to record the mine burial state. The OTI/NRL mine improved on the FWG instrumented mine design by adding sensors that record changes in mine heading, roll, and pitch which are critical to the study of mine burial. Optical techniques have several drawbacks, however, such as sensor fouling from marine growth and the hydrodynamic effects on flow of the protuberances on the mine surface possibly enhancing mine burial. Neither of the early instrumented mine types has sensors to measure near-field processes responsible for burial but, notwithstanding, research using these mines has provided significant understanding of mine burial processes [5], [6].

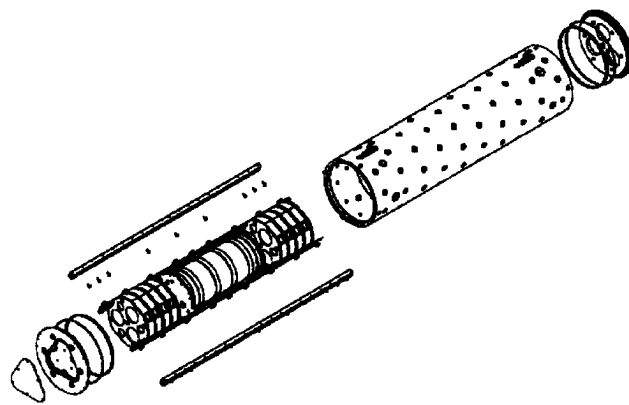

Figure 1 - Instrumented Mine Assembly Drawing

OTI and NRL have developed new subsequent burial instrumented mines that far exceed the capabilities of previous systems (Fig. 1). These instrumented mines are based on cylindrical mine housings constructed of Naval Aluminum Bronze. The improved instrumented mines use acoustic burial sensors that are mounted flush with the mine surface and provide increased coverage (112 versus 72 point sensors). As with the early NRL/OTI optical instrumented mine, roll, pitch, and heading are measured with accelerometers and electronic compasses. Accelerometers (3-axis) are used to detect mine motion that occurs when the mine falls into scour pits or the seafloor liquefies. Pressure sensors have been added to measure bottom pressure fluctuations associated with tidal changes and surface gravity waves. Added hydrophones can be used to support fleet mine hunting exercises and can also be used as an acoustic locator which responds when interrogated with a coded pulse. Coherent acoustic Doppler sensors have been developed to measure hydrodynamic flow rates around the mine. Calculated flow rates (mean and instantaneous) from the Doppler sensors and sediment concentration values calculated from acoustic backscatter of the burial sensors can be used to estimate rates of sediment transport. Temperature is logged for use in acoustic calculations. Sufficient data storage space and power is available for a one-year deployment.

II. IMPROVED SUBSEQUENT BURIAL INSTRUMENTED MINE

A. Mechanical Overview: The instrumented mines, which are designed to study subsequent burial, are cylindrically shaped (2.033 m long; 0.533 m diameter), weigh approximately 800 kg fully loaded, and have an average density of 1760 kg m^{-3} (Fig. 2). The housing is 2.54 cm thick on both ends and tapers to a 2.04 cm thickness at the center. This material was removed to reduce the density of the mine. A naval marine bronze was selected for the housing because of its high-density, non-magnetic, anti-fouling, and corrosion resistant properties. This material is strong and hard but easily machined.

A mechanical design goal for the outer housing was to eliminate protrusions, which might create added turbulent flow around the mine and alter the location and rates of scour. The sensors, however, require access to the external environment thus requiring each sensor to be recessed in the outer cylinder or end caps. The mine has 135 penetrations for sensors and connectors. In order to minimize the risk of leaks, every penetration has a minimum of 2 different watertight seals.

An inner frame is used to support the electronics and battery packs (Fig. 3). A roller system allows the 130 kg frame to be easily and safely inserted and extracted for servicing. The battery packs are located on each end of the frame to balance the load. At the center of the inner frame is a second pressure housing protecting the majority of the mine's electronics and storage media in case the watertight integrity of the outer

housing fails. All external electrical connectors are recessed on the front end cap and covered with a bronze plate maintaining the mine's smooth outer surface.

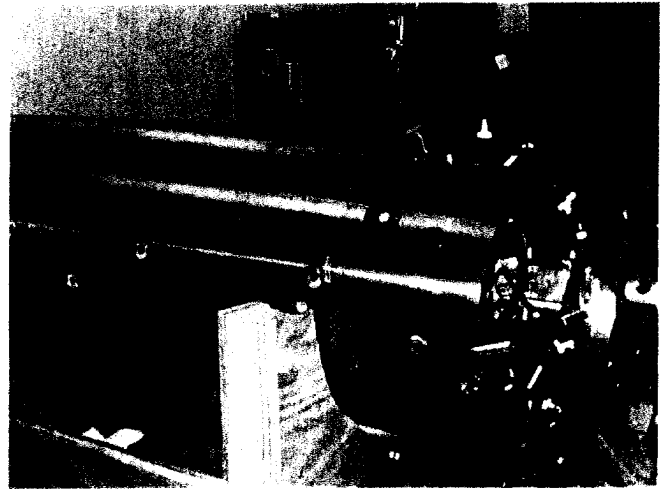

Figure 2 - Instrumented Mine during Assembly

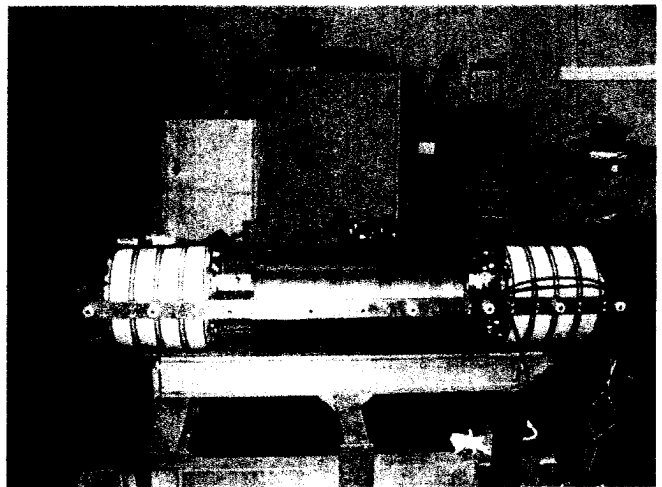

Figure 3 - Instrumented Mine Internal Assembly

B. Electronics Overview: The mine electronics is designed for flexibility and simplicity. Two relay boards external to the electronics canister act as wiring centers for all the sensors, thus reducing the number of wires attached directly to the acquisition system. The acquisition system electronics is used to select the active sensor, acquire data, and store that data to disk. The acquisition electronics is designed around a custom back plane consisting of 5 generic subsystem interface groups and 1 control system interface group. Each subsystem group consists of 3 slots that can be occupied by any subsystem type. The back plane provides power, a separate storage subsystem interface for each subsystem, a serial interface to the storage subsystem and inter-subsystem connectivity. Unique subsystem interface requirements such as sensor selection and analog inputs and outputs are provided on the

top of the subsystem boards. The back plane and cards use a 3U VME form factor to leverage off-the-shelf connectors, rails, slides, etc.

C. Burial Sensors: The burial sensors are unique and are more functional than the name implies. These transducers are designed to determine the burial state at each of the 112-transducer locations, allowing percent burial to be computed. Analysis of acoustic returns also allows characterization of changing geometric dimensions of the surrounding scour pit, detection of bedload transport, and estimation of suspended sediment size and concentration. Burial transducer signals might also be processed using coherent Doppler flow techniques to provide high-resolution flow measurements over the entire mine surface, though this function is not currently implemented.

The 112 burial transducers are distributed evenly across the surface of the mine with 6 sensors in each end cap and 10 rings with 10 sensors evenly covering the cylinder surface. Sensors in adjacent rings are oriented 18° with respect to each other to provide more effective coverage with a limited sensor count.

The burial transducer design includes a recessed piezoceramic element potted in urethane (Fig. 4). The element is 2.5 cm from the transducer face which is flush with the outer mine surface. Urethane, with an acoustic impedance similar to water, provides an acoustically transparent interface when immersed in seawater. A strong reflection from the transducer face therefore indicates sediment flush with the mine surface (i.e., the mine surface is buried). The 2.5 cm thick urethane provides sufficient range from the transducer face to eliminate interference between transmit and reflected signals, allowing the electronics time to switch from transmit to receive mode. The urethane thickness has created problems since many urethanes have high loss factors at 1.5 MHz and 3.0 MHz and selection of an appropriate urethane is critical. OTI tested numerous urethanes for attenuation characteristics in the selected frequency bands prior to final urethane selection (Fig. 5).

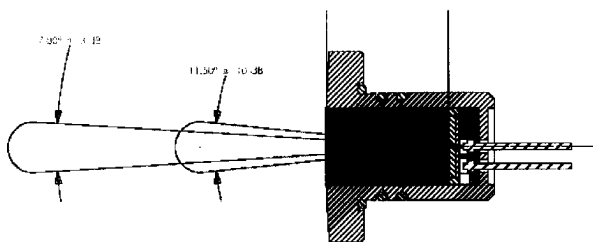

Figure 4 - Burial Transducer Cross-Sectional View and Beam Pattern

Basic burial transducer measurement techniques consist of emitting a 20 μ s wide or less pulse (either at 1.5 MHz or 3.0 MHz) and sampling for 1.33 ms (~1 m range). The transmit duration is less than the 34 μ s needed for an acoustic reflection from the transducer face given the ~1500 m s⁻¹

sound speed in urethane. The received signal is split into I and Q channels, mixed, low pass filtered and each channel's difference frequency sampled for a total signal bandwidth of 92 kHz (centered on the 1.5 MHz or 3.0 MHz carrier frequencies). This technique minimizes the data storage requirements and provides post-processing flexibility. Up to 100 measurements (user selectable) for each burial sensor per sampling interval can be acquired by the instrumented mine.

Determination of which sensors are buried below the sediment-water interface is performed in post-processing. The large differences in the impedance mismatch when sediment or water covers a transducer face leads to a significant acoustic reflection difference (at a range of 2.5 cm) for buried or unburied conditions. Post processing will allow the user to correct miss identified sensor burial conditions which result primarily from large suspended

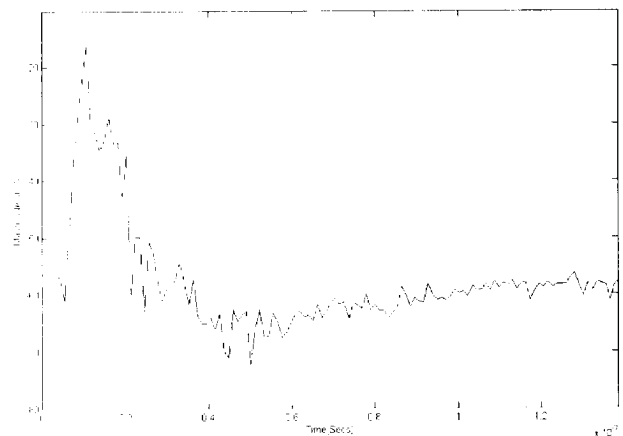

Figure 5 - Burial Transducer Reflection Magnitude in Air

sediment concentrations that may occur during storm events. Signal averaging is also possible, which improves the signal-to-noise and thus burial detection performance. Threshold detection limits for the range-gated returns can be selected during post processing based on user observations of burial signals and knowledge acquired from laboratory tests. Intervals between sampling events (using all 112 burial transducers) can be as short as 30 minutes.

Delineation of the dimensions of the scour pit surrounding the mine is determined from the same acoustic returns used for burial detection. The 2-way time required for a signal to reflect from the sediment-water interface together with the water sound speed are used to calculate the distance from each transducer face to the sediment. Threshold detection of the sediment water interface is much more complex than burial detection due to a number of conditions that will produce false range detections such as high sediment concentrations during storms, the presence of pelagic fauna, and the detection of multiples in buried transducers. A means to compare the calculated ranges to the mine orientation will also be required to provide a consistent coordinate system

(referenced to the sediment water interface) for scour pit measurements. A software program is planned to visualize the scour process with respect to time and mine orientation.

In addition, suspended sediment concentration and size distribution are measured from water column backscatter strengths using the burial transducers. This technique requires multi-frequency signals and thus the need for both 1.5 MHz and 3.0 MHz burial transducers. Thorne et al. provide a thorough description of these techniques and the methods of transducer calibration [7].

The initiation of bedload transport can also be estimated using correlation techniques applied to successive backscatter returns from the sediment surface. When bedload transport begins, a change in phase of the returned waveforms is expected as a result of changing fine scale seafloor roughness (i.e., the grains begin to move).

D. Flow Sensors: Two different flow sensor designs, both based on coherent acoustic Doppler techniques, are used to measure flow around the mine. Instantaneous flows are calculated for each ping and mean flows are calculated from a selected interval of instantaneous flow measurements. The first flow sensor, an acoustic Doppler current profiler (ADCP), operates at 1.5 MHz with 3 elements per sensor placed in a 2.9 cm diameter circle, 120° apart (Fig. 6). The elements are tilted inward at 30° angles and are recessed from the face of the transducer by 2 cm. The beam centers of each element cross approximately 2.5 cm above the transducer face. Measurement range of the ADCP is ~1 m from the transducer face. Since each element will provide a flow rate along its axis, geometric relationships can be used to obtain a 3 dimensional flow description relative to the axis of the mine. Three ADCP sensors are placed at 120° intervals around the circumference of the mine near each end cap for a total of six ADCP's. The sampling interval of the mine is user selectable and the I, Q sampling method is identical to that used for the burial transducers.

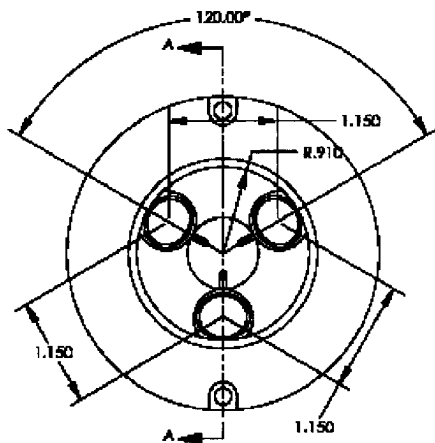

Figure 6 - ADCP Transducer Piezo Ceramic Element Configuration

The second flow sensor is a single element 500 kHz transducer. This sensor is designated as the Doppler flow sensor and six are placed on the mine, 1 on each end cap and 4 around the center of the mine cylinder, 90° apart (Fig. 7). Data acquisition and processing is identical to that of each ADCP channel. Since these are single element units with beams directed radially outward from the center of the mine, only flow normal to the transducer center axis is calculated.

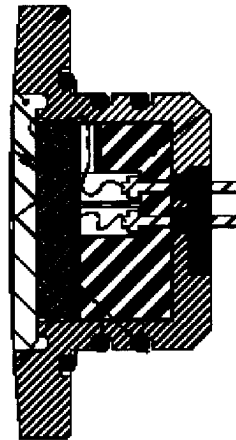

Figure 7 - Doppler Transducer Cross-Sectional View

The flow measurements are obviously important for monitoring bottom currents and turbulent flow induced by the presence of the mine but also for calculating sediment flux in and out of the scour pit when combined with the suspended sediment measurements. This provides a direct measure of the sediment volume moving in the mine's vicinity during storm events or during tidal cycles.

E. Orientation Sensors: Orientation measurements are critical to the analysis of subsequent mine burial processes. Motion before, during and after events provides insight into the burial process. Burial, hydrophone and flow sensors also require orientation information to compare successive measurements for transformations to a common coordinate system.

The instrumented mine orientation sensor consists of a standard, commercial off-the-shelf 3-axes flux gate compass and 3-axes accelerometer for roll and pitch. Heading accuracy is on the order of +/- 2.0° and roll and pitch accuracy is approximately +/- 0.5°. The selection of a non-magnetic housing allows use of a magnetic heading sensor as opposed to a fiber optic compass. A fiber optic compass would certainly be beneficial should the size and power efficiency issues of currently available units be resolved. Sampling intervals are selectable but should be at least as fast as the fastest sampling interval of the other sensors.

F. Pressure Sensors: Six pressure sensors monitor changes in mean water depth (primarily tidal) and surface gravity wave direction, height, and period. These transducers have a

range of 0 to 100 psi, giving a maximum water depth of ~45m with a sensitivity of approximately 1 mm (Fig. 8). Knowledge of surface wave conditions is required input to most scour and liquefaction mine burial models. Porous stainless steel filters insure sediment, shells, rocks, etc. do not damage the sensitive pressure sensor diaphragms. Pressure sensor measurements are programmed to occur at user selectable intervals and durations (e.g., for 15 minutes every hour). The sample rate is 10 samples per second for each pressure transducer.

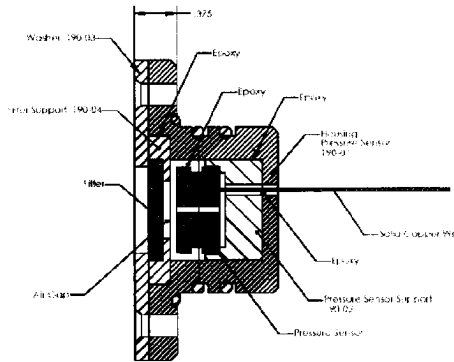

Figure 8 - Pressure Sensor Cross-Sectional View

G. Hydrophones: Hydrophones are used to measure acoustic energy impinging on the mine's surface from search and classification sonars (Fig. 9). Combined with the instrumented mine's burial and orientation measurements, this information is useful for post mission analysis of military training exercises. The hydrophones will also have the capability of responding to a coded pulse to determine mine health and location as well as for responding to search sonars during training exercises. It is envisioned that acoustic modems could be used on each mine to construct an intelligent minefield for fleet exercises.

The hydrophones are capable of receiving acoustic energy from 10 kHz to 100 kHz. The sampling method, however, band limits the signal to a user selected 10 kHz band located within the transducer's range. The hydrophones are monitored continuously for energy 20 dB (or other selected power level) above background noise. This triggers a storage event in which both pre and post trigger data (16-bit I and Q samples) is stored for all six hydrophones.

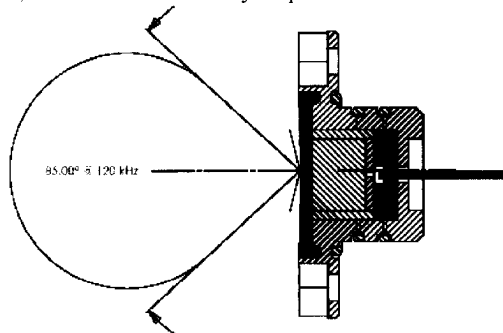

Figure 9 - Hydrophone Cross-Sectional View and Beam Pattern

H. Accelerometers: A +/- 4 G-rated, 3-axis accelerometer is used to constantly monitor acceleration. Accelerations associated with mine movement such as rocking and falling into scour pits and sinking during liquefaction can be detected. These sensors are located near the geometric center of the mine and mine movement associated with accelerations greater than 0.1 G will trigger a storage sequence whereby pre and post trigger accelerations are sampled and stored. The continuously monitored accelerometer provides immediate detection of motion that would normally be missed by periodic orientation measurements. Each accelerometer axis is sampled at 2929 samples per second.

I. Power and Storage Systems: Up to eight 72 alkaline D-cell battery packs, each weighing 16.5 kg, provide power for the mine. Battery packs are used in even multiples to provide redundant power and balance the mine's weight (Fig. 10). The eight battery packs can provide up to 365 days of energy depending upon the deployment scenario. The battery pack voltage begins at 12.8V (eight D-cells in series) and the mine stops functioning when the voltage falls below 6.5V. Battery packs are constructed from alkaline D-cells that are spot welded together with tin strips. D-cells were selected based on a beneficial cost to energy density ratio, ready availability, safety and ease of disposal.

Seven processors are used to distribute the processing load in order that only the necessary electronic systems draw power for each scheduled sensor data acquisition cycle. The multiple processor configuration also enables more capable mission planning algorithms that provide both fixed sampling modes as well as adaptive sampling modes that can detect specific events and trigger faster sampling intervals.

Four 20 Gigabyte hard drives provide non-volatile storage. These drives are interfaced to a single board computer running Linux. This system is generally off and only powered on when the cache subsystem memory is nearly full. Each power up sequence uses the next disk drive in the rotation sequence providing redundancy in case of failure.

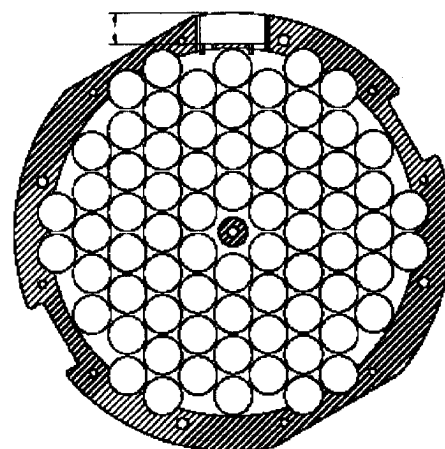

Figure 10 - Battery Pack Core

J. *Control Computer*: The instrumented mine control computer is a low power embedded computer system that powers each mine subsystem based on a mission scenario provided by an operator. This system controls power to all mine subsystems and distributes system time to all subsystems. Once powered, the subsystem will notify the controller when a measurement is complete and power can be removed. A timeout interval for each subsystem provides a means of overcoming a subsystem lockup. The system time uses a precision oscillator accurate to ± 2.5 minutes per year.

K. *Software*: Mission planning and configuration software provide the mine operator with a means to configure the deployment data acquisition plan. This process entails configuring each subsystem's configuration parameters such as operational frequency, ping rate, sample interval, ping count, sample count, etc. Once the mission scenario is complete, it is downloaded to the mine's control computer. At the time the mission scenario is loaded, a GPS time source is attached to accurately set the mine's control system time. Upon recovery, the mission planning and configuration software provides a means to offload data via a 100BaseT Ethernet connection. This procedure uses the ftp protocol and commercial software to move the data. The mine software is used to sequence through the mine's four disk drives. File naming conventions insure that unique file names are provided for each data packet.

III. PLANS

Field measurements have not been made since the instrumented mines are still in production. The first major experiments are planned for January-March 2003 offshore of Tampa, FL and in the fall of 2003 at the Martha's Vineyard Coastal Observatory as part of the ONR mine burial program. The instrumented mines will provide the ground truth measurements required by the modelers and those responsible for interpretation of the burial process. Two of the mines will be deployed in the Panama City, FL minefield for a 17-day deployment in August of 2002 for an initial test.

Acknowledgments

The four subsequent burial instrumented mines are being built under funding from the Office of Naval Research, contract numbers N00014-00-C-0431 and N00014-01-C-0055 (Roy Wilkins, Dawn Lavoie and Thomas Drake, program officers); the Naval Research Laboratory, contract number N00014-97-C-6001 (program element N062435N); and under a SBIR award from NAVSEA, contract number N00024-01-C-4039 (James Bloodsworth and William Kastner project managers). Roy Wilkins provided significant input on design requirements. We thank Mark Pecarero and Larry Ivy for their work on the transducer and the mechanical designs. Kim Benjamin provided guidance on transducer design issues and fabrication. Bruce Dewey at Howland Machine Shop fabricated the housings, Hughes Machine shop fabricated the many of the transducers parts, and Metal Fab South fabricated the battery packs. Jason Salsiccia wrote

much of the control and parsing software. David Maniscalco and Christopher Eiffert provided technician support.

References

- [1] Levie, Howard S., *Mine Warfare at Sea*, The Netherlands, Martinus Nijhoff Publishers, 1992.
- [2] Hartmann, Gregory K. and Scott C. Truver, *Weapons that Wait*, Naval Institute Press, 1991.
- [3] Thorne, Peter D. and Jon Taylor, "Acoustic Measurements of boundary Layer Flow and Sediment Flux", *J. Acoustic Soc. Am.* 108 (4), October 2000.
- [4] S. Griffin, J. Bradley, M.D. Richardson, K.B. Briggs and P.J. Valent, "Instrumented mines for mine burial studies," *Sea Technology*, vol. 42(11), pp. 21-27, 2001.
- [5] Richardson, M.D. and P. Traykovski. 2002. Real-time observations of mine burial at the Martha's Vineyard Coastal Observatory. 11 pps. *Proceedings of the 5th International Symposium on Technology and the Mine Problem*. Naval Postgraduate School, Monterey California, 22-25 May 2002.
- [6] Richardson, M.D. P.J. Valent, K.B. Briggs, J. Bradley, and S. Griffin. 2001. NRL Mine Burial Experiments. *Proceedings of the Second Australian-American Joint Conference on Technologies of Mine Countermeasures*, Sydney Australia, 27-29 March 2001. Defence Science and Technology Organization.
- [7] Richardson M.D. and K.B. Briggs. 2000. Seabed-Structure Interactions in Coastal Sediments. *Proceedings of the 4th International Symposium on Technology and the Mine Problem*. Naval Postgraduate School, Monterey California, 13-16 March 2000.