

REPORT DOCUMENTATION PAGE

Form Approved
OMB No. 0704-0188

Public reporting burden for this collection of information is estimated to average 1 hour per response, including the time for reviewing instructions, searching existing data sources, gathering and maintaining the data needed, and completing and reviewing this collection of information. Send comments regarding this burden estimate or any other aspect of this collection of information, including suggestions for reducing this burden to Department of Defense, Washington Headquarters Services, Directorate for Information Operations and Reports (0704-0188), 1215 Jefferson Davis Highway, Suite 1204, Arlington, VA 22202-4302. Respondents should be aware that notwithstanding any other provision of law, no person shall be subject to any penalty for failing to comply with a collection of information if it does not display a currently valid OMB control number. PLEASE DO NOT RETURN YOUR FORM TO THE ABOVE ADDRESS.

1. REPORT DATE (DD-MM-YYYY)		2. REPORT TYPE Technical Papers		3. DATES COVERED (From - To)	
4. TITLE AND SUBTITLE				5a. CONTRACT NUMBER	
				5b. GRANT NUMBER	
				5c. PROGRAM ELEMENT NUMBER	
6. AUTHOR(S)				5d. PROJECT NUMBER 1011	
				5e. TASK NUMBER 0011	
				5f. WORK UNIT NUMBER	
7. PERFORMING ORGANIZATION NAME(S) AND ADDRESS(ES) Air Force Research Laboratory (AFMC) AFRL/PRS 5 Pollux Drive Edwards AFB CA 93524-7048				8. PERFORMING ORGANIZATION REPORT	
9. SPONSORING / MONITORING AGENCY NAME(S) AND ADDRESS(ES) Air Force Research Laboratory (AFMC) AFRL/PRS 5 Pollux Drive Edwards AFB CA 93524-7048				10. SPONSOR/MONITOR'S ACRONYM(S)	
				11. SPONSOR/MONITOR'S NUMBER(S)	
12. DISTRIBUTION / AVAILABILITY STATEMENT Approved for public release; distribution unlimited.					
13. SUPPLEMENTARY NOTES					
14. ABSTRACT					
15. SUBJECT TERMS					
16. SECURITY CLASSIFICATION OF:			17. LIMITATION OF ABSTRACT A	18. NUMBER OF PAGES	19a. NAME OF RESPONSIBLE PERSON Leilani Richardson
a. REPORT Unclassified	b. ABSTRACT Unclassified	c. THIS PAGE Unclassified			19b. TELEPHONE NUMBER (include area code) (661) 275-5015

1691
1119

7 separate items enclosed

18110011

MEMORANDUM FOR PRS (In-House/Contractor Publication)

FROM: PROI (STINFO)

06 June 2002

SUBJECT: Authorization for Release of Technical Information, Control Number: **AFRL-PR-ED-TP-2002-138**
Greg Spanjers (PRSS) et al., "Resonant Operation of a Micro-Newton Thrust Stand"

38th AIAA Joint Propulsion Conference
(Indianapolis, IN, 7-10 July 2002) (Deadline = 09 July 2002)

(Statement A)

1. This request has been reviewed by the Foreign Disclosure Office for: a.) appropriateness of distribution statement, b.) military/national critical technology, c.) export controls or distribution restrictions, d.) appropriateness for release to a foreign nation, and e.) technical sensitivity and/or economic sensitivity.

Comments: _____

Signature _____ Date _____

2. This request has been reviewed by the Public Affairs Office for: a.) appropriateness for public release and/or b) possible higher headquarters review.

Comments: _____

Signature _____ Date _____

3. This request has been reviewed by the STINFO for: a.) changes if approved as amended, b) appropriateness of references, if applicable; and c.) format and completion of meeting clearance form if required

Comments: _____

Signature _____ Date _____

4. This request has been reviewed by PR for: a.) technical accuracy, b.) appropriateness for audience, c.) appropriateness of distribution statement, d.) technical sensitivity and economic sensitivity, e.) military/national critical technology, and f.) data rights and patentability

Comments: _____

APPROVED/APPROVED AS AMENDED/DISAPPROVED

PHILIP A. KESSEL Date
Technical Advisor
Space and Missile Propulsion Division

20021119 164

Resonant Operation of a Micro-Newton Thrust Stand

Capt. James P. Lake, Lt. Greg Cavallaro, Greg Spanjers
AFRL Propulsion Directorate, Edwards AFB, CA 93524

Paul B. Adkison
Sverdrup Inc., Edwards AFB, CA 93524

Michael J. Dulligan
ERC, Inc., Edwards AFB, CA 93524

AIAA-2002-3821

A computer automated technique suitable for evaluating micro pulsed plasma thruster (μ PPT) performance has been constructed and validated in the micro-Newton (μ N) force range. A swinging gate pendulum architecture oscillates with an 8 second period. Force is applied resonantly with oscillation each half period. The calibration method utilizes an electromagnet to pick up and drop masses to apply a known force in the same resonant fashion as thruster operation. The resulting equilibrium amplitudes are linearly proportional to the applied force with an intercept near zero. Thrust measurements are insensitive to short term random vibrational noise because of the resonant operation and are insensitive to long term drift because the amplitude measurements are relative, rather than absolute. The system is capable of resolving differences of $0.04 \mu\text{N}$ with an accuracy of $\pm 1.3\%$ for forces greater than $5 \mu\text{N}$.

Introduction

While various thrust stands have been built to measure μN thrust levels, most use the steady state displacement technique¹⁻¹³. In this method, a thrust stand at rest is displaced by the thruster force, with the record of that displacement compared to a means of calibration to determine the thrust level. While the means of calibration and displacement measurement vary, the operating principles remain the same. The accuracy of this technique can be adversely perturbed by forces, such as thermal drift and room vibrations, because the displacement is necessarily very sensitive.

A class of force measurement systems similar to the constant displacement type is the zero-motion class of thrust stands. In

this type, the lever arm position is sensed and the time derivative of position is used to drive an active damping circuit to hold the lever fixed in space. The current required to maintain zero motion is calibrated to provide force measurement; however, the same issues that apply to constant displacement measurements also apply to this class of thrust stand.

The thrust stand being discussed here operates on a different principle that minimizes the effects of external vibrations and thermal variations. It should be noted that operation and function of this thrust stand are specifically tailored to measure performance of the class of thrusters known as micro Pulsed Plasma Thrusters (μ PPT's), operating at $\sim 1 \text{ Hz}$. Rather than thruster operation displacing the indicator from the

stationary reference position as in constant displacement thrust stands, this thrust stand is operated in an oscillating, undamped mode. The thruster is then fired in resonance with the swing arm oscillation, such that the thruster is engaged for half of each thrust stand period.

Because the thrust is resonantly applied with swing arm motion, the amplitude of oscillation is amplified, facilitating measurement. The motion of the swing arm behaves as a forced harmonic oscillator, with appropriately insensitive response to external vibrational forces that are either random in nature, such as people walking in the vicinity of the operating thrust stand, or are periodic but are of sufficiently different frequency that harmonics do not efficiently couple to the motion of the swing arm, such as operation of vacuum pumps.

Further, this system is insensitive to thermal drift, as long as the total swing arm motion remains in the linear range of position detection. This is due to the relative measurement of noting the difference between oscillation maxima and minima to produce swing arm total amplitude, which does not vary if the center of oscillation drifts in time. This is in contrast to a common problem associated with the constant displacement class of thrust measurements. In this case, the measurement is absolute and referenced to a position that may drift in time because of thermal variation, for example.

The insensitivity to vibration and thermal drift of the system being discussed allows for extended periods of operational usefulness. The primary benefit is the capability of providing long-term trending of thruster performance, in contrast to the labor-intensive procedures for obtaining data from a steady state displacement thrust stand

that can monitor only one or a few impulse firings.

Milli-Newton Configuration

The vacuum chamber used for thrust measurements is 2.4 m (8 ft) in diameter with a length of 3.8 m (12.5 ft) for an internal volume of 17.2 m³ (628 ft³). Rough vacuum is achieved in the chamber with a roots blower, while operating pressures are maintained with two diffusion pumps using Dow Corning 704 oil. Chamber pressure before and during thruster operation is measured using an MKS cold-cathode gauge operated with a 937A MKS Gauge Controller. Chamber pressures during normal PPT operation are 3×10^{-5} to 6×10^{-5} Torr.

Thomas Haag of NASA Lewis Research Center^{12,13} developed the original swinging gate thrust stand for constant displacement (100 - 500 milli-Newton) thrust measurements. In the original configuration, the thruster was mounted to an insulative phenolic plate (right hand side of figure 1) while two Lucas Aerospace 5016-600 torsional pivots supported the aluminum swing arm structure. Roll and pitch were adjusted remotely using Hurst SAS 4004-014 stepper motors without encoders. Roll and pitch location were inferred from the number of steps commanded (as displayed on the Hurst EPC-015 control units). The motors were used to move the thrust stand until the swing arm was within the linear range of the LVDT. Power and instrumentation wires are connected to the swing arm, allowing plenty of slack near the pivot flexures to minimize resistance to thrust stand movement.

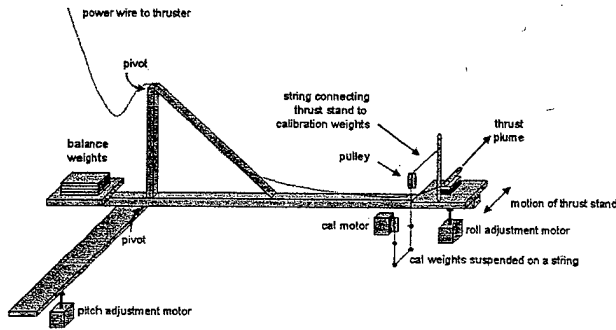

Figure 1. Original thrust stand configuration

After using an active damper circuit, calibrated weights (see figure 2) were applied to deflect the thrust stand. This deflection was recorded using a Servogor 111 paper strip-chart recorder, with the resulting displacements from several weights producing a calibration curve. The electromagnetic damper circuit was engaged during this entire time to minimize oscillatory motion. An example of the resulting calibration curve is illustrated in figure 3, along with typical zero drift seen during such an operation. The accuracy for this system of calibration was typically on the order of ± 1 milli-Newton. The drift in the zero point of the thrust stand and sensitivity to vibration leads to non-repeatable calibration curves and hysteresis.

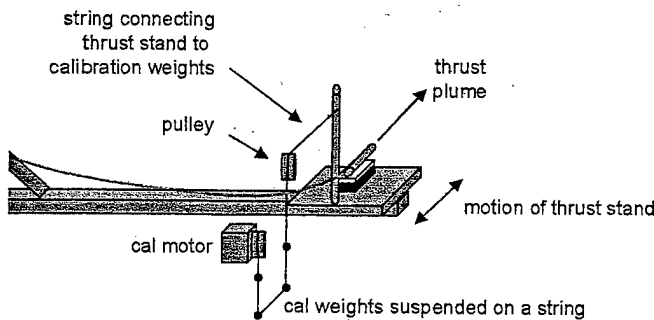

Figure 2. Milli-Newton calibration method

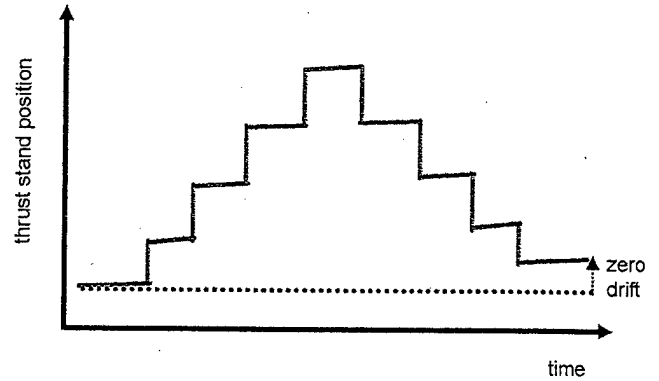

Figure 3. Original steady state calibration result

Micro-Newton Method

This thrust stand was upgraded, including the replacement of the stepper motors with Industrial Devices Corporation P21 stepper motors with encoders. The stepper motors are computer controlled via a National Instruments MID-7604 stepper motor controller and National Instruments PXI 7344 Motion Controller card. LVDT position is digitally recorded using a National Instruments MIO 6070E PXI multifunction I/O card. A new control program operating with Windows 98© and LabView 5.1® monitors the swing arm position and calculates the maximum, minimum, and resulting average swing arm position (offset from zero - see figure 3). To increase the swing arm amplitude due to a force input, a 5016-800 pivot with a lower spring constant replaced one of the Lucas Aerospace 5016-600 torsional pivots. Further increases in thrust stand sensitivity can be gained by replacing the remaining 5016-600 pivot as well. However, using the lower spring constant pivots reduces the maximum allowable thruster mass from 4.5 kg to 3 kg.

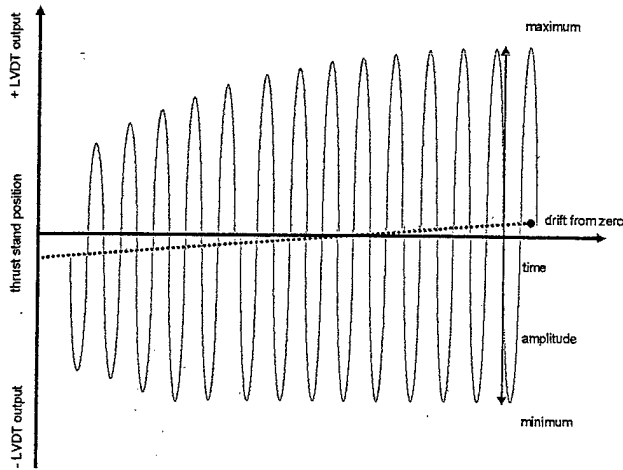

Figure 4. Drift in average location of thrust stand

To increase the sensitivity of the thrust stand to micro-Newtons of force, the steady-state displacement method was abandoned in favor of the forced-resonance oscillator method. This method intentionally oscillates the thrust stand without active damping, with the applied force (calibration or thruster) acting upon the thrust stand during the half-period of each oscillation (see figure 4). This method has several advantages over the steady-state displacement method. First, the applied force increases the already easily measured thrust stand amplitude to an easily measured few volts, making precise measurements simple. Second, the oscillating thrust stand is insensitive to transient forces (e.g., footsteps, automobiles, building HVAC systems). For example, the chamber atmosphere evacuation system produces visible vibrations to the electromagnet assembly without any adverse effect.

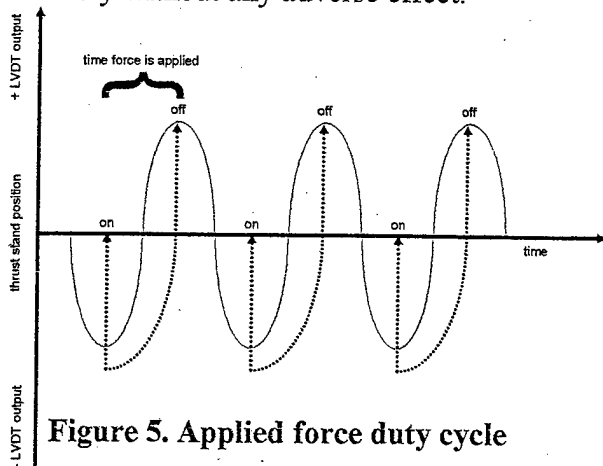

Figure 5. Applied force duty cycle

The effect of transient forces is very short compared to the 8 second period of the thrust stand, and over long data acquisition times reduced to zero. However, this insensitivity to transient forces inhibits measurement of high frequency thrust fluctuations as well. The time response of the thrust stand can be determined by examining the decay rate of the thrust stand amplitude (see figure 6).

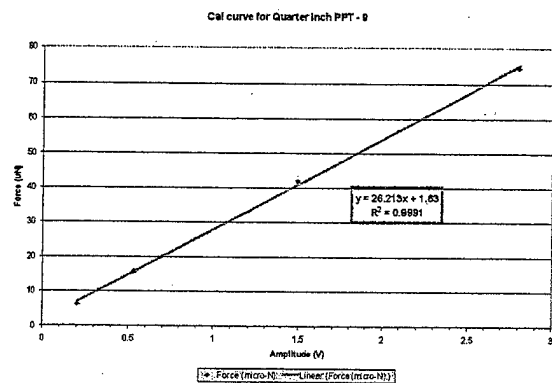

Figure 6. Decay rate of thrust stand amplitude

For example, to determine the time response for a given drop in thruster performance, the initial operating force is matched with its corresponding amplitude from the calibration curve. This is repeated for the lower thrust value as well. The time difference between these two points on the amplitude decay rate curve (figure 6) gives the amount of time required for the thrust stand to reach the new equilibrium amplitude. As seen in figure 6, the decay is an exponential curve.

The thrust stand position at any time during operation is measured by the LVDT and can be calculated in accordance with forced harmonic oscillator theory:¹⁴

$$m \frac{d^2x}{dt^2} + b \frac{dx}{dt} + kx = F(t) \quad (1)$$

where $F(t)$ is equal to the thrust applied for $\pi/2 < \theta < 3\pi/2$ (using figure 5) and zero otherwise.

Micro-Newton Configuration

To maximize the operating range of the oscillating thrust stand, the average location of the swing arm ($\text{max} - \text{min} / 2$) must be as close to zero as possible. Significant drift in the average location reduces the operating range of the thrust stand. Since the thrust stand oscillates, a large linear range is necessary to ensure accurate measurement of the thrust stand position. The thrust stand includes an LVDT with a Macro Sensors TIC-9000 LVDT readout that has a linear range of ± 3.5 mm. The greater the linear range available, the greater the force that can be measured with the thrust stand for a fixed system. If greater thrust levels are required, system mass or pivot flexure friction can be increased to reduce the sensitivity of the system.

If there is a drift in the average position of the thrust stand away from zero, no additional error or loss of accuracy will result as long as the entire swing arm motion remains within the linear range of the LVDT. Since only the maximum and minimum values of the swing arm position are used to calculate swing arm deflection amplitude, the absolute zero point does not influence the measurement (see figure 4).

Prior to performing a calibration and recording thrust measurements, an automated thrust stand balancing routine is activated. First, to ensure the maximum operating range is available for calibration and thrust measurements, the current average swing arm location is measured. If

the swing arm average location is calculated to be greater than 0.090 mm away from the center, the pitch motor is automatically commanded to provide coarse adjustment. The thrust stand is sensitive to adjustments in pitch, making large changes in average LVDT location easy through commands to the pitch motor. When the average LVDT location is greater than 0.036 mm but less than 0.090 mm away from zero small changes are accomplished through use of the roll motor. This process is repeated iteratively until the average thrust stand position is within 0.036 mm of zero, ensuring maximum operating range. After this procedure, zero-point drift is minimized due to the presence of permanent magnets within the pitch and roll motors. These magnets prevent uncommanded rotation of the motors, even when the holding torque is removed. Commanded changes in pitch and roll to the thrust stand may require re-calibration for maximum accuracy.

Once the thrust stand is centered about zero, the automatic calibration is started. The computer activates a modified (ferrite core removed) A.P.W. Co., Inc. 607R electromagnet at a 50% duty cycle to pick up the calibration mass (samarium cobalt magnet; 10 Vdc, 0.2 A). The electromagnet is suspended ~ 8 mm above a platter containing the calibration masses (see figure 7). Each mass is weighed using a Mettler Toledo AX105 Delta Range scale. The mass is changed through rotation of the platter so that the next mass is placed under the electromagnet. This operation is controlled automatically. The electromagnet is attached to the thrust stand by 0.13 mm (0.005 in) diameter monofilament fishing line, over a suspended aluminum pulley. The 3.38 cm (1.33 in) diameter pulley is attached to the thrust stand table via a 0.08 mm diameter tungsten wire (see figure 8). Special care was taken to ensure no

permanent magnets or ferrite materials were used near the electromagnet in the thrust stand structure, as this would influence the resulting force applied to the thrust stand during electromagnet activation.

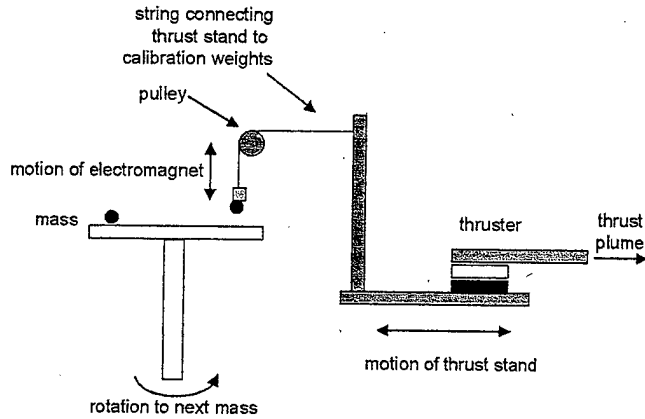

Figure 7. Attachment of electromagnet

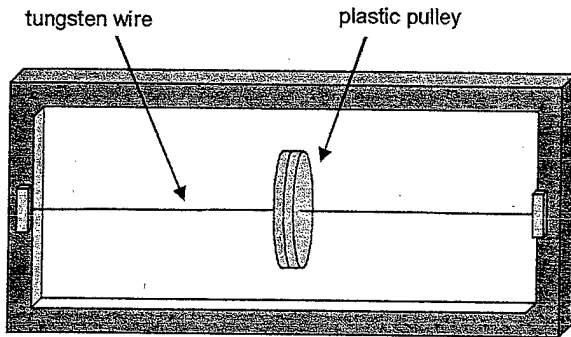

Figure 8. Pulley suspended using Tungsten wire

Verification that the electromagnet is only sensing the force from the selected calibration mass and not the other masses or any other ferrous material is determined by the following technique. The first step is to disable the electromagnet power supply and excite the thrust stand to the maximum amplitude. The baseline decay of the amplitude is then measured over time. The second step is to remove the first calibration mass and disable the calibration platform motor. This allows the electromagnet to continuously act on a region of theoretically no force. The thrust stand is then excited to the maximum amplitude and allowed to

decay with the electromagnet operating normally (50% of each period). The decay in amplitude is then recorded and compared to the baseline decay curve. Observation that these two decay curves are identical indicates that there is no measurable electromagnetic force acting on the thrust stand other than the selected mass during the calibration routine. A comparison between the baseline and electromagnet operating decay curves is shown in Figure 6. All magnet control is operated by the computer system.

The magnet operation is engaged when the thrust stand is moving in the same direction as the force that will be applied from the thruster (see figure 4). While the electromagnet is powered by a BK Precision 1760 Power Supply, the precise control for this is accomplished through a National Instruments 2565 PXI General Purpose Relay Switch controlled by the same LabView 5.1® code.

The code then examines the resulting amplitude of each swing cycle. These values are stored in a data array. The last fifteen values are constantly monitored to determine if the amplitude has reached an asymptotic limit. This is determined by calculating the variation in the amplitudes over the last fifteen cycles. The variation in thrust stand amplitude is calculated as the difference between the most recent two amplitude measurements.

This variation is then stored into another array. When all of the last fifteen variation values in the array are less than a determined tolerance, convergence is assumed for the force applied and the process is repeated for the remaining calibration masses. The entire calibration process typically is complete in less than 1.5 hours. The resulting time trace

of amplitudes for a calibration is shown in figure 9.

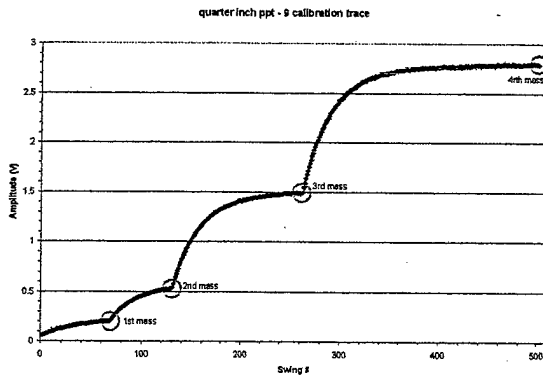

Figure 9. Convergence for calibration masses over time

A calibration curve is then created plotting the force imparted upon the thrust stand as a function of the converged amplitudes (from figure 9). A typical thrust stand calibration is shown in figure 10. For the masses used, sensitivity of the thrust stand is from 1 to 150 micro-Newtons. Higher thrust levels may be attained by replacement of the thrust stand flexure pivots with higher spring constant pivots. Alternately, lower thrust levels may be measured through the use of lower spring constant pivots. As seen in figure 10, the resulting thrust stand calibration is linear described by a slope of 26.213 $\mu\text{N/V}$ and an intercept of 1.63 μN . The corresponding quality of this curve fit has an R^2 value of 0.9991.

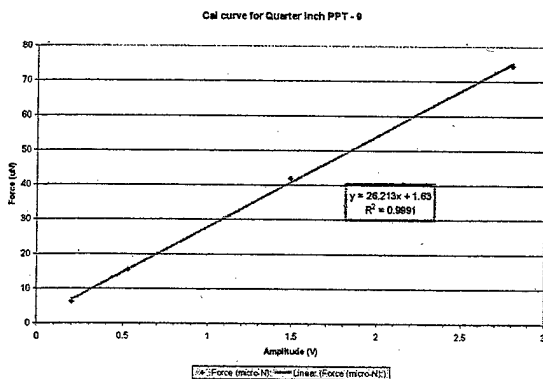

Figure 10. Resulting linear calibration.

Error Analysis

Thrust stand calibration has two dominant sources of measurement error: voltage reading from the LVDT through the Macro Sensors TIC 9000 to the National Instruments PXI 6070E multifunction I/O card and the error in the initial mass measurement from the Mettler Toledo AX105 Delta Range scale. The Macro Sensors TIC 9000 has a voltage output linear with LVDT displacement for a range of ± 3.5 mm. Maximum voltage output for the LVDT is ± 5 volts DC.

The PXI 6070E is a 12 bit volt reader card, capable of detecting ± 5 volts DC. Minimum detectable resolution for the PXI 6070E is therefore 2.4 mV. The uncertainty in the voltage measurement for the smallest converged amplitude (for the smallest calibration mass) is approximately 0.5% compared to 0.05% for the largest converged amplitude (for the largest calibration mass). For the linear range of the LVDT and the current thrust stand flexures, this corresponds to an amplitude of 1.7 micro-meters, or an approximate thrust resolution of 0.04 micro-Newtons.

The calibration masses are measured several times for a statistical average value. The resolution of the Mettler Toledo AX105 Delta Range scale is 0.01 mg. Current calibration masses range from 0.4 mg to 10.0 mg. Mass error thus ranges from 2.5% for the smallest mass to 0.1 % for the largest mass. The uncertainty in mass for the smallest calibration masses is thus the dominant error. This error can be reduced through use of more accurate scales.

REFERENCES

1. Woodruff, J.R., Chisel, D.M., "Test Stand for Precise Measurement of Impulse and Thrust Vector of Small Attitude Control Jets," NASA Technical Note D-7402, Washington, D.C., August 1973, pp. 1-36.
2. Cubbin, E.A., Ziemer, J.K., Choueiri, E.Y., Jahn, R.G., "Pulsed Thrust Measurements Using Laser Interferometry," AIAA 96-2985, 1996.
3. Wilson, M.J., Bushman, S.S., Burton, R.L., "A Compact Thrust Stand for Pulsed Plasma Thrusters," IEPC 97-122, August 1997.
4. Genovese, A., Steiger, W., Tajmar, M., "Indium FEEP Microthruster: Experimental Characterization in the 1-100uN Range," AIAA 01-3788, June 2001.
5. Boccaletto, L., d'Agostino, L., "Design and Testing of a Micro-Newton Thrust Stand for FEEP," AIAA 00-3268, June 2000.
6. Gamero-Castano, M., Hruby, V., Martinez-Sanchez, M., "A Torsional Balance that Resolves Sub-Micro-Newton Forces," IEPC 01-235, October 2001.
7. Nicolini, D., Chesta, E., Gonzalez del Amo, J., Saccoccia, G., Hughes, E., Oldfield, S., "FEEP-5 Thrust Validation in the 10-100 uN Range with a Simple Nulled Pendulum Thrust Stand: Integration Procedures," IEPC 01-288, October 2001.
8. Marcuccio, S., Genovese, A., Andrenucci, M., "Experimental Performance of Field Emission Microthrusters," Journal of Propulsion and Power, Vol. 14, No. 5, 1998.
9. Ziemer, J., "Performance Measurements Using a Sub-Micronewton Resolution Thrust Stand," IEPC 01-238.
10. Bonnet, J., Marque, J., Ory, M., "Development of a Thrust Balance in the MicroNewton Range," 3rd International Conference on Spacecraft Propulsion, 2000.
11. Cubbin, E.A., Ziemer, J.K., Choueiri, E.Y., Jahn, R.G., "Laser Interferometric Measurements of Impulsive Thrust," Review of Scientific Instruments, 68(6):2339-2346, 1997.
12. Haag, T., "Thrust Stand for Pulsed Plasma Thrusters," Review of Scientific Instruments, 68(5):2060-2067, 1997.
13. Haag, T., "PPT Thrust Stand," AIAA-95-2917, 31st Joint Propulsion Conference, July 10-12 1995, San Diego, CA.
14. Symon, K., Mechanics, 3rd ed., Addison-Wesley Publishing Co., Reading MA 1971