



INSTITUTE FOR DEFENSE ANALYSES

**Quiet Supersonic Platform (QSP)  
Materials and Structures Focus Group  
Meeting, 26 June 2001**

Editors:  
Andrea Hartman  
William Hong  
Lisa Veitch

July 2001

Approved for public release;  
distribution unlimited.

IDA Document D-2627

Log: H 01-001472

## Report Documentation Page

<b>Report Date</b> 01JUL2001	<b>Report Type</b> N/A	<b>Dates Covered (from... to)</b> -
<b>Title and Subtitle</b> Quiet Supersonic Platform (QSP) Materials and Structures Focus Group Meeting, 26 June 2001	<b>Contract Number</b>	
	<b>Grant Number</b>	
	<b>Program Element Number</b>	
<b>Author(s)</b>	<b>Project Number</b>	
	<b>Task Number</b>	
	<b>Work Unit Number</b>	
<b>Performing Organization Name(s) and Address(es)</b> Institute for Defense Analyses 4850 Mark Center Drive Alexandria, Virginia 22311-1882	<b>Performing Organization Report Number</b>	
<b>Sponsoring/Monitoring Agency Name(s) and Address(es)</b> DARPA/TTO 3701 N. Fairfax Dr. Arlington, VA 22203-1714	<b>Sponsor/Monitor's Acronym(s)</b>	
	<b>Sponsor/Monitor's Report Number(s)</b>	
<b>Distribution/Availability Statement</b> Approved for public release, distribution unlimited		
<b>Supplementary Notes</b> The original document contains color images.		
<b>Abstract</b>		
<b>Subject Terms</b>		
<b>Report Classification</b> unclassified	<b>Classification of this page</b> unclassified	
<b>Classification of Abstract</b> unclassified	<b>Limitation of Abstract</b> SAR	
<b>Number of Pages</b> 237		

**This work was conducted under contract DASW01 98 C 0067, Task DA-2-1822 for DARPA/TTO. The publication of this IDA document does not indicate endorsement by the Department of Defense, nor should the contents be construed as reflecting the official position of that Agency.**

**© 2001, 2002 Institute for Defense Analyses, 4850 Mark Center Drive, Alexandria, Virginia 22311-1882 • (703) 845-2000.**

**This material may be reproduced by or for the U.S. Government pursuant to the copyright license under the clause at DFARS 252.227-7013 (NOV 95).**

INSTITUTE FOR DEFENSE ANALYSES

IDA Document D-2627

**Quiet Supersonic Platform (QSP)  
Materials and Structures Focus Group  
Meeting, 26 June 2001**

Editors:  
Andrea Hartman  
William Hong  
Lisa Veitch



## **PREFACE**

This document was prepared for the Defense Advanced Research Projects Agency in response to a task entitled “Quiet Supersonic Platform (QSP) Program Assessment.”



# CONTENTS

I.	INTRODUCTION.....	I-1
II.	DARPA QSP FOCUS GROUP MEETING ON MATERIALS AND STRUCTURES—SUMMARY .....	II-1
	A. QSP Program Overview .....	II-1
	B. DARPA Multifunctional Synthetic Materials Program .....	II-2
	C. Air Force Research Laboratory Programs—Materials and Manufacturing Directorate .....	II-3
	D. AFRL—Air Vehicles Directorate .....	II-4
	E. Structures and Materials Technologies for High-Speed Flight Vehicles .....	II-5
	F. 3-D Metals .....	II-5
	G. Designing with Materials .....	II-6
	H. Discussion .....	II-6
	Glossary.....	GL-1
	APPENDIX A—SUMMARY CHARTS FROM DISCUSSION GROUPS	
	APPENDIX B—PRESENTATION CHARTS	
	APPENDIX C—LIST OF ATTENDEES	



## I. INTRODUCTION

This document records presentations and discussions which took place at the Defense Advanced Research Projects Agency (DARPA) Focus Group meeting entitled “Materials and Structures Needs in the Quiet Supersonic Platform (QSP) Program,” held at the Institute for Defense Analyses (IDA) on 26 June 2001. The purpose of this meeting, sponsored by DARPA’s Dr. Richard Wlezien, was to discuss the current and emerging materials technologies and processes which might be applicable to meeting the structural and performance goals of the QSP Program. This program seeks to develop a supersonic aircraft that creates an initial shock pressure rise of only  $0.3 \text{ lb/ft}^2$ , achievable through a combination of shaping techniques and weight reduction, alleviating sonic boom effects and allowing for unrestricted supersonic flight over land.

The goal for this Focus Group meeting was to encourage interaction and dialogue among academic, commercial, and government representatives concerning possible materials and structures utilization within the QSP Program. Much of the group’s discussion centered on newly developed materials and their potential structural applicability under the demanding flight conditions entailed by the goals set forth in the QSP Program.

The following written summary of these presentations and preliminary discussions give an overview of the concepts illustrated by the opening speakers. Readers are encouraged to look at the presentations for details regarding the technologies of interest.

After these initial presentations, the attendees were divided into three separate groups for more detailed discussions centering upon several questions posed by the meeting organizers. Charts enclosed in Appendix A of this document illustrate the summary outcome of these small-group deliberations. Appendix B contains the charts from the invited presentations given by various participants. The charts show various innovative materials and structures programs conceived and implemented by the participants’ respective organizations and their colleagues.

Meeting attendees included government personnel active in the QSP Program, experts in the fields of materials and structures, and representatives from major aerospace companies. Appendix C is a list of attendees and their contact information.

We wish to thank the Focus Group participants for their insights and efforts and hope that this document will help DARPA to assess the possibility for the subsequent application of the diverse materials and structural concepts discussed at this meeting to the QSP Program, as well as set the stage for subsequent meetings relating to similar topics.

Rich Wlezien

Lisa Veitch

## **II. DARPA QSP FOCUS GROUP MEETING ON MATERIALS AND STRUCTURES—SUMMARY**

### **A. QSP PROGRAM OVERVIEW**

Rich Wlezien from DARPA's Tactical Technology Office (TTO) began the focus group meeting by introducing the aims of the QSP Program. Those undertaking this 2-year program seek to study technologies which could be incorporated into an aircraft design meeting exceptional limits and goals for speed, weight, range, and boom generation. The challenging primary QSP requirement is producing an initial sonic boom shock strength of no more than 0.3 lb/ft<sup>2</sup>. To fulfill this requirement, a vehicle will likely have thin wings (2 percent), be very long (high fineness ratio), and employ low-density structures. QSP system goals, after the initial sonic boom mitigation, include the following:

- 100,000-lb gross takeoff weight (GTOW)
- Cruise speed: Mach 2.4
- 6,000 nmi unrefueled range
- 20-percent payload weight fraction
- Stage 3 noise standards compliant.

Additional derived goals of the program consist of:

- Lift/drag ratio = 11
- Thrust specific fuel consumption = 1.05 lb/(lb-hr)
- Engine thrust/weight = 7.5
- 40-percent fuel weight fraction
- 40-percent empty structural weight fraction.

Dr. Wlezien commented that materials and structures represent an area of the QSP Program which has received very little attention thus far, and further emphasis is necessary to achieve such a low structural weight fraction and maintain safe high-speed flight. The aim of this program is not the development of radically new materials, but rather an integration of technologies that can be incorporated today. In addition, he

described the current program structure, which incorporates three branches: QSP technologies development undertaken by small companies and universities, airframe systems, and propulsion systems contractors. A coordinated effort is necessary to address goals such as the empty weight fraction, which in past supersonic aircraft has been considerably larger than 40 percent due primarily to engine sizing. The relatively infrequent opportunities that now seem to be available for design of new supersonic aircraft also complicate the job of incorporating past “lessons learned.”

The Air Force has done studies that extrapolate today’s technology, much of it gained from the National Aeronautics and Space Administration (NASA) High Speed Research (HSR) program, to design a notional Mach 2.4, 32,000 lb payload Future Strike Aircraft with a range of 6,000 nmi. Its 427,000-lb GTOW, however, makes it an expensive vehicle that would be difficult to market to a potential user. The QSP Program, therefore, seeks to lower GTOW to 100,000 lb, while maintaining a 20,000-lb payload. At the time of this meeting, the program was halfway through the first year of its 2-year duration. DARPA will soon solicit the airframe companies for proposals for the second year of the program in order to help put together a more comprehensive effort.

Last, Dr. Wlezien discussed the advantages of foamed metallic structures in aircraft manufacturing. These advantages include their potential for cost-effective fabrication and their utility, both structurally and functionally, as an aid to laminar flow and thermal dissipation.

## **B. DARPA MULTIFUNCTIONAL SYNTHETIC MATERIALS PROGRAM**

Leo Christodoulou of DARPA’s Defense Sciences Office (DSO) spoke concerning new materials systems and synthetic multifunctional materials (SMFM) which could potentially reduce parasitic aircraft structural weight. Ideally, the entire aircraft structure would either serve additional functions or be eliminated. Relevant DSO structural concepts include

- Power structures
- Actuating and sensing structures
- Survivable structures
- Autogenous (self-healing) structures
- Autophagous (self-consuming) structures
- Thermal control structures.

Structural Amorphous Materials (SAM), another materials class that Dr. Christodoulou discussed, presents no long-range order or grain boundaries. These “metallic glasses” can be cast in large pieces, like conventional metals. As these substances deform, more of the material participates in the deformation process (hence processes such as shear band localization are prevented), creating dynamic toughness as the structure is loaded.

Dr. Christodoulou next explained the Accelerated Insertion of Materials (AIM) Initiative, intended to increase the speed of material insertion into new systems and to reduce the cost and risk of doing so. To promote use of state-of-the-art materials, AIM would organize existing materials knowledge into a Web-based system. Through this knowledge base, designers could acquire all the information that they would need to make a materials choice for their particular project. Dr. Christodoulou suggested in conclusion that although he had discussed some concepts that are far from actual implementation, this Web-based materials system is closer to becoming a reality for use by designers.

### **C. AIR FORCE RESEARCH LABORATORY PROGRAMS— MATERIALS AND MANUFACTURING DIRECTORATE**

Representing the Air Force Research Laboratory (AFRL) Materials and Manufacturing Directorate, Edward Hermes presented an overview of the current Air Force Materials and Manufacturing Technology, which would have relevance for the supersonic flight arena. The specific technologies of interest for structural and propulsion systems include the following:

- High-temperature poly matrix composites (PMCs)
- Carbon-carbon materials
- Thermal management materials
- High-fidelity analysis tools
- Processing for dimensional control
- Integrated High-Performance Turbine Engine Technology (IHPTET)
- Life prediction/high-cycle fatigue.

Dr. Hermes additionally pointed to current AFRL programs affecting structures and propulsion, such as:

- Composites affordability initiative
- Metals affordability initiative

- Forging supplier initiative
- Casting supplier initiative
- Laser shock peening
- Engine rotor life extension.

Last, Dr. Hermes identified issues that prevent the utilization of innovative materials, namely lack of confidence in materials models and affordability and access barriers.

#### **D. AFRL—AIR VEHICLES DIRECTORATE**

Dr. David Pratt from the Structures Division of the AFRL's Air Vehicles Directorate discussed QSP issues from a structural perspective. He defined the main structural issues to be:

- Embedded engine and aft decks
- Lightweight structures
- Design/analysis—probabilistic methods
- Aeroelasticity
- Mission-adaptable structures.

Dr. Pratt discussed various programs underway that were applicable to the above-listed categories:

- Ceramic exhaust-washed thermal structures
- Combined acoustic and thermal testing facilities
- Advanced Lightweight Affordable Fuselage Structures (ALAFS) Program
- Composites Affordability Initiative
- Ultra-lightweight structures program.

Dr. Pratt commented on the possibility of utilizing Active Aeroelastic Wings (AAW); High L/D Active (HiLDA) Wings; and additional adaptive structures, such as leading edges and inlets, as possible means to fulfill the QSP goals. At this point, he introduced Maj. Brian Sanders to speak further about adaptive structures designs.

Maj. Sanders briefly identified three adaptive structures concepts of interest. The first, the Smart Wing Program, has been demonstrated with actual componentry at Mach 0.8. Second, the Smart Aircraft and Marine ProjectS demonstratiON (SAMPSON) program, most useful at supersonic speeds, would use shape-memory alloys to modify

flow in an inlet. Third, energy harvesting is a concept in which thermal energy from the aircraft skin would be exploited to drive actuation systems.

## **E. STRUCTURES AND MATERIALS TECHNOLOGIES FOR HIGH-SPEED FLIGHT VEHICLES**

Dennis Dicus and Michael Nemeth of NASA's Langley Research Center gave an overview of some of the technologies stemming from the HSR Program, as well as current NASA research projects which are useful for high-speed flight. The key issue regarding airframe materials technology during the HSR Program was the lack of a long-term, high-temperature materials database for High-Speed Civil Transport (HSCT) airframes. In particular, the increase of cruise speeds from Mach 2.0 to 2.4 introduces significant additional challenges and issues for structural materials.

Technologies resulting from the HSR Program that are still under consideration for high-speed aircraft include lightweight wing and fuselage structures with variable stiffness distributions and the use of composite materials made from the PETI-5 polymer system. Beyond HSR Program research, NASA has looked at the Vacuum-Assisted Resin Transfer Molding (VARTM) Process, potentially a low-cost process because there is no need for an autoclave, and metal/polymer matrix composite hybrid materials, which offer improved fatigue life and in-plane damping. In addition, advanced aluminum alloys offer strength-toughness advantages necessary for Mach 2 flying conditions. Friction stir-welded joints improve on traditional riveted joints in the areas of weight, cost, and performance. Other materials and structure concepts that NASA has considered and which might be used in high-speed flight projects include Al-Mg-Sc alloys; new titanium alloys; titanium honeycombs, four-sheet sandwiches, and truss-core sandwiches.

## **F. 3-D CELLULAR METALS**

Haydn Wadley of the University of Virginia illustrated the possibilities offered by three-dimensional (3-D) cellular metals, an area of rapid growth over the last 10 years. These cellular metals can be divided into two subcategories, stochastic materials, such as metal foams, and periodic metals, encompassing prismatic materials and lattice or truss structures. Metal lattices, with densities spanning 1–10 percent of the original solid metal, are a material form of interest to the aircraft industry. Truss structures allow for design to specifications and placement of the trusses in ways that achieve optimized geometries. Cellular metals are manufactured in various ways, such as templated or foaming solidification (liquid), metal fabric layup (solid), and templated condensation (vapor).

Dr. Wadley continued by discussing specific types of cellular metal structures, which can be formed in a variety of size scales. Woven metal microtubes offer efficient heat-transfer capability. An inexpensive approach to creating lattice structures uses tubes woven into metal sheets, which are then stacked, sprayed with a transient liquid-phase sintering/bonding agent, and heated. The result is a strong but flexible truss structure. Constructed cellular metals are a revolutionary and inexpensive means of creating trusses simply by pressing alternating nodes from a perforated metal sheet. Dr. Wadley's charts show different truss geometries, fabrication approaches and properties of structures fabricated from them.

## **G. DESIGNING WITH MATERIALS**

Tony Evans from Princeton University began by explaining the properties of metal foams and truss structures. Although inexpensive, metal foams have limited stiffness and strength, and periodic structures may be a better choice under loaded conditions. Optimized truss structures allow for pure tensile and compressive stresses, with no bending. In addition, the openings in the trusses allow for fluid flow to aid thermal management. Under bending conditions, trusses perform much better than foams and nearly as well as honeycomb structures; under compressive loads, trusses perform similarly to traditional heat-stiffened structures.

Trusses also hold possibilities as curved panels because of their light weight and as heat exchangers, by using a metal with high thermal conductivity to draw heat into the lattice, where it can easily transfer to a fluid flowing through the core.

Dr. Evans showed a brief movie demonstrating that when a 45-deg weaving technology was utilized to create a truss structure, the core material did not undergo shape deformation under bending loads; the failure mechanism was instead the plastic bending of the face sheet.

## **H. DISCUSSION**

Following the above-summarized presentations, the participants were divided into three groups for discussion of the following six questions:

1. How would a Mach number range (2.0–2.4) affect new requirements?
2. How would these materials and designs be demonstrated, and what would be the maturity level required to do this?
3. How would design practices need to change if current materials are used?

4. What are the manufacturing issues?
5. What are the aeroelasticity issues for this type of vehicle?
6. What is needed to do a probabilistic design criteria approach?

The resulting comments from the three groups are summarized in this document in Appendix A.

Following the outbriefings from the groups, Dr. Wlezien thanked the participants for the day's open discussion. He summarized the three major themes he felt had emerged from the small-group deliberations:

- The materials and structures issues appear to be more of an engineering problem than a science problem. Multifunctional concepts present a potentially large payoff for QSP-type applications.
- Mach 2.2 presents a critical, if somewhat blurry, juncture in materials selection. Mach 2.4 may still be preferred for military needs.
- A need for engineering materials data exists, but QSP can still pursue avenues such as scaling up materials and testing and utilizing probabilistic design methods.

Dr. Wlezien then asked for a report card from the group detailing the responses of the attendees to the day's activities. Furthermore, he stated that he had found the Focus Group to be valuable, and he would be willing to sponsor an additional meeting. Finally, he explained that he had purposefully not defined a specific outcome for this meeting in the hopes that the discussion process in the areas of materials and structures would be iterative, with potential for further focus at a subsequent modeling and simulation (M&S) meeting.



## GLOSSARY

AAW	active aeroelastic wing
AFRL	Air Force Research Laboratory
AIM	accelerated insertion of materials
ALAFS	Advanced Lightweight Affordable Fuselage Structures Program
DARPA	Defense Advanced Research Projects Agency
DSO	Defense Sciences Office
GTOW	gross takeoff weight
HiLDA	High L/D Active
HSCT	High-Speed Civil Transport
HSR	High-Speed Research Program
IDA	Institute for Defense Analyses
IHPTET	Integrated High-Performance Turbine Engine Technology
M&S	modeling and simulation
NASA	National Aeronautics and Space Administration
PMC	poly matrix composites
QSP	Quiet Supersonic Platform Program
SAM	structural amorphous materials
SAMPSON	Smart Aircraft and Marine ProjectS DemonstratiON Program
SMFM	synthetic multifunctional materials
TTO	Tactical Technology Office
VARTM	Vacuum-Assisted Resin Transfer Molding



## **APPENDIX A**

### **SUMMARY CHARTS FROM DISCUSSION GROUPS**



## GROUP I DISCUSSION SUMMARY

- QSP weight goal not achievable through airframe weight reduction alone
  - Much potential for weight reduction in systems
  - Need to identify and prioritize
  - Current systems generally driven by cost (COTS)
  - Multi use structures offer potential to integrate structure and systems weight

- Much weight (and cost) reduction potential in unitization and joining
  - Develop required design techniques
- Hybrid structure
  - Tailor materials and structural concepts to specific areas of structure
  - Truss core structure for high stiffness
  - Amorphous material for high strength and fracture toughness

- Interesting materials and structural concepts
  - Tycor
  - GLARE
  - Al-Li
- Probabilistic Design
  - Need to understand loads, fly behavior to avoid conservative design



- Foam material
  - G-1 level
  - Repeatability of properties
- Sandwich Construction
  - Industry having terrible time integrating
  - High speed machining
- AIM
  - Accelerated Insertion of Materials

- Structural weight
    - Small fraction of MTOW
  - “Low hanging fruit” in other areas
    - Manufacturing
      - Reduced Part Count
    - Systems
      - Electric } Integrated Multipurpose
      - Hydraulic } Distributed Systems
      - Environmental } Compact Hybrid Actuation
    - Landing Gear
      - Don’t go there
- DARPA Program

- System reliability } Can translate to weight
- System access }
- Bonded structure
  - Process intensive
  - Inspection
  - Surface preparation
- Design process
- Integration of full use of available technology
- Multifunctional structural components

- Amorphous metals
  - Fine grain structure
  - Strength, toughness
  - Perfect processing to get perfect microstructure
- Hybrid construction
- Aluminum lithium
  - Newer alloys
- Monolithic structure
  - Larger, fewer parts
  - Aircraft component level

## GROUP II DISCUSSION SUMMARY

- Materials readiness
  - Time for demo--flight vs. ground
  - Time for application
- Flutter/aeroelastic  must fly
  - Other  ground
- Drivers
  - Weight
  - Thermal load vs. temperature
  - Fatigue/durability/design life
  - Creep
  - Thermal management
  - Damage tolerance
  - Dissimilar joining
  - Processing
    - Forming, tolerances, design criteria, \$

## Mach?

- Civilian  $\Rightarrow$  little impact to go faster
- $M=2.0 \Rightarrow$  more materials options, lower risk
- Military  $\Rightarrow$  go faster until cost too much
- Composites  $\Rightarrow$  M 2.2 (better stiffness)
- Metallic sandwich  $\Rightarrow$  2.4+ active cool?
- Titanium  $\Rightarrow$   $M=2.7$ , but too heavy?

# Demo Approach

- TRL = 6?
  - Ground
    - Scale build up approach
    - Thermal, mechanical load cycling
    - Full scale component
  - Need AIM to reduce cost!!!
    - Proof/validation needed
  - Aeroelastic
    - Wind tunnel + fly
    - All flight conditions
- QSP
  - Design/sizing tools don't capture new structures concepts
    - Need FEM analysis
  - Invest in design/analysis processes to accelerate transition
    - “Relative Answer”
    - “Don't converge too quickly”

## Demo Approach (Cont'd)

- Scaling laws/linkages (more global issue—bigger than QSP)
- Revise V&V process
  - Scale build up approach
- QSP scale-up panel size
  - High fidelity instruments
  - Combined environment
- NDE/quality control
  - Design consideration
- Failure criteria
  - Convince industry first
  - Monte Carlo on components
  - Define acceptable failure rate

## Summary

- Discussed design drivers
- Mach trade
  - Benefit of higher speed not substantial for civilian
  - Composites good to Mach 2.2 (superior stiffness)
  - Metallics for  $M=2.2 - 2.7+$ 
    - Active cooling?
- TRL = 6 – requires full scale ground test for combined loads
  - Aeroelasticity must fly
- Must have AIM to reduce cost
- Need to develop design/analysis tools
  - Look for relative answers
  - Avoid convergence too quickly

## Summary (Cont'd)

- Develop scaling laws, V&V process
- Probabilistic failure criteria
  - Convince industry first

## QSP Recommendation

- Scale up testing of candidate materials/structures concepts
  - Combined environment
  - High fidelity instrumentation
- Develop design methods
- Subscale assembly/joining test
- Update design requirements and/or practices to take advantage of new M&S and processes

## GROUP III DISCUSSION SUMMARY

### Wing-Main

- Conductive
- Low CTE
- High strength, moderate stiffness
- Thermal flexibility
- Attachment of load-bearing surface with sub-structure
- Lightweight material that achieves high temperature fast

### Thin Wing

- Structured cellular
  - Robust to small damage (sensitivity)
- Need data in normal engineering formats
- Repair of structure?
- How manufactured?
- Unit loading to reser.?
  - Size panels
- Assembly!
- Active cooling?
  - Selective possibly
  - Basic structure—not likely
  - Some lamination flow benefit
- Adaptive Structure?
  - Yes—payoffs?

## Thin Wing (Cont'd)

- Free-form processing
  - Not thin wing weight competitive
  - Possibly cost issue
- Need high stiffness/weight ratio
- VARTM processing PETI-5
- Large unitized structure without fasteners
- Composite—best
- Be-Al-Mg alloys?

## Periodic Sandwich

- Tailored internal topology
  - Open cell—no corrosion
  - Cheap manufacturing (to honeycomb)
  - Material flexibility
  - Multifunctional
    - Thermal management
    - Adaptive structure
  - Damping/noise suppression (flutter/acoustic)
  - Damage containment
  - Controllable isotropy

## Multifunctional Structures

- Antennas
- Subsystems
  - Power/Batteries
  - Controls
  - ECS
  - Thermal management
  - Fuel
  - IVHM

## Periodic Sandwich or EEDS Sandwich?

- Compare to honeycomb
  - What compare “standard” or optimized.
- General Answers
  - Joining concepts, etc.
- “ilities”

## Probabilistic Methods

- Tools
- Events
- Materials = need lots more materials data

## Summary of Benefits

- Reduced Factor-of-Safety (1-2% GTOW)
- Multifunctional Structures (1-2%)
- Unitized Composites (4-5%)
- Improved MDO Structures/Materials (2-3%)
- Gust Load Alleviation (?)
- Probabilistic Design (5%)
- Tailored Anisotropy (1-2%)
- Build Innovative Structures and Test to Failure

## **APPENDIX B**

### **PRESENTATION CHARTS**





---

# **Structural Materials and Devices**

**L. Christodoulou**  
**DARPA/DSO**

B-1

# Scope of Activities

---



- 1. New Material Systems**
  - a) Ultralight materials**
  - b) Synthetic Multifunctional Materials**
    - i. Stochastic**
    - ii. Periodic**
  - c) Structural Amorphous Metals**
- 2. Accelerated Introduction of Materials**
- 3. Prognosis (Capability Prediction)**



---

**Synthetic Multifunctional Materials: *Structure +...***

**Agents: A. Crowson (ARO), S. Fishman (ONR)**

**Structural Amorphous Metals**

**Agents: D. Hardwick (AFRL), G. Yoder & W. Messick (ONR), and  
W. Mullins (ARO) and R. Dowding (ARL)**

# **Synthetic Multifunctional Materials (SMFM)**

---



## **Grand Challenge:**

**Create application-specific material systems with optimized functions by design.**

# Synthetic Multifunctional Materials



## Problem:

**“Structure” is Parasitic  
to the mission –**

**It provides a platform  
for payload, sensor  
communications, etc.**



## Solution:

- **Eliminate**
- **Give structure other functions!!**

**Structure +...**

B-5

# The Problem



**Fact: Structure constitutes a large fraction of total system weight**

B-6

System	Total (lb.)	Structure (lb.)	Struct. Fract.	Payload (lb.)	Payload Fract.
Sender	10	5	50%	2	20%
F-18E/F	66,000	34,900	53%	13,700	21%
747-400	800,000	384,500	48%	285,000	36%
Satellite			19%		34%
Microstar (goals)	86 gms.	22.5 gms.	26%	18 gms.	21%

# Synthetic Multifunctional Materials: Program Vision

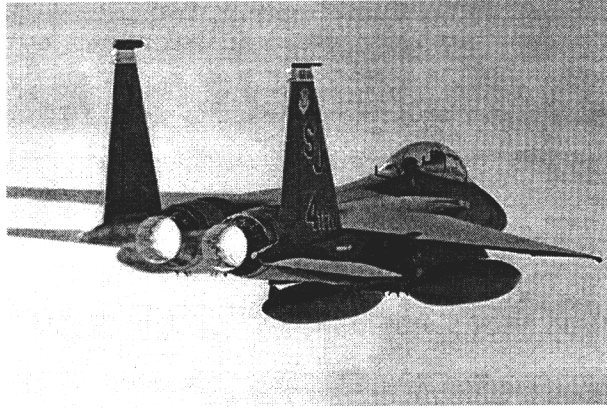

System Components

- Load-bearing structure
- Propulsion
- Power (fuel)
- Payload

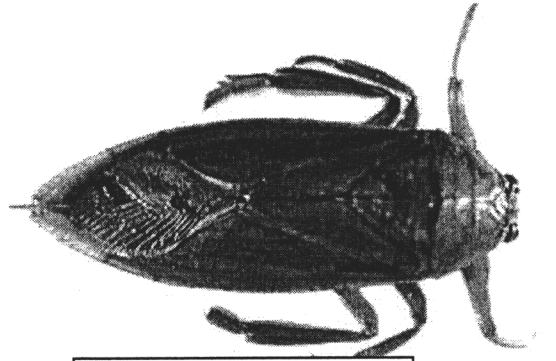

B-7

## Artificial systems

- Functions designed in isolation
- Components have a *single* function

## Nature's systems

- Functions evolved in unison
- Components are *multifunctional*

**Program aims to change the way structures are designed, built and used.**

# Natural Multifunctional Material: An Example



## Cuticle

### A Hetero-nanostructured Material:

(Compositional & Morphological)

**Chitin fiber (3 nm x 180 nm -- like glass fibers)**

**orientation**

**volume fraction**

**Protein matrix**

**pH control**

**water content control**

**modulus control**

**Pore canals**

**connection between epidermal cells and cuticle for communication and repair**

**Interlined holes**

**filled with resilin**

**campaniform sensilla**

**Multi-layered arrangement**

**stiffer outer/softer inner layer**

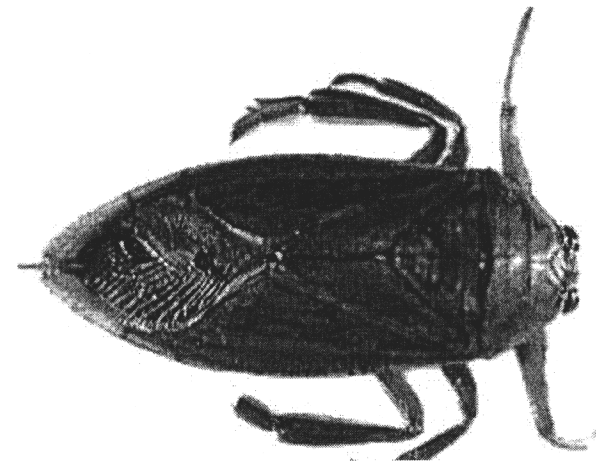

### Design issues solved by Nature!

- Fiber orientation/placement
- Fiber matrix interaction based on chemical control of interfaces
- **Holes/canals distribution without weakening structure**
- **Self-repair, growth**
- **Thermal management**

B-8

# Multifunctional Transformation



B-9

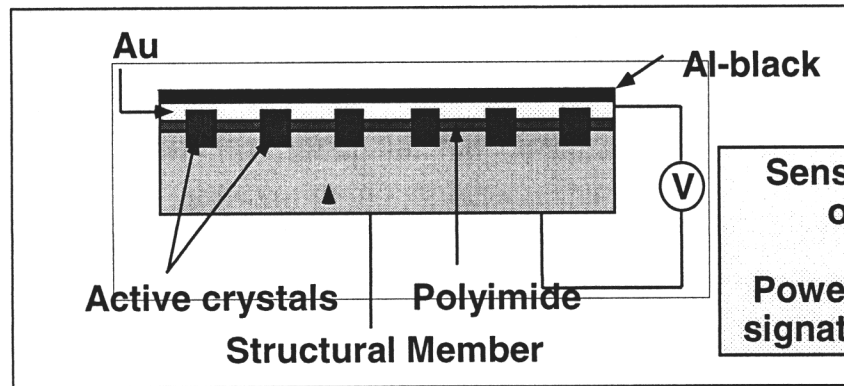
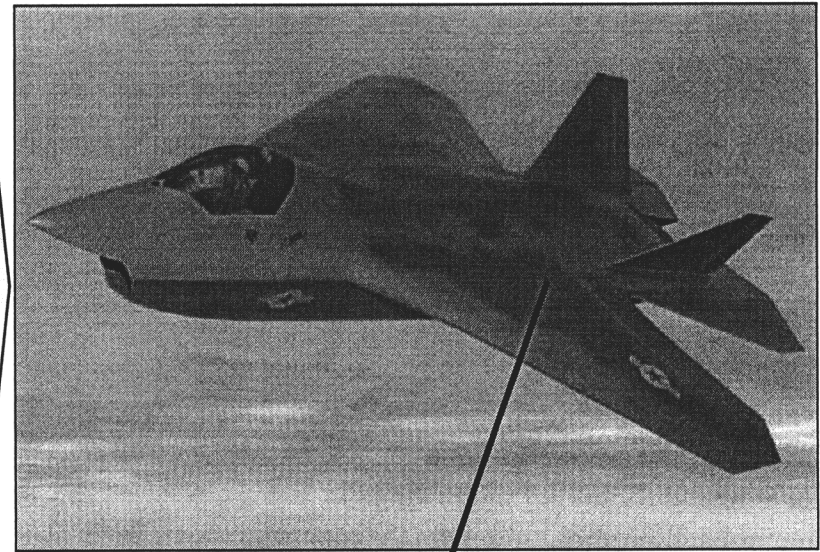
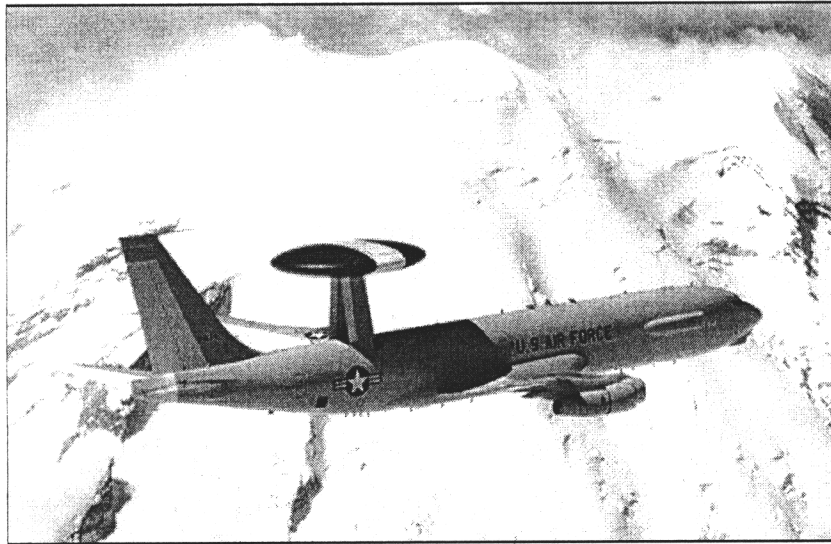

Sensor signal output  
+  
Power input for signature control

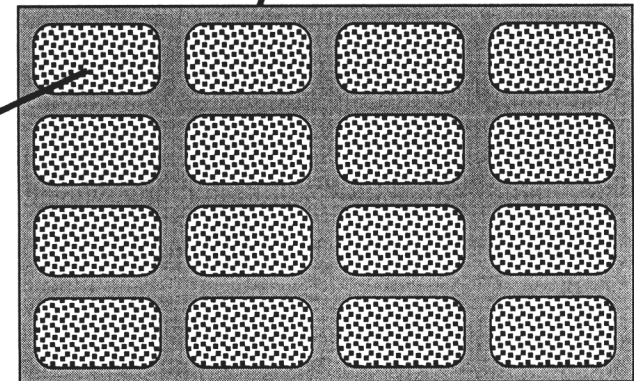

# Specific Objectives



- **To discover the physical bases for the evolution of functions (structural, electromagnetic, thermal, etc).**
- **To understand and be able to select for desired properties at the salient scale.**
- **To establish the capability for reliable prediction of function by models, rules and design tools.**
- **To elucidate the hierarchical organization that gives rise to macroscopically apparent functions**
- **To develop ‘fast’ techniques for optimization for multifunctionality.**
  - **Create and demonstrate application-specific material systems with multiple optimized functions by design.**
  - **Establish approaches and design tools for synthesis, fabrication and use.**
  - **Enable seamless integration with the (existing or evolving) component/subsystem/system design tools**

# SMFM - Challenges



- **How do we optimize functions in a multifunctional material?**
- **How do we capture the features that control the functions of a particular material system?**
  - **Data base population. (Dominance of the extremes).**
  - **Coupled dependence of properties on structural features.**
  - **Evolution of “anomalous” microstructure.**
- **What mathematical techniques are available or need to be developed to enable “multifunctionality” by design?**
  - **Reducing complexity.**
  - **Incorporating variability in design. (Stochastic optimization in design).**

# Synthetic Multifunctional Materials: *Development of SMFM Design Methodologies*

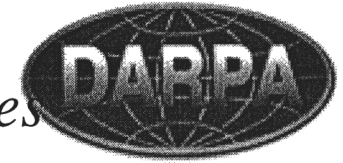

B-12

<u>Materials Characteristics</u>		<u>Research Issues</u>
<b>Mechanical</b>	<b>Stress - Strain</b>	<b>Multi-phase multi-component geometric arrangements</b>
<b>Thermal</b>	<b>Heat Flux - Temp. Gradient</b>	<b>Transition from micro to macro scales</b>
<b>Electric</b>	<b>Flux Density - Field Intensity</b>	<b>Competing linear and nonlinear responses</b>
<b>Magnetic</b>	<b>Flux Density - Field Intensity</b>	<b>Anisotropic behavior</b>
<b>Ballistic</b>	<b>Energy Density-HSR response</b>	<b>Discreet vs. continuous properties</b>
<b>Repair</b>	<b>????</b>	

**Major Challenge: Integration of diverse features/requirements into useful materials and design tools**

# SMFM Program Elements

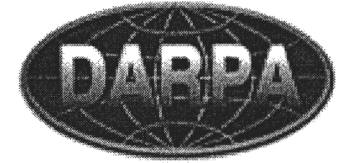

## 1. Power Structures

- a. Power Fibers
- b. Power laminates
- c. Structure-integrated fuel cells
- d. Charge/hydrogen storage structures

## 2. Actuating and sensing structures

## 3. Survivable structures

## 4. Autogenous (Self healing) structures

## 5. Autophagous (Self consuming) structures

## 6. Thermal control structures – transition

**Models, Rules  
and Tools**

**Specific  
Demonstrations**

# SMFM Power Structures



- Power Structures
- Sens./Comm. Structures
- Self Actuating Structures
- Self healing/Decon.
- Survivable Structures
- Autophagous Structures
- Models, Rules & Tools

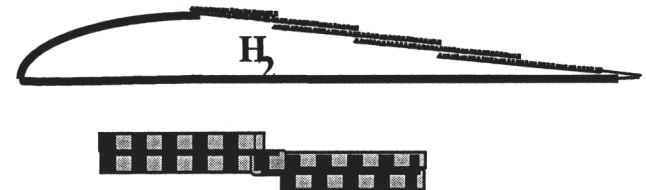
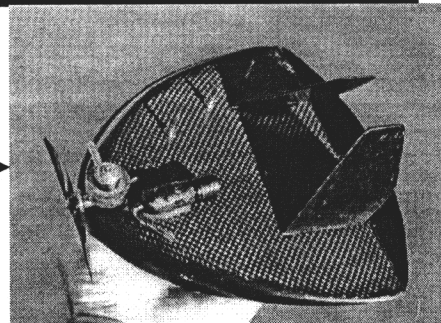

Metal element serving as wing structure, antenna and current collector

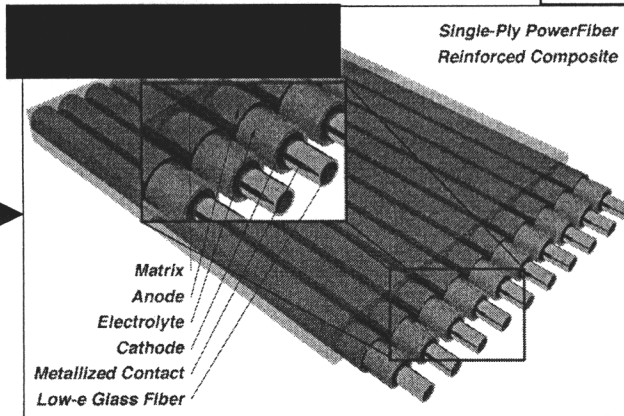

Reinforcing fiber serving as structure and battery

- Localized power source(s)
- Integral antennas and actuators
- Distributed power for damage tolerance and low transmission loss

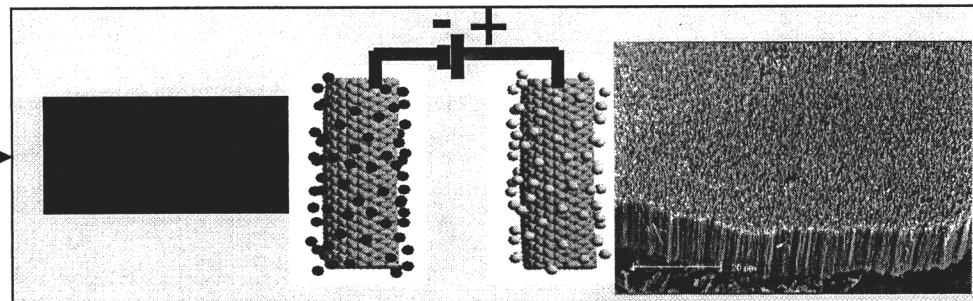

CNT serving as structure, actuator, and supercapacitor

B-14

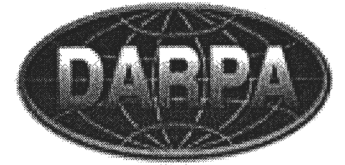

# SMFM Power Fibers

B-15

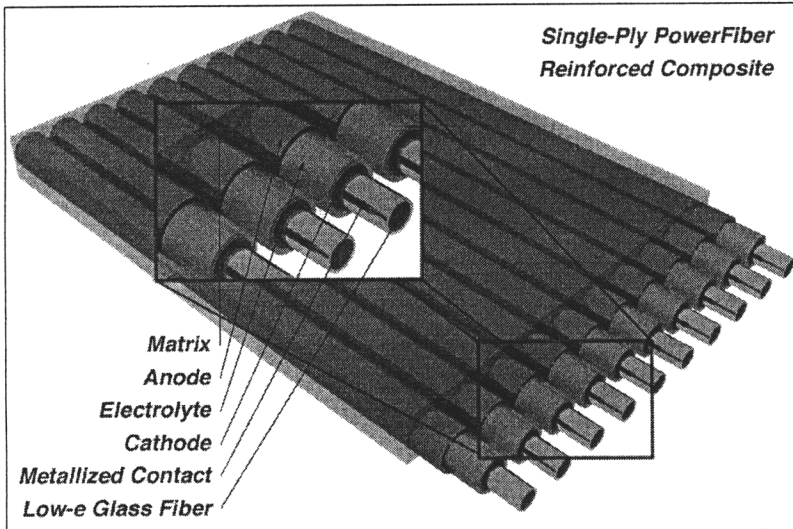

**Integrate power with structure**

**Robust energy source**

**Non parasitic**

**Transparent to user**

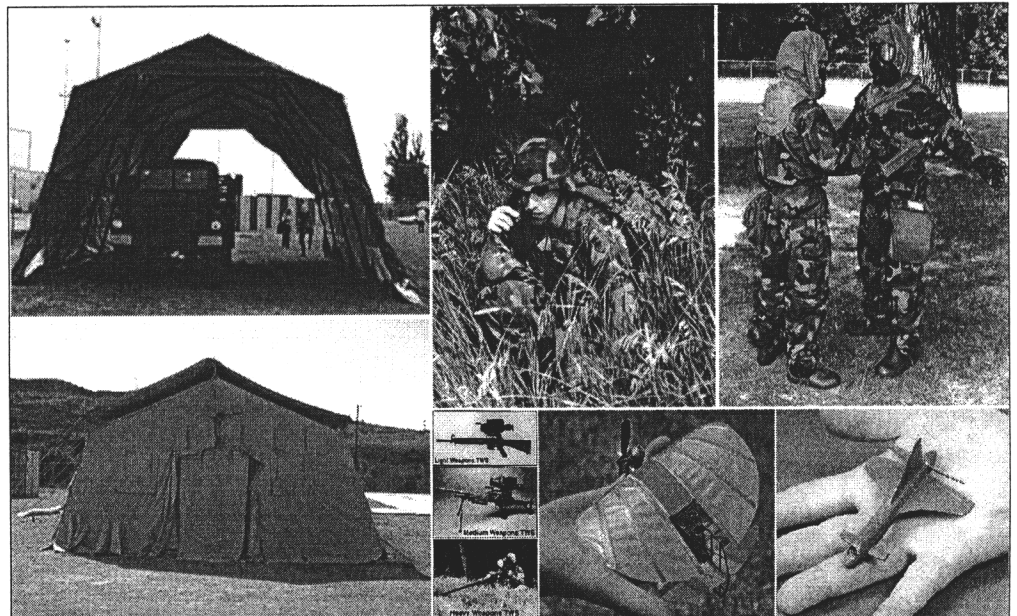
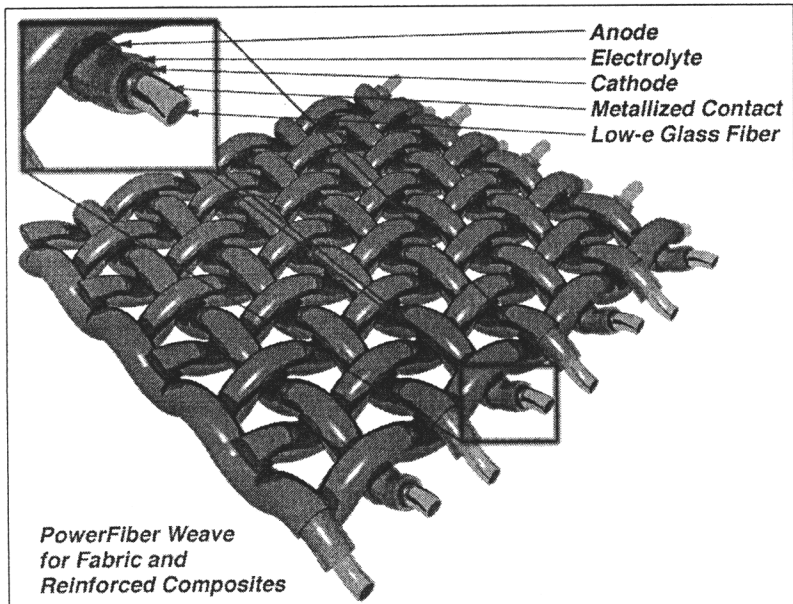



# SMFM Power Fibers

- Production of novel woven zylon/lithium ion battery fabrics with dual functionalities.
- Development of computational models and tools for design of woven fabrics and structures.

B-16

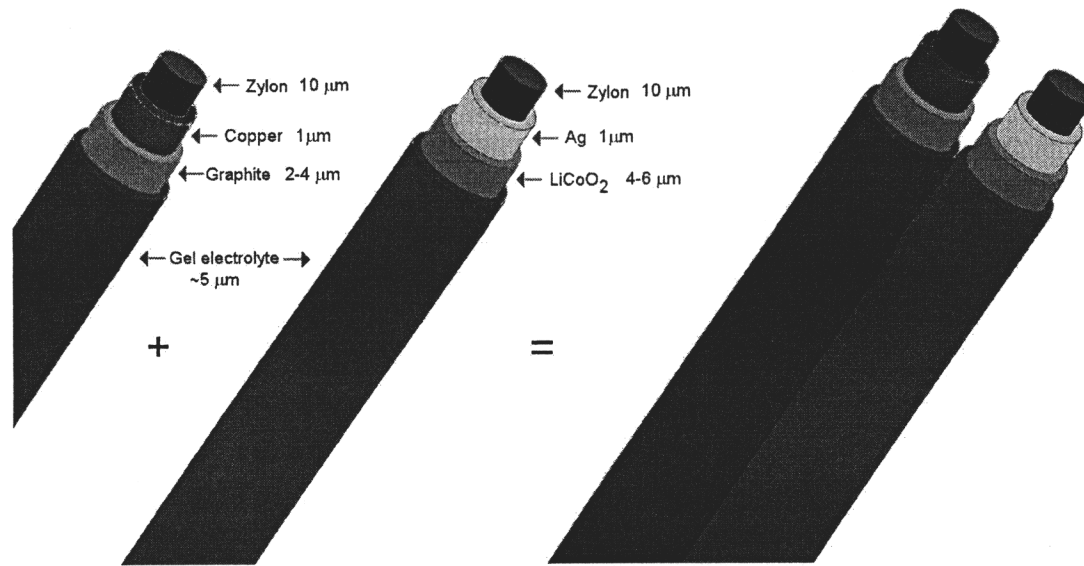

Separate Anode and Cathode Filament Battery

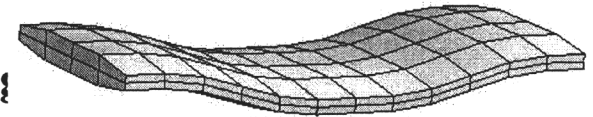

Detailed Yarn Model

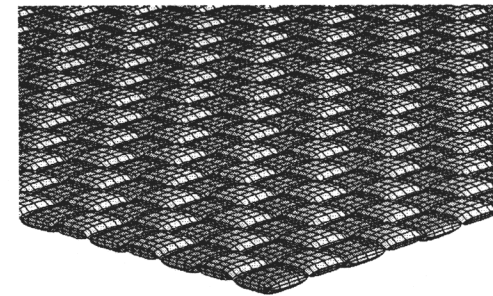

Detailed Woven Fabric Model

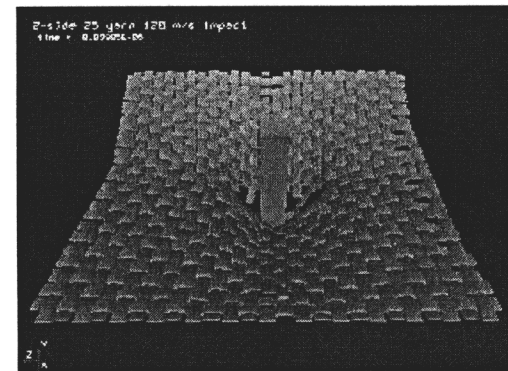

Simulation of Fragment Impact

# Multifunctional Laminate Material Systems



B-17

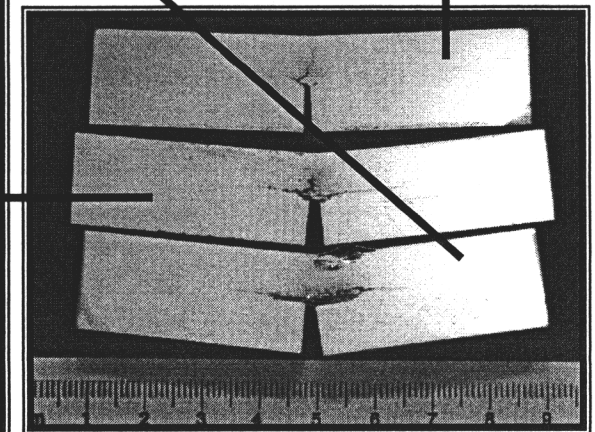
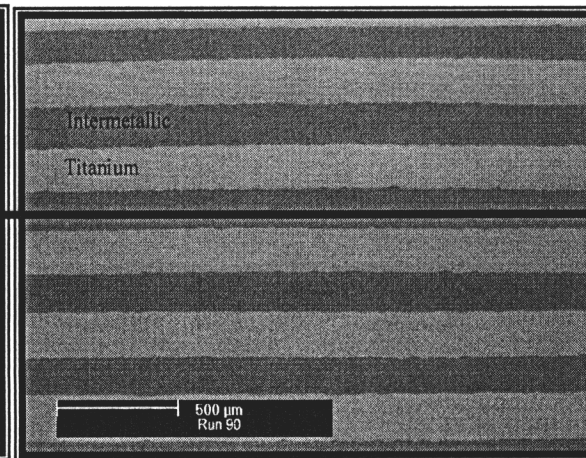
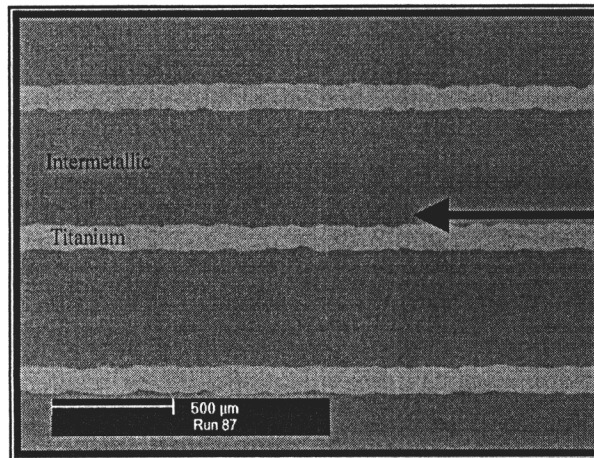
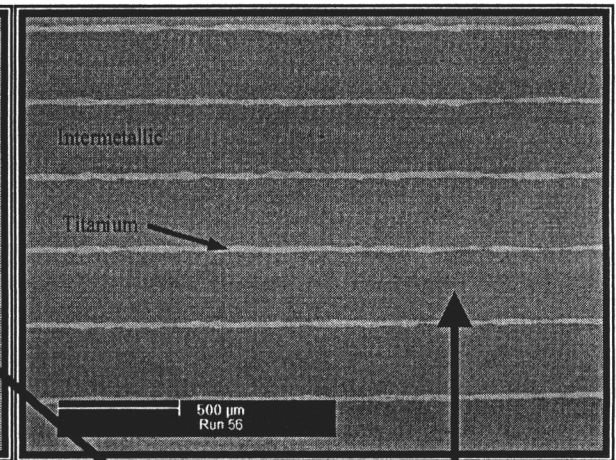
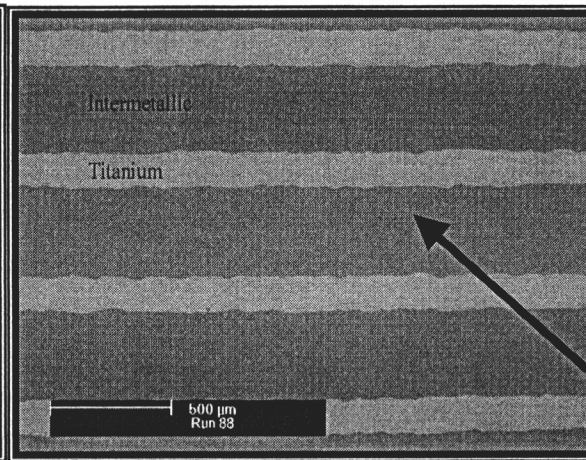
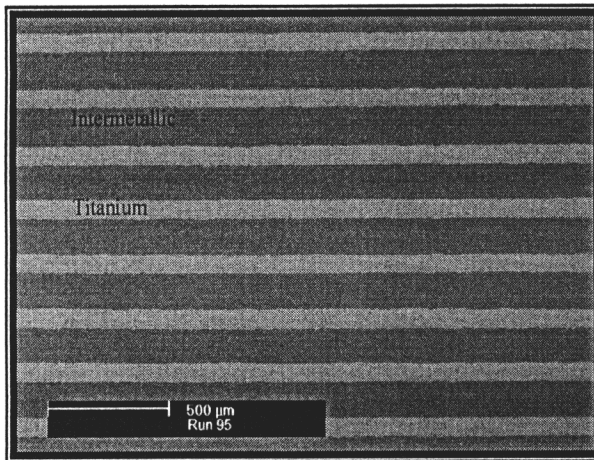

UCSD

# SMFM: Tunable Structures

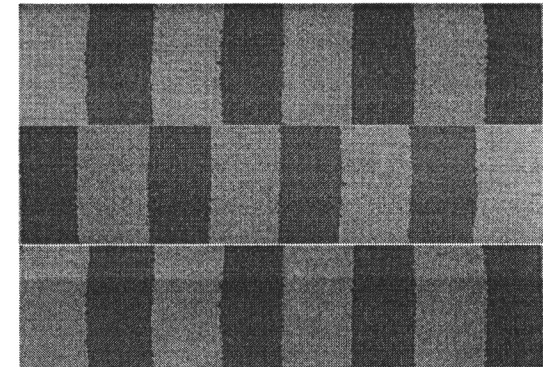
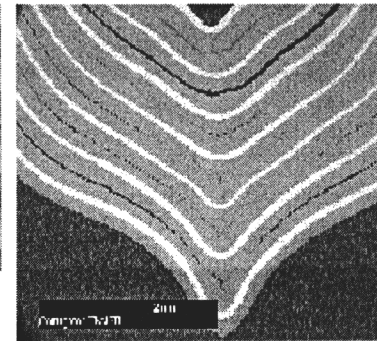
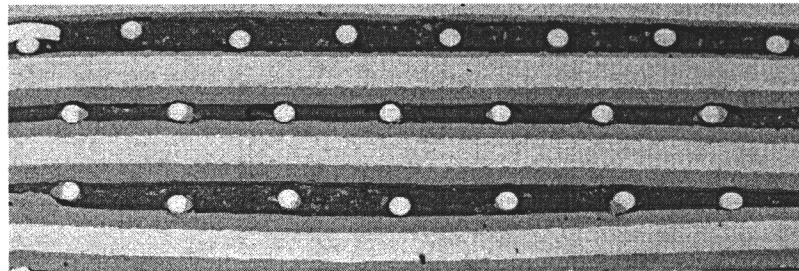
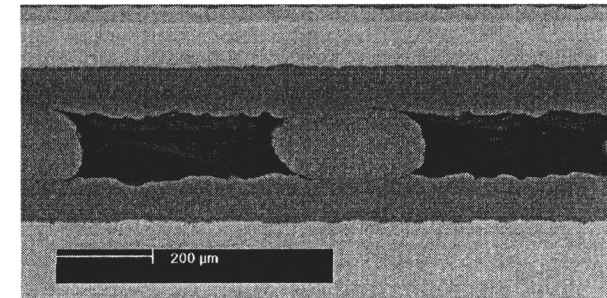
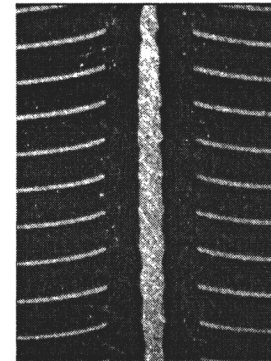
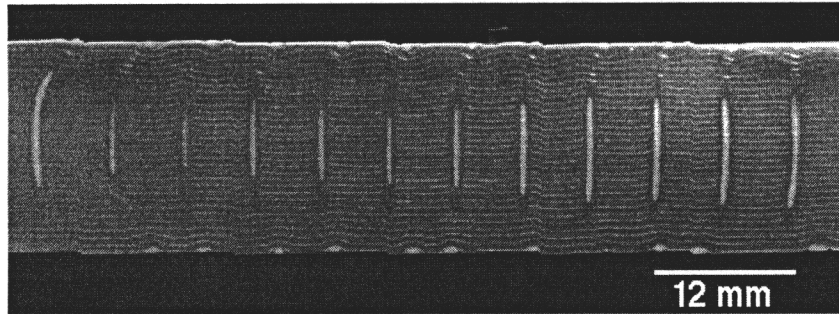

B-18

**Morphology design and control can provide:**

- **Strength and damage tolerance**
- **Integrated antennas, sensors and actuators**
- **Engineered dampening response**
- **Engineered electromagnetic properties**
- **Chemical sensing capability**

**UCSD**

# SMFM: Integrated Fractal Antennas

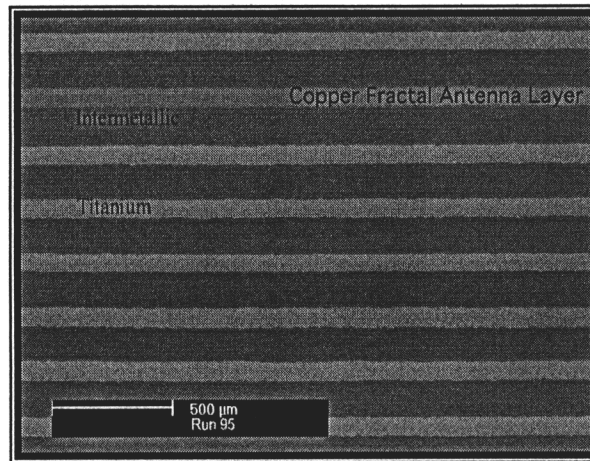
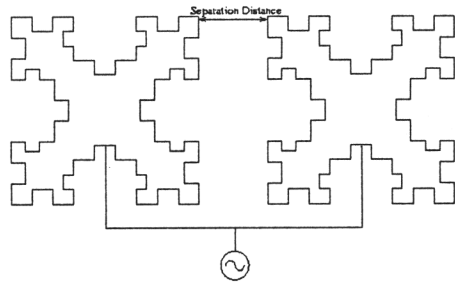
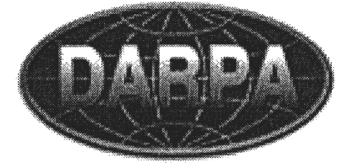

Sierconn0 9.4 GHz

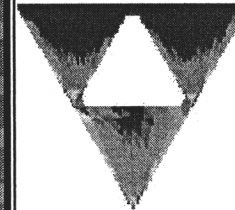

Sierconn0 23.8 GHz

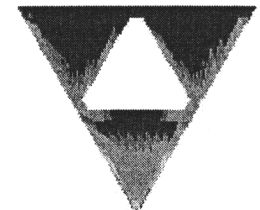

Sierconn1 5GHz

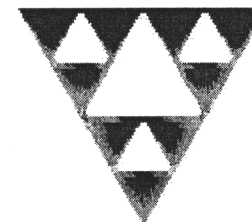

Sierconn1 23.8GHz

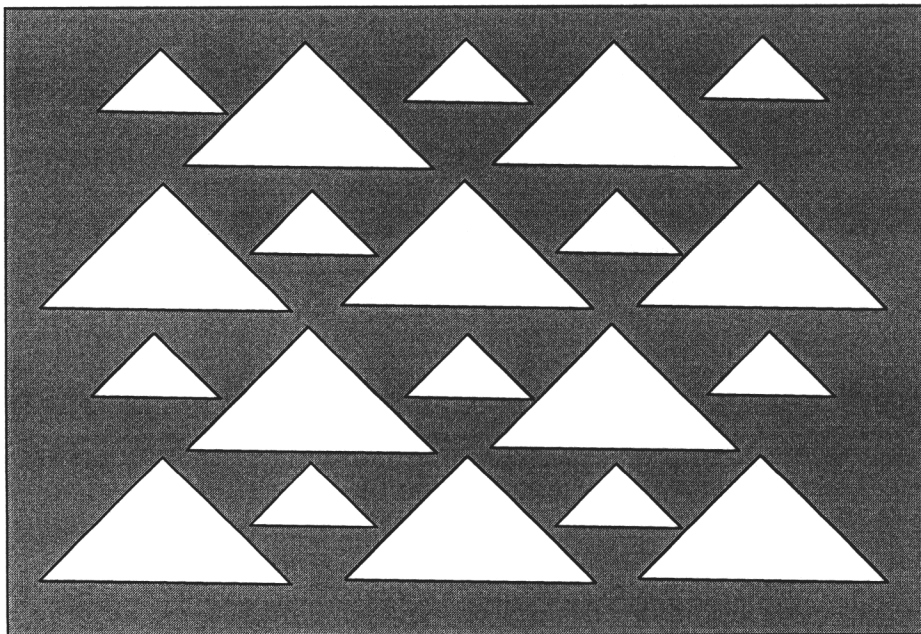
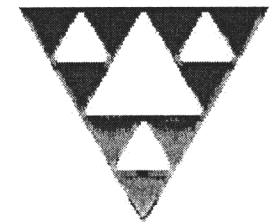

B-19



# SMFM: Structure as a Sensor

- Structure with integrated “million eyes” concept. Ability to look continuously in all directions with no surface mounted imaging
- Structure with “chemical environment” sensors

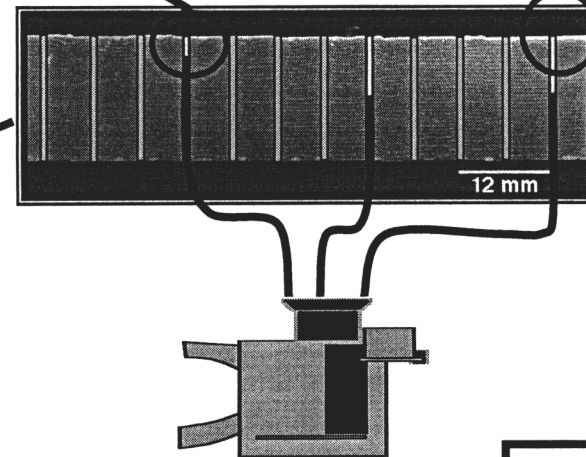
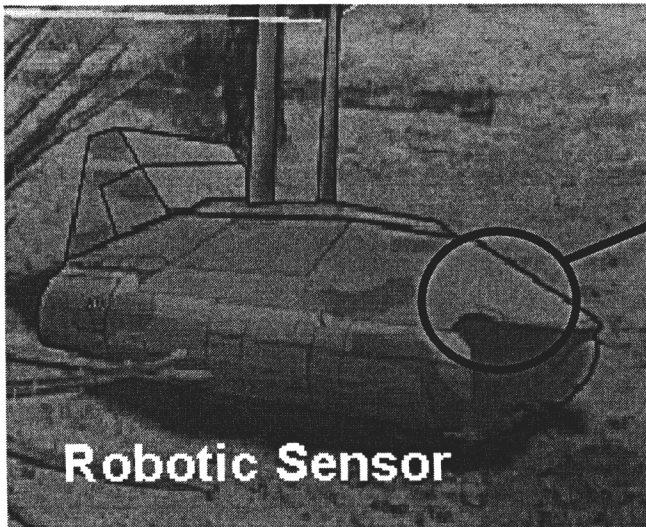
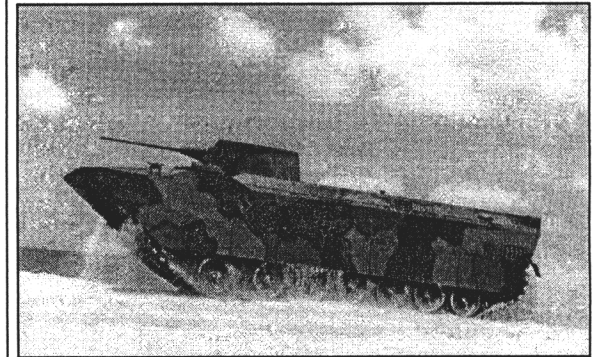
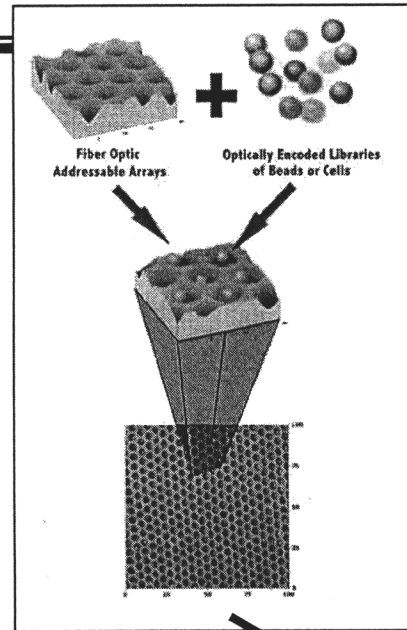

UCSD

B-20

# Left Handed Materials

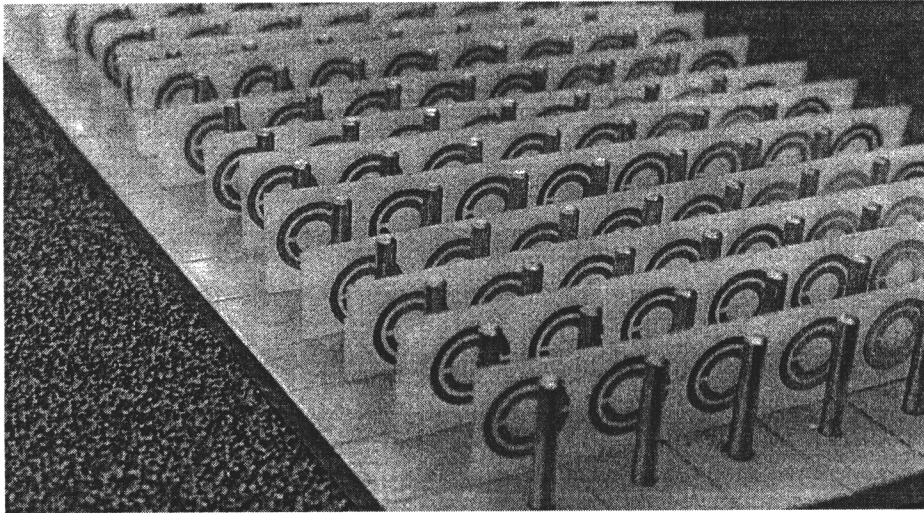

- Engineered chemical and morphological control allows for controlled properties
- Theoretically predicted
- Experimentally verified (ref: Schultz et.al. Science, 2000)

B-21

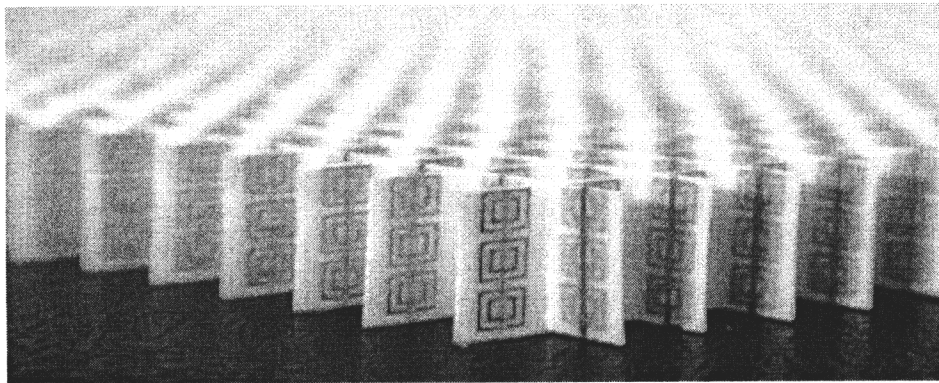

UCSD

# SMFM Self Adaptive Structures



## Tensegrity Structures

- Advanced material systems concepts based on compressive elements stabilized by tensile tendons (TENSEGRITY)
- Spatial and stress distributions define behavior of structure
- Passive or active response possible. Members serve as actuators, sensors, and structural support

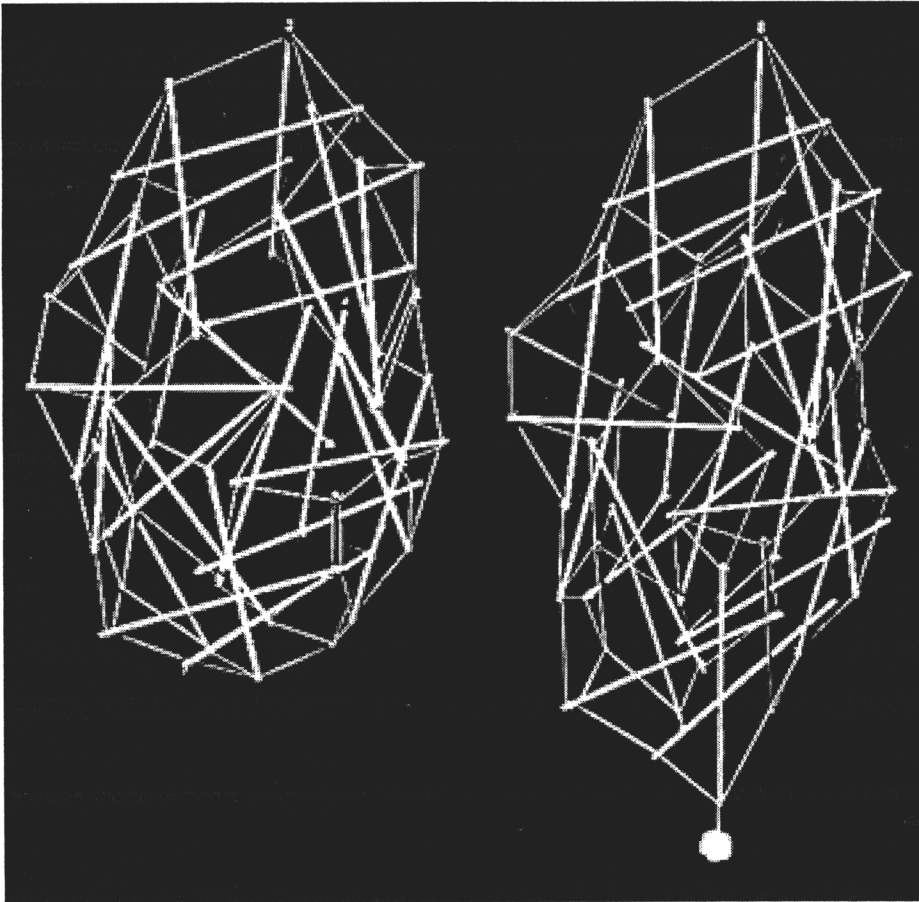

B-22

# SMFM Self Adaptive Structures

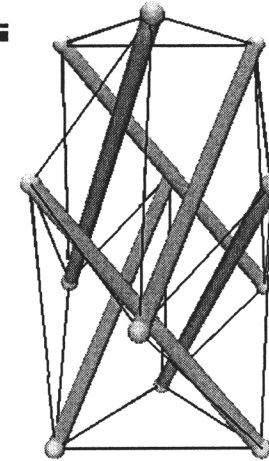

B-23

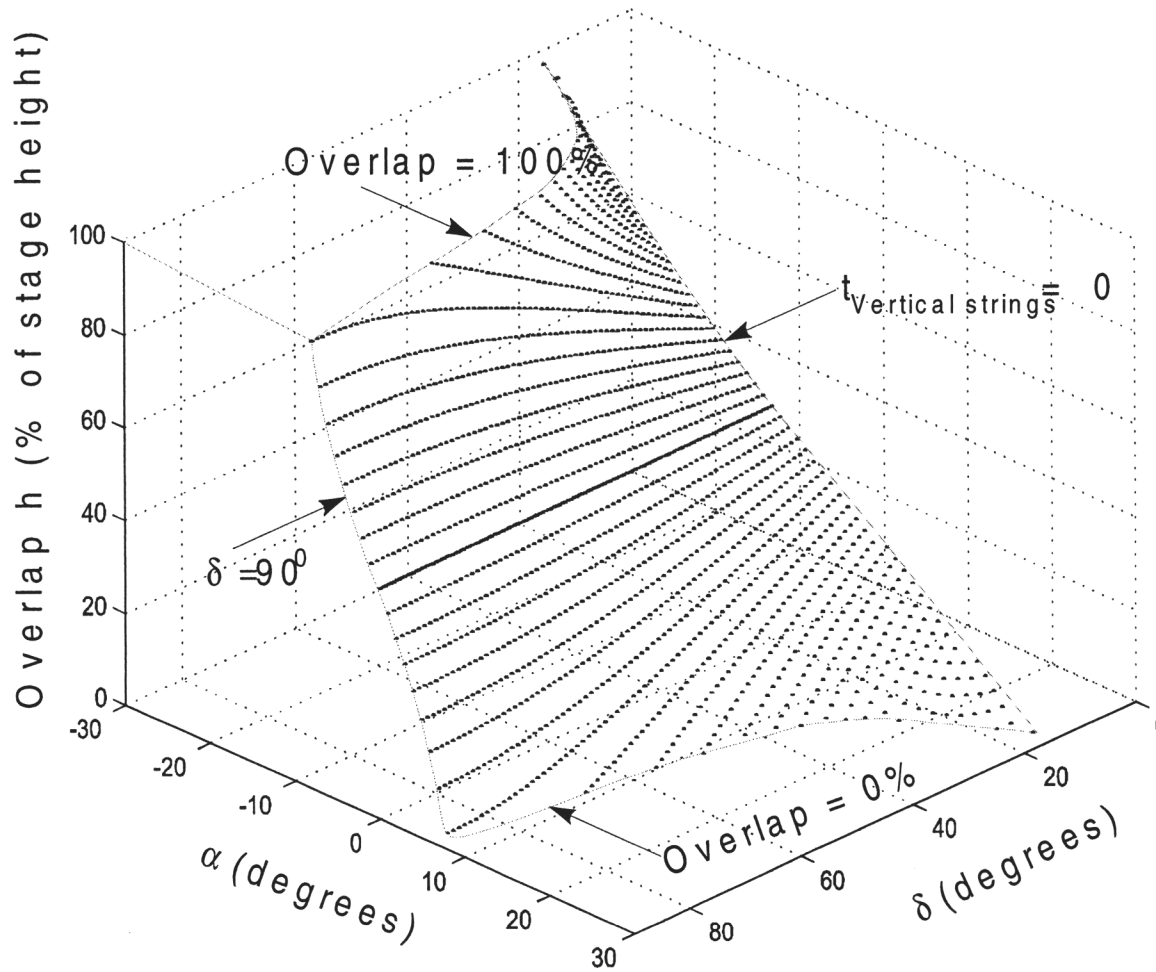

- No joints
- No load reversals
- No member bending
- No potential energy change over a large range of states. (In equilibrium over a range of shapes)
- No CPU necessary for control—locally adaptive

# SMFM: Self Healing Strategies



## Natures Template

- Detect “not normal” by distributed sensors and autonomous roving monitors
- Two stage processes: “temporary patch” then “remodel for permanent repair”
- Dynamic system (not equilibrium)
  - Materials (proteins, cells) that can be formed/removed under dynamic state
  - “Futile cycle” strategy: repair/healing is an extension of remodeling/maintenance
  - Shed, re-grow, ablate
- Fluids for mass transport
- ‘Smart’, autonomous and mobile particles/systems
- ‘Smart’ membranes

B-24

## Synthetic ‘Toolbox’

- Surface tension, energy and activity
- Osmotic pressure
- Switchable systems (liquid crystals)
- Damage-activated reactions
- Heat generation
- Self-assembly
- Self re-aligning structures
- Structures that shed their surface
- Electrostatically/magnetically/optically actuated/ guided systems
- Negative Poisson ratio systems

Harvard /Princeton

# Self Healing by Electrohydrodynamic Coagulation of Particles

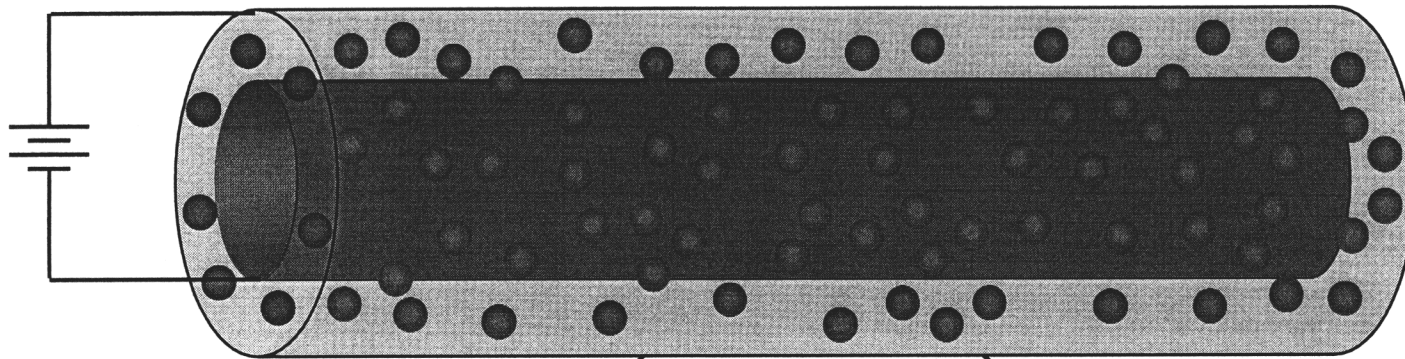

8-25

Sub-Critical  
Current Density

2D Particle "Gas"

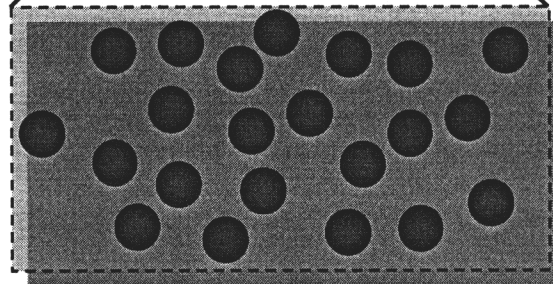

Surface Defect →  
Increased Current Density

Defect Nucleates  
Assembly

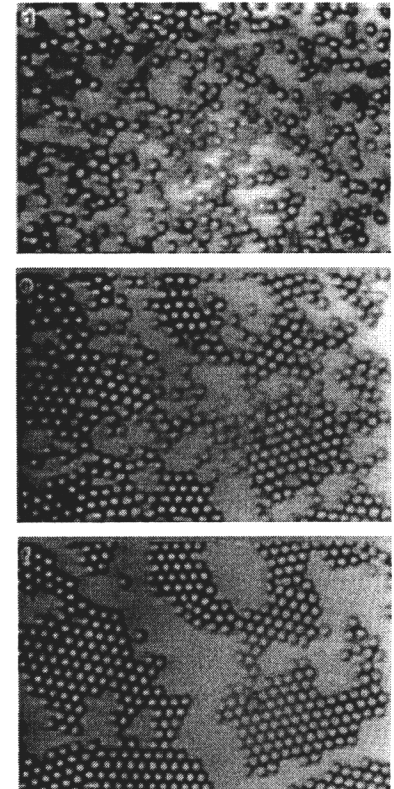
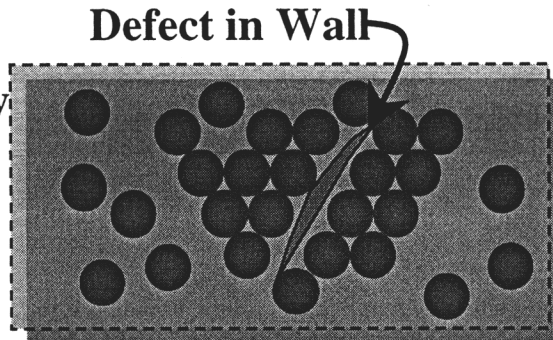

# Light-modulated Electrophoretic Self Healing

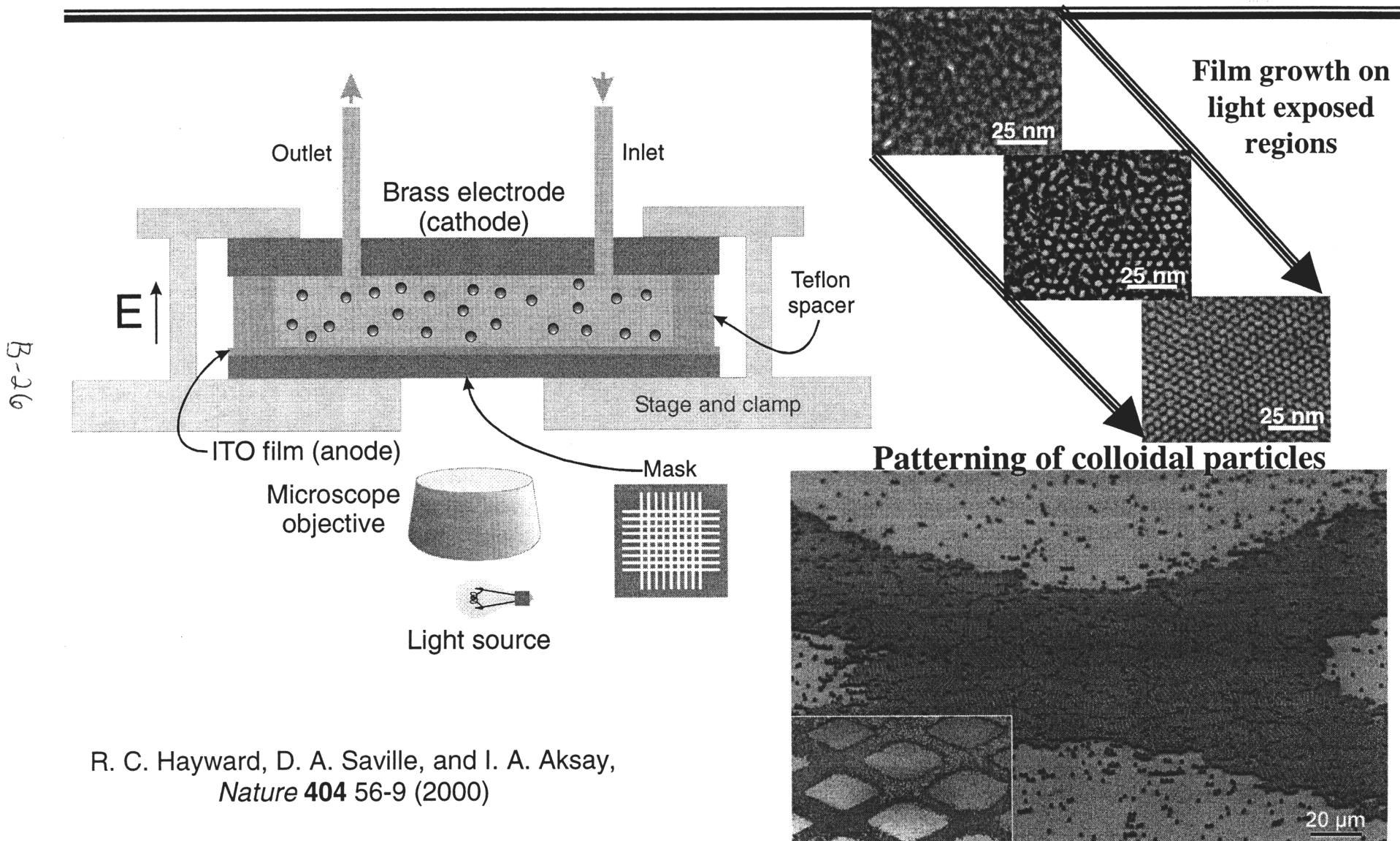

R. C. Hayward, D. A. Saville, and I. A. Aksay,  
*Nature* **404** 56-9 (2000)

# SMFM: Self Repair Systems



B-27

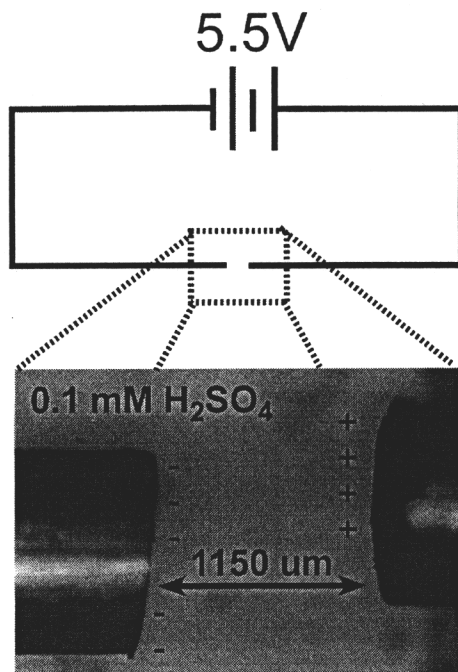

General strategy:

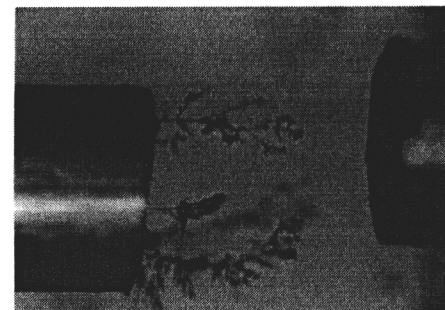
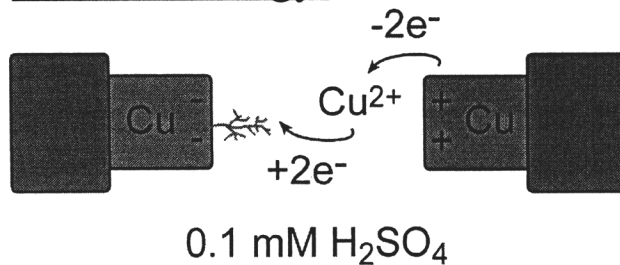

25 sec after applying potential

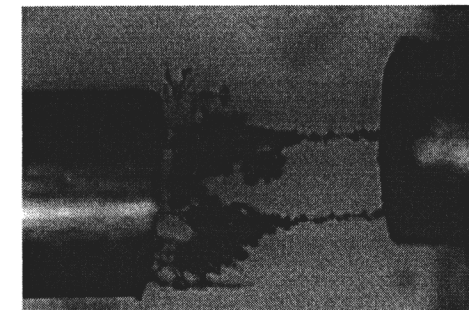

60 sec after applying potential

- Electric field directs growth of wire toward the anodic electrode
- Growth slows and finally stops as wires make contact and eliminate the potential difference
- No external copper source necessary
- Should wires break, the potential difference is reestablished and new growth is initiated

Bradley, J.-C., *et. al. Nature* **389**, 268.



# Self Consuming Structures

- **Functions of space system structures**
  - withstand direct launch loads, no function on orbit
  - provide shear strength, radiation shielding, some function on orbit
- **Parts of non-functional structure on orbit may be consumed to produce useful thrust**
  - orbital mobility, especially high thrust/impulse operations
  - end-of-life operations
- **Using excess structural material as propellant will**
  - reduce spacecraft size and weight; less onboard propellant and less structure to contain propellant
  - increase orbital lifetime if structure consumed as additional propellant

B-28

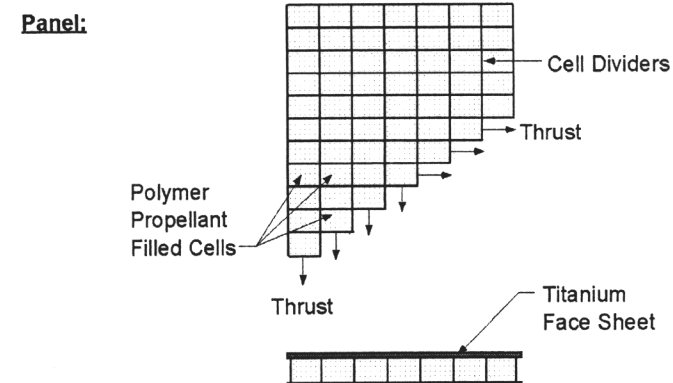
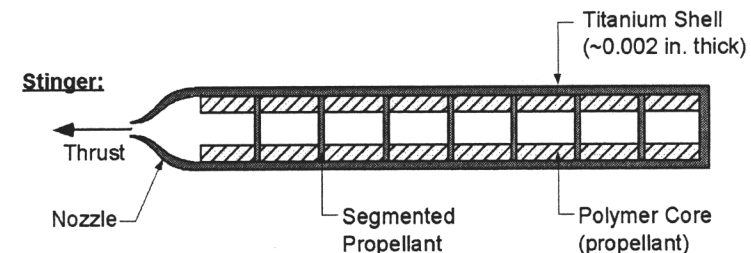
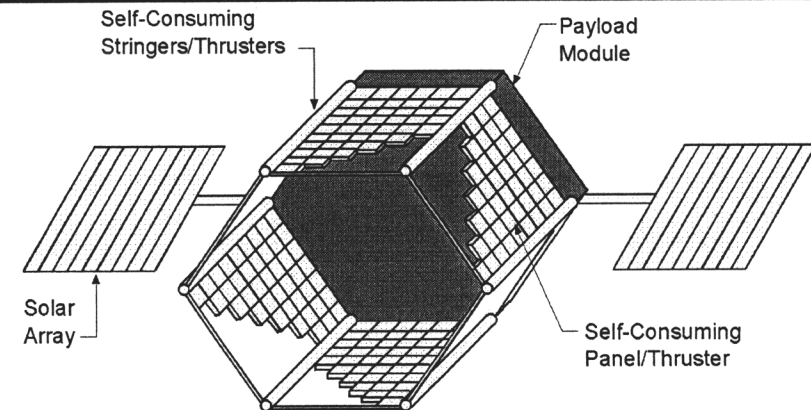

# SMFM: Thermal Control Structures



B-29

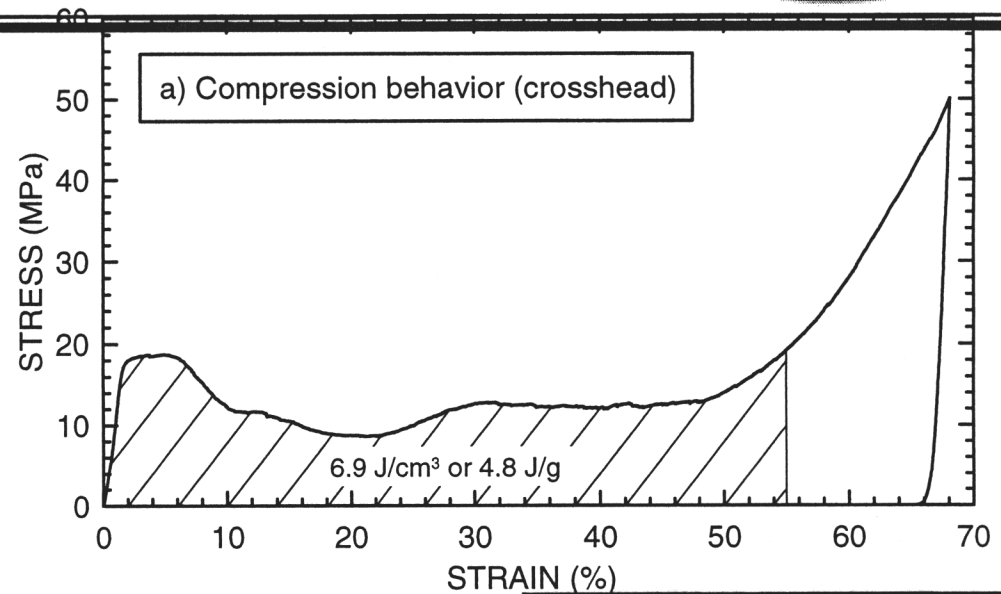
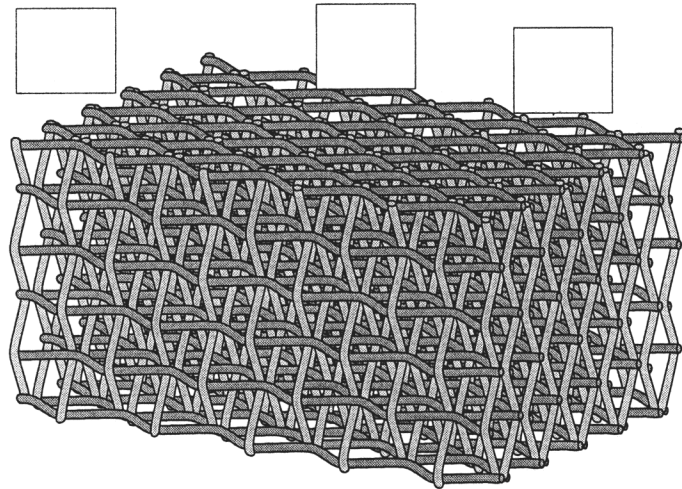

- Very high structural efficiency
- Structures conducive to thermal management
- Integrated antennas and actuators
- Engineered damage response
- Low cost conformal structures

10mm

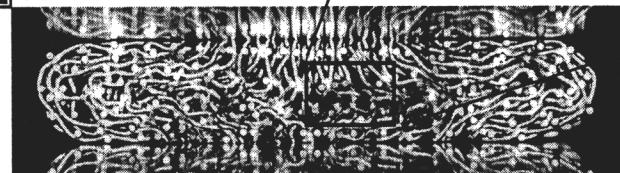
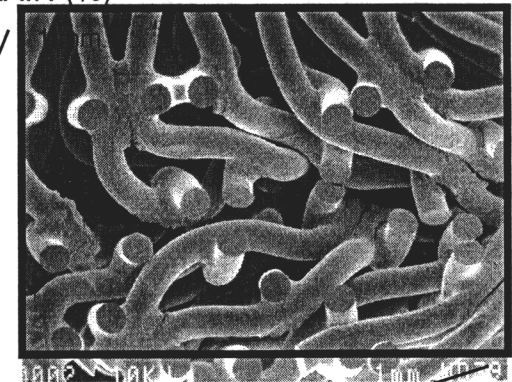

# SMFM: Thermal Control Structures Transition



## REQUIREMENT

AEW/EW electronics require 3X heat dissipation

## SMFM SOLUTION

- Advanced foam metal heat exchangers improve efficiency by a factor of 10X.
- Porous metal heat exchangers:
  - 30% Lighter
  - 40% Smaller
  - 10% Less expensive
- New avionics suite with conformal racks and cards.

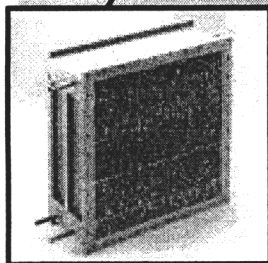
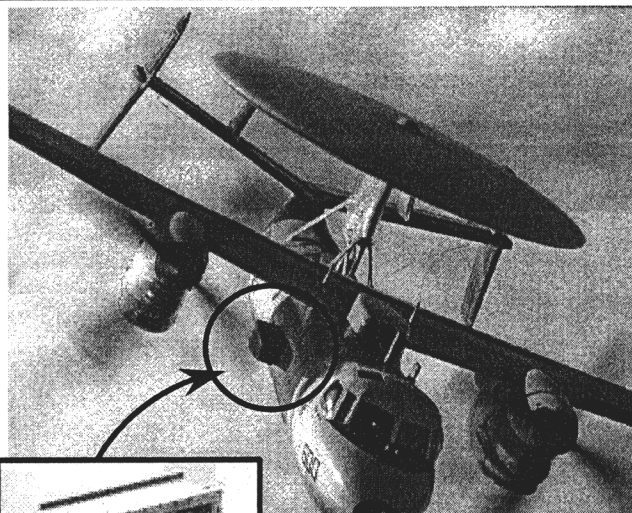

Foam Metal Heat Exchanger



Integrated Avionics Rack (internal)

B-30

**Program:** Design, Fab. & Test of Heat Exchanger.  
Conceptual Design for EA-6B ICAP-3

**Sponsors:** DARPA, Navy and NG (E-2C Program).

# SMFM: Thermal Control Structures



B-31

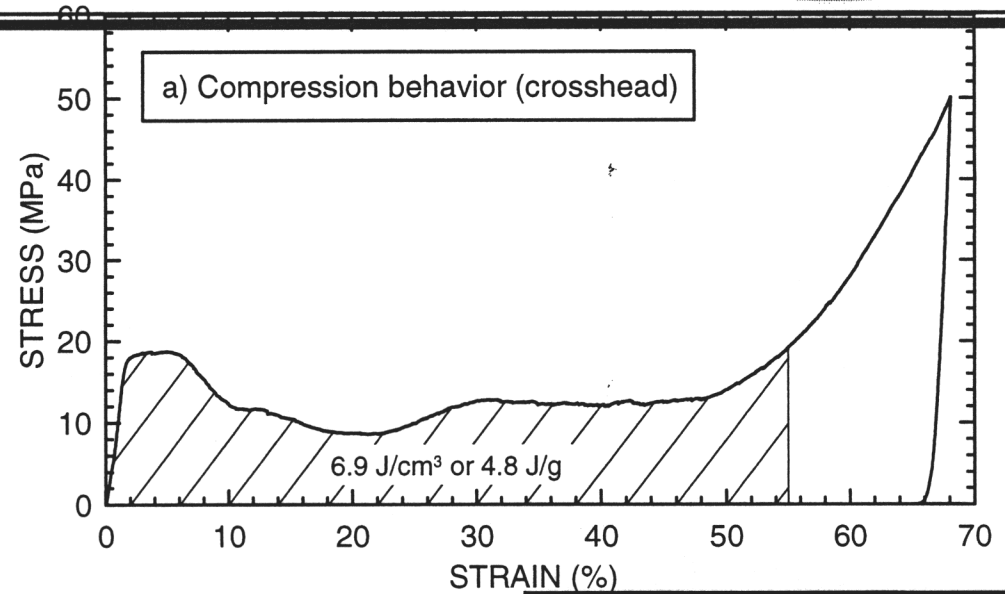
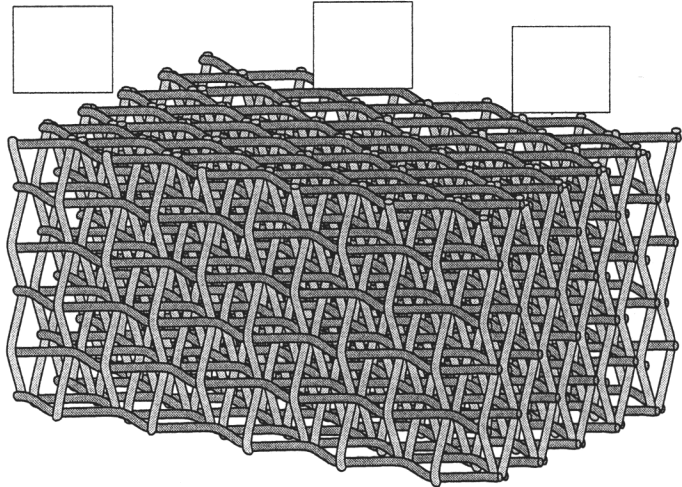

- Very high structural efficiency
- Structures conducive to thermal management
- Integrated antennas and actuators
- Engineered damage response
- Low cost conformal structures

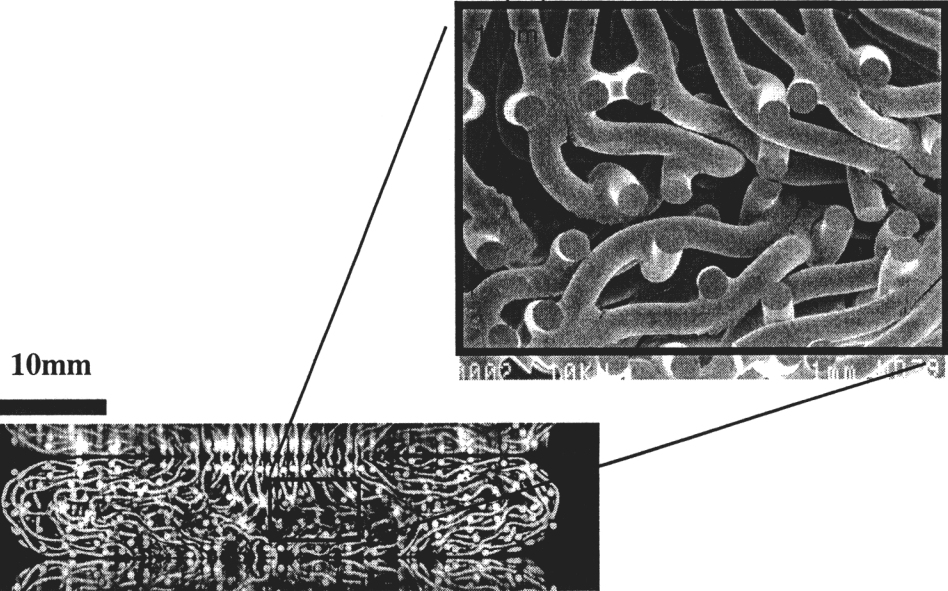

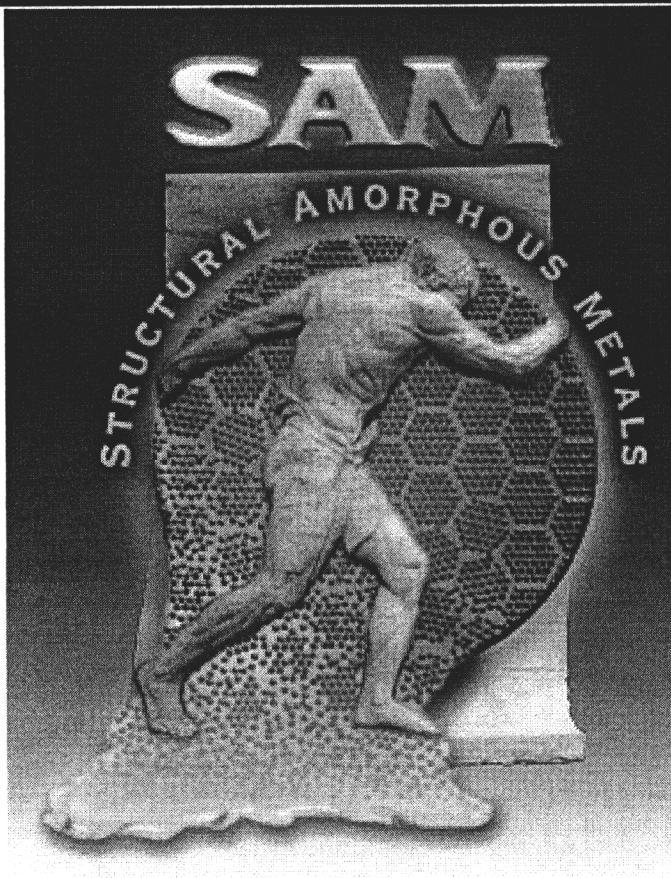

# Structural Amorphous Metals

B-32

## Compelling Opportunity



---

### Structural Amorphous Metals

- **A new class of materials with a radical combination of properties**
- **There are unique, compelling and enabling applications in several key DoD areas (e.g. ship hulls, aircraft structures, penetrators, etc.)**
- **DARPA aims to develop the science and technology of this field, and demonstrate its utility in example challenge problems**

# Amorphous Metals are Fundamentally Structurally Amorphous Metals Different to Conventional Metals

---



## *Crystalline (Normal) Metals*

- *Long-range order*
- *Grain boundaries*

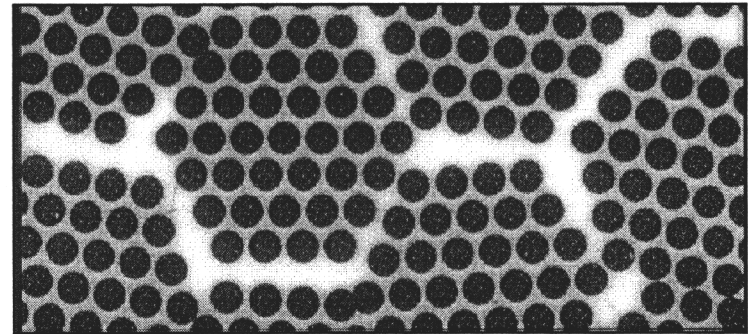

## *Amorphous Metals*

- *NO long-range order*
- *NO grain boundaries*

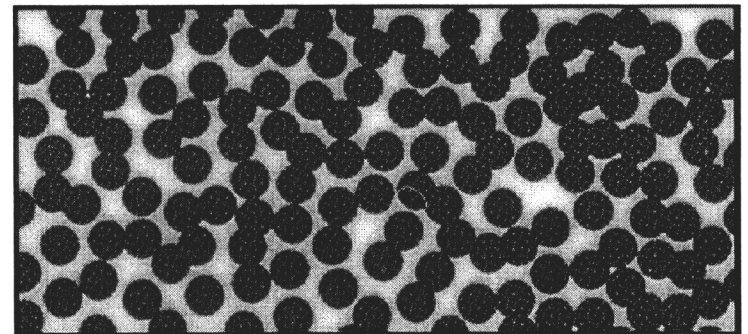

- **Amorphous materials exhibit unique properties**

# Atomic Arrangement in Crystalline and Amorphous Metals



- **Micrograph shows:**
  - **interface between amorphous and crystalline metal**
  - **atomic planes of crystalline metal**
  - **random arrangement of amorphous material**
  - **diffraction information**

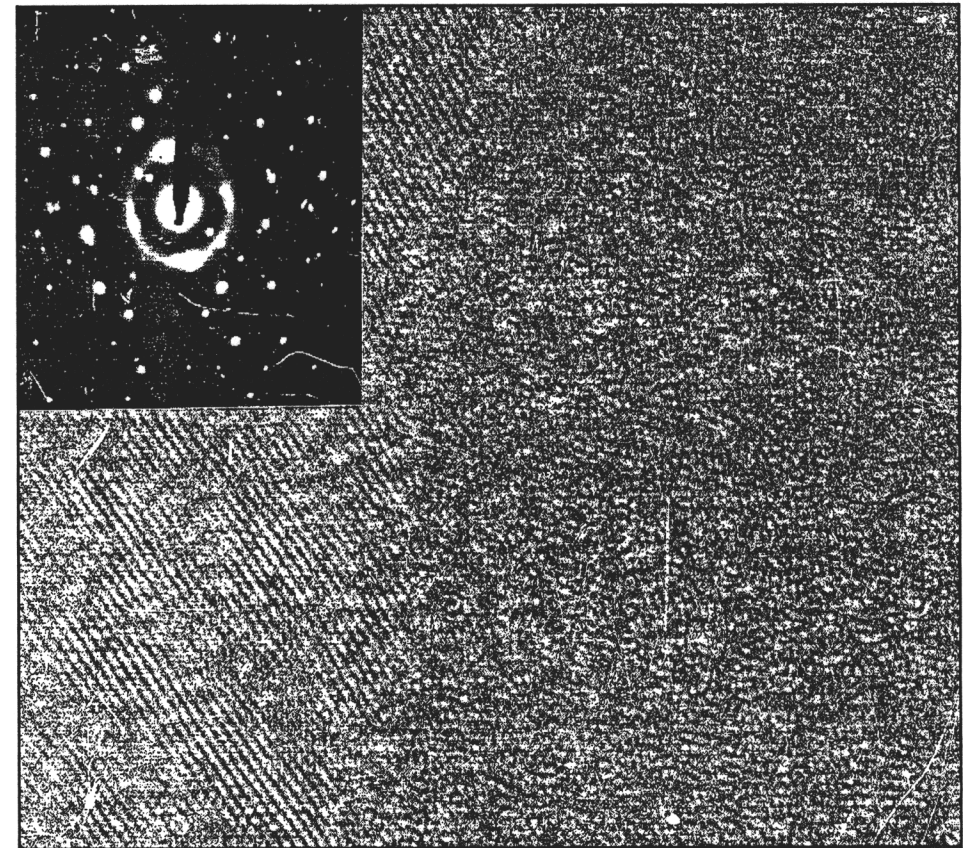

← Crystalline → ← Amorphous →

# Structural Amorphous Metals



## Polycrystalline

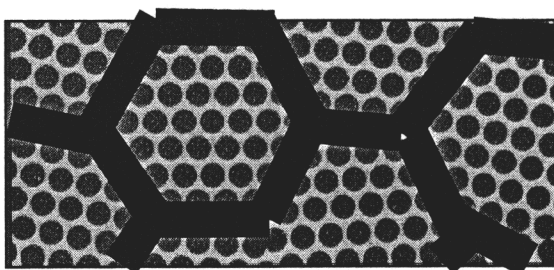
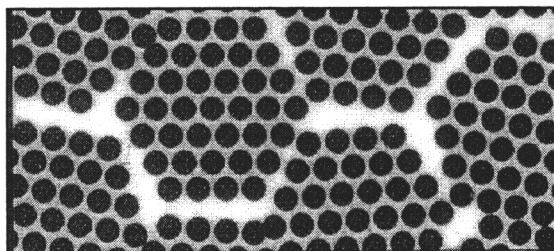

- Intersections of grains (grain boundaries) can be considered as “amorphous”.
- Changes in grain size change the volume fraction of amorphous content

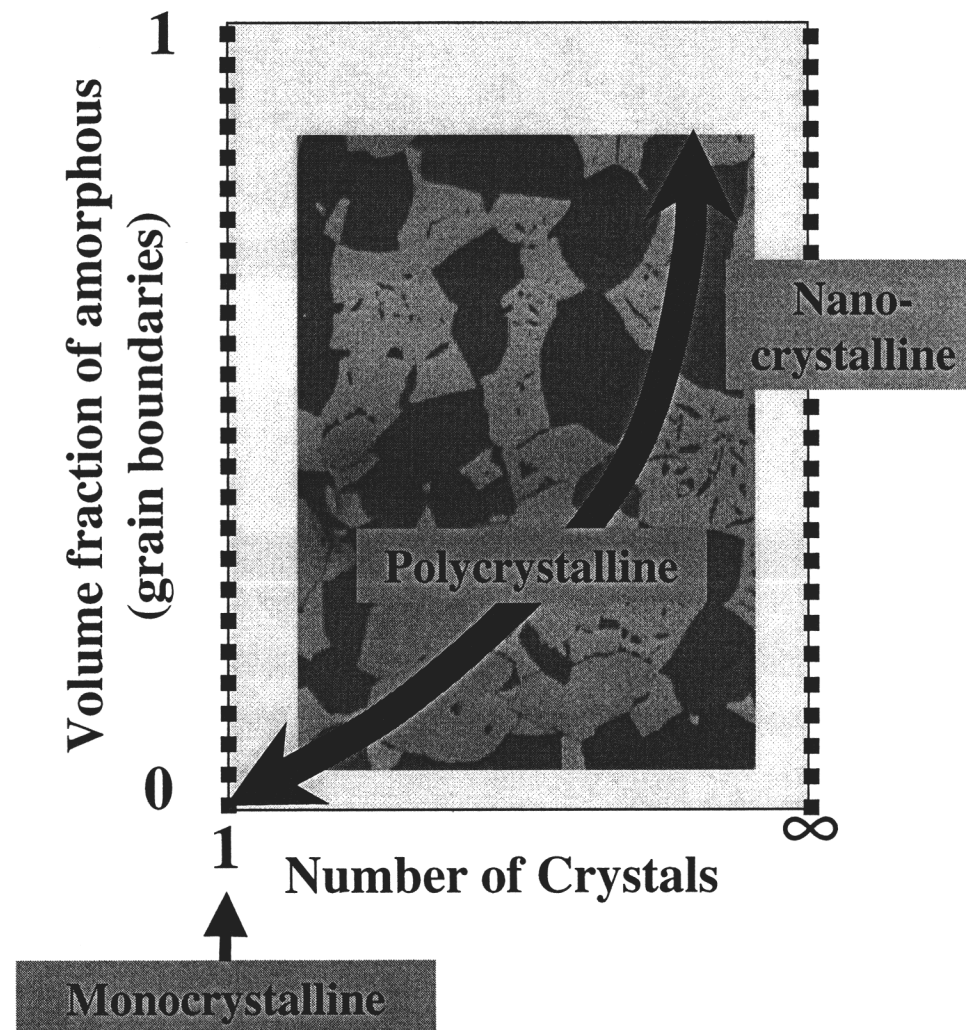

13-36

# Amorphous Metals Are Truly New

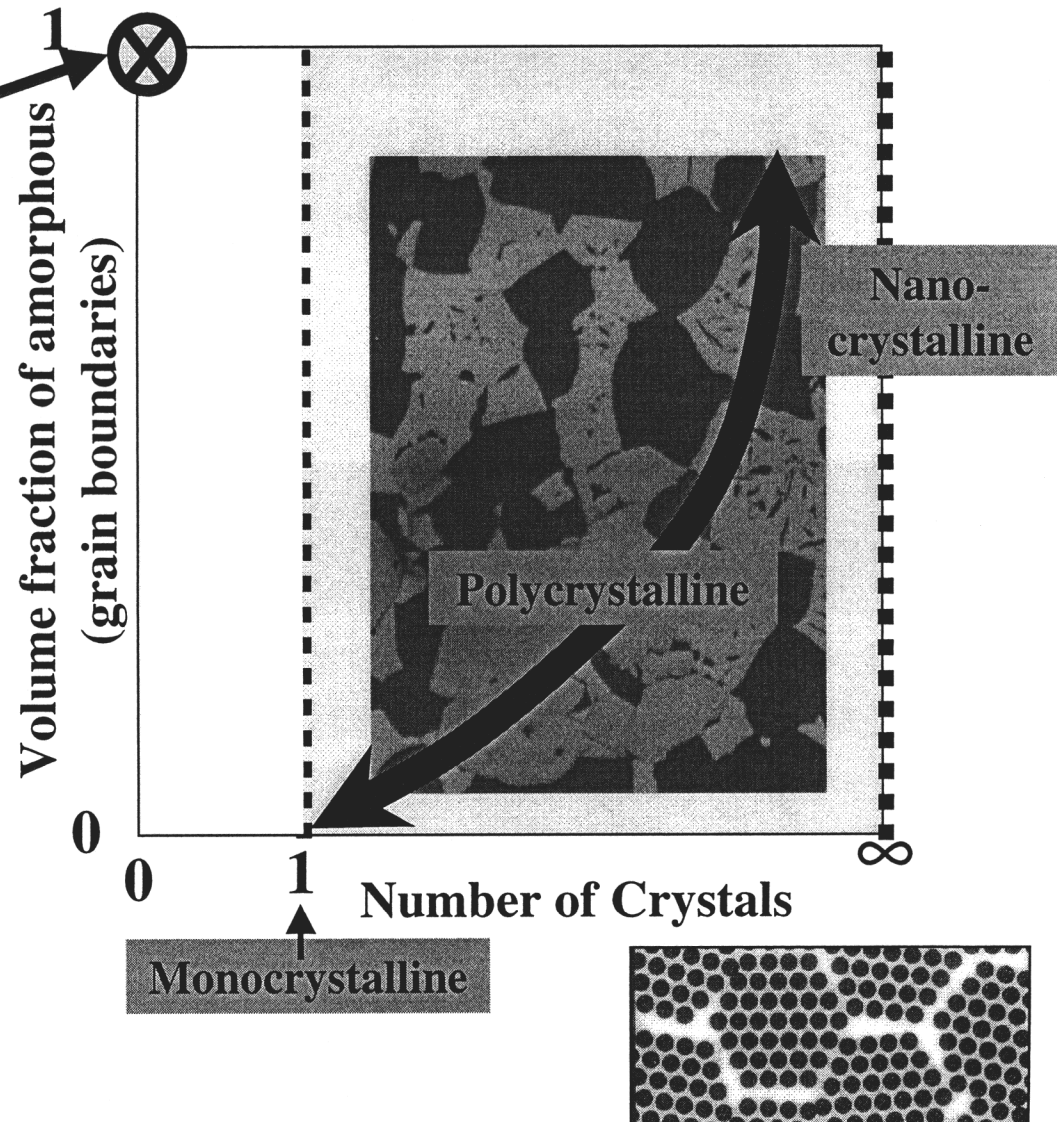

- Amorphous Metals are NOT confined by limitations of crystalline materials
- Such an opportunity has NOT previously existed for structural materials.

13-37

# Transformations of SAM to Crystalline Offer Unprecedented Materials Design Freedom



- Short-range order
- NO grain boundaries

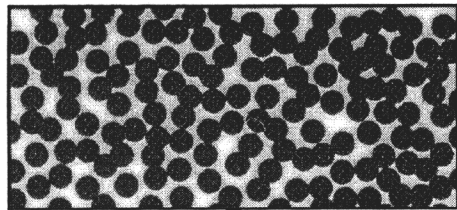

Transition path could be of **CRITICAL** importance

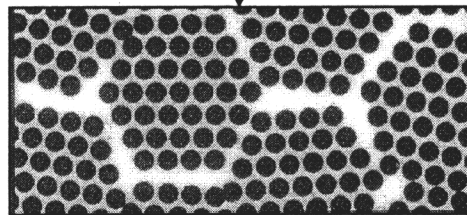

- Long-range order
- Grain boundaries

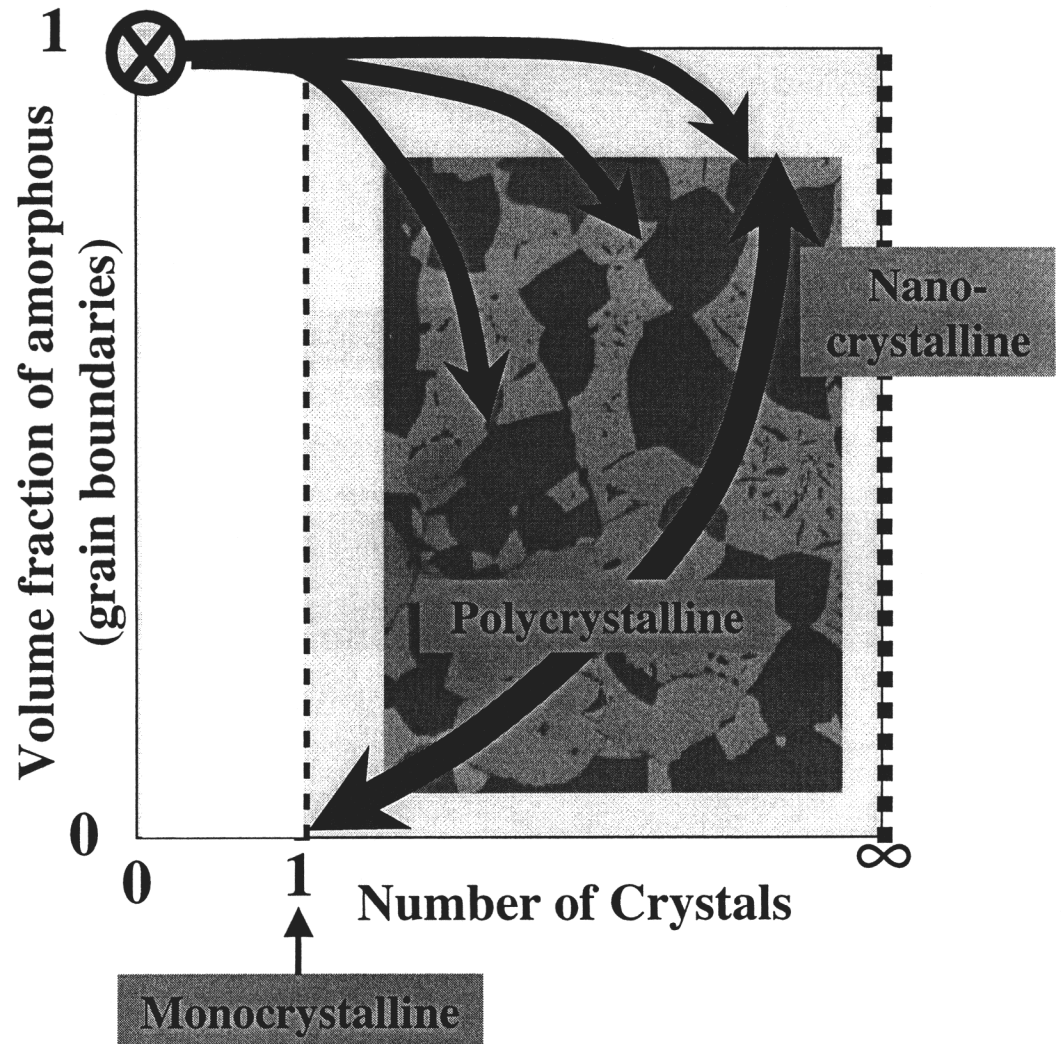



# Why Amorphous Metals?

B-39

### Hardness

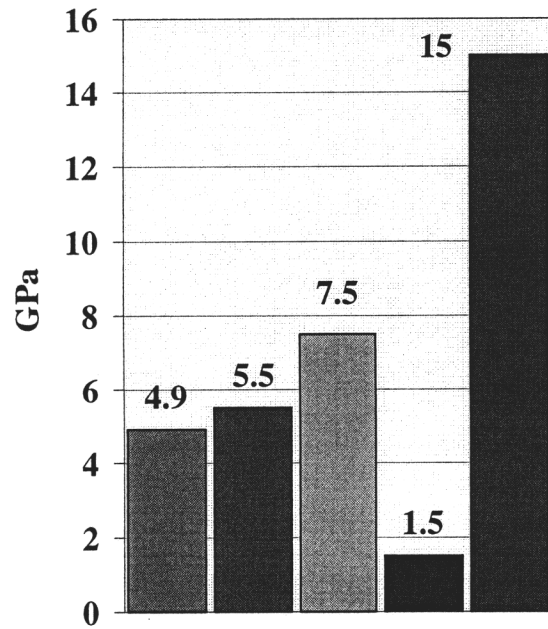

### Strength

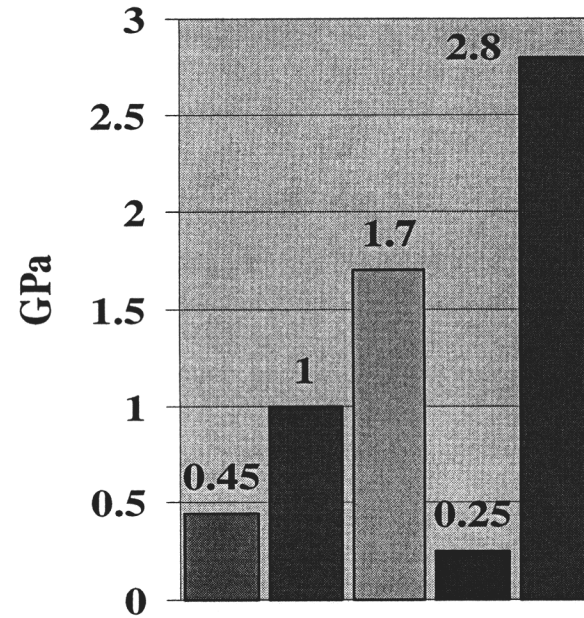

### Fracture Toughness

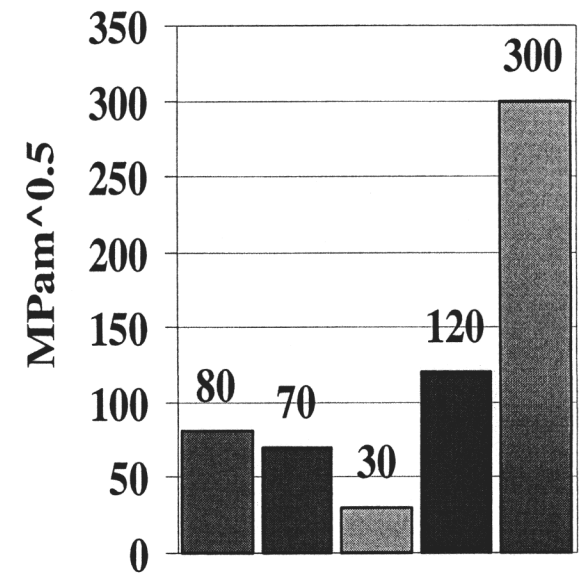

**Steels**  
Carbon Stainless   
High Strength Amorphous   
Tool

**Amorphous Metals are in a Class of their Own!**

# Unexpected Strain Rate Response in SAM



- Dynamic toughness of SAM is **EXACTLY** the opposite of conventional materials -- toughness increases with strain rate
- Conventional materials exhibit reduced toughness with increasing strain rate
- Speculate that combination of high strength, hardness and dynamic fracture behavior will translate into useful naval and other structures

04-2

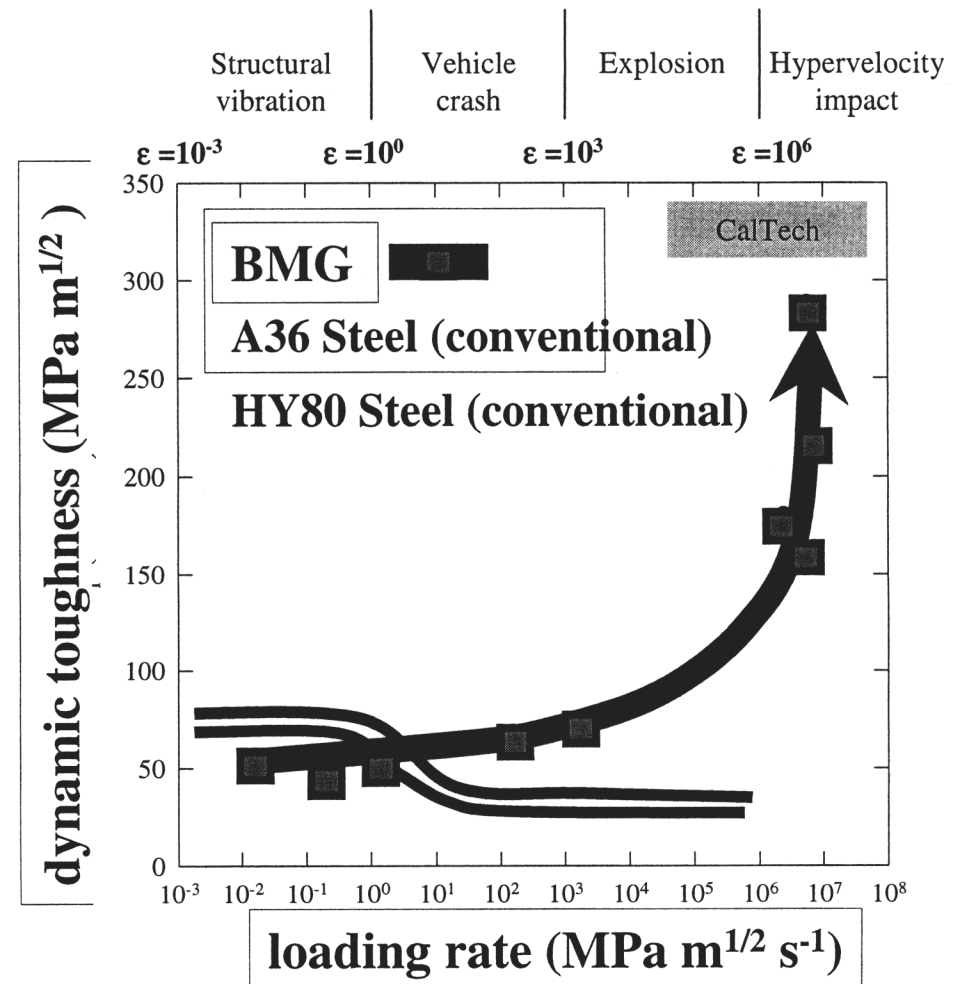

# Wear and Corrosion



14-8

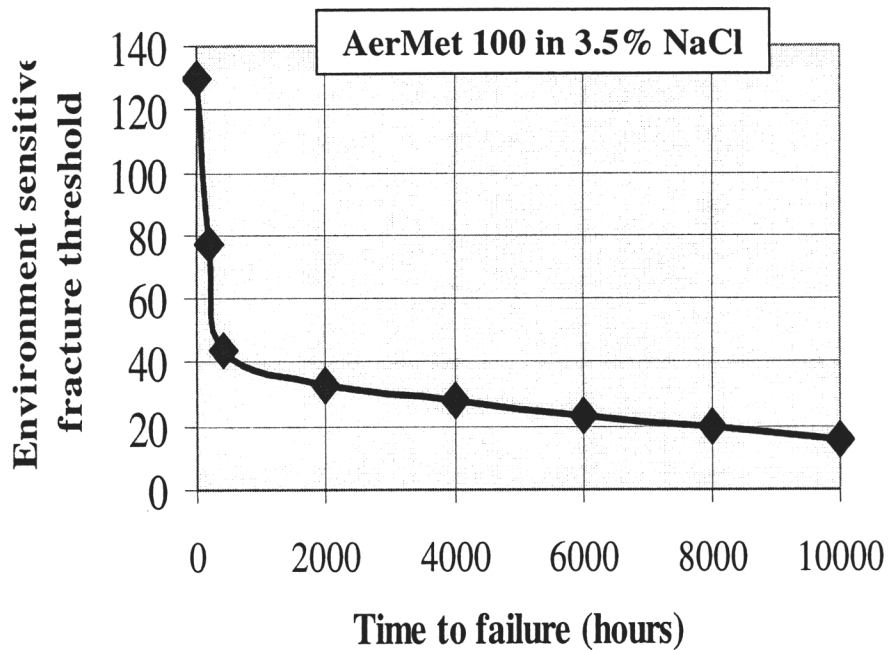

## Crystalline Localized Corrosion

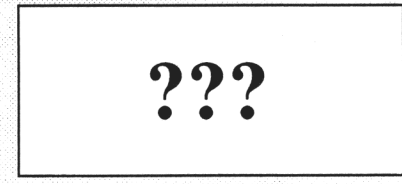
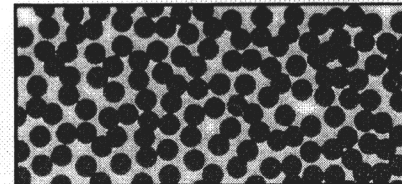
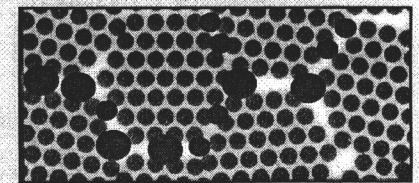
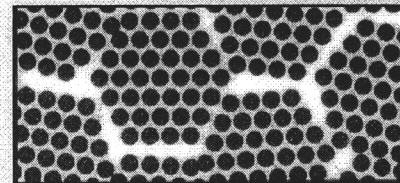

???

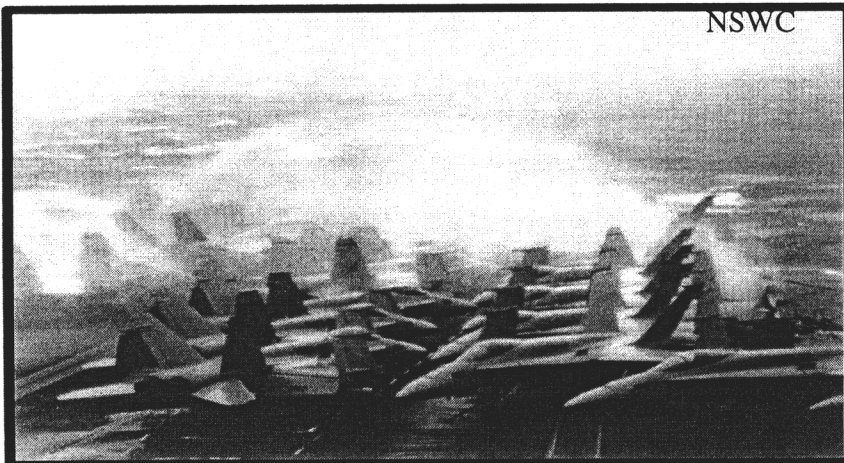

## Amorphous Materials;

- Do NOT have grain boundaries (NO corrosion initiation sites)
- Very high wear resistance (better than  $\text{Si}_3\text{N}_4$ )
- Damage tolerant



**Accelerated Insertion of Materials Initiatives. Wax &  
L. Christodoulou**

**DARPA/DSO**

**R. Meilunas (NAWC AD) and R. Dutton (AFRL)**

B-42

## Program Status

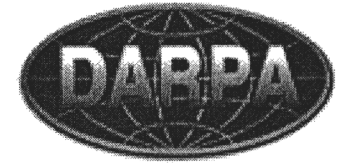

---

**Awards of 15- month “Base Programs” to three teams lead by:**

- 1. Boeing Company (PMC)**
- 2. Pratt and Whitney (Metal)**
- 3. GE Aircraft Engines (Metal)**

B-43

**DARPA and its Agents (NAWC and AFRL) rationale for multiple base program awards of 15-month duration is to allow the performers to achieve substantial progress in their AIM concepts and to demonstrate the viability of their approach. It is anticipated that after this initial 15-month period DARPA will down-select to those programs that have demonstrated the optimum strategy, accomplished significant progress, and offer the greatest likelihood to meet the overall AIM program objectives.**

# Perspective



---

**AIM is a focused mathematics- and computation-intensive materials initiative directed to address a DoD need:**

**It is intended to:**

**Establish a methodology for increasing the speed of material insertion into new systems**

**Reduce the cost of such insertions**

**Reduce the risk of using new materials or employing in new applications**

**Reduce the materials/system design gap**

**It is not:**

**A modeling program**

**A materials design/processing activity**

B-44

# The Disconnect!



**Significant Disconnect Between Materials Development and the Design/Use of Materials in Components/Systems**

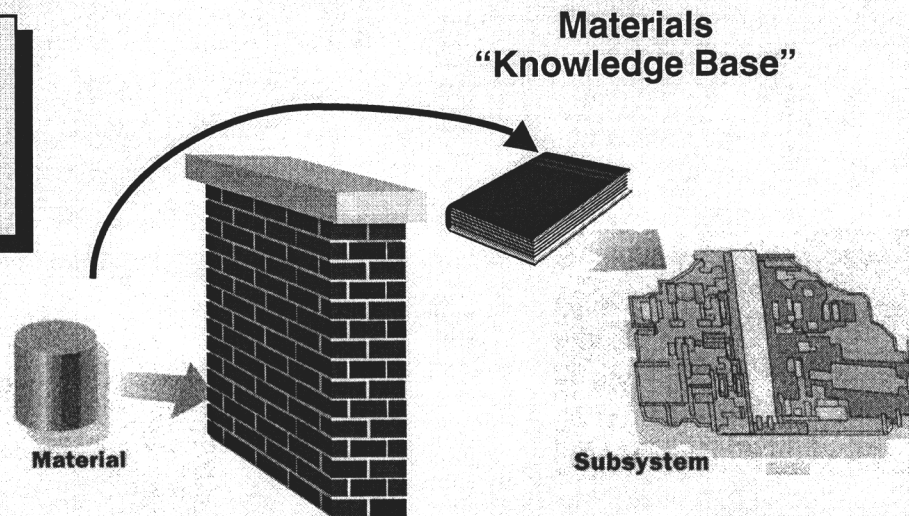

13-45

## Materials Development

- Highly Empirical
- Testing Independent of Use
- Existing Models Unlinked
  - Known Alloy to Reliable Part - 36 Months
  - Steels for Navy Landing Gear - 15+ Years
  - Lightweight Composites for Army Vehicles - 15+ Years
  - Ceramics for Engines - 20+++ Years
  - Changing Ship Steels - 7-10 Years

## Systems Design

- Materials Input from "Knowledge Base" of Data (Data Sheets, Graphs, Heuristics, Experience, etc.)
- System/Sub-System Design is Heavily Computational and Rapid
  - Clean Sheet of Paper to Engine Design - 30 Months
- Well Established Testing Protocols

# The Problem



- **Current, Empirical Approach to Materials Development is Time (& Cost) Intensive**
  - **Small, Cautious Steps in Compositional Variations, Scale-up and Processing Changes**
  - **Multiple Iterations Produce Limited (Non-statistical) Data**
  - **Early Concentration on “Primary” Properties**
  - **Does Not Address Designer’s Issues and Needs**
- **Real Insertion Windows Often Open Only for a Short Time**
  - **Materials Are Seldom “Production Ready”**
  - **Risk-to-Benefit Too High**
- **Outcome**
  - **Designers Choose “Known” Material -- Window Closes!**
  - **Significant Impact on Performance/Cost of Past and Future Defense Systems**

B-46

# Objective



---

Establish a methodology for accelerated insertion of materials into defense platforms & structures. Specifically, we intend to:

- Establish an information-driven quantitative framework for materials development and validation
- Orchestrate models, simulations, and experiments to maximize information content
- Identify strategies for design using models, computations, and experiments that yield equivalent information
- Develop validate and demonstrate tools for accelerated insertion.

# Technical Approach

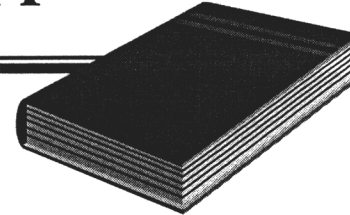

## Phase I

- Establish a Design Knowledge Base (DKB) for a currently employed material
- Populate with data from models and/or experiments directed by the new methodology
- Fully integrate into (new or existing) design tools
- Validate against known material database (metals and composites)
- Demonstrate reduction in insertion time

## Phase 2

- Establish a DKB for either a new material or an existing material in a new application

# “Knowledge Base” Definition

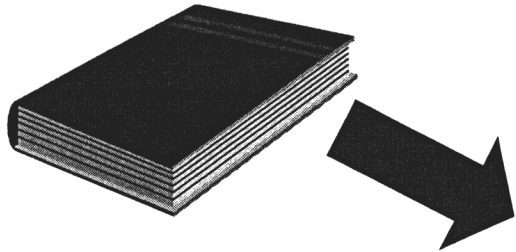
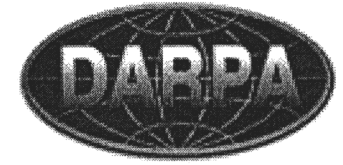

- **Everything designer needs to design a component and decide to use a material**
  - Validation of critical properties (with confidence limits)
    - F (composition, processing, structure, use conditions, ...)
  - Confidence in scale-up, design and control of process(es)
  - Confidence in manufacture of parts and components (e.G., Weldability)
  - Detailed assessment of costs
  - Predictable reliability and life
  - Etc....

# “Knowledge Base” Construction Issue

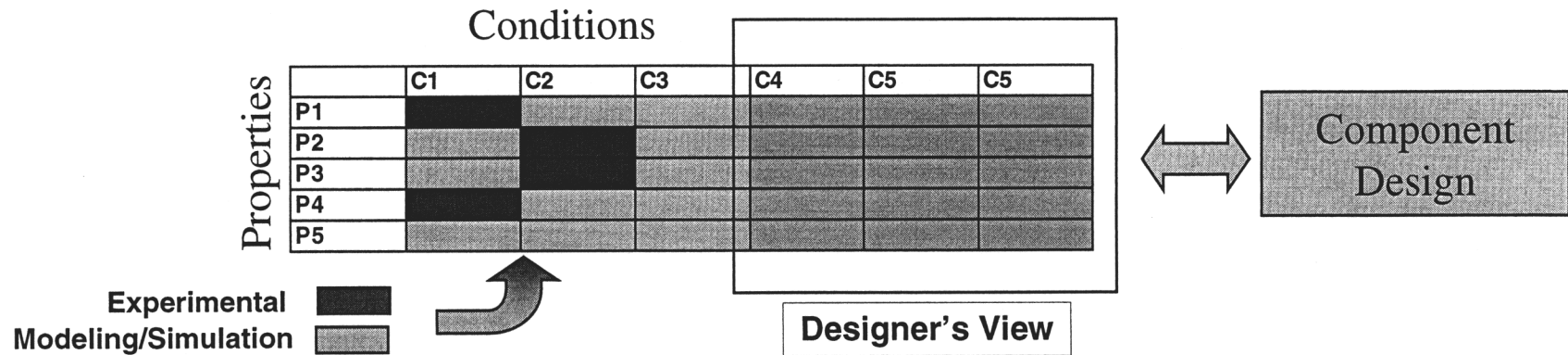

B-50

- **R&D Driven by:**

- Necessary “Information” and Its Needed Accuracy for Component Design and Use
- Connectivity Between Knowledge Base Data and Component Design Models

- **Use of Experiment or Models Transparent to User!**

# Example of an “Object-oriented” Modular Approach



Distributed Object-Based  
Modeling Environment (DOME),  
MIT

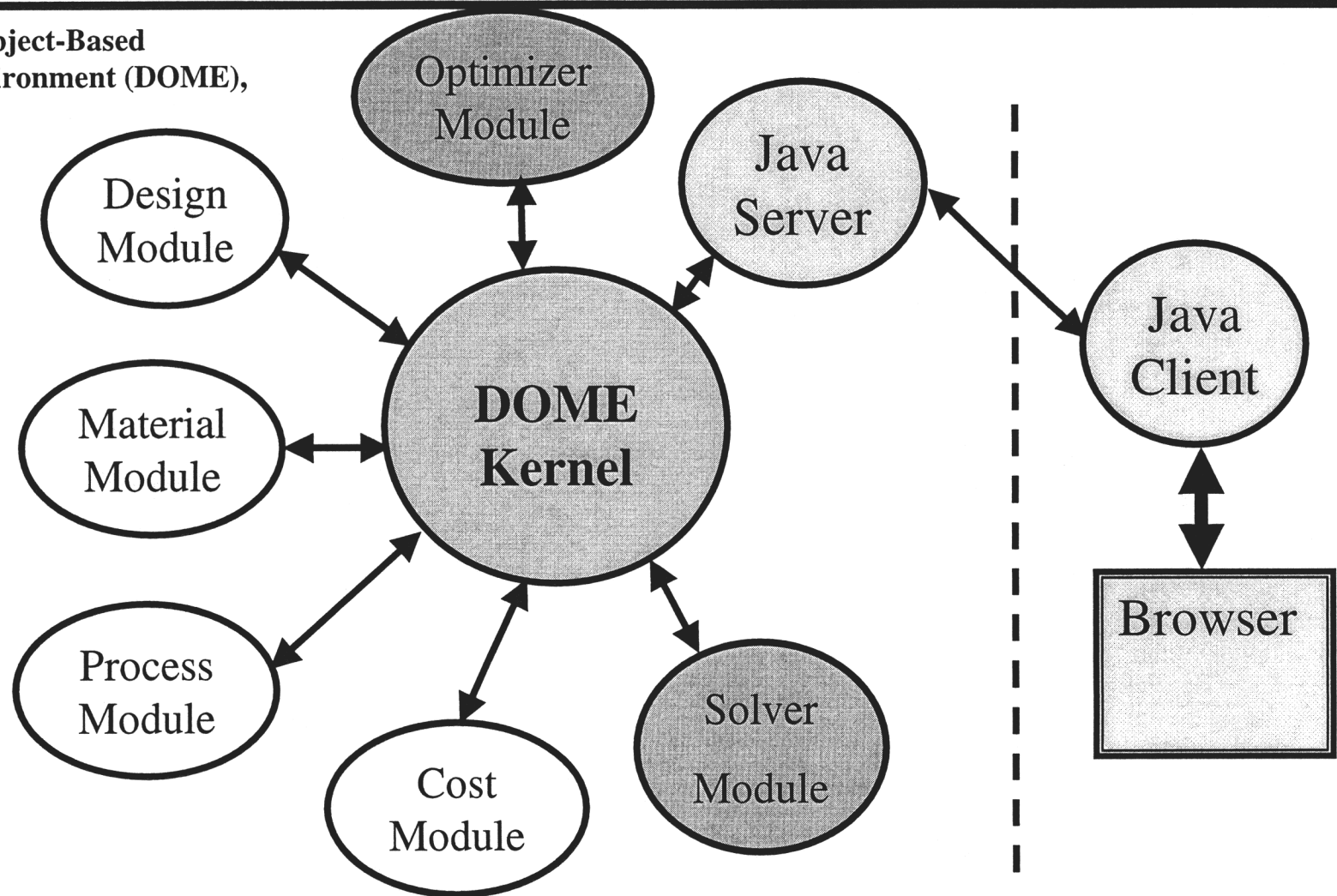

B-51

Adapted from: Nicola Senin, Roberto Groppetti, A. Rossi, David R. Wallace, Integrating Manufacturing Simulation Tools Using Distributed Object Technology, 4th IEEE/IFIP International Conference on Information Technology for BALANCED AUTOMATION SYSTEMS in Production and Transportation, Berlin, September, 2000.

# Challenges and Issues - Uncertainty



## Uncertainty Sources

- **Estimation of error and uncertainty as function of physical or mathematical complexity.**
- **Development of formulations that minimize sensitivity or are insensitive to uncertainty.**
- **How to collect data to determine, minimize or control uncertainty?**
- **Uncertainty reduction schemes using high fidelity information “fusion” from low fidelity sources.**
- **Exploitation of knowledge of uncertainty.**

- **Model errors**
  - **Parametric and nonparametric sources**
  - **Initial formulation or hypotheses**
  - **Model reduction**
  - **Unknown sources of uncertainty**
- **Data**
  - **Input uncertainties**
  - **Numerical errors and uncertainty**
  - **Experimental accuracy**
- **Propagation of uncertainty**

**Quantifying Uncertainty Is Critical to Reliable and Robust Design**

# Materials and Manufacturing Technology

## Overview for Supersonic Applications

B-53



**26 June 2001**

**Edward Hermes**

**Materials and Manufacturing Directorate**

**AFRL/MLSC**

**937-904-5046**

**edward.hermes@wpafb.af.mil**



## ML Mission / Vision



**Plan and execute the USAF program for materials and manufacturing in the areas of basic research, exploratory development, advanced development and industrial preparedness. Provide responsive support to Air Force product centers, logistics centers, and operating commands to solve system and deployment related problems and to transfer expertise.**

*Aerospace materials and manufacturing leadership  
for the Air Force and the nation.*

13-54



# Current Core Technology Areas (CTAs)



- **Polymers**
- **Metals**
- **Organic Matrix Composites**
- **NDE**
- **Ceramics**
- **Tribology/Coatings**
- **M&P for Sensors**
- **Laser Hardened Materials**
- **Manufacturing Technology**
- **Systems Support**
- **Air Expeditionary Forces (AEF) Technologies**

B-55



# CTA Leaders



B-56

<b>Polymers</b>	<b>Dr. Bob Evers</b>	<b>AFRL/MLBP</b>	<b>937-255-9158</b>
<b>Metals</b>	<b>Ms. Kathy Stevens</b>	<b>AFRL/MLLM</b>	<b>937-255-1305</b>
<b>Organic Matrix Composites</b>	<b>Mr. Scott Theibert</b>	<b>AFRL/MLBC</b>	<b>937-255-9070</b>
<b>Nondestructive Evaluation</b>	<b>Dr. Jim Malas</b>	<b>AFRL/MLLP</b>	<b>937-255-9802</b>
<b>Tribology and Coatings</b>	<b>Dr. Jeff Zabinski</b>	<b>AFRL/MLBT</b>	<b>937-255-4860</b>
<b>Ceramics</b>	<b>Dr. Allan Katz</b>	<b>AFRL/MLLN</b>	<b>937-255-1351</b>
<b>M&amp;P for Sensors</b>	<b>Mr. Bob Denison</b>	<b>AFRL/MLPO</b>	<b>937-255-4474x3208</b>
<b>Laser Hardened Materials</b>	<b>Lt Col Bill Cowan</b>	<b>AFRL/MLPJ</b>	<b>937-255-3808x3148</b>
<b>Manufacturing Technology</b>	<b>Mr. Dennis Hager</b>	<b>AFRL/MLM</b>	<b>937-904-4347</b>
<b>Systems Support</b>	<b>Mr. Gary Kepple</b>	<b>AFRL/MLS</b>	<b>937-656-6054</b>
<b>AEF Technologies</b>	<b>Mr. Stan Strickland</b>	<b>AFRL/MLQ</b>	<b>850-283-6326</b>



# Materials & Processing Technology Thrusts



## M&P for Structures and Propulsion

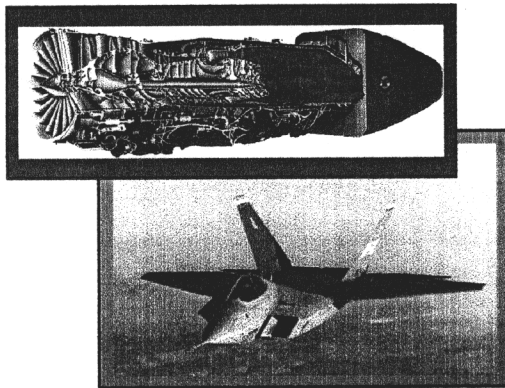

## M&P for Sensors and Survivability

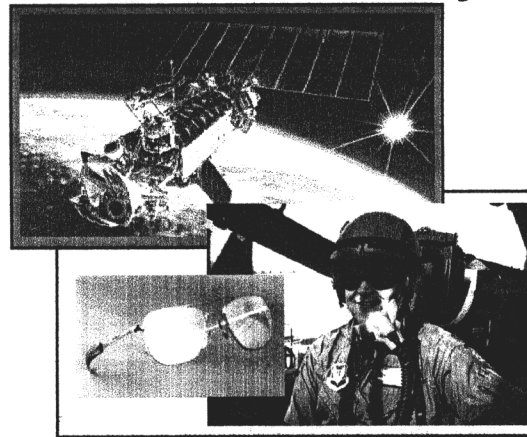

## M&P for Sustainment and Deployment

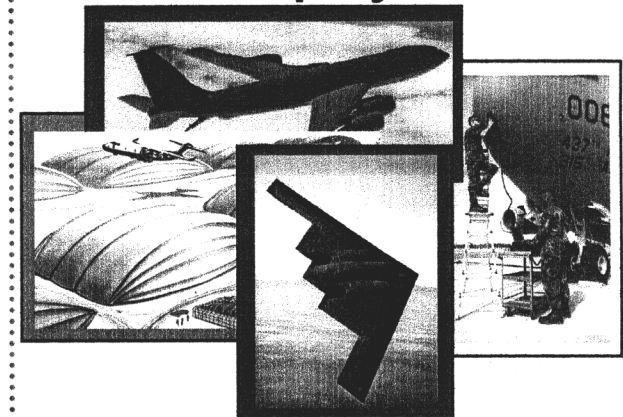

13-51

### Core Sub-Thrusts

- Metals
- Composites
- Ceramics

- Sensor Materials
- Laser Hardened Materials
- Polymers

- NDE
- Systems Support
- AEF Technologies
- Coatings

### Key Programs

- High Cycle Fatigue
- Composites Affordability
- Thermal Protection
- IHPTET Materials
- IHPRPT Materials

- IR Sensor Materials
- Laser Protective Coatings & Devices
- Power Generation
- Polymeric Materials

- Aging Systems NDE
- Agile Combat Support
- Failure Analysis
- Engine Life Extension 5
- LO Maintainability



# Manufacturing Technology Thrusts



## ManTech for Structures and Engines

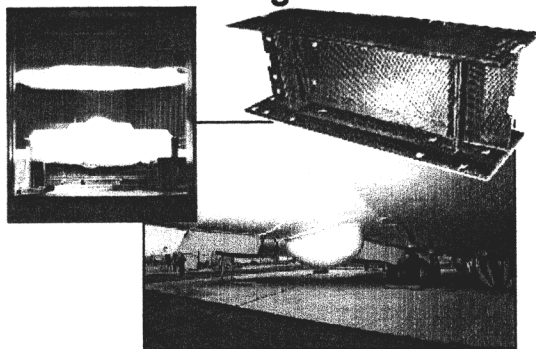

## ManTech for Electronics and Sensors

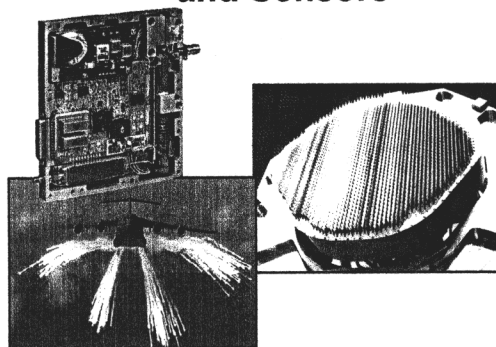

## ManTech for Sustainment



### Core Sub-Thrusts

- Metals Processing & Fabrication
- Composites Processing & Fabrication
- Manufacturing Modeling & Simulation
- Advanced Industrial Practices
- Electronics Fabrication & Assembly
- Electro-Optic Components
- Microwave Devices
- Radar Systems
- Repair/Refurbishment Processes
- Parts Obsolescence
- Nondestructive Evaluation

### Key Programs

- Composites Affordability Initiative
- Metals Affordability Initiative
- Forging Supplier Initiative
- Casting Supplier Initiative
- Multi-functional Radomes
- Modeling & Simulation for Affordability
- Affordable Tool-Less Edge Fabrication
- Affordable Mfg. of Lo Coatings
- MEMs for IMUs
- LAIRCM (Affordable Missile Warning)
- Radar Subarray Systems
- Airborne Laser Window
- Lean Blade Repair
- Laser Shock Peening
- Electronic Parts Obsolescence
- Structural Repair of Aging Aircraft
- Lean Depot Repair
- Best Commercial Mfg. Practices
- Turbine Engine Life Extension
- Stretch Forming Simulation

B-58



# MATERIALS AND PROCESSING TECHNOLOGIES



- **Current programs impacting structures and propulsion**
  - **High Temperature PMCs**
  - **Carbon-Carbon Materials**
  - **Thermal Management Materials**
  - **Processing for Dimensional Control**
  - **IHPTET**
  - **Life Prediction / High Cycle Fatigue**
  - **....**

*Technologies that may be available for demonstration*

13-59



# High Temperature PMCs



**Goal: Sustained use 450°F & above; limited lifetime up to 700°F**

- + Environmental durability (Thermal oxidative and hygrothermal stability)
- + Low-cost processing/material
- + Environmentally friendly

B-60

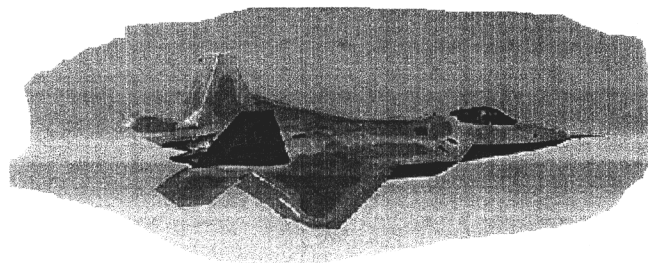

**F-22, JSF: BMI matrix composite offers higher design allowables, lighter structure, inexpensive processing**

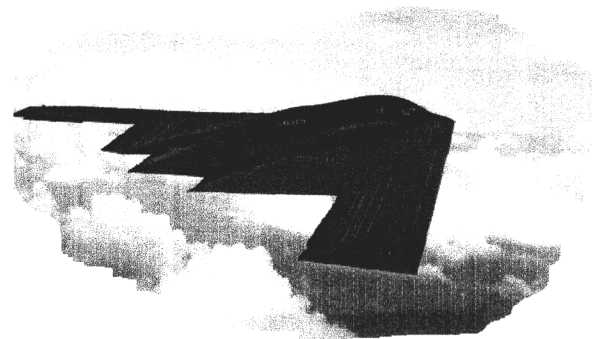

**B-2, F-117A, F119: High temperature organic matrix composites allow high temperature structure in engine and exhaust impingement applications**

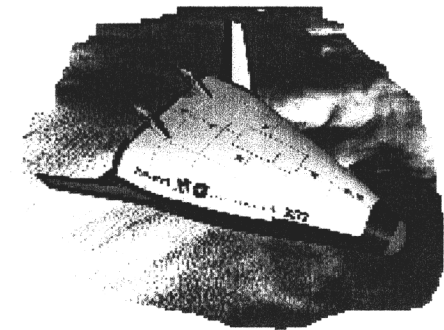

**Hot internal structure reduces weight of thermal protection system, lighter engines**



# Thermal Management Materials C-C Heat Exchanger



F-18 Primary Heat Exchanger

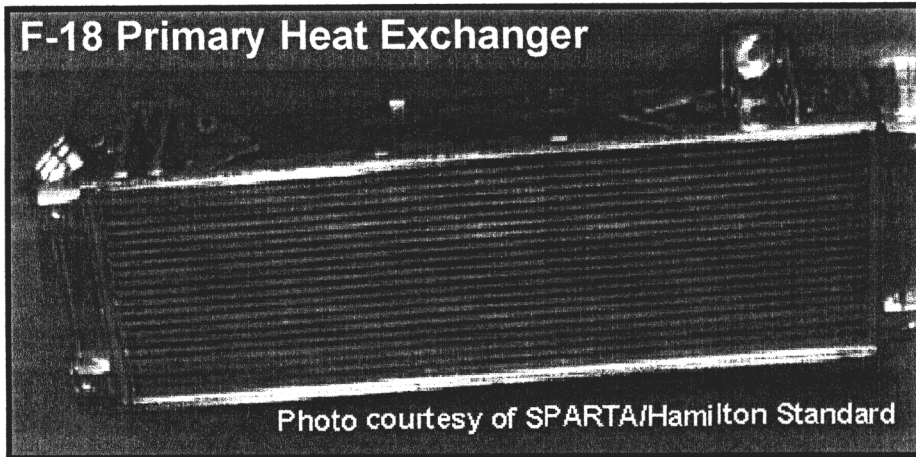

Photo courtesy of SPARTA/Hamilton Standard

13-61

## OBJECTIVE

- Develop oxidation Resistant C-C for 1200F heat exchangers

## TECHNICAL APPROACH

- Generate oxidation protection data for coatings and inhibitors
- Develop coating technique for a C-C HX core
- Demonstrate oxidation protection scheme for C-C primary HX
- Deliver material property data

## BUSINESS DETAILS

- Contract Number(s): CA# F33615-99-2-5216
- Contractor(s): Honeywell International
- Start Date: Aug 1999 /37months
- Project Manager: Roland Watts AFRL/MLBC  
*e-mail: Roland.Watts@AFRL.AF.MIL*

AF Funding:

<u>FY00</u>	<u>FY01</u>	<u>FY02</u>	<u>FY03</u>	<u>FY04</u>	<u>Total</u>
324	315	236			875

## BENEFITS

- Provide extended life, lightweight, corrosion-resistant, very efficient Environmental Control System
- Extends time between failure by 2X
- Extend range due to 40% weight reduction and increase heat exchanger efficiency by 10%
- Extension of capabilities due improved/new electronics technology



# Thermal Management Materials Carbon Foam Heat Exchanger



13-62

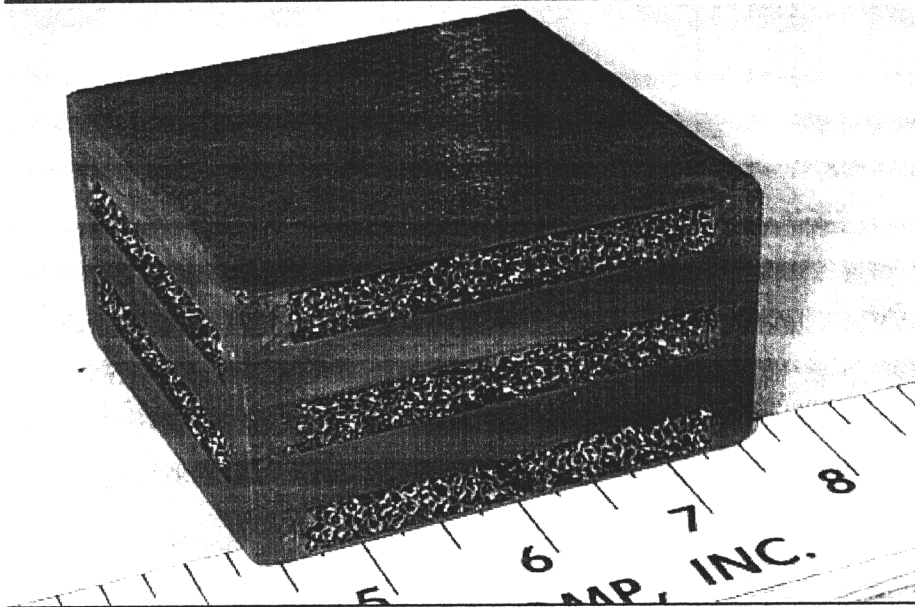

## OBJECTIVE

- Develop extremely light-weight, high conductivity composite heat exchangers

## TECHNICAL APPROACH

- Optimize open HiK pore structure and plate joint attachment
- Generate performance data using sub-scale heat exchanger
- Use data to design and fabricate full size heat exchanger to decrease volume/increase cooling capacity

## BUSINESS DETAILS

- Contractor(s): Allcomp, Inc.  
TBD
- Start Date: Oct 1999 /24 months
- Project Manager: POC: Tom Gilmour NAVAIR  
Roland Watts AFRL/MLBC  
*e-mail: Roland.Watts@AFRL.AF.MIL*

	<u>FY00</u>	<u>FY01</u>	<u>FY02</u>	<u>FY03</u>	<u>FY04</u>	<u>Total</u>
Navy Funding:	300	300				600
Air Force Funding:				150	350	500
Industry Cost Share			TBD	TBD	TBD	

## BENEFITS

- Provide extended life, lightweight, corrosion-resistant, very efficient Environmental Control System
- Extends time between failure by at least 2X
- Extend range due to 70% weight reduction and increase heat exchanger efficiency by 25%
- Increase heat transfer coefficient, h by 5X



# High Fidelity Analysis Tools



## PMCs Currently Penalized through “Factors” in Design

- True potential benefits not realized
- Lack of understanding, tools, failure criteria
- Design Limit Load: worst case, low probability

B-63

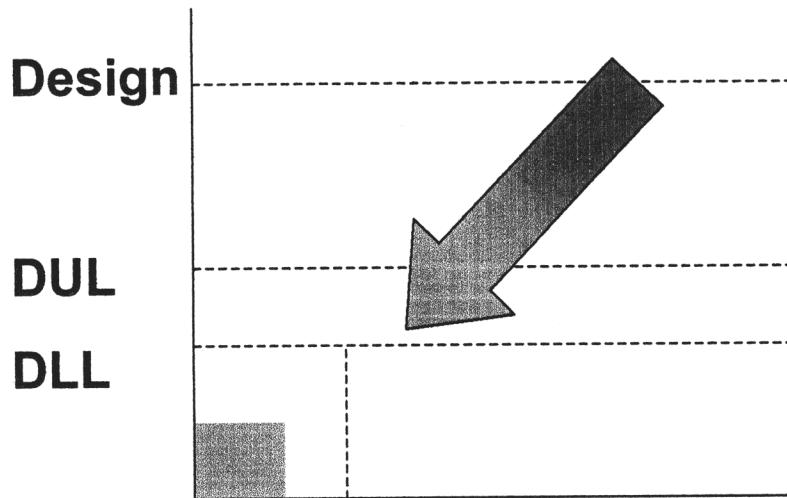

$$D = DUL * (\text{Knockdowns} \dots \text{hot/wet, open hole, } \dots)$$

# VERSUS

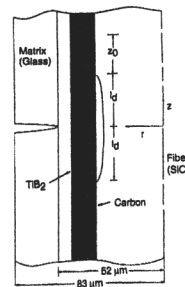
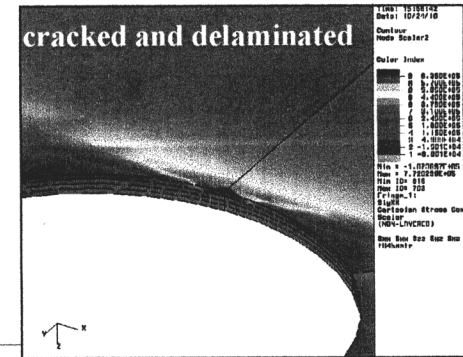

Micromechanics

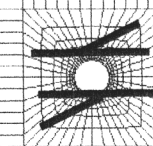

Mechanism Based Strength Prediction



# High Fidelity Analysis Tools



**VISION: UNDERSTANDING = accurate failure prediction**  
**= control of structural load paths**  
**= “real” factors of safety**  
**= minimal testing**

B-64

**3-D Stress and Fracture Analysis**  
**3-D Failure Criteria**

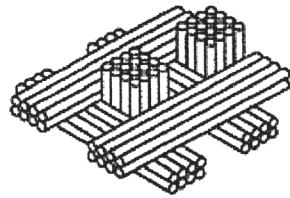

New material forms

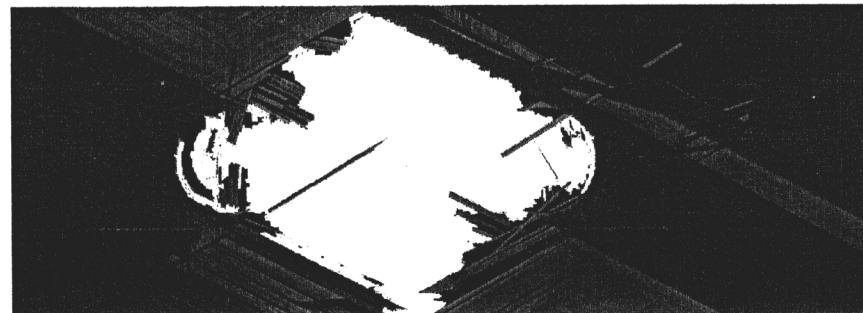

Bolted joint specimen shows complexity of failure

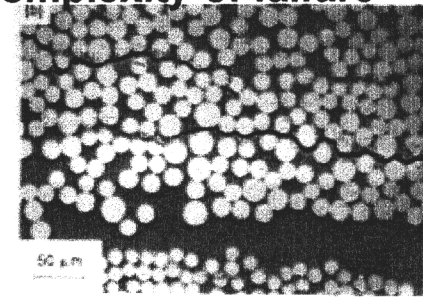

Micro-level damage

**PRACTICE: EMPIRICISM = extensive testing**  
**= weight**  
**= cost**  
**= time**



# Processing for Dimensional Control

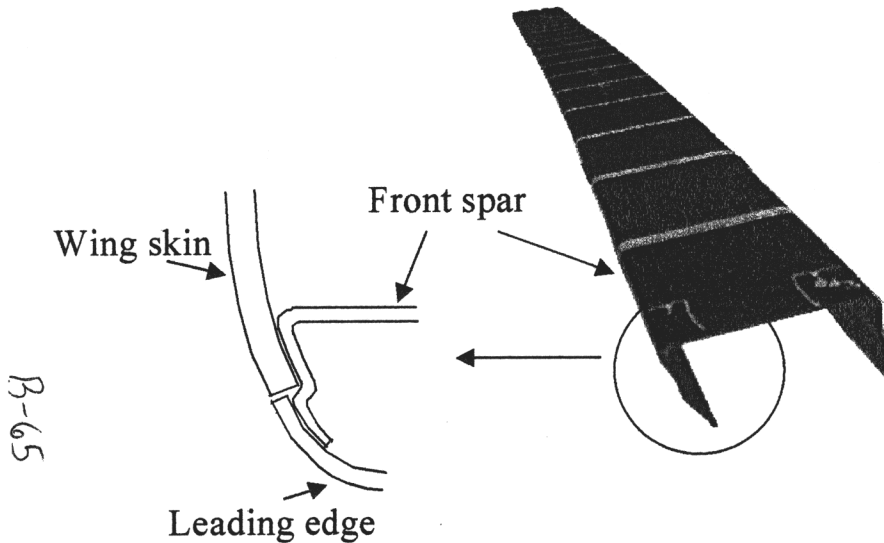

## OBJECTIVE

- Develop tools for the fabrication of composites with improved dimensional control

## TECHNICAL APPROACH

- Establish the cost and performance benefits
- Predict spring-in of as-designed part via model
- Compensate tooling based on model predictions for spring-in
- 2-D, 3-D Model; Cost Analysis

## BUSINESS DETAILS

- Contract Number(s): F33615-97-C-5006
- Contractors: Boeing
- Start Date: Nov 1997 – Nov 2001
- Project Managers: Roger Gerzeski, AFRL/MLBC  
e-mail: [Roger.Gerzeski@AFRL.AF.MIL](mailto:Roger.Gerzeski@AFRL.AF.MIL)

Air Force Funding:	PY	FY00	FY01	FY02	Total
	645	418	1352	6	1421

## BENEFITS

- Reduced assembly costs for large, integrated structures
- Bonded/joined structures enabled
- Low cost through reduced shimming, tool rework
- Processing simulation abilities for reduced cost, lead times



# High Temperature Polymer Matrix Composites

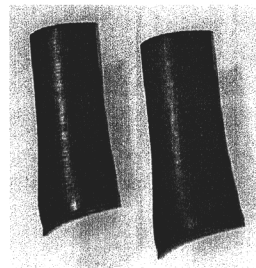
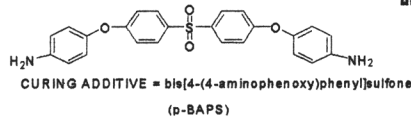
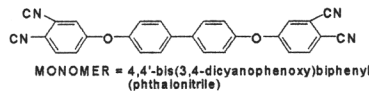
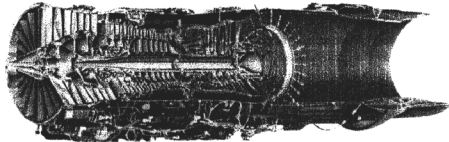

## Technology Investment Schedule As of 8 Mar 01

### Milestones

- Primary Contract Award
- Screen newly developed resin systems
- Downselect candidate resins
- Scale-up promising resin candidates
- RTM flow modeling for process optimization
- Panel characterization
- Funding 63112F

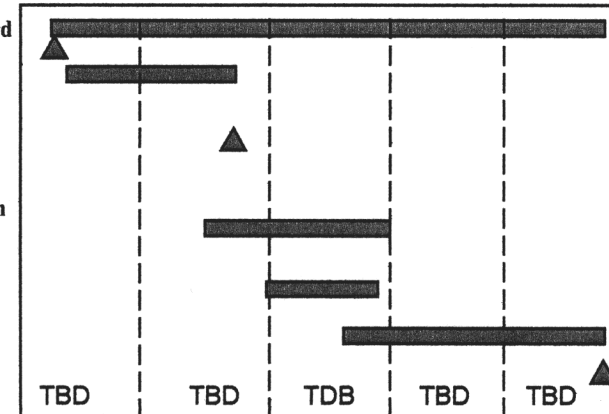

B-66

Description	Benefits to the War Fighter
<ul style="list-style-type: none"> <li>• Allow commercial deployment of new, non-toxic, environmentally durable, low-cost fabrication resin systems for high temperature applications</li> </ul>	<ul style="list-style-type: none"> <li>• Reduced weight of fan section components, enabling improved thrust-to-weight ratios and greater mission capabilities</li> </ul>
<h3 style="text-align: center;">Technology</h3>	<ul style="list-style-type: none"> <li>• Dramatically reduced costs of high temperature polymer matrix composite engine and airframe applications</li> </ul>
<ul style="list-style-type: none"> <li>• Develop polymers for composites used in turbine engine applications of 550-700°F</li> <li>• Develop and demonstrate low-cost fabrication methods for high temperature polymer composites</li> <li>• Enhance the hygrothermal stability of high temperature polymer matrix composites</li> </ul>	<ul style="list-style-type: none"> <li>• Improved environmental durability</li> <li>• Decreased toxicity during manufacturing and repair</li> </ul>



# ADVANCED M&P FOR IHPTET



## Research Areas

**1996**

$\gamma$  TiAl

Adv. Intermetallics (Mo, Nb)

CMCs

Ti-MMCs

Bearing Materials

Fluids, Lubricants

Hi Temperature OMCs

**2000**

$\gamma$  TiAl for Fracture Critical Applications

Advanced Intermetallics (Mo, Nb)

Affordable Processing

HCF

2400°F CMCs

Hi Temperature OMCs

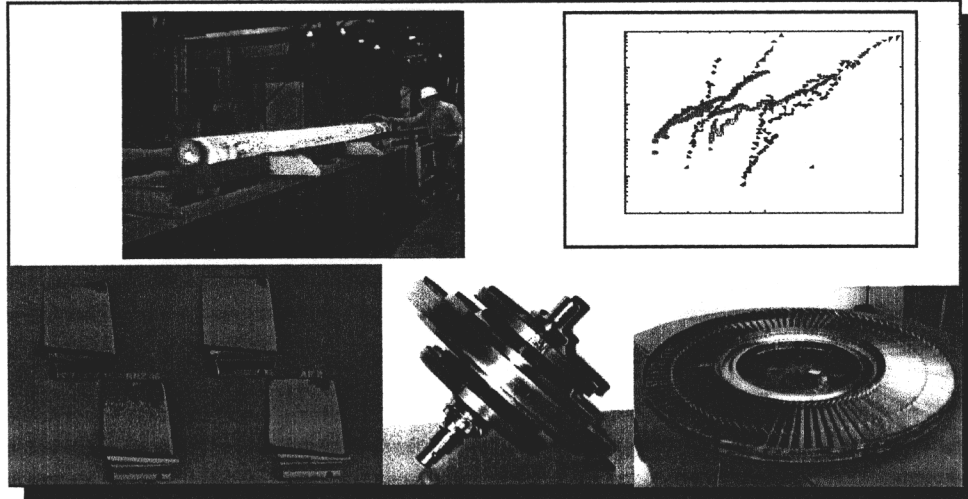

B-67

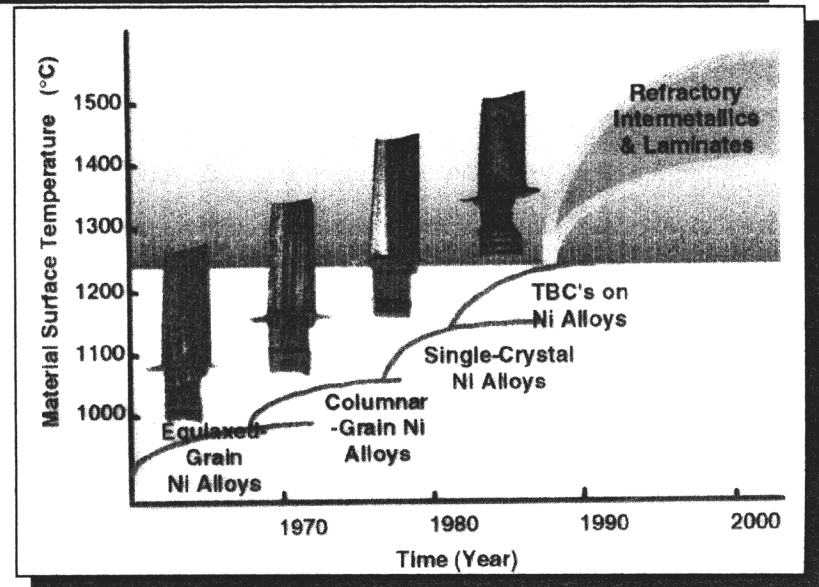
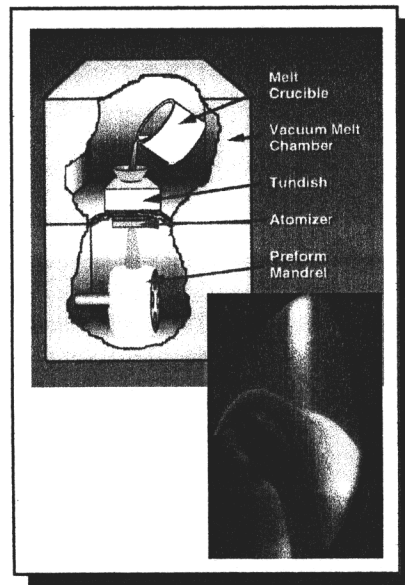
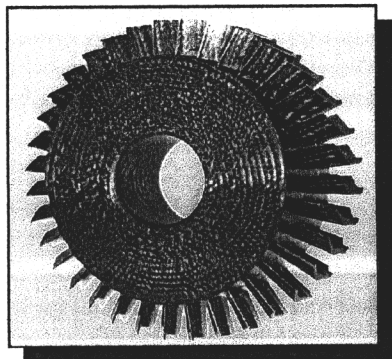



# MANUFACTURING TECHNOLOGY



- **Current programs\* impacting structures and propulsion**
  - **Composites Affordability Initiative**
  - **Metals Affordability Initiative**
  - **Forging Supplier Initiative**
  - **Casting Supplier Initiative**
  - **Laser Shock Peening**
  - **Engine Rotor Life Extension**

B-68

**\*TRL5/6 within ~5 years**



# COMPOSITES AFFORDABILITY INITIATIVE

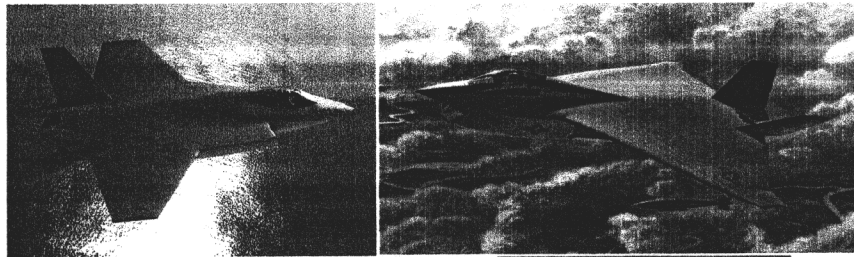

B-69

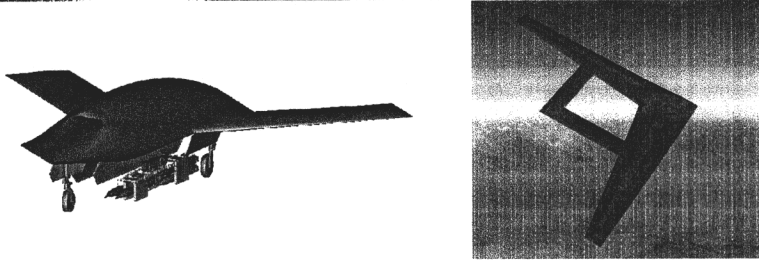

## Objective

- Provide technologies that will enable an order of magnitude reduction in acquisition costs of advanced composite structures

## Approach

- National partnership - Government and industry
- Utilize revolutionary design / manufacturing concepts
- Couple technology development with transition demos

## Deliverables

- Affordable design/manufacturing/assembly technologies
- Supporting structural analysis and non destructive evaluation tools
- Cost model for composite airframe designers
- Validation of technologies, performance, affordability and ROI through transition demonstrations

## Milestones

JSF phase 2 demos complete	FY01
Innovative M&P specifications complete	FY03
Full scale V-22 spindle demo complete	FY04
Full scale UCAV structural demo complete	FY04
Complete cost analysis tools validation	FY05

**Contract Numbers: F33615-98-C-5103 through 06**

<u>Funding(\$K)</u>	<u>97-00</u>	<u>FY01</u>	<u>FY02</u>	<u>FY03</u>	<u>FY04</u>	<u>FY05</u>
AF ML 7.8	16170	5000	5000	5000	5000	3500
AF ML 6.3	530	0	0	0	0	0
AF ML 6.2	1000	0	0	0	0	0
AF VA 6.3	2184	1988	944	2044	1524	0
AF VA 6.2	2751	0	0	0	0	0
Navy 7.8	22000	1075	2675	2100	850	2550
JSF Program	500	0	0	0	0	0
Industry	43362	8167	9450	9650	7450	9000
<b>TOTAL</b>	<b>88497</b>	<b>16230</b>	<b>18069</b>	<b>18794</b>	<b>14824</b>	<b>15050</b>

## Customers

- Near Term - JSF, UCAV, V-22, F-22, SensorCraft
- Far Term - Rotorcraft, land, sea, and space systems

## Benefits

- Significant improvements in composites affordability
- Increased system performance via increased composites usage
- Advanced aerospace industry state-of-the-art

## Implementation

- Near term: Phase 2 technology included in the JSF EMD proposals

## Related Efforts

- Rotary Wing Structures Technology Demo - Army
- Knowledge & Processing Tools for Manufacturing of Affordable Composite Structures - Army



# METALS AFFORDABILITY INITIATIVE

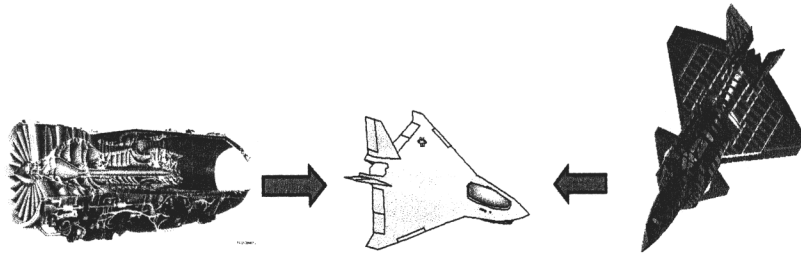

## ENGINES

- 80% Metal Components
- 20-25% System Cost

## AIRFRAME

- 67% Airframe Wt. Metal
- 33% System Cost

**Objective:** Address key drivers to recurring engine & airframe costs through affordable metal products

- Collaborative effort with industry
  - 25% industry high quality cost share
- Reduce metal component acquisition cost by 50%
  - Reduce time to market
  - Pervasive technology advancement

## Technical Challenges:

- Efficient Manufacturing
- Collaborative Design
- Reduced Part Count
- Improved Yield
- Lower Cost Alloys
- Reduced Time to Market
- Reduced Inspection Steps
- Reduced Maint'nce Actions

## CONTRACT BACKGROUND

Contract: F33615-99-3-5216/5215  
 Contractor: Pratt & Whitney  
 Start: July 99  
 Duration: 84 Months  
 Project Engineer: Kevin Spitzer

## Gov't Funding Profile (\$K)

	FY99	FY00	FY01	FY02	FY03	FY04
(7.8)	\$1700		\$3800	\$2000	\$3000	\$4000
OTHER	\$4850	\$8515	\$14215	\$5160	\$3120	\$1375

## Payoffs

- Reduced Acquisition and Retrofit Costs
  - Threshold: 30%
  - Goal: 50%
- Initial Implementation in JSF
- Aircraft in production (F-22, F/A-18E/F, V-22)
- Mature aircraft (F-15, F-16, C-17, C-130, F/A-18 C/D)
- Unmanned Air Vehicles
- Space Applications

**A Robust, Responsive Supplier Base for Defense and Commercial Metals Products**

B-70



# FORGING SUPPLIER INITIATIVE

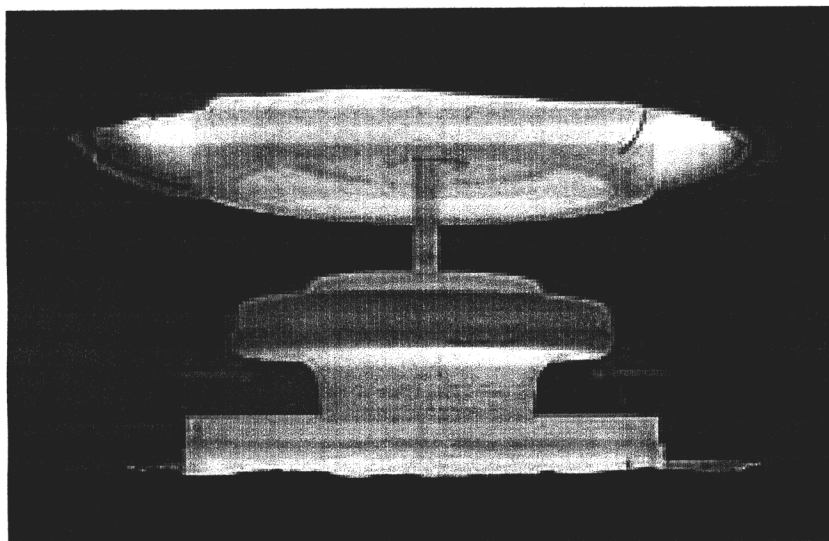

13-71

## OBJECTIVE

- Achieve a 35% to 40% cost reduction for current and future Air Force and Navy airframe and propulsion forged components by attacking affordability issues through the forging supply chain

## APPROACH

- Use of value stream analysis to identify areas of opportunity
- Address shop floor, above the shop floor and business practice topics
- Extension of corporate lean activities (i.e: Navy, R&D base)
- Execution of plan with cost reduction demonstrations

## DELIVERABLES:

- Implemented improved practices and processes
- Establishment of the "process of change" for transition

## **BUSINESS STRATEGY**

- Contract Number: F33615-99-2-5303
- Contractor: Pratt & Whitney - West Palm Beach, FL
- Start Date: MAY 99 / 46 months
- Phase I: MAY 99 - MAY 00 / 12 months
- Project Engineer: Kevin Spitzer AFRL/MLMP
- Air Force Funding:

	FY99	FY00	FY01	FY02	FY03	TOTAL
AF ManTech	600	2000	3000	2000	600	8200
AF ManTech			150*	150*	50*	350*

\*MLMR Transition to forgings simulations

- NAVY ManTech Funding & Participation (NCEMT)

## CUSTOMERS

- Joint Strike Fighter (JSF) Airframe & Propulsion
- F-22 & F-119
- F/A-18E/F & F414

## BENEFITS

- 35 to 40 percent reduction in cost of forged product
- Joint service coordinated activity attacking affordability within the forging sector

## IMPLEMENTATION

Process improvements and cost reducing practices and processes will be implemented along the entire value stream for forged products, including Engine & Airframe OEM's, Forging Suppliers, and Raw Material Suppliers

## RELATED EFFORTS

- AFRL/ML Metals Affordability Initiative
- AFRL/ML Engine Supplier Base Initiative



# CASTING SUPPLIER INITIATIVE

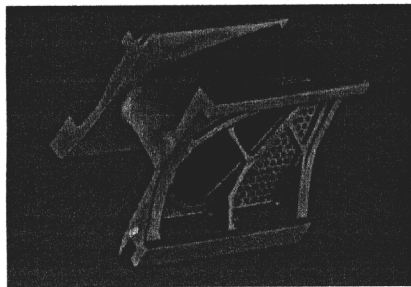

Airfoils

## Structural Castings

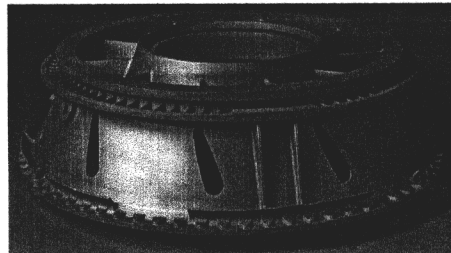

B-7a

### OBJECTIVE

Reduce the cost of components for man-rated gas turbine engines through cycle time reduction with an accompanying increase in quality brought about through the application of LEAN practices and principles.

### APPROACH

- Vendor lead program teamed with industry and government to identify and attack shop floor and above the shop floor issues
- Define an infrastructure which is lean and promotes continuous improvement toward "world class"

### DELIVERABLES

- Implemented LEAN Processes
- "Legacy" Document
- Self-sustaining Industry Forum for Continuous Improvement

### CONTRACT BACKGROUND

Contract F33615-95-2-5555  
 Contractor: Howmet Whitehall MI  
 Start Sep 95  
 Duration 78 Months  
 Project Engineer Glenn Ormbrek

Funding	FY98	FY99	FY00	FY01	TOTAL
Prior	\$4300	\$4000	\$3500	\$3500	\$20M
\$4600					

### CUSTOMERS

Casting Sector Suppliers, OEMs, DoD

### BENEFITS

- 50% improvement in quality as related to structural rework, and airfoil tolerance and single crystal scrap
- 25-50% improvement in cycle time as related to production cycle time, tooling procurement time, and new part design & process development time
- Build stable and cooperative relationships internally and externally, to implement cultural change in an terorganizational environment

### IMPLEMENTATION

Fielded Systems, F119/F-22, JSF

### Related Efforts

Forging Supplier Initiative, Metals Affordability Initiative



# MANUFACTURING TECHNOLOGY FOR AFFORDABLE LASER SHOCK PEENING

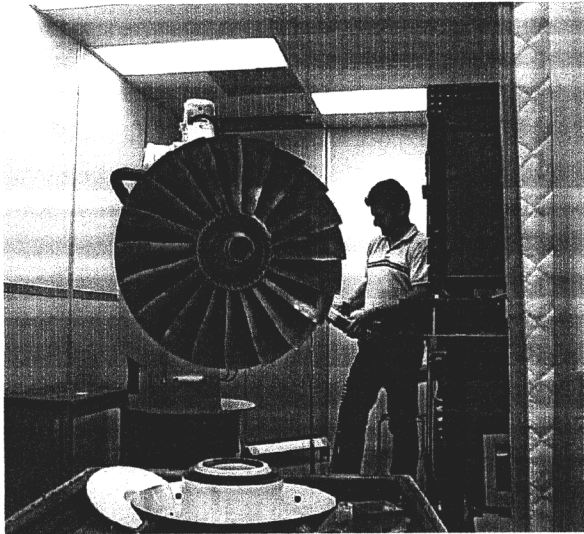

B-73

**Objective:** Mature LSP production process capability and implement an affordable production capable LSP manufacturing cell for applications to gas turbine engine blades and other fatigue critical components.

**Technical Approach:**

- Develop and implement advanced controls, monitors, and semi-automated processing sub-systems
- Design, fabricate, and implement an LSP Mfg. Cell (LSPMC)
- Demonstrate a production capable laser peening system at an aerospace user's facility
- Develop a commercial market for laser shock peening

**Deliverables:** Two production LSP systems. One installed and operated by LSPT. The second in production supporting the GE gas turbine engine production.

## CONTRACT BACKGROUND

**Business Strategy:** Cost Share Effort with Air Force & Industry

**Contract #:** F33615-98-C-5150

**Contractor Team:** LSP Technologies (Lead)

General Electric, Pratt & Whitney

Commercial Users

**Start Date/ Duration:** Aug 98 48 Mo

**Project Engineer:** D. W. See AFRL/MLMP

Funding Profile:	<u>FY98</u>	<u>FY99</u>	<u>FY00</u>	<u>FY01</u>	<u>FY02</u>	<u>Total</u>
(MT) (\$ K )	350	1350	1750	1600		5050
(LSPT) (\$ K)	50	365	265	60		740

**Customers:**

- First Level: LSP Technologies , GE Aircraft Engines, Pratt & Whitney, and selected application partners TBD
- Second Level: F101, F110, F119, etc.

**Benefits:**

- Reduced Laser Shock Peening costs by 50% to 75% over current baseline costs
- Increased throughput by six to nine times over current baseline
- Increased leading edge damage tolerance by 15 X for critical gas turbine blades
  - Increase engine durability
  - Reduce maintenance costs

**Implementation:**

- LSPMC implementation at LSP Technologies
- Advanced Controls and monitors implemented at GEAE



# MANUFACTURING TECHNOLOGY FOR ENGINE ROTOR LIFE EXTENSION



B-74

Contract Number: TBD  
Prime Contractor/Location: TBD  
Start Date/Duration: Sep 01, 30/54 Mos.  
Program Manager: Jim Morgan, AFRL/MLMP

Funding(\$M)	FY01	FY02	FY03	FY04	FY05	TOTAL
AF ManTech	.200	2.50	5.00	5.00	2.30	15.0

## OBJECTIVES

Extend the operational lives of critical turbine engine components without increasing risk.

## APPROACH

Develop and implement an affordable prototype maintenance system that reduces overhaul time, cost, and extends the useful life of critical turbine engine components.

- Advance inspection techniques for internal & surface defects
- Component preparation processes
- Surface treatment measurement/credit for residual stresses
- Data management/prognostics
- Repair/Refurbishment processes

## DELIVERABLES

- Validated, Life management approach for turbine engines
- Prototype system implemented at OC-ALC

## CUSTOMER(s)

- ACC (primary) for F100, F101, F110, F119 engines

## BENEFITS

Achieve major reduction in engine component replacement costs: 50% reduction between FY2005-2010

- Reduce inspection time by ~50%
- Reduce the risk of catastrophic failures
- \$675M in potential savings in the 2005-2010 timeframe

## IMPLEMENTATION

- OC-ALC

## RELATED EFFORTS

- Multiple AFRL ERLE efforts (6.2, 6.3)



# QSP Challenges



- **Structural Weight Fraction: WEIGHT**
  - High specific stiffness/strength
  - Multifunctionality
  - Tailorability
- **M2.0 – 2.4**
  - High Temperature (~400- 600F )
  - Long term durability at temp
    - HSR data...
    - Insulating properties to prevent aero heating raising fuel temp
  - **Multi-material solutions/integration**
    - Fatigue resistance
    - Multifunctional
    - Bonding (outer skin smoothness)

B-75



# QSP Challenges



- **Design Practice Changes**
  - Full utilization/exploitation of materials (composites)
  - ‘ASIP’ philosophy
- **Manufacturing Issues**
- **Aeroelasticity Issues**
- **Probabilistic Design Requirements**

B-76



# Air Vehicle Directorate Structures Division



B-77



**David M. Pratt, Ph.D.**  
*Acting Technical Advisor*  
*Structures Division*

AFRL/VAS  
2130 Eighth Street, Suite 1  
WPAFB, OH 45433-7542  
Phone: (937)255-5752  
Fax: (937)656-7915  
email: [david.pratt@wpafb.af.mil](mailto:david.pratt@wpafb.af.mil)



# Structures Division Mission

AIR VEHICLES DIRECTORATE

Plans, directs, manages, and performs basic research, exploratory development, and advanced development in air vehicle

**structural design, structural technology integration, analytical structural mechanics, structural dynamics, sustainment, and extreme combined environment structures**

to solve critical structural problems on fixed-wing aerospace vehicles. Supports the Air Vehicles Directorate's integrating concepts of aircraft sustainment, uninhabited air vehicles, and future strike/space operating vehicles. Transitions technology results and products to major Air Force commands, other government organizations and industry through in-house and contracted efforts, consultation to System Program Offices, Air Logistics Centers, and other AFRL Directorates, and through participation in professional organizations. Provides technical advice and support to other DoD organizations and government agencies.



# Briefing (Dis)organization

AIR VEHICLES DIRECTORATE

## ■ Questions:

- ◆ How would a Mach number range (2.0-2.4) impact new requirements?
- ◆ How would you demonstrate using these materials and designs and what would be the maturity level required to do this?
- ◆ How would design practices need to change if current materials are used?
- ◆ What are the manufacturing issues?
- ◆ What are the aeroelasticity issues for this type of vehicle?
- ◆ What is needed to do a probabilistic design criteria approach?

## ■ Issues – VAS slant

- ◆ Embedded engine & aft decks
- ◆ Light weight structures
- ◆ Design/analysis – probabilistic methods
- ◆ Aeroelasticity
- ◆ Mission adaptable structure

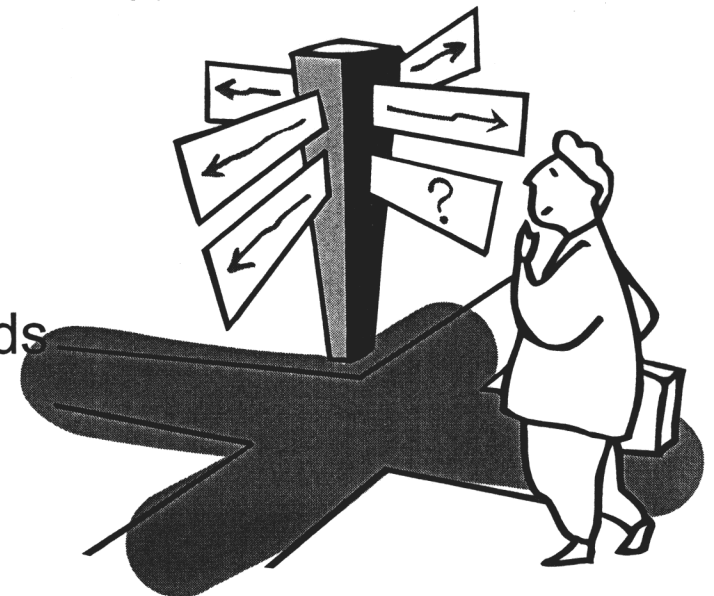

13-79



# Embedded engine & aft decks

B-86



# EXHAUST WASHED THERMAL STRUCTURES

AIR VEHICLES DIRECTORATE

## DESCRIPTION

Develop and Demonstrate Structurally Integrated Nozzles & Exhaust Washed Structures capable of operating in extreme environments

## TECHNICAL CHALLENGES

- Durability in thermoacoustic environment
- Structurally integrated airframe nozzles
- Concept fabricability
- Supportability/Maintainability

## RELEVANCE

- Reduce Structural Manufacturing Costs
- Reduce Structural O&S Costs
- Reduce Structural Weight

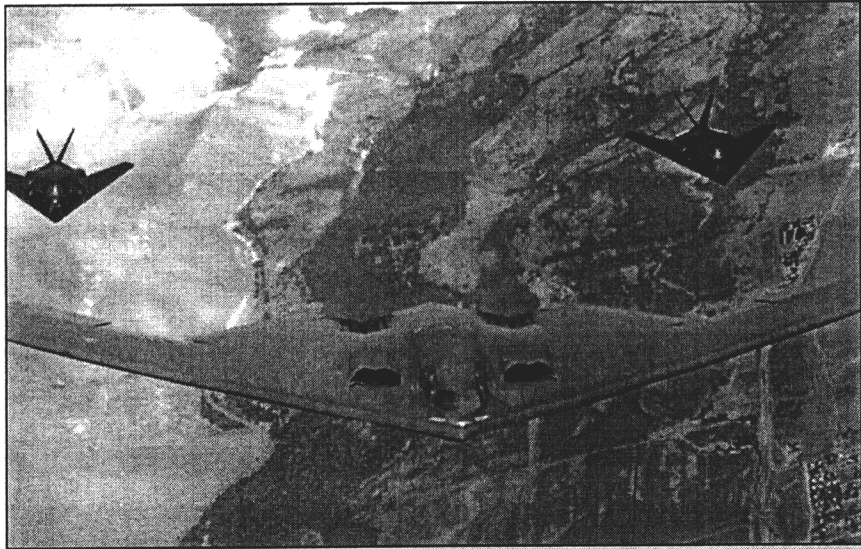

13-81



# EXHAUST WASHED THERMAL STRUCTURES

AIR VEHICLES DIRECTORATE

## EXHAUST WASHED STRUCTURES

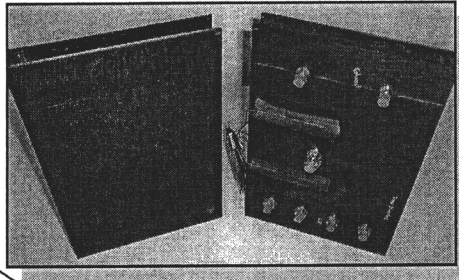

Develop, Fabricate and Test Highly Survivable Structurally Integrated Exhaust System Designs

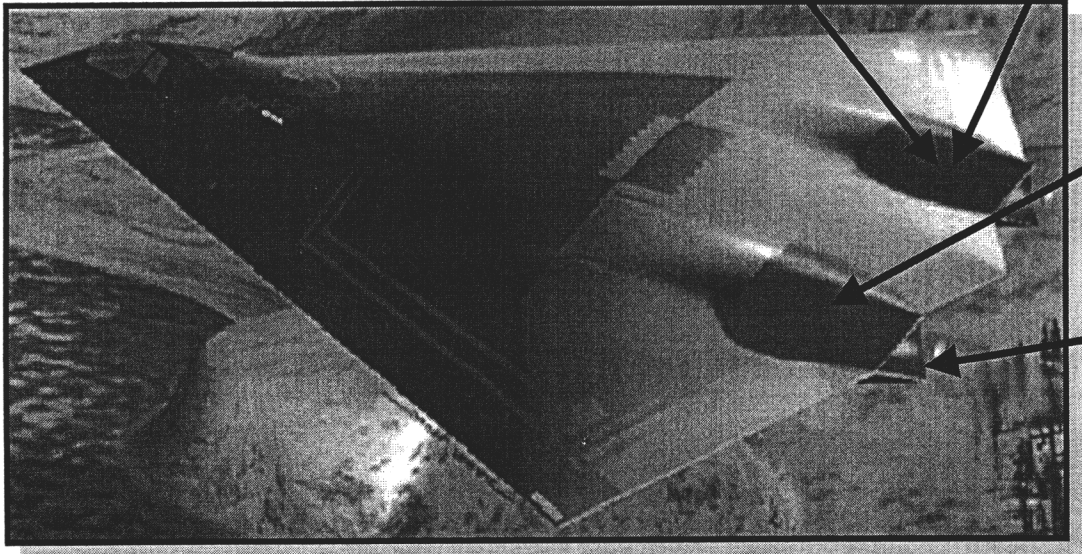
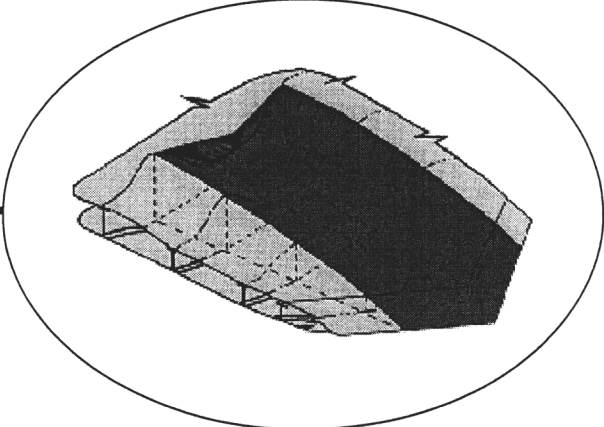
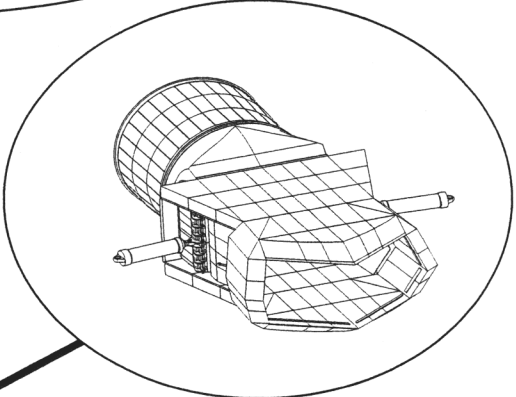

B-82



AIR VEHICLES DIRECTORATE

# CASRL

B-83



# FACILITIES

AIR VEHICLES DIRECTORATE

## CEAC

- 174 dB OASPL
- 50-500 Hz Flat Spectrum
- 50 Btu/ ft<sup>2</sup>-sec
- 4'x10' Acoustic only
- 4'x4' Combined Thermal/Acoustic

## SEF

- 174 dB OASPL
- 50-500 Hz Flat Spectrum
- 70 Btu/ ft<sup>2</sup>-sec
- 12"x18" Combined Thermal/Acoustic

## Combined Environment

- Variable Test Configurations
- Computer Controlled

### Mechanical Load

### Radiant Heating

Quartz Lamps – 114 W/cm<sup>2</sup> (100 BTU/FT<sup>2</sup>S)

Graphite Heaters – 340 W/cm<sup>2</sup> ( 300 BTU/FT<sup>2</sup>S)

Vortek Arc Lamp – 2270 W/cm<sup>2</sup>

(2000 BTU/FT<sup>2</sup>S)(Small Area)

**Active Cooling** (Gases - Nitrogen, Hydrogen, Helium, Argon, Air; Liquids - Water, Ethylene Glycol, JP-7, JP-8 Fuel, Nitrogen\_

B-84

## FUTURE CAPABILITIES

- 174 dB OASPL
- 50-500 Hz Flat Spectrum
- 70 Btu/ ft<sup>2</sup>-sec
- 10'x10' Combined Thermal/ Acoustic/ Mechanical



# Consolidated Aerospace Structures Research Laboratory (CASRL)

AIR VEHICLES DIRECTORATE

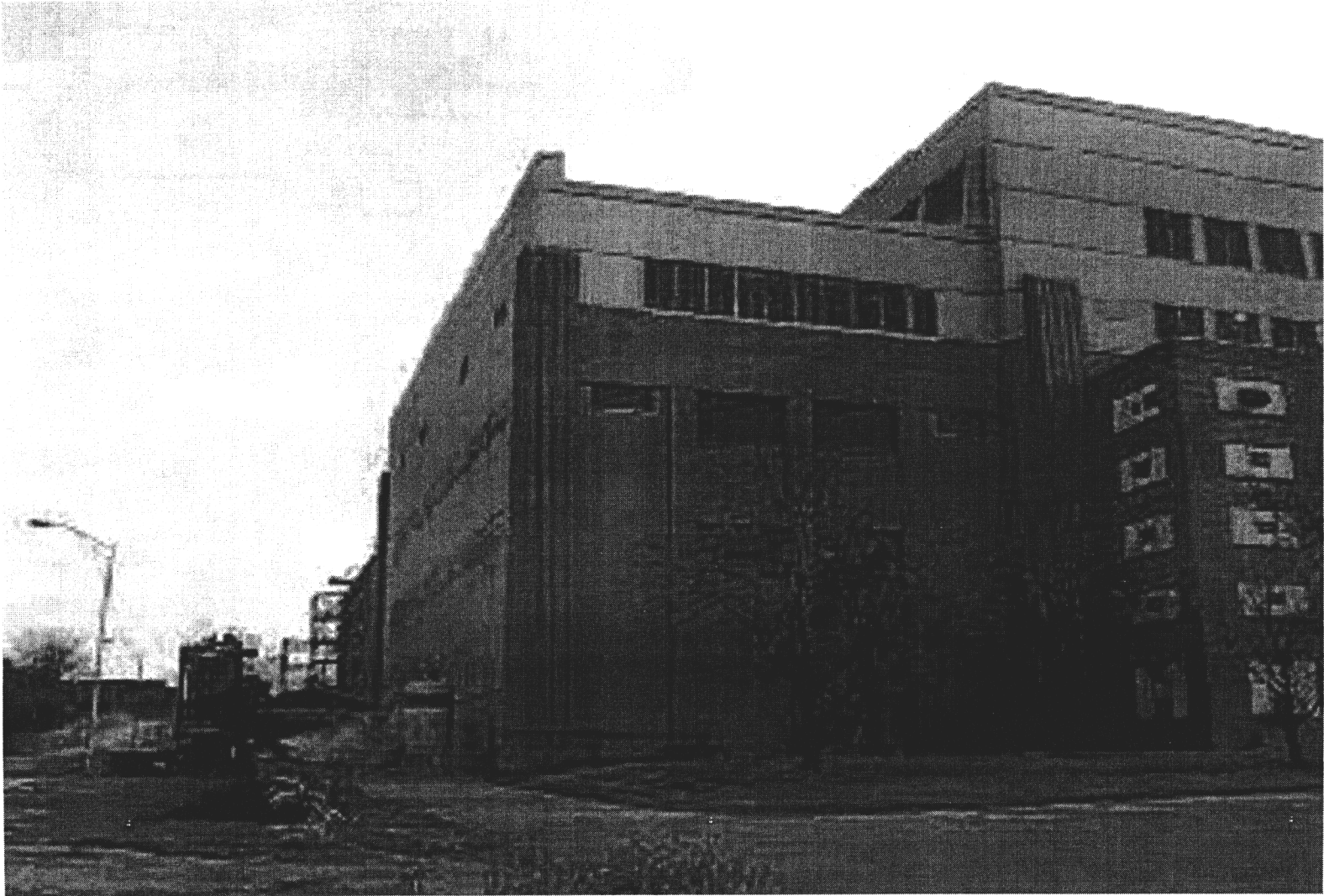

13-85



AIR VEHICLES DIRECTORATE

# Light weight structures

13-86



# Advanced Lightweight Aircraft Structures Program

AIR VEHICLES DIRECTORATE

Sponsored By Joint Advanced Strike  
Technology (JAST) 1995-1998

Study Program to Demonstrate  
Cost/Weight Benefits Achievable Through  
Unitization

**ALAFS BASELINE**

***F/A - 18 E/F Center  
Fuselage and Wing***

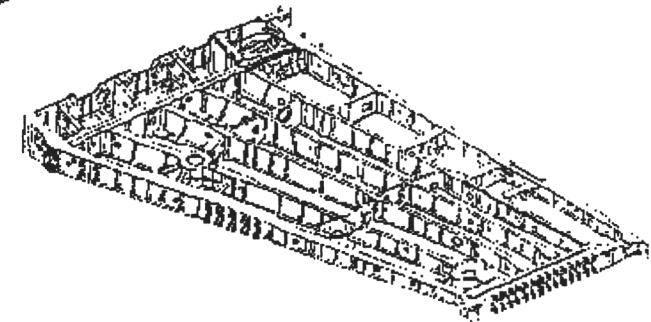
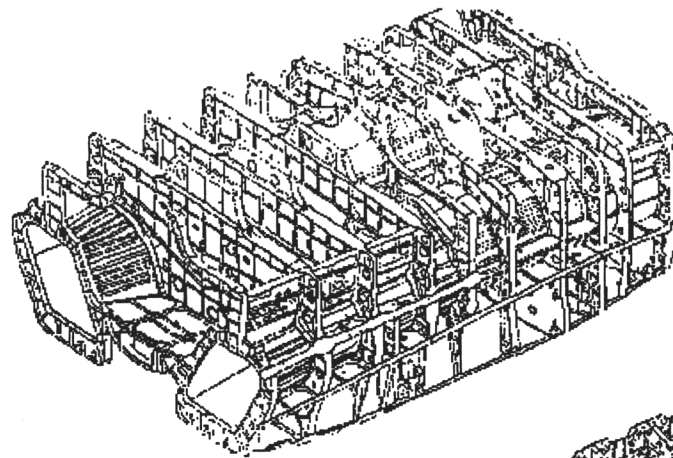

Early Focus of Program was on Greater  
Application of Advanced Composites

As design matured emphasis on metals  
was increased

B-87



# ALAFS Preferred Structural Concept

AIR VEHICLES DIRECTORATE

13-88

RTM Spars CoBonded to a 1-Piece, Fiber Steered, Lower Wing Skin (\$,#)

RTM Spars Contain Hybrid Laminates for Survivability and 3D Preforms for Out of Plane Loads (#,\$)

Structural Arrangement Optimization (#,\$)

Unitized, Syntactic Core Sandwich Inlet Ducts and OML Skins (\$,#)

Unitized Dorsal Assy, Cocured Skins and Substructure (\$,#)

Titanium HIP Cast Pylon Support Fittings (\$)

C-Section, RTM Fuselage Frames With 3D Preforms (\$,#)

EB Welded, Titanium HIP Cast MLG Support Bulkheads (\$)

- RTM Composites
- Fiber Placed/Steered
- HSM Aluminum
- Titanium HIP Casting
- Aluminum Sh Metal
- Titanium Machining

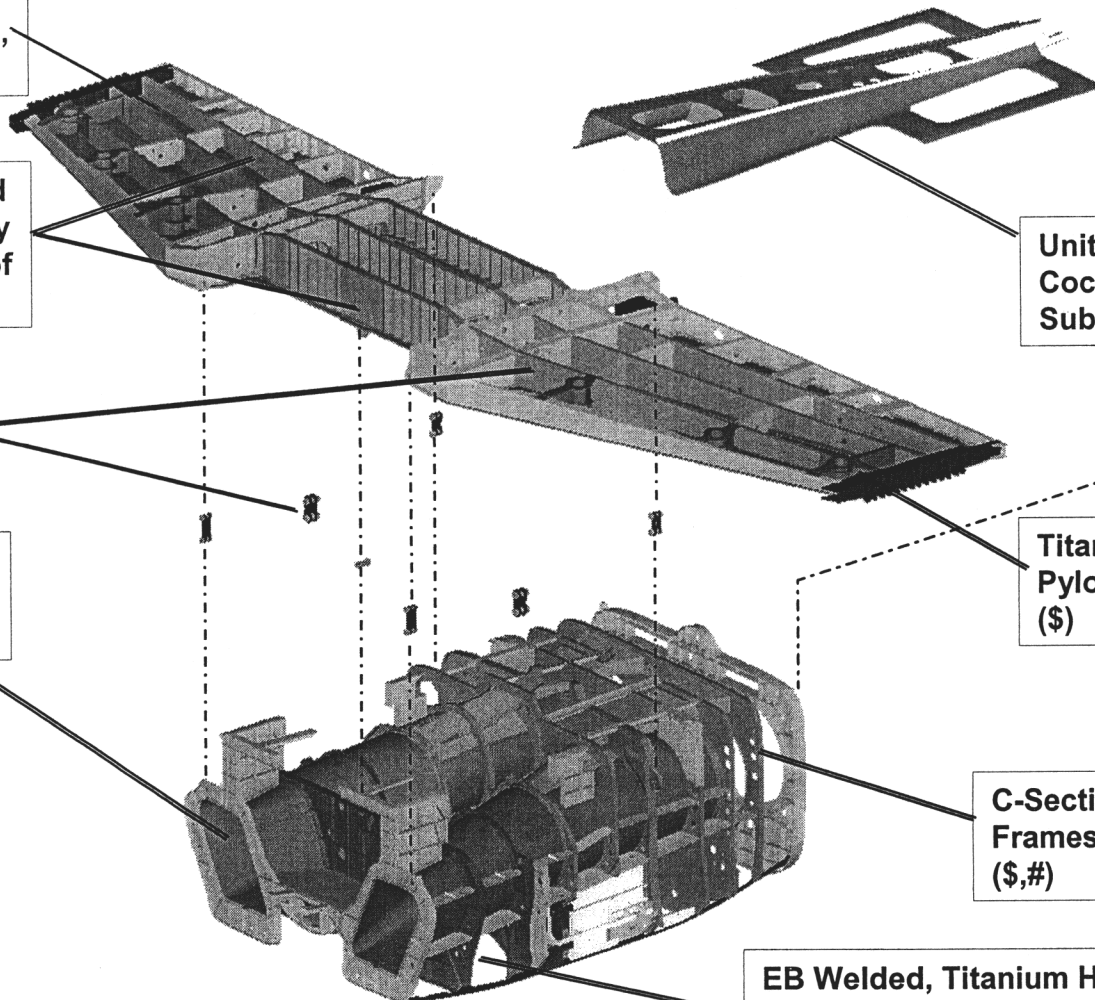



# ALAFS Risk Technology - Alternatives

AIR VEHICLES DIRECTORATE

Technology	Fallback Design	Cost Impact*	Weight Impact*
Syncore Sandwich	Monolithic skins	\$ 50,000	77
Postbuckled C/E	Increased thickness in composites	\$ 15,000	49
Fiber Placement & Steering	Hand collation	\$ 100,000	0
HIP Casting	Increased part & fastener count. Assume HIP Cast bulkheads could be replaced with Ti forgings at equivalent weight. Deletion of HIP Castings would prevent MLG Sidebrace Integration to Y491 BH (+47 lb ftg/assy, -8 bulkhead).	\$ 150,000	39
Ti Weldments	Machined forgings	\$ 150,000	0
Hybrid Laminates	Bolted aluminum spars, increased ballistic foam. Deleting glass from the laminate would increase the stiffness enabling the duct to have a reduced thickness. In addition, deletion of the glass will lower the density of the laminate.	\$ 30,000	57
3-D Inserts	Bolted metal fittings/parts	\$ 10,000	19
RTM	Bolted metal parts, Ti spars	\$ 25,000	150
C/E Unitization	Increased part & fastener count	\$ 20,000	13
Cobonding	Increased part & fastener count, mechanical fastening	\$ 20,000	5
Integrated Dimensional Mgmt	Rework on assembly, more shimming	\$ 50,000	10

B-89

<b><u>“TOTAL FAILURE” GIVES BACK</u></b>	<b><u>\$620K</u></b>	<b><u>419#</u></b>
<b><u>ALAFS DESIGN BENEFITS</u></b>	<b><u>\$1137K</u></b>	<b><u>924#</u></b>



# Composites Affordability Initiative

AIR VEHICLES DIRECTORATE

B-90

**Today**

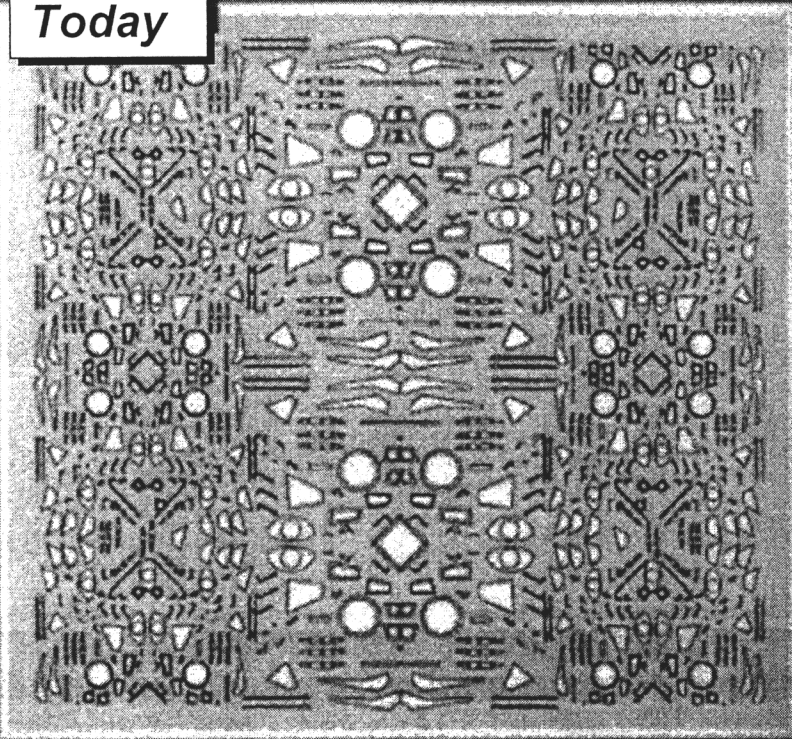

- 11,000 Metal Components
- 600 Composite Components
- 135,000 Fasteners

**Design For Affordability**

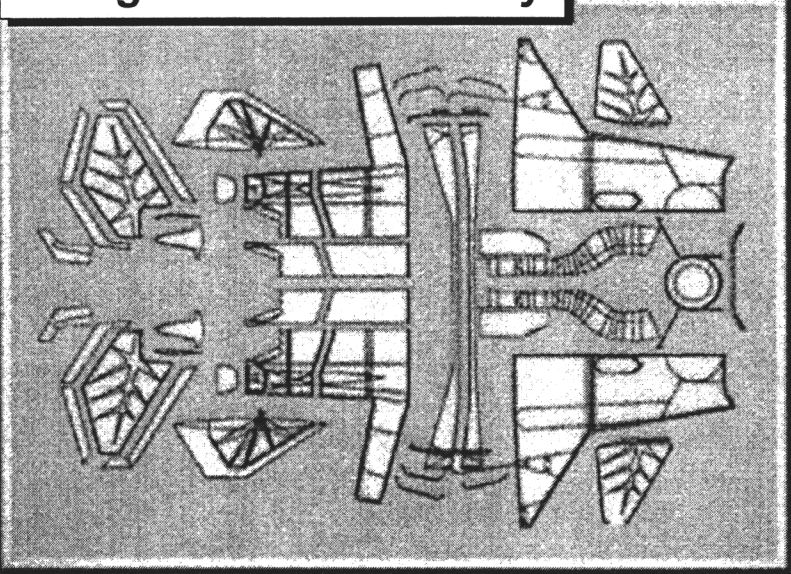

- 450 Metal Components
- 200 Composite Components
- 6,000 Fasteners

- *Reduce Part Count*
- *Improve Producibility*
- *Dramatically Reduce Assembly Costs*





# Ultra light weight structures program

AIR VEHICLES DIRECTORATE

Paradigm shift – there are NO boundaries between structural design, manufacturing technologies and materials

- Optimization of materials
- Bio-inspired concepts
- Reliability based design



AIR VEHICLES DIRECTORATE

# Design/analysis - probabilistic methods

B-92



# Design practice

AIR VEHICLES DIRECTORATE

## TODAY

- AML (Adaptive Modeling Language) – Engineering Framework for Collaborative Design
- ASTROS (Automated Structural Optimization System) – Preliminary design
- MDICE (Multi-Disciplinary Computing Environment) – Engineering Framework for High Fidelity Aero-Structures

## REQUIRED

- AML
  - Higher Fidelity Interactions
  - Cost Models
  - Web Based Design
- ASTROS
  - Higher Fidelity Aero Codes
  - Commercialization
- MDICE
  - Additional Aero Codes
  - Controls & Thermo Module
  - Reduced Order Models

B-93



# Probabilistic Methods

AIR VEHICLES DIRECTORATE

B-94

- TODAY
- Reliability based design
    - ◆ Estimates
    - ◆ Low fidelity
  - Probabilistic/uncertainty
    - ◆ Huge
    - ◆ 3D
    - ◆ Use of Monte Carlo
    - ◆ Impact of prob dist for aero response of panels
    - LCO

- REQUIRED
- Reliability based design of aeroelastic systems
    - ◆ Identification of reliability metrics and parameter
    - ◆ EX: Tips deflection
      - ◆ Failure criteria - not to exceed
      - ◆ Sensitive parameters
        - ➔ Likelihood of failure
  - Probabilistic/uncertainty
    - Stochastic FEM – Mid Fidelity
    - Fluid/structure interaction



AIR VEHICLES DIRECTORATE

**MDT**

B-95



# Multi-Disciplinary Technologies Center

AIR VEHICLES DIRECTORATE

**Objective:** Lead the development and innovation multidisciplinary design and analysis technologies, methodologies and processes that enable revolutionary aerospace vehicle capabilities for the warfighter

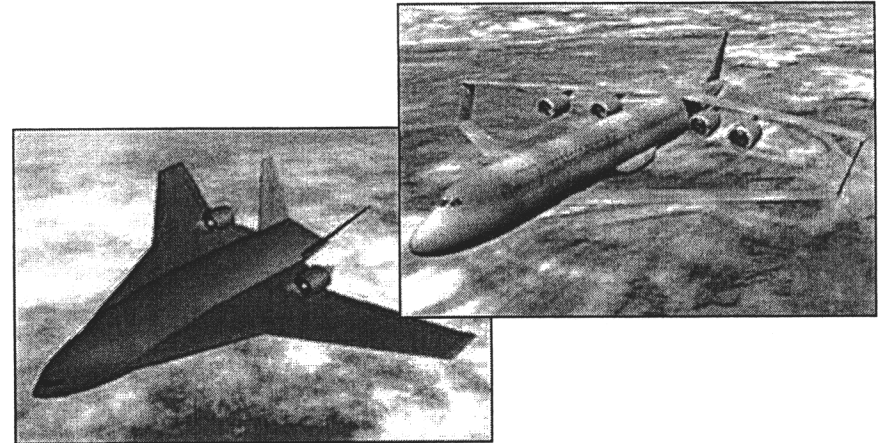

## Areas of expertise:

- Multidisciplinary methods for design and analysis
- **Design processes**
- **Uncertainty analysis**
- **Innovative A/V concepts**
- **Reduced order modeling**
- Cost modeling
- **Optimization**

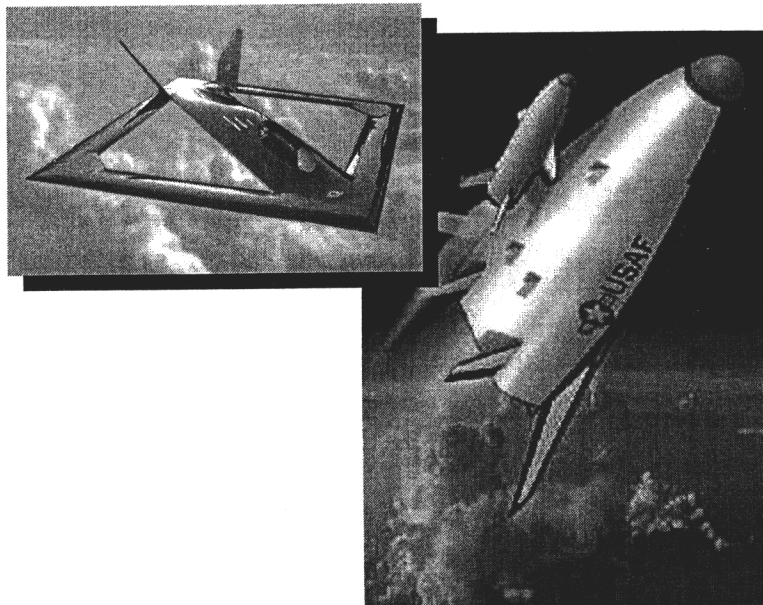



AIR VEHICLES DIRECTORATE

# Aeroelasticity

B-97



# Aeroelasticity

AIR VEHICLES DIRECTORATE

- Aeroelasticity issues, but no show stoppers if the stiffness is adequate
- Instabilities → Active control
  
- Need to assess
  - ◆ Aeroelastic tailoring – passive
  - ◆ Active controls
  - ◆ Adaptive structures – AAW, HiLDA, ...



AIR VEHICLES DIRECTORATE

# Mission adaptable structures

B-99



# Active Aeroelastic Wing

AIR VEHICLES DIRECTORATE

**Active Aeroelastic Wing (AAW) is a multidisciplinary, synergistic technology that integrates air vehicle aerodynamics, active controls, and structures**

- ◆ **Turns wing aeroelastic flexibility into a net benefit**
- ◆ **At high dynamic pressures, AAW control surfaces are used as "tabs" that promote wing twist for added control force capability instead of trying to overcome control surface losses due to wing elastic twist.**

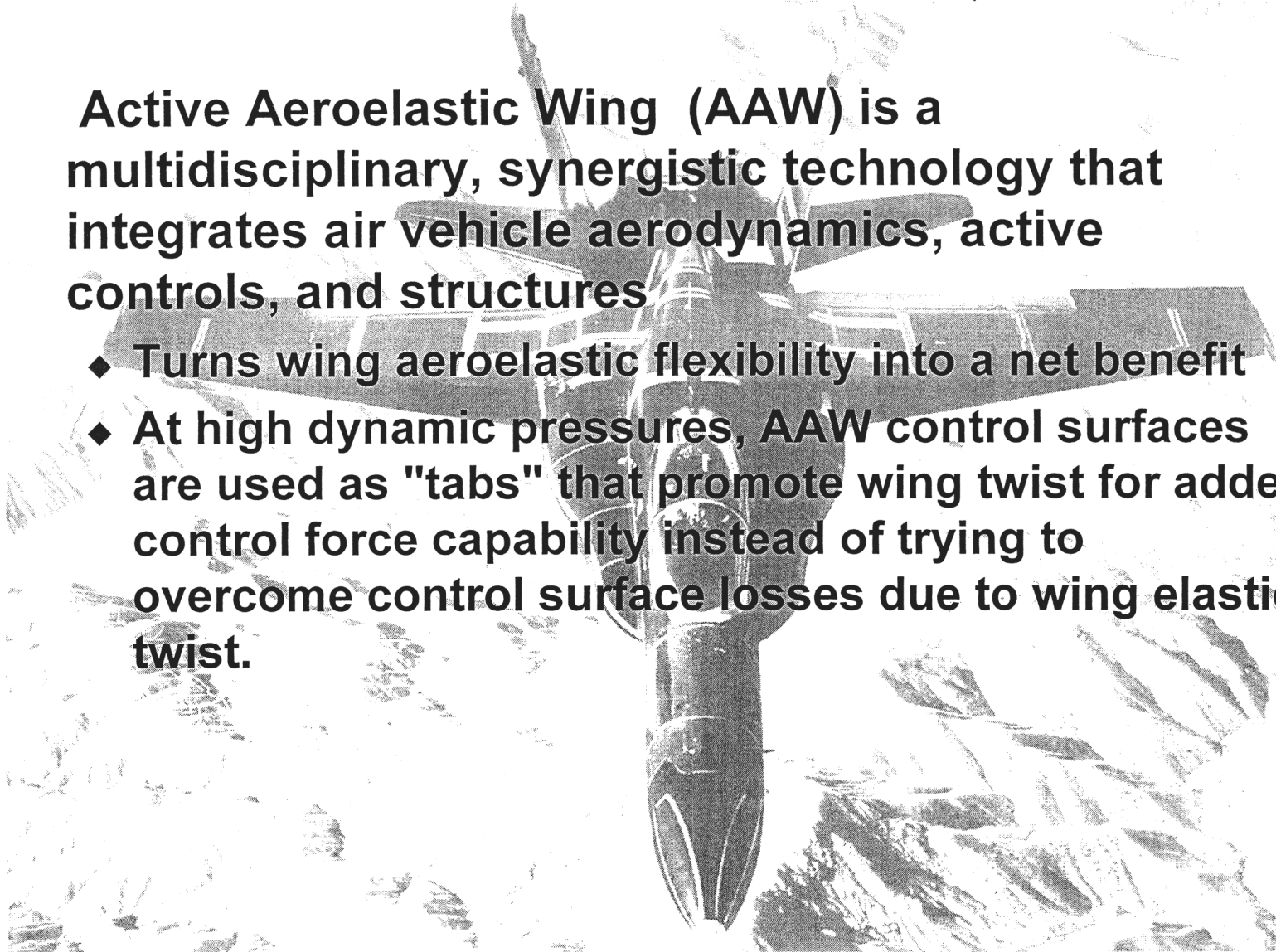



# High L/D Active (HiLDA) Wing

AIR VEHICLES DIRECTORATE

- Apply AAW, adaptive structures and active flow control to a Sensorcraft wing design for load reduction and improved L/D.

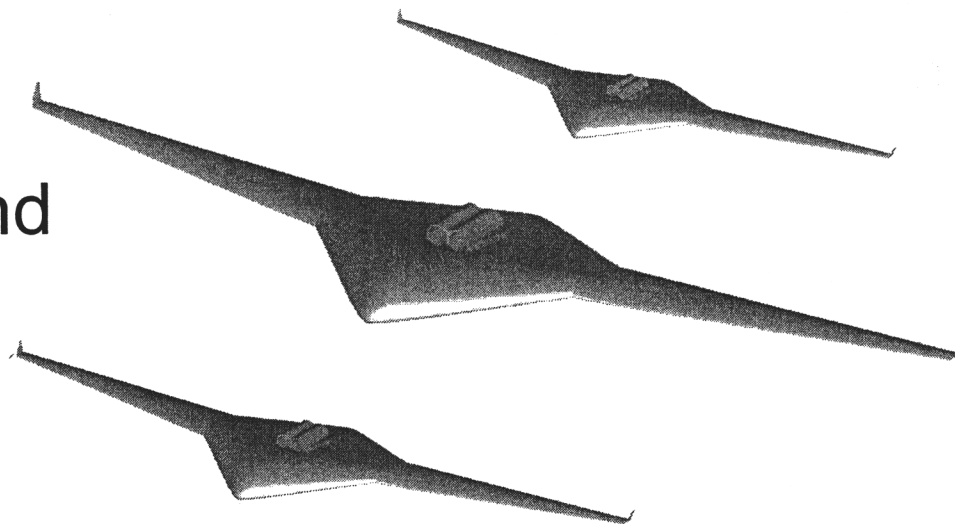
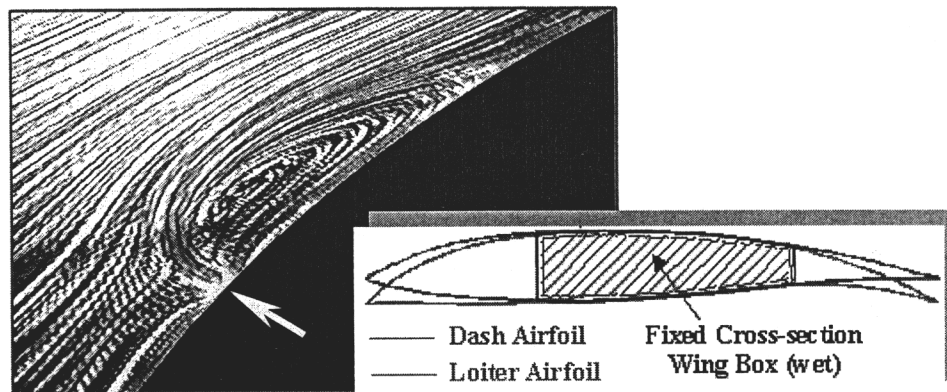

B-101



# Adaptive structures

AIR VEHICLES DIRECTORATE

- Some additional ideas
  - ◆ Leading edge
  - ◆ Inlets
  
- Adaptive structures- Maj Brian Sanders

13-102



B-103

# Backups



# COMBINED ENVIRONMENT EXPERIMENTAL CAPABILITIES

AIR VEHICLES DIRECTORATE

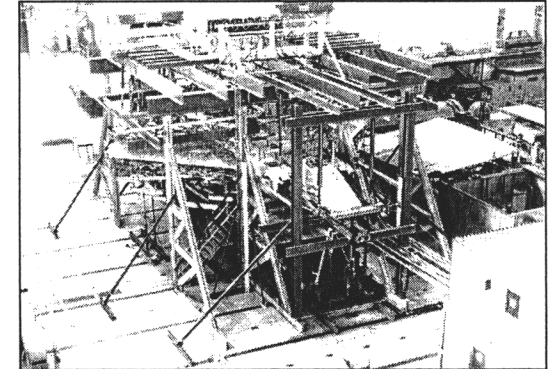

## EXPERIMENTAL CAPABILITIES

Variable Test Configurations

Computer Controlled

Mechanical Load

Radiant Heating

Quartz Lamps –  $114 \text{ W/cm}^2$  (100 BTU/FT<sup>2</sup>S)

Graphite Heaters –  $340 \text{ W/cm}^2$  (300 BTU/FT<sup>2</sup>S)

Vortek Arc Lamp –  $2270 \text{ W/cm}^2$

(2000 BTU/FT<sup>2</sup>S)(Small Area)

Active Cooling

Gases - Nitrogen, Hydrogen

Helium, Argon, Air

Liquids - Water, Ethylene Glycol

JP-7, JP-8 Fuel, Nitrogen

Data Acquisition

512 Data Channels Per Test

Real Time Data Processing and Display

Instrumentation

Room and Elevated Temperature Strain

Temperature, Mechanical Load, Flow

Pressure, Deflection

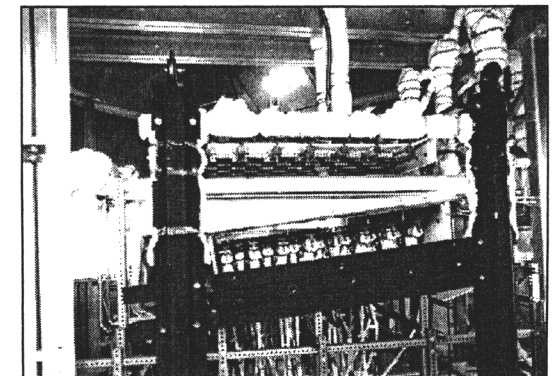
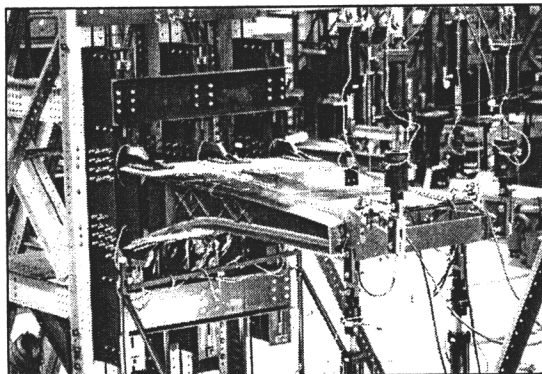

B-104



# THERMAL/ACOUSTIC FACILITIES

AIR VEHICLES DIRECTORATE

## CAPABILITIES

### CEAC

- 174 dB OASPL
- 50-500 Hz Flat Spectrum
- 50 Btu/ ft<sup>2</sup>-sec
- 4'x10' Acoustic Only
- 4'x4' Combined Thermal/Acoustic

### SEF

- 174 dB OASPL
- 50-500 Hz Flat Spectrum
- 70 Btu/ ft<sup>2</sup>-sec
- 12"x18" Combined Thermal/Acoustic

## FUTURE CAPABILITIES

- 174 dB OASPL
- 50-500 Hz Flat Spectrum
- 70 Btu/ ft<sup>2</sup>-sec
- 10'x10' Combined Thermal/Acoustic/Mechanical

B-105

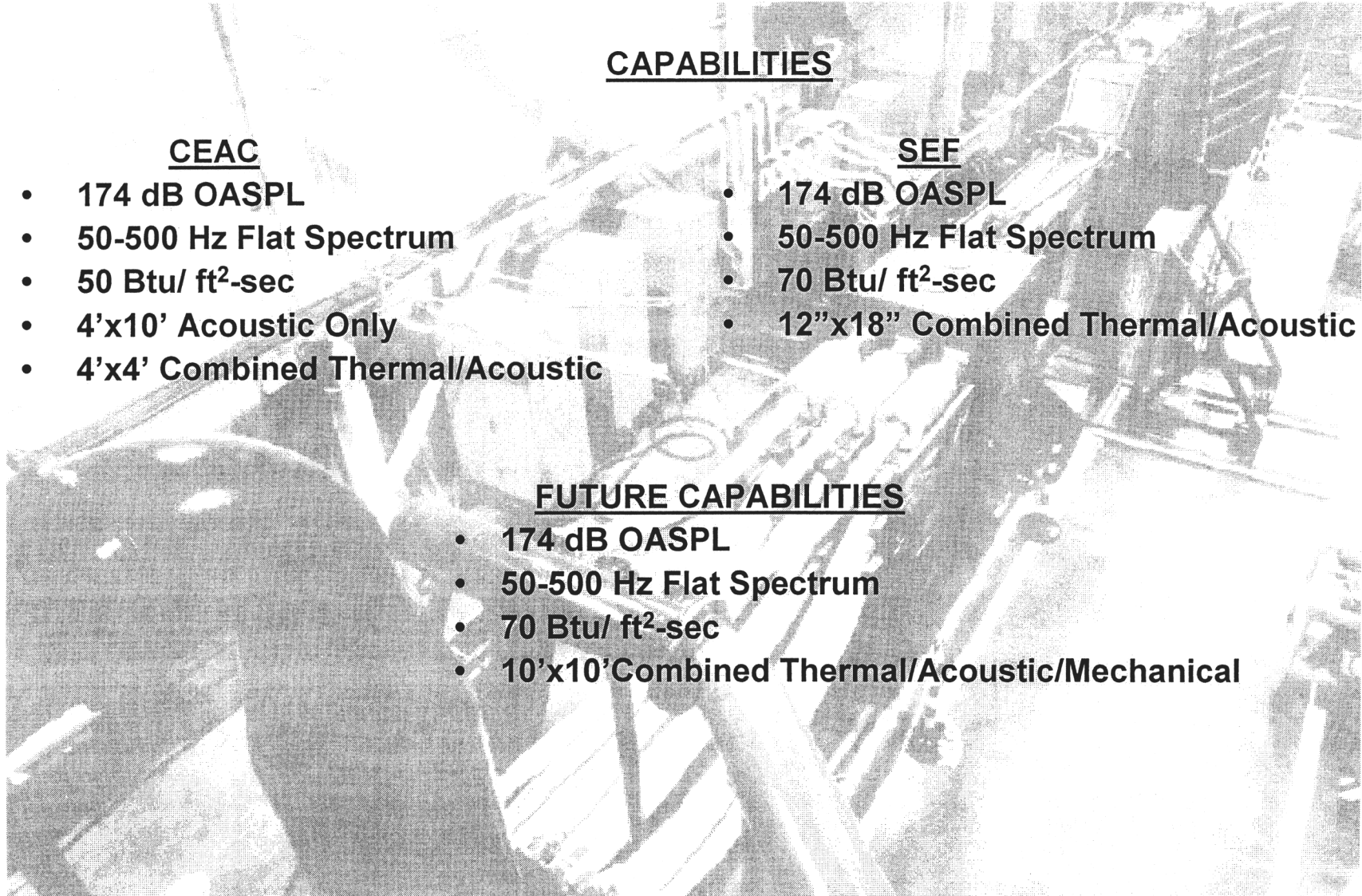



# AML Importance

AIR VEHICLES DIRECTORATE

- AML provides an object oriented engineering framework to capture and organize the vital engineering knowledge and processes within a unified object-oriented part model.
- AML's underlying virtual layer architecture enables the seamless integration of engineering tools to automate the entire engineering cycle from conceptual design to production.
- WDE creates a distributed network of designers working on the same analysis model concurrently



# ASTROS

AIR VEHICLES DIRECTORATE



OUR FUTURE  
OUTPUT

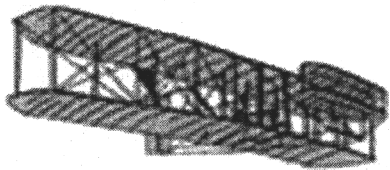
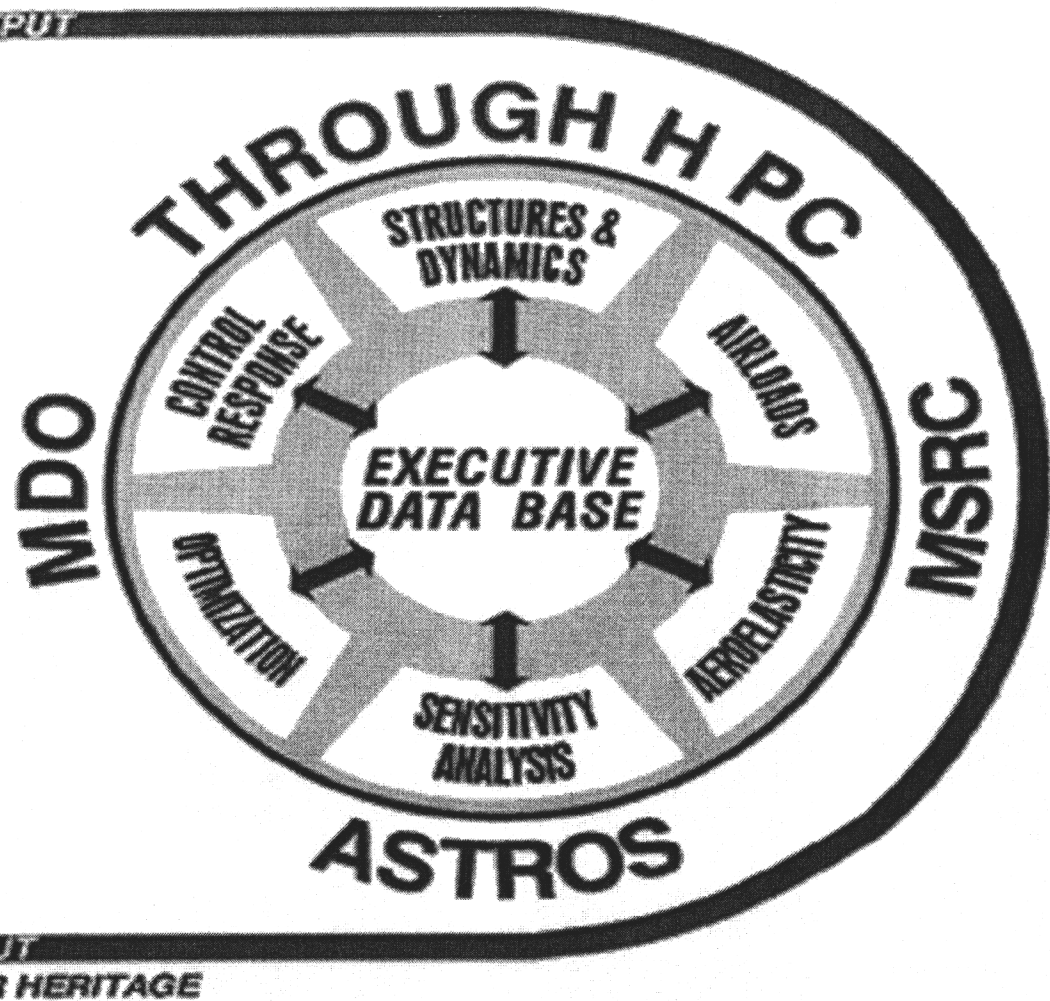

INPUT  
OUR HERITAGE

B-107



# MDICE CONCEPTUAL OVERVIEW

AIR VEHICLES DIRECTORATE

MDICE enables engineering programs of various disciplines and sources to function as ONE coupled multi-disciplinary application in a parallel distributed computing environment

13-108

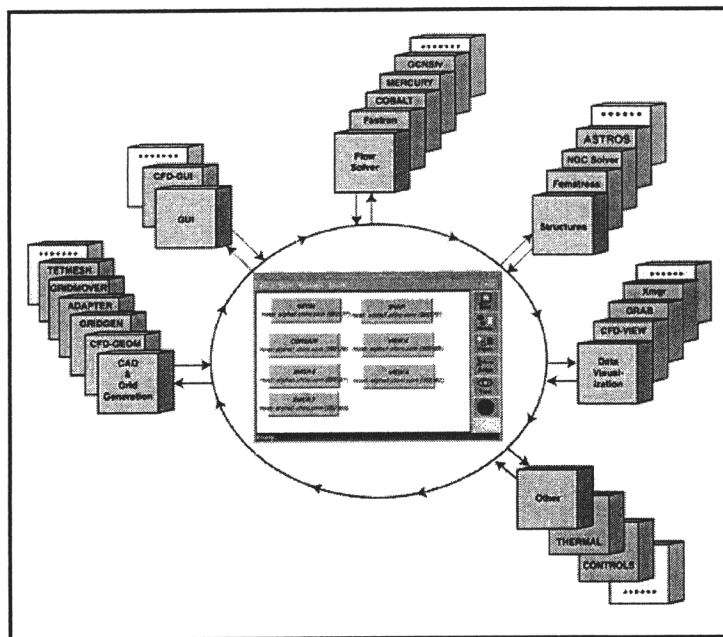

**MDICE  
Multi-Disciplinary  
Computing Environment**

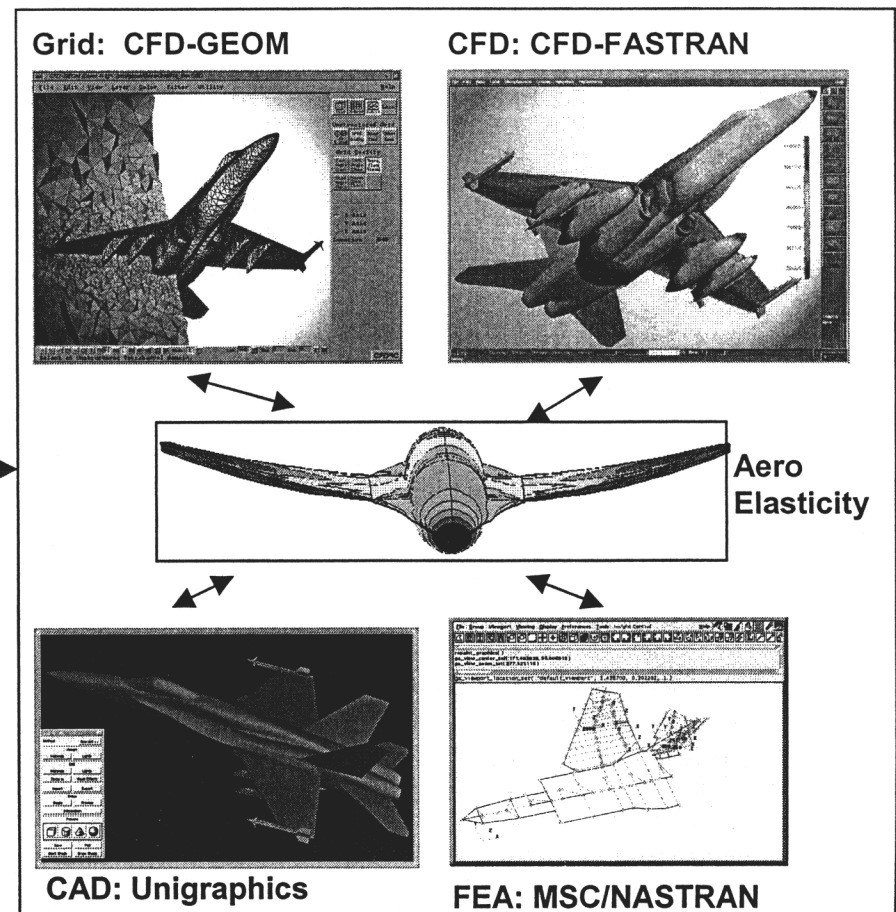

MDICE Application Example: Fluid-Structure Interaction

**BRIAN SANDERS  
AFRL/VASD**

**ADAPTIVE STRUCTURES**

B-109



# Conformal Control Surfaces Smart Wing Program

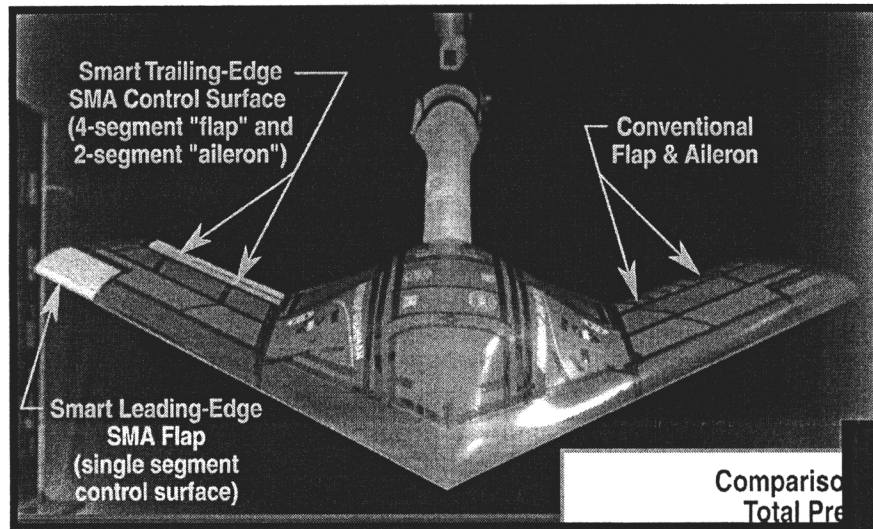

Northrop Grumman

B-110

Conformal control surfaces  
may relieve some thermal  
management issues

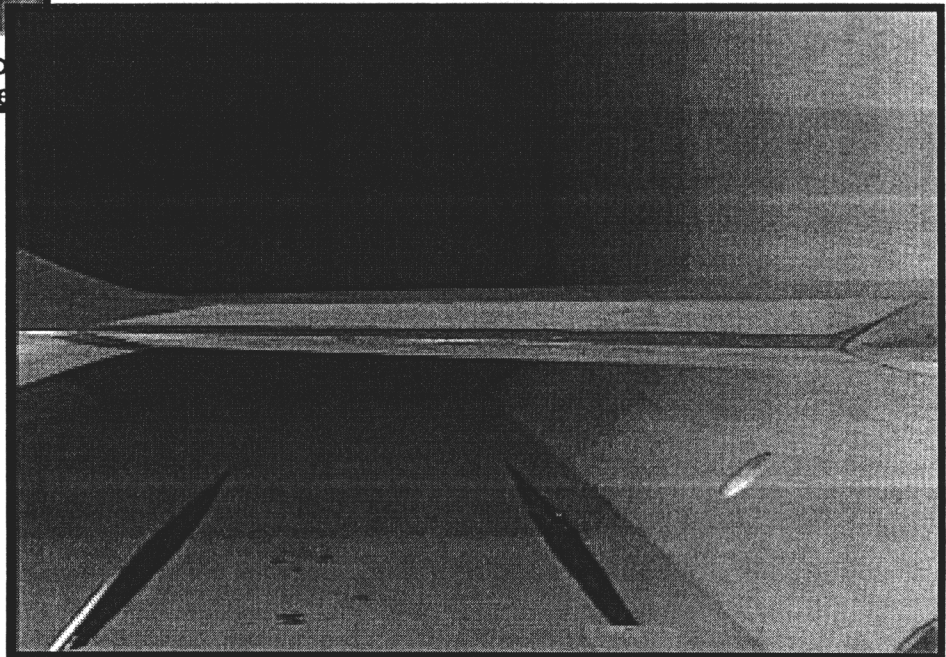



# Variable Geometry Inlets DARPA SAMPSON Program



Boeing

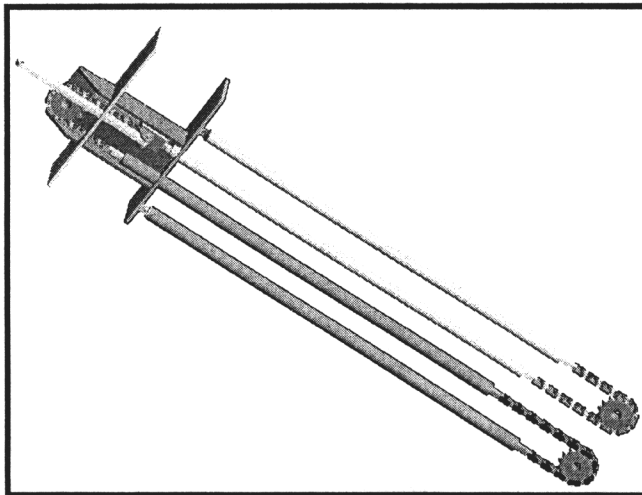

B-111

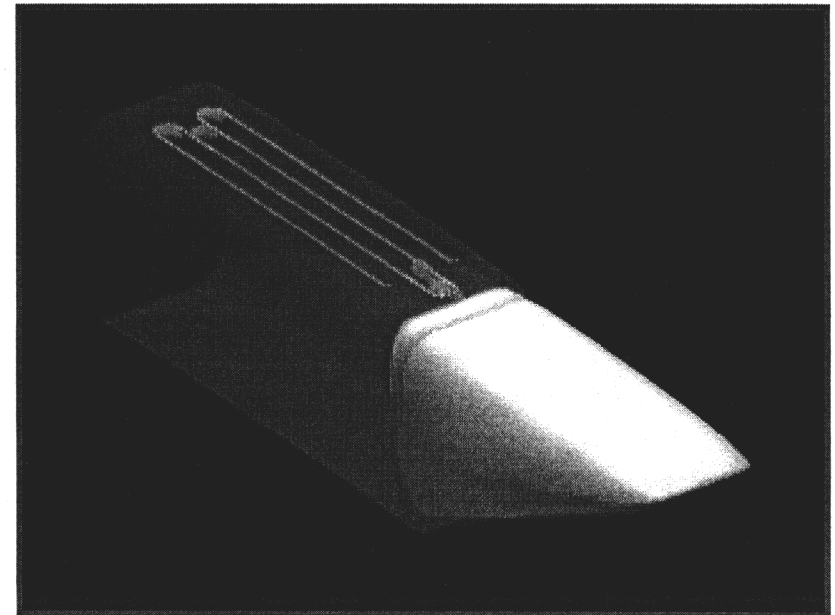
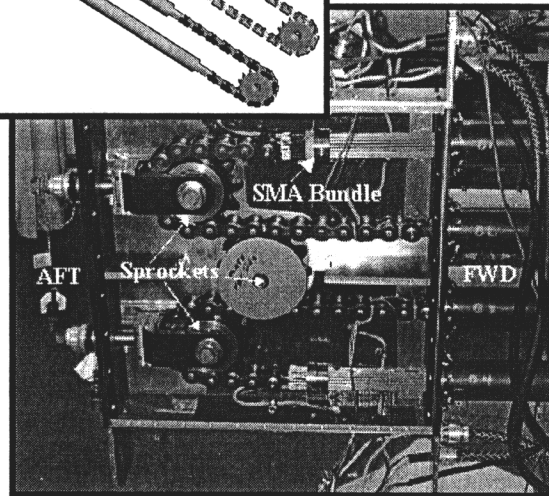

Variable geometry inlets  
are most useful at  
supersonic speeds



# Energy Harvesting



B-112

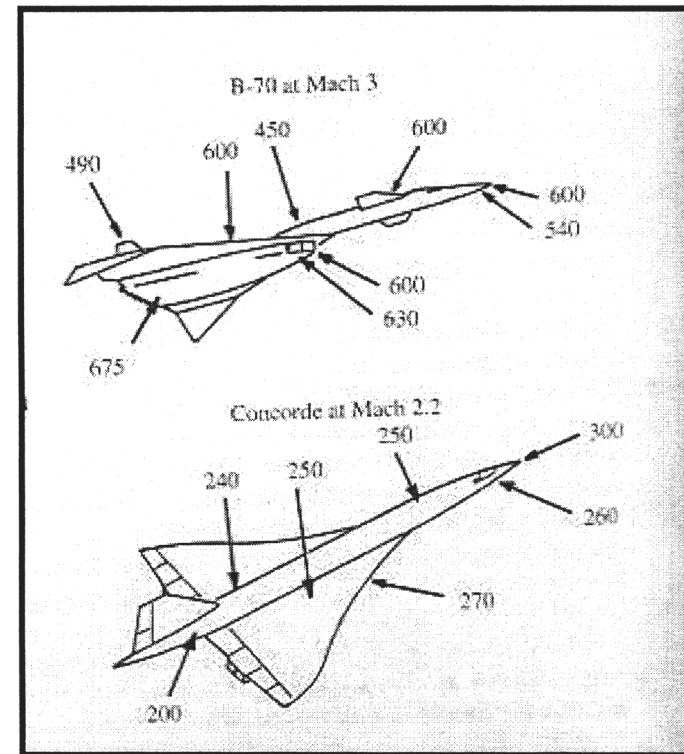
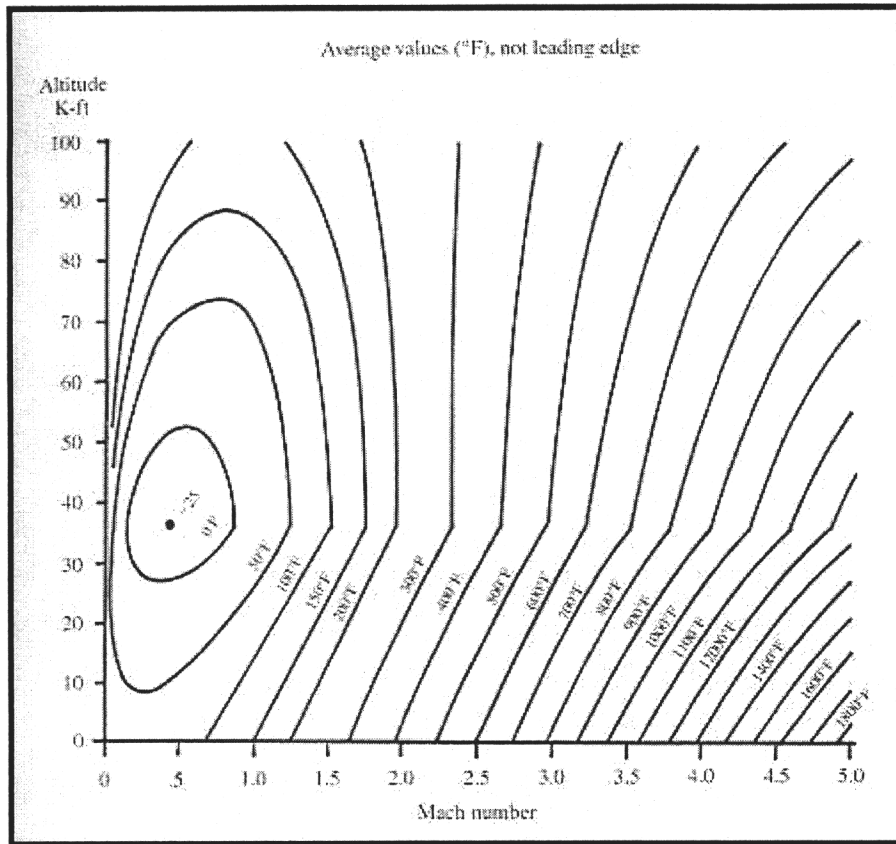

Supersonic Skin Temperatures

Approximate Skin Temperatures

Can existing thermal energy be used to drive actuation systems (e.g. SMAs)

# Structures and Materials Technologies for High Speed Flight Vehicles

Dennis L. Dicus & Michael P. Nemeth  
Structures & Materials  
NASA Langley Research Center

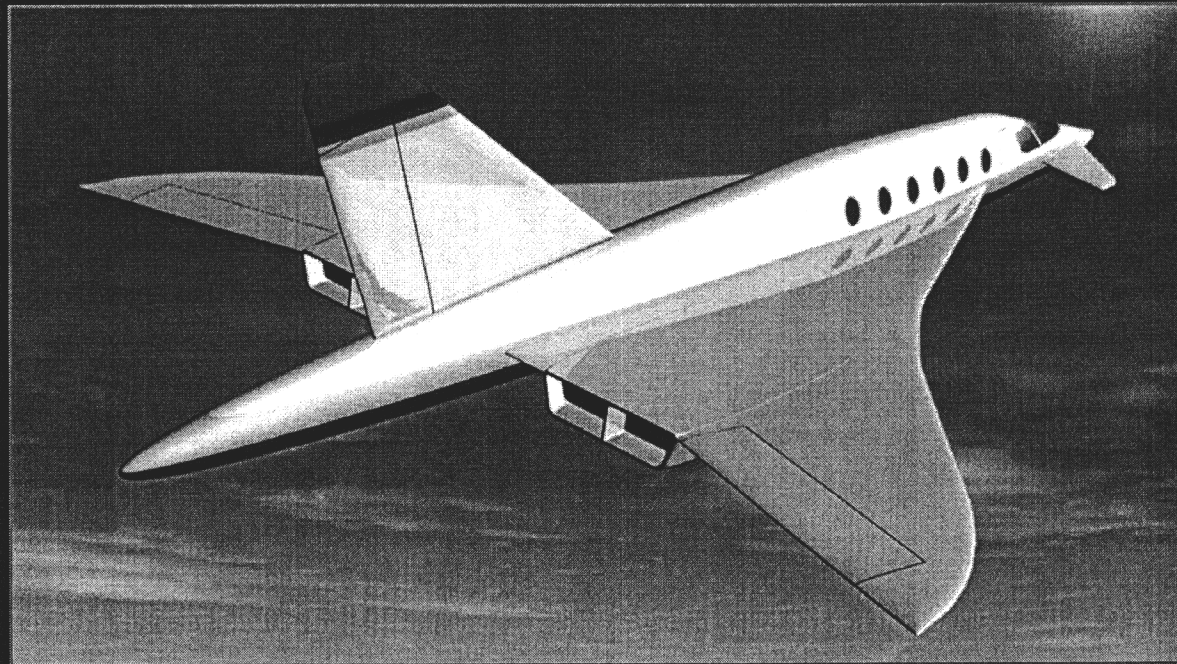

DARPA QSP Focus Group Meeting on  
Structures & Materials and Structures  
June 26, 2001

# Structures and Materials Technologies for High-Speed Flight Vehicles

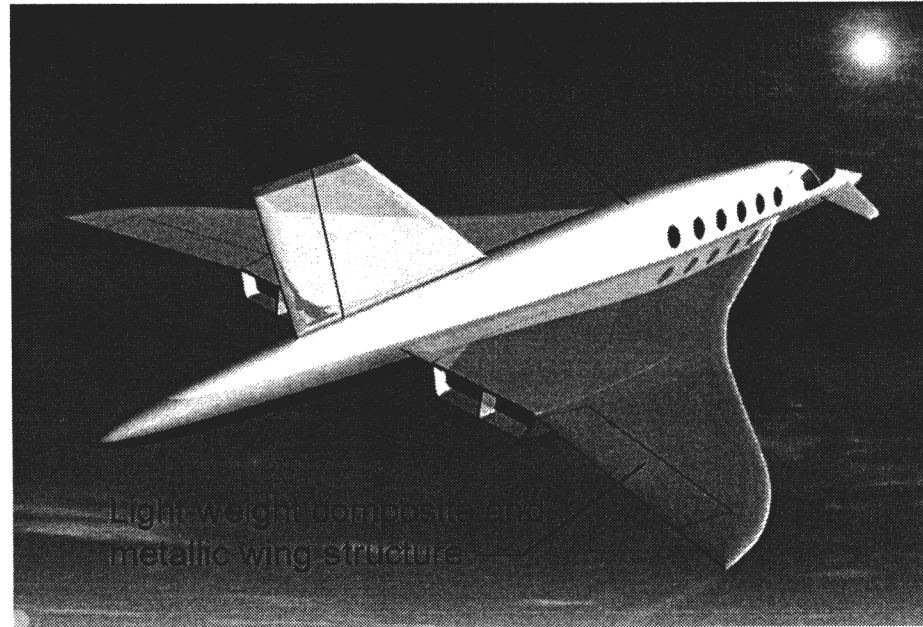

13-114

- **Advanced composite materials and processing**
- **Advanced elevated-temperature aluminum alloys and processing**
- **Lightweight wing and fuselage structures**
- **Advanced structural analysis and design technologies**

# Weight Reduction Required for HSCT

B-115

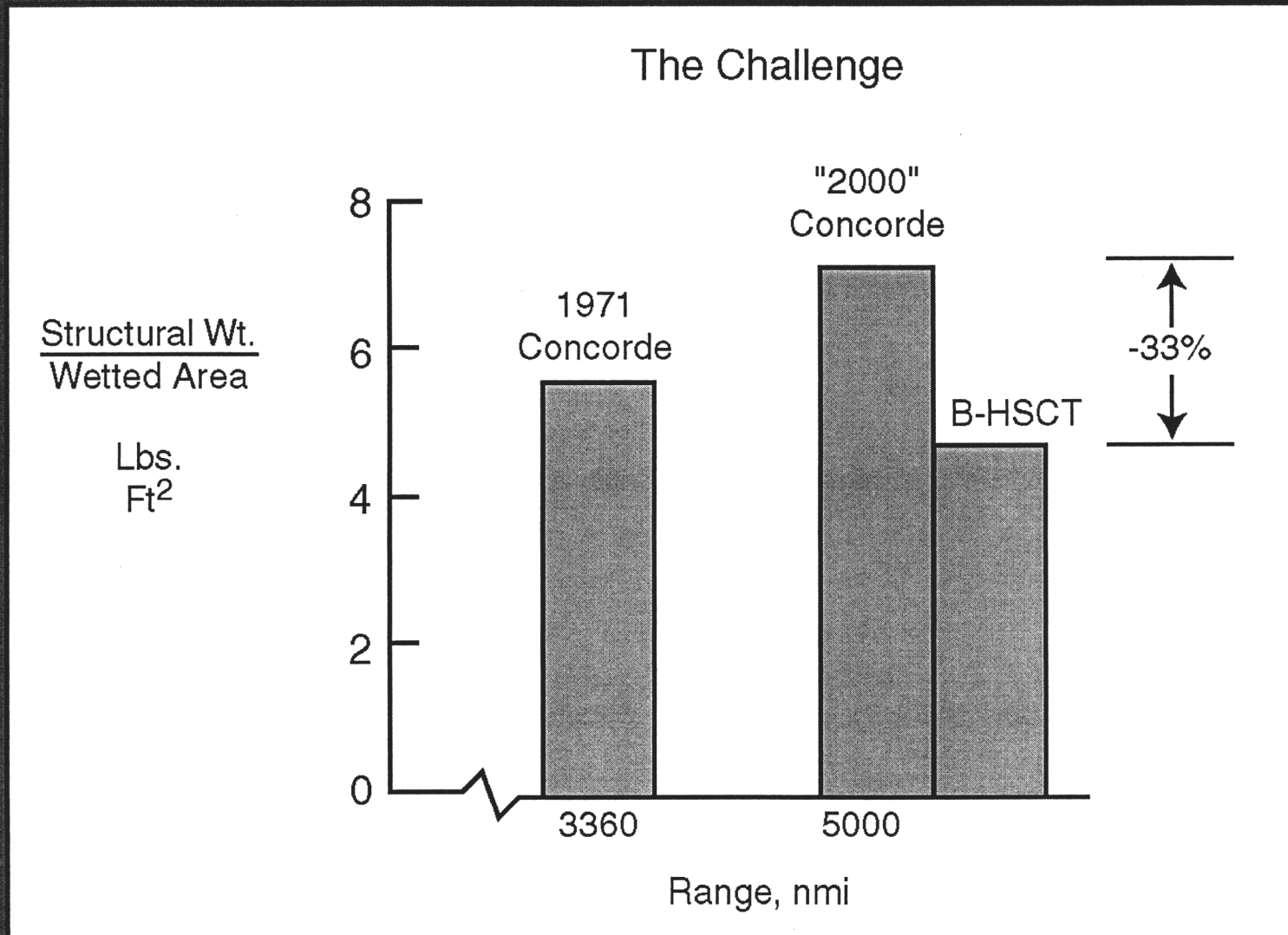

# HSR AIRFRAME MATERIALS TECHNOLOGY

## Key Issue

No long-term, high-temperature materials data base for HSCT airframes (60,000-hr design life, 120,000-hr fatigue life)

B-116

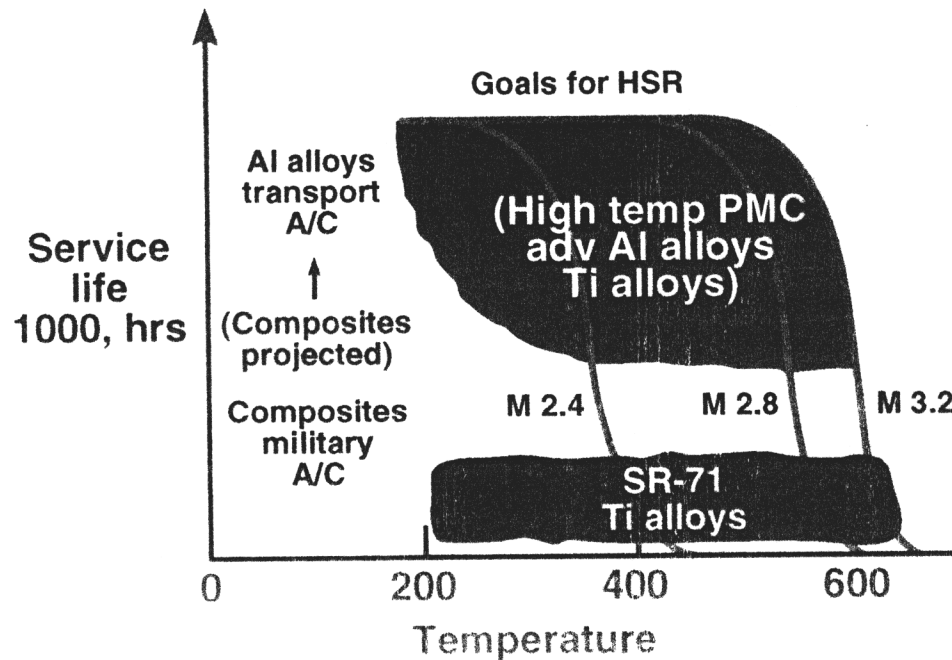

## Key technology needs

- Life prediction methodology
  - Accelerated test procedures
  - Long-term flight simulation durability
- Demonstrated 300°- 500°F polymer matrices, adhesives and sealants for  $\geq 60,000$ -hr lifetimes
- Demonstrated 300°- 600°F lightweight metals and metal matrix composites for  $\geq 60,000$ -hr lifetimes

# Light-Weight Wing Structures With Variable Stiffness Distribution

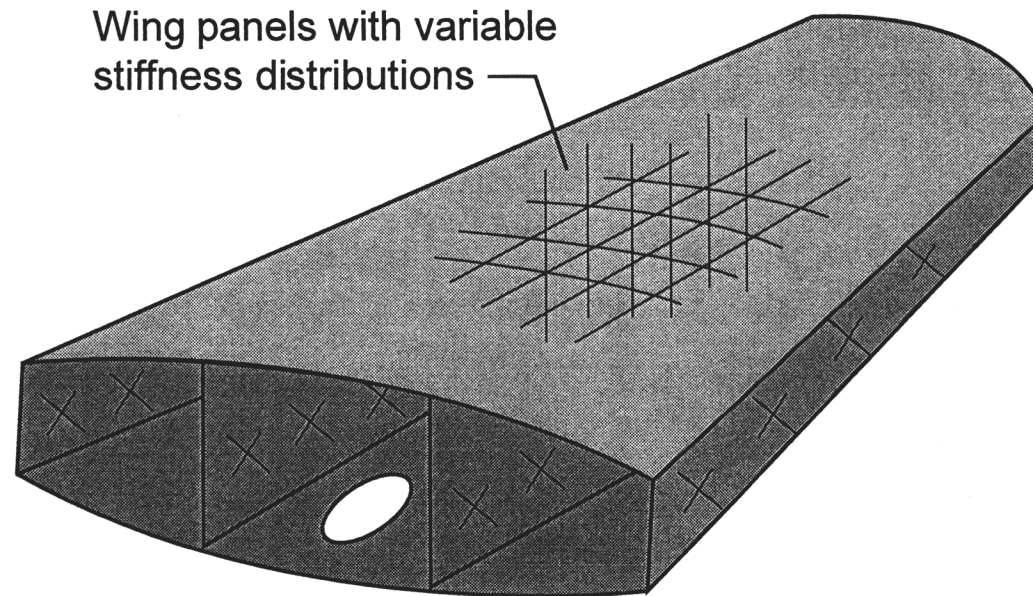

- Potential of significant weight reduction
- Stiffness tailoring to suppress flutter response with no weight increase
- Tailored wing can enable advanced aerodynamic performance

## Light-Weight Fuselage Structures with Variable Stiffness Distribution

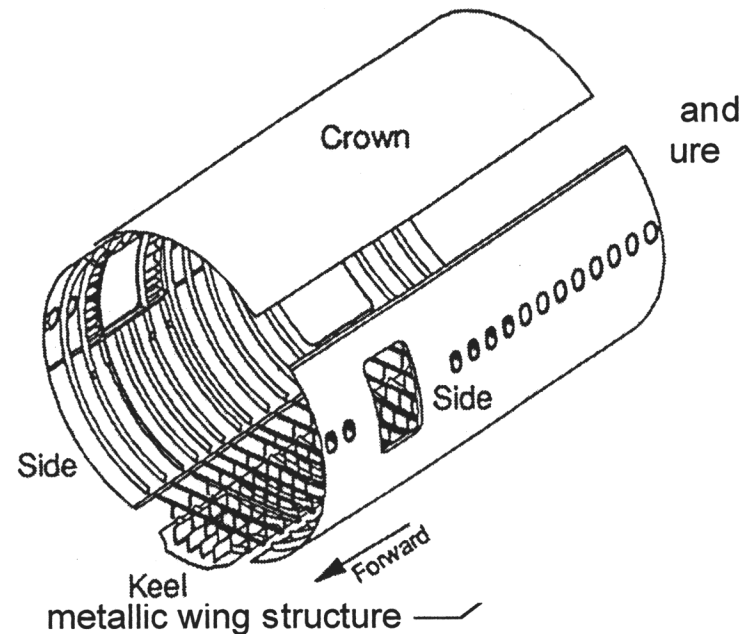

13-118

- Potential of significant weight reduction and assembly cost reduction
- Crown, side, and keel panels with different concepts and stiffness distributions
- Stiffness tailoring to suppress undesirable dynamic responses and to control internal load distribution
- Improved structural integrity for higher-altitude cruise conditions

# Recently Developed Integrated Design Processes Enable Viable Supersonic Configurations

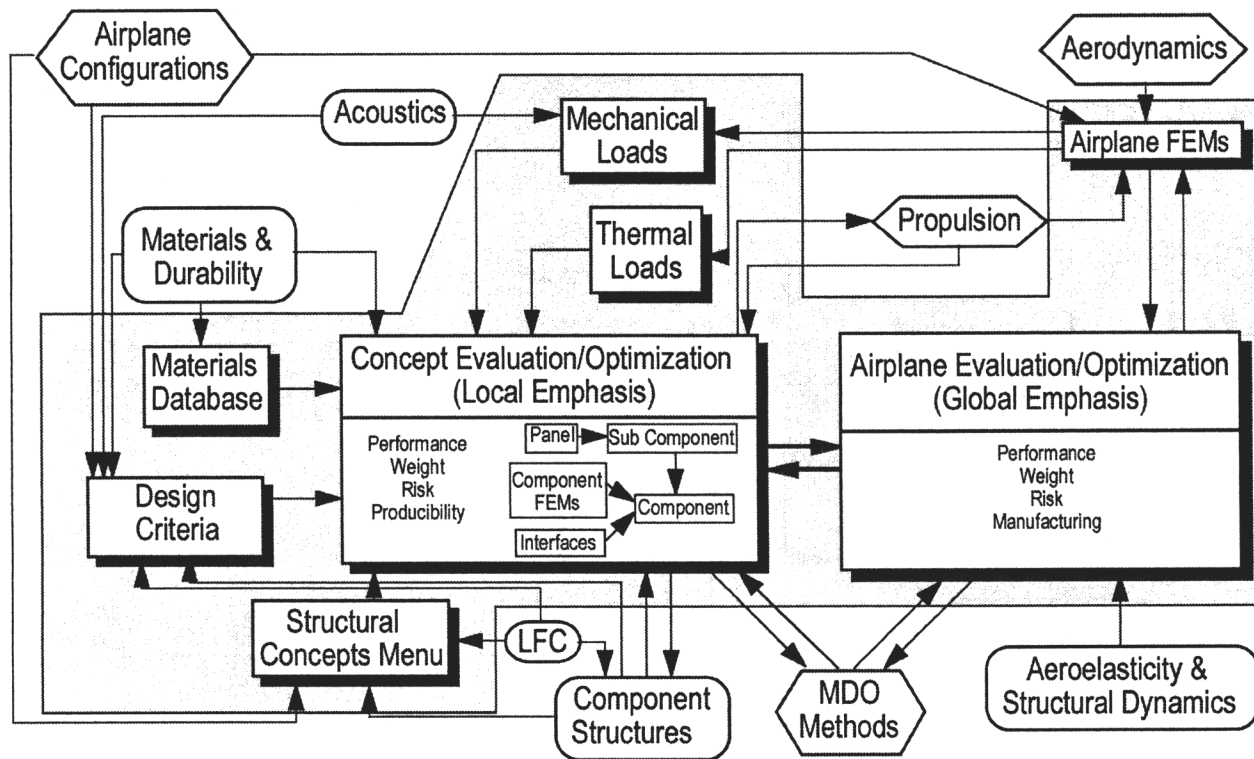

B-119

**SST Designed with Integrated Process Having No Weight Penalty for Preventing Wing Flutter**

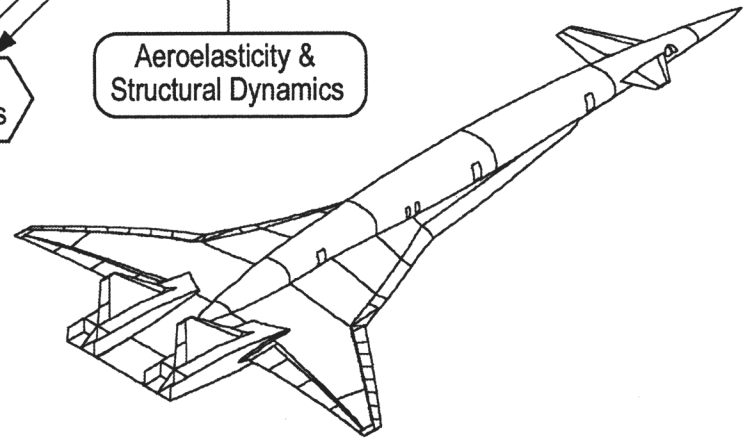

# PETI-5 Composites for HSCT

## Significance

- Resolved enabling HSCT Technology problem on composites
- PETI-5 composites selected for HSCT Durability and Structures Activities
- Provided material to meet other aerospace applications

## Composite Performance

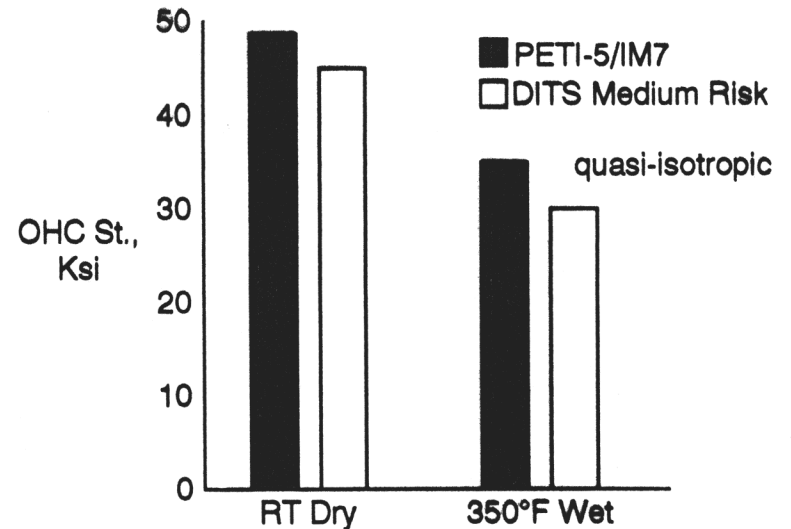

## Cost and Market Projections

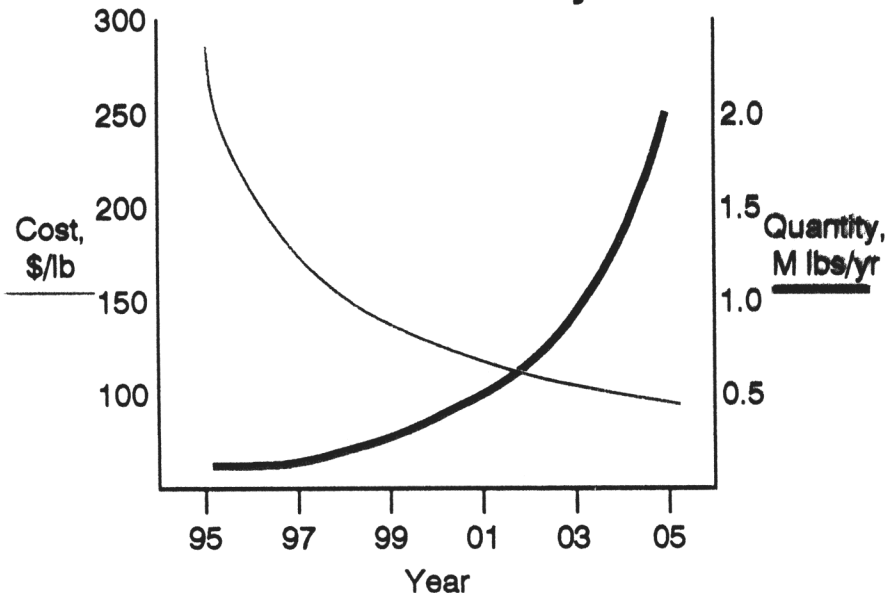

## PETI-5 Composite Status

- Readily processable
- Excellent overall composite properties
- Available in large quantities
- Safe for workers
- Industry acceptance

B-120

# Mechanical Properties



3-121

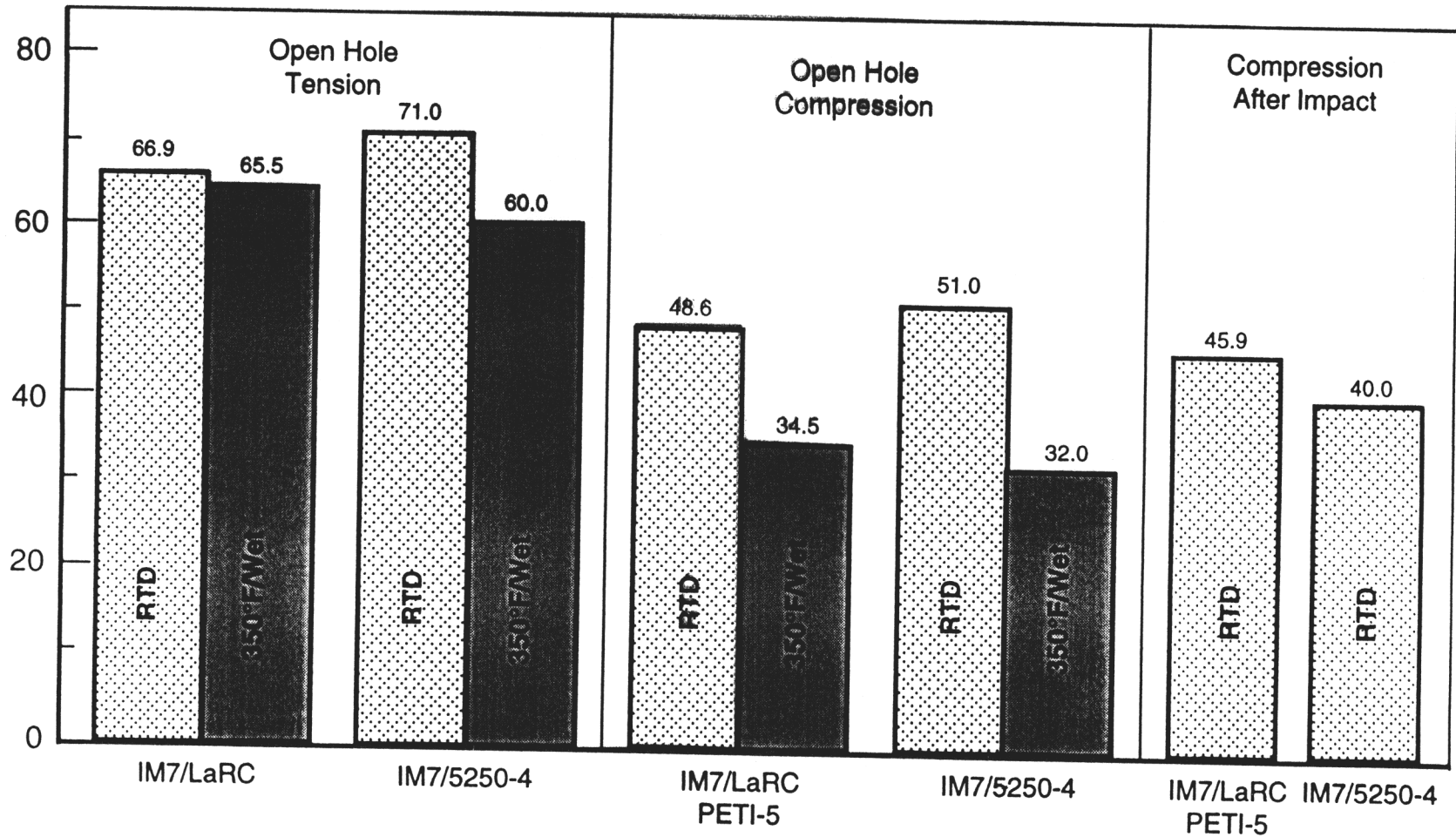

Properties Superior to BMI

**NORTHROP GRUMMAN**

V97-RD/064.ppt



# PETI-5 Wet Sandwich Processing



- 28 ply, 6 ft x 10 ft, IM7/PETI-5 facesheets pre-dried using 232°C (450°F)/4 hours
- 20 piece high and low density titanium core blanket pre-bonded using FMX5-3 (PETI-5)
- Facesheets bonded to core blanket using two layers of FMX5 (PETI-5)

The Boeing Company, Seattle  
HSCT Group

Advanced Materials and Processing Branch

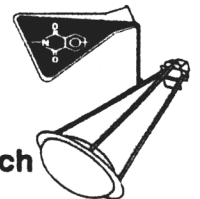

## Advanced Composite Materials and Low-Cost Vacuum Assisted Resin Transfer Molding (VARTM) Process

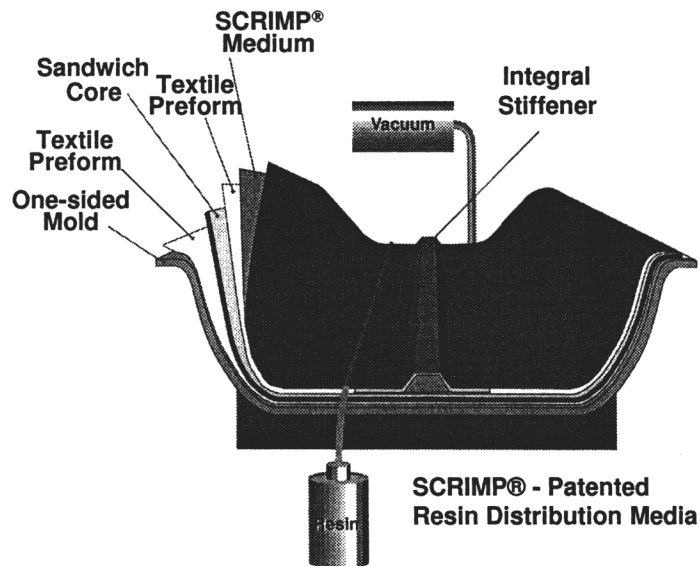

### Advantages of low-cost RTM process:

- Resin and fiber used in lowest cost form
- Prepreg process eliminated
- Freezer storage & shelf life problems eliminated
- Low-cost, one-sided tooling
- Low energy, low pressure out-of-autoclave processing
- Utilizes net-shape, damage tolerant textile preforms
- Large integral structure minimizes secondary bonding and fastening

### Challenges for aircraft applications:

- *Out-of-autoclave cure resins with adequate properties*
- *Dimensional tolerances with low-cost tooling*

# PETI-5/IM7 Skin Stringer Panel (6 ft x 10 ft), Boeing St. Louis

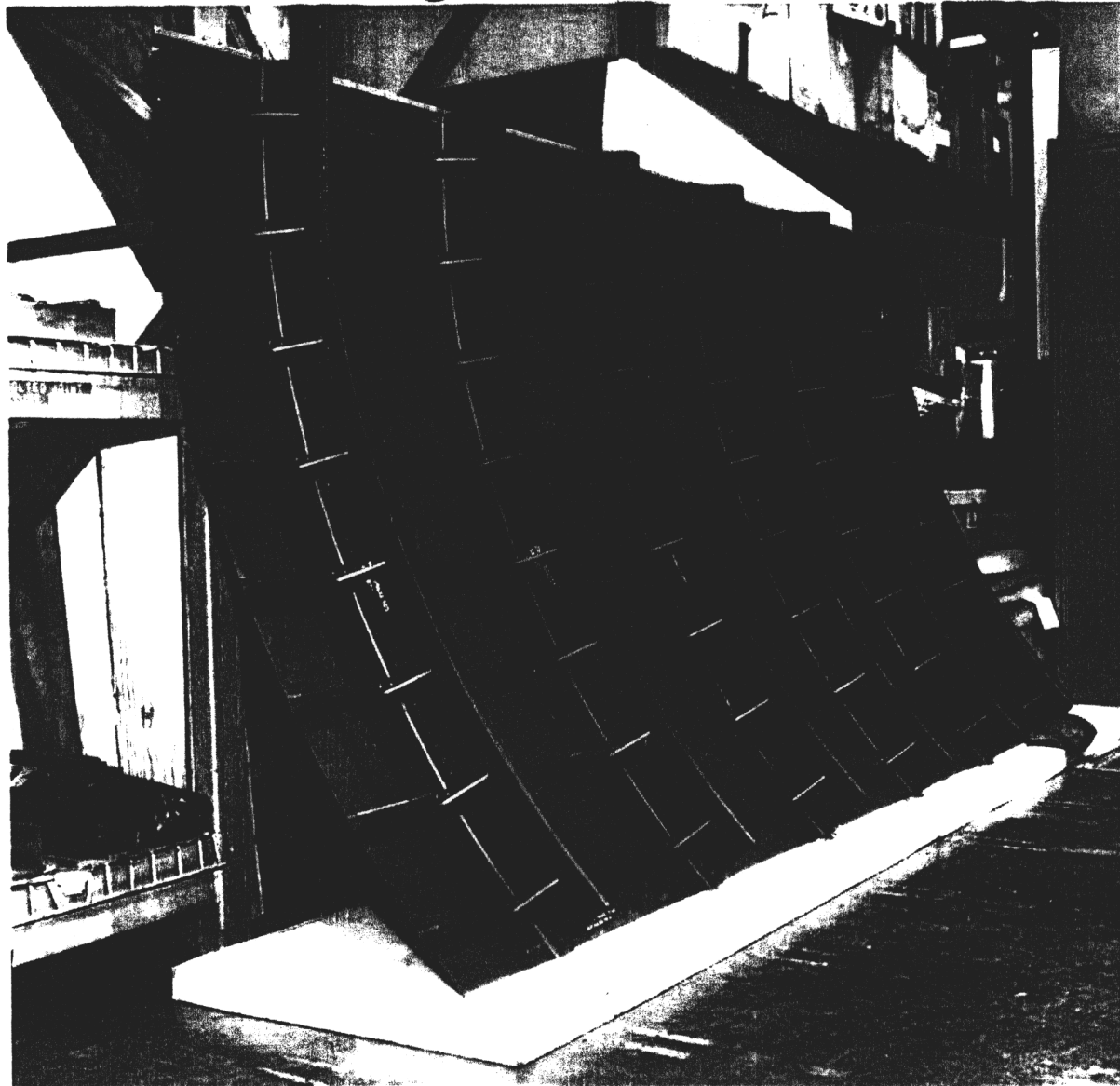

B-124

# Metal/Polymer Matrix Composite Hybrid Materials for Wing and Fuselage Structures

B-125

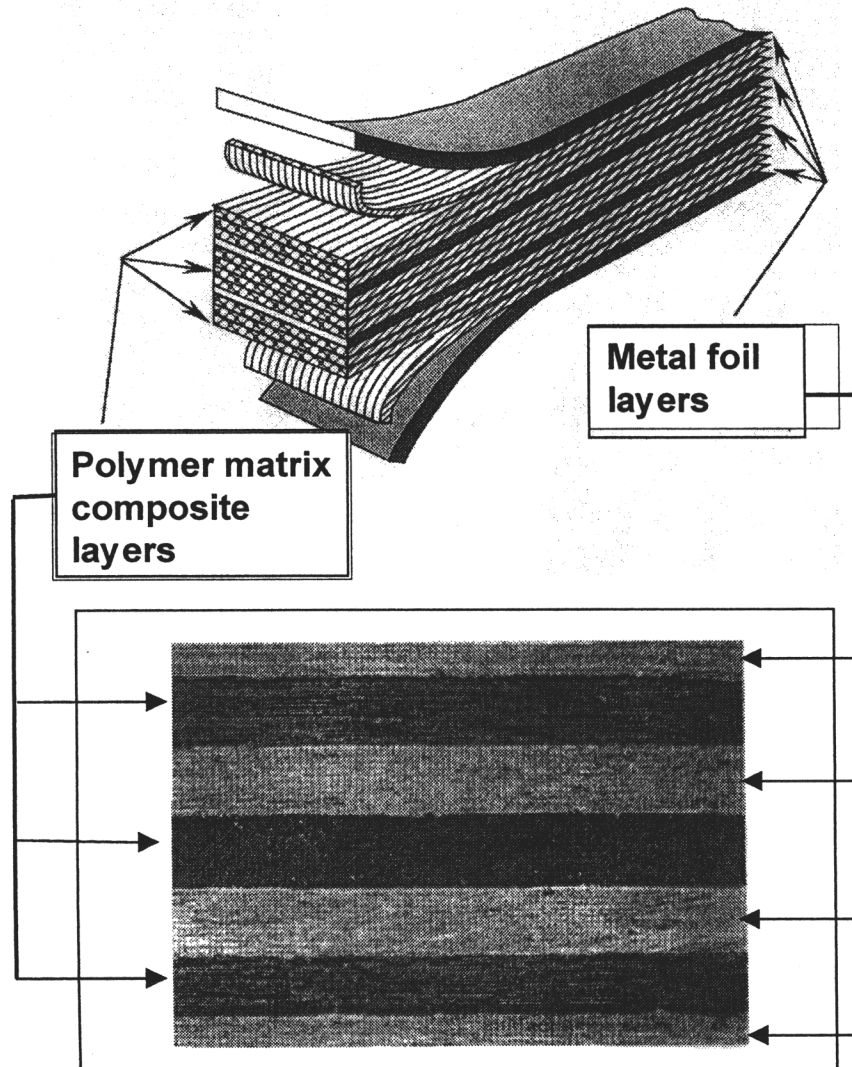

- Improved strength & stiffness to density ratio → Lower weight
- Improved fatigue life & crack growth resistance → Longer life
- Metal-like lightning strike protection → improved safety
- Enhanced damage tolerance → reduced repair
- Metal outer layers → environmental protection, durability
- Unequal modulus → improved in-plane damping

# Elevated Temperature Aluminum Alloys Demonstrate Property Improvements over Existing SST Alloys

Strength-Toughness Combination of Advanced Aluminum Alloys

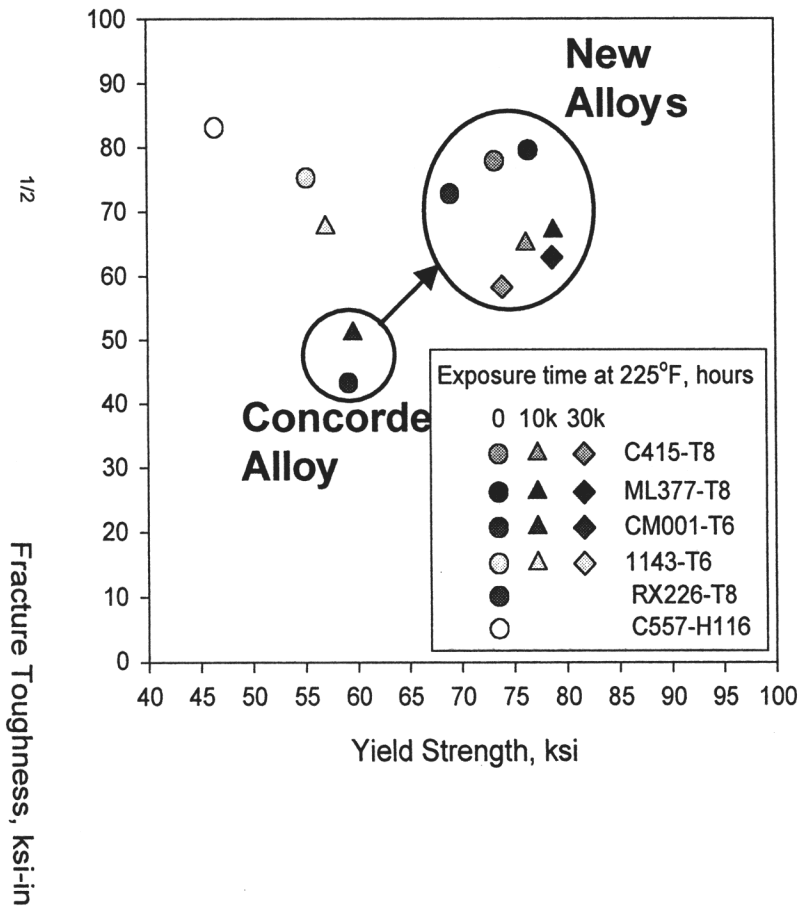

- Significant Strength-Toughness improvements over Concorde alloy
- Properties retained after 30,000 hours exposure at 225°F (Mach 2 conditions)
- Superior creep resistance compared with Concorde alloy
- Newer developmental alloys show promise for improved properties
  - higher strength and toughness with improved thermal stability
  - superior corrosion resistance
- Newer ultra-low-density alloys offer significant weight reduction with improved properties

# Elevated Temperature Yield Strength of New HSR Aluminum Alloys

B-127

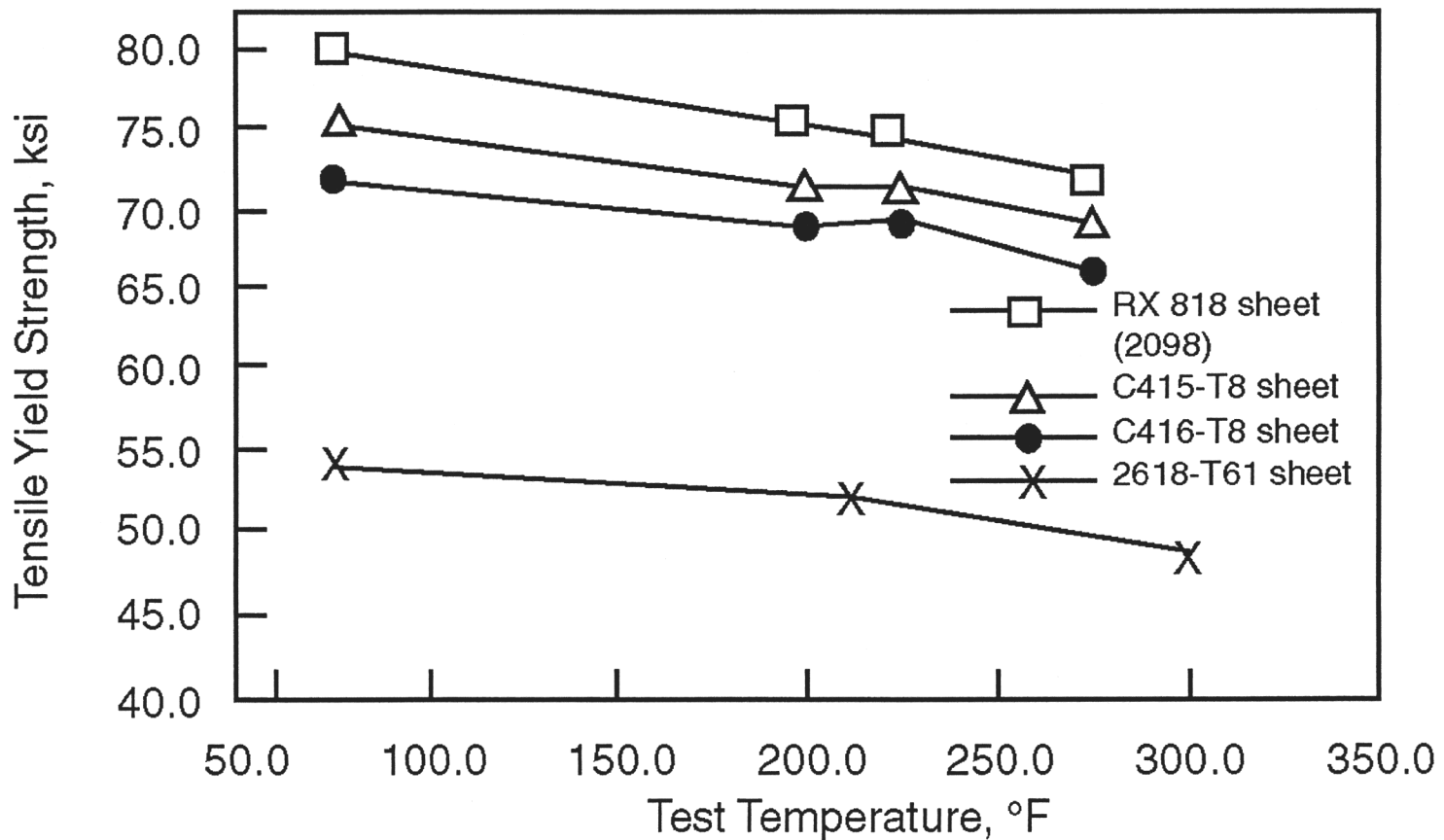

# Strength-Toughness Performance of Al-Mg-Sc Compared with Airframe Skin Alloys



B-128

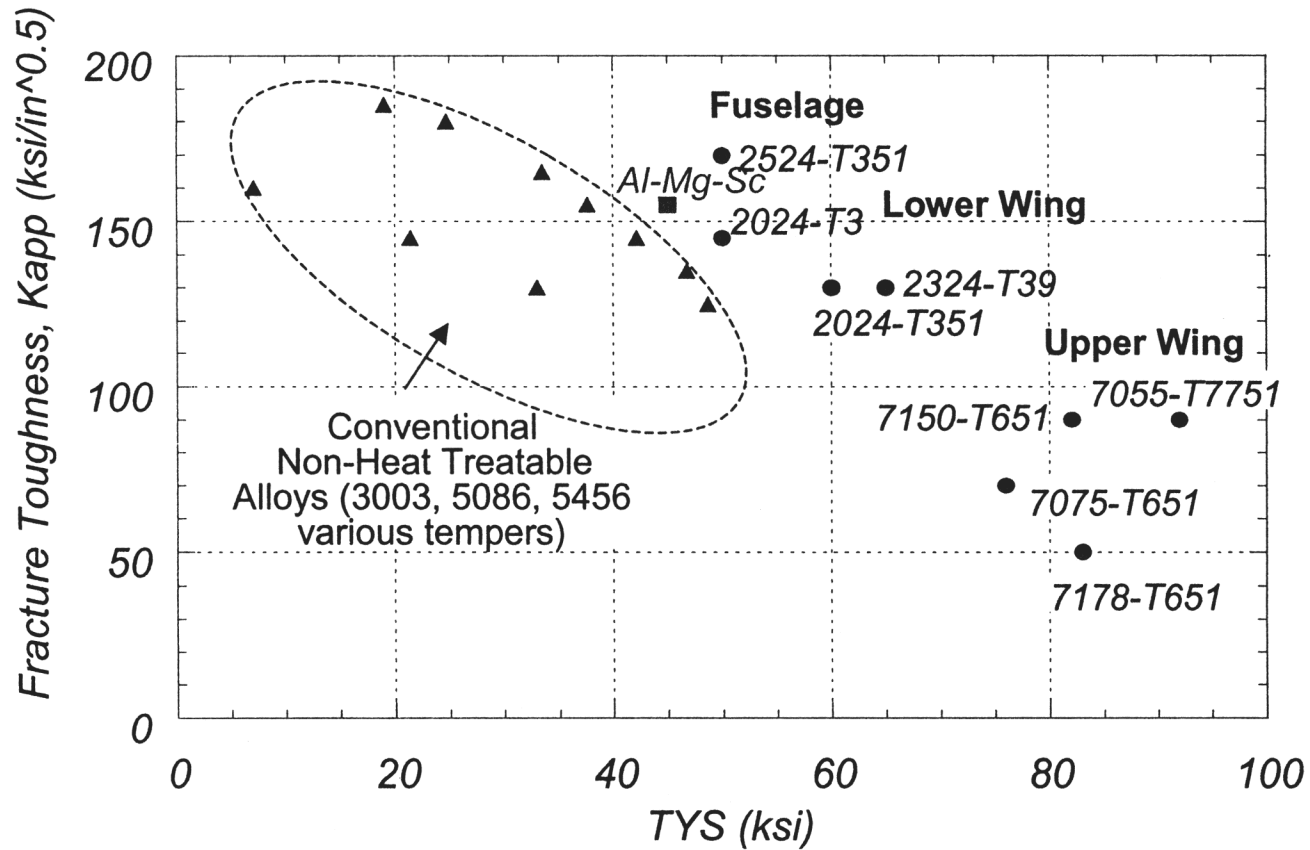

## Benefits of Al-Mg-Sc:

High strength-toughness combination  
Good corrosion resistance

Non-heat treatable alloy  
Density = 0.096 lb/in<sup>3</sup>

# Benefits of **Friction Stir Welded Joints** vs Riveted Joints

---

## **Generates Weight Savings**

- contributes to sonic boom, fuel-use and emission reductions
- eliminates fastener and butt strap weight
- eliminates fuel sealants

## **Generates Cost Savings:**

- reduces part count
- reduces assembly costs
- reduces design costs
- reduces maintenance costs

## **Improves Joint Quality and Reliability**

- eliminates of stress concentration at fastener holes
- improves fatigue performance though elimination of stress concentration
- eliminates interfaces, moisture ingress, fretting

## **Improves In-Service Performance**

- improves fatigue performance to give increased inspection threshold intervals

## **Enables Innovative Designs**

- process enables a fresh, “out-of-the-box” approach to structural concept design
- enables decoupling of geometry changes from load transfer/joining function

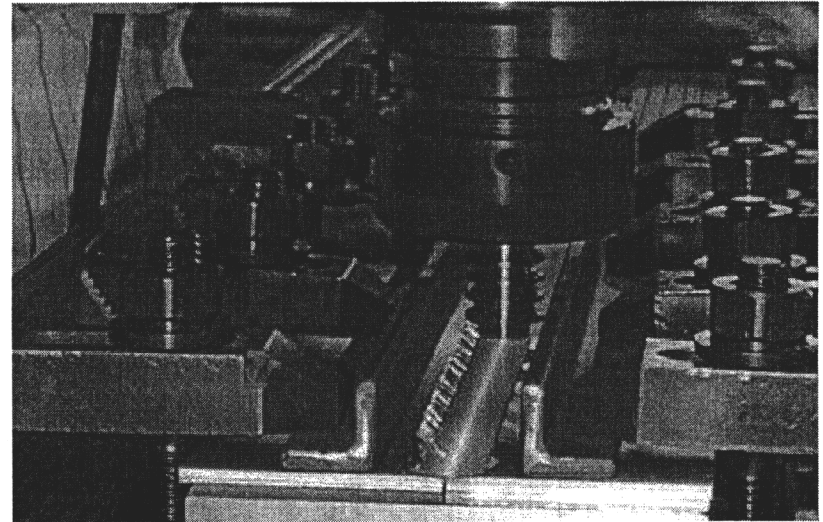

# Heat Treat Selection for Primary Titanium Sheet Down-Select Alloys

B-130

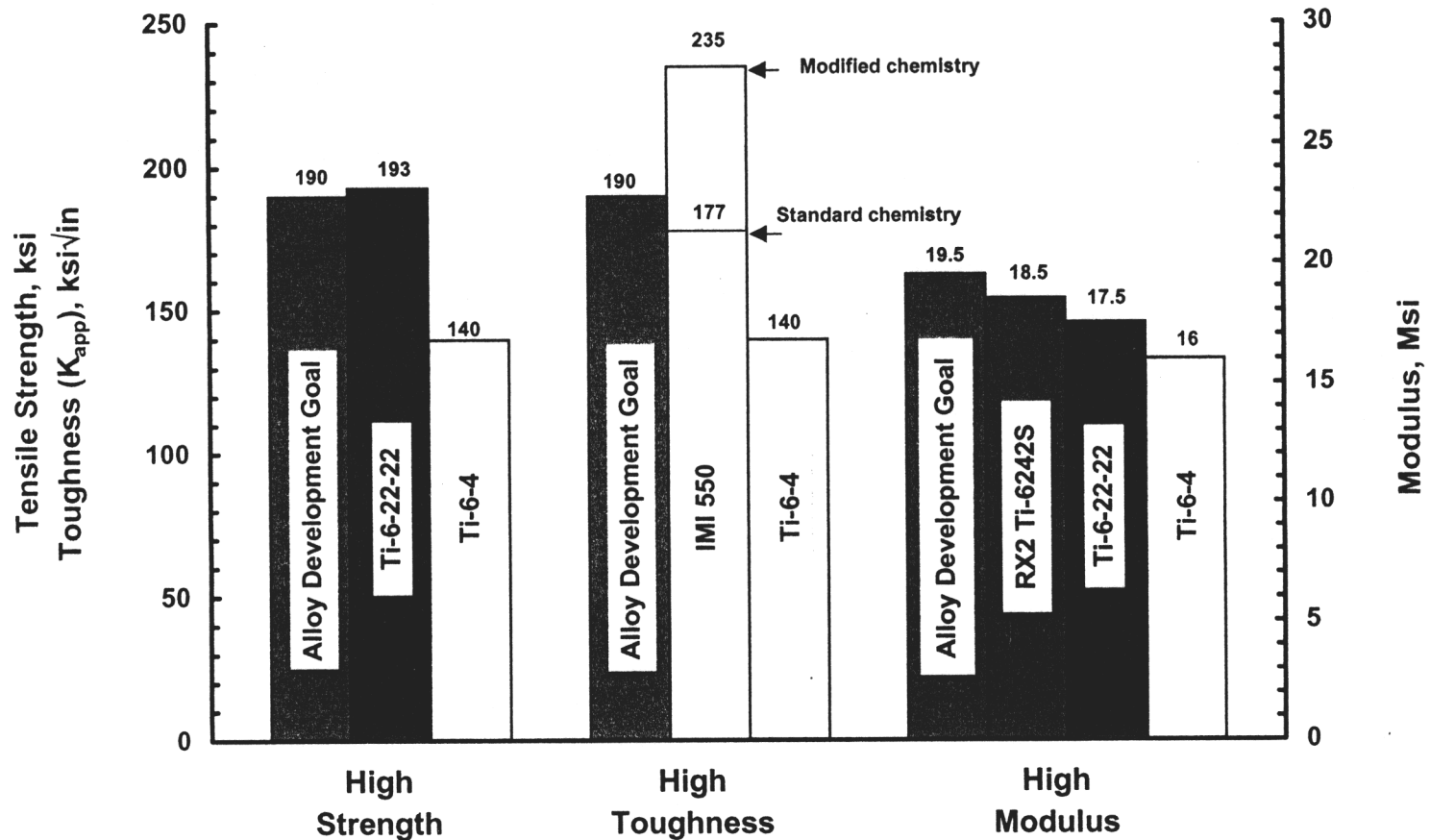

<u>High Strength Variant</u>	<u>High Toughness Variant</u>	<u>High Modulus Variant</u>
ST: 1650°F ± 25°F / 30 min	ST: β <sub>T</sub> - 50°F ± 15°F / 30 min	ST: β <sub>T</sub> - 10°F to β <sub>T</sub> - 40° / 2 hrs
Cool: 100° to 400°F/min (Between ST & ST-180°F)	Cool: Furnace cool @ ~ 5° to 50°F/min	Cool: Controlled cooling (60°F/min ± 30°F / min)
Age: 930°F ± 25°F / 8 hrs	Age: 930°F ± 25°F / 8 hrs minimum	Age: 1100°F / 8 hrs

# Assembly of Titanium Honeycomb Sandwich Panel and Core Configuration

High Speed Civil Transport

B-131

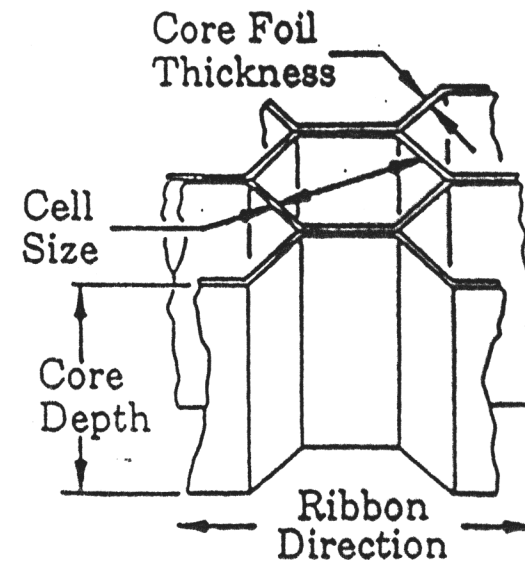
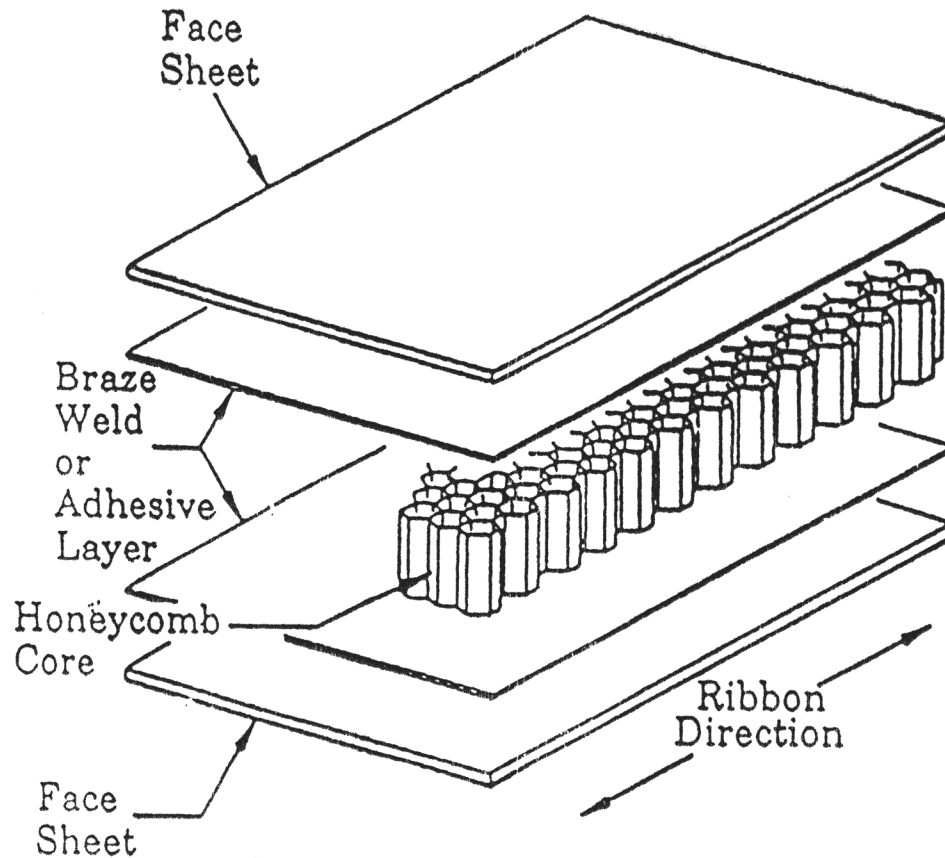

# SPF/DB Titanium 4 Sheet Sandwich Fab

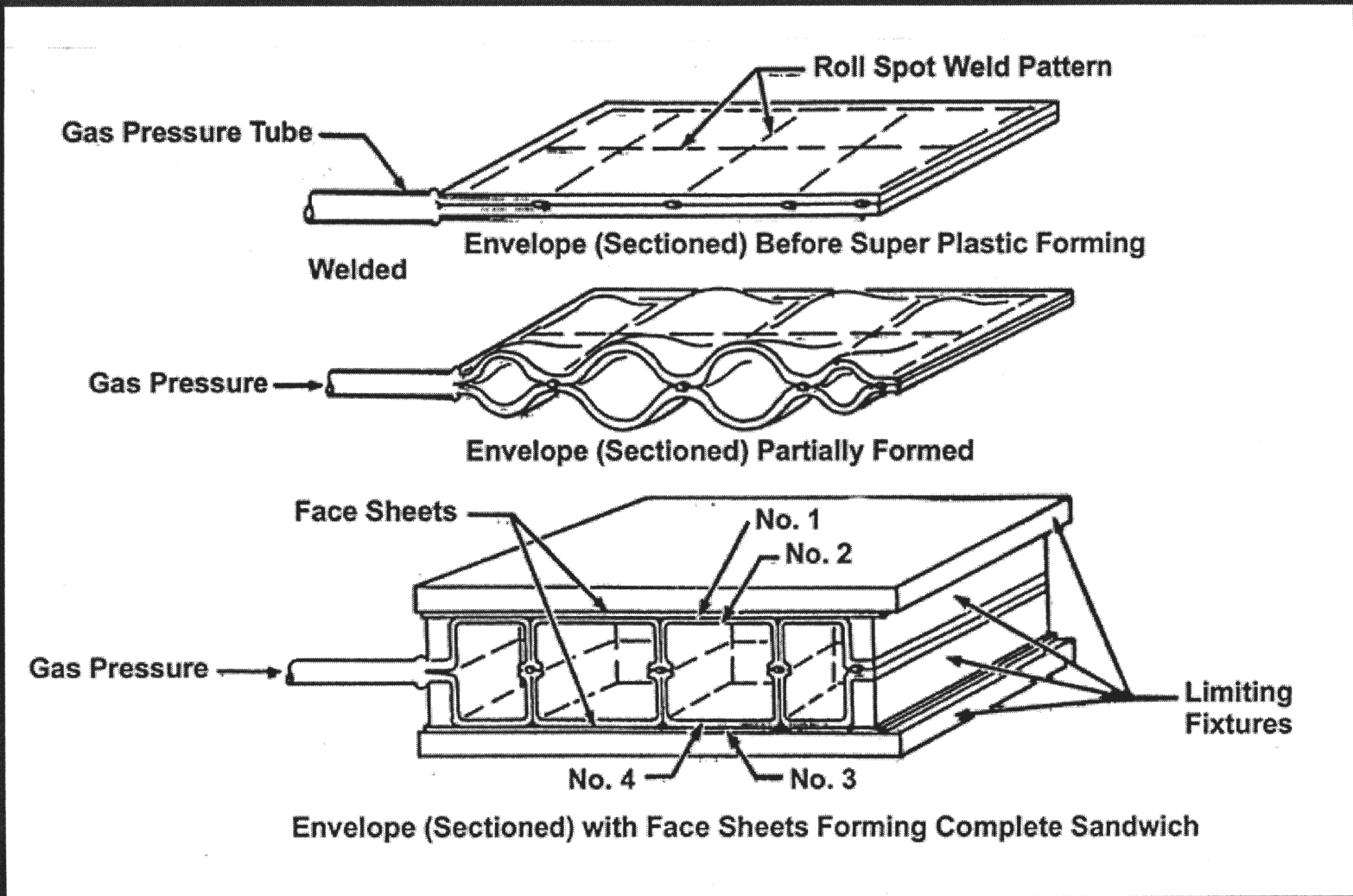

B-132

# Weld-Bonded SPF Beaded Web Truss Core Sandwich

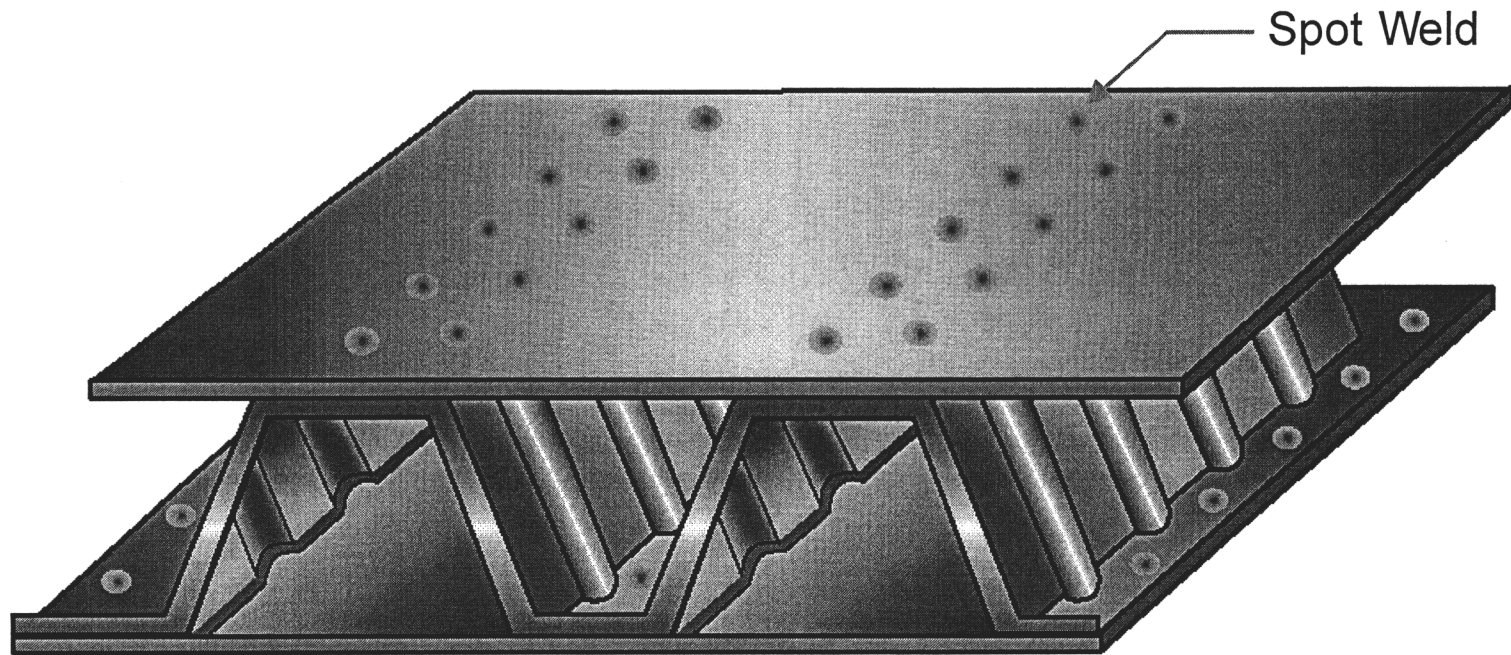

B-133

**DARPA QSP FOCUS GROUP MEETING**  
**ON**  
**MATERIALS AND STRUCTURES**

**Haydn N.G. Wadley**

University of Virginia, Charlottesville, VA 22904

( 434 924-0816/ haydn@virginia.edu)

Tuesday, June 26, 2001

Work supported by DARPA (Leo Christodoulou) and ONR (Steve Fishman)

# Classes of 3-D Cellular Metals

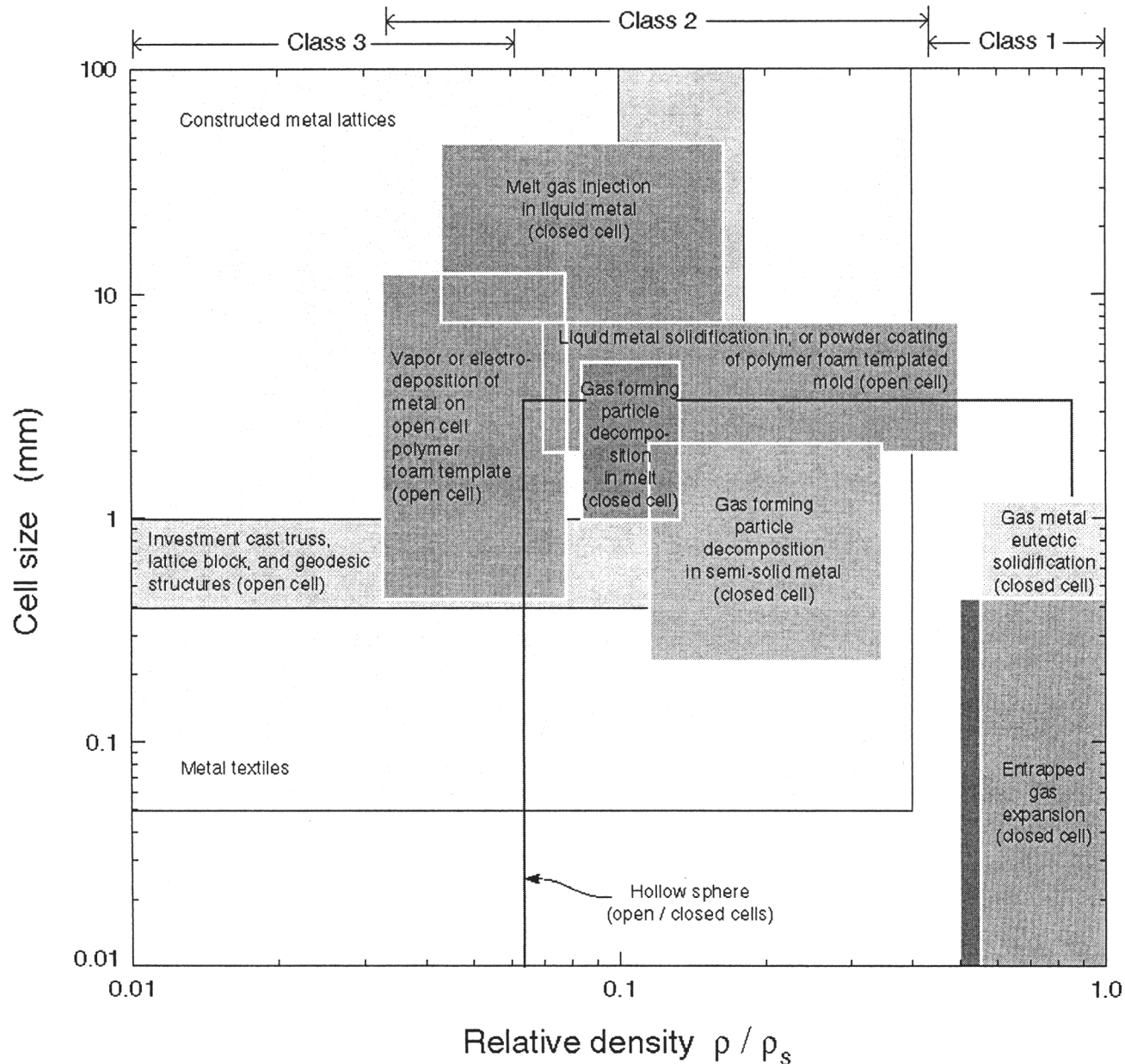

## Class 1

Porous metals:  
closed cell

$$0.5 < \rho / \rho_s < 1.0$$

## Class 2

Stochastic metal foams:  
open / closed cell

$$0.03 < \rho / \rho_s < 0.5$$

## Class 3

Periodic metal trusses:  
open cell

$$0.01 < \rho / \rho_s < 0.02$$

B-135

# Cellular Metals

## Cellular Metals

Stochastic

Duocell  
ALPORUS (FORMGRIP)  
Cymat  
Alulight  
Porvair  
Incofoam  
DVD foam  
Syntactic foam  
Hollow sphere, etc.

Periodic

Prismatic

Rapid prototyped  
Georgia Tech oxide precursor  
extrusion  
Metal Extrusion  
SPF/DB Honeycomb

Lattice / truss

Lattice block material (LBM)  
Tetragonal truss  
Woven microtruss  
Constructed cellular solid  
Geodesic structures  
Electrodeposited microtruss

B-136

# Topologies of Periodic Cellular Metals

Lattice Block Material (Jam Corp)

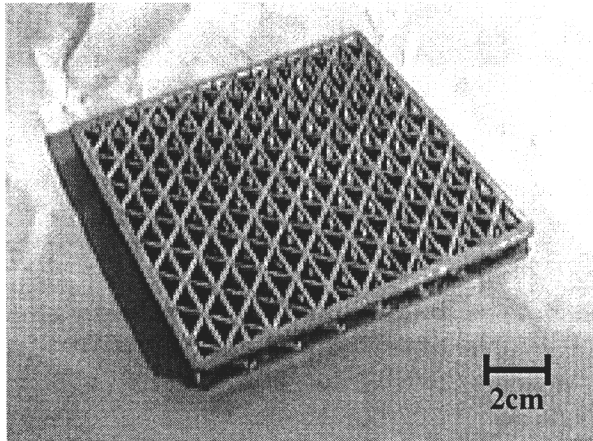

Tetragonal Truss Core Panels (MURI)

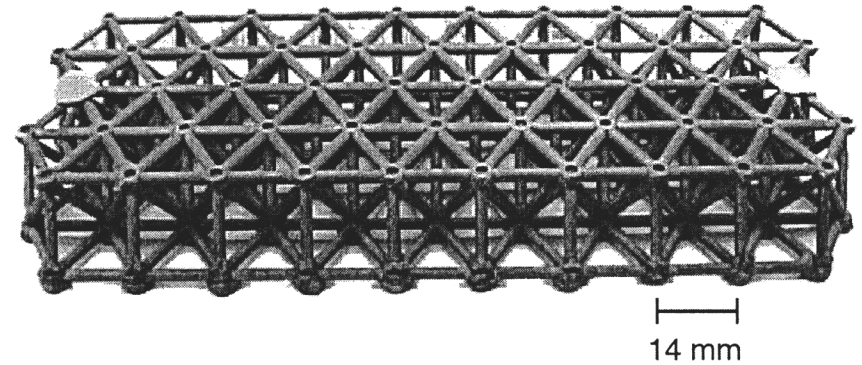

Woven Micro Truss (MURI)

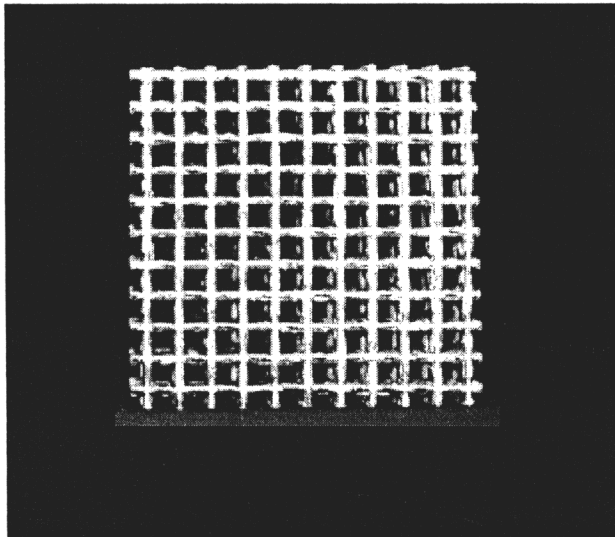

Constructed Cellular Solid (MURI)

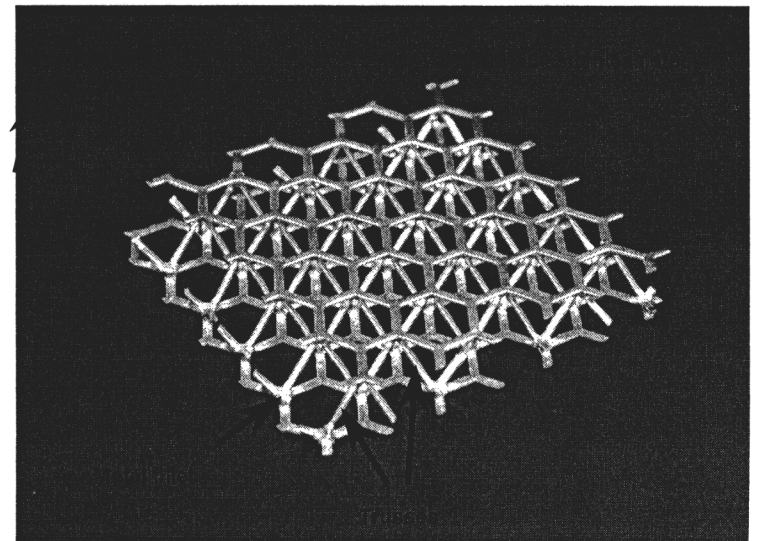

# Cellular Metal Manufacturing

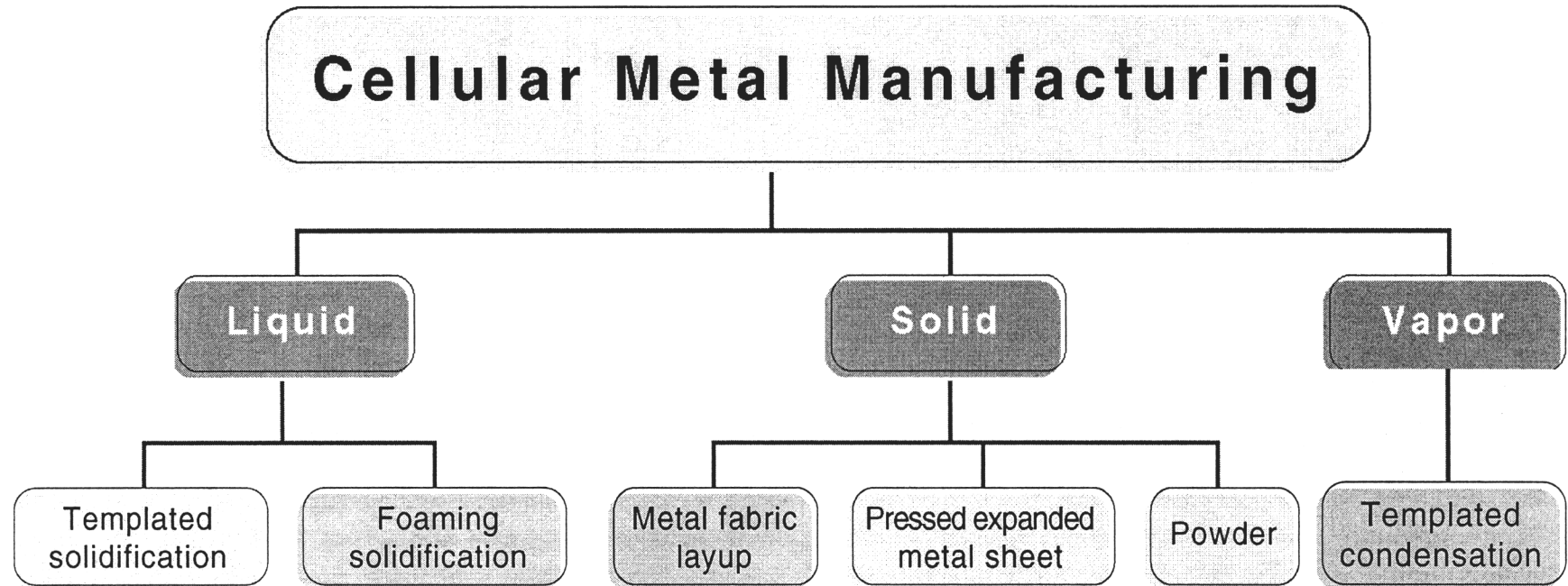

3-138

# Periodic Cellular Metals

B-139

# Tetragonal Lattice Structure

**Harvard MURI:** (Harvard/Princeton/Cambridge/MIT/UVA).

**Process:** polymer template/investment casting. Infiltrate with ceramic slurry, burnout polymer, fill with liquid metal, solidify.

**Materials:** Cu-2% Be, Bronze, Al, Ni, Fe casting alloys.

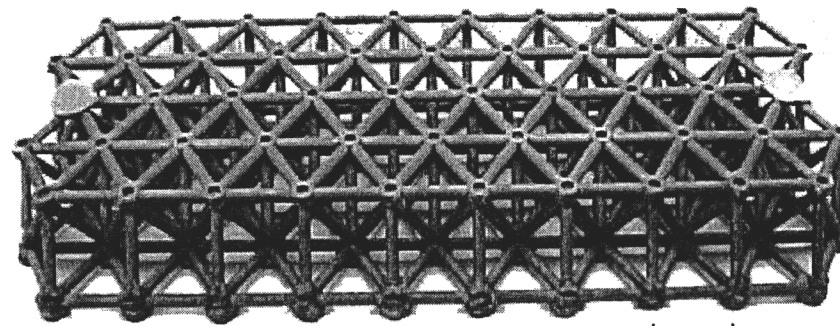

Injection Molded +  
Investment Casting  
Route

Rapid Prototyping + Investment Casting

14 mm

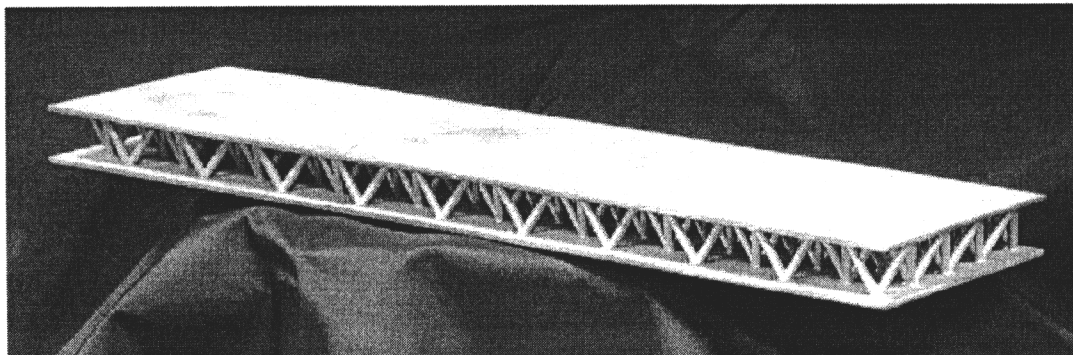

**Cell Size: 2-20mm**

**$\rho/\rho_s$ : 1-10%**

Reference:

S. Chiras, D.R. Mumm, A.G. Evans, N. Wicks, J.W. Hutchinson, S. Fichter, K. Dharmasena, and H.N.G. Wadley, International Journal of Solids and Structures, submitted (2001).

B-140

# Fused Deposition Modeling Process

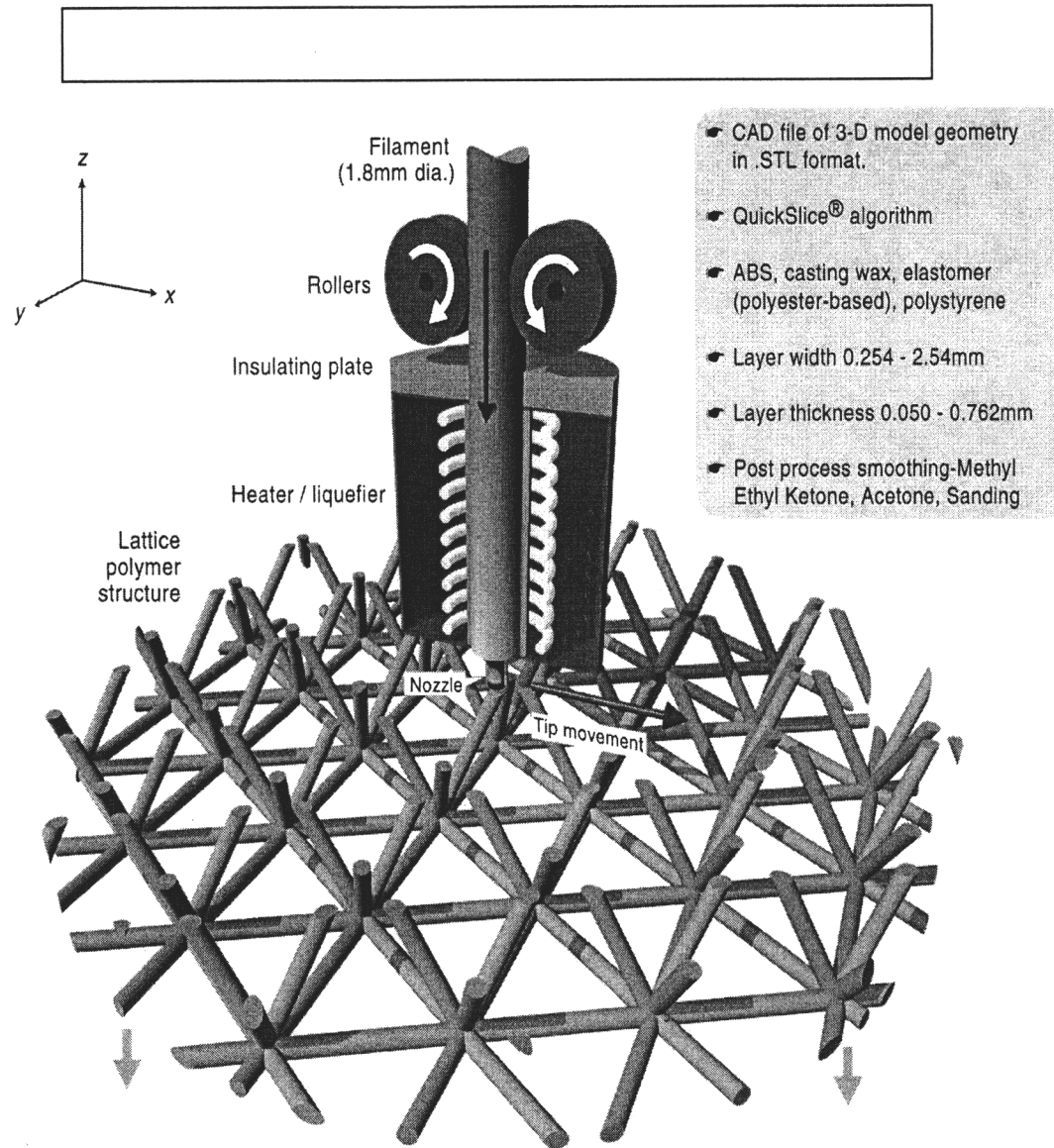

B-141

# ABS (octet truss core) Patterns

Truss Facesheets

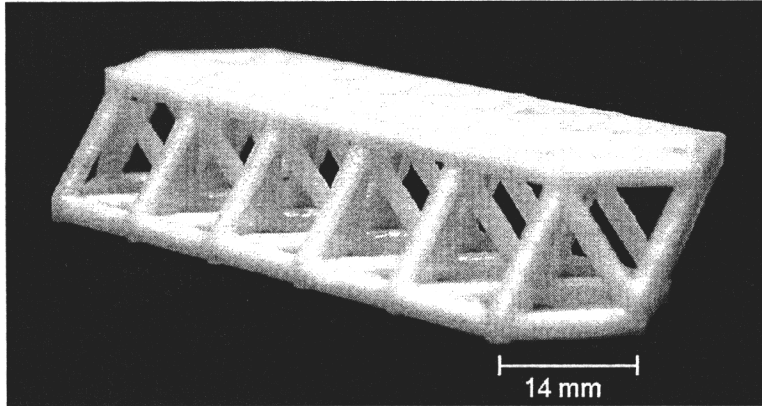

Solid Facesheets

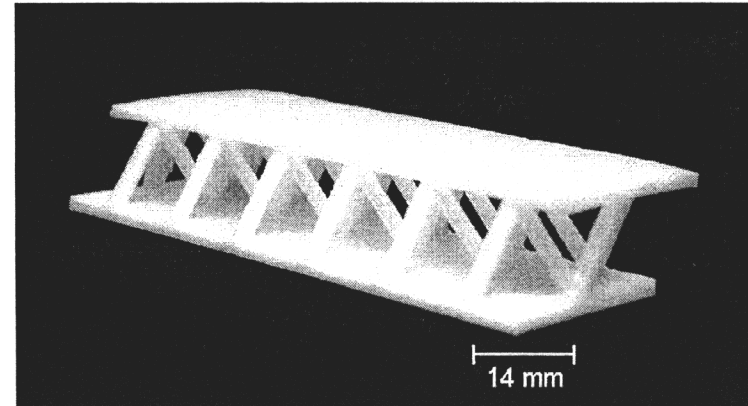

Wicks – Hutchinson Structure

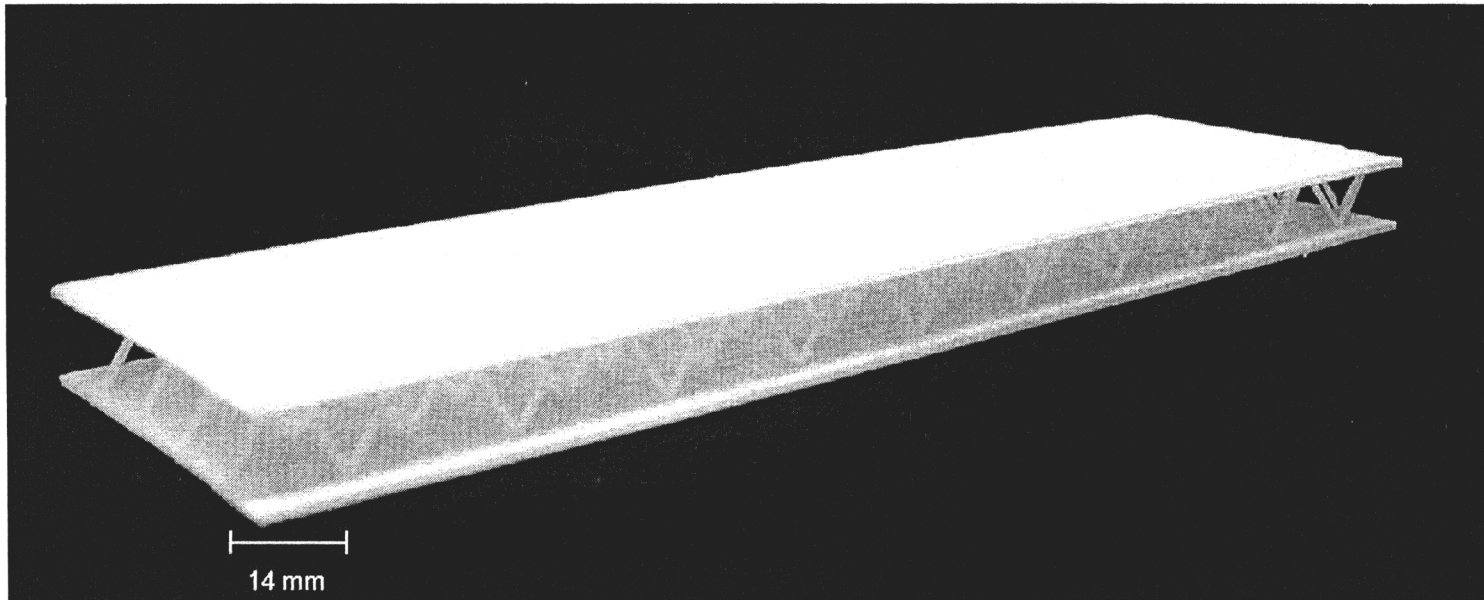

B-142

# Rapid Prototyping

Fused Deposition Modeling (FDM 3000)

Pillar  
Array

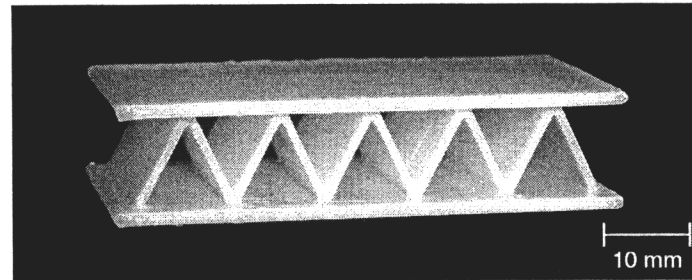

Cross Pillar  
Array

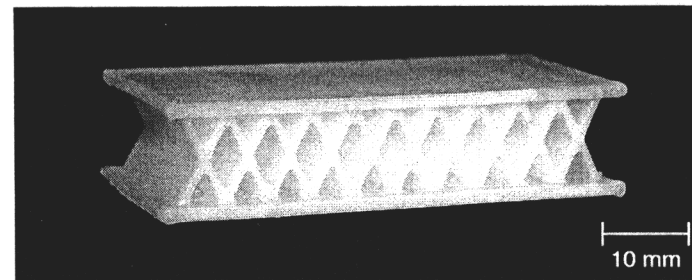

Channel  
Array

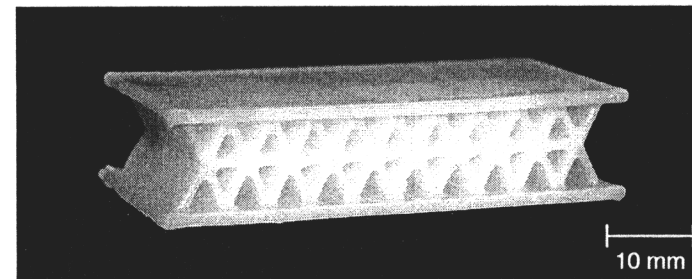

B-143

# Kagome Core Sandwich Panels

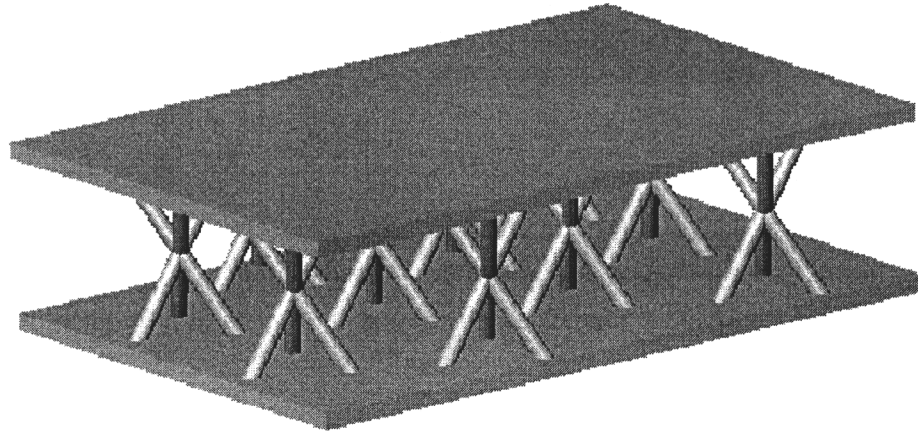

B-144

# LBM – Lattice Block Materials

JAMCORP

**Processing:** Investment casting using injection molded templates.

**Applications:** Automobile, naval, and aerospace components, building structures, furniture and sporting goods.

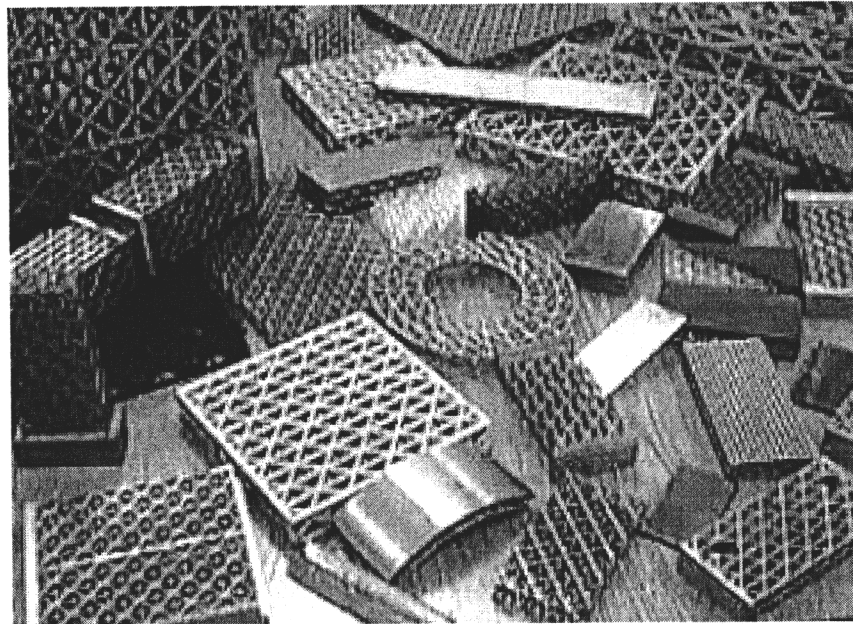

Cell Size: 5-50mm

$\rho/\rho_s$ : 5-15%

**Issues:** Cast ability of large panels, casting factor knock-down, limited set of alloys, cost.

# Woven Micro Truss

University of Virginia (Sypeck/Wadley)

Process: plain metal weave lay up/transient liquid phase bonding

Materials: aluminum 6061, copper alloys, Inconel, Ni-base superalloys, Ti-6Al, austenitic stainless steels,.....

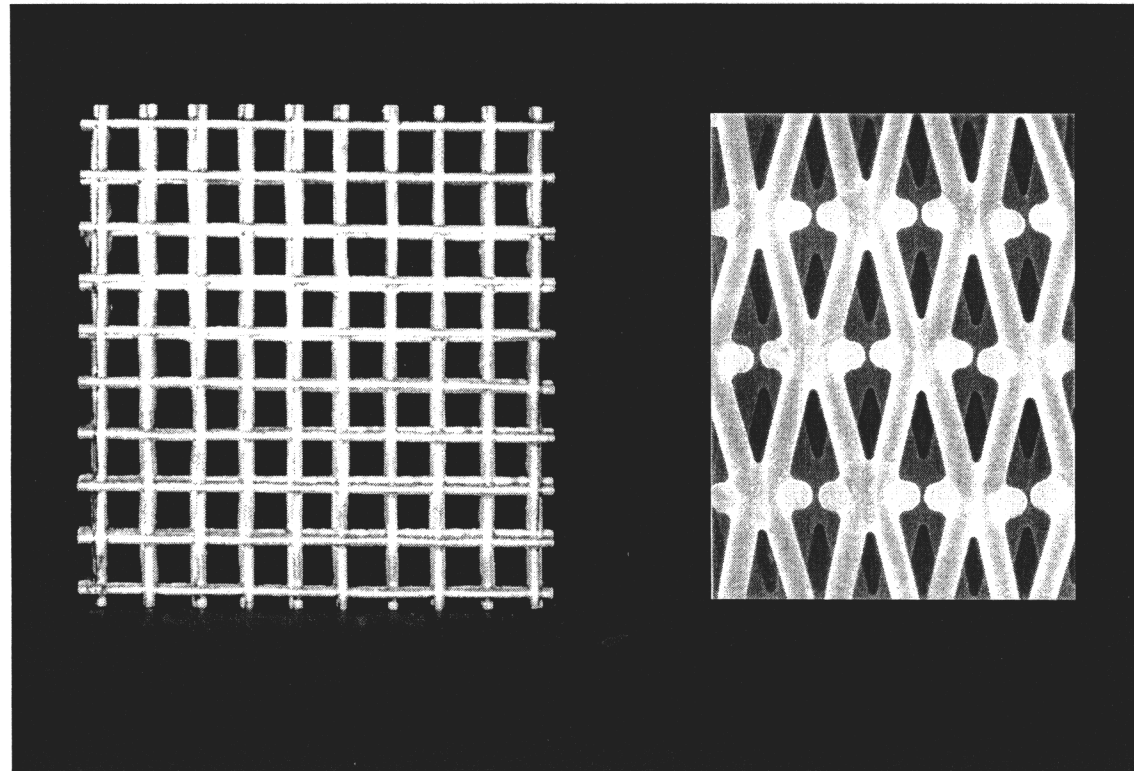

Availability: 1-50 pores per inch

$\rho/\rho_s: <0.2$

B-146

# Lamination Construction

a) 2D woven metal structure

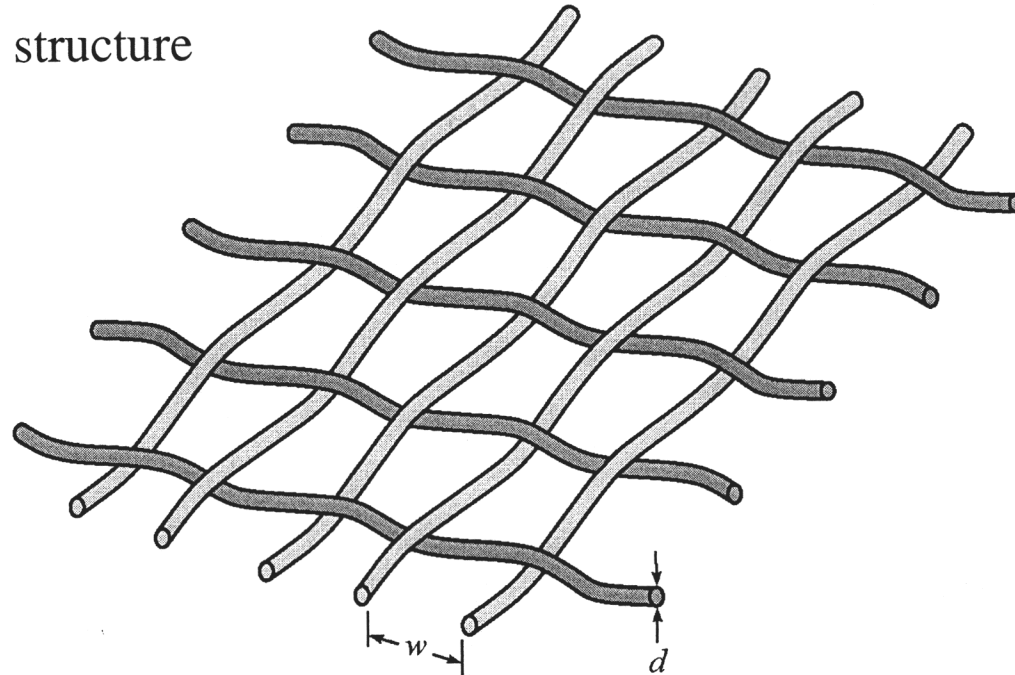

b) Woven metal micro-truss laminate

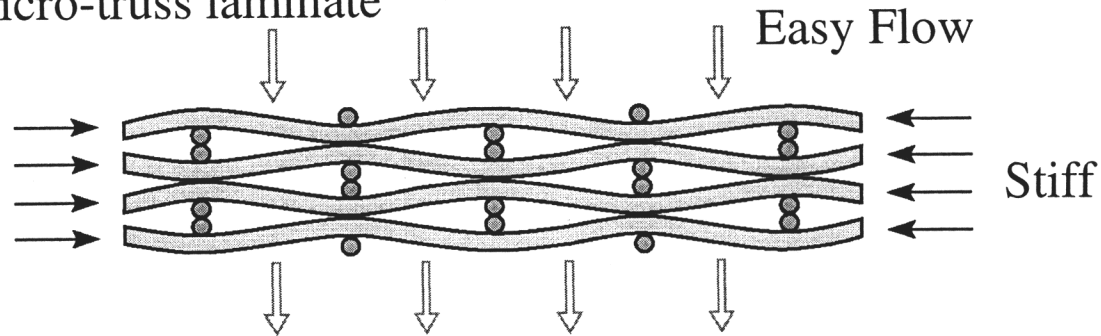

$$\rho/\rho_s \approx \pi d/4(w+d)$$

$$E/E_s \approx 0.5\rho/\rho_s$$

$$\sigma_c/\sigma_{ys} \approx 0.5\rho/\rho_s$$

B-147

# Bonding Method

a) Micro-truss laminate core construction

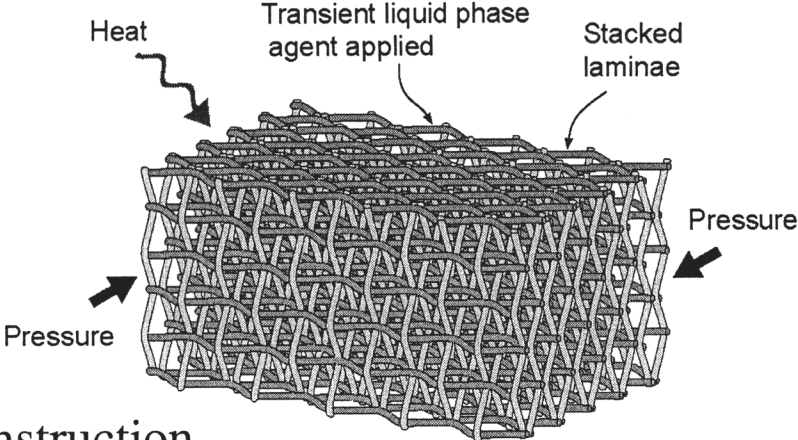

8-148

a) Sandwich panel construction

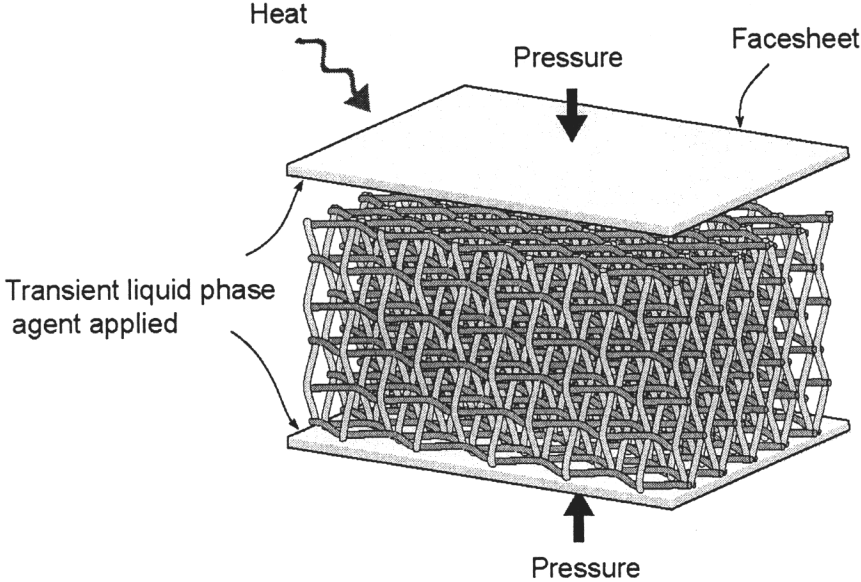

# Liquid Phase Sintering

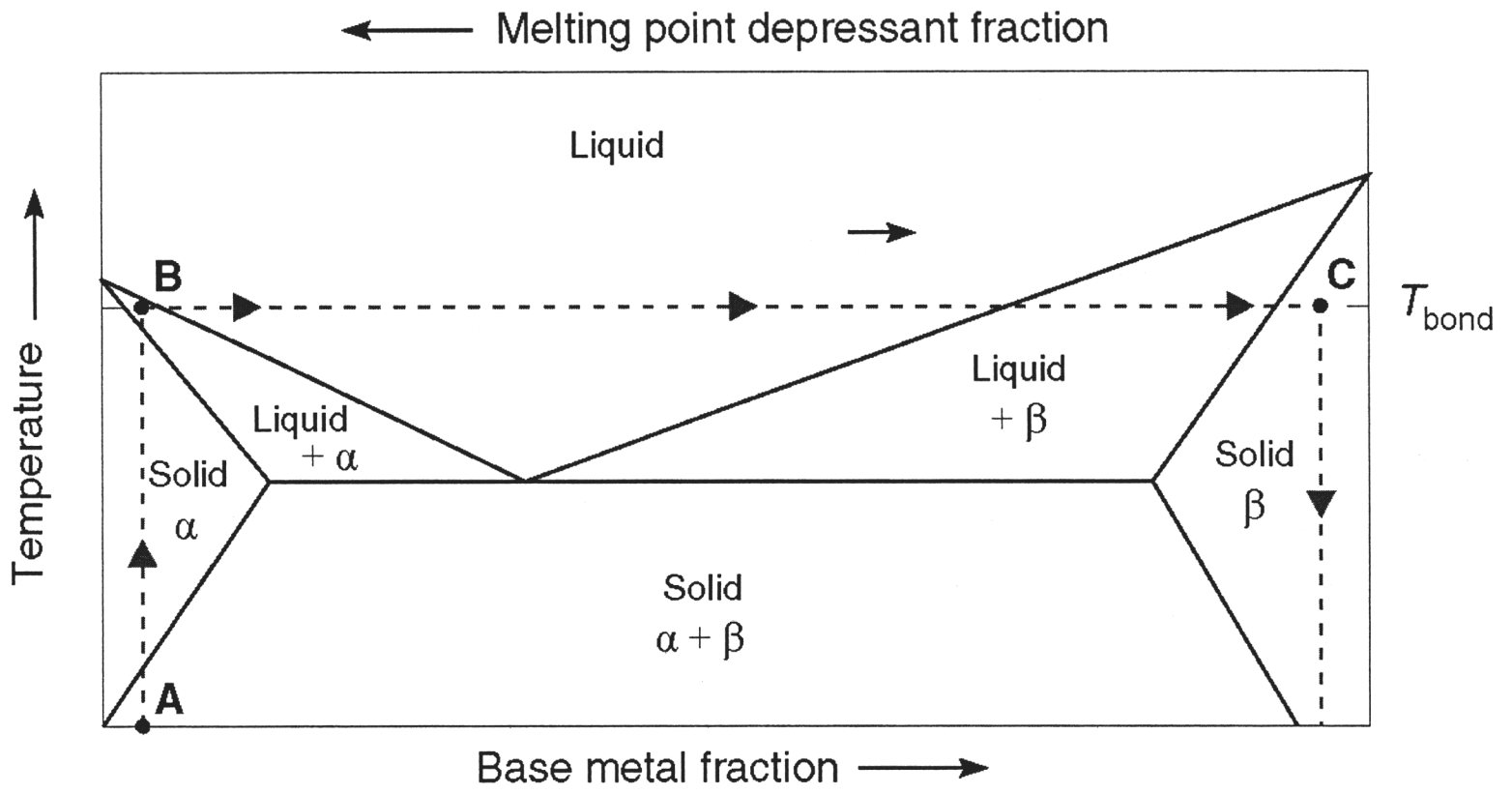

B-149

# Multifunctional Micro-Truss Laminate (nichrome)

Easy Fluid Flow

Excellent Load Support

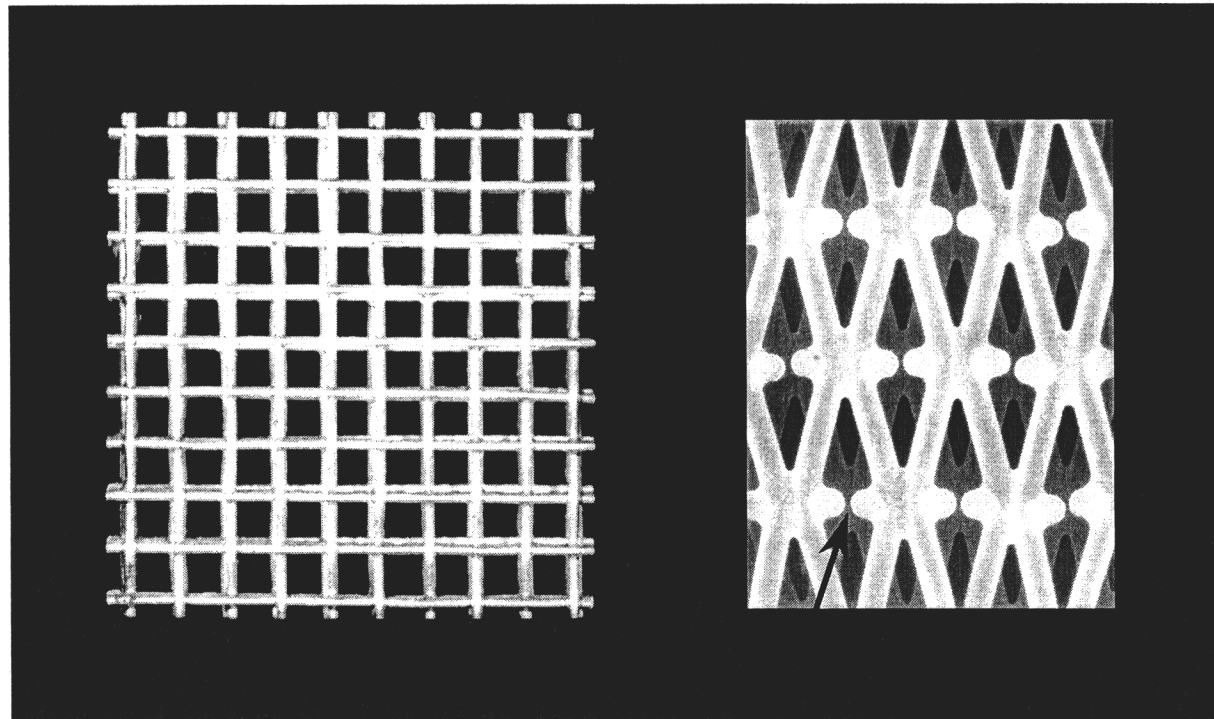

B-150

# Compressive Mechanical Properties

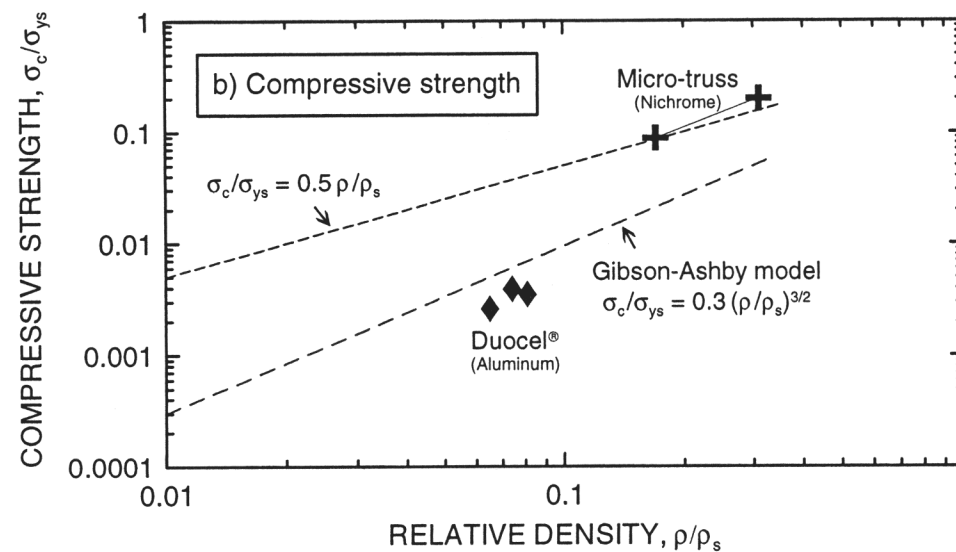
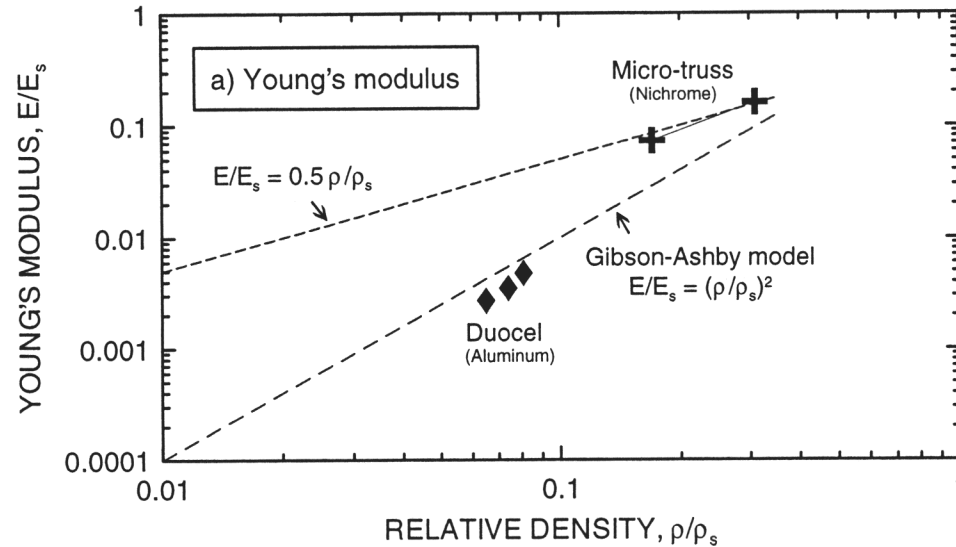

Reference: "Multifunctional Micro-Truss Laminates: Textiles Synthesis and Properties", D. Sypeck and H.N.G. Wadley, Journal of Materials Research, Vol. 16, No. 3 (2001).

# Materials Diversification

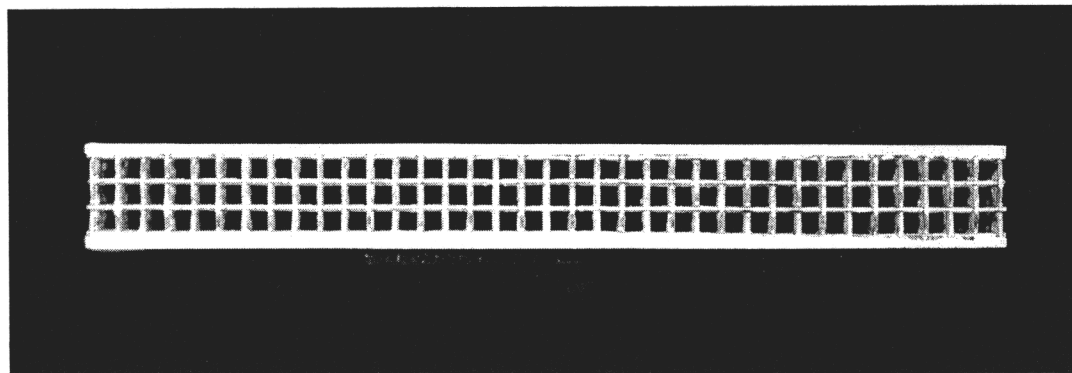
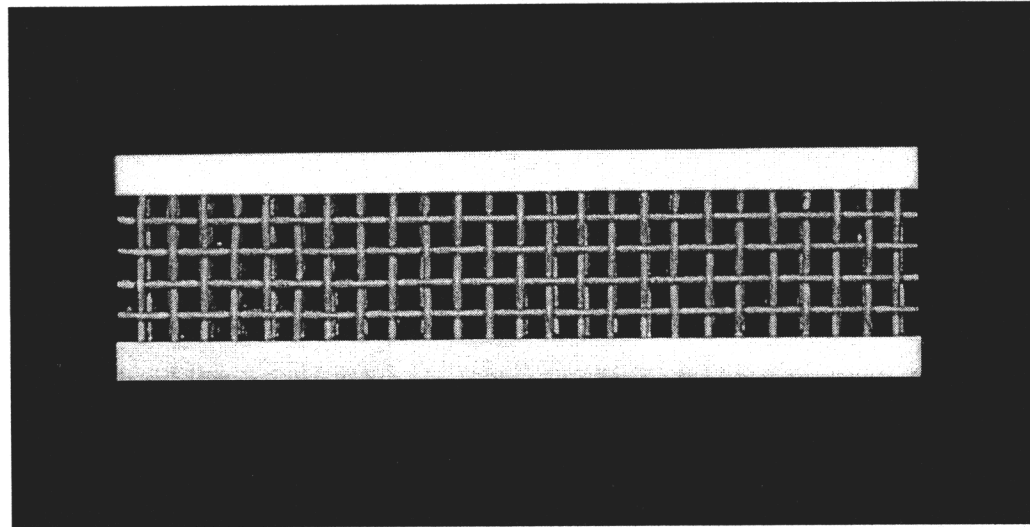





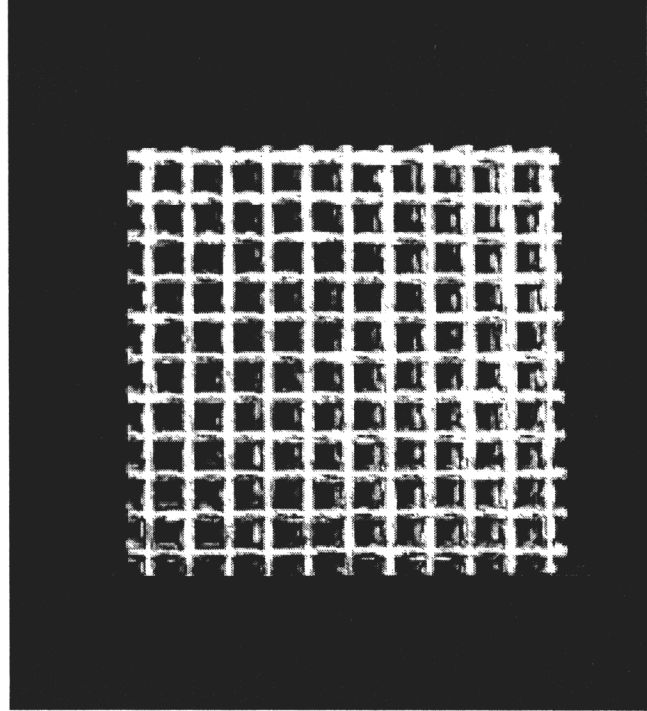
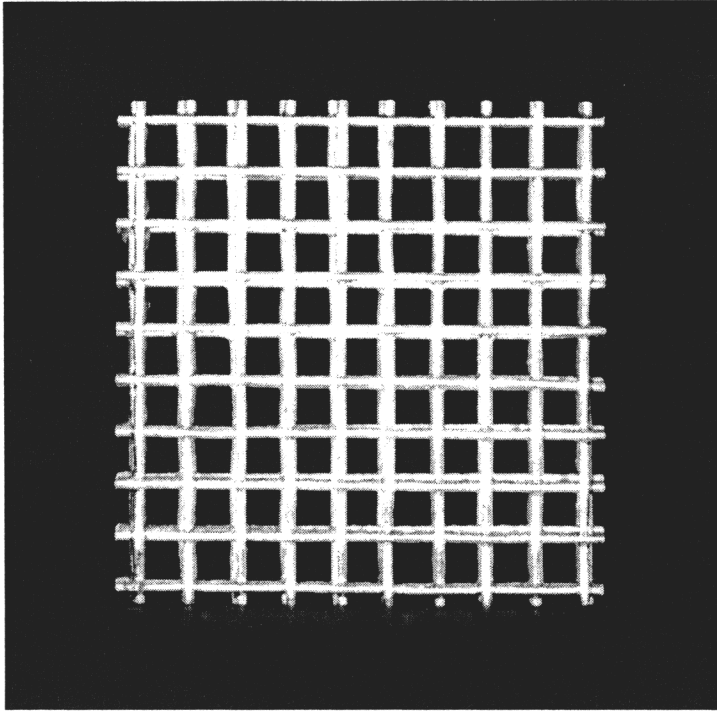

B-15a

# Materials Diversification

B-153

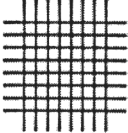
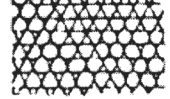
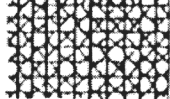

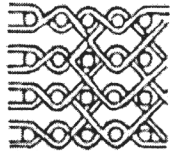
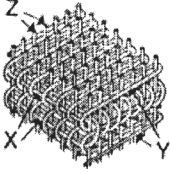
# Metal Textile Can Be Made In Many Forms

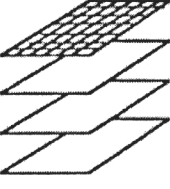
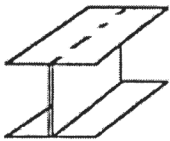
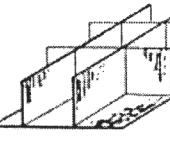
Dimension \ Axis		0	1	2	3	4 ~
		NON - AXIAL	MONO - AXIAL	BIAXIAL	TRIAxIAL	MULTI - AXIAL
1 D			 ROVING - YARN			
		 CHOPPED STRAND MAT	 PRE-IMPREG-NATION SHEET	 PLANE WEAVE	 TRIAxIAL WEAVE 1)-3)	 MULTI-AXIAL WEAVE, KNIT
3 D	Linear Element	 3-D BRAID	 3-D BRAID	 MULTI-PLY WEAVE	 TRIAxIAL 3-D WEAVE	 (MULTI-AXIAL 3-D WEAVE) 4)~n, 12)~14)
	Plane Element	 LAMINATE TYPE	 LAMINATE TYPE	 H or I BEAM	 HONEY-COMB TYPE	

B-154

## REFERENCE:

K. Fukuta, R. Onooka, E. Aoki and Y. Nagatsuka in S. Kawabata (Ed.), 15th Text. Res. Symp., The Textile Machinery Society of Japan, Osaka, 1984, pp. 36-38.

F.K. Ko, "Three Dimensional Fabrics for Composites", In Textile Structural Composites, edited by T.-W. Chou and F.K. Ko, pp.129-171, Elsevier, 1989.

# Sandwich Panel Wingskin

## For efficient support of bending and twisting loads:

- Space two stiff, strong skins far apart.
- The lightest core that still supports the necessary compressive and shear loads.
- Skins that are well bonded to the core.

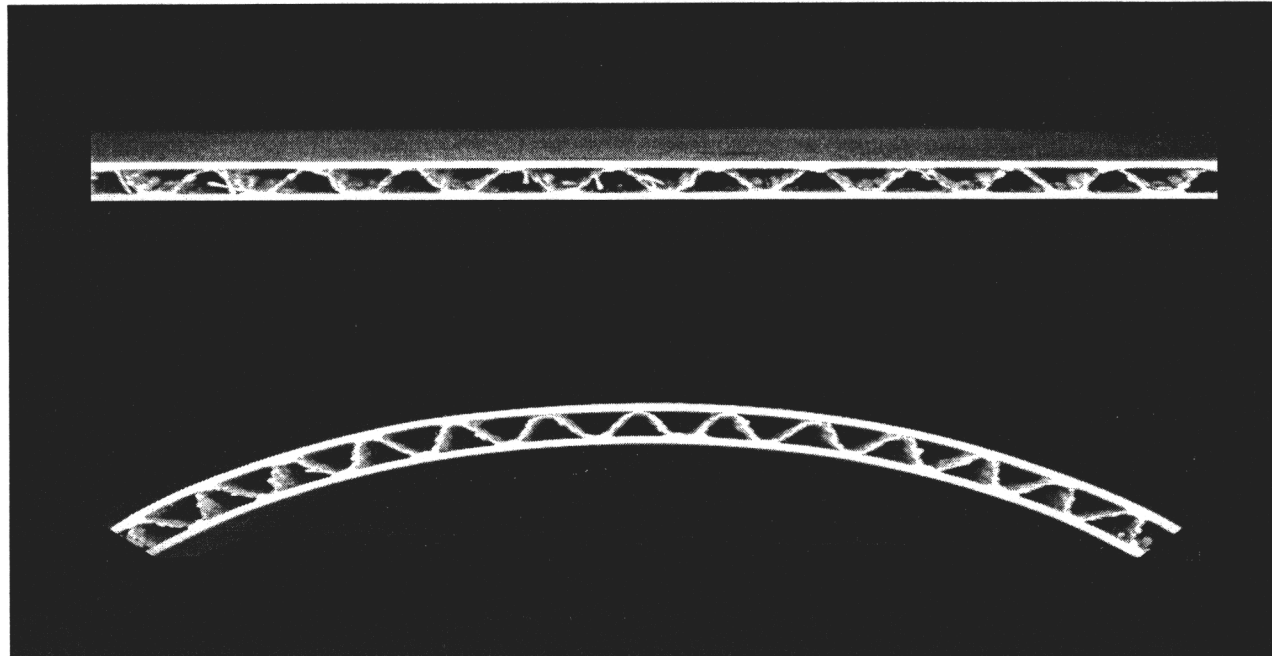

304 stainless steel  
Core relative density: 0.04  
Facesheet thickness: 0.61 mm

## Advantages:

- High fluid permeability, complex shapes, dent rather than crack, many materials choices, relatively inexpensive (\$11.64/ft<sup>2</sup>).
- Steel and Nickel alloys. Aluminum and titanium appear feasible.

B-155

# Supersonic Airfoil Issues

## Open Cell Metal Core Sandwich Panel Wingskins

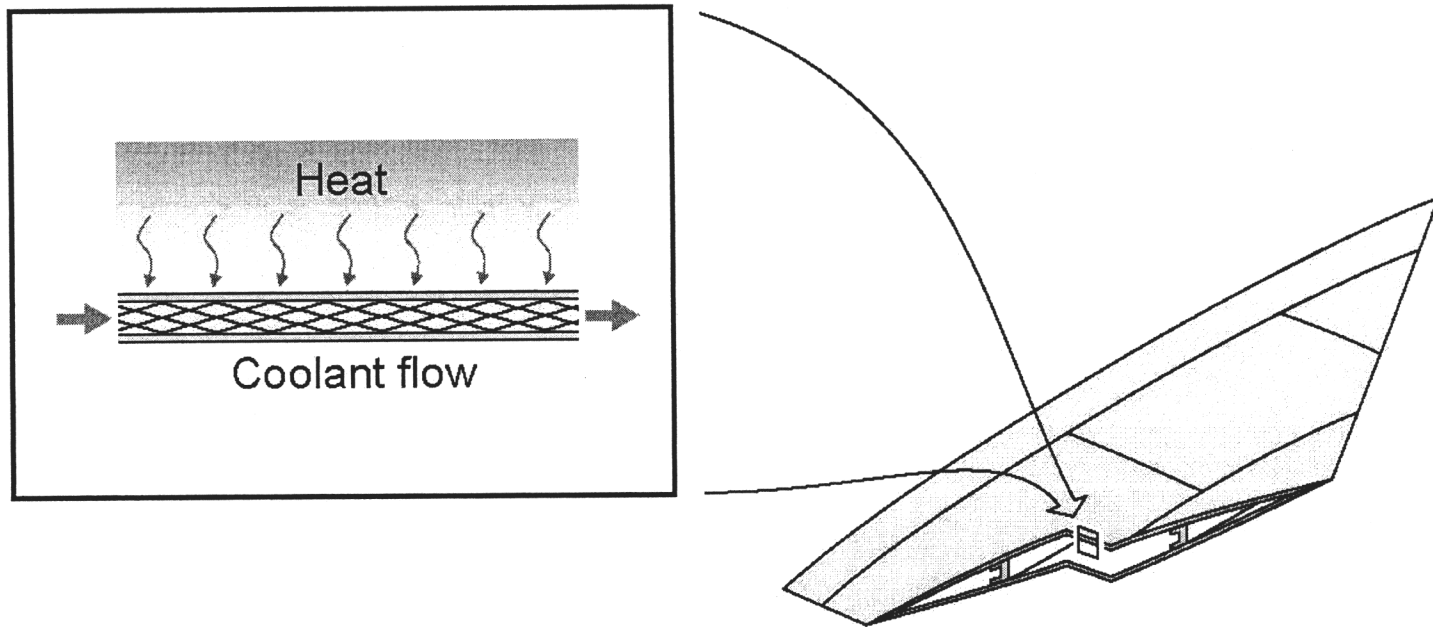

B-156

# Constructed Cellular Metals

**University of Virginia (Sypeck/Wadley)**

**Process:** pressing of expanded/perforated metal + transient liquid phase bonding

**Materials:** aluminum 6061, stainless steels, titanium alloys, Ni-Base superalloys, copper alloys (ductile materials).

B-157

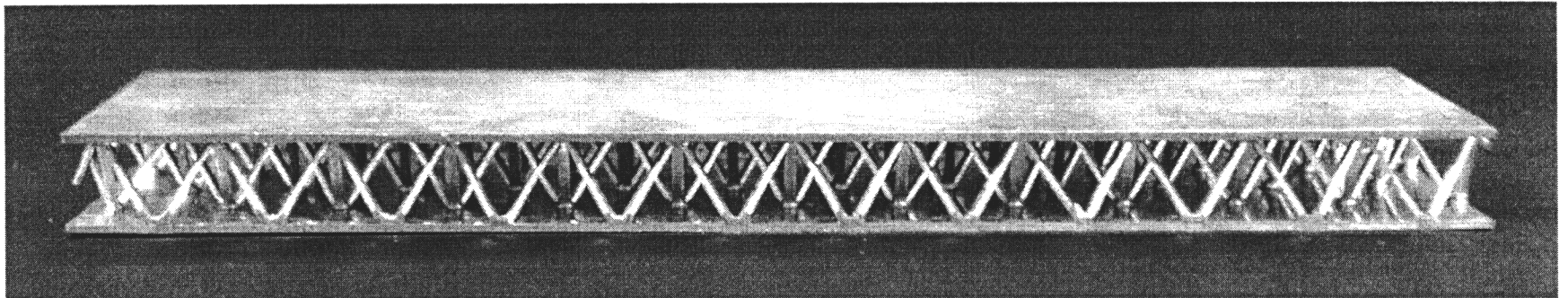

**Cell Size: 2-50mm**

**$\rho/\rho_s$ : 1-10%**

# Periodic Truss Cores

Hexagonal perforated sheet

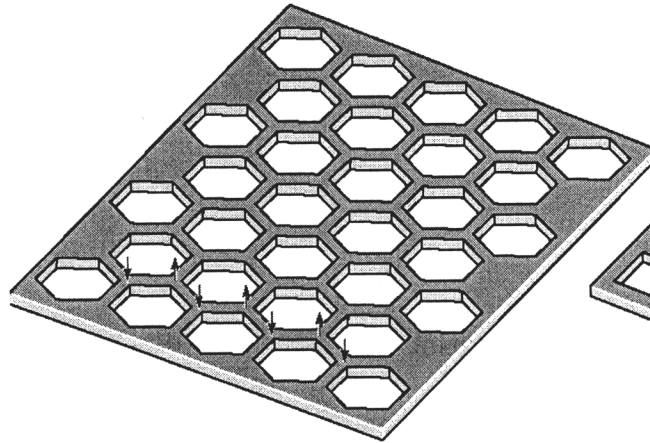

Square perforated sheet

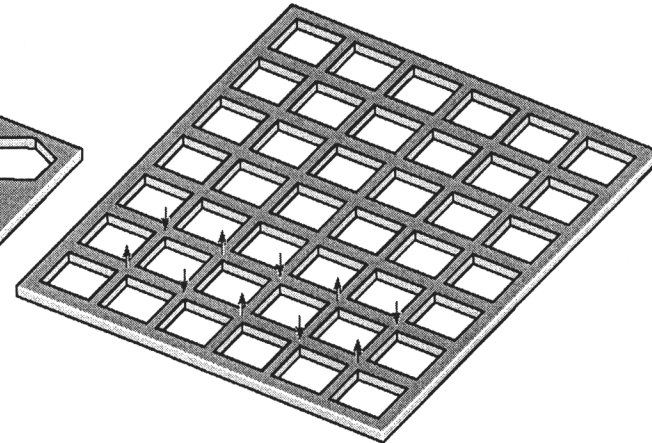

Intersections to be shaped out of plane

Tetrahedron Truss

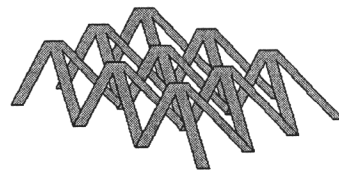

Pyramidal Truss



# Wrought Stainless Steel Tetrahedral Truss

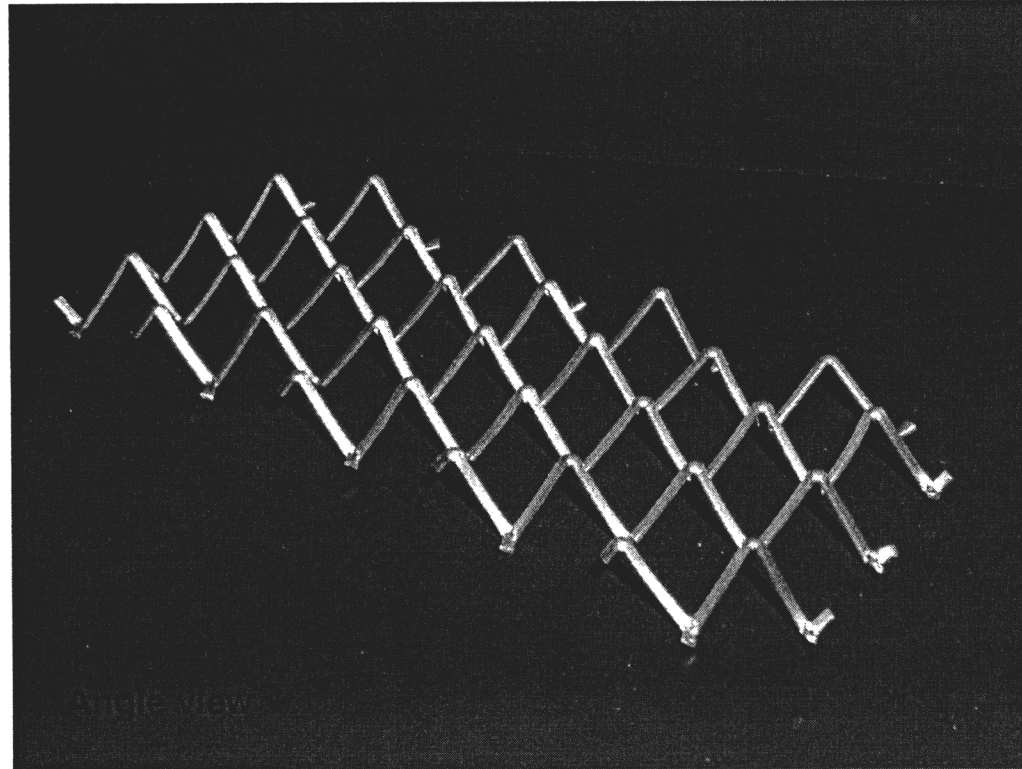

B-159

Material: 304 stainless steel  
Tetrahedron height: ~9 mm  
Relative density: ~2%

Leg width: ~1.25 mm  
Leg thickness: ~0.57 mm

Other Materials: Al alloys (6061, 6951, 3003, 1100), titanium alloys, copper, nickel alloys, . . .

# Sandwich Panel Construction Techniques

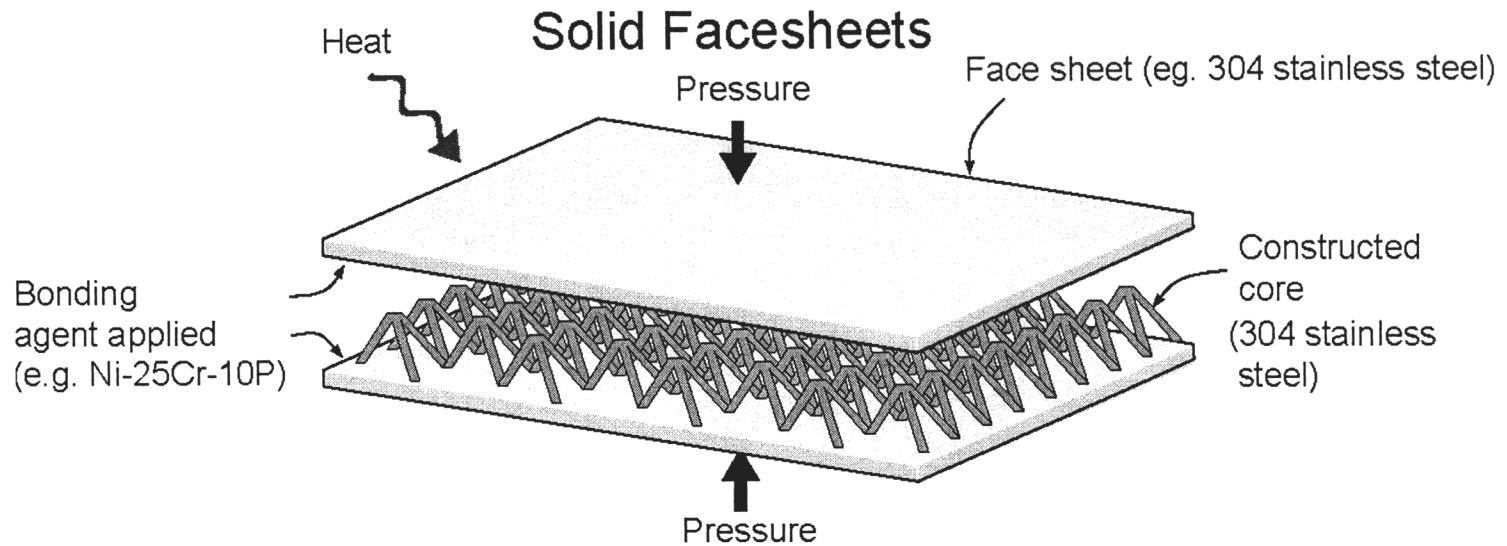

## Expanded Facesheets

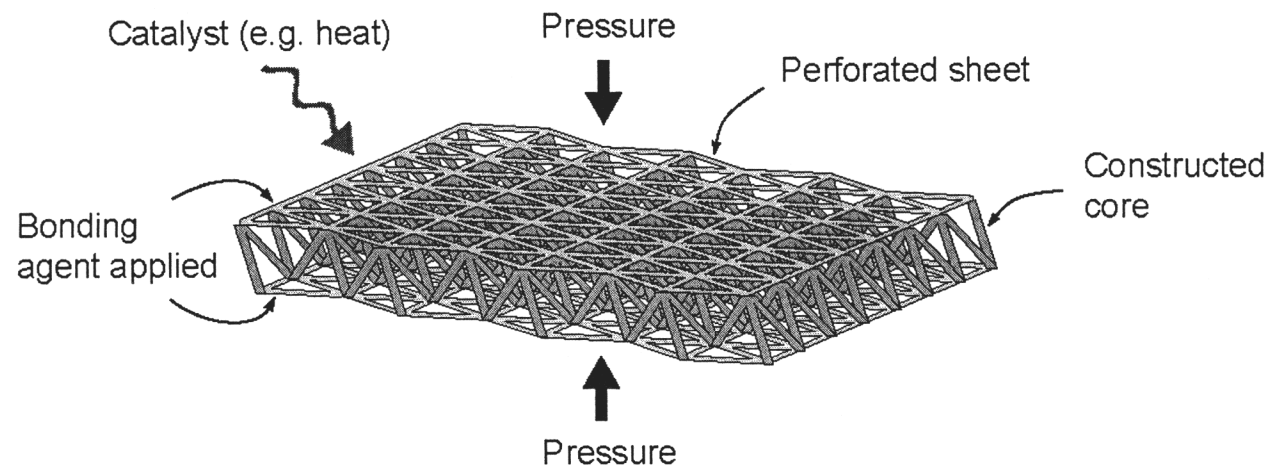

B-160

# Constructed Truss Structure Failure Mechanisms

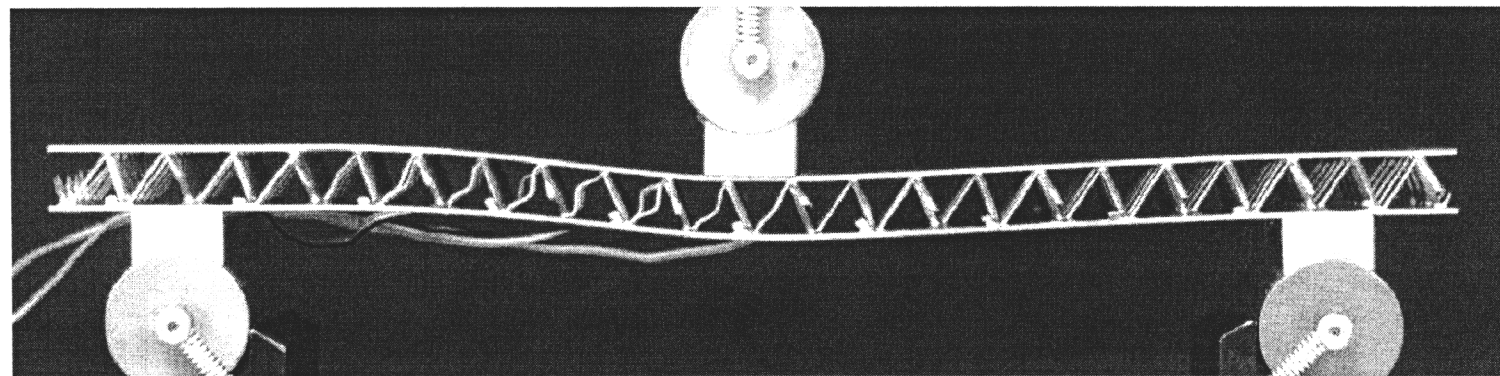
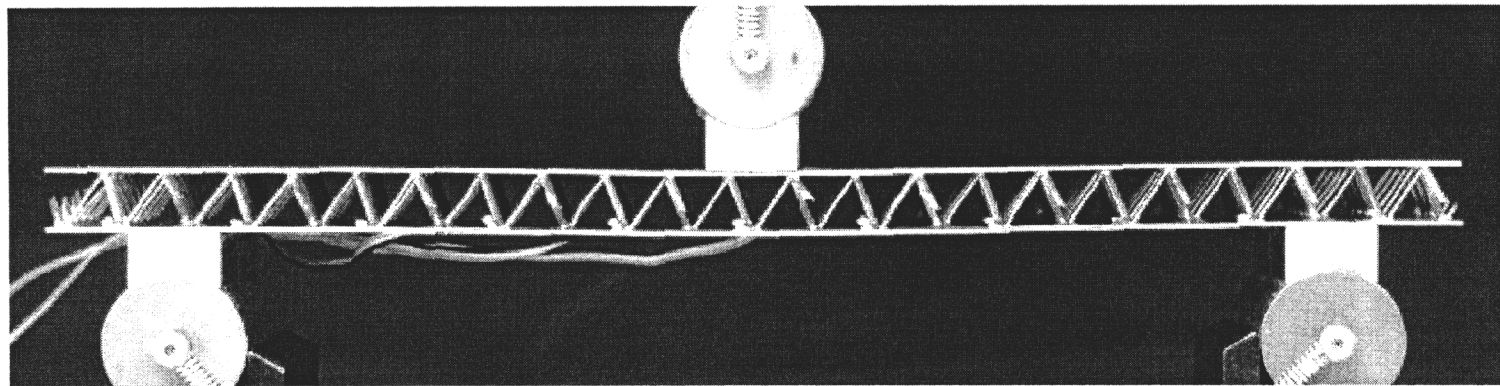
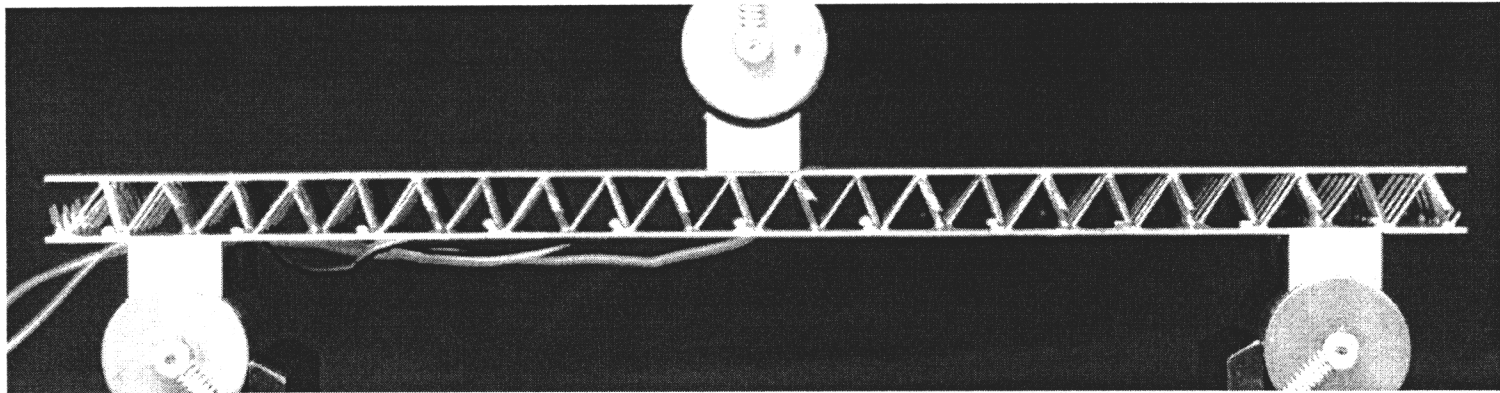

13-161

# Constructed Cellular Solid Load Response: 3-Point Bending

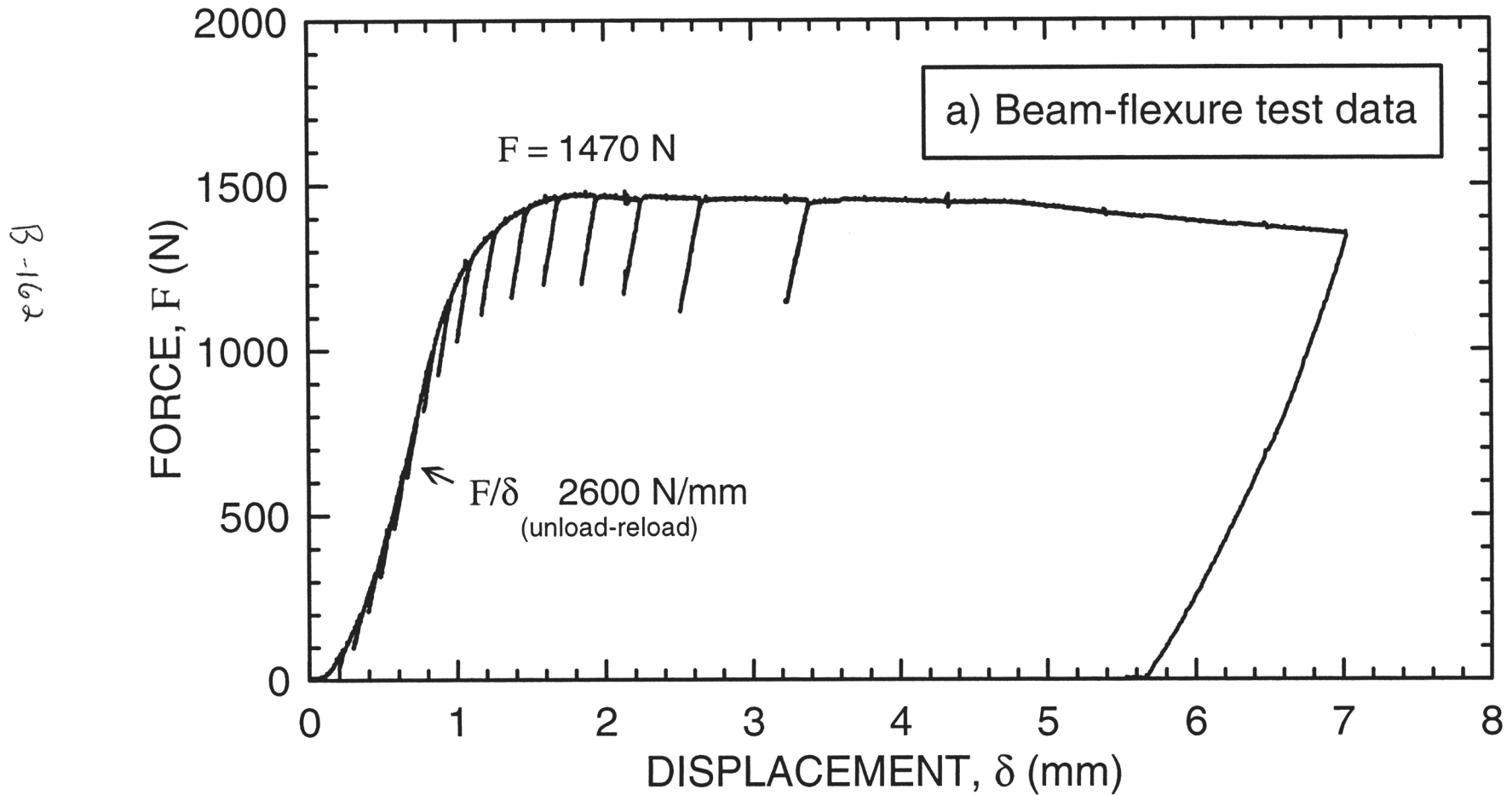

# Constructed Cellular Solid Property Comparisons

13-163

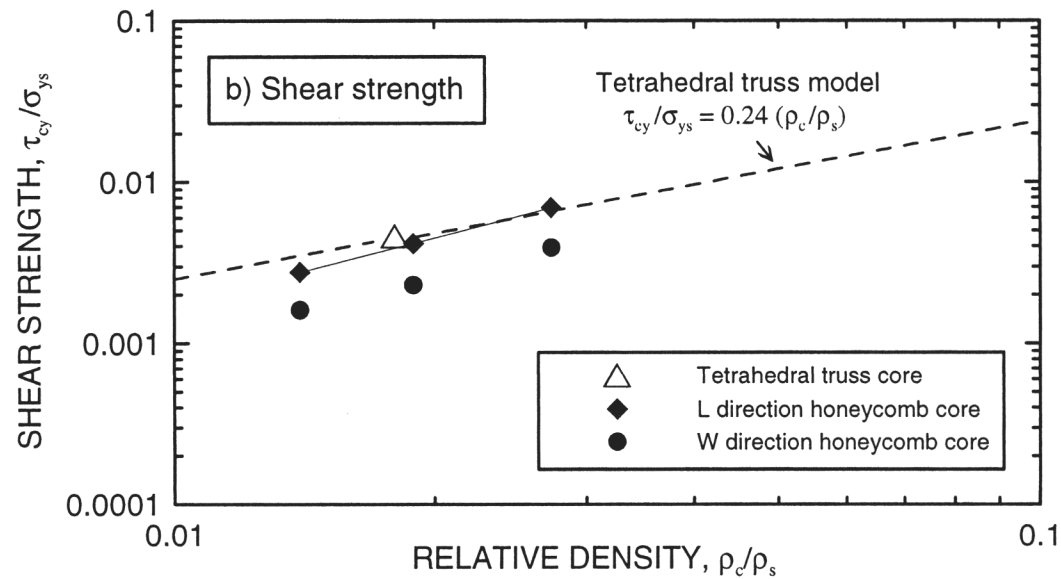
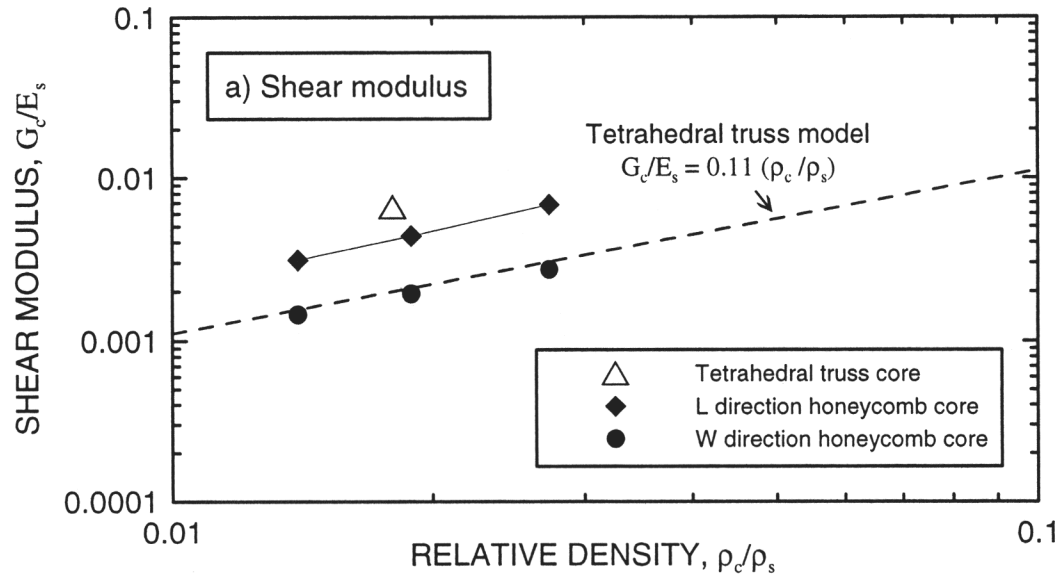

# Tetrahedral Truss Core / Hexagonal Facesheets

B-164

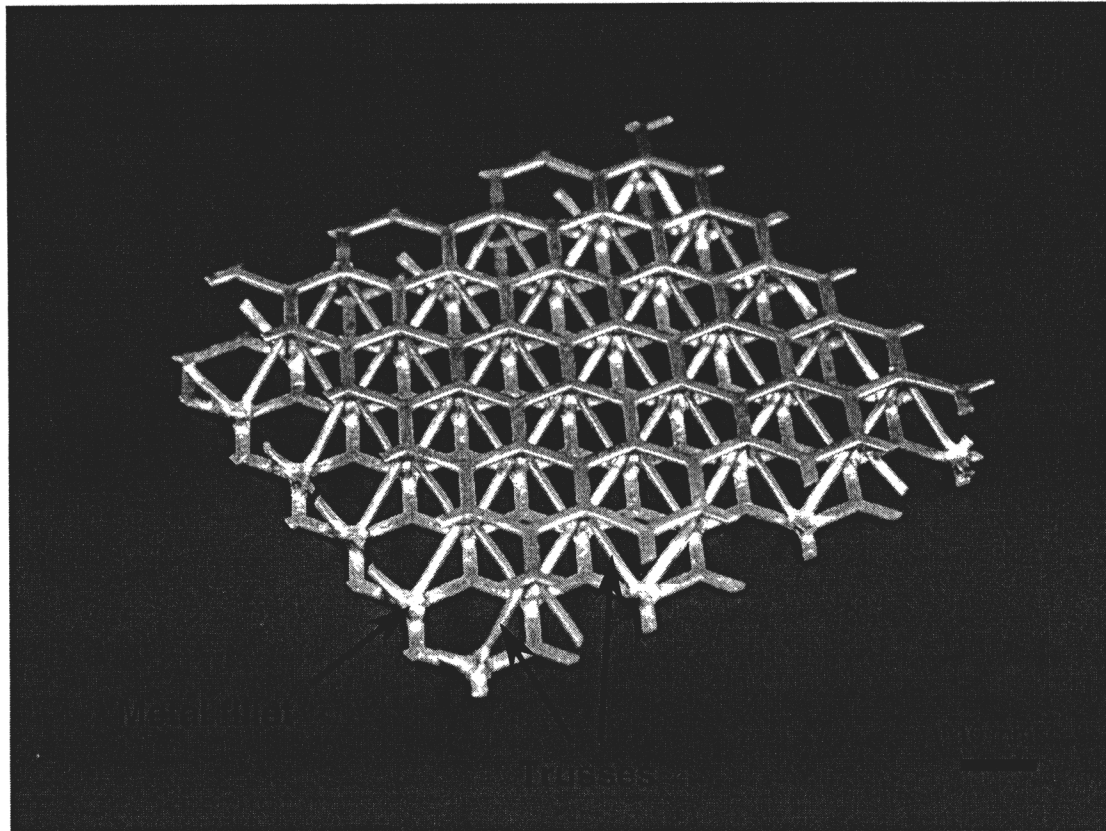

# Electro-Deposited Truss Structures

## Microcontact Printing ( $\mu$ CP)

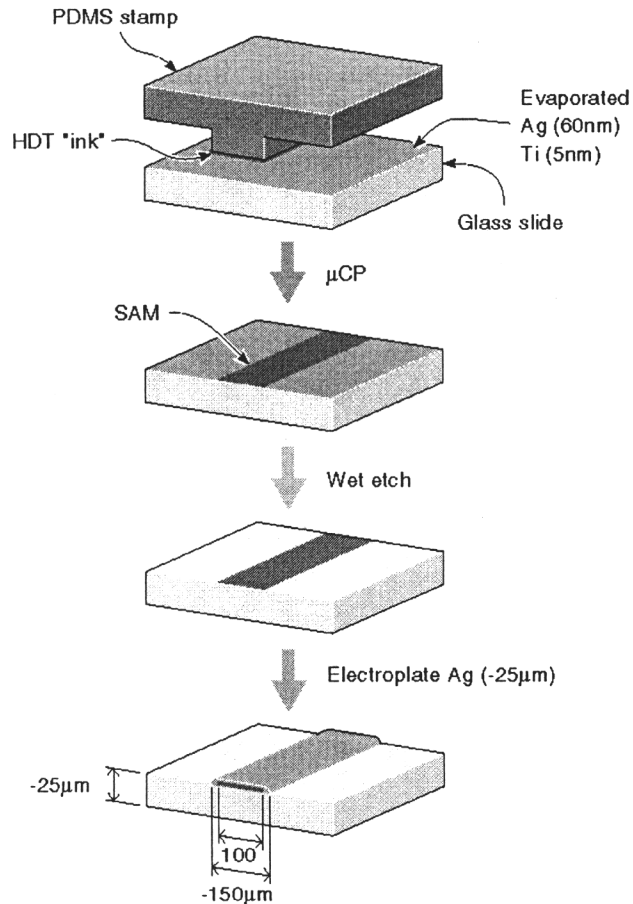

## Truss Pressing / Assembly

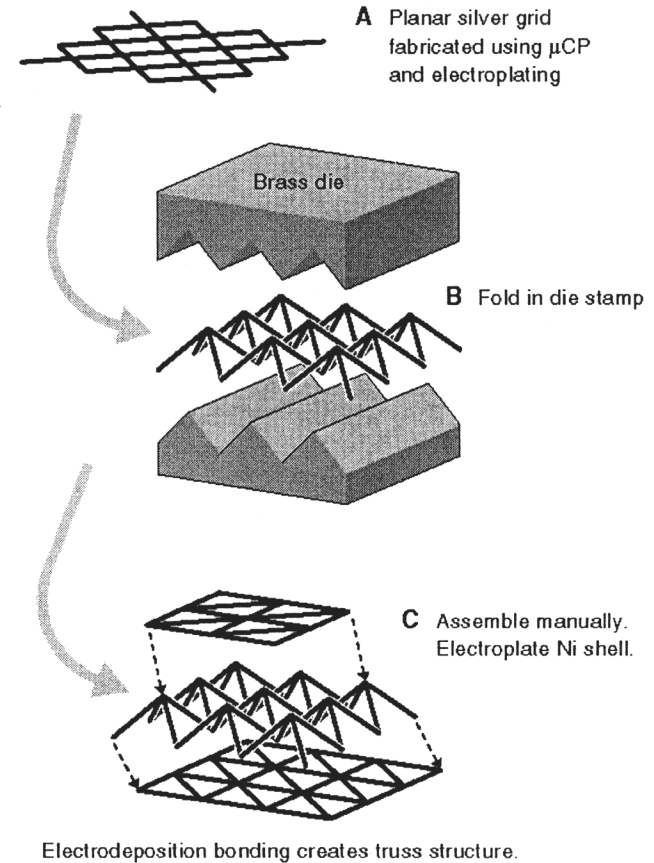

2582\_electrodeposit\_truss\_al h wadley ipm 6/2001

B-165

# Electro-Deposited Microtruss Structures

Harvard (Whitesides, Britain, Sugimura, Schueller, Evans)

Process: soft lithography (MCP), Electrodeposition

Materials: Copper, Nickel

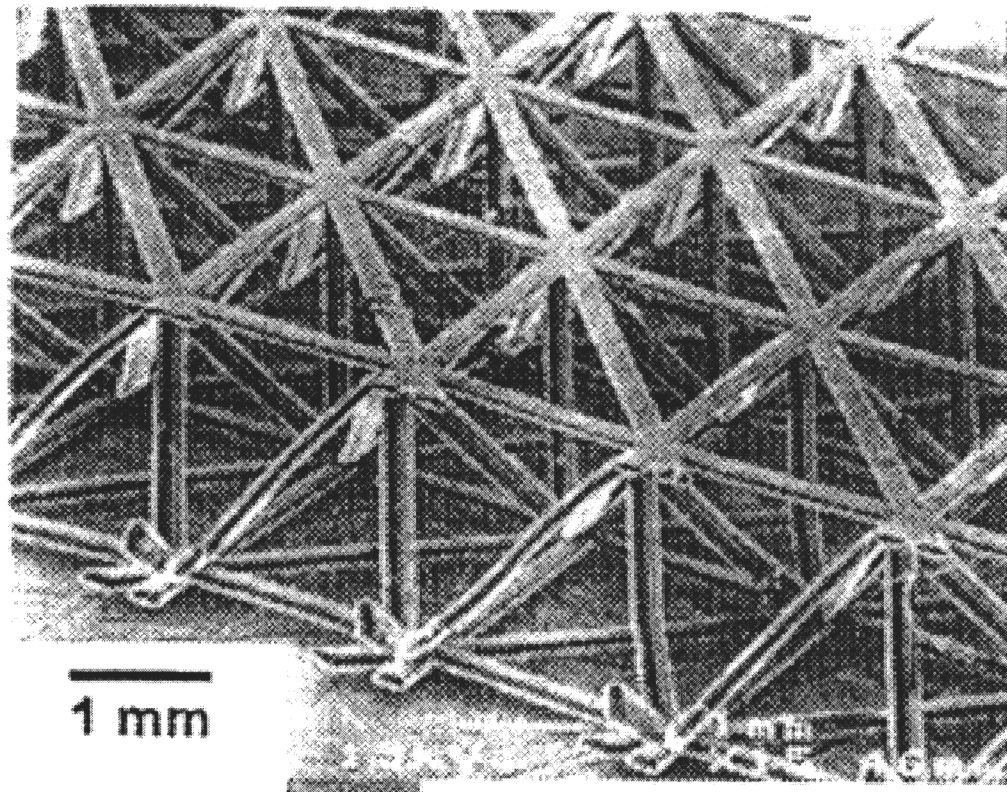

13-166

# Prismatic Cellular Metals

B-167

# Extrusion of Metal Precursors

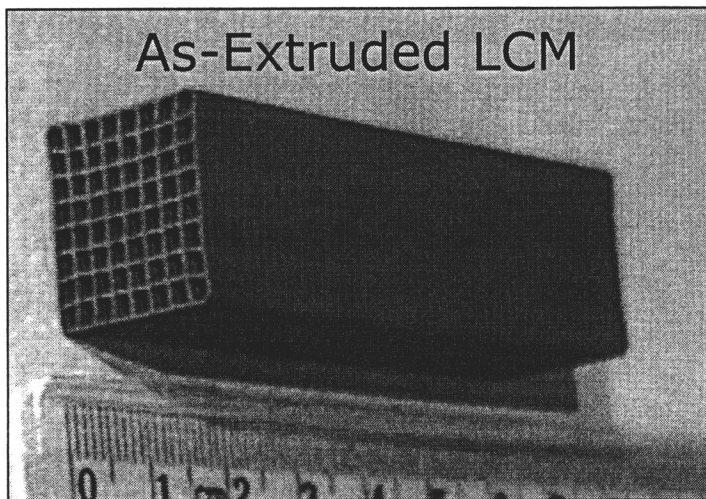

Reduction  
→  
& Sintering

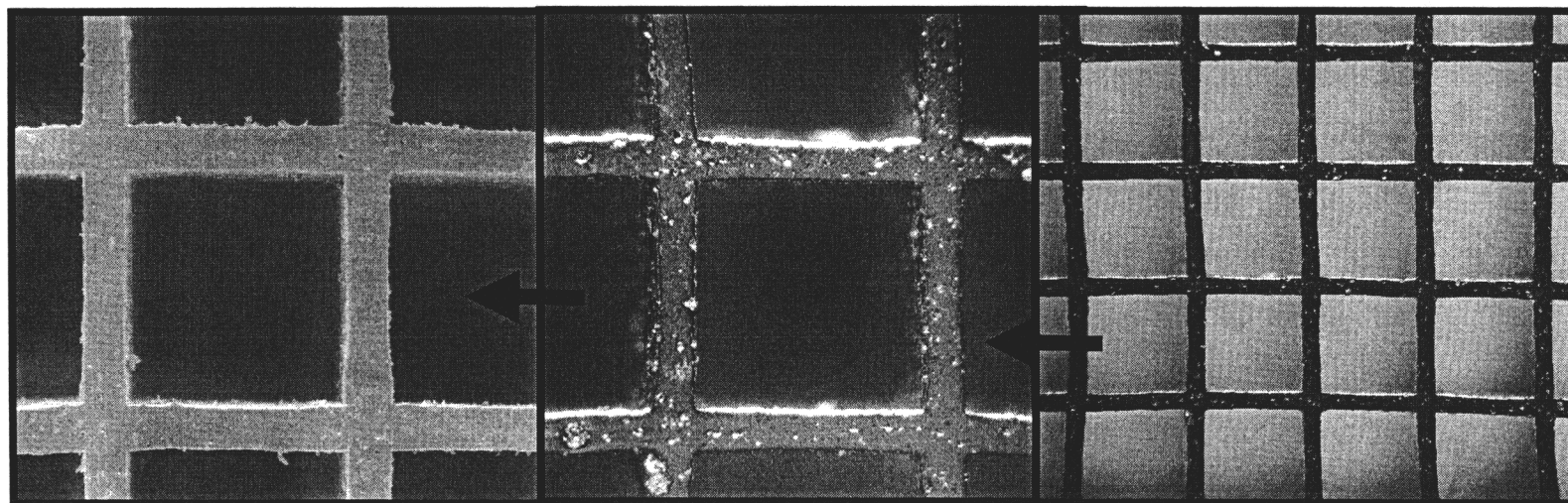
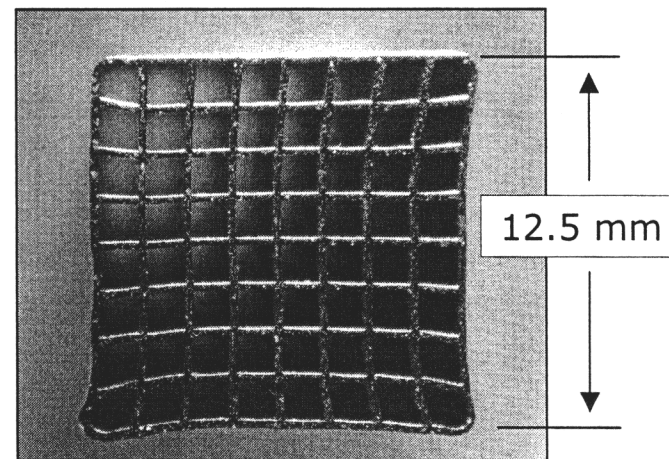

SEM Micrograph

Front Lighting

Back Lighting

8-168



# Oxide Powders Transformed into Metal Linear Cell Structures



13-169

Step One  
Paste Preparation

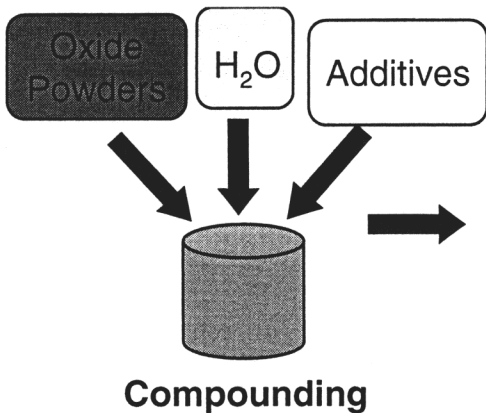

Step Two  
Shape Fabrication

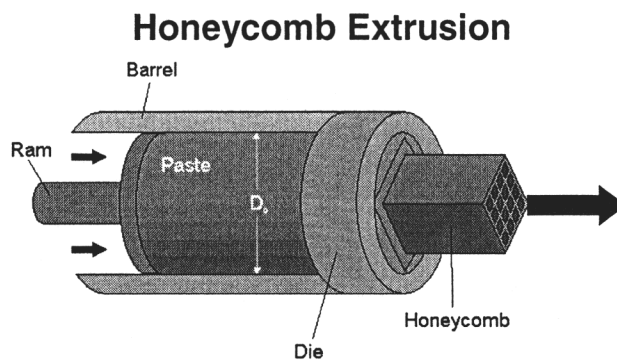

Drying

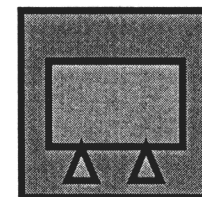

Flexible Die Design

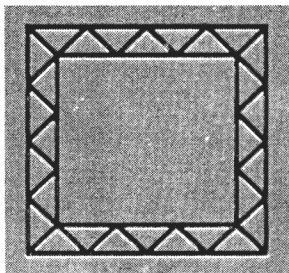

Step Three  
Direct Reduction

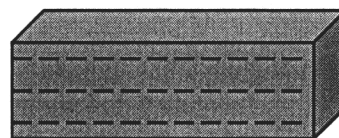
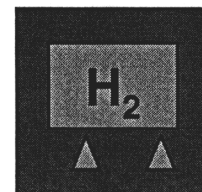

Finished Metal Part

Direct Reduction



# Material Compositions

## Maraging Steels

Fe 18Ni 12Co 4Mo 1.5 Ti

from  $\text{Fe}_3\text{O}_4$ , NiO,  $\text{Co}_3\text{O}_4$ ,  $\text{MoO}_3$ ,  $\text{TiH}_2$

Reduction = Hydrogen at 1350 °C

- Ni Alloy - "617"

22Cr 55Ni 12Co 9Mo from  $\text{Cr}_2\text{O}_3$ , NiO,  $\text{Co}_3\text{O}_4$ ,  $\text{MoO}_3$

- Copper

Cu, Cu 1Ni, Cu 3Ni, Cu 8Ni, Cu 3Ag from  $\text{Cu}_2\text{O}$ , NiO, AgO

- Inconel reduction process ("718") \*



\*Weight Ratios

B-170

# Summary

- Many methods for manufacturing cellular metals are available. They result in either stochastic or periodic cellular metals.
- The properties of cellular metals depend upon the (structure/properties) of the material in the ligaments AND the metal topology. Foaming processes lead to inefficient load supporting topologies. Alloy design science may improve ligament properties.
- Many methods for manufacturing periodic cellular metals are emerging. Some are likely to be cost competitive with foaming (much superior to Honeycomb).
- Periodic structures may be superior for sandwich panel structures and multifunctional heat exchangers.

# Cellular Metal Manufacturing – Liquid Route

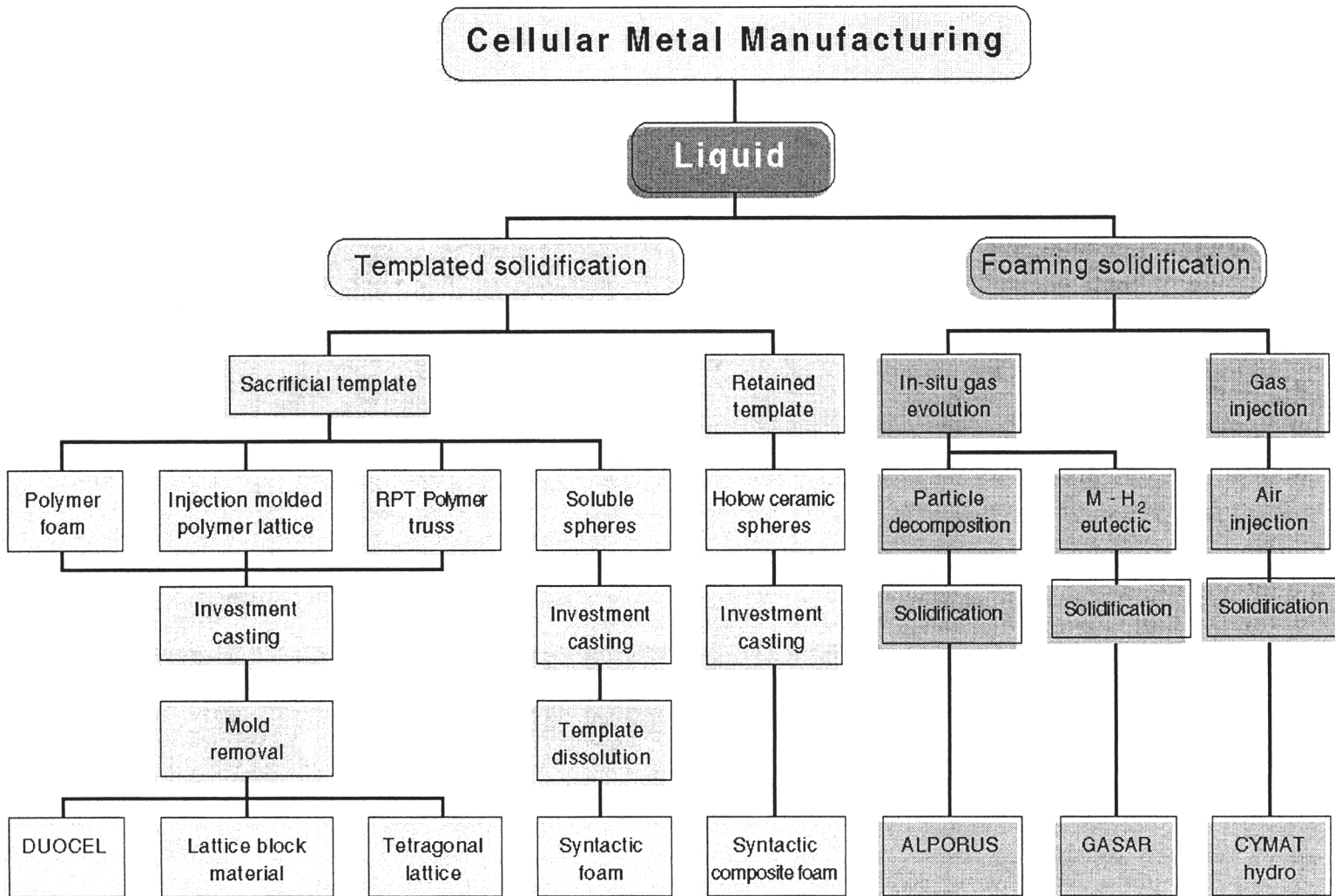

B-17a

# Cellular Metal Manufacturing – Solid

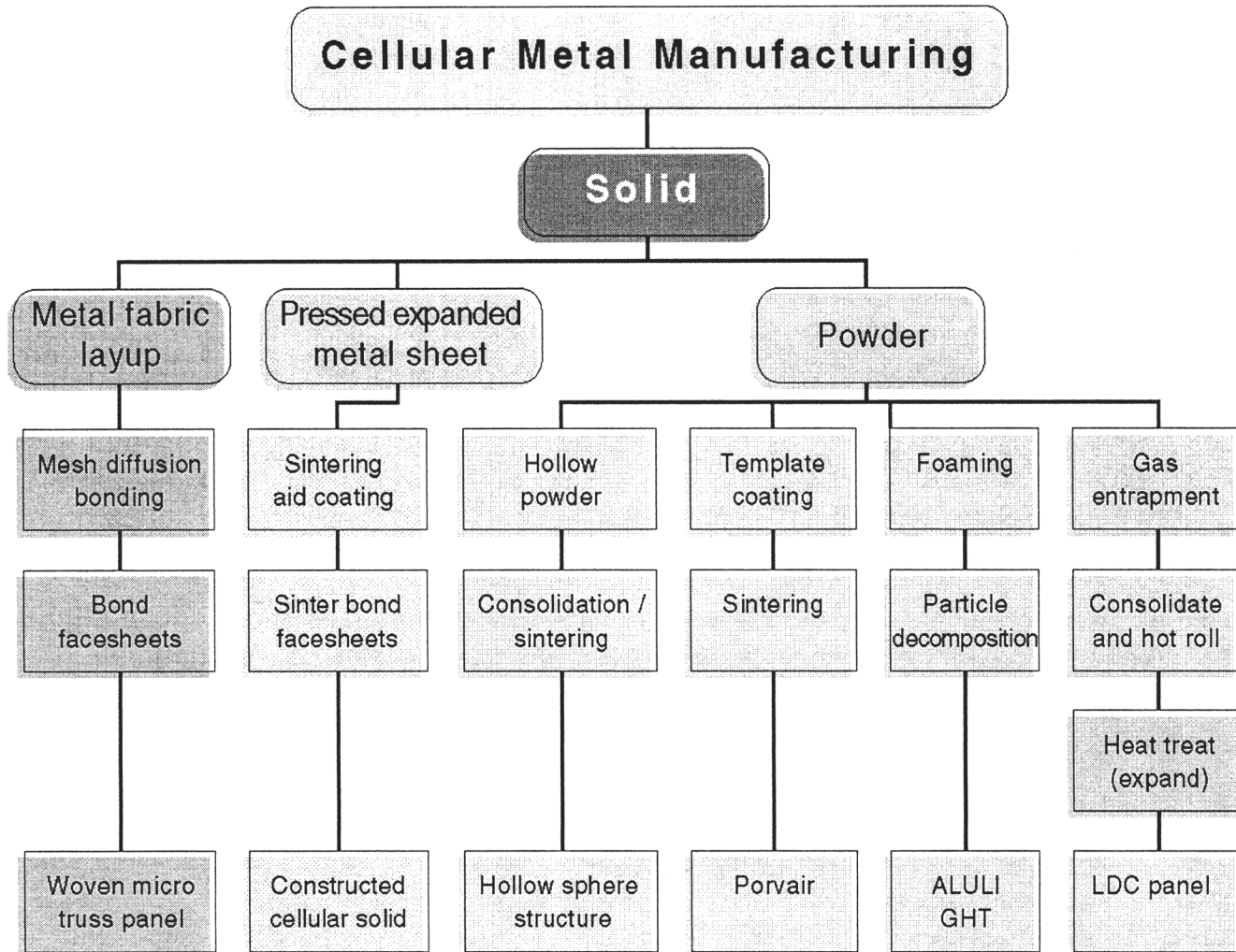

B-173

# Cellular Metal Manufacturing – Vapor

Cellular Metal Manufacturing

Vapor

Templated condensation

Polymer foam

DVD

CVD

Sinter.

Sinter.

DVD  
foam

INCO  
foam

13-174

# Cellular Metal Manufacturing

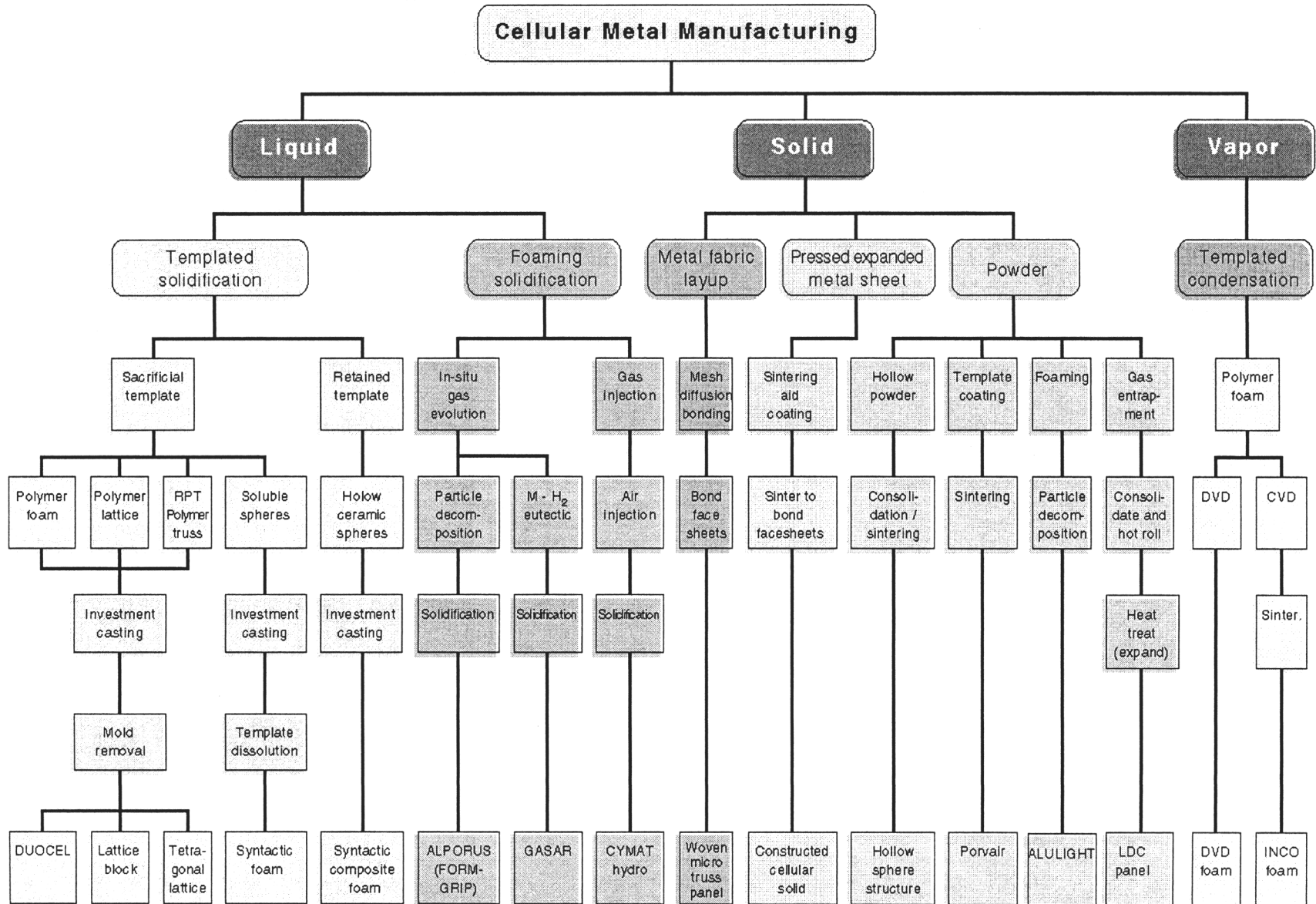

B-175

# Textile-Based Methods

a) Wire mesh

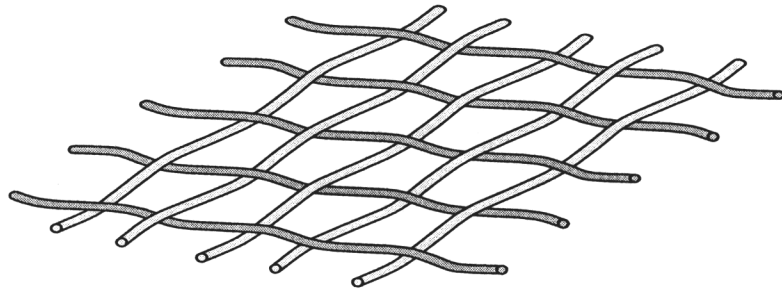

b) Corrugation

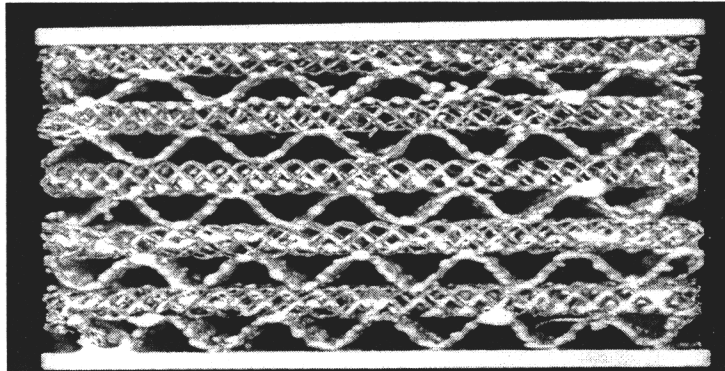
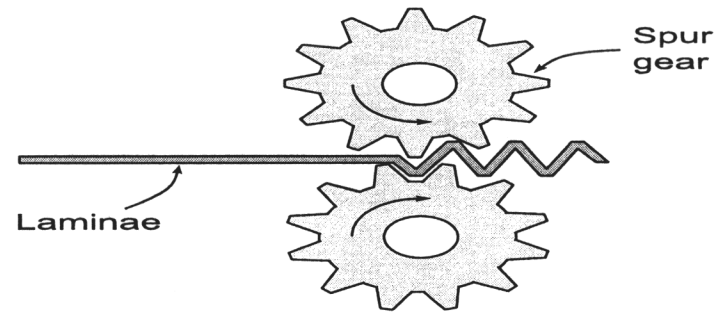

13-176

**ANTHONY EVANS  
PRINCETON UNIVERSITY  
PRINCETON MATERIALS INSTITUTE**

**DESIGNING WITH MATERIALS**

B-177

# TWO CATEGORIES OF TOPOLOGY

Stochastic

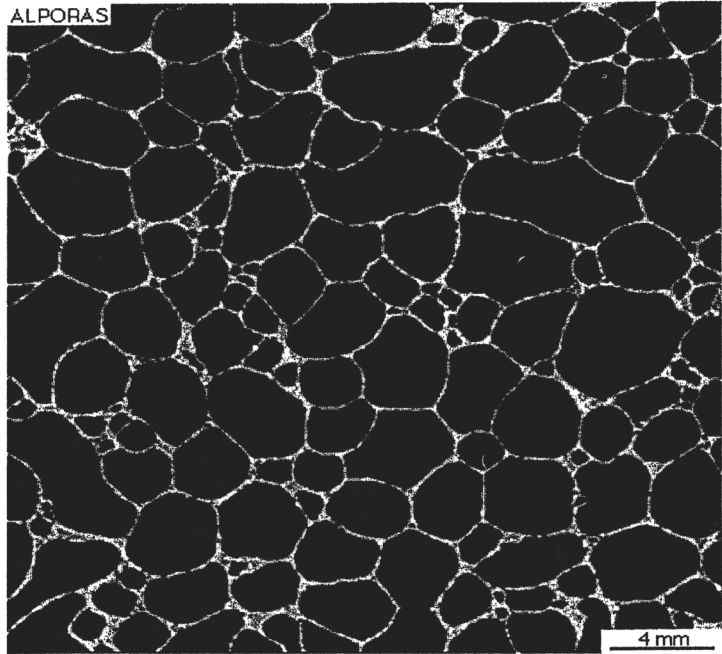

Periodic

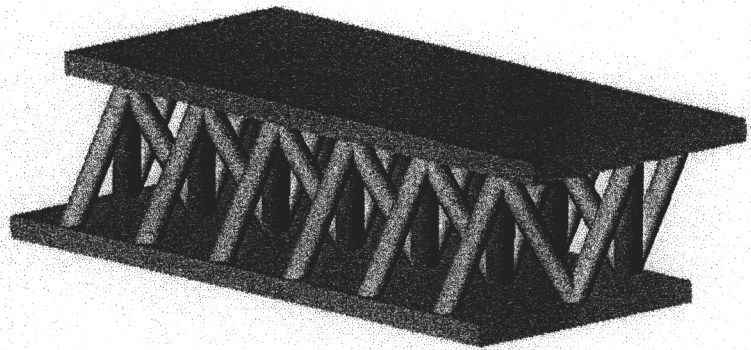

**a** TETRAGONAL Truss

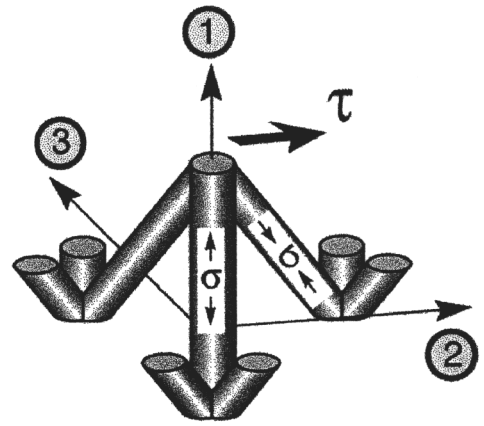

**b** PYRAMIDAL Truss

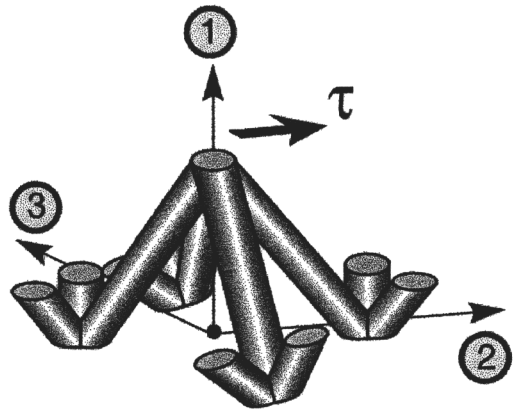

**c** PLAIN WEAVE DIAMOND PANEL

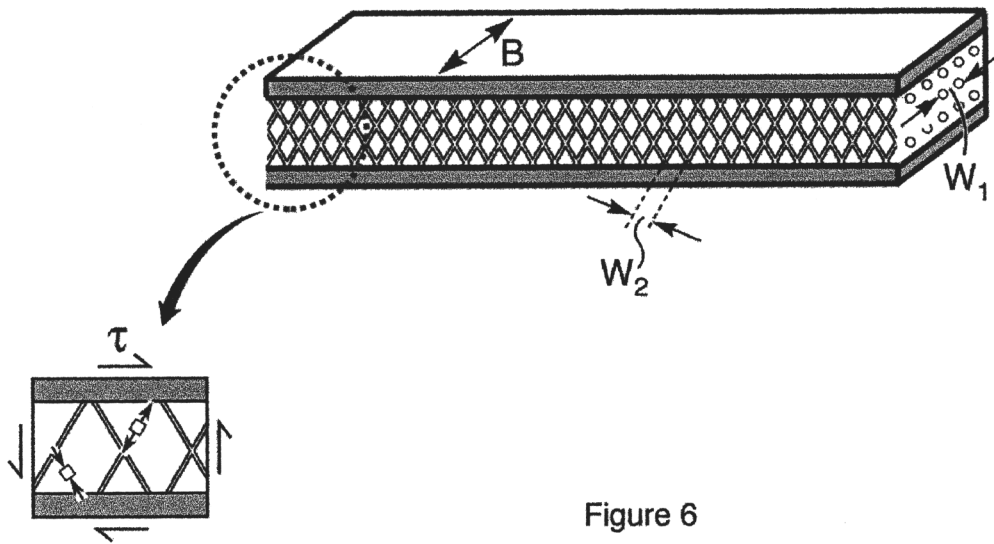
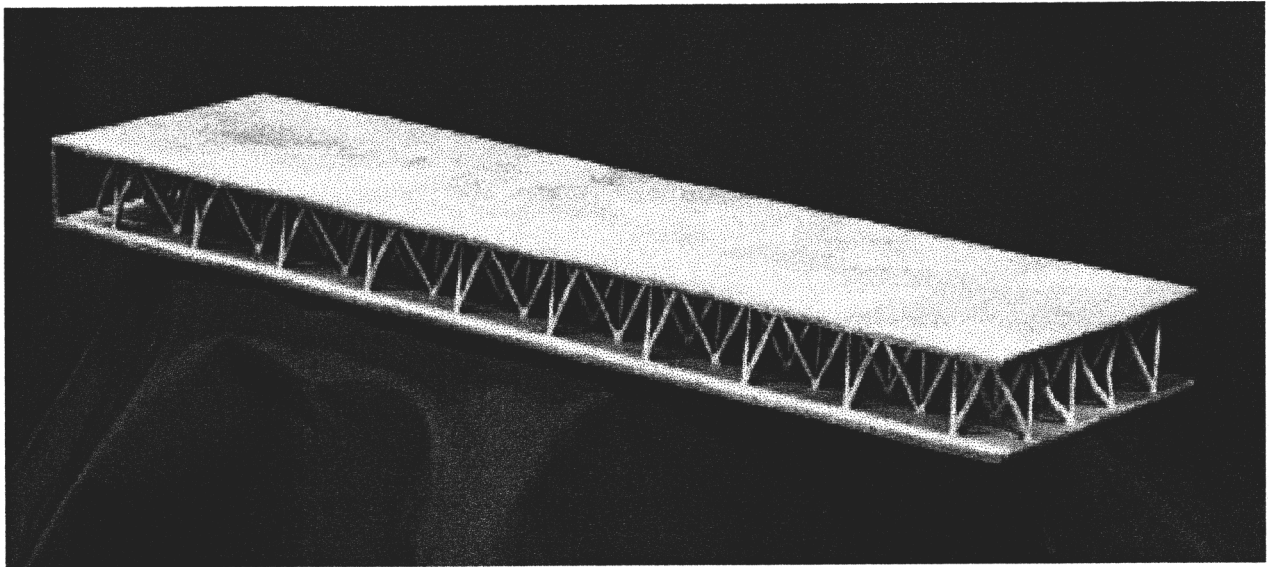

Figure 6

MRS Multifunctional.Fig.#6.

# Be-Cu Investment Castings (Cu-2.0 wt% Be)



(a) Strut diameter = 1.25 mm (optimum design)

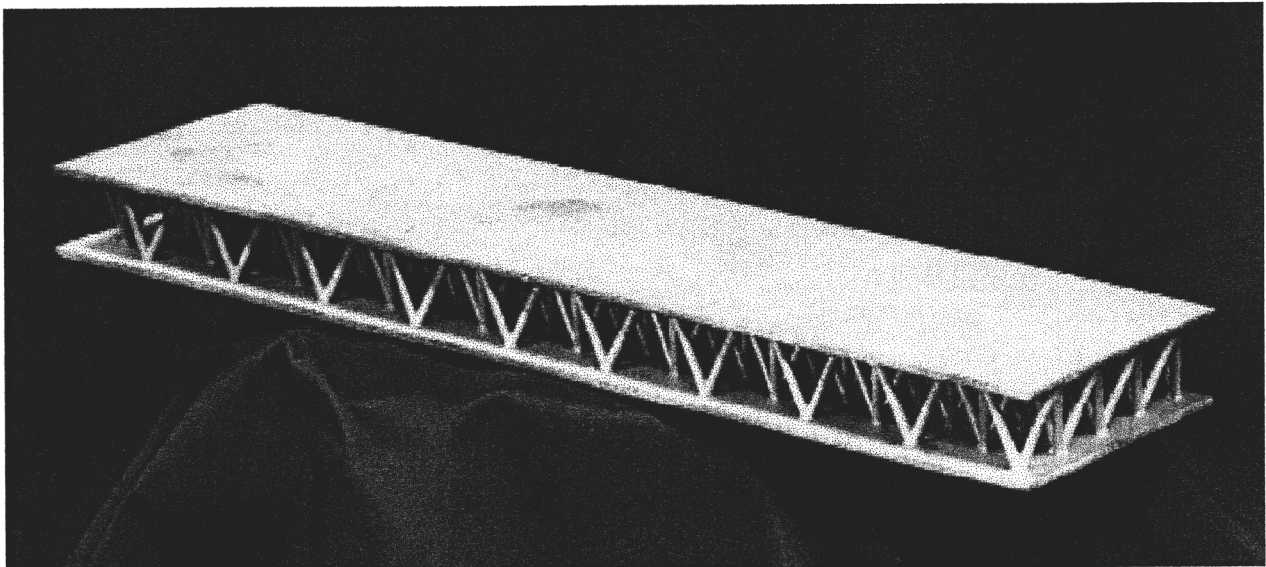

(b) Strut diameter = 2 mm (sub-optimal design)

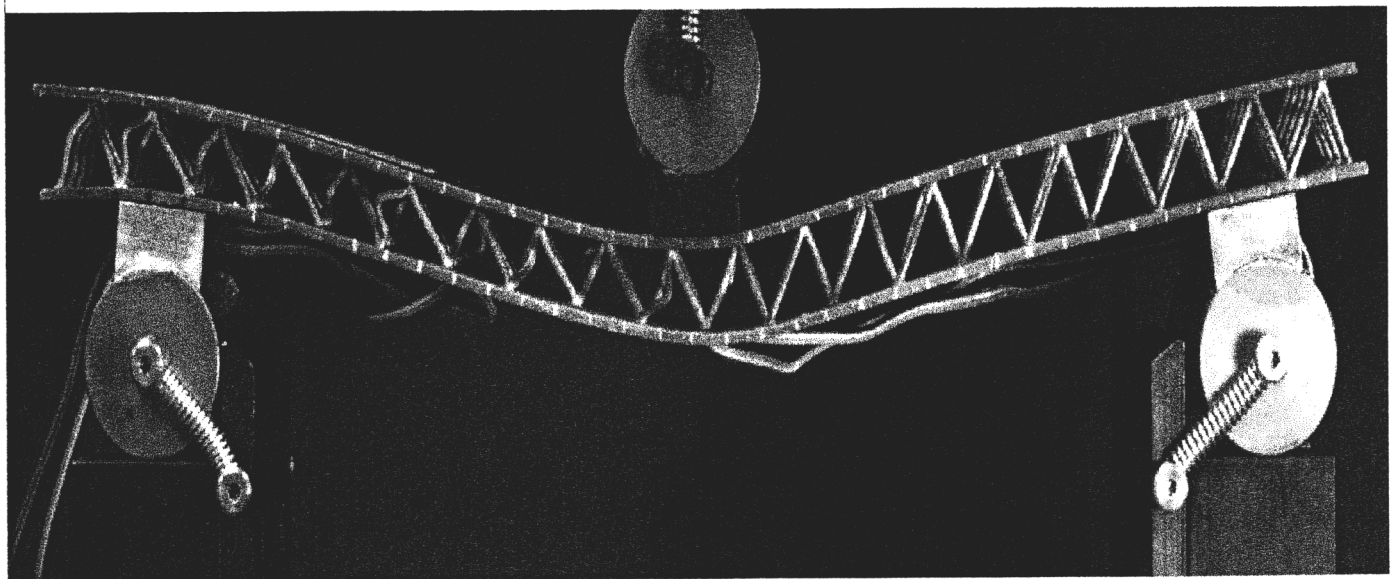
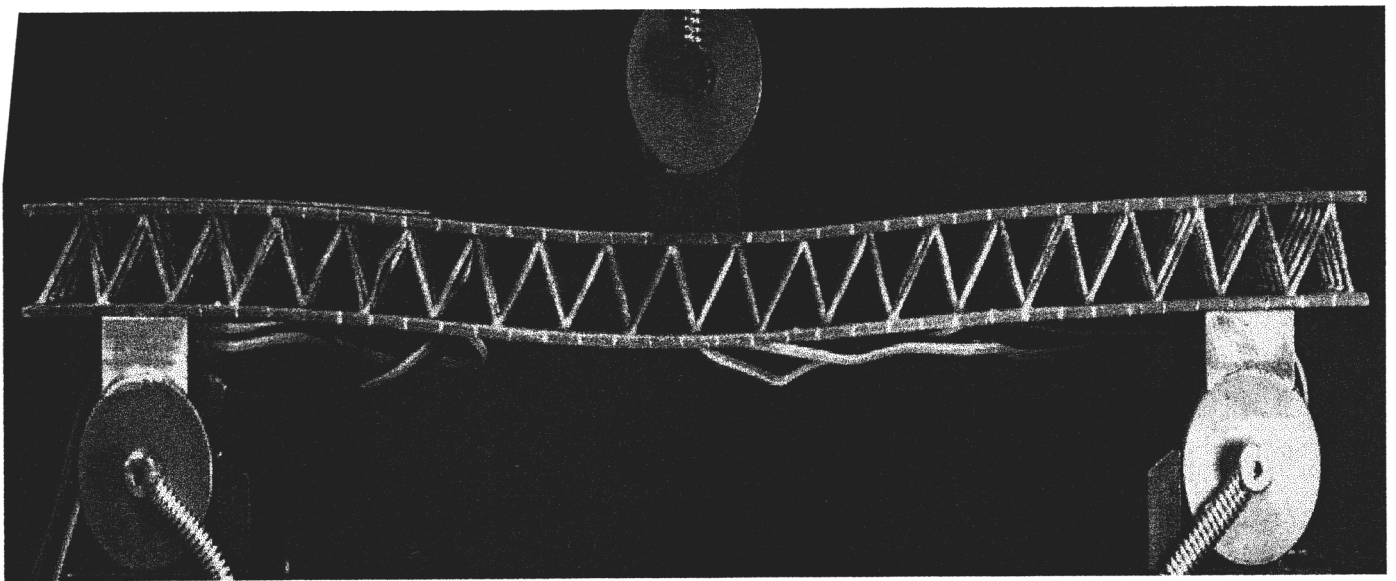
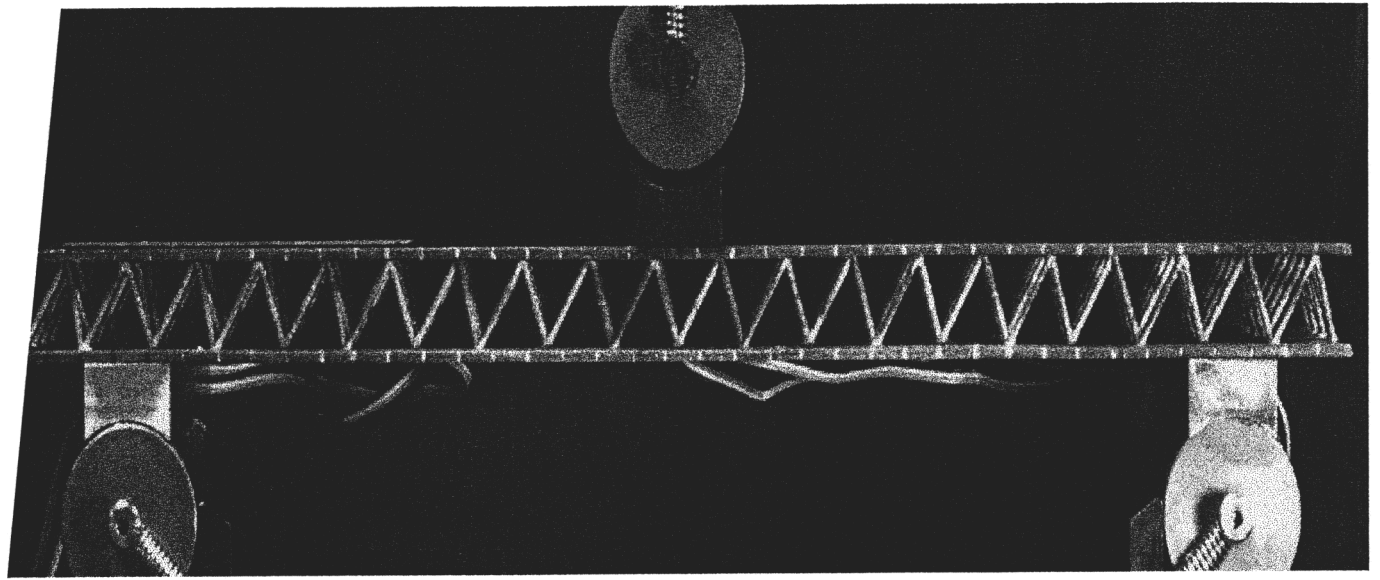

B-181

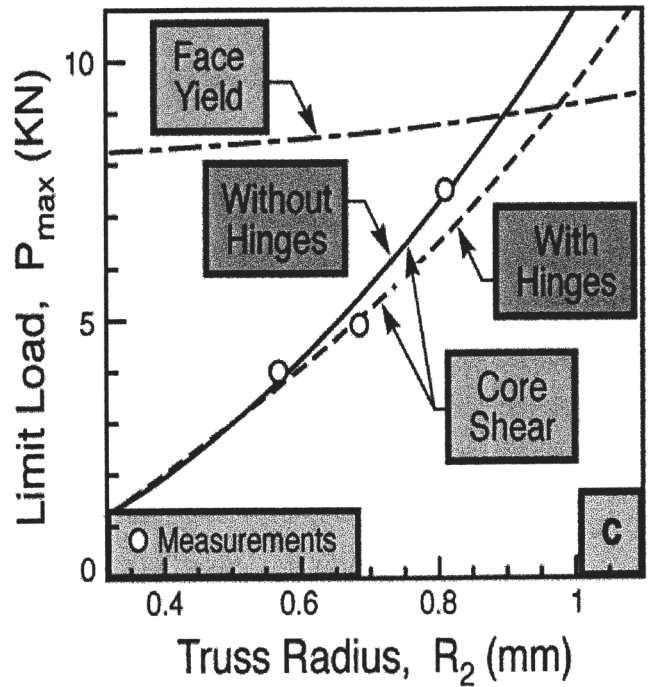
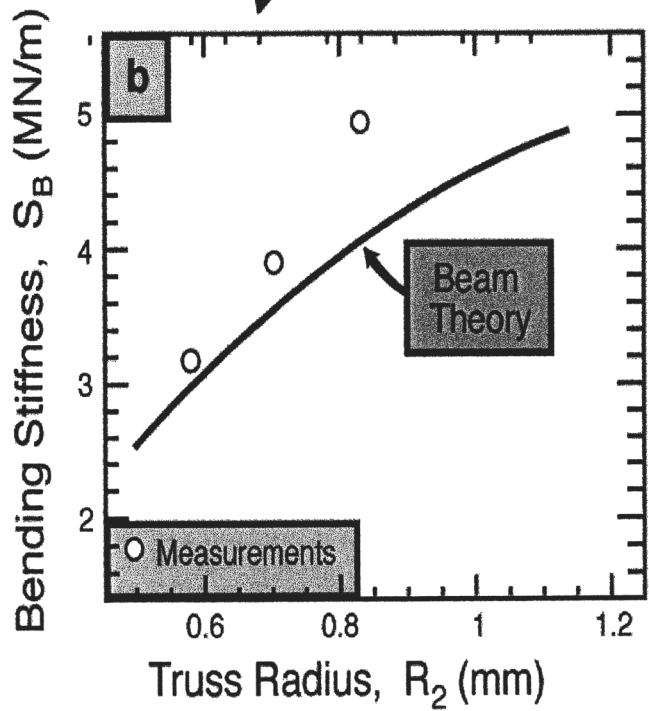
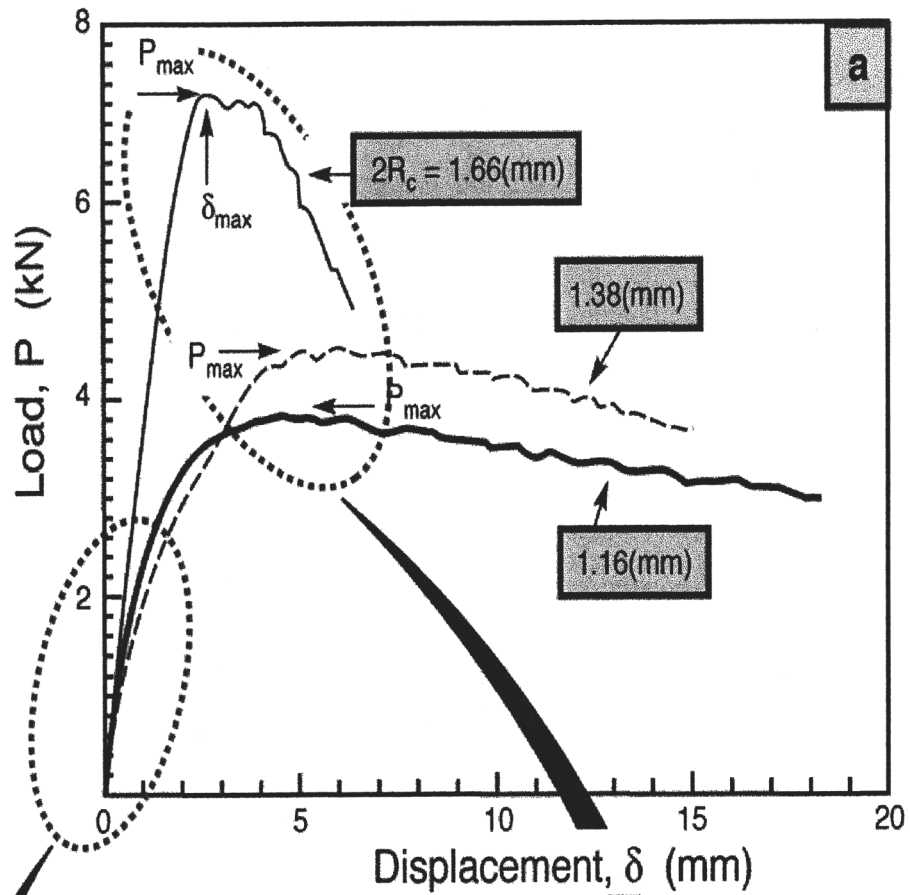

# PLATE BENDING COMPARISON

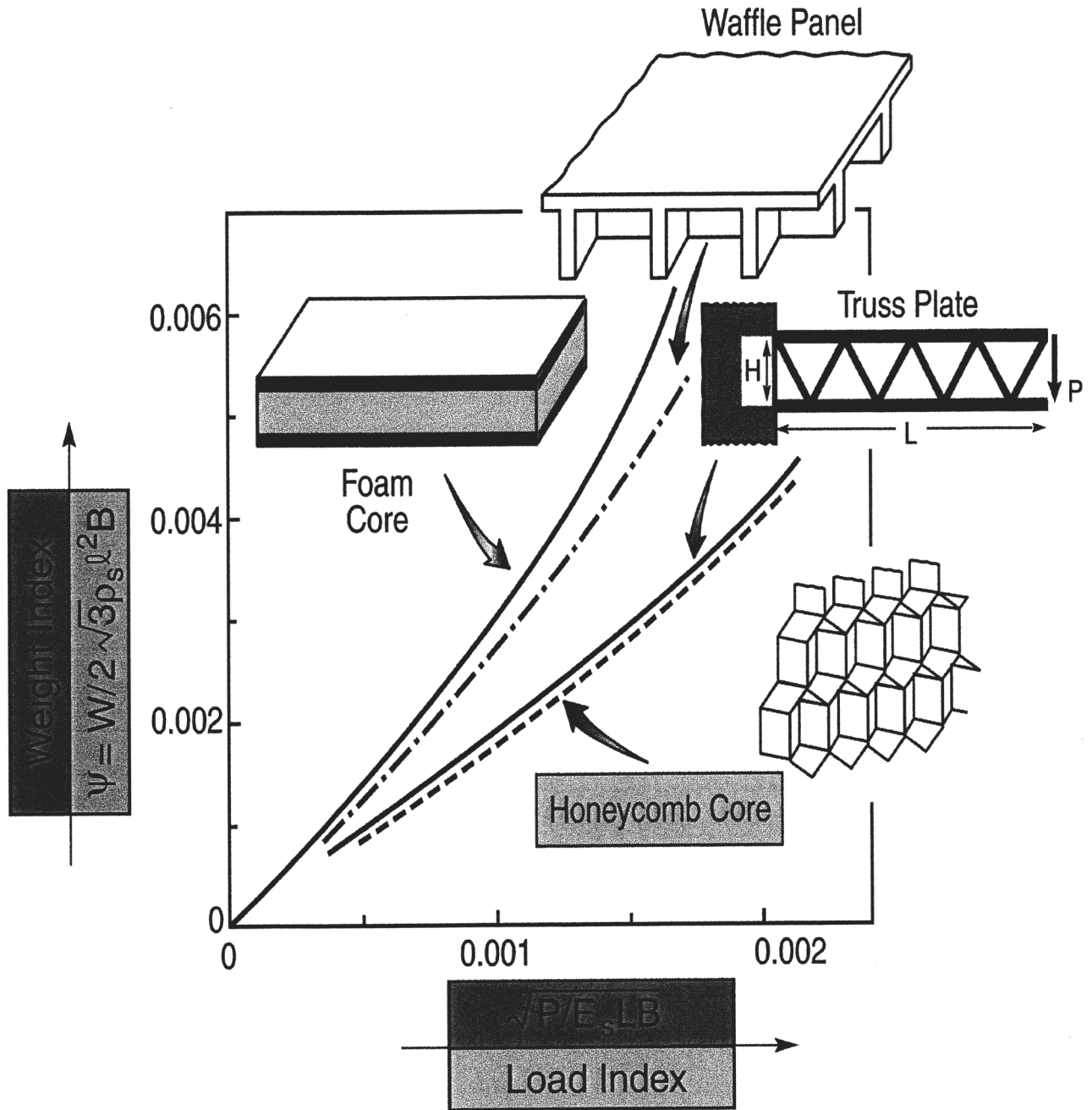

# ROBUSTNESS

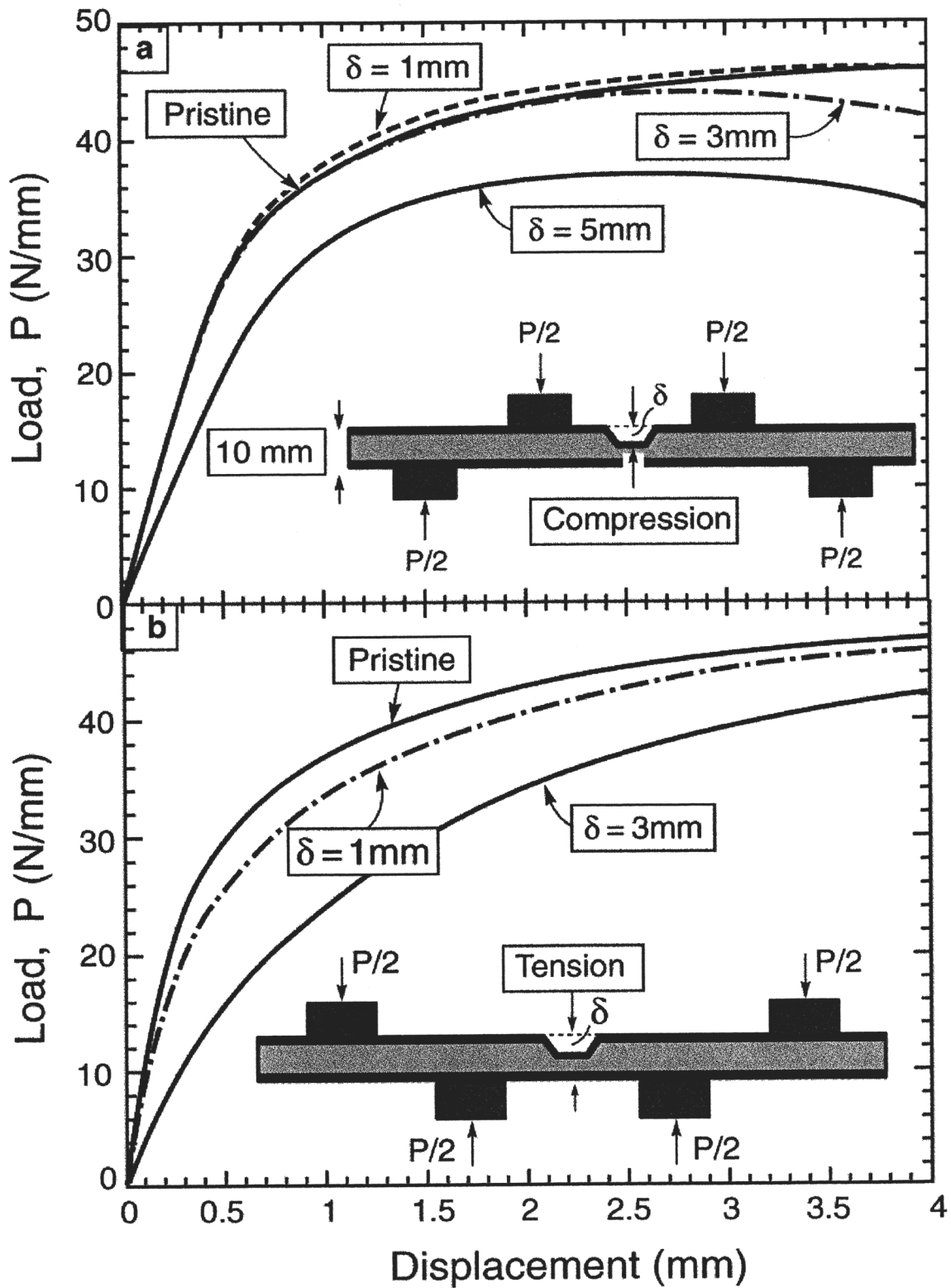

# FLAT PANELS

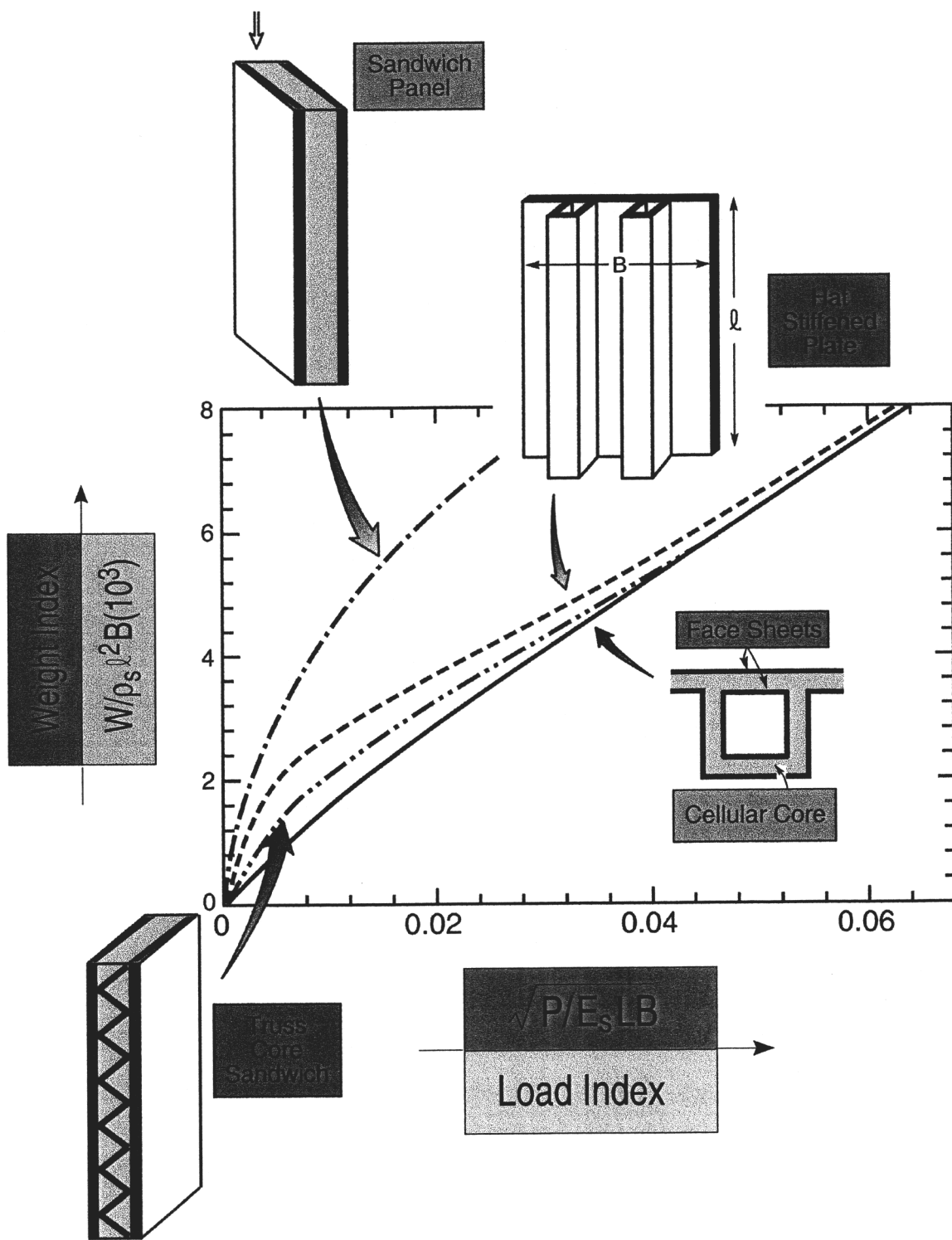

# CURVED PANELS

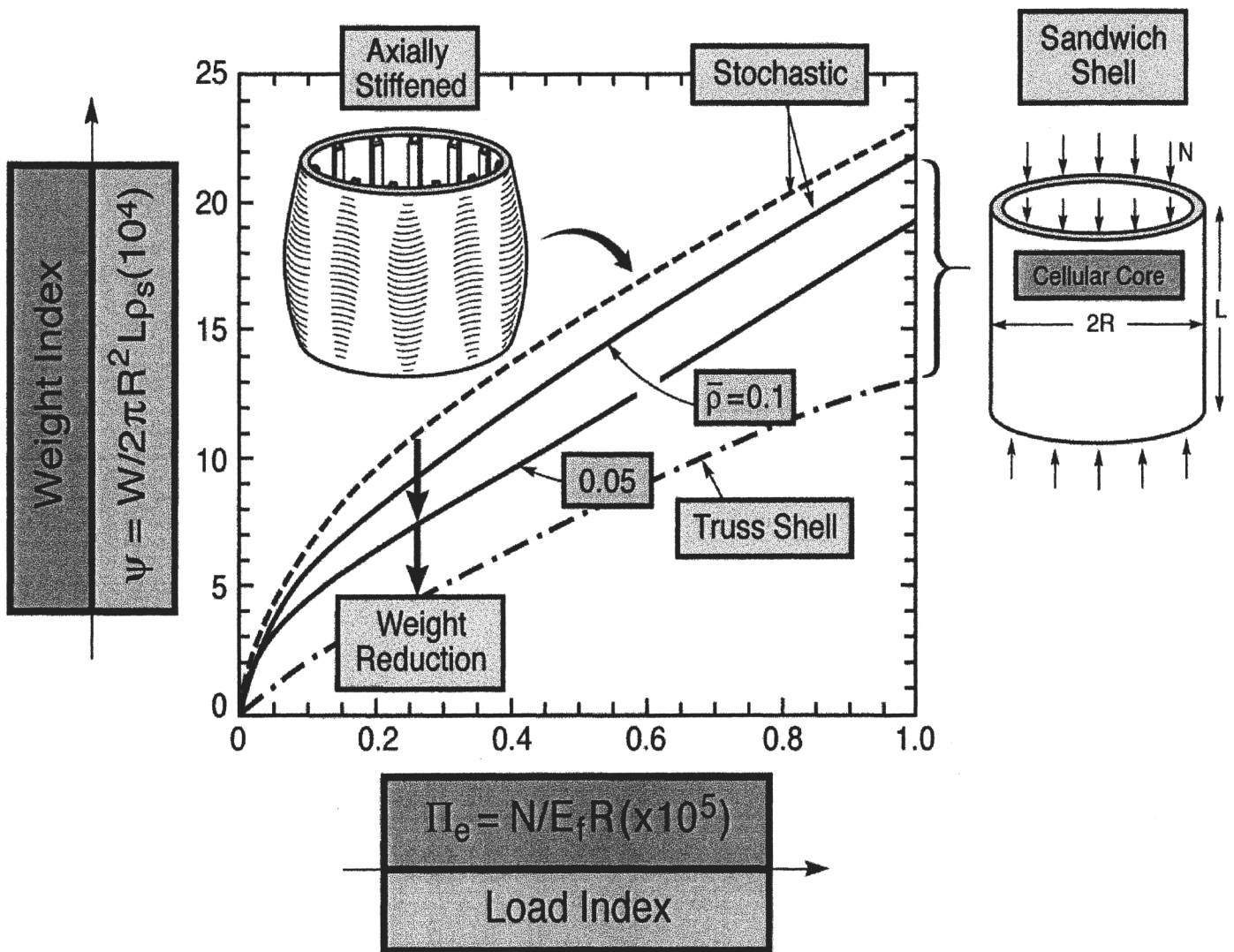

# COST/PERFORMANCE TRADE-OFF

- Inferior Performance of Stochastic Relative to Periodic
- Lower Cost of Stochastic Relative to Periodic

**Resolve Paradox Using Novel  
Fabrication Technologies**

# Wrought Stainless Steel Tetrahedral Truss

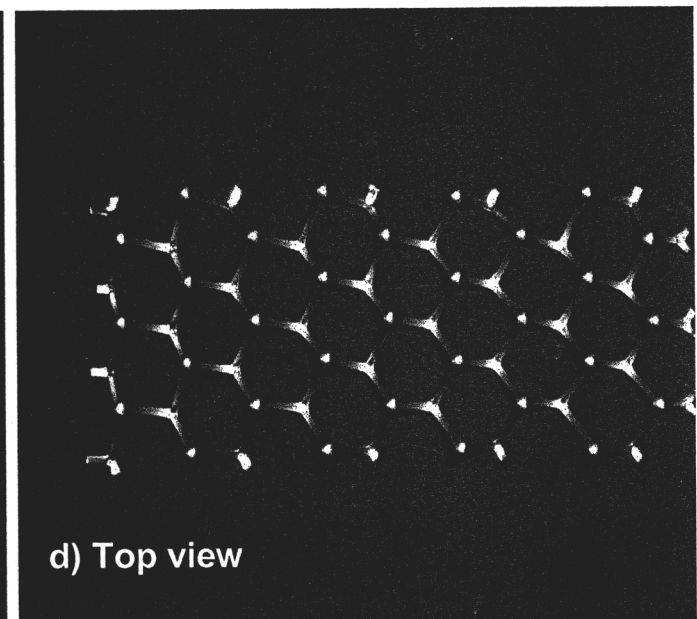
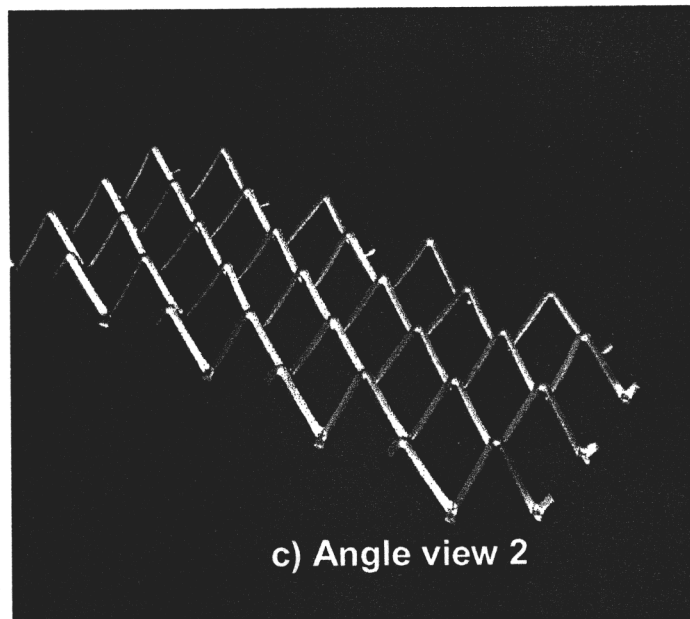
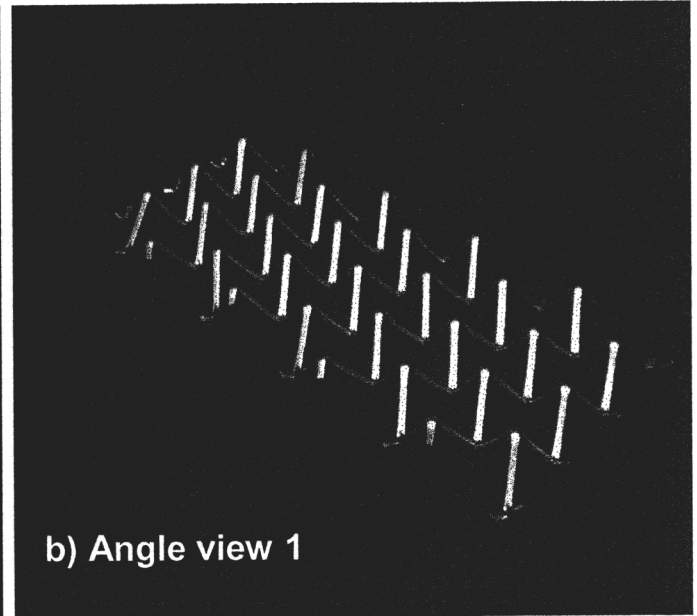
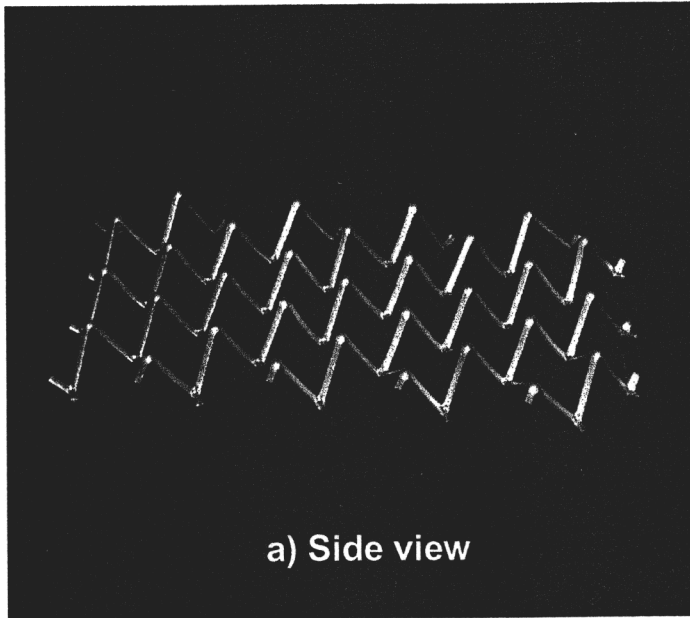

Material: 304 stainless steel  
Tetrahedron height: ~9 mm  
Relative density: ~1.6%

Truss width: ~1.25 mm  
Truss thickness: ~0.57 mm

Al alloys (6061, 5951, 3003, 1100) Ti alloys, Cu, Ni alloys

Load = 0 N;  $\delta = 0$  mm

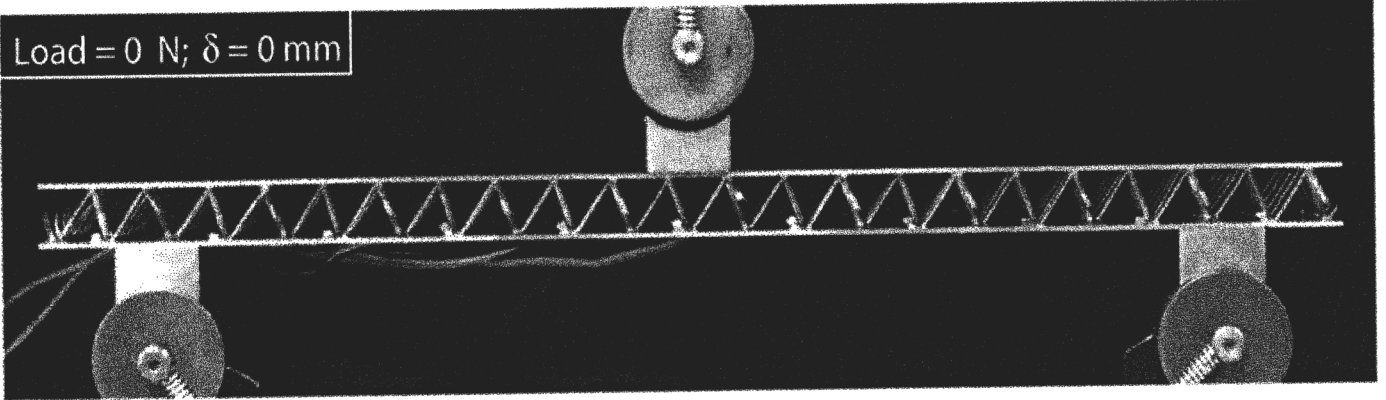

Load = 1454 N;  $\delta = 1.7$  mm

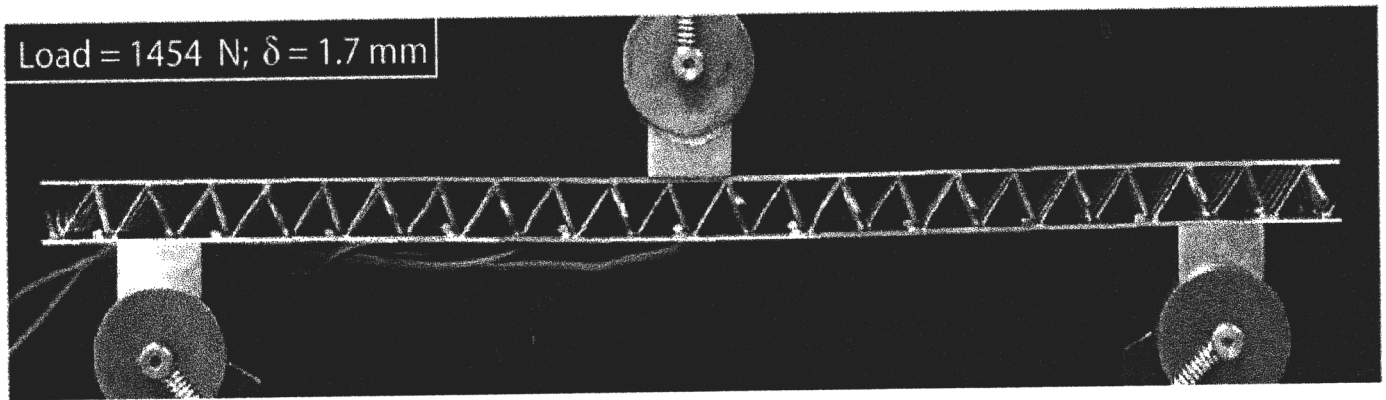

Load = 1425 N;  $\delta = 5.2$  mm

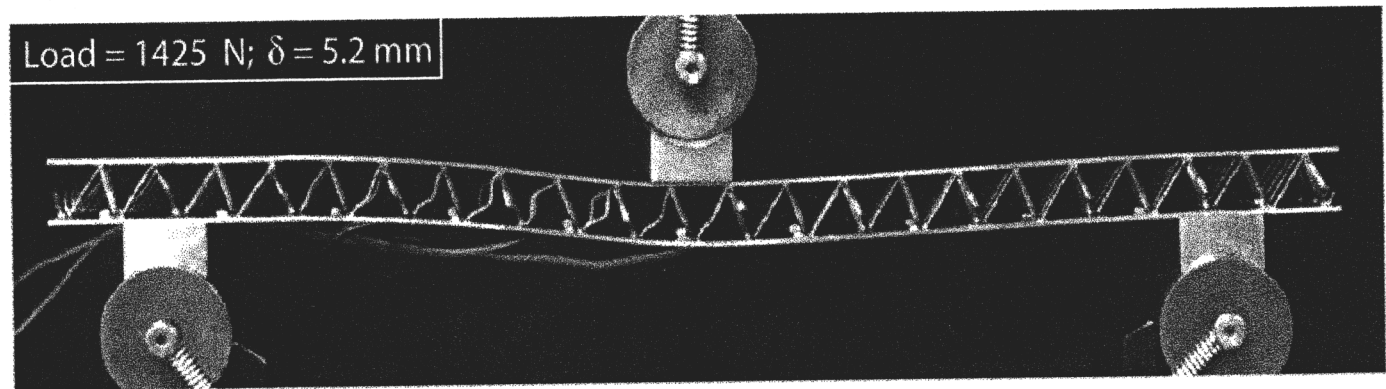

# Constructed Cellular Solid Load Response: 3-Point Bending

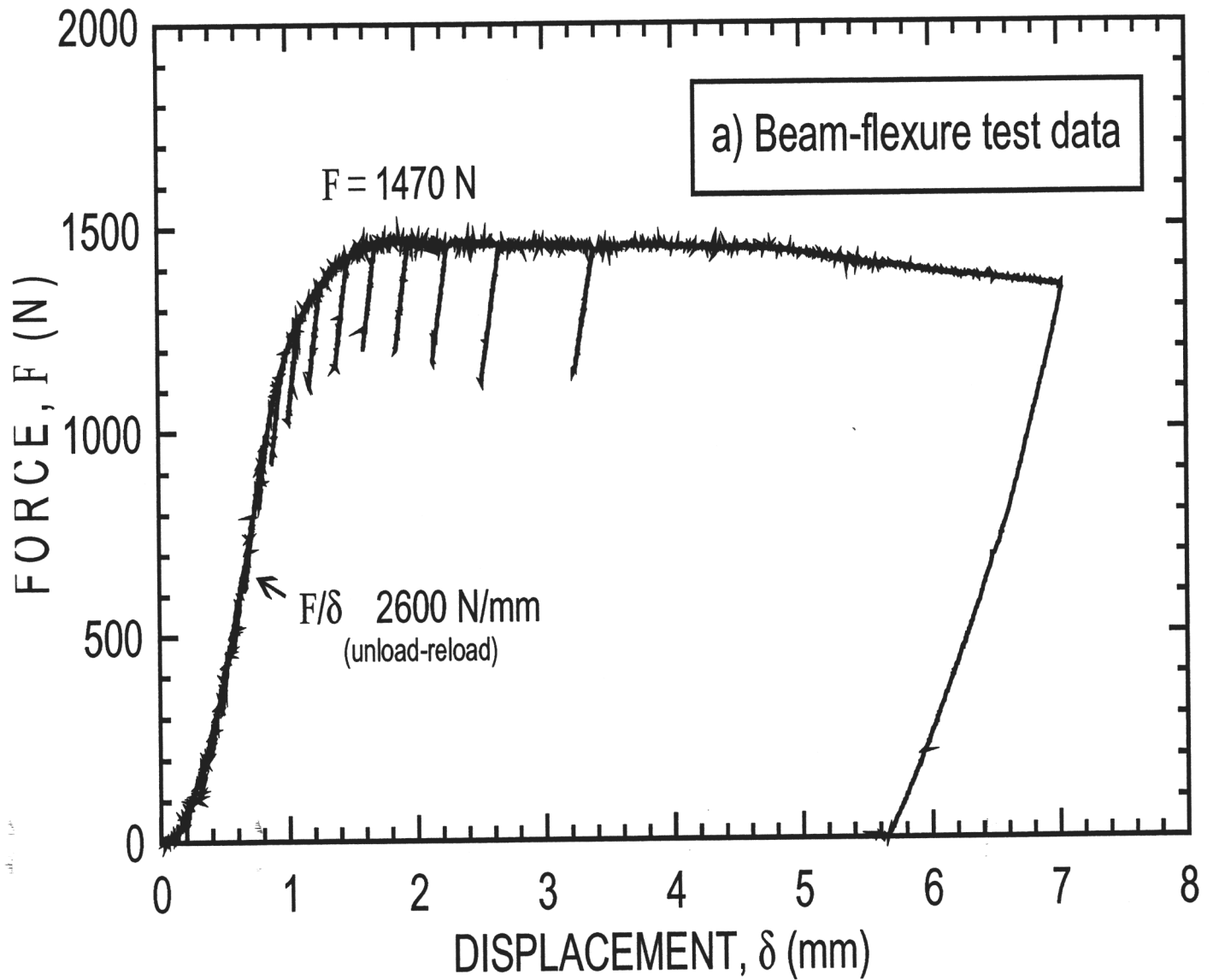

# WEAVING TECHNOLOGIES

a) Weaving

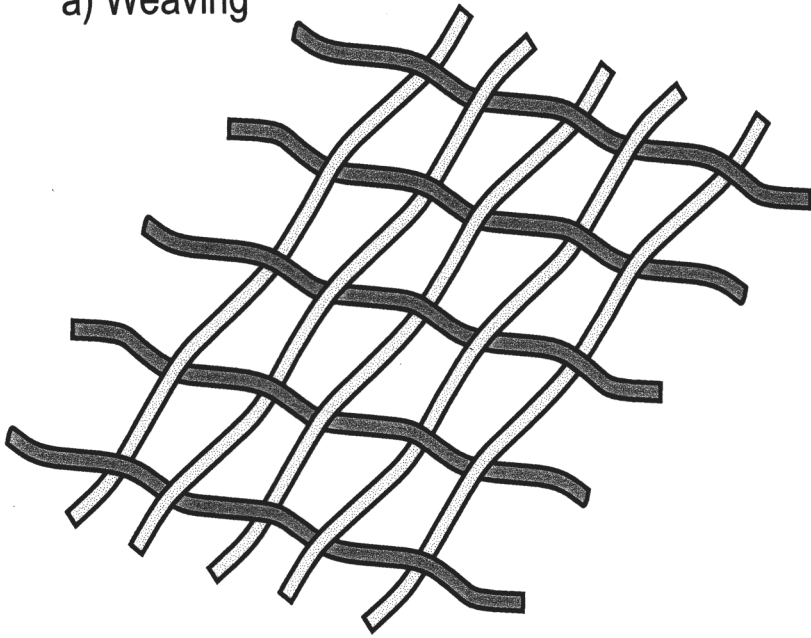

b) Knitting

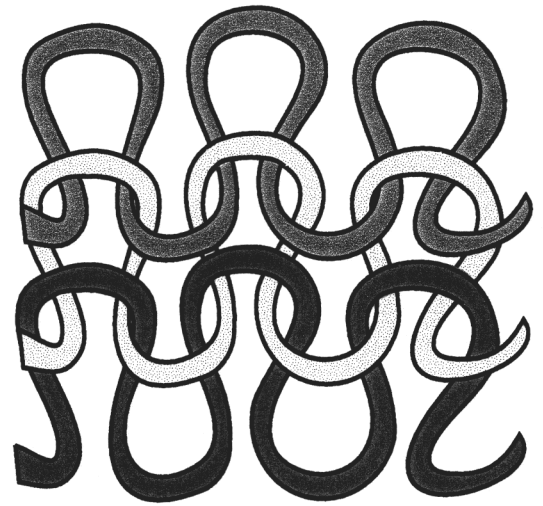

c) Braiding

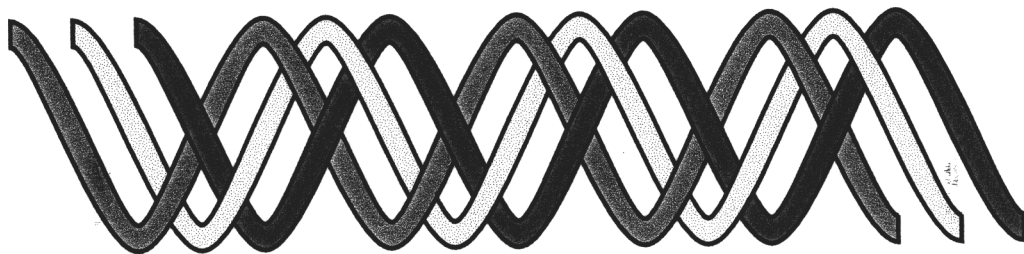

**PLAIN SQUARE WOVEN METAL CLOTH**

B-191

USE TOPOLOGY AS NEW  
VARIABLE

Plus Microstructure

USE OPEN SPACE TO ACCOMMODATE  
NEW FUNCTIONALITIES

Heat Transfer

# CELLULAR HEAT TRANSFER MEDIUM

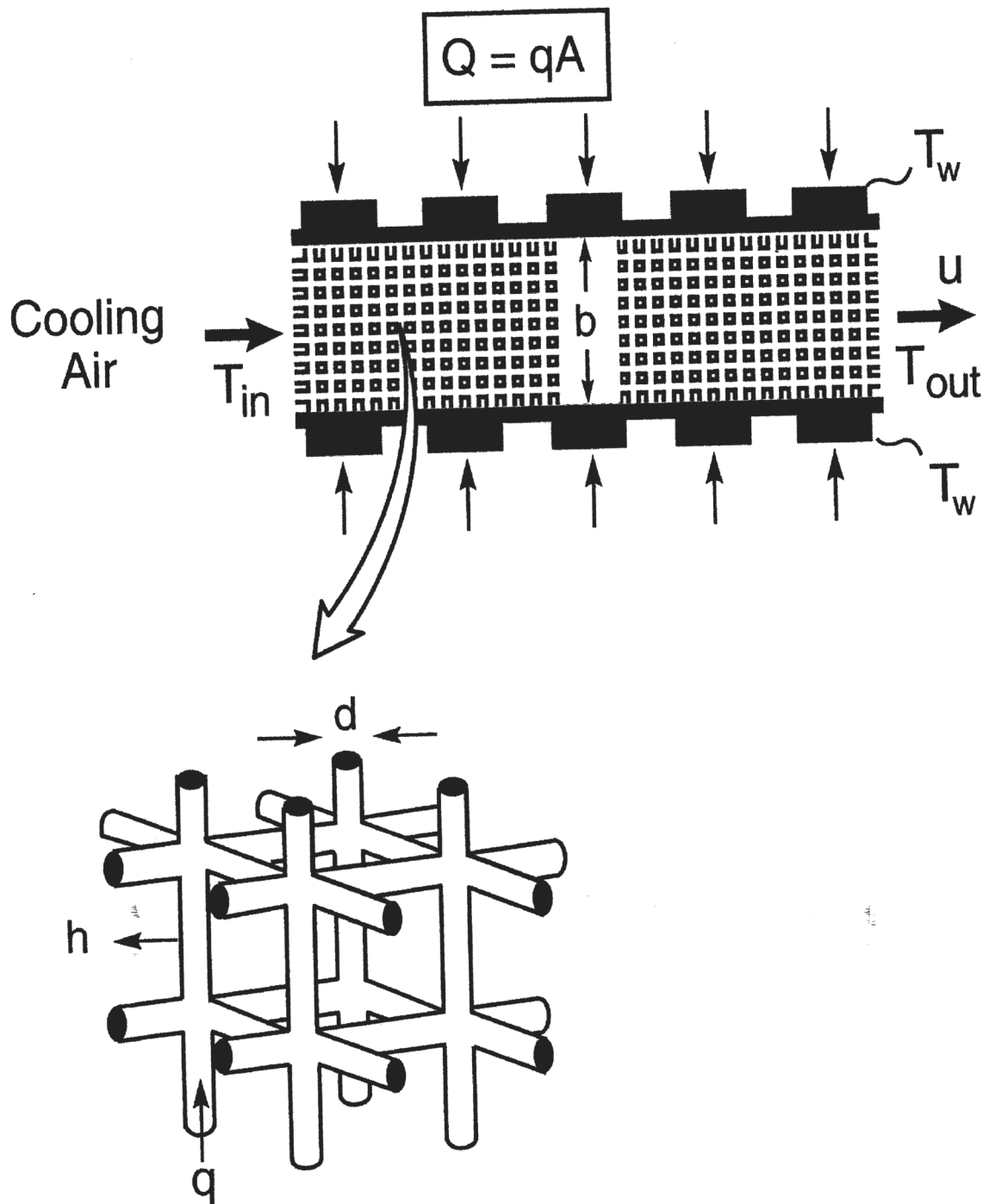

# CELLULAR HEAT TRANSFER MEDIUM

## HEAT DISSIPATION : PRESSURE DROP

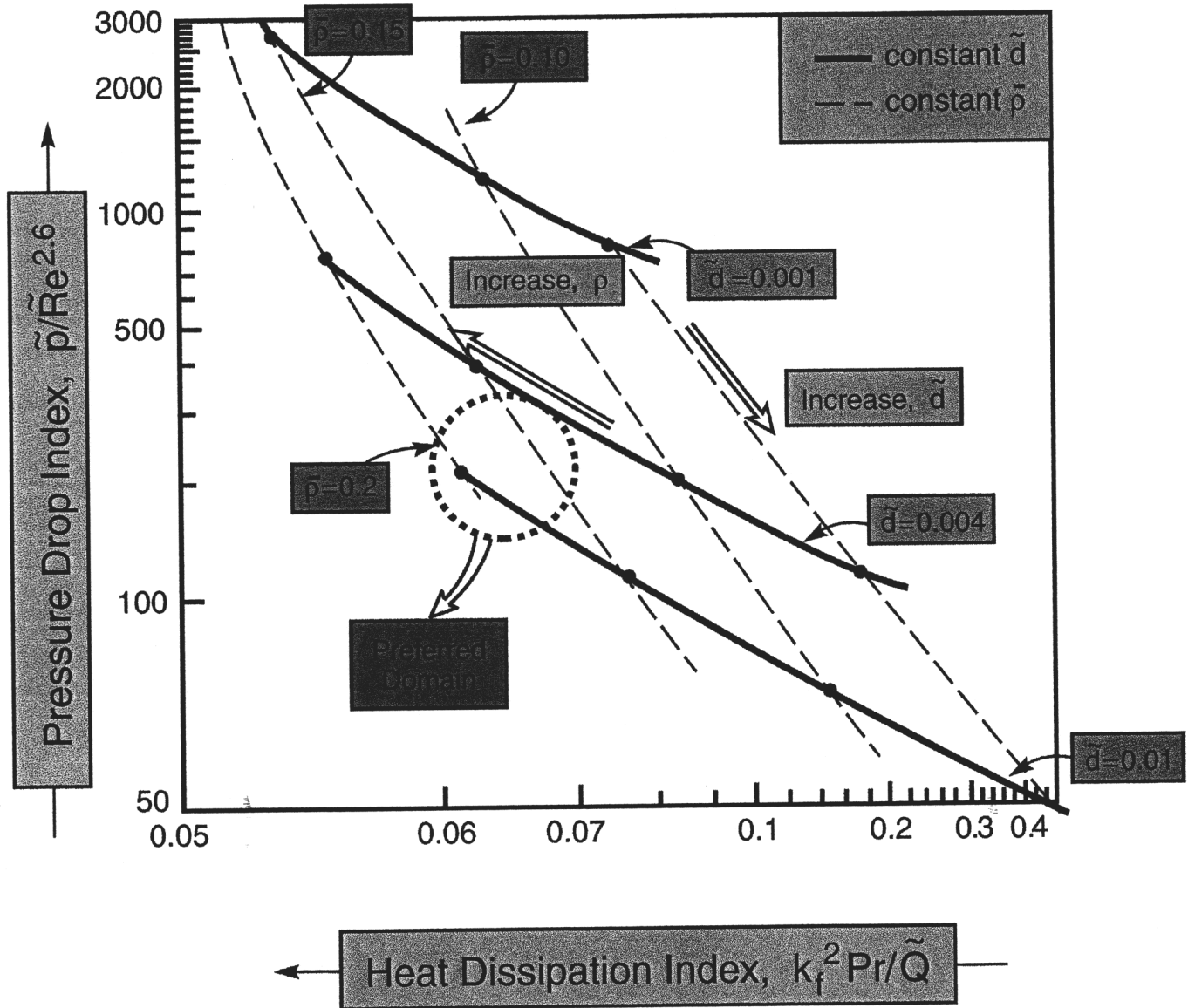

## **APPENDIX C**

### **LIST OF ATTENDEES**



**APPENDIX C**  
**LIST OF ATTENDEES**

Brian Sanders  
AFRL/VASD  
Building 45  
2130 8th St., Ste 1  
WPAFB, OH 45433-7542  
937-255-8430  
brian.sanders@wpafb.af.mil

David M. Pratt, Ph.D.  
Acting Technical Advisory  
Building 45, Room 127  
2130 8th Street, Suite 1  
Wright-Patterson AFB, OH 45433-7542  
937-255-5042  
david.pratt@wpafb.af.mil

Edward Hermes  
AFRL/MLSC  
Building 652  
2179 12th St.  
WPAFB, OH 45433-7718  
937-904-5046

Keith Numbers  
AFRL/VA  
Building 45  
2130 8th St., STE 1  
WPAFB, OH 45433-7542  
937-656-4169  
keith.numbers@wpafb.af.mil

Steven Fishman  
Office of Naval Research  
Code 332  
800 N. Quincy St.  
Arlington, VA 22217-5660  
703-696-0850  
fishmas@onr.navy.mil

Mark Gustafson  
ASC/ENFP

2530 Loop Road West  
Wright-Patterson AFB, OH 45433-7101  
937-255-7114  
mark.Gustafson@wpafb.af.mil

Peter Coen  
NASA Langley Research Center  
MS 348  
Hampton, VA 23681  
757-864-5991  
p.g.coen@larc.nasa.gov

Dennis L. Discus, Associate Head  
Metals and Thermal Structures Branch  
NASA Langley Research Center  
Mail Stop 188A  
Hampton, VA 23681-0001  
757-864-3137  
d.l.discus@larc.nasa.gov

Michael P. Nemeth, Associate Head  
Mechanics and Durability Branch  
NASA Langley Research Center  
Mail Stop 188E  
Hampton, VA 23681-0001  
757-864-3184  
m.p.nemeth@larc.nasa.gov

Leo Christodoulou  
DARPA/DSO  
3701 N. Fairfax Drive  
Arlington, VA 22203  
703-696-2374  
lchristodoulou@darpa.mil

Rich Wlezien  
DARPA/TTO  
3701 N. Fairfax Drive  
Arlington, VA 22203  
703-696-2377  
rwlezien@darpa.mil

Jonathan Bartley-Cho  
Northrop Grumman Corporation  
Air Combat Systems  
Structural Development  
M/S 9L11/W5  
One Hornet Way

El Segundo, CA 90245  
310-331-5004  
bartljo@mail.northgrum.com

Jay Kudva  
Northrop Grumman Corporation  
Manager, Structures Technology Development  
M/S 9L11/W5  
One Hornet Way  
El Segundo, CA 90245  
310-332-8300

Billy Burroughs  
QSP Program Manager  
Boeing Phantom Works  
2401 E. Wardlow Road  
Long Beach, CA 90807-5310  
562-593-9265  
billy.burroughs@west.boeing.com

Tim McGann  
Senior Manager, Advanced Materials and Process Technology  
Boeing Phantom Works  
2401 E. Wardlow Road  
Long Beach, CA 90807-5310  
562-593-9265  
timothy.mcgann@west.boeing.com

Bryan Kreimendahl  
Lockheed Martin  
Advanced Development Projects  
1011 Lockheed Way  
Palmdale, CA 93599  
661-572-5376  
brian.kreimendahl@lmco.com

Grant Carichner  
Lockheed Martin  
Advanced Development Projects  
1011 Lockheed Way  
Palmdale, CA 93599  
661-572-5376  
grant.carichner@lmco.com

Frank Simmons  
Gulfstream Aerospace Corporation  
P.O. Box 2206, M/S G07  
Savannah, GA 31402-2206

912-965-3629  
frank.simmons.iii@gulfaero.com

Anthony Evans  
Princeton University  
Princeton Materials Institute  
5 New South Building  
Princeton, NJ 08544  
609-258-4762  
anevans@princeton.edu

Haydn Wadley  
University of Virginia  
School of Engineering  
P.O. Box 400240  
Charlottesville, VA 22904  
804-924-0828  
haydn@virginia.edu

Lisa Veitch  
Institute for Defense Analyses  
1801 N. Beauregard Street  
Alexandria, VA 22311  
703-578-2864  
lveitch@ida.org

Bill Hong  
Institute for Defense Analyses  
1801 N. Beauregard Street  
Alexandria, VA 22311  
703-578-2826  
whong@ida.org

Art Diness  
Institute for Defense Analyses  
1801 N. Beauregard Street  
Alexandria, VA 22311  
703-578-6884  
adiness@ida.org

Andrea Hartman  
Institute for Defense Analyses  
1801 N. Beauregard Street  
Alexandria, VA 22311  
703-845-2152  
ahartman@ida.org

**REPORT DOCUMENTATION PAGE**Form Approved  
OMB No. 0704-0188

Public reporting burden for this collection of information is estimated to average 1 hour per response, including the time for reviewing instructions, searching existing data sources, gathering and maintaining the data needed, and completing and reviewing this collection of information. Send comments regarding this burden estimate or any other aspect of this collection of information, including suggestions for reducing this burden to Department of Defense, Washington Headquarters Services, Directorate for Information Operations and Reports (0704-0188), 1215 Jefferson Davis Highway, Suite 1204, Arlington, VA 22202-4302. Respondents should be aware that notwithstanding any other provision of law, no person shall be subject to any penalty for failing to comply with a collection of information if it does not display a currently valid OMB control number. **PLEASE DO NOT RETURN YOUR FORM TO THE ABOVE ADDRESS.**

1. REPORT DATE Julv 2001		2. REPORT TYPE Final		3. DATES COVERED (From-To) June 2001 – Julv 2001	
4. TITLE AND SUBTITLE Quiet Supersonic Platform (QSP) Materials and Structures Focus Group Meeting, 26 June 2001				5a. CONTRACT NUMBER DAS W01 98 C 0067	
				5b. GRANT NUMBER	
				5c. PROGRAM ELEMENT NUMBER	
6. AUTHOR(S) Andrea Hartman, William Hong, Lisa Veitch (Editors)				5d. PROJECT NUMBER	
				5e. TASK NUMBER DA-2-1822	
				5f. WORK UNIT NUMBER	
7. PERFORMING ORGANIZATION NAME(S) AND ADDRESS(ES) Institute for Defense Analyses 4850 Mark Center Drive Alexandria, VA 22311-1882				8. PERFORMING ORGANIZATION REPORT NUMBER IDA Document D-2627	
9. SPONSORING / MONITORING AGENCY NAME(S) AND ADDRESS(ES) DARPA/TTO 3701 N. Fairfax Drive Arlington, VA 22203-1714				10. SPONSOR/MONITOR'S ACRONYM(S)	
				11. SPONSOR/MONITOR'S REPORT NUMBER(S)	
12. DISTRIBUTION / AVAILABILITY STATEMENT Approved for public release; distribution unlimited.					
13. SUPPLEMENTARY NOTES					
14. ABSTRACT This document is a proceedings of presentations and discussions conducted at Focus Group meeting on Materials and Structures for the DARPA Quiet Supersonic Platform (QSP) program, which took place at the Institute for Defense Analyses in June 2001. Attendees from aircraft companies, universities, and Government laboratories discussed possible new materials and structures fabrication approaches applicable to lightweight aircraft capable of supersonic flight, as defined by the Goals of the QSP program.					
15. SUBJECT TERMS aircraft structural materials, cellular materials, Quiet Supersonic Platform, structural materials design, supersonic aircraft structures, synthetic multifunctional materials, truss structures					
16. SECURITY CLASSIFICATION OF:			17. LIMITATION OF ABSTRACT  SAR	18. NUMBER OF PAGES  228	19a. NAME OF RESPONSIBLE PERSON Mr. Steve Walker
a. REPORT Uncl.	b. ABSTRACT Uncl.	c. THIS PAGE Uncl.			19b. TELEPHONE NUMBER (include area code) 703-696-2377