

# REPORT DOCUMENTATION PAGE

*Form Approved*  
**OMB No. 0704-0188**

Public reporting burden for this collection of information is estimated to average 1 hour per response, including the time for reviewing instructions, searching existing data sources, gathering and maintaining the data needed, and completing and reviewing this collection of information. Send comments regarding this burden estimate or any other aspect of this collection of information, including suggestions for reducing this burden to Department of Defense, Washington Headquarters Services, Directorate for Information Operations and Reports (0704-0188), 1215 Jefferson Davis Highway, Suite 1204, Arlington, VA 22202-4302. Respondents should be aware that notwithstanding any other provision of law, no person shall be subject to any penalty for failing to comply with a collection of information if it does not display a currently valid OMB control number. PLEASE DO NOT RETURN YOUR FORM TO THE ABOVE ADDRESS.

<b>1. REPORT DATE (DD-MM-YYYY)</b>		<b>2. REPORT TYPE</b> Technical Papers		<b>3. DATES COVERED (From - To)</b>	
<b>4. TITLE AND SUBTITLE</b>				<b>5a. CONTRACT NUMBER</b>	
				<b>5b. GRANT NUMBER</b>	
				<b>5c. PROGRAM ELEMENT NUMBER</b>	
<b>6. AUTHOR(S)</b>				<b>5d. PROJECT NUMBER</b> 2303	
				<b>5e. TASK NUMBER</b> m2c8	
				<b>5f. WORK UNIT NUMBER</b>	
<b>7. PERFORMING ORGANIZATION NAME(S) AND ADDRESS(ES)</b> Air Force Research Laboratory (AFMC) AFRL/PRS 5 Pollux Drive Edwards AFB CA 93524-7048				<b>8. PERFORMING ORGANIZATION REPORT</b>	
<b>9. SPONSORING / MONITORING AGENCY NAME(S) AND ADDRESS(ES)</b> Air Force Research Laboratory (AFMC) AFRL/PRS 5 Pollux Drive Edwards AFB CA 93524-7048				<b>10. SPONSOR/MONITOR'S ACRONYM(S)</b>	
				<b>11. SPONSOR/MONITOR'S NUMBER(S)</b>	
<b>12. DISTRIBUTION / AVAILABILITY STATEMENT</b>  Approved for public release; distribution unlimited.					
<b>13. SUPPLEMENTARY NOTES</b>					
<b>14. ABSTRACT</b>					
<b>15. SUBJECT TERMS</b>  1121 028					
<b>16. SECURITY CLASSIFICATION OF:</b>			<b>17. LIMITATION OF ABSTRACT</b>	<b>18. NUMBER OF PAGES</b>	<b>19a. NAME OF RESPONSIBLE PERSON</b>
<b>a. REPORT</b>	<b>b. ABSTRACT</b>	<b>c. THIS PAGE</b>			Leilani Richardson
Unclassified	Unclassified	Unclassified	A		<b>19b. TELEPHONE NUMBER</b> <small>(include area code)</small> (661) 275-5015

62

separate items are enclosed

CF

TP-FY99-0130

✓ Squadsheet  
✓ DTS

MEMORANDUM FOR PRR (Contractor/In-House Publication)

FROM: PROI (TI) (STINFO)

2 June 1999

SUBJECT: Authorization for Release of Technical Information, Control Number: AFRL-PR-ED-TP-FY99-0130  
J. Harper and C.W. Larson, "Promising Thermal Source of Boron Atoms"  
Poster Session HEDM

(Public Release)

---

## Promising Thermal Source of Boron Atoms

J. Harper and C. W. Larson  
Propulsion Science and Advanced Concepts Division  
Air Force Research Laboratory  
10 E. Saturn Blvd.  
Edwards AFB, CA 93524-7680

A "cannon" design has been tested as a high flux thermal source of pure boron atoms. Boron is packed into a central channel of a 1/4 in. graphite rod with the open end pointed towards the deposition substrate. A refractory metal sheath surrounds and heats the carbon as the applied current increases. Successful argon matrix isolation experiments indicate that the boron cannon will be an effective way to produce pure boron atoms. Products from previous thermal techniques that used carbon as a container in which to heat boron, have been heavily contaminated with carbon and boron/carbon compounds. The cannon design exploits the difference in vapor pressures of boron and carbon at a given temperature. The design, operating temperature, and procedure for heating the cannon are still being optimized. Because of the higher flux of boron, hard to detect species such as  $B_2C$ , are more easily observed. Experiments also confirm that carbon monoxide (CO) is a thorough scavenger of boron atoms. When large amounts of CO are present, BCO and clusters of these molecules are the only products. This procedure could be developed into a diagnostic for the presence of B atoms.

DISTRIBUTION STATEMENT A:  
Approved for Public Release -  
Distribution Unlimited

20021121 028

Goal: Development of High Flux Pure Boron Atom Source

Approach: Resistive heating of boron sample  
(Preferred to ion beam or laser ablation)

Problem: Hot boron alloys with most materials. In previous designs resistive heating circuit is broken when components attacked by boron.

Possible Solution: Thick sacrificial carbon holder for boron. Heat gradually to prevent carbon atoms/clusters from mixing with the boron.

Contributes to HEDM group's objective of demonstrating 5% boron atoms in solid hydrogen.

# “Boron Cannon” Thermal Source

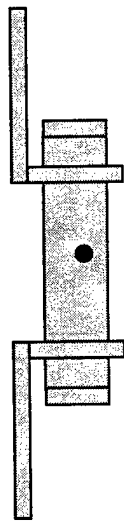

Previous design very vulnerable to alloying of boron with metal near hole

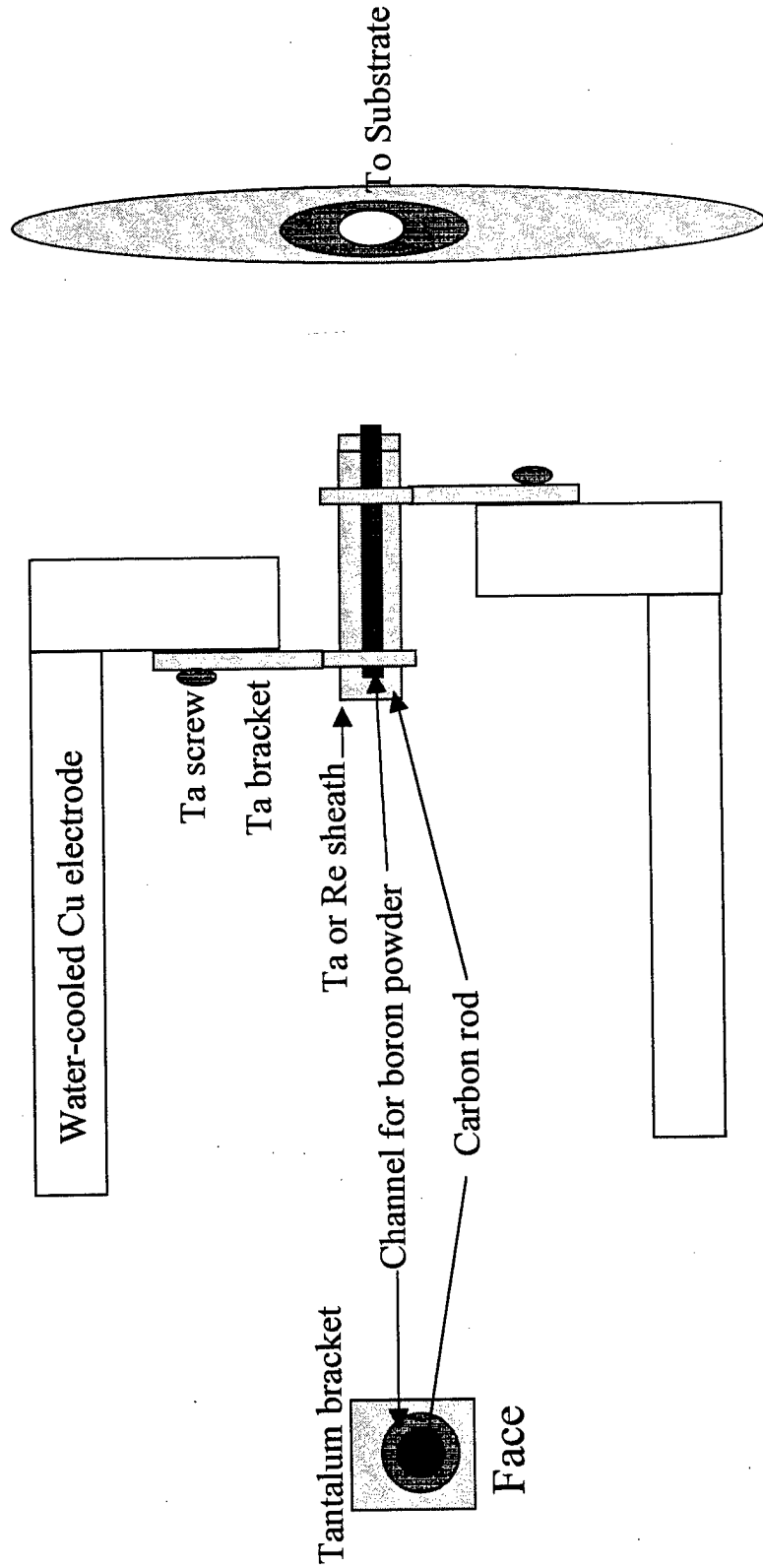

Open Side View

Water-cooled copper heatshield

## Experimental Observations:

Removed refractory metal and heated carbon rod directly. Difficulty in maintaining good electrical contact between carbon and copper electrodes. Reinstalled refractory metal.

Must isolate refractory metal from boron with thick carbon liner. An attempt was made to increase the temperature at the front of the cannon by reducing the thermal conductivity at the front bracket. When <sup>it was</sup> discovered that the middle was still the hottest point, the cannon channel was only packed half full with boron. Thus the "front" of the boron plug was located in the hottest part of the rod--the center.

Rhenium was used instead of traditional tantalum. If this can be protected from boron, the rhenium sheath can be reused. Tantalum becomes too brittle for reuse after cycling to high temperature.

In the current emergency set-up it is impossible to see the front or center of the cannon to measure the temperature. An optical pyrometer is used to measure the temperature of the brackets and back of cannon. Can estimate the temperature of the experiment by the increase in temperature of the substrate due to the heat load on it. Analysis of the amount of larger clusters condensed during deposition is also an indication of substrate temperature.

# B<sub>2</sub>C

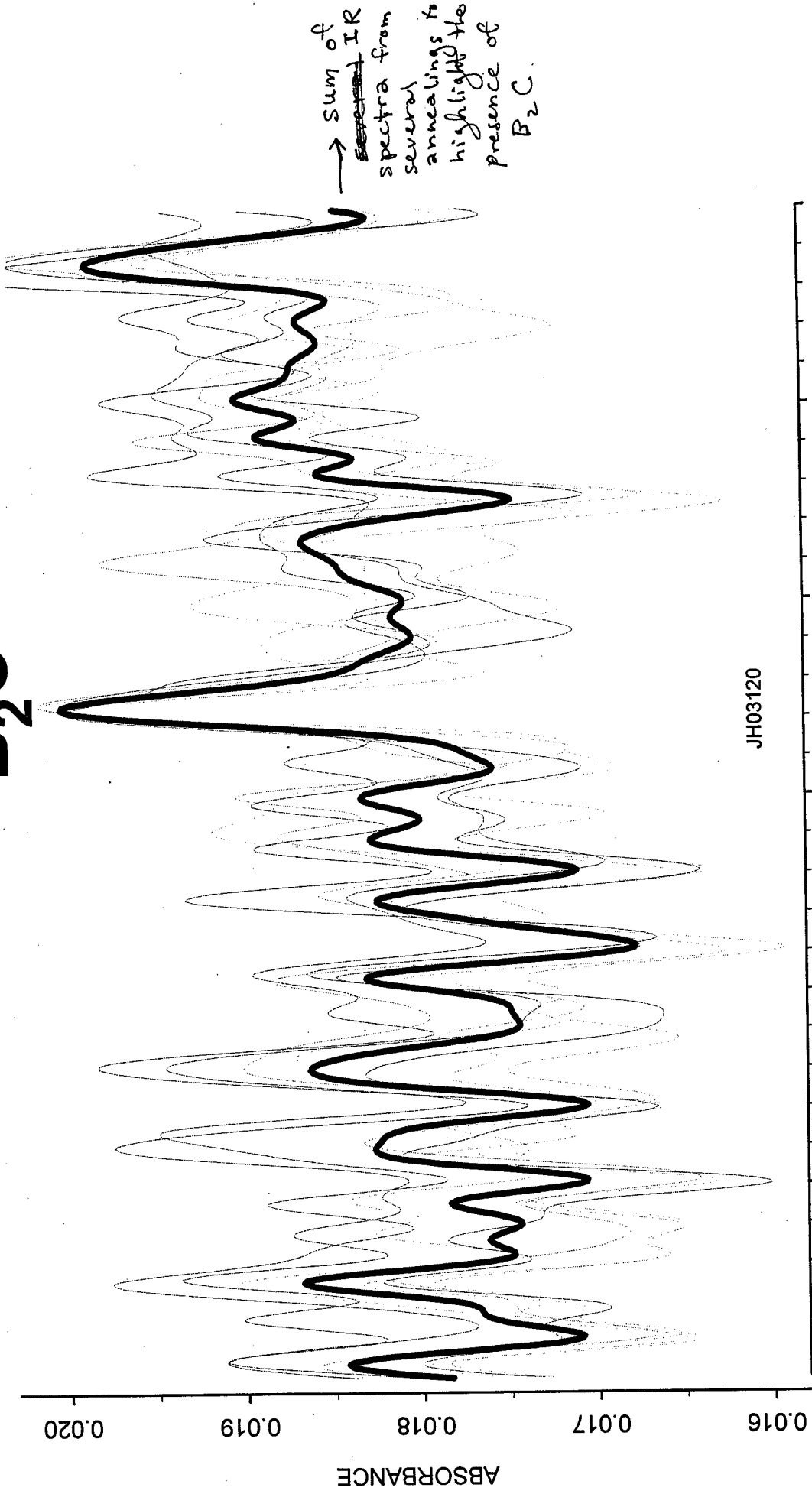

WAVENUMBERS

JHB2C3-1.axg May 21, 1999 10:40:11 AM

JH03120

JH03120

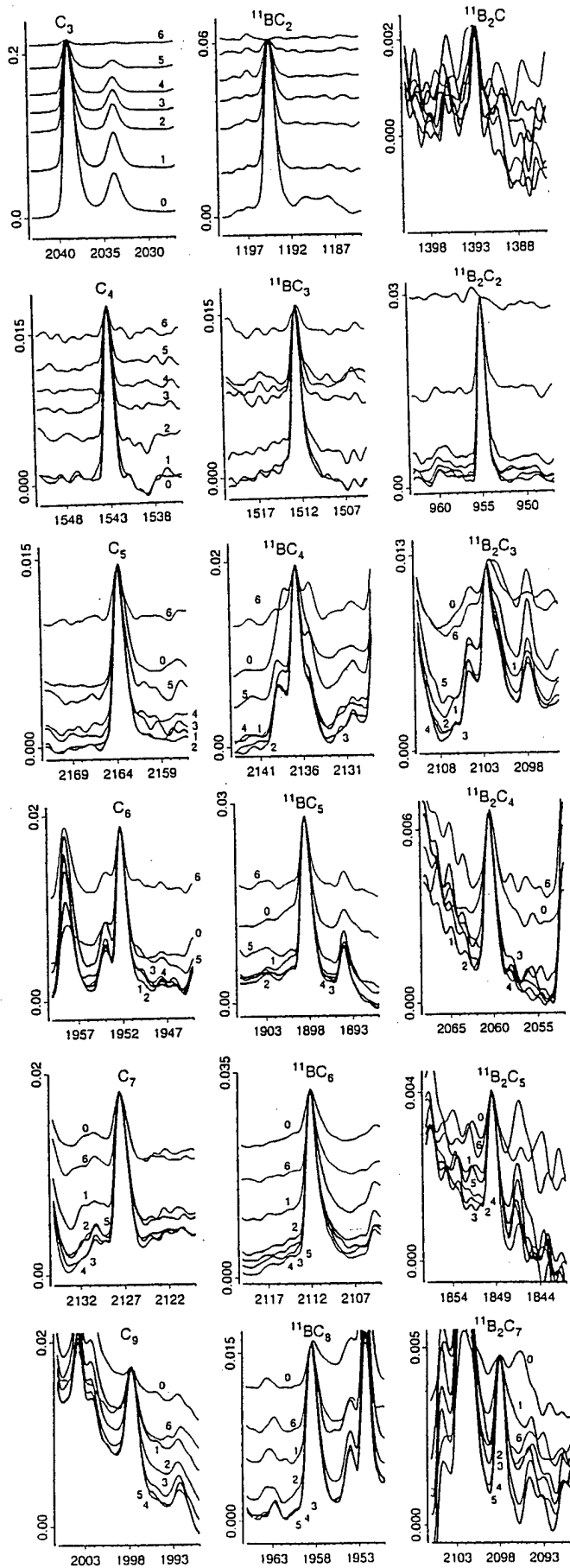

Species  
Observed

+ changes  
in their  
abundance  
according to  
annealing

Will be enlarged  
to readable size  
for poster!

# INITIAL SPECTRA

— 40 min at 2100 and 35 mins at 2300°C  
 ⊙ 20 mins at 2100°C  
 × 35 mins from 1900 to 2200, 60 min at 2300°C

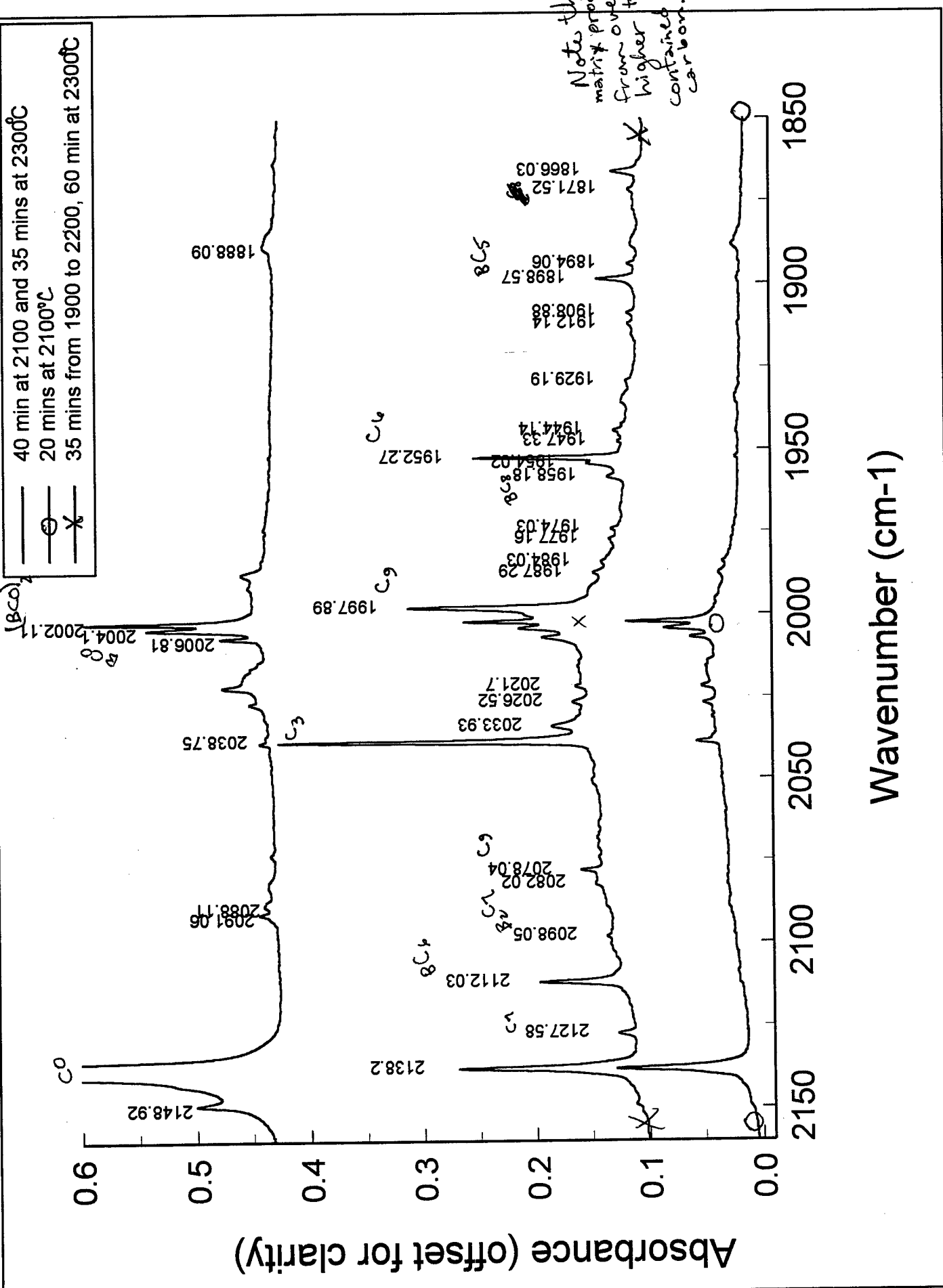

# INITIAL SPECTRA

- 40 min at 2100 and 35 mins at 2300°C
- 20 mins at 2100°C
- × 35 mins from 1900 to 2200, 60 min at 2300°C

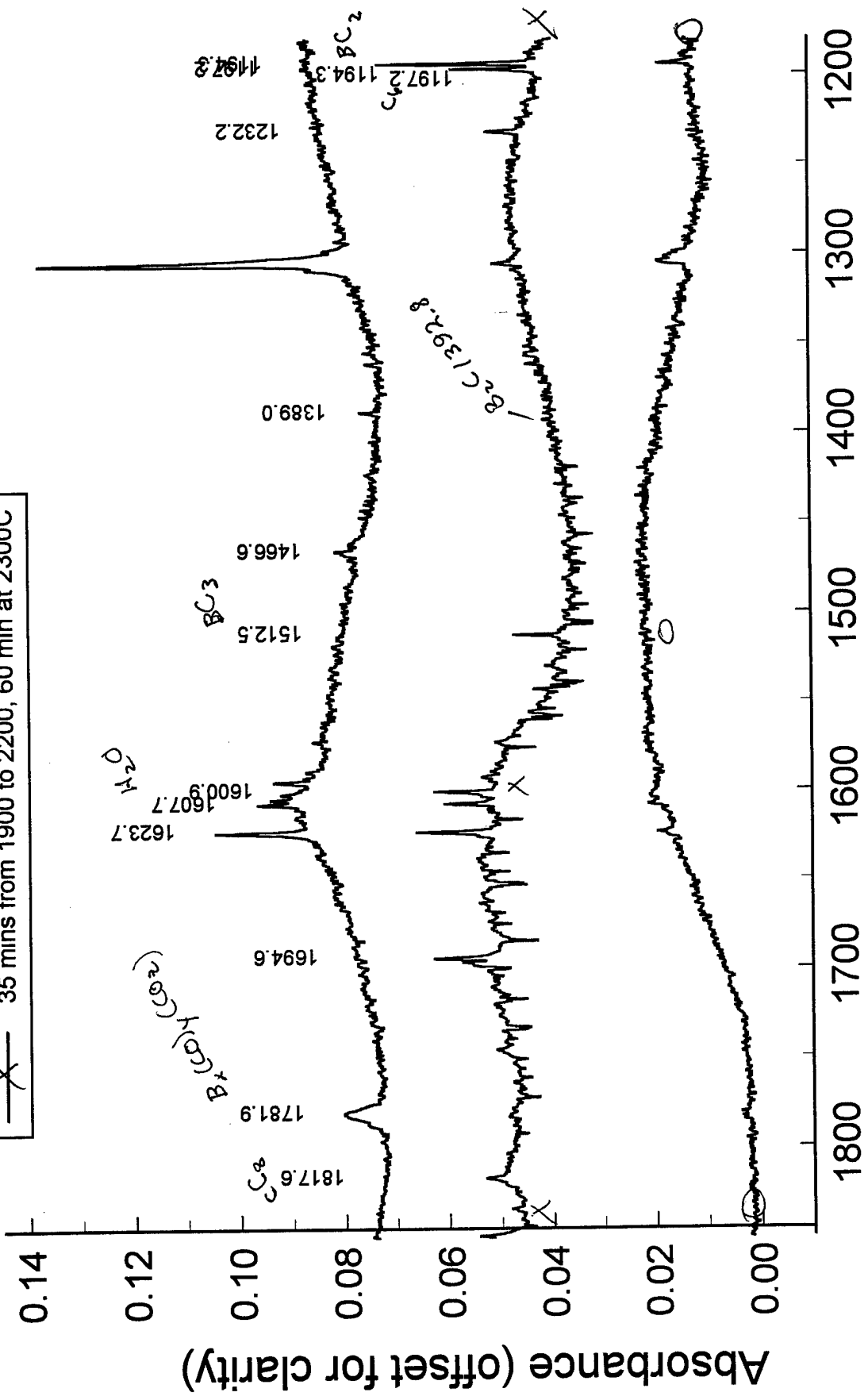

# Annealed Spectra

- 40 min at 2100 and 35 mins at 2300°C
- 20 mins at 2100°C
- X 35 mins from 1900 to 2200, 60 min at 2300°C

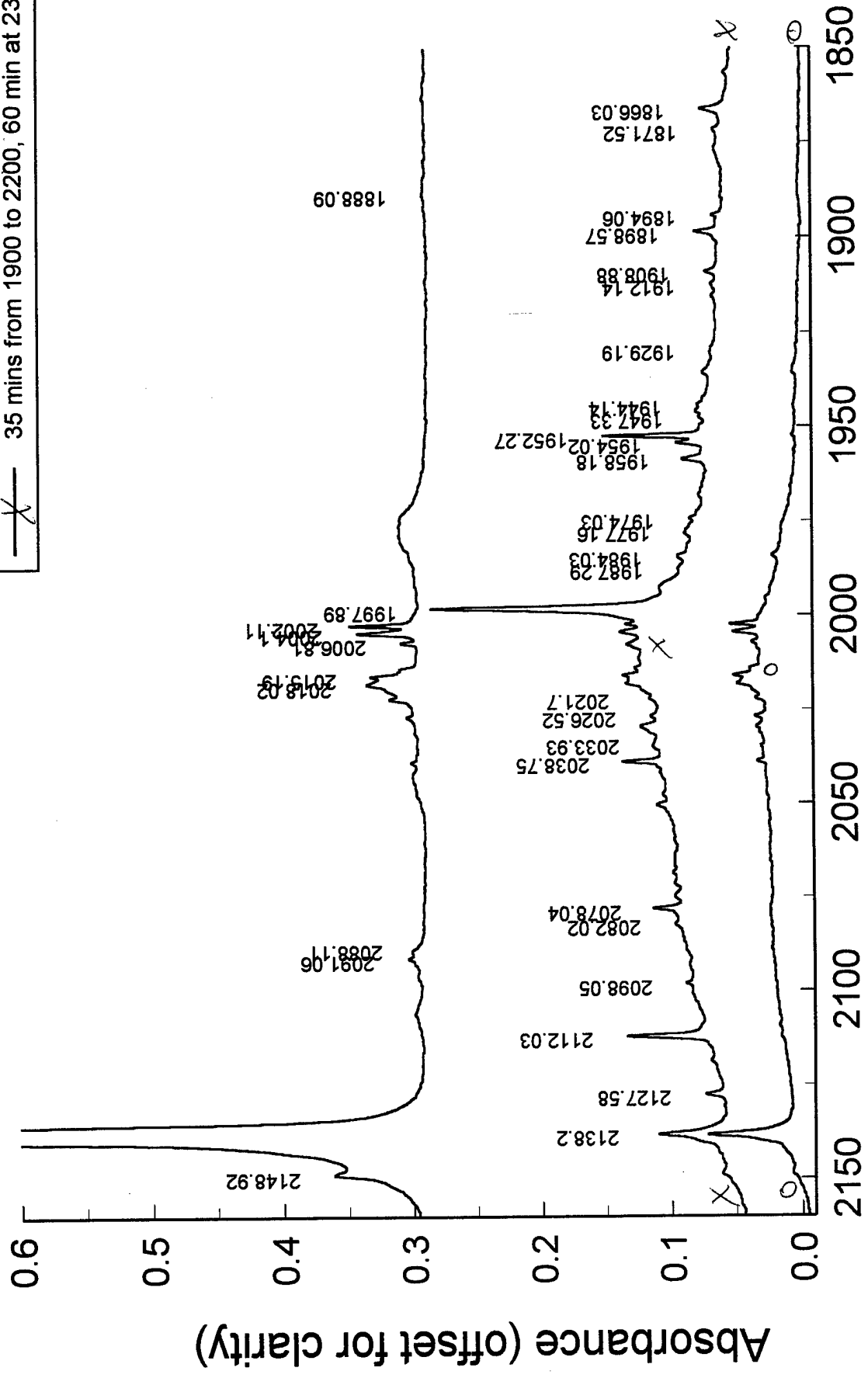

# Annealed Spectra

- 40 min at 2100 and 35 mins at 2300°C
- 20 mins at 2100°C
- × 35 mins from 1900 to 2200, 60 min at 2300°C

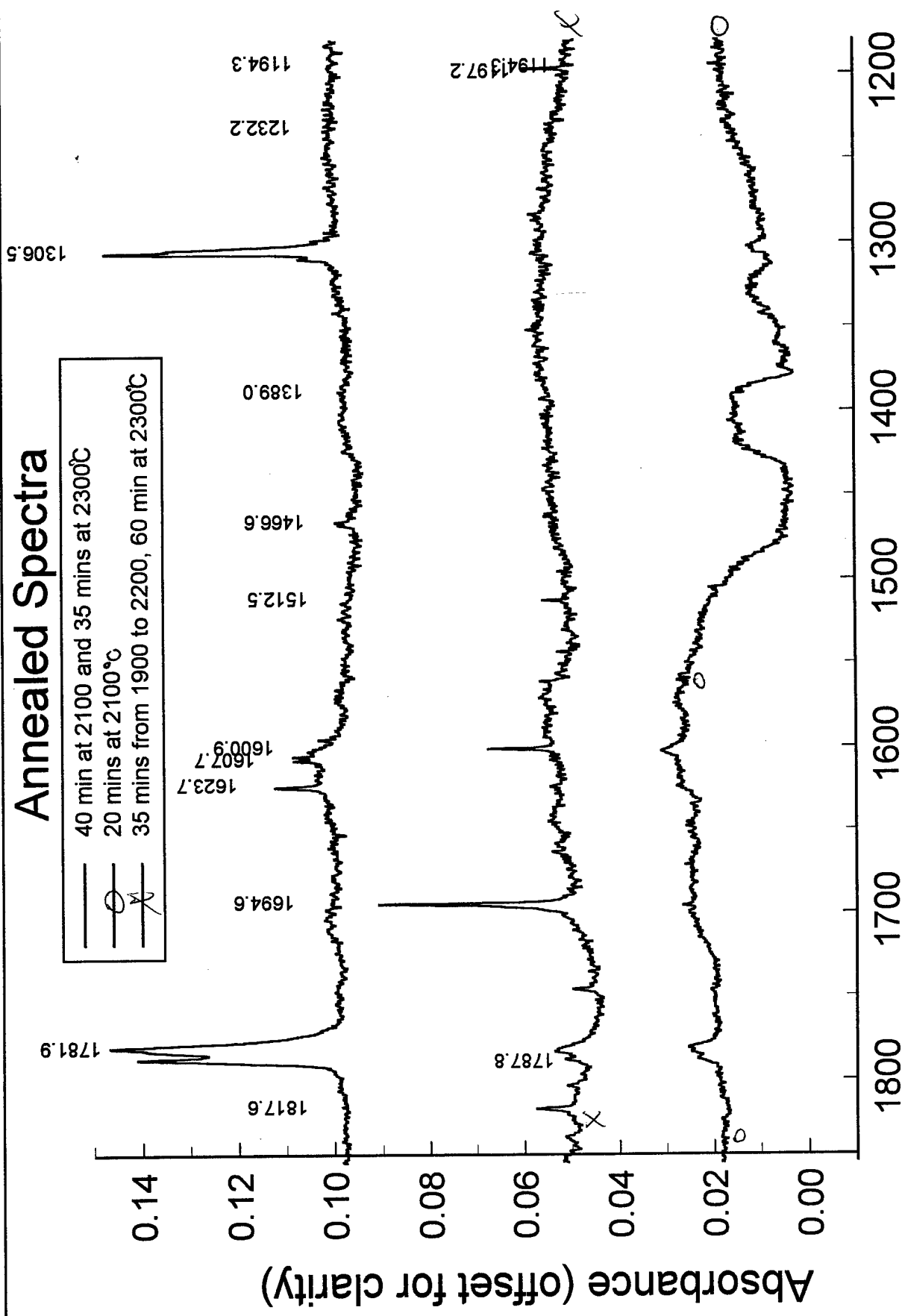

Wavenumber (cm<sup>-1</sup>)

Absorbance (offset for clarity)

## Analysis

An expression for the ratio of boron atoms to carbon atoms is below. It assumes that formation of the selected species occurs primarily through addition of one atom to a preexisting species (for example,  $B + C_6 = BC_6$  or  $C + C_6 = C_7$ ) and that the preexisting species does not have an affinity for one element over the other.

$$\frac{\rho(B_J C_{n-J})}{\rho C_n} = \frac{(n)(n-1)\dots(n-J+1)}{J!} \left(\frac{B}{C}\right)^J$$

Equation 1

In the case of  $n=3$  the assumption that  $C_n$  is formed by  $C + C_2 = C_3$  is invalid because the composition of the vapor effusing from a graphite source at 2150°C is 52%  $C_3$ , 32%  $C$ , and 16%  $C_2$ . (ref. Thorn and Winslow) Therefore the ratio of  $BC_2$  to  $C_3$  does not give a true picture of the atom composition in the system. The same is true for the ratio of  $B_2C$  to  $C_3$ . However,  $BC_2$  and  $B_2C$  can be compared to give an accurate picture of the B/C ratio.

$$\frac{\frac{\rho BC_2}{\rho C_3}}{\frac{\rho B_2C}{\rho C_3}} = \frac{\frac{(3-1+1)\left(\frac{B}{C}\right)^1}{1!}}{\frac{(3)(3-2+1)\left(\frac{B}{C}\right)^2}{2!}} = \frac{3\frac{B}{C}}{3\left(\frac{B}{C}\right)^2} = \frac{C}{B}$$

Equation 2

Therefore the ratio of  $B_2C$  to  $BC_2$  indicates the ratio of boron to carbon atoms in the system.

The ratio was made with the integrated areas of the signals in the infrared spectra for these molecules, divided by the intensity of their IR absorbance. Because  $BC_2$  reacts within the matrix during annealing, measurement of the initial B/C ratio is the most accurate. For the experiment run at the highest temperature, which produced the most carbon, the B/C ratio was 1.32. Due to the presence of measurable quantities of other carbon species in that matrix, Equation 1 was used to determine the ratio of B/C atoms from  $BC_6/C_7$  (0.79) and  $BC_3/C_4$  (0.68). Considering the overwhelming abundance of carbon relative to boron (0.958g vs. 0.005g) in the system, this design is effective in enhancing the output of boron. Future experiments will aim to increase the amount of boron available for effusion without exceeding the tolerance of the carbon rod.

Ref. Thorn + Winslow

# Ratio of Boron to Carbon Atoms

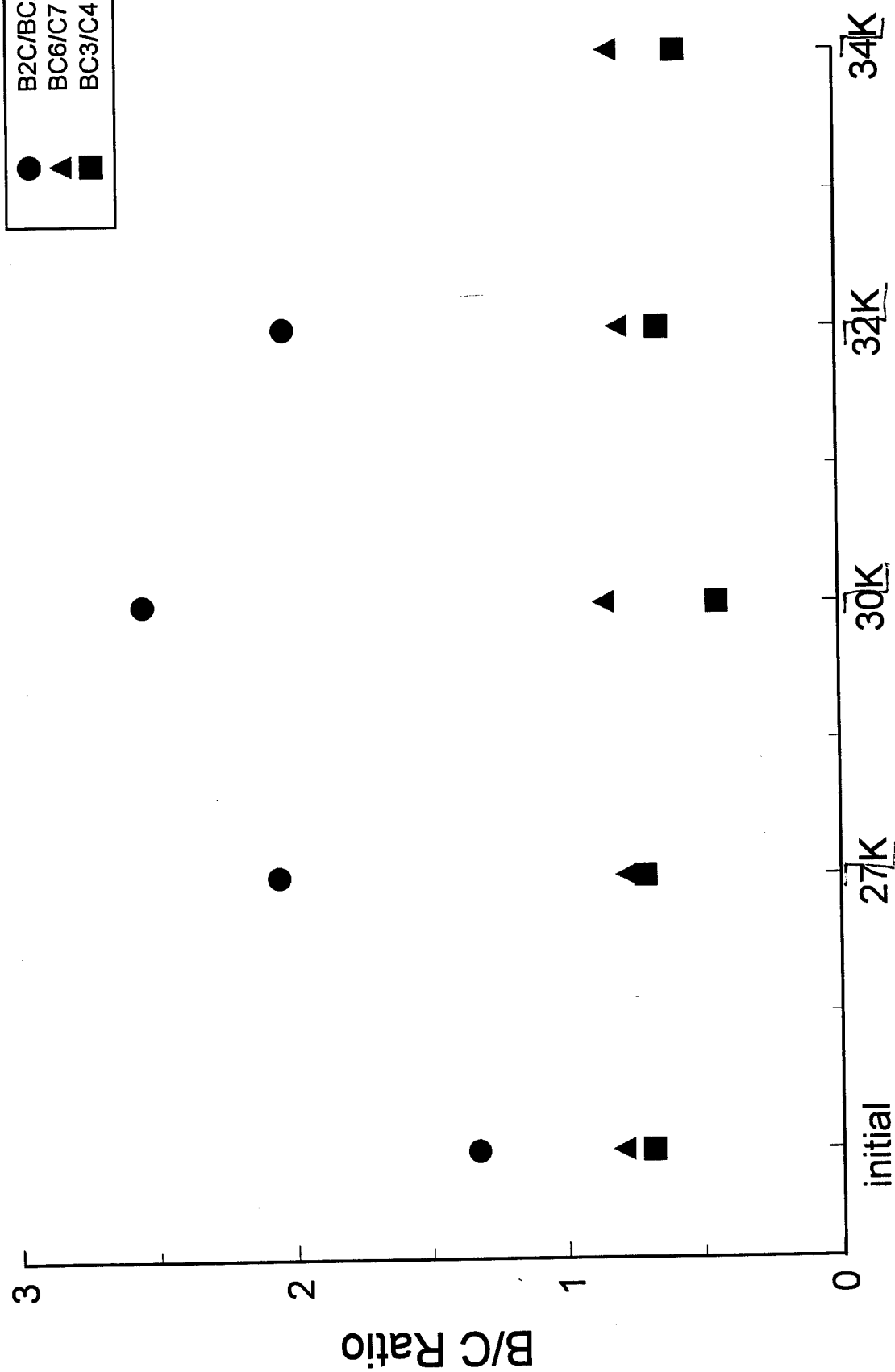
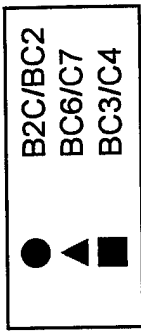

Annealing Progression

## CO as a Boron Atom Scavenger

CO is an effective scavenger of boron atoms. In the matrix which contained few carbon species, the vast majority of products were BCO and other  $B_x(CO)_y$  species. Unfortunately the absorption intensities for many of these polymers, some of which have not been conclusively identified, have not been calculated. This limits quantitative analysis of the boron atom content of the matrix.

However, with a reduced concentration of CO and less heat load on the substrate it is probable that BCO would be the primary product. With the IR intensities recently calculated by Liang and Andrews<sup>1</sup> (403 km/mol for  $^{11}B^{12}C^{16}O$ , 401 km/mol for  $^{10}B^{12}C^{16}O$ , 385 km/mol for  $^{11}B^{13}C^{16}O$ , and 383 km/mol for  $^{11}B^{12}C^{18}O$ ), it would be relatively easy to determine the amount of boron atoms present in a matrix.

Qualitative comparison to the B + CO spectra published by Burkholder and Andrews<sup>2</sup> illustrates that the number of boron atoms produced from this thermal source is comparable to that obtained from their laser ablation technique. (See overlay for comparison.) By optimizing the design of the thermal experiments, the boron atom output will likely exceed the laser technique. A high flux source of boron atoms is critical to achieving the 5% dopant concentration for an ideal HEDM.

<sup>1</sup>Liang, B. and Andrews, L. unpublished data communicated on 30 May 1999.

<sup>2</sup>Burkholder, T. R. and Andrews, L. *J. Phys. Chem.* **1992**, 96, 10195-10201. Reaction of Boron Atoms with CO. Matrix Isolation Spectra of BCO,  $(BCO)_2$ , and  $B(CO)_2$ .

From ref 2  
on previous page

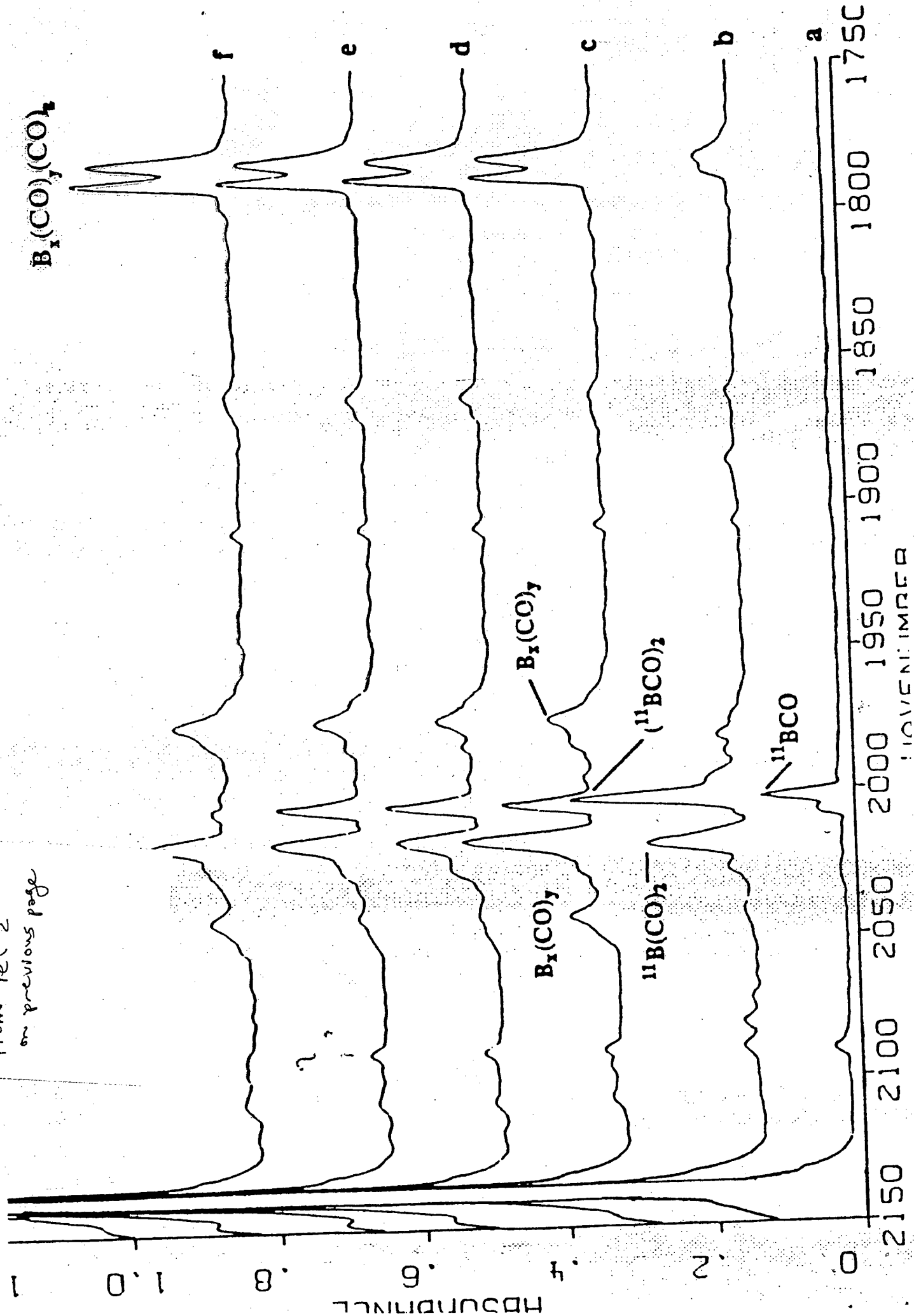

NOV 21 1968

c:\first\data\galaxy\jessiccjh03104b.igm Thu May 13 14:54:27:86 1999

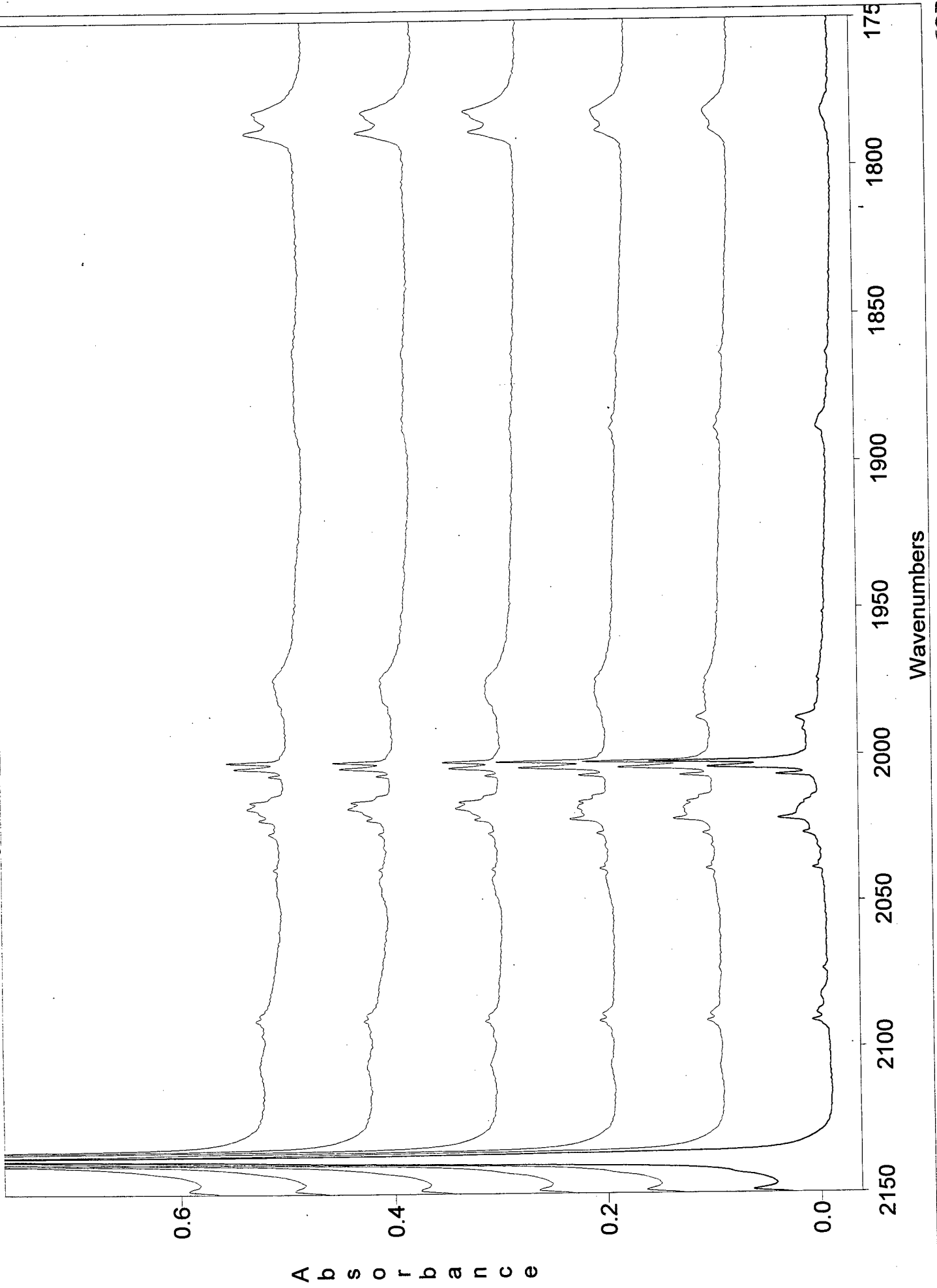

502

### Future Experiments:

Reduce the heat load on the substrate by minimizing the hole in the heat shield which protects the substrate. This should reduce the concentration of condensed species observed in as-deposited matrices.

Use boron nitride in place of carbon liner. BN is used successfully to heat aluminum, another element notorious for alloying with its container when heated.

Using IR and UV spectroscopy, the cannon design will be optimized to produce more boron atoms. If seemingly successful, the source will be probed with the mass spectroscopy system developed by Michelle DeRose and Mario Fajardo to verify the products from the cannon.

Following MS characterization, the source will be incorporated into the hydrogen matrix isolation apparatus operated by Simon Tam and Mario Fajardo to test the viability of boron atoms in solid H<sub>2</sub>.

## Conclusions

The boron cannon shows promise as a high flux source of pure boron atoms. Thus far the boron concentration from this configuration is equivalent to that observed with laser ablation.

A boron/carbon atom ratio of approximately 1 was obtained. This ratio indicates far less carbon contamination than that observed from previous thermal sources which used carbon as a container for boron. (ref. Presilla-Marquez, Larson, and Carrick, *J. Chem. Phys.* **105** (9), 1996 for example)

The approximate ratio of boron to carbon is highly dependent on the operating temperature of the cannon. An actual ratio could not be calculated for matrices produced at lower temperatures because there were not detectable levels of carbon species in those matrices.

Confirmation of Larson's  $B_2C$  assignment at  $1398.2\text{ cm}^{-1}$  for  $^{11}B_2^{12}C$ . (ref. *J. Chem. Phys.*)

ref. J. Chem. Phys. 105 (9), 1996  
← of test

CO is an excellent scavenger of boron atoms. This effect could be developed into a diagnostic to determine the boron concentration of a matrix.

## Acknowledgements

Mario Fajardo for guidance, laboratory advice, and instrument troubleshooting.

Simon Tam for laboratory assistance.

Binyoung Liang and Lester Andrews for BCO intensity calculations.

MSgt (sel) Tracy Christensen for machining parts and electronics expertise.