

ARI Research Note 2003-03

**Low-Cost PC Gaming and Simulation Research:
Doctrinal Survey**

Ronald W. Tarr and Christina S. Morris
University of Central Florida

Michael J. Singer
U. S. Army Research Institute

Simulator Systems Research Unit
Bruce Knerr, Acting Chief

October 2002



**United States Army Research Institute
for the Behavioral and Social Sciences**

Approved for public release; distribution is unlimited.

20021127 064

**U.S. Army Research Institute
for the Behavioral and Social Sciences**

A Directorate of the U.S. Total Army Personnel Command

**ZITA M. SIMUTIS
Acting Director**

Technical Review by

William Y. Pike, STRICOM

NOTICES

DISTRIBUTION: This Research Note has been cleared for release to the Defense Technical Information Center (DTIC) to comply with regulatory requirements. It has been given no primary distribution other than to DTIC and will be available only through DTIC or the National Technical Information Service (NTIS).

FINAL DISPOSITION: This Research Note may be destroyed when it is no longer needed. Please do not return it to the U.S. Army Research Institute for the Behavioral and Social Sciences.

NOTE: The views, opinions, and findings in this Research Note are those of the author(s) and should not be construed as an official Department of the Army position, policy, or decision unless so designated by other authorized documents.

REPORT DOCUMENTATION PAGE

1. REPORT DATE: October 2002		2. REPORT TYPE: Final		3. DATES COVERED: January 2001 – December 2001	
4. TITLE AND SUBTITLE: Low-Cost PC Gaming and Simulation Research: Doctrinal Survey				5a. CONTRACTOR OR GRANT NUMBER:	
				5b. PROGRAM ELEMENT NUMBER: 0622785	
6. AUTHOR(S): Ronald W. Tarr & Christina S. Morris (University of Central Florida), and Michael J. Singer (U.S. Army Research Institute for the Behavioral and Social Sciences)				5c. PROJECT NUMBER: A790	
				5d. TASK NUMBER: 202A	
				5e. WORK UNIT NUMBER: H03	
7. PERFORMING ORGANIZATION NAME(S) AND ADDRESS(ES) Institute for Simulation and Training University of Central Florida 3280 Progress Drive Orlando, FL 32826				8. PERFORMING ORGANIZATION REPORT NUMBER:	
9. SPONSORING / MONITORING AGENCY NAME(S) AND ADDRESS(ES): U.S. Army Research Institute for the Behavioral and Social Sciences 5001 Eisenhower Avenue Alexandria, VA 22333-5600				10. MONITOR ACRONYM: ARI	
				11. MONITOR REPORT NUMBER: Research Note 2003-03	
12. DISTRIBUTION / AVAILABILITY STATEMENT: Approved for public release; distribution is unlimited.					
13. SUPPLEMENTARY NOTES:					
14. ABSTRACT (Maximum 200 words): The U.S. Army Simulation, Training and Instrumentation Command (STRICOM) established a program investigating novel techniques for low-cost/complexity training devices. The U.S. Army Research Institute for the Behavioral and Social Sciences contributed to this program by supporting the investigation of doctrinal issues in low-cost personal computer (PC) gaming. The Institute for Simulation and Training at the University of Central Florida developed an approach for defining game parameters and surveying subject matter experts (SMEs) on doctrinal correctness of game experiences. Doctrinal correctness combines and interacts with cognitive skills and decision-making skills gains in complex ways that make the selection of games for reinforcing training through training a complicated trade-off. Based on prior work, PC games were selected for Infantry and Armor tasks and evaluated for application and doctrinal correctness. The evaluations for the Infantry aspects of <i>Rogue Spear: Covert Ops</i> [™] indicated that the game could be used for tactical movement, tactical scenario, and room clearing exercises. The evaluation of <i>Steel Beasts</i> [™] were positive in terms of gunnery elements, but there were sufficient doctrinal errors that the overall game was judged to not be useful. The results of this and other efforts indicate the potential usefulness of commercially available off the shelf PC games, although further studies are needed in order to establish guidelines and characteristics for integrating selected aspects of games into ongoing instructional approaches.					
15. SUBJECT TERMS: PC Games, Low Fidelity Simulation, Synthetic Environments, Low-Cost Simulation, Analytical Evaluation .					
SECURITY CLASSIFICATION OF			19. LIMITATION OF ABSTRACT Unclassified	20. NUMBER OF PAGES	21. RESPONSIBLE PERSON (Name and Telephone Number) Michael Singer 407/384-3993
16. REPORT Unclassified	17. ABSTRACT Unclassified	18. THIS PAGE Unclassified			

Research Note 2003-03

Low-Cost PC Gaming and Simulation: Doctrinal Survey

**Ronald W. Tarr,
Christina S. Morris**
University of Central Florida

Michael J. Singer
U.S. Army Research Institute

**Simulator Systems Research Unit
Bruce Knerr, Acting Chief**

**U.S. Army Research Institute for the Behavioral & Social Sciences
5001 Eisenhower Avenue, Alexandria, Virginia 22333-5600**

October 2002

**Army Project Number
2Q262785A790**

**Personnel Systems and
Performance Technology**

Approved for public release; distribution is unlimited.

FOREWORD

Personal computer and video games have shown dramatic improvements in processing speed and graphics capability. As a result, the game representation of military activities has increased in realism, leading to questions about their potential use in Army training. These questions focus on identifying and quantifying the effects of games and their use in skill acquisition, retention, and transfer of training to Army tasks. The research reported in this note addresses whether or not exemplar military games provide doctrinally correct approaches to conducting military individual and collective tasks. The work builds on previous STRICOM efforts to identify a specific approach for evaluating PC games in terms of ease of application and appropriateness for incorporation into Army training. The findings from this research are intended to be used to evaluate and recommend PC games for incorporation in Army institutional and field training programs, based on their characteristics and instructional value.

The U.S. Army Research Institute for the Behavioral and Social Sciences, Simulator Systems Research Unit, conducts and sponsors research with the goal of providing information that will improve the effectiveness of training simulators and simulations. The work described here is a part of ARI Research Task 202a, VERITAS - Virtual Environment Research for Infantry Training and Simulation. This work was performed by the Institute for Simulation and Training, University of Central Florida.



STEPHEN L. GOLDBERG
Acting Technical Director

ACKNOWLEDGMENTS

This work could not have been conducted without the help of many subject matter experts at Ft. Benning, TRW, the University of Central Florida Institute for Simulation and Training, and the Simulation, Training and Instrumentation Command.

LOW-COST PC GAMING AND SIMULATION RESEARCH: DOCTRINAL SURVEY

EXECUTIVE SUMMARY

Research Requirement:

The U.S. Army Simulation, Training and Instrumentation Command (STRICOM) has been investigating personal computer and video games, generically referred to as PC games, as low cost/complexity training devices. One aspect of the program was to determine whether low-cost PC games could be used as viable training/educational interventions that achieve measurable learning outcomes. That training analysis identified general cognitive skills that were addressed by a wide range of games. A review of the cognitive skills analysis identified the doctrinal correctness of game parameters and playing patterns as critical to effective transfer of skills from games to military activities. The current effort assessed the doctrinal correctness of two PC games (used in the previous investigation), as a step toward providing methods for evaluating and recommending PC games for incorporation in Army institutional and field training programs based on game characteristics and instructional value.

Procedure:

Two PC games, previously analyzed for potential application in military skills training, were investigated for doctrinal correctness within potentially applicable occupational specialties. A portion of the previous analytical process was adapted for conducting subject matter expert evaluations addressing the doctrinal correctness of armor and infantry off-the-shelf games for training. The games were strategically mapped into detailed documents that portrayed game elements, options, and missions in a clear fashion that allowed canned game scenarios to be mapped to military training procedure, protocol, and fidelity. These materials were then presented to available subject matter experts in a focus group type of evaluation, moderated by the researcher, and directed toward attaining information on the game's potential for training or practice in the context of doctrinal correctness.

Findings:

Overall, *Rogue Spear: Covert Ops*[™] (an infantry or special operations game) was judged as providing users with a realistic and doctrinally correct simulation of many facets of covert operation missions. The infantry SMEs especially liked the opportunities to practice doctrinally correct aspects of room and building clearing; for example formations at the entrance to a room, and the ability to move systematically throughout a building. *Rogue Spear: Covert Ops*[™] also

offered an excellent multiplayer cooperative capability that was judged as enabling the practice of team skills among individuals. An evaluation of Steel Beasts™ (a tank battle game) resulted in the SMEs deciding that despite the many strong elements in the game, it had facets that could potentially result in negative training or cause doctrinal confusion on the part of soldier students. Discussions about pending update releases of the game (which would include M1A2 simulations) were encouraging, as that equipment was the basis for many negative comments.

Utilization of Findings:

The U. S. Army will employ PC gaming technology for training, rehearsal, and evaluation both in local and distributed formats. A usable, easy to implement process could prove to be extremely beneficial to military agencies that were considering integrating commercial off-the-shelf (COTS) PC-based synthetic environments into training programs. The game mapping process described in this effort, as well as the evaluation process, are techniques that would be effective in identifying what game elements are candidates for training applications. Clearly elements of the examined games can be useful, especially when organic mission editors can be used to tailor the relevant portion of the games to satisfy real training requirements. Feedback from the SMEs indicates that with a mission editor and a “guide for instructors” the games would be useful additions to training programs. Games can provide a more engaging instructional approach than is currently being used at the installations with which the SMEs are familiar. The potential usefulness of COTS PC games should be studied further with soldiers engaged in training programs, and assessed against training requirements.

LOW-COST PC GAMING AND SIMULATION: DOCTRINAL SURVEY

CONTENTS

	Page
Introduction.....	1
PC Gaming and Training Literature Review	2
Project Objective.....	4
General Method	4
General Procedures	5
Materials	5
Experiment 1- Infantry Participants.....	6
Infantry Evaluation Procedures	6
Infantry Results Summary	7
Experiment 2-Armor.....	7
Procedure—Armor Analysis.....	8
Armor Results Summary	9
Discussion.....	10
Conclusions.....	11
References.....	12

Introduction

The U.S. Army Simulation Training and Instrumentation Command (STRICOM) established a research program investigating novel techniques for low cost/complexity training devices, design strategies for improving the acquisition and retention of individual and team skills, and measuring the effectiveness of instructional features. Under this effort, the University of Central Florida (UCF), Institute for Simulation and Training (IST) began researching low-cost Personal Computer (PC) gaming and simulation to determine whether low-cost video games could be used as actual viable training/educational interventions that achieve measurable learning outcomes. The results of that research provided a direct link between the simulation and training industry and the video game industry. The conclusions provided guidelines for the inclusion of new cost-effective game media within military training that could substantially increase learning efficiency and performance.

The initial research investigated and documented the learning potential of PC-based games for the larger simulation and training community. The research focused on military training for individuals and teams, primarily in the area of cognitive skills, such as procedures, planning, decision-making, etc. The IST research effort analyzed data from PC-based gaming subjective responses and developed basic cognitive templates that use game features and options to select various PC-based games. Additionally, the data provided initial support for an internalization/externalization gaming theory (Morris & Tarr, 2002).

The effort documented in this report used subject matter expert (SME) evaluations to assess the doctrinal accuracy of PC games for training. The evaluations were conducted by defining game parameters and environments and then obtaining the subjective opinions of SMEs regarding existing doctrinal policies or tactical techniques within the activities of the game. IST used subjective SME reports to establish the procedure, instruments, and techniques essential to measure the degree of doctrinal correctness. To clarify the concept of doctrinal evaluation, the following examples are offered:

- The typical approach for dismounted soldiers moving through urban terrain is to use bounding overwatch while moving close to walls and maintaining adequate cover. If a game did not support teams, one concern would be that proper bounding overwatch could not be reinforced in the trainees. If the game rewarded players for rapid movement rather than cautious and covered approaches, the game might create inappropriate tactical patterns in the users that could be detrimental if transferred to field exercises.
- Deviations in weapons systems capabilities and military symbology might also lead to incorrect transfer and inappropriate tactical doctrine during operations.
- Interaction between the players and the Semi-automated Forces (SAF) or Artificial Intelligence (AI) might lead to lowered or narrowly patterned opposing force expectations by the trainee.

There are, however, multiple dimensions to PC games. For example, they might train or reinforce the right kinds of cognitive skills for a small unit leader but do so in a context that reinforces incorrect doctrine. One consequence might be a game-induced error in tactics on the battlefield, although the leader gained excellent decision-making skills by playing the game.

PC Gaming and Training Literature Review

Research conducted in the early part of the decade indicated that computer games and simulations were low on fidelity, interface, and immersion dimensions (Thurman & Mattoon, 1994). Compared to the PC games of today, they could not faithfully represent the real world nor did they have very natural interfaces, and the feeling of being immersed in the simulation was accomplished only through imagination. All that has changed with the significant strides we have seen in the development of graphics and animation software, AI, computer interfaces, and networking. Just as graphics and computer interface advances have produced more realistic simulations of the physical world, AI is resulting in more realistic modeling of game characters. AI at the human level can be applied to tactical enemies, partners, support characters, and even units of individuals, such as a platoon (Laird & van Lent, 1999).

The availability of networked simulation technology has allowed the training of general team skills such as aircrew resource management behaviors (Baker, Prince, Shrestha, Oser, & Salas, 1993), air combat (Huddleston, Harris, & Tinsworth, 1999) and commercial barge and tugboat crew skills (Salopek, 1998). This provides mission rehearsal capability which can be embedded where appropriate, to provide training anywhere, anytime. Commercial off-the-shelf (COTS) personal computer and console games (referred to generically as PC games) now also conform to many technology and development-based standards such as being Distributed Interactive Simulation (DIS) Compliant, so they may be linked together in advanced training scenarios across the spectrum of operations.

PC Games

The PC gaming and simulation industry, largely driven by recent technology advances and consumer economics, has dramatically driven cost down while improving the quality and realism of games and desktop simulation technologies. The cost-capability curve available today was unheard of just two years ago. Several agencies, including different branches of the US military, are exploring the possible use of PC games as a supplement to some aspects of training. The initial investigations are focused on training that uses expensive real world exercises, or costly simulation technology applications such as head mounted display (HMD) virtual environments. Specific features of PC games are also being investigated as practice and feedback alternatives or classroom enhancements. The goal is determining low-cost training alternatives for assignments that don't easily allow required job or skill training, such as assignments to Bosnia or on board ship.

Recent advances in PC technology, such as high-speed processors, expanded memory, and high-performance video cards with 3D capability have made high quality synthetic environments technology inexpensive. Additionally, COTS game developers' use of reputable

military data sources for game models have made these games increasingly attractive to the military for inclusion in training (Coleman and Johnston, 1999). For example, there has been strong acceptance of the Center for Naval Education and Training (CNET) plans to implement a formal training program around the Microsoft Flight Simulation 98/2000tm software (Dunlap & Tarr, 1999; Koonce & Bramble, 1998). The military is also evaluating other games as potential low-cost flight simulators (Coleman & Johnston, 1999).

Applying PC Games

Games and simulations have always been a part of education and learning strategies, especially in military training. PC games provide the opportunity for knowledge or skills to be acquired and/or practiced in a variety of settings and contexts so that they may be understood, integrated, and accessible in future situations (Ruben, 1999). This type of environment is important today because a very large number of military deployments and Operations Other than War (OOTW) cause military personnel to move out of their basic warfare operations and into situations where there is little or no way to keep tactical skills, especially cognitive skills, current.

Educational games have also been favorably compared to classroom instruction for the teaching of social studies, math, language arts, logic, physics and other sciences (Randel, Morris, Wetzel, & Whitehill, 1992). Simulation building games are suggested to be an effective training tool for teaching urban geography and urban planning because they add motivation to the learning process (Adams, 1999). In other game types, players are engaged in competitive interactions in which they follow a set of rules to achieve specified goals that depend on skill and often involve chance and are potentially highly engaging and motivating. Business simulations and scientific simulations were found to be acceptable teaching tools in classroom settings (Ruben, 1999). Commercial uses of simulation are prominent in the medical community, NASA, nuclear power, and commercial aviation (Thurman & Dunlap, 1999). Additionally, the military uses the majority of simulator-based training programs. PC games have also been shown to enhance soldiers' decision-making skills by providing practice with variation (Riddle, 1997). Similarly, (Pillay, Brownlee, & Wilss, 1999; Ricci, Salas, & Cannon-Bowers, 1996) demonstrated that players practiced complex cognitive processes such as interpreting explicit and implicit information, inductive reasoning, metacognitive analysis, and problem solving. Homan (1998) also suggested that low-cost low-fidelity PC aviation simulations can be used to enhance pilots' situational awareness.

PC games have an array of applications and provide easy and engaging opportunities for practice and skill retention of those more abstract but critical thinking and decision-making skills. Games and simulations may not appear to be similar to instructional techniques, but as learning environments they have overlapping characteristics. Both are examples of experiential instructional methods in that they are interactive and foster active learning (Ruben, 1999). According to Brown (1999), both require a temporary suspension of disbelief as participants accept a false situation as temporarily real. Their differences lie in how players participate. In training simulations, players participate in situations or processes in order to learn about specific real-world settings or procedures. Recent studies have suggested that PC simulation games can

produce a general transfer of cognitive skills that have application to a wide variety of domain-specific tasks. Other studies have used recent PC games for conducting psychological research on the cognitive processes involved in problem solving, strategy development (Gonzales & Cathcart, 1995) and changes in neural maps (Tallal, Miller, Bedi, Byma, Wang, Nagarajan, Schreiner, Jenkins, & Merzenich 1998).

In summary, PC games now have the capability to assist learning, transfer, and performance in a variety of domains, including substitution for real world training requirements. Since PC-based technology is at a point where human inclusion or immersion is fundamental, the capability and feasibility of applying PC games to enhance performance, training, and educational utility is evident. The question becomes how to select and use specific games or portions of games for specific training requirements.

Project Objective

In order to apply PC COTS games to military training one needs an analytical approach to analyze and extract components of PC games for customized application capability. This effort addressed one part of this need by investigating the development of one component of an iteratively developing systematic model for analysis and certification of low-level COTS synthetic environments for training (Morris & Tarr, 2002). Obviously, time and resources were too limited for full-scale training program development investigations. Therefore, a general analytic approach was used to identify and investigate the games potential alternative learning value to live or expensive large-scale simulation applications. The eventual goal is a modeled process that researchers and developers could use to reduce costs of new instruction, software development and non-recurring systems engineering.

The immediate objective for this effort was to focus on the evaluation of doctrinal correctness or veracity of potential PC games by conducting interviews with Army standards SME. During this process, training application and usefulness were also assessed as resources and time allowed. A portion of the previous validation model process was adapted for conducting SME evaluations regarding the doctrinal accuracy of armor and infantry off-the-shelf games for training (Morris & Tarr, 2002). The analytic evaluations were expected to identify and define specific game parameters and environments, and then obtain the subjective SME opinions regarding correctness or veracity of the games in terms of existing doctrinal policies or tactical techniques.

General Method

Based on prior analytic efforts aimed at determining the range and level of possible skills and knowledge trained by PC COTS games (Morris & Tarr, 2002), two different domains were selected for analysis. These were dismounted infantry and mounted armor operations.

Rogue Spear: Covert Ops™ was investigated primarily because it addresses infantry squad and fire team activities in an urban environment, although other settings can be played as well.

The coordinating draft of FM 90-10-1, The Infantryman's Guide to Modern Urban Combat, was used as the basis for evaluating doctrine in the Rogue Spear: Covert Ops™ PC game.

For the armor assessment, Steel Beasts™ was selected, primarily because the mission editor enabled demonstration scenario development. Steel Beasts™ is an armor simulation that is in continual development. Initial development of the game in 1998 apparently lacked many of the features that are considered today as standard. For example, there were no options to have 3D accelerated graphics enabled, the sound quality was minimal at best, and it had a poor interface. The game does have several beneficial features that led to use in this work. Primarily, Steel Beasts™ is still being supported, with regular updates from the developer. Maintaining contact with the developers was easy and their responses were informative. External evaluators, such as the on-line tank-simulation community, are strong promoters of Steel Beasts™ and they provided needed and timely information (typically through internet game sites).

General Procedures

In order to attain detailed SME responses and to make the evaluation process as easy to accomplish as possible a focus group type of evaluation was employed, moderated and directed toward attaining information on every angle of the game's potential. Although some of the questions do require different kinds of responses, the formats were made as consistent and direct as possible.

In order to insure SME understanding of all game functions for complete evaluation of their usefulness for military training, the game flowcharts were used. These detailed all of the game's possible options, scenarios, elements, and combinations, as noted below. The flowcharts provided a visual rendering for use in comparing the game capabilities to military requirements, tactics, and doctrine.

The SME respondents were also presented with the canned game scenarios which demonstrated functions such as mission planning, training segments, and game options review. Using these prepared, canned scenarios and walkthroughs allowed the researcher to present the characteristics and features in a game context without requiring the SME to know how to play the game. In this way, the SME could determine just what doctrinal aspects the game supported during play.

Materials

In order for SMEs to analyze aspects of the target games for doctrinal correctness or veracity, explicit aspects of the games had to be clearly presented for reference to specific military tasks, tactics, and protocol. Therefore, the games were initially strategically mapped into detailed flowcharts that clearly portrayed game elements, options, and missions. These flowcharts were created using Microsoft VISIO™. The flowcharts were developed by analyzing the provided gaming manuals, embedded tutorials, and training scenarios to delineate the capabilities and note the command sequences required for use. These flowcharts were also used to create canned game scenarios that mapped to military training, procedures, and protocol. The

game scenarios were developed under the direction of in-house SMEs working with currently available Army manuals. For example, reviewing the game flowcharts enabled the determination of available squad sizes, briefing and debriefing capabilities, AI options, weapons options, opposing force options, etc. The flowcharts were used in conjunction with the game scenarios to review designed game components for SME analysis of doctrinal correctness.

The hardware and software used for the infantry and armor assessments consisted of a portable projection system, projection screen, wireless keyboard/ mouse, the game PC, PC speakers, installed Windows 98, internal ASUS V8200 video card, laptop, Rogue Spear: Covert Ops™ CD, Steel Beasts™ armor CD, specific canned scenario demonstration video (and back up), camcorder with tripod. An informed consent, demographics and expertise form (Appendix A), mission relevant forms, game options and elements forms (Appendix E provides the Steel Beasts™ materials as an example) were used in the assessment. Minimum requirements for the game are no less than K6-2™ (or Intel Pentium II™) 400Mhz with at least 128 megabytes of RAM, and a TNT2™ or comparable video card. Keyboard and mouse are essential for most of these games, including Rogue Spear: Covert Ops™, and Steel Beasts™.

Experiment 1- Infantry Participants

Two SMEs were used as participants for the infantry. The first reported that he had high familiarity with infantry doctrine (18 years), high familiarity with general military expertise (23 years), was never a platoon leader or company commander, but moderately familiar with Special Operations (12 years) and urban operations (6 years). He never played games and his initial opinion is that there are “no” benefits to using COTS PC games for military training but some possible value added for advanced technologies in military classroom setting. The second infantry SME reported high familiarity with infantry doctrine (30 years), high familiarity with general military expertise (30 years), high experience as platoon leader (7 months), high experience as company commander (3 years), and was moderately familiar with Special Operations (1 year) with no experience with urban operations. Additionally, he was highly familiar with the combat training center (3 years). The second SME had no opinion regarding PC games.

The coordinating draft of FM 90-10-1, The Infantryman's Guide to Modern Urban Combat, was used as the basis for evaluating doctrine in the infantry game. This application was combined with the game maps, and the assessments were conducted via observation of dialogues.

Infantry Evaluation Procedures

The Infantry SMEs completed the informed consents, demographics questionnaires (Appendix B), and then viewed the tactics oriented canned scenarios followed by the game walkthrough of planning phases, options, elements, and other potential missions. The SMEs addressed all potential doctrinally effective and ineffective components, including potential solutions possible from game alterations. Finally, the SMEs completed the specific

questionnaires and concluded their comments regarding the observations and interactions with Rogue Spear: Covert Ops™ environments, options, and elements.

Infantry Results Summary

The SMEs generated many comments during the evaluation (see Appendix B). The comments have been condensed and merged for a clear summary presentation. The biggest problems that the SMEs had were with the context of the mission, which are doctrinal violations. Primary among these were comments about who, what, where, when, and why in the introduction.

- A 9-man infantry squad would be used to clear a 5-room building. A platoon would be used to clear 2-3 buildings (FM 90-10-1, Jul 2000). The PC game used a 4-man team (fire team size) and the demo mission had them clearing a series of buildings, which is not realistic.
- A 4-man fire team cannot support itself. Once a team clears an area some element must remain in place or another must relieve it in place.
- It is valid to use notional support elements, but their use and role must be addressed during the introduction. In addition, there must be a clear order [Rules of Engagement (ROE)/Rules of Interaction (ROI)] regarding hostages.
- It is normal to use “weapons tight” or ROE -restrictive (return fire only) when encounters with hostages are expected.
- The focus for a particular scenario snippet from the game must be narrow and clearly defined. For example, some of the movement tactics (e.g., entry techniques) and character movements were incorrect (e.g., weapon positions).

SMEs also objected to aspects in the kit selection, for example a full metal jacket round is always used because a hollow point is against the Geneva Convention.

The SMEs concluded that the game could be used for training in spite of the doctrinal problems, as long as trainers attended to those negative aspects present in the training vignette. However, additional features would be needed to enhance training. For example, there is a need to capture (hear) dialogue between squad members, especially during the After Action Replay. Also, tactical movement in the game is relatively realistic if it is made clear that participants have an additional support team or platoon in an overwatch capacity (see comments, above). Overall, the infantry SMEs especially liked the opportunities to practice aspects of room and building clearance, the ability to form the "stack" at the entrance to a room and moving systematically throughout a building. The consensus was that Rogue Spear: Covert Ops™ provides users with a realistic simulation of many facets of covert operation missions. Rogue Spear: Covert Ops™ also offers an excellent multi-player cooperative capability to exercise team skills among individuals. Both SMEs were open to using the game in an early training stage for new troops.

Experiment 2-Armor

For the Armor review, challenges in scheduling and new policy on use of soldiers for data collection resulted in our not having access to personnel at Ft. Knox; one issue was the general heightened security alert as a result of the incidents on September 11, 2001. Therefore,

local SMEs were engaged. These were retired military armor officers who were currently employed by the Army for their expertise on Armor operations. Three armor SMEs took part in the armor review. In addition to a strong armor background, each is a retired Army colonel (O-6) with significant military experience. Each also has active duty training credentials and credentials based on their current position as government contractors working on training simulation issues for Project Manager for Combined Arms Tactical Trainers (PM CATT) and Project Manager for Warfighters' Simulation. One SME had served as commander of the opposing forces at the National Training Center — undoubtedly the U.S. Army's most rigorous training environment for armored and mechanized infantry forces — and later as Commander of an Armored Training Brigade at Ft. Knox. Another served as the Training and Doctrine Command System Manager for the Combined Arms Tactical Trainer and assisted in the detailed collective task analysis of armor crew tasks as part of the Training Exercise Development System study. The Training Exercise Development System is the training support package for the Close Combat Tactical Trainer (CCTT) developed by PM CATT to help unit commanders efficiently allocate collective training tasks to structured CCTT training exercises.

The discussion used revised mission scenarios developed specifically by using Steel Beasts™ mission editor to incorporate Platoon Reaction Exercises from the Tank Tactical Tables in FM 17-12-1-2 (Tank Gunnery). Specifically, scenarios for missions I-2 (Engage Multiple Targets) and I-4 (React to Ambush) have been incorporated into the game. The incorporation of tactical table scenarios had the potential to offer some doctrinal consistency in training value. Since the Tank Tactical Tables were applied to the evaluations for armor SMEs, there were no forms and the assessments were conducted via observation of dialogues.

Procedure—Armor Analysis

The SMEs completed informed consents. Then the expert gamers provided a basic overview of the Steel Beasts™ game functionality and capabilities. The evaluation began with a brief discussion of infantry findings and the rationale for selecting Steel Beasts™. Gamers also explained the capability of the mission editor, and the SMEs were told that it was a primary reason Steel Beasts™ was selected, that the game is continuously being upgraded and developers will release an M1A2 version in the spring. The Armor demonstration focused on the gunnery portion of the simulation because a consensus agreed that no simulation currently available to the public could accurately reflect the driving tasks and activities of the tank. The fact that the simulations were not developed with military application in mind was acknowledged. It was also made clear that realism has been sacrificed for playability or “fun factor.”

An overview of the Steel Beasts™ game, missions, and capabilities (including the mission editor) was briefed and discussed with the SMEs. Introductory comments were made regarding other uses of PC off-the-shelf games in training environments and the objective of this project. The introduction stressed the goal of identifying aspects or elements of the game that might have doctrinal utility, or contribute to doctrinal ineffectiveness in individual or collective training. Then the Tactical Table missions incorporated in the game were demonstrated. Two expert gamers served as a tank section, as the TC and gunner of the same tank or as opposing tankers while key tactics were demonstrated. This assessment also consisted of a strategic mix of game

research, game diagnosis and mapping, design assessment, evaluation of potentially applicable tactics, and examination of relevant doctrine references. Reaction exercises from the Tank Tactical Tables in FM 17-12-1-2 were included in the developed demonstration.

Armor Results Summary

A feature of Steel Beaststm that was considered beneficial by the SMEs was its mission editor, which allows the user to easily and quickly create a mission. The interface for this function was determined to be intuitive, and allows for replication of current military training procedures. The unit choices were considered well balanced because users are given the opportunity to select anything from an M1A1 to a Russian T-72 or an M2A2 Bradley. The mission editor is unique and it provides Steel Beaststm with its biggest advantage because the user can manipulate the game to fit the practice and training session needs.

During the demonstration of Steel Beaststm, SMEs noted that the tracking and lasing (sighting with a laser) seemed jerky. The deficiency was traced back to the joystick being used, the MS Sidewinder Force Feedback. Also noted as a problem was the manual switch between HEAT round targeting and sabot round targeting that Steel Beaststm required. The SMEs weren't impressed with the targeting reticule Steel Beaststm provided, nor with the fact that Steel Beaststm offered only the M1A1, and not the more modern M1A2 or M1A2 Special Equipment Package. Furthermore, the SMEs noted that during the gunnery exercise, after a tank had been hit and disabled, it shouldn't disappear but should smoke and stop moving.

Although Steel Beaststm does not include the modern M1A2, it was concluded that it was a good simulation when its gunnery aspects are considered. During analysis, a strong user base was noted, and the developers were accessible and responsive. Multiplayer capability over the Internet made battles easy to arrange and play. In addition, these features contribute to cooperative play. It was determined from the Steel Beaststm environment demonstration preparation that the multiplayer function allowed more than 20 users in the same mission simultaneously. Two users can be in the same tank at the same time, one as the Tank Commander and one as the gunner. Under optimal conditions, eight people would play a mission as one tank platoon of four tanks, with a separate Tank Commander and Gunner for each tank. During testing, however, we were unable to have a full platoon. It was during this testing phase that the computer's AI inadequacies were noted (in comparison to that of a normal human). (It was also noted by the gaming demonstrators that according to doctrinal guidelines and the context of the game under study, the number of players required to portray demonstrable missions varied. During train up of initial game-crew demonstrators, several issues tend to complicate the evaluation potential. For example, after a group of two or more individuals had been practicing a particular game together, adding an extra player disrupted the mission flow. Overall, teaming became more difficult as those early players had gained a situational awareness that new players didn't have.)

Steel Beaststm has its drawbacks. First, the options are very limited, as mentioned above, because only the M1A1 and the German Leopard 2 tanks are available. Other users have made

modifications to these tanks in order to reflect other well-known models but what they have affected is little more than a different paint job or "skin."

The evaluation of Steel Beasts[™] resulted in the SMEs deciding that despite the many strong elements in the game, it had facets that could potentially result in negative training or cause confusion on the part of soldier students. The greatest disadvantage of the game was the lack of the A1 armor system and the game's limited mission planning capability, unless the mission editor was employed. The SMEs had been informed that the same development team is working on Steel Beasts II[™], which would include the M1A2, and that inclusion was perceived as necessary for doctrinal effectiveness in training according to all SME evaluations. Specific comments from the SME discussions are provided in Appendix D.

Discussion

The objective for this project was to examine the doctrinal correctness of at least two selected COTS PC games in terms of Army Standards, to further establish the actual training utility for meeting training requirements, as a follow on to the initial study. A usable and easy to implement process was attempted, consisting of a straight forward analysis of game characteristics and development of an exemplar scenario. This information was used in focused group discussions with available SMEs to investigate doctrinal correctness. This approach should be considered as an option that could prove to be extremely beneficial to military agencies that are considering integrating COTS PC-based synthetic environments into training programs. The key in the approach is describing and demonstrating game characteristics, and producing a relevant demonstration scenario for SME evaluation.

The difficulty of analytically assessing actual military training needs might also affect future analysis. As contractors and ex-military personnel, obtaining up-to-date documentation specific to the potential of the game under study was difficult. In order to understand the games and their usefulness for military training, the games were mapped into flowcharts depicting characteristics, features, and options. In order to interpret these maps, equally detailed military training needs were necessary. Early in the analytical process, it was noticed by our resident SMEs that the tactics used for these scenario demonstrations were somewhat outdated, both in the games and in terms of the dates of the available documents. Also, the in-house SMEs were aware of several new techniques for urban terrain and special operations use of smaller teams that were not reflected in the games or in the available Army manuals.

The consensus of the SMEs, both in-house and Government provided, was that the Infantry Game, Rogue Spear: Covert Ops[™] could be used for relatively doctrinally correct tactical movement, tactical scenario, and room clearing, although other elements had some drawbacks. As to the armor game, although the current edition of Steel Beasts[™] does not include the modern M1A2, it was considered a good simulation when its gunnery aspects were considered solely. However, the evaluators believed that there was a sufficient number of small doctrinal errors in Steel Beasts[™] that the overall game was not useful. They indicated that establishing a tie in to the collective tasks from Automated Systems Approach to Training database with specific aspects of the game could be a way to overcome the problem.

Conclusions

The potential usefulness of COTS PC games needs to be studied further with actual clinical trials of soldiers being used and assessed against actual training requirements. The game mapping process developed in this effort is one technique that could streamline such efforts and add to the effectiveness in identifying what PC COTS games elements are viable candidates for inclusion in training. Clearly elements of the studied games are useful, especially when organic mission editors can be used to tailor the relevant portion of the games to satisfy real training requirements. Feedback from the selected SMEs indicated that with mission editors and a “guide for instructors” certain aspects of the games would be useful and might provide more engaging instructional approaches than are currently used.

The authors do not advocate using a gaming environment as is. Instead, instructors should integrate strategically evaluated and designed game features and components within an instructional design approach for specific training instances such as classroom enhancement aids, low cost complimentary practice missions, and demonstration training. The processes used in this and previous related efforts (Morris & Tarr, 2002) are initial and exploratory, addressing the wide range of evaluations that are necessary before incorporating any product into a training program. Given the visual and game entertainment orientation of our country, PC games can contribute as part of a total training system.

References

- Adams, P.C. (1999). Teaching and learning with SimCity 2000. *Journal of Geography*, 97, 47-55.
- Baker, D., Prince, C., Shrestha, L., Oser, R., & Salas, E. (1993). Aviation computer games for crew resource management training. *The International Journal of Aviation Psychology*, 3, 143-156.
- Brown, A. H. (1999). Simulated classrooms and artificial students: the potential effects of new technologies on teacher education. *Journal of Research on Computing in Education*, 32, 307-318.
- Coleman, D. S., & Johnston, J. H., (1999). Applications of commercial personal computer games to support naval training requirements: Initial guidelines and recommendations. *Proceedings of the 21st Interservice/Industry Training Systems and Education Conference, Orlando Florida.*
- Dunlap, S., & Tarr, R., (1999). Micro-simulator systems for immersive learning environments. *Proceedings of the 21st Interservice/Industry Training Systems and Education Conference, Orlando Florida.*
- Gonzales, F. E., & Cathcart M. (1995). A procedure for studying strategy development in humans. *Behavior Research Methods, Instruments, & Computers*, 27, 224-228.
- Homan, W. J. (1998). Design of multimedia situational awareness training for pilots. *Educational Media International*, 35, 21-25.
- Huddleston, J., Harris, D., & Tinsworth, A. (1999). Air combat training – the effectiveness of multi-player simulation. *Proceedings of the 21st Interservice/Industry Training Systems and Education Conference, Orlando Florida.*
- Koonce, J. M., Bramble, W. J. (1998). Personal computer-based flight training devices.” *The International Journal of Aviation Psychology*, 8, 277-292.
- Laird, J. E., & van Lent, M. (1999). Human-level AI’s killer application: Interactive computer games. *American Association for Artificial Intelligence Spring Symposium Series: Artificial Intelligence and Interactive Entertainment, Orlando Florida.*
- Morris, C. S. & Tarr, R. W. (March, 2002). Templates for selecting PC based synthetic environments for application to human performance enhancement and training. *Proceedings of the Virtual Reality 2002 Conference, Orlando, Fl.*

- Pillay, H., Brownlee, J., Wilss, L. (1999). Cognition and recreational computer games: Implications for educational technology. *Journal of Research on Computing in Education*, 32, 203-216.
- Randel, J. M., Morris, B. A., Wetzel, C. D., & Whitehill, B. V. (1992). The effectiveness of gaming for educational purposes: A review of recent research. *Simulation & Gaming*, 23, 261-276.
- Ricci, K. E., Salas E., & Cannon-Bowers, J. A., (1996). Do computer-based games facilitate knowledge acquisition and retention? *Military Psychology*, 8, 1996, 295-307.
- Ruben, B. D., (1999). Simulations, games, and experience-based learning: The quest for a new paradigm for teaching and learning. *Simulation & Gaming*, 30, 498-505.
- Salopek, J. J., (1998). Workstation meets playstation. *Training & Development*, 26-35.
- Tallal, P., Miller, S. L., Bedi, G., Byma, G., Wang, X., Nagarajan, S. S., Schreiner, C., Jenkins, W. M., Merzenich, M. M. (1998). Language comprehension in language-learning impaired children improved with acoustically modified speech. In M. E. Hertzig & E. A. Farber (Eds.), *Annual progress in child psychiatry and child development*. Bristol, PA: Brunner/Mazel, Inc.
- Thurman, R.A., & Dunlap, R. D. (1999). Assessing the effectiveness of simulator-based training. *Proceedings of the 21st Interservice/Industry Training Systems and Education Conference*, Orlando Florida.
- Thurman, R. A., & Mattoon, J. S. (1994). Virtual reality: Toward fundamental improvements in simulation-based training. *Educational Technology*, 56-64.

Appendix A

Experience and Demographics Form

Participant Information

1. Age?

2. Gender?

3. Affiliation (check all that apply) UCF _____ IST _____ Military _____

4. Title _____

5. On average, how often have you played the following types of PC or video games (on any console) in the past year?

Shooter

1	2	3	4
Never	1-10 hrs/week	11-20 hrs/week	over 20 hrs/week

Please list any games you have played within this category _____

Strategy

1	2	3	4
Never	1-10 hrs/week	11-20 hrs/week	over 20 hrs/week

Please list any games you have played within this category _____

Simulation

1	2	3	4
Never	1-10 hrs/week	11-20 hrs/week	over 20 hrs/week

Please list any games you have played within this category _____

Real-Time Action

1	2	3	4
Never	1-10 hrs/week	11-20 hrs/week	over 20 hrs/week

Please list any games you have played within this category _____

6. Are you a Psychology major who has taken a Basic Learning course, Cognitive Psychology course or equivalent?

Yes _____ No _____

7. Are you familiar with analysis of military training?

Yes _____ No _____

Appendix B:

Mission Relevant Charts
for Rogue Spear:
Covert Ops

DPQ – RUN 3 Planning phase– Covert Operations Mission CD

	<i>Training Applications</i>			<i>Doctrinal Correctness</i>				
	Rank YES=1 Classroom Enhancement	Train Ups, Initial	Sustaining/Practice Skills	Check off box that applies Not at all	Somewhat	Somewhat	Army Standard/ or YES	5
Multiplayer				1	2	3	4	5
Create game				1	2	3	4	5
Server only control buttons				1	2	3	4	5
- Lock teams				1	2	3	4	5
- Kit Restrictions				1	2	3	4	5
- Eject Player				1	2	3	4	5
- User Password				1	2	3	4	5
- Lock Server				1	2	3	4	5
- Main menu				1	2	3	4	5
Cooperative Team				1	2	3	4	5
Map = (i.e. Kosovo)				1	2	3	4	5
Difficulty level =				1	2	3	4	5
Primary Weapon = M16-A2				1	2	3	4	5
Secondary Weapon = Beretta 92FS 9mm				1	2	3	4	5
Ammunition type = Full Metal Jacket				1	2	3	4	5

DPQ – RUN 3 Planning phase– Covert Operations Mission CD

	<i>Training Applications</i>			<i>Doctrinal Correctness</i>				
	Rank YES=1 Maybe=2 No=3 and comment as much as possible	Train Ups, Initial	Sustaining/Practice Skills	Check off box that applies	Somewhat	Not at all	Army Standard/ or YES	
Equipment = M61 Frag Grenade				1	2	3	4	5
Uniforms = Wood Medium				1	2	3	4	5
Join Game				1	2	3	4	5
Game options				1	2	3	4	5
- Auto targeting				1	2	3	4	5
- blood				1	2	3	4	5
- record mission				1	2	3	4	5
- unlimited practice				1	2	3	4	5
Mouse settings - mouse look, invert, sensitivity				1	2	3	4	5
Predefined interface settings				1	2	3	4	5
- Preferred map zoom				1	2	3	4	5
- Preferred rate of fire				1	2	3	4	5
- Preferred Action display				1	2	3	4	5

DPQ – RUN 3 Planning phase– Covert Operations Mission CD

	Training Applications			Doctrinal Correctness				
	Rank YES=1 Maybe=2 No= 3 and comment as much as possible Classroom Enhancement	Train Ups, Initial	Sustaining/Practice Skills	Check off box that applies Not at all	Somewhat			Army Standard/ or YES
Sounds				1	2	3	4	5
- Master				1	2	3	4	5
- Ambient				1	2	3	4	5
- Gunshot				1	2	3	4	5
- Footstep				1	2	3	4	5
- Radio Chatter				1	2	3	4	5
- Shell sound				1	2	3	4	5
- Action music				1	2	3	4	5
- CD music				1	2	3	4	5
- Use maximal				1	2	3	4	5
Graphics				1	2	3	4	5
- Force software				1	2	3	4	5
- Video resolution				1	2	3	4	5

DPQ – RUN 3 Planning phase– Covert Operations Mission CD

	<i>Training Applications</i>		<i>Doctrinal Correctness</i>				
	Rank YES=1 Classroom Enhancement	Rank No=2 Train Ups, Initial Sustaining/Practice Skills	Check off box that applies	Somewhat	Army Standard/ or YES	5	
- Detail level			1	2	3	4	5
- Use Action Gamma			1	2	3	4	5
- Show tooltips			1	2	3	4	5
Advanced Options			1	2	3	4	5
- Show sky, Fog, Weather Effects			1	2	3	4	5
- LOD skip			1	2	3	4	5
- MIP skip			1	2	3	4	5
- Dynamic lighting			1	2	3	4	5
-Character shadows			1	2	3	4	5
- Projected textures			1	2	3	4	5
- Show weapons after death			1	2	3	4	5
- Bullet holes			1	2	3	4	5
-Texture filtering			1	2	3	4	5
MP Game			1	2	3	4	5
-Name			1	2	3	4	5
-Chan			1	2	3	4	5
- Voice pitch			1	2	3	4	5

DPQ – RUN 3 Planning phase– Covert Operations Mission CD

		<i>Training Applications</i>		<i>Doctrinal Correctness</i>				
Rank YES=1 Maybe=2 No= 3 and comment as much as possible	Classroom Enhancement	Train Ups, Initial	Sustaining/Practice Skills	Check off box that applies				
				Not at all	Somewhat	Army Standard/ or YES		
	-behind firewall			1	2	3	4	5
	-Use arm patch			1	2	3	4	5
	- Connection			1	2	3	4	5
	- Gender			1	2	3	4	5
	- Network address			1	2	3	4	5
	MP Server			1	2	3	4	5
	-Server name			1	2	3	4	5
	-Message of the day			1	2	3	4	5
	- Max # of players			1	2	3	4	5
	- Blue Team size			1	2	3	4	5
	-Gold team size			1	2	3	4	5
	- join port			1	2	3	4	5
	- Info port			1	2	3	4	5
	- Announce port			1	2	3	4	5
	-Use password			1	2	3	4	5
	- Allow arm patches			1	2	3	4	5
	- Force Fog			1	2	3	4	5
	- Force weather effects			1	2	3	4	5

DPQ – RUN 3 Planning phase– Covert Operations Mission CD

Training Applications		Doctrinal Correctness			
Rank YES=1 Maybe=2 No= 3 and comment as much as possible	Train Ups, Initial Skills	Check off box that applies			
Classroom Enhancement	Sustaining/Practice Skills	Not at all	Somewhat	Army Standard/ or YES	
1.) Rate the extent to which the overall planning process allows doctrinal correctness and has value?		1	2	4	5
Comments:					
2.) How comparable is the games planning phase to the 8 step troop leading process?		1	2	3	4
3.) .. Receive and analyze mission? (includes thorough MET-TC analysis, Bn Cdr's intent, CO Cdr's intent and purpose, specified and implied tasks, enemy activities, composition, capabilities, location, formations, attack/defend?)		1	2	3	4
4.) ...Terrain and weather analyzed by OCOKA (obs/FF, Cover/concealment, obstacles, key terrain, ave. approach)?		1	2	3	4
5.) .. Civilian considerations – ROE/ROI, guidelines for dealing with refugees, prisoners, other civilians; working with civilian organizations—govt. agencies, private groups, media; conducting stability operations—peace keeping humanitarian assistance?		1	2	3	4
6.) .. Is IPB played?		1	2	3	4
7.) .. Define Battlefield environment, describe battlefield effects, evaluate the enemy, determine enemy COA.		1	2	3	4
7a.) ..Issue warning order (follow 5 para OPORD format)?		1	2	3	4
7b.) .. Make tentative plan (METT-TC, OCOKA)		1	2	3	4
7c.) .. Initiate movement		1	2	3	4
7d.) ..Conduct recon and coordination		1	2	3	4
7e.) Complete the plan		1	2	3	4
7f.) issue the order		1	2	3	4

DPQ – RUN 3 Planning phase– Covert Operations Mission CD

7g.) supervise and refine			1	2	3	4	5
8.) Is the opportunity to select specific operatives realistic?			1	2	3	4	5
9.) Is it realistic or doctrinally correct to assign primary and secondary weapons, ammunition type, and other "kit" items to squad/fire team members?			1	2	3	4	5
10.) Is preparing the fire and movement plan realistic enough to not inhibit doctrinal correctness?			1	2	3	4	5

DPQ – RUN 3 Planning phase– Covert Operations Mission CD

Overall Comments: A 9-man infantry squad would be used to clear a 5-room building. A platoon would be used to clear 2-3 buildings (FM 90-10-1, Jul 2000). The PC game used a 4-man team (fire team size) and the demo mission had them clearing a series of buildings, which is not realistic.

There must be a clear order [Rules of Engagement (ROE)/Rules of Interaction (ROI)] regarding hostages. It is normal to use “weapons tight” or ROE -restrictive (return fire only) when encounters with hostages are expected.

An introduction to the mission must include who, what, where, when, why. Personnel requirements are still made for real tests of developmental equipment or tactics. Due to undermanned units, it's difficult to get a full squad for a test. No squad integrity can be sustained if nine soldiers from different squads/platoons, etc., are used.

The focus for a particular scenario snippet from the game must be narrow and clearly defined. Furthermore, any portions of the game that could be used to rehearse something specific to a training requirement would be a plus.

Should always "pie the corner," (method of lining up on opposite sides of an entrance so that all points in the room to be entered can be seen without any soldier being in the line of fire)

Don't “flag” weapon (this refers to weapon being held out and away from the body of the soldier).

Once in a room the weapon stays up. (During game play the weapon drops when not in use)

There is a need to capture (hear) dialogue between squad members.

Need an AAR procedure to replay good and poorly executed tactics. Turn off the round count. Capability to change magazines is important and should be played without benefit of a round counter.

Drop to one knee when changing magazines so others will know to cover your area. (Soldiers should also take a knee when not maneuvering).

Keep the game user friendly and make it simple to assess leadership.

Regarding the kit selection, a full metal jacket (FMJ) is always used because a hollow point is against Geneva Convention.

It is possible to use the 4-man stack for role-playing. Soldiers use independent thought for each room - one room is a garage, one a living room, one a warehouse, etc. Soldiers won't have a map of the building (like used in this study) at squad level.

Tactical movement in the game is relatively realistic if it is made clear that participants have an additional support team or platoon in an overwatch capacity. A 4-man fire team cannot support itself. Once a team clears an area some element must remain in place or another must relieve it in place.

The games could be used for tactical movement, tactical scenario, and room clearing. It is OK to use notional support elements, but must address that in lead-in. Marry up collective tasks from Automated Systems Approach to Training (ASAT) database with specific aspects of the game. AAR should marry audio with stealth view.

Appendix C:

Infantry Evaluation Detailed Results

Appendix C- Infantry Evaluation Detailed Results

Game options, capabilities & events addressed	Scores represent (1) = no doctrinal value to (5) = Yes, army standard. With noted issues, comments, and solutions
Mission briefing	(5) Has utility to use as is. (3) Break it down to a team leader level
Mission intel categories / subjects	(1) Too game-ish (5) Good If tailored to a TM or squad mission may have utility Make less game like
Planning phase	(1) Not realistic Make less game like If made like weapons selection adding a menu and secondary systems (i.e., rafeal or bunker buster, slope changes, AF-8 etc.)
Roster screen	(1) Not necessary (1) Delete, it is not realistic
Kit selection	(5) Has Frags/Flashbang m16 vs m4 (5) (4) Make less game like Like mission tailoring capability need to expand listing. Less focus on exotic offer more changes
Primary weapons	(5) Good round count forces player to change mags (2) not much choice in TU&E units (5) Make less game like
Secondary weapons	(1) Privates don't carry secondary weapons (4) Some utility Constrain any use of secondary weapons Less focus on expotic systems more on various systems to support mission
Ammunition type	(1) Not realistic (1) Turn off option
Equipment	(1) Not realistic (5) Turn off option More choices of equipment to support mission

Game options, capabilities & events addressed	Scores represent (1) = no doctrinal value to (5) = Yes, army standard: With noted issues, comments, and solutions
Uniforms	(1) Never a choice (4) Turn off option
Team selection Blue, red, green, and gold	(1) Not necessary (2) Need only good and bad
Mission plan	(1) Possible but not shown here (5) Supports good planning (i.e., room clearing) (5) Excellent rehearsal tool Too many buildings a platoon can clear 2-3.
Orders	(1) Not realistic, too game like (2)
Plotting movement - map controls	(1) Not realistic, too game like (2)
Rules of engagement	(1) too game like (1)
Speed	(1) will only be used as demo (1)
Special actions	(1) Not realistic (1)
Ability to exercise	(5) Valuable if done to doctrine (5) Use of map is superb
Ability to execute Batallian Commanders intent	(5) Valuable if it is a realistic intent (1) not appropriate at squad level
Specified and applied missions	(5) if they are covered in the AAR (1) Need AAR
8 step troop leading process demonstrable? ability to apply or practice	(1) (5) has Capability (1) (5) make less game like Add a laminated troop leading process check list to the job aides

Game options, capabilities & events addressed	Scores represent (1) = no doctrinal value to (5) = Yes, army standard. With noted issues, comments, and solutions
Kinds of logistics potentially demonstrated	(1) (2) Needs to be kept short with AAR's to instill learning
Option (auto targeting)	(1) Needs to replicate PAQ 4c, PEQ2a, TWS MRD, PVS-14, CCO (1) If could be made to replicate CCO Disengage, turn it off
Option: blood	(1) Not realistic (3) Good for psychological impact Could not be made to be realistic
Option: recording mission	(5) (5) Only in observer view/stealth Needs to be added into collective training Add audio
Interface: preferred map zoom	(5) Very good to demo L.W. capabilities (5) map zoom only Enlarge for AAR purposes. Make sure player cant see that you are recording
Interface: Preferred rate of fire	(1) not realistic, menu selected (5) good tool Needs to be kept adjustable during mission
Interface: preferred action display	(5) Good support first person view (5) keep variable display. Good for AAR purposes
Sounds: gunshot	(1) not loud enough (5) KEEP will never be loud enough
Sounds: footstep	(1) not realistic (5) KEEP
Sounds radio chatter	(1) not realistic (1) meaningless chatter is useless
Sounds: shell sound	(1) not realistic (3) marginal value

Game options, capabilities & events addressed	Scores represent (1) = no doctrinal value to (5) = Yes, army standard. With noted issues, comments, and solutions
Sounds action music	(1) not realistic (1) Delete
Graphics: resolution & detail	(1) (1) N/A
Graphics: Tooltips	(1) N/A
Sky, fog, lightening, weather	(2) not realistic (5) rain and fog are ok and needed for limited visibility training Lightening is a waste of time
Shadows: character, buildings, and projected textures	(4) Good, can shoot through doors and windows, however, walls can't be shot through (4) Need to be able to shoot through walls Would be nice to be able to adjust time of day as opposed to game dictating
Number of players, multiplayer capabilities and teaming abilities	(4) Can display the necessary 4 man stack. (5) can use work arounds to replicate squad and X number of OPFOR Need to be able to make personnel varied so that one can tell others to do something
Targeting reticule and ridicule modifiers	(1) movement (1) stance change (1) fatigue level (1) health level (1) firing (4) taking hits, good because can make player limp (5) flashbangs, realistic (5) delete fatigue and health variables
Action bar	(5) map window, great L.W. display (1) weapons display (1) active team display (1) all teams display (1) Delete all
Control (movement, weapons, doors)	(5) Good

Game options, capabilities & events addressed	Scores represent (1) = no doctrinal value to (5) = Yes, army standard. With noted issues, comments, and solutions
Replay AAR	(5) Great capability (4) Must have someone to conduct the AAR
Cover and concealment	(3) Could possibly be done if solid furniture were provided. Not able to assume prone position (5) the multi-floor diagrams are a plus for rehearsals Need furniture and ability to assume prone position
Team security - Flank, assume defensive postures, cover / counter attack routes	(4) supports it and can be done (5)
Mutual support	(5) Can be done in the game (5)
Fields of fire	(4) Can be done in game if provided proper instruction (5)
Leadership skills	(4) Could be done in the game, great for leadership on contributing kit selection (5) Needs to be slower than shown
Door breaching	(4) Could be done and teach blast radius etc. (5)
Assault procedures	(5) Could be done in game need stacking capabilities
Covering fire	(5) could be taught in game if the game were slower. Game moved too fast Slow the game down
Covered routes	(5) Could be done with ground view of street, alley etc.
Room clearing procedures	(5) Could be taught with overhead view, then practicing in the game Need a way to grade the game after played
Communication	Supports good interaction and planning if inter team sound systems employed Need outside noise distraction and team radios
Re-supply and re-arm	(5) magazine changes could be taught here Round count is a major plus. Changing magazines is very realistic.

Game options, capabilities & events addressed	Scores represent (1) = no doctrinal value to (5) = Yes, army standard. With noted issues, comments, and solutions
AAR or mission replay	(1) not a function of game Game does not allow for replay in multi-player mode Need overhead view similar to the floor diagram in mission rehearsal (4) if accommodations made so to display it User must record mission using alternative output replay devices (i.e. VCR) Need to record audio in alternative fashion as well
Game fidelity	(1) grenade throwing not realistic functioning
Psychological issues	(1) game too difficult, promotes negative learning can not simulate blood and death players can eventually win missions only by memorizing what the enemy AI will do
Weapons orientation	(1) could be taught but cannot be controlled with a pc (1) grenades/flashbangs cannot train for airburst
Overall game potential to allow doctrinally correct procedures	(4) has potential but not as demonstrated for this event practice for small aspects (not whole town) but very specific, narrow and defined with narrow scope and narrow OPFOR
Capability for good classroom enhancement (i.e. demo's)	(5) Definitely has use: demonstration on large screen with all pro's and con's pointed out Potential uses: Room clearing can build into scenarios covering other troops. Movement program has flaws and plusses. Tactical scenario training
Capabilities for initial train ups	Has some potential for initial train ups RC movement need a better demonstration
Skills practice and sustaining skills	(2) Once the basics are learned, a game is not the place to sustain proficiency RC Interoperation, independent thought applied to tactic To get roles down Use map views. Good here

Appendix D:

Armor Evaluation Detailed Results

Appendix G: Armor results

ARMOR responses and potential solutions

- Must determine what we are trying to teach - Gunnery, command and control, individual tasks, collective tasks?
- SB plays a four tank platoon (M1A1s) with options for a TC and gunner in the same tank, or TCs, or gunners in two different tanks. The loader is not played and the TC performs driver functions which is not doctrinally correct.
- A determination should be made on whether the game is better suited as a teaching aid, or trainer, for tank gunnery or combined arms command and control.
- The game does not allow the TC to override the gunner in target engagements - considered a serious drawback.
- Better to use Mission Training Plans (MTPs) that provide a complete set of individual and crew tasks rather than the platoon reaction exercises which are more general in nature.
- The game must allow the tanks to fire on the move. Tanks under computer control stop before they engage a target.
- Players must tell the game to allow tanks to fire while on the move. This is a serious problem for training purposes.
- Users are not permitted to view and modify algorithms for OPFOR. In order to provide realism the operators (trainers) must be able to view and modify the algorithms used for both OPFOR and BLUFOR. This would permit target engagements as soon as tanks are within line-of-sight.
- C2 is difficult to incorporate into the game due to the fact that the Platoon Leader, as a TC, is basically the tank driver in the game.
- While the TC does instruct the driver, the Plt Ldr must also command his tank and coordinate the activities of the other three tanks in his platoon.
- The players mentioned that they had never defeated the OPFOR in the game. That in itself is negative training.

- A better use of the game would be to set up a gunnery lane - a firing range whereby one tank engages different types of targets – tanks, trucks, troops in the open, etc.
- An approach similar to Tank Table X, if still in use, would be beneficial.
- The game would be a precursor to training in a UCOFT or TWGSS and would begin by engaging stationary targets from the halt. The emphasis would be on target acquisition and the coordination between TC and gunner – proper commands, proper procedures – target tracking, ammunition selection, etc to ensure a successful engagement.
- Difficulty could be added as proficiency increased – e.g. firing on the move against moving targets, and timed exercises whereby targets engage your tank as line-of-sight is established.
- During the play of the game there was little or no dialogue between TC and gunner players. It was played as two gamers trying to engage as many targets as possible rather than following proper target engagement procedures which is not enforcing doctrine.
- The computer-controlled tanks automatically considers dismounted soldiers a greater threat than opposing tanks and tend to slew off tanks and on to dismounted soldiers for initial engagements which is in opposition to military tactic and doctrine.
- The game gives no credit for dismounted soldier engagements or kills.
- There was a lack of team integration. Tank gunnery is a team effort and player coordination must be a part of the game. (Flying a plane, on the other hand, is a one-man skill. Realistic flight games such as FlightSim could provide individual proficiency).
- The focus of the gaming effort should be on determining what “tasks” could best be trained through PC games. Cues and responses for specific tasks can be determined, then a determination made about the game’s capability to provide the required inputs. They mentioned the TPSC codes used with the CCTT studies.

- A method is needed to list, by task, what the developer has to provide to support training.
- An alternative is to use Tac Ops, a PC game recently introduced at USAARMS for armor branch advanced course students. The game is apparently somewhat “primitive” but has utility for armor company grade officers (LTs and CPTs).

Appendix E:

Sample Game Maps - Steel Beasts™

Steel Beasts

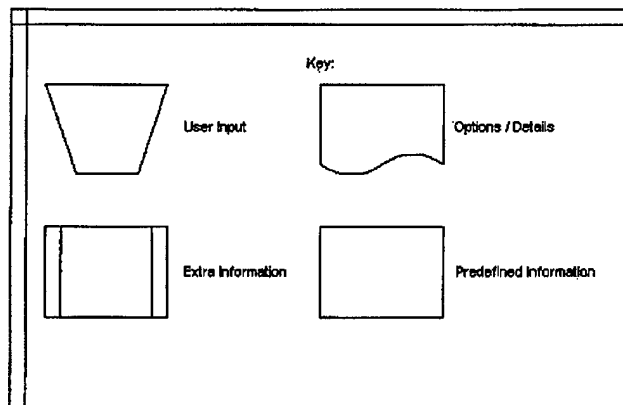

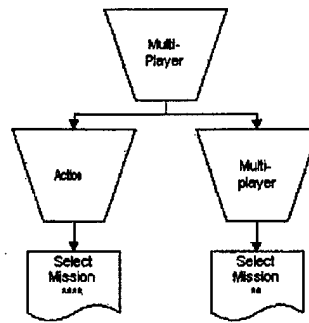
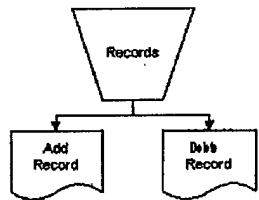
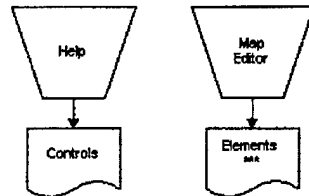
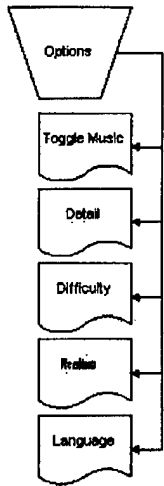
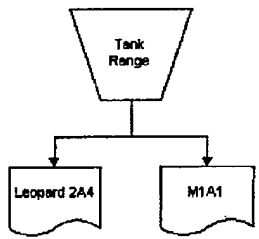
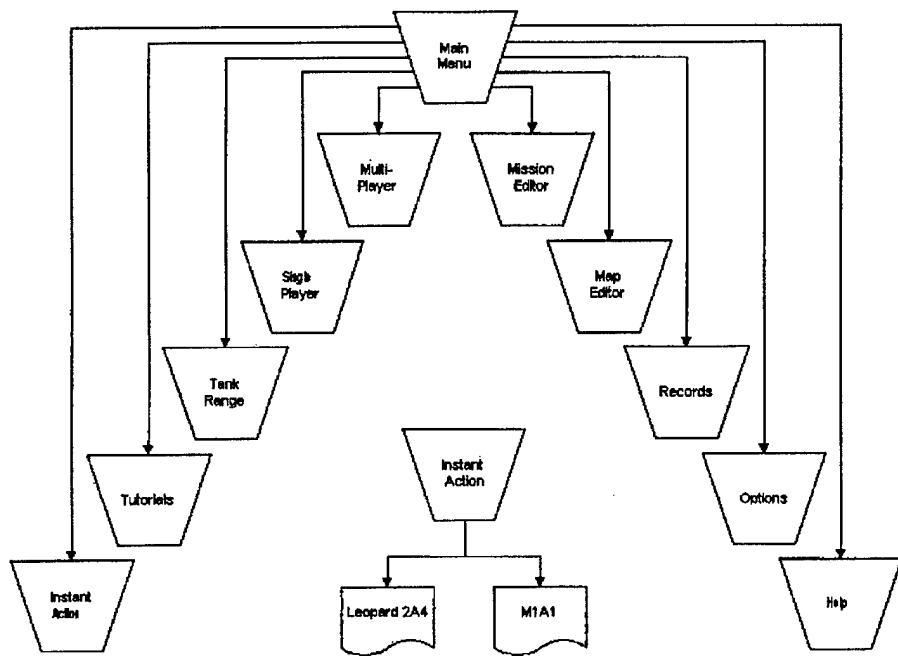

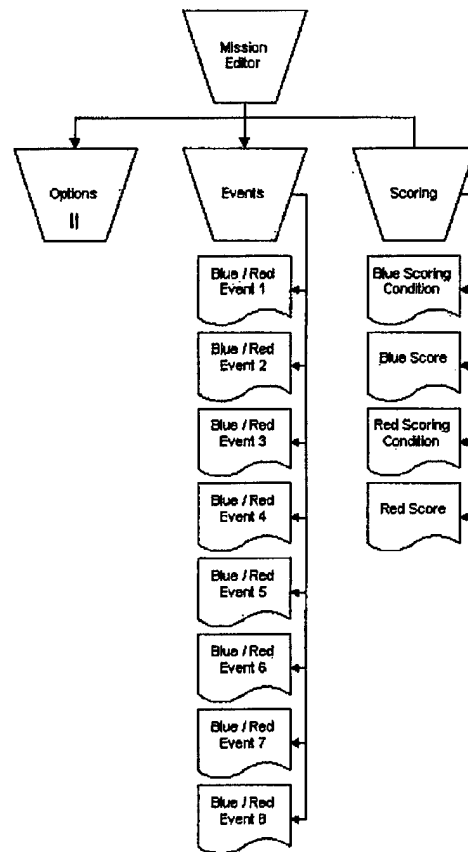
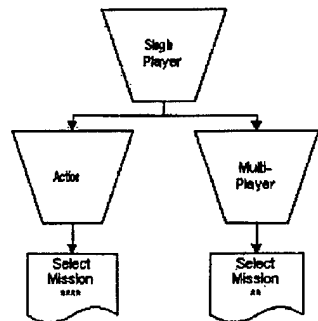

- ^{**} Select Multiplexer Mission
- Austin Recon
 - Recon town of Austin
 - Convoy Escort (MP)
 - Escort hummers across an island
 - Deliberate Assault 01 MP
 - Seize objectives Viking & Mongol
 - Deliberate Assault 01 MP CO-OP
 - Seize objectives Viking & Mongol
 - Deliberate Assault 01 MP Small
 - Seize objectives Viking & Mongol
 - Deliberate Assault 02 MP
 - Seize town at objective Jupiter
 - Seize crossroads and bridges at objective Mars
 - Deliberate Assault 02 MP CO-OP
 - Seize town at objective Jupiter
 - Seize crossroads and bridges at objective Mars
 - Leo 2A4 vs M1A1 MP
 - Defend with Leopards against M1 assault
 - Leo 2A4 vs M1A1 MP 2
 - Defend with Leopards against M1 assault
 - Leo 2A4 vs M1A1 MP 3
 - Defend with Leopards against M1 assault
 - M1 v Leo2 2on2 Death Match
 - M1 v Leo2 2on2 SmI Death Match
 - M1 v Leo2 2on2 With IFV's
 - M1 v Leo2 4on4 Death Match
 - M1 v Leo2 4on4 With IFV's
 - M1 v Leo2 6on6 Death Match
 - M1 v Leo2 6on6 With IFV's
 - M1 v Leo2 8on8 Death Match
 - M1 v Leo2 8on8 With IFV's
 - M1 v Leo2 Death Match
 - Meeting in The River Valley MP
 - Meeting in The River Valley pt.2 MP
 - MP Leo2s Assault M1s
 - Defend with M1s against Leopard assault
 - MP M1s Assault Leo2s
 - Defend with Leopards against M1 assault
 - MP OPFOR Assaults Leo2s
 - Defend with Leopards against Soviet assault
 - MP OPFOR Assaults M1s
 - Defend with M1s against Soviet assault
 - MTC in The Desert 01 MP
 - Seize objectives Ramsis & Isis
 - MTC in The Desert 01 MP Small
 - Seize objectives Ramsis & Isis
 - Tank Table XII MP
 - Patrol leader qualification course

- ^{***} Elements:
- Dirt
 - Grass
 - Sand
 - Water
 - Bog
 - Woods
 - Trees
 - Bush
 - Road
 - Ditch
 - Barr1 (object)
 - Barr2 (object)

^{*} Support available in none, low, medium, high, and top

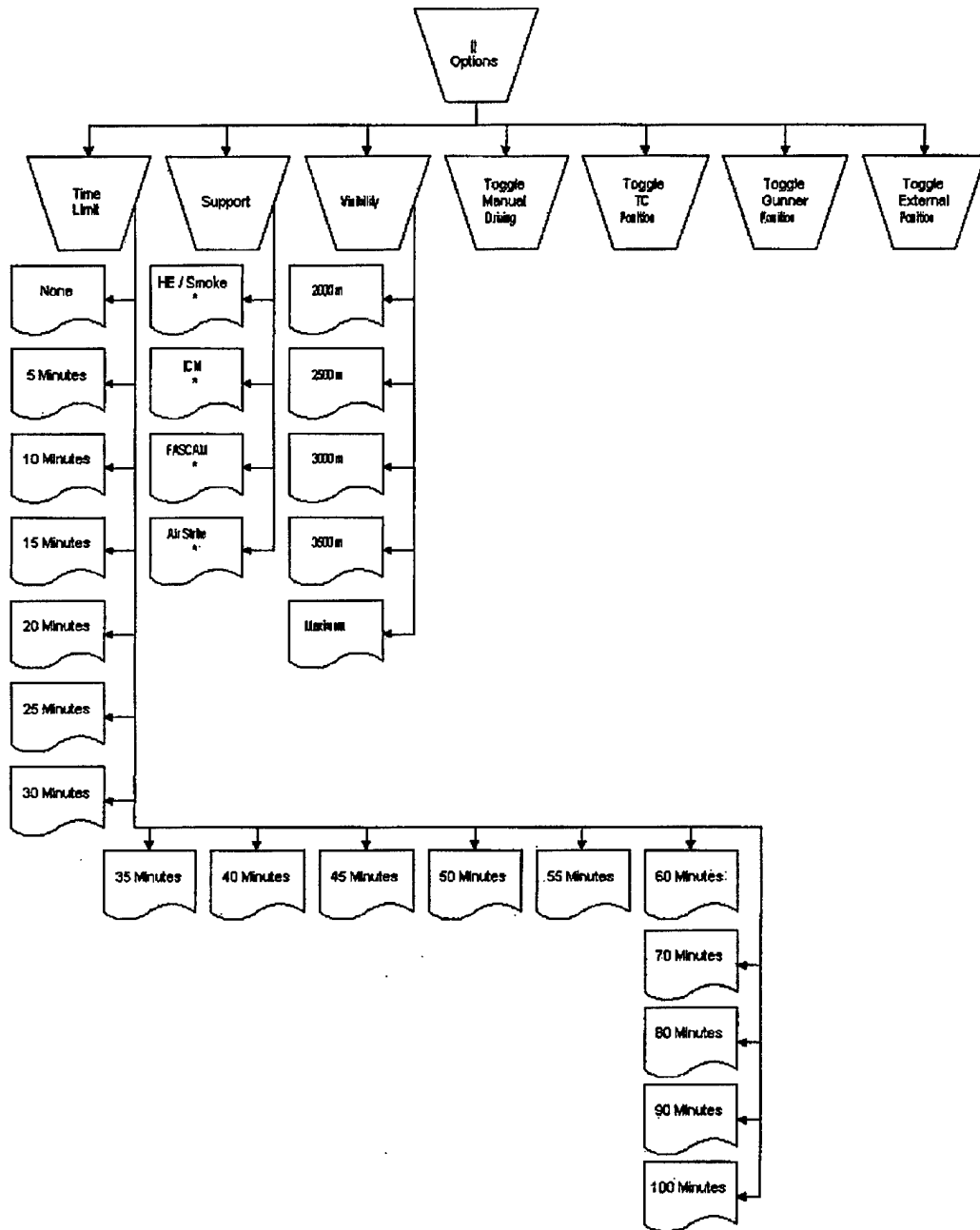

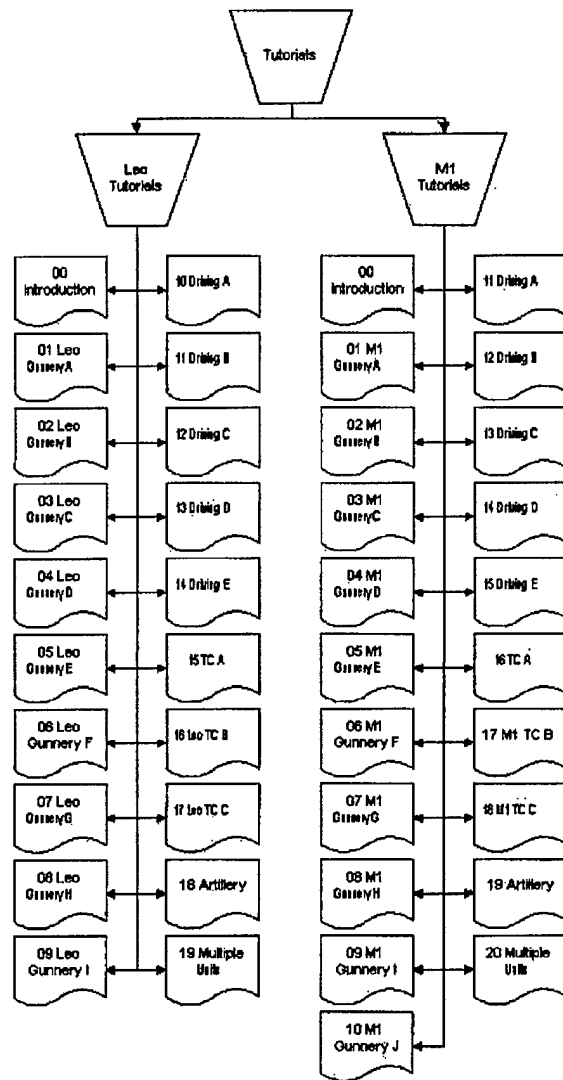

**** Select Action Mission:
 A Village Called Netreba
 Defend village from attack

Ambush
 Defeat the enemy recon units

Are They Attacking Here
 Correctly determine the nature and intent of the enemy force
 Defeat enemy forces

B_Leo vs M1
 Defend against M1 assault with Leopard

b_recon
 Reconnoiter the vicinity of a bridge

Battle In Kuwait
 Begin ground attack against Iraqi forces

Battle Of The Wese Valley
 Defeat the enemy's recon forces & halt southern advancement

Breedendostel
 Explore territory

Bridgehead
 Retake a captured bridge

Canadian_Frost
 Defend territory

Calvary To The Rescue
 Guard A1-6 Infantry

Combat Trains
 Destroy all enemy forces

Company Convoy
 Friendly forces must reach TAA VAN HALEN and secure it

Deliberate Assault 01
 Seize objectives Viking and Mongol

Deliberate Assault 02
 Seize town at objective Jupiter
 Seize bridges and crossroads at objective Mars

Deliberate Defense 01
 Defend BP1 & BP2

Demo_Attack
 Take objective before reinforcements can arrive

Demo_Attack_Leo
 Attack the enemy company and cut off reinforcements ^

Desert Attack
 Break through the Motor Rifle Division line

Desert Delay 3
 Delay advancing troops

Escape From Gozen
 Escape from behind enemy lines

FH01 First Contact
 take out the T-80s

FH02 First Attack
 Capture OBJ-1 & OBJ-3

FH03 Flank Guard
 Defend bridge

Fort Apache
 Rescue surviving units of a US-led armored patrol

Gen_Recon1
 Reconnoiter enemy positions of two bridges

Hasty Defense 01
 Defend against advancing forces

Heavy Reconnaissance
 Reconnoiter area in preparation for battle

Instant Action - Ambush
 Two M1's ambush a company of Optr tanks and BMPs

Instant Action - Road March
 Cope with being ambushed

Instant Action - Urban Assault
 Blue is launching an attack on a small town and Red is defending

JRS - Korean Nightmare 2
 Hold the line at Seoul

Korean Nightmare
 Defend against advancing forces

March
 Assist a company in spearheading your battalion's march

Meeting 2
 Intercept enemy tanks

Movement To Contact 01
 Attack enemy units defending objective Atlas

Moving_Ambush
 Practice executing a moving ambush

Operation Dust Devil
 End enemy aggression at the Iraq/Kuwait border

Operation Slave
 Actively stop raids before forces reach Namibian territory

Stormin' The Desert
 Open the Desert Storm

Sucker Punch In Kuwait
 Attack Iraqi forces under veil of dust storm

Tank Table VII
 Test engagement of moving and stationary targets

Tank Table VII 3
 Test engagement of moving and stationary targets

Tank Table VII - 4
 Test engagement of moving and stationary targets

Tank Table VI
 Platoon leader qualification course

Tanks
 Assault on tanks

The Battle For Windy River
 Secure a crucial river crossing

The Siege Of Gozen
 Take Gozen

The Warts Objective
 Reconnoiter enemy forces
 Plan and conduct an attack on enemy forces

Woods_Have_Eyes
 Slow enemy advancements until reinforcements arrive

^ Translated from German...

Legend

