

REPORT DOCUMENTATION PAGEForm Approved
OMB No. 074-0188

Public reporting burden for this collection of information is estimated to average 1 hour per response, including the time for reviewing instructions, searching existing data sources, gathering and maintaining the data needed, and completing and reviewing this collection of information. Send comments regarding this burden estimate or any other aspect of this collection of information, including suggestions for reducing this burden to Washington Headquarters Services, Directorate for Information Operations and Reports, 1215 Jefferson Davis Highway, Suite 1204, Arlington, VA 22202-4302, and to the Office of Management and Budget, Paperwork Reduction Project (0704-0188), Washington, DC 20503

1. AGENCY USE ONLY (Leave blank)		2. REPORT DATE September 2001	3. REPORT TYPE AND DATES COVERED Final Report	
4. TITLE AND SUBTITLE Novel Nonporous Fouling-Resistant Composite Nanofiltration Membrane and Membrane Separation Systems for Wastewater Treatment Important for CPSON5/PPSON1: Minimization of Oily and Non-Oily Wastewater			5. FUNDING NUMBERS N/A	
6. AUTHOR(S) Benny D. Freeman				
7. PERFORMING ORGANIZATION NAME(S) AND ADDRESS(ES) NC State University Department of Chemical Engineering Raleigh, NC			8. PERFORMING ORGANIZATION REPORT NUMBER N/A	
9. SPONSORING / MONITORING AGENCY NAME(S) AND ADDRESS(ES) SERDP 901 North Stuart St. Suite 303 Arlington, VA 22203			10. SPONSORING / MONITORING AGENCY REPORT NUMBER N/A	
11. SUPPLEMENTARY NOTES No copyright is asserted in the United States under Title 17, U.S. code. The U.S. Government has a royalty-free license to exercise all rights under the copyright claimed herein for Government purposes. All other rights are reserved by the copyright owner.				
12a. DISTRIBUTION / AVAILABILITY STATEMENT Approved for public release: distribution is unlimited.			12b. DISTRIBUTION CODE A	
13. ABSTRACT (Maximum 200 Words) Navy ships generate large volumes of wastewater (about 20-70 gal/day of water per crew member) which, to meet new regulations, require treatment prior to overboard discharge. In the past, all wastewater was simply discharged overboard. More recently, regulating bodies such as MARPOL, the EPA, the U.S. Coast Guard, and some states have enacted restrictions on the location and extent of such discharges. Polymeric nanofiltration/ultrafiltration membranes able to produce dischargeable water have already been considered for shipboard wastewater treatment. The problem with this approach is fouling of the membrane by a layer of colloidal and particulate material that forms a secondary barrier to flow through the membrane. To overcome the problems of membrane fouling and the need for periodic cleaning, NC State University (NCSU) and Membrane Technology and Research, Inc. (MTR) have developed a new type of composite membrane in which a thin, highly water-permeable polymer coating layer is used to completely eliminate internal membrane fouling and significantly reduce the effect of surface fouling.				
14. SUBJECT TERMS SERDP, SERDP collection, nanofiltration, wastewater, membrane			15. NUMBER OF PAGES	
			16. PRICE CODE N/A	
17. SECURITY CLASSIFICATION OF REPORT unclass	18. SECURITY CLASSIFICATION OF THIS PAGE unclass	19. SECURITY CLASSIFICATION OF ABSTRACT unclass	20. LIMITATION OF ABSTRACT UL	

NSN 7540-01-280-5500

Standard Form 298 (Rev. 2-89)
Prescribed by ANSI Std. Z39-18
298-102

103 236

**Novel Nonporous Fouling-Resistant Composite Nanofiltration
Membrane and Membrane Separation Systems
for Wastewater Treatment Important for CPSON5/PPSON1:
Minimization of Oily and Non-Oily Wastewater**

Final Report
Contract Number CP/1108
Contract Period: June 4, 1998 to June 4, 2001

submitted to

Strategic Environmental Research and Development Program

by

Professor Benny D. Freeman
NC State University
Department of Chemical Engineering
Raleigh, NC 27695-7905

September, 2001

20030103 236

DISTRIBUTION STATEMENT A
Approved for Public Release
Distribution Unlimited

EXECUTIVE SUMMARY

Navy ships generate large volumes of wastewater (about 20-70 gal/day of water per crew member) which, to meet new regulations, require treatment prior to overboard discharge. In the past, all wastewater was simply discharged overboard. More recently, regulating bodies such as MARPOL, the EPA, the U.S. Coast Guard, and some states have enacted restrictions on the location and extent of such discharges.

Polymeric nanofiltration/ultrafiltration membranes able to produce dischargeable water have already been considered for shipboard wastewater treatment. The problem with this approach is fouling of the membrane by a layer of colloidal and particulate material that forms a secondary barrier to flow through the membrane. To overcome the problems of membrane fouling and the need for periodic cleaning, NC State University (NCSU) and Membrane Technology and Research, Inc. (MTR) have developed a new type of composite membrane in which a thin, highly water-permeable polymer coating layer is used to completely eliminate internal membrane fouling and significantly reduce the effect of surface fouling.

In this three-year research project, the focus of the first year was selection and optimization of the membrane materials. In the second year, membranes were prepared with industrial-scale equipment, a module test system was built, and the first bench-scale membrane modules were made. In the third year, the optimum membrane and module configuration was selected and several long-term runs were performed with solutions chosen to model shipboard wastewater. Composite nanofiltration membranes prepared with laboratory- and industrial-scale membrane manufacturing equipment had water fluxes in the range 150 to 200 L/m²·h at 150 psig. Their molecular weight cutoff was between 5,000 and 10,000 dalton. Bench-scale membrane modules were very resistant to fouling with oil/water emulsions containing up to 5% oil in tests lasting up to 80 days and in tests with graywater surrogate mixtures. Stable fluxes of 50 L/m²·h were obtained with oil emulsions and 20-40 L/m²·h with graywater surrogate mixtures. The permeate from these membranes would meet the new discharge regulation set by the MARPOL agreement.

The membrane modules can be cleaned satisfactorily by a clean water rinse cycle and even better by a cleaning technique developed during the project. The technique seems particularly suitable for shipboard oily and non-oily wastewater treatment systems. The technology is now ready for evaluation at the pilot-scale using a 1,000- to 5,000-gal/day unit operating pier-side to treat Navy ship wastewaters.

Table of Contents

SUMMARY	i
1. PROJECT BACKGROUND, OBJECTIVE, AND TECHNICAL APPROACH	1
2. RESULTS AND DISCUSSION	5
2.1 Membrane Preparation	5
2.2 Composite Membrane Characterization	6
2.3 Module Preparation	7
2.4 Module Testing	9
3. EXPERIMENTAL RESULTS AND DISCUSSION	10
3.1 Membrane Tests	10
3.1.1 Membrane Characterization	10
3.1.2 Membrane Chemical Stability Evaluation	13
3.2 Module Tests	15
3.2.1 Test Solutions	15
3.2.2 Initial Flux and Rejection Tests	16
3.2.3 Effect of Feed Spacers	19
3.2.4 Long-Term Tests	23
3.3 Module Cleaning	24
4. CONCLUSIONS, TRANSITION PLAN, AND RECOMMENDATIONS	27

List of Figures

Figure 1.	Schematic representation of fouling on an ultrafiltration membrane.	2
Figure 2.	Ultrafiltration flux as a function of time for a latex emulsion.	3
Figure 3.	Schematic drawing of composite nanofiltration/ultrafiltration membrane.	4
Figure 4.	Repeat unit of polyamide (PA)-polyether (PE) block copolymers.	4
Figure 5.	Project schedule.	5
Figure 6.	Schematic diagram of support membrane casting machine.	5
Figure 7.	Schematic diagram of thin-film coating apparatus.	6
Figure 8.	Schematic diagram of the test apparatus for measuring gas and vapor permeation through thin composite membranes	6
Figure 9.	Simplified flow schematic of cross-flow test system	7
Figure 10.	Schematic diagram of the module-winding operation.	7
Figure 11.	Schematic of spiral-wound module.	8
Figure 12.	Flow schematic and photograph of one of the module test systems.	9
Figure 13.	Water flux of Pebax composite membranes on a PVDF support as a function of the number of selective layer coatings with a 1% Pebax solution in butanol.. . . .	12
Figure 14.	Feed flow rate of a Pebax 1074 module (#1510) as a function of pressure drop across the module.. . . .	17
Figure 15.	Water flux of a Pebax 1074 module (#1510) as a function of average feed pressure.	17
Figure 16.	Pressure-normalized water flux of a Pebax 1074 module (#1510) as a function of average feed pressure.	18
Figure 17.	Feed flow rate as a function of average feed pressure for Pebax 1074 modules with various feed spacers.. . . .	19
Figure 18.	Water flux of Pebax 1074 modules having feed spacers (a) ROF025, (b) ROF030 and (c) MWN048 as a function of feed pressure.. . . .	21
Figure 19.	Water fluxes as a function of operating time for Pebax 1074/PVDF modules: (a) 1616 with an ROF025 spacer, (b) 1617 with an ROF030 spacer, and (c) 1619 with an MWN048 spacer.. . . .	22
Figure 20.	Change in flux over time for an uncoated microporous polyvinylidene fluoride (PVDF) ultrafiltration membrane module and the same membrane coated with a 0.5-1.0 micron polyether-polyamide layer (Pebax 1074).	23
Figure 21.	Water fluxes of uncoated and Pebax 4011-coated tubular Zenon membranes as a function of permeation time.	24
Figure 22.	Backflushing, flow-reversal technique for cleaning membrane modules by closing the permeate port.	25
Figure 23.	Backflushing, flow-reversal cleaning of a bench-scale nanofiltration Pebax 4011 composite membrane spiral-wound module.	27

List of Tables

Table 1. Gas Permeation Properties of Microporous Support Membranes [polysulfone, polyetherimide, and poly(vinylidene fluoride)] and Pebax 4011 and 1074 Thin-Film Composite Membranes.	11
Table 2. Solute Rejections of Pebax 1074/PVDF Composite Membrane.	12
Table 3. Solute Rejections of 2% Pebax 4011/PVDF Composite Membrane.	13
Table 4. Effect of pH and Sodium Hypochlorite Concentration on the Gas Permeation Properties of Pebax 1074/PVDF Composite Membrane Soaked for One Week in the Test Solution.	14
Table 5. Water Fluxes and Solute Rejections of Pebax 1074/PVDF Composite Membranes Soaked in Water, in Buffer Solutions of a Range of pHs, and in Sodium Hypochlorite Solutions for One Week.	15
Table 6. Model Wastewater Composition.	16
Table 7. Water Fluxes and Solute Rejections of the Pebax 1074/PVDF Composite Membrane Module.	18
Table 8. Candidate Feed Spacer Properties.	19

1. PROJECT BACKGROUND, OBJECTIVE, AND TECHNICAL APPROACH

Navy ships generate large volumes of wastewater (about 20-70 gal/day of water per crew member) which, to meet new regulations, require treatment prior to overboard discharge. The wastewater is generally segregated into three streams according to the source. Blackwater is the sanitary water from commodes, urinals, and garbage grinders. Graywater includes galley water from sinks and kettles; turbid water from showers and laundry; and drainage water from air conditioners, drinking fountains, and interior deck drains. An additional wastewater is the secondary oily wastewater from parallel-plate separation of oil/water mixtures that accumulate in the bilge of a ship.

In the past, all wastewater was simply discharged overboard. More recently, regulating bodies such as MARPOL, the EPA, the U.S. Coast Guard, and some states have enacted restrictions on the location and extent of such discharges. These restrictions and the logistics of holding onboard and transferring to shore barges large volumes of wastewater have generated considerable interest in developing onboard wastewater treatment technology, called Marine Sanitation Devices. All new Navy ships will be fitted with these devices to minimize the environmental impact of shipboard wastewater.

The Carderock Division, Naval Surface Warfare Center, and its subcontractors have been working on this problem for some time. So far the most promising approach has been to use membrane bioreactors of various designs, which combine biological treatment with membrane separation. The goal of this project, funded by the Strategic Environmental Research and Development Program (SERDP), was to develop non-fouling composite nanofiltration membranes. In some cases such membranes would replace membrane bioreactors; in other cases the membranes would be combined with membrane bioreactors to improve reactor performance.

Polymeric nanofiltration/ultrafiltration membranes able to produce dischargeable water have already been considered for shipboard wastewater treatment. The problem with this approach is fouling of the membrane by a layer of colloidal and particulate material that forms a secondary barrier to flow through the membrane as shown in Figure 1. Surface fouling can be removed by periodic cleaning, but internal fouling caused by deposition of solid material in the interior of the membrane is generally irreversible.

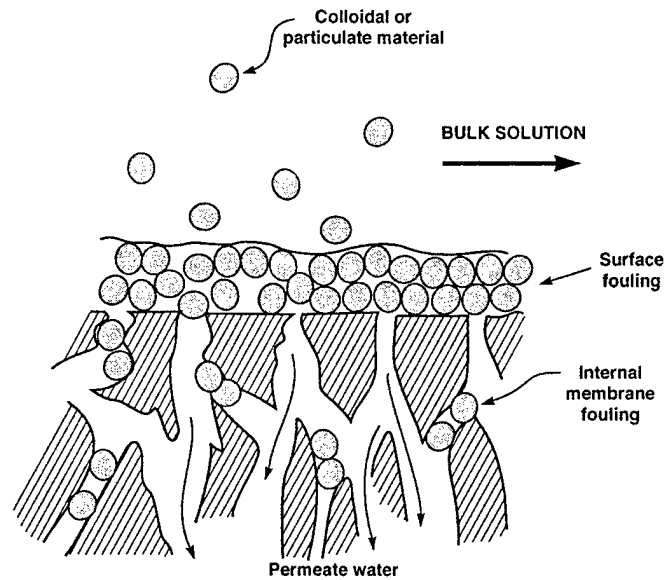

- 1 Schematic representation of fouling on an ultrafiltration membrane. *Surface fouling* is the deposition of solid material on the membrane that consolidates over time. Surface fouling is generally reversible. *Internal fouling* is caused by penetration of solid material into the membrane, which results in plugging of the pores. Internal membrane fouling is generally irreversible.

A typical plot illustrating the decrease in membrane flux that can result from membrane fouling is shown in Figure 2. The pure water flux of these membranes is approximately 50 gal/min but on contact with an aqueous emulsion, the flux immediately falls to about 10-12 gal/min. This first drop in flux is due to the formation of a gel layer on the membrane surface. Thereafter, the flux declines steadily over a two-week period. This second drop in flux is caused by densification of the gel layer under the pressure of the system. In this particular example the densified gel layer could be removed by periodic chemical cleaning of the membrane, which restored the flux to that of a new membrane. However, regular chemical cleaning as shown in Figure 2 is not suitable for a shipboard environment because of the quantity of chemicals and high maintenance involved.

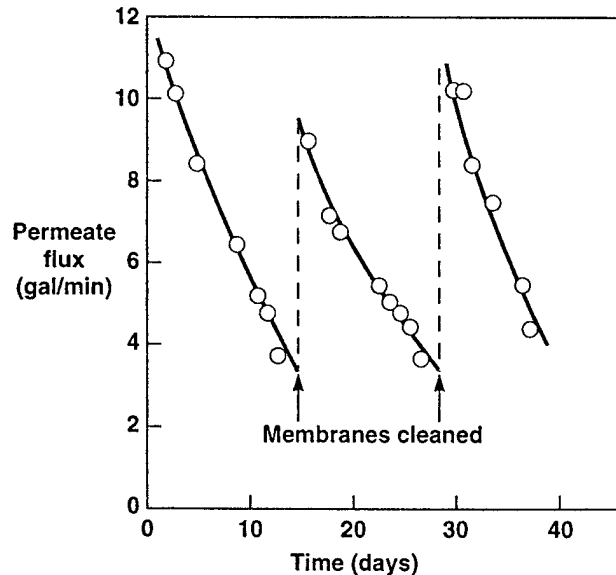

- 2 Ultrafiltration flux as a function of time for a latex emulsion. Because of fouling, the flux declines over a period of days. Periodic cleaning is required to maintain high fluxes.

If the regular cleaning cycle shown in Figure 2 is repeated many times, the membrane flux eventually does not return to the original value on cleaning. This slow, permanent loss of flux is due to internal fouling of the membrane by material that penetrates the membrane pores and becomes lodged in the interior of the membrane).

To overcome the problems of membrane fouling and the need for periodic cleaning, NC State University (NCSU) and Membrane Technology and Research, Inc. (MTR) developed a new type of composite membrane in which a thin, highly water-permeable polymer coating layer is used to completely eliminate internal membrane fouling and significantly reduce the effect of surface fouling. A microporous ultrafiltration support membrane is prepared first; this support is then coated with an extremely thin layer of a hydrophilic, water-swollen, but tough polymer. The configuration of this composite membrane is illustrated in Figure 3. We tried many coating materials during the course of this program, some available commercially and many synthesized and tested for the first time during this program. Results from these interim materials are well-documented in the progress reports submitted to SERDP during the course of this project. We obtained the best results with coating layers made from polyamide-polyether block copolymers (Pebax[®], Elf Atochem, Philadelphia, PA), which have the basic structure shown in Figure 4. The polyamide blocks provide mechanical strength; the polyether blocks allow for high water permeability.

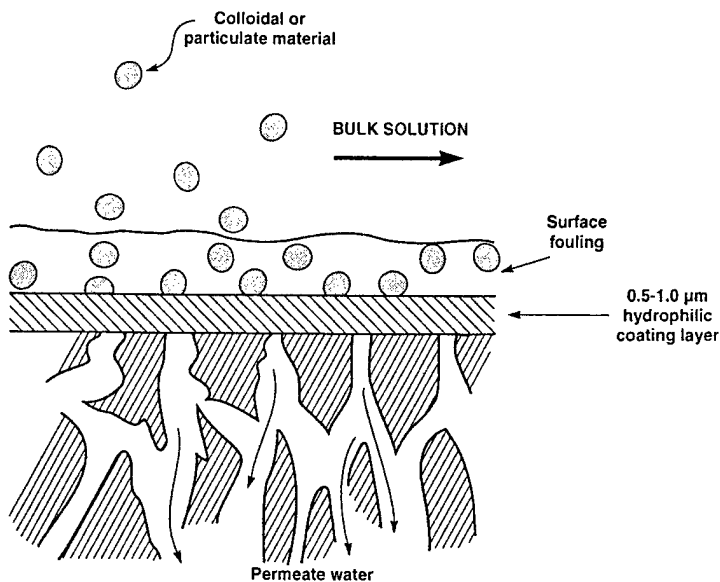

- 3 Schematic drawing of composite nanofiltration/ultrafiltration membrane in which a 0.5- to 1.0-micrometer-thick coating layer is used to eliminate internal membrane fouling and reduce the effect of surface fouling.

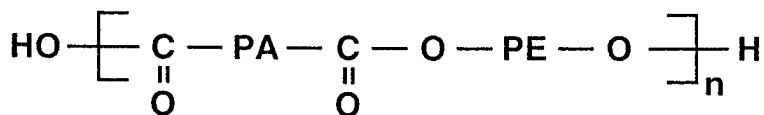

- 4 Repeat unit of polyamide (PA)-polyether (PE) block copolymers.

Coating the base ultrafiltration membrane with a thin polyamide-polyether layer produces a number of beneficial effects. First, internal membrane fouling is completely eliminated; colloids and particulates are retained by the coating layer and do not penetrate into the membrane pores. Therefore, the slow, irreversible decline in flux observed with conventional membranes does not occur. Second, the thin coating layer significantly enhances the rejection of the base membrane. For example, when tested with a 1% motor oil water emulsion our base membrane has an overall rejection of 90 to 95%, and the resulting permeate is still slightly cloudy. In contrast, the coated membrane has a rejection of more than 99%, and the permeate is completely clear. Also, the molecular weight cutoff of the uncoated membrane is about 50,000, whereas that of the coated membrane is about 5,000. Most importantly, the membrane flux is stable over long operating periods and can be regenerated to the original value without chemical treatment.

This was a three-year research project; the overall schedule for the project tasks is shown in Figure 5. The focus of the first year was selection and optimization of the membrane materials. In the second

year, membranes were prepared with industrial-scale equipment, a module test system was built, and the first bench-scale membrane modules were made. In the third year, the optimum membrane and module configuration was selected and several long-term runs were performed with solutions chosen to model shipboard wastewater.

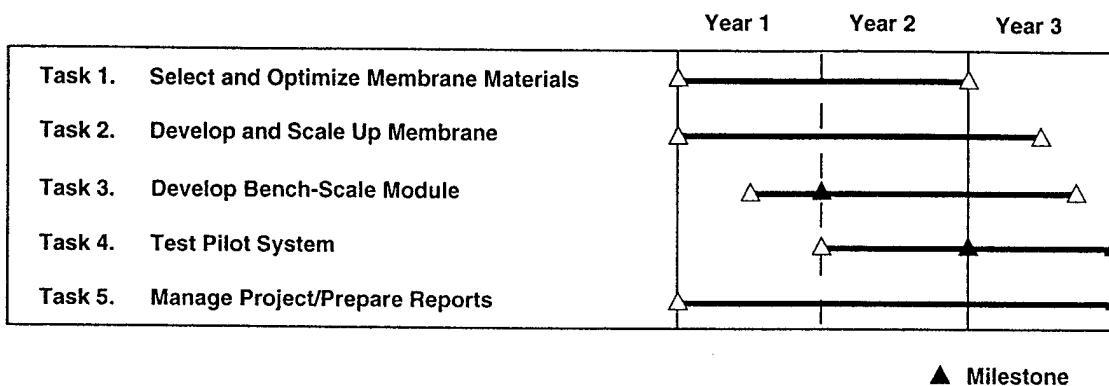

Figure 5. Project schedule.

2. RESULTS AND DISCUSSION

2.1 Membrane Preparation

The nanofiltration/ultrafiltration membranes used in this project consisted of a thin selective layer coated onto a microporous support membrane. Membrane production equipment at MTR was used for this two-step process.

The casting machine used to prepare the microporous support membrane is shown in Figure 6. The casting solution, consisting of a polymer dissolved in a water miscible-solvent, is doctored onto the moving web. The web passes into a water bath, which precipitates the polymer to form the film. The coated web is collected on a take-up roll, washed overnight to remove any remaining solvent and dried to form the support membrane.

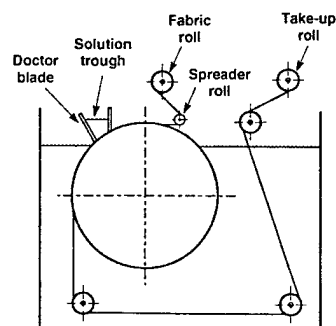

Figure 6. Schematic diagram of support membrane casting machine.

004-F

The apparatus used to apply the selective layer is shown in Figure 7. Support membrane from the feed roll passes into the coating tank, where a layer of polymer coating solution 50-100 micrometers thick is deposited. After solvent evaporation, a polymer film between 0.2 and 2.0 micrometers thick, depending on the polymer and the coating solution concentration, is left on the support membrane.

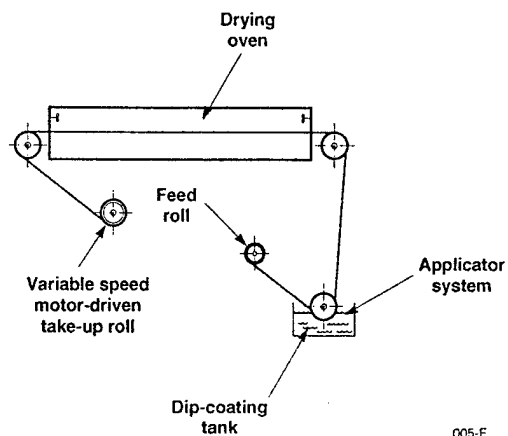

Figure 7. Schematic diagram of thin-film coating apparatus.

Three types of microporous support membrane were used during the project: poly(vinylidene fluoride) [PVDF], polysulfone [PSF], and polyetherimide [PEI]. In each case the microporous support was coated with a thin, nonporous layer of a Pebax polymer. Two hydrophilic grades, Pebax 4011 and 1074, were used for most of our work.

2.2 Composite Membrane Characterization

Gas permeation tests were used to determine the thickness of the Pebax layer and the integrity (absence of defects) of the membrane. Figure 8 shows a flow schematic of the pure gas test system.

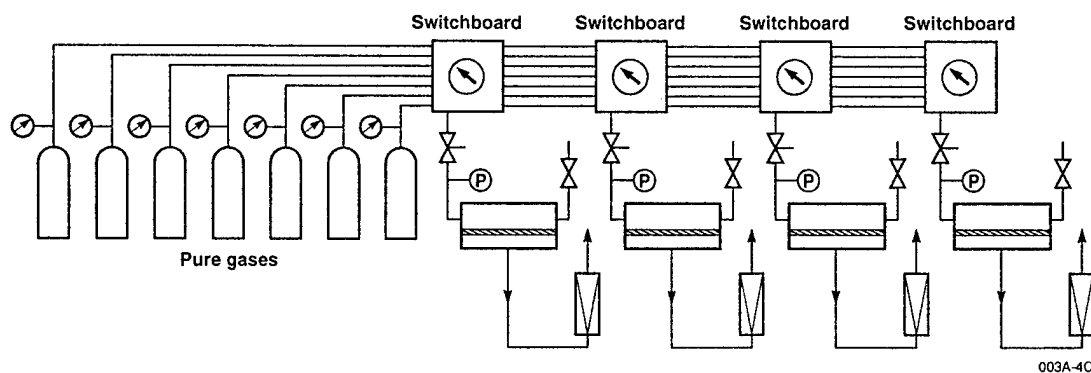

Figure 8. Schematic diagram of the test apparatus for measuring gas and vapor permeation through thin composite membranes. Because the membranes are thin, bubble flow meters can be used to measure the gas flow.

The rejection and flux characteristics of the membranes with solutions and emulsions were determined using the system shown in Figure 9. Up to six test cells can be connected in a series or parallel array to allow simultaneous side-by-side comparisons of several membrane stamps. Using this system, newly developed membranes were quickly screened to select the most promising for further study.

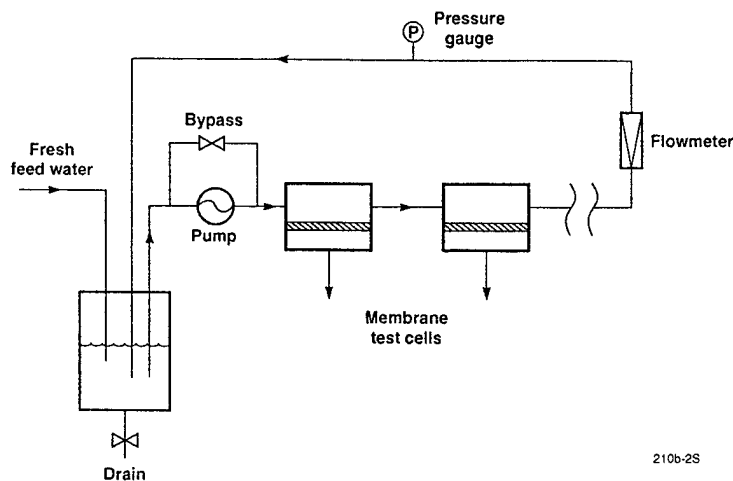

Figure 9. Simplified flow schematic of cross-flow test system with multiple test cells in series.

The flux and rejection were measured at each operational setting. The concentrations of the salt solutions were measured by conductivity, and the concentrations of the VOC solutions were measured by total organic carbon analysis (TOC) or gas chromatography.

2.3 Module Preparation

After completion of the membrane stamp tests, which demonstrated satisfactory performance of the Pebax 1074 and 4011 coated membrane, a series of rolls of 40-inch-wide membranes were prepared on industrial-scale equipment at MTR. This membrane was then used to fabricate bench-scale membrane modules. The winding operation used to prepare spiral membrane modules is shown schematically in Figure 10.

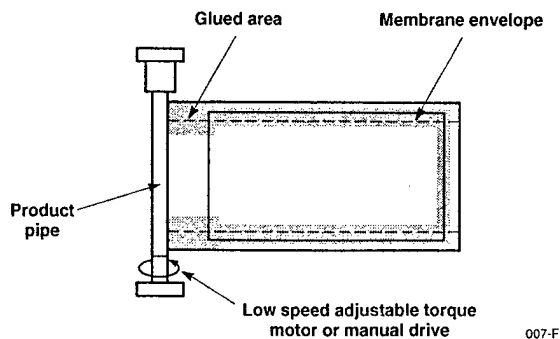

Figure 10. Schematic diagram of the module-winding operation.

The membrane is cut to size and folded around the feed-spacer material and the product distribution pipe. The membrane envelope is then moved to the wind-up machine. The product collection pipe is placed in the jaws of a motor clutch, and the spacer material is glued to the pipe. During the winding operation, the material is kept under slight tension, and the membrane envelope is glued along the edges and ends. When the operation is complete, a layer of reinforced tape is used to seal the module. The module is then fitted with end caps and placed in a pressure housing. A schematic diagram of a spiral-wound module is shown in Figure 11.

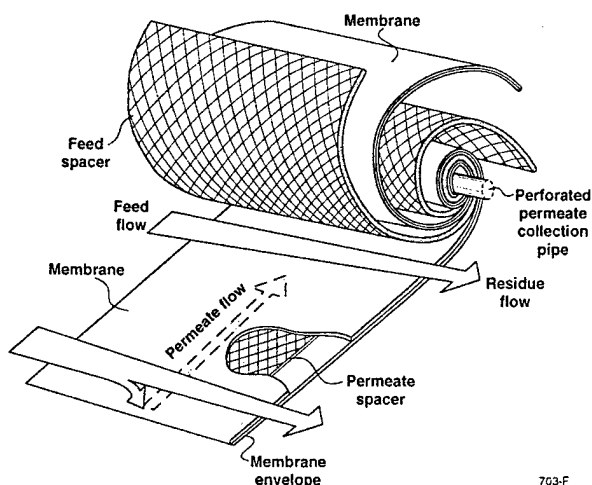

Figure 11. Schematic of spiral-wound module.

When preparing these membranes we had a number of problems with damage to the membranes by the feed spacer nettings. For example modules were prepared from Pebax membrane rolls that appeared to be defect-free and had carbon dioxide/nitrogen selectivities of 50 or more. However, the rolled modules had carbon dioxide/nitrogen selectivities of 3 to 5. The lower selectivity was due to a large increase in the nitrogen flux indicating membrane defects. Modules with low selectivities were dye tested by filling the feed side of the module with red dye solution and then drawing a vacuum on the permeate collection pipe. When the module is cut open, defects are apparent as small red marks. Dye test and visual inspection revealed very few membrane defects but it was difficult to obtain perfect modules. Some improvement was made by modifications to the module rolling procedure by placing less tension on the membrane, but perfect modules could not be made from this very thin composite membrane.

At this point a number of modules, shown to be apparently defective by the gas permeation tests, were tested with oil/water emulsions. The modules had oil emulsion rejections of greater than 99% and high fluxes; raffinose and PEG rejections were also comparable to the earlier membrane stamp data. Apparently, tiny membrane defects, which significantly affect the flux and selectivity of modules in tests with gases, have no measurable effect on modules in tests with aqueous emulsions and solutions. It is possible that swelling of the membrane by absorbed water closes defects present in the dry membrane.

2.4 Module Testing

Two module test systems were built for this program. A simplified flow diagram and a photograph of one of these units are shown in Figure 12. This system was originally built to operate with two 1 m^2 membrane modules but was later modified to operate with four modules. The system operates at feed pressure from 50 to 225 psig in a complete recirculation mode allowing continuous tests extending over several weeks to be performed. The permeate from each module can be collected and sampled separately so a continuous record of module performance can be obtained.

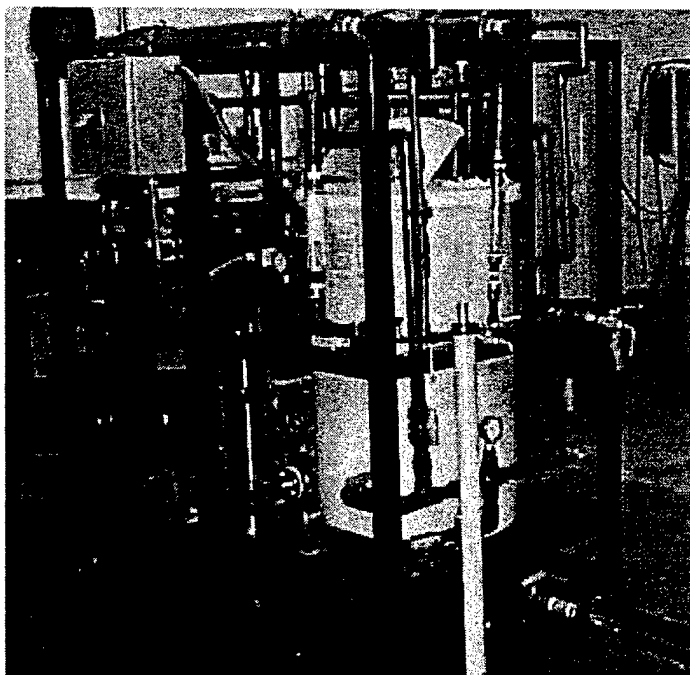
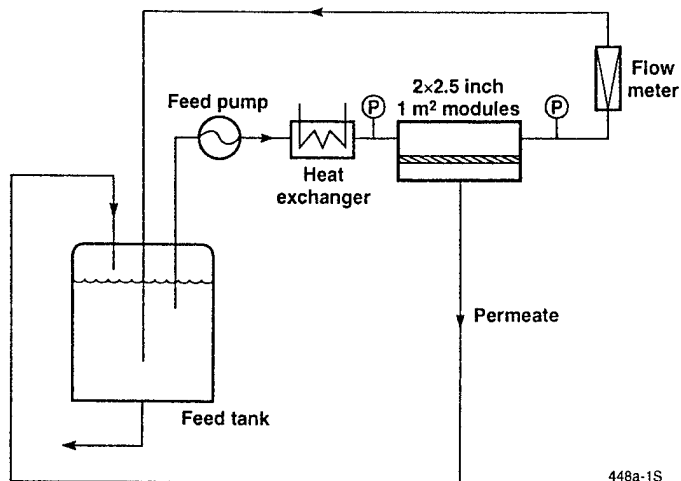

Figure 12. Flow schematic and photograph of one of the module test systems.

We found it much more difficult to completely wet membrane modules than membrane stamps. As a result, in some of our earlier tests, the module flux slowly increased during the first 10 days of operation as the membrane was gradually wetted and air was completely displaced from the PVDF support. To avoid this problem later modules were wetted before starting the tests by immersion in an ethanol solution and drawing a slight vacuum on the permeate side of the membrane. The module was then flushed with water to remove excess ethanol.

3. EXPERIMENTAL RESULTS AND DISCUSSION

3.1 Membrane Tests

Membranes were first tested by gas permeation to determine the thickness of the selective layer and its integrity (lack of defects). The water fluxes of defect-free membranes were determined and the membranes were also evaluated for chemical stability.

3.1.1 Membrane Characterization

The thickness of the selective Pebax layer was obtained in gas permeation tests by comparing the nitrogen flux of the composite membrane with the value for a thick isotropic film of the polymer. The absence of membrane defects was determined by comparing the nitrogen/carbon dioxide permeability ratio with the thick-film value. The thickness and number of defects in a membrane depend on the concentration and viscosity of the polymer coating solution, the method of applying the coating solution, and the properties of the support membrane. Defect-free layers as thin as 0.5 micrometers can be made. Some typical gas permeation test results obtained with the various support membranes and Pebax composite membranes are shown in Table 1.

Table 1. Gas Permeation Properties of Microporous Support Membranes [polysulfone, polyetherimide, and poly(vinylidene fluoride)] and Pebax 4011 and 1074 Thin-Film Composite Membranes.

Membrane Type	Pressure-Normalized Flux (10^{-6} cm ³ (STP)/cm ² ·s·cmHg)		Selectivity	Apparent Thickness of Pebax Layer (microns)
	N ₂	CO ₂	CO ₂ /N ₂	
Polysulfone [PSF]	15,000	14,000	0.9	—
1? % Pebax 4011/PSF	0.47	22	47	1.7
2? % Pebax 1074/PSF	0.8	47	56	1.0
Polyetherimide [PEI]	38,300	35,200	0.9	—
1? % Pebax 4011/PEI	0.93	50	54	0.9
Poly(vinylidene fluoride) [PVDF]	188,000	199,000	1.1	—
2? % Pebax 4011/PVDF	1.7	83	49	0.5
2? % Pebax 1074/PVDF	1.1	57	53	0.7

The Pebax 4011 and 1074 composite membranes were all essentially defect-free as indicated by a carbon dioxide/nitrogen selectivity of more than 40 for each one. The apparent thickness of the Pebax layer ranged from 0.5 to 1.7 micrometers for the various membranes. The gas permeation results also showed that the Pebax-coated PVDF membrane had higher pure gas fluxes and thinner Pebax layers than equivalent membranes prepared on polysulfone or polyetherimide. Water permeability tests confirmed this result, so relatively early in the project we selected poly(vinylidene fluoride) [PVDF] as our standard microporous support material.

During the first two years of the project, our standard Pebax membrane had an initial pure water flux of about 40-60 L/m²·h at 150 psig. Later we found that membranes with fluxes up to 200 L/m²·h or more could be prepared by modifying the membrane preparation procedure. Initially membranes were made by coating a 0.5% Pebax solution onto the support membrane at 70°C and 1 ft/min. However, decreasing the temperature to 50°C and decreasing the coating speed to 0.3 ft/min produced membranes with three to five times higher fluxes and equivalent separation properties. The reason for this very large effect is not clear. The number of Pebax coatings applied to the membrane was also important, as illustrated by some typical results shown in Figure 13. The results also show that the flux of the Pebax 1074 membrane is about half that of a Pebax 4011 membrane made under the same conditions. However, the Pebax 1074 membrane is also more retentive, as shown by the data in Tables 2 and 3. For example, the Pebax 1074 membrane has about 70% rejection for raffinose (MW 595), indicating an approximate molecular weight cutoff of 1,000 to 2,000. The Pebax 4011 had 40% rejection for PEG (MW 1,500) indicating a molecular weight cutoff of 5,000 or more.

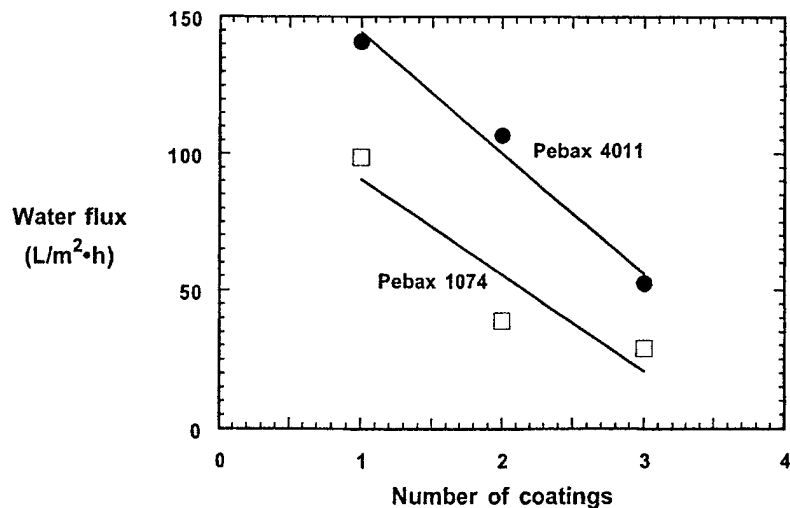

Figure 13. Water flux of Pebax composite membranes on a PVDF support as a function of the number of selective layer coatings with a 1% Pebax solution in butanol. The cross-flow permeation experiments were carried out at 100 psig pressure, 55 cm/s axial velocity, and 25°C. Feed solution was a model oily wastewater containing 900 ppm soybean oil and 100 ppm DC 193 surfactant.

Table 2. Solute Rejections of Pebax 1074/PVDF Composite Membrane. Feed pressure: 150 psig; feed flow rate: 0.34 gpm; feed temperature: 25°C; membrane area: 15.8 cm².

Solute	Solute Molecular Weight (g/mol)	Solute Rejection (%)
NaCl	58	10
MgSO ₄	120	47
Sucrose	342	49
D-Raffinose	595	69
SDS	288	25
DDAPS	308	12
BDHAC	395	73
Brij [®] 30	362	75
DC193	unknown	90

Table 3. Solute Rejections of 2% Pebax 4011/PVDF Composite Membrane. Feed pressure: 150 psig; feed flow rate: 0.34 gpm; feed temperature: 25°C; membrane area: 15.8 cm².

Solute	Solute Molecular Weight (g/mol)	Solute Rejection (%)
NaCl	58	3
NaHCO ₃	84	14
MgSO ₄	120	10
Na ₃ PO ₄	164	24
PEG900	900	33
PEG1500	1,500	42

3.1.3 Membrane Chemical Stability Evaluation

The Pebax copolymers contain amide bonds in the nylon blocks, so potential degradation of the membrane by high or low pH solutions or by chlorine was a concern. Therefore, a series of tests were performed to determine the chemical stability of the membranes. The Pebax 1074/PVDF composite membranes were immersed in buffer solutions of pH 2, 3, 5, 8, 10 and 12 and in aqueous solutions of sodium hypochlorite (NaOCl) at concentrations of 10, 50, 100 and 1,000 ppm for one week. The NaOCl solutions were changed every two hours on the first day and then once each day thereafter. The stability of the membranes was determined by measuring the nitrogen and carbon dioxide fluxes before and after the test and the water flux at 150 psig. The pure gas fluxes and selectivities are shown in Table 4.

Table 4. Effect of pH and Sodium Hypochlorite Concentration on the Gas Permeation Properties of Pebax 1074/PVDF Composite Membrane Soaked for One Week in the Test Solution. Membrane area: 12.6 cm²; feed pressure: 50 psig; feed temperature: 23 °C.

Soaking Solution	Pressure-Normalized Flux (10 ⁻⁶ cm ³ (STP)/cm ² ·s·cmHg)		Carbon Dioxide/Nitrogen Selectivity (-)
	Nitrogen	Carbon Dioxide	
Before Immersion	1.4	69	50
Buffer Solution pH			
2	4.1	116	29
3	3.5	102	30
5	1.5	59	40
8	2.7	125	46
10	4.7	138	30
12	Failed	—	—
NaOCl Concentration (ppm)			
10	3.2	133	42
50	3.5	123	36
100	3.4	131	38
1,000	Failed	—	—

The fluxes and selectivities of the membranes were essentially unaffected by exposure to solutions of pH between 3 and 10 or by exposure to NaOCl solutions containing up to 100 ppm NaOCl. Membranes exposed to very alkaline solutions of pH 12 or more and to a 1,000-ppm NaOCl solution both failed as shown by the very high fluxes and absence of selectivity in the gas permeation test. The membranes were then evaluated with aqueous solutions by measuring the water fluxes and rejections of a sodium chloride solution and of an oil/surfactant emulsion. The results are shown in Table 5.

Table 5. Water Fluxes and Solute Rejections of Pebax 1074/PVDF Composite Membranes After Being Soaked in Water, in Buffer Solutions of a Range of pHs, and in Sodium Hypochlorite Solutions for One Week. Membrane area: 15.8 cm²; feed pressure: 150 psig; feed temperature: 23°C; feed flow rate: 0.34 gpm.

Soaking Solution	1,500 ppm NaCl		1,000 ppm oil/surfactant	
	Water Flux (L/m ² h)	Rejection (%)	Water Flux (L/m ² h)	Rejection*
Untreated	35	13	32	92
Water	42	10	N/A	N/A
Buffer Solution pH				
2	62	12	46	92
3	42	12	36	92
5	29	13	27	90
8	33	12	30	90
10	60	15	60	91
12	65	16	56	90
NaOCl Concentration (ppm)				
10	31	11	38	92.3
50	25	11	32	92.5
100	45	10	N/A	N/A
1,000	24	15	N/A	N/A

* The oil emulsion used in this test contains 1,000 ppm oil and about 100 ppm surfactant. The membrane is slightly permeable to surfactant; therefore, a rejection of 90 to 95% corresponds to 100% rejection of the oil and 0 to 50% rejection of the surfactant.

The data in Table 5 show that the water fluxes and rejections of the membranes were essentially unaffected by exposure to the test solutions. From these experiments we conclude that the Pebax membrane is likely to be chemically stable under normal operating conditions. However, exposure to very high pH solutions or very concentrated hypochlorite during chemical cleaning may be a problem.

3.2 Module Tests

3.2.1 Test Solutions

Modules were initially evaluated with water and then with various motor oil or vegetable oil emulsions using a neutral surfactant (DC193, Dow Corning, Midland, MI) as the stabilizing surfactant. These emulsions were quite stable and showed no sign of phase separation even in experiments lasting several weeks. The Carderock Naval Warfare Test Station has also devised a number of mixtures to model Navy ship waste. The composition of the test mixture that most closely matches graywater is shown in Table 6. Although the total solids concentration of the mixture is only

3,800 ppm, the solution has a very high membrane fouling potential. Membrane fluxes gradually fell two- to four-fold when exposed to this mixture.

Table 6. Model Wastewater Composition.

Component	Amount for 100 gallons (g)	ppm
Tide Powdered Laundry Detergent	33.0	87
Laundry Starch	151.5	400
Gelatin	56.8	150
NH ₄ Cl	190.0	500
NaCl	66.6	175
Na ₃ PO ₄ ·12H ₂ O	72.0	82
NaHCO ₃	63.6	168
Canned Dog Food	757.6 (26.7 oz)	2,000
Crisco Solid Vegetable Shortening	26.5	70
Wesson oil	26.5	70
Directions		
Mix the components into the indicated amount of tap water. Heat to boiling for 30 minutes. Cool overnight and process the next day.		

3.2.2 Initial Flux and Rejection Tests

In a series of initial tests, the performance of Pebax 1074 modules was measured as a function of feed pressure, temperature and module flow rate with water as the test solution. The flux and rejection of various model solutions were also measured at the end of these tests under standard test conditions.

Figure 14 shows feed flow rate as a function of pressure drop across the module at various feed pressures. The feed-to-residue pressure drop of about 20 psig at a flow rate of 2 gpm was larger than expected. Therefore, we used a pressure drop of 10 psig as the base-case for module experiments; this is equivalent to a flow rate of about 1.1 gpm. Figures 15 and 16, respectively, show permeate water flux and pressure-normalized water flux as a function of average feed pressure. As expected, the water flux increases linearly with feed pressure and pressure-normalized water flux is independent of feed pressure. However, the water flux of the module was only 14 L/m²·h at 150 psig, half the expected value based on membrane cell tests. This occurred because the membrane was incompletely wetted.

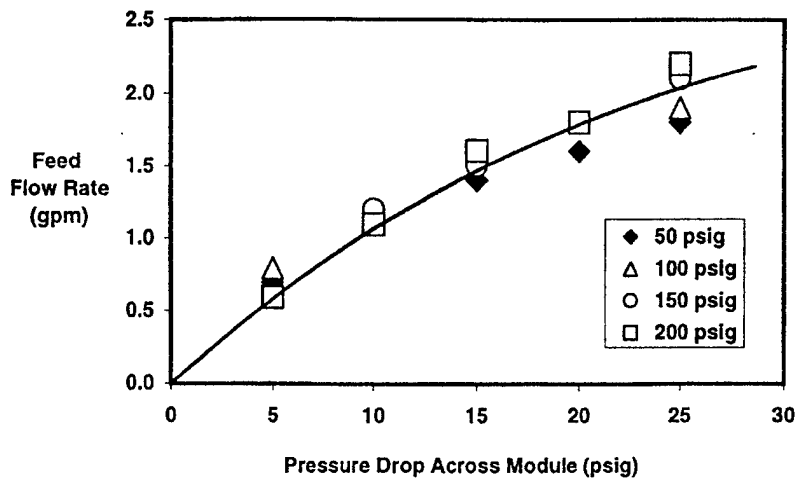

Figure 14. Feed flow rate of a Pebax 1074 module (#1510) as a function of pressure drop across the module. Feed solution: pure water; feed temperature: 21 °C; feed pressures: 50, 100, 150 and 200 psig; pressure drops across module: 5, 10, 15, 20 and 25 psig. Feed spacer: Nylon ROF030; permeate spacer: double Tricot 9944.

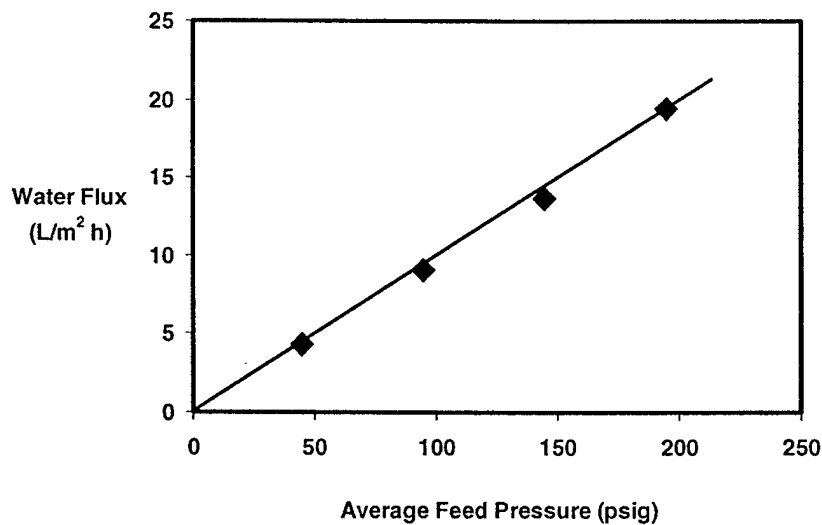

Figure 15. Water flux of a Pebax 1074 module (#1510) as a function of average feed pressure. Feed solution: pure water; feed temperature: 21 °C; feed pressures: 50, 100, 150 and 200 psig. Feed spacer: Nylon ROF030; permeate spacer: double Tricot 9944.

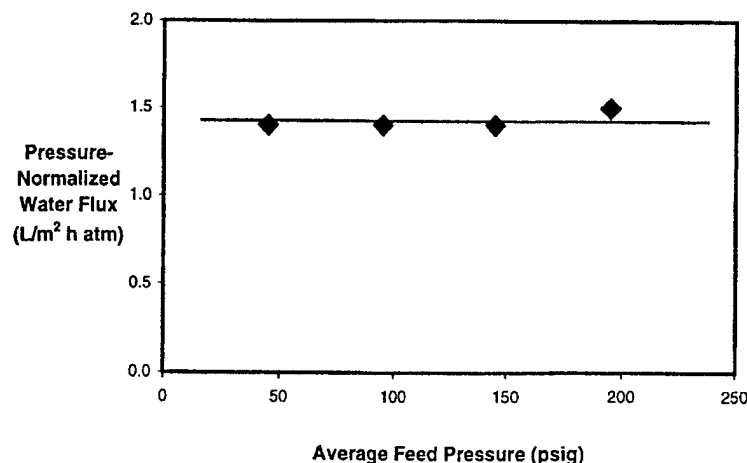

Figure 16. Pressure-normalized water flux of a Pebax 1074 module (#1510) as a function of average feed pressure. Feed solution: pure water; feed temperature: 21 °C; feed pressures: 50, 100, 150 and 200 psig. Feed spacer: Nylon ROF030; permeate spacer: double Tricot 9944.

The molecular weight cutoff of the Pebax 1074 module was then measured with a 1% motor oil emulsion and with polyethylene glycol, raffinose and toluene solutions. The tests were carried out at a feed pressure of 150 psig and a feed-to-residue pressure drop across the module of 10 psig. After tests with each solution, the system was flushed with water. The test data are given in Table 7. The membrane rejected essentially all of the motor oil emulsion. The permeate was completely clear and total organic carbon measurements showed less than 150 ppm organic carbon. The raffinose and PEG 3400 rejections were comparable to those measured earlier with membrane stamps. The molecular weight cutoff of the membrane is about 5,000.

Table 7. Water Fluxes and Solute Rejections of the Pebax 1074/PVDF Composite Membrane Module. Membrane area: 1 m²; feed pressure: 150 psig; feed-to-residue pressure drop: 10 psig; feed temperature: 23 °C.

Aqueous Solution	Molecular Weight (g/mol)	Pebax 1074/PVDF Module (#1565)	
		Water Flux (L/m ² ·h)	Rejection (%)
1% Motor Oil	N/A	43	99
1,000 ppm PEG	3,400	58	87
1,000 ppm Raffinose	595	62	41
250 ppm Toluene	92	55	11

3.2.3 Effect of Feed Spacers

The first modules tested were fabricated using the Nylon feed spacer and Tricot permeate spacer used in commercial pervaporation modules produced by MTR. However, because in this application the modules are likely to be operated with very dirty and highly fouling feeds, alternative, more open feed spacers were also evaluated. The properties of the candidate feed spacers tested are listed in Table 8.

Table 8. Candidate Feed Spacer Properties.

Spacer	Spacer Thickness (mil)	Configuration
ROF	25	90° Angle
ROF	30	0° Angle
ROF	30	90° Angle
MWN	48	—

Figure 17 shows the feed flow rate as a function of feed pressure for equivalent modules made with the three different spacers at a feed-to-residue pressure drop of 10 psi. The thicker MWN048 spacer has the highest flow rate and the ROF030 spacer the lowest. Based on these results, we selected the MWN048 spacer as our base-case feed spacer material.

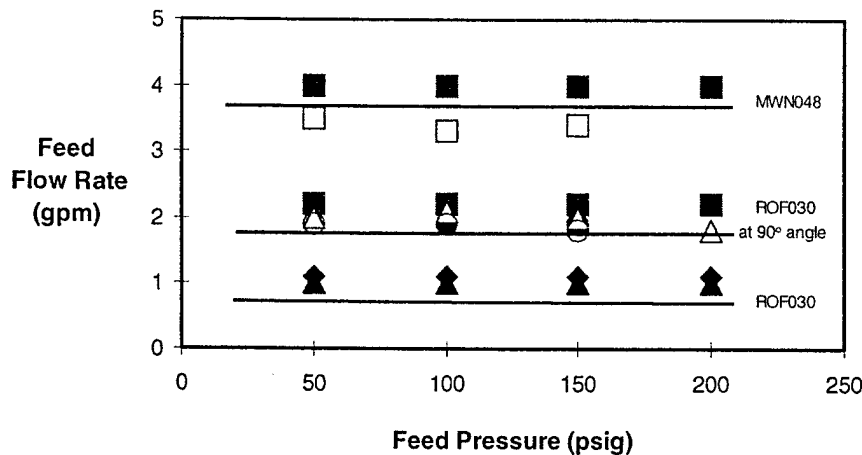

Figure 17. Feed flow rate as a function of average feed pressure for Pebax 1074 modules with various feed spacers

All modules were fitted with a single-layer Tricot 9944 permeate spacer; the membrane area was approximately 1 m². The modules were tested at 50 to 200 psig feed pressures and 5 to 20 psig feed-to-residue pressure drops across the modules. The modules were then operated with pure water; 1%, 2% and 3% motor oil emulsions; and finally with a 3,800-ppm graywater surrogate mixture over a

range of feed pressures. Figures 18(a) and (b) show the performance of Modules 1616 and 1617, respectively, which both had thin feed channel spacers. The results show clear evidence of concentration polarization and gel formation on the membrane surface. The oil-water emulsion fluxes increase with increasing pressure but then reach a limiting flux, after which any further increase in pressure does not increase the flux. Also, the limiting flux decreases with the fouling potential of the solution. For example, for Module 1616, the limiting flux with the 1% motor oil emulsion is 33 L/m²·h, with the 2% motor oil emulsion 28 L/m²·h, and with the 3% motor oil emulsion 20 L/m²·h. The surrogate graywater is extremely fouling, with a limiting flux of only 10 L/m²·h. In contrast, the data shown in Figure 18(c) for Module 1619, fitted with a 48-mil-thick feed spacer, was more encouraging. The module did not reach a limiting flux with motor oil emulsions, even at a flux of 50 L/m²·h. However, with the highly fouling surrogate graywater solution, a limiting flux of 18 L/m²·h was reached.

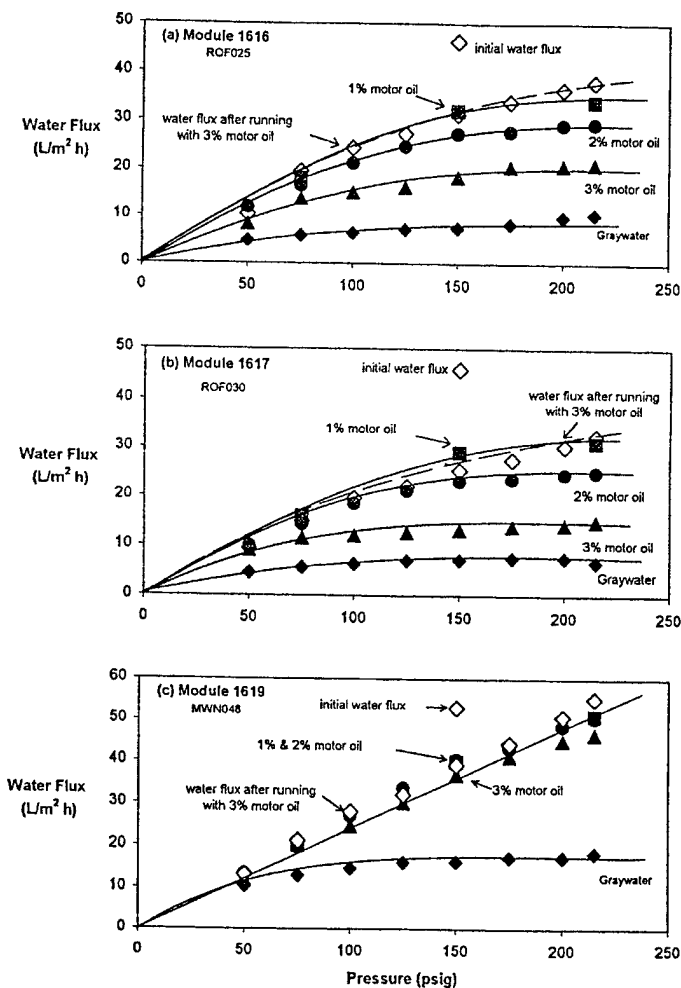

Figure 18. Water flux of Pebax 1074 modules having feed spacers (a) ROF025, (b) ROF030 and (c) MWN048 as a function of feed pressure. Temperature: 23 °C; pressures: 50 to 225 psig; feed-to-residue pressure drop across the module: 10 psig.

After the initial range-finding tests shown in Figures 16 and 17, the three test modules were operated at 150 psig feed pressure and a 10 psig feed-to-residue pressure drop across the modules for a further month. The data obtained are shown in Figure 19. First, the initial water fluxes of the modules were measured, then the water fluxes of the modules with 1%, 2% and 3% motor oil emulsions were measured. At the end of the eight-day motor oil emulsion tests, the system was flushed with water for three days and the water flux remeasured. Finally, the water fluxes of the modules were measured during operation with the graywater surrogate mixture for five days. After these tests, the modules were flushed with water and their fluxes measured again for comparison with their original values. Module 1619 with the thicker feed spacer, 48 mil, showed a significantly better performance than Modules 1616 and 1617, which had thinner feed spacers. It also appears that motor oil does not foul the Pebax membrane, but the graywater surrogate mixture does.

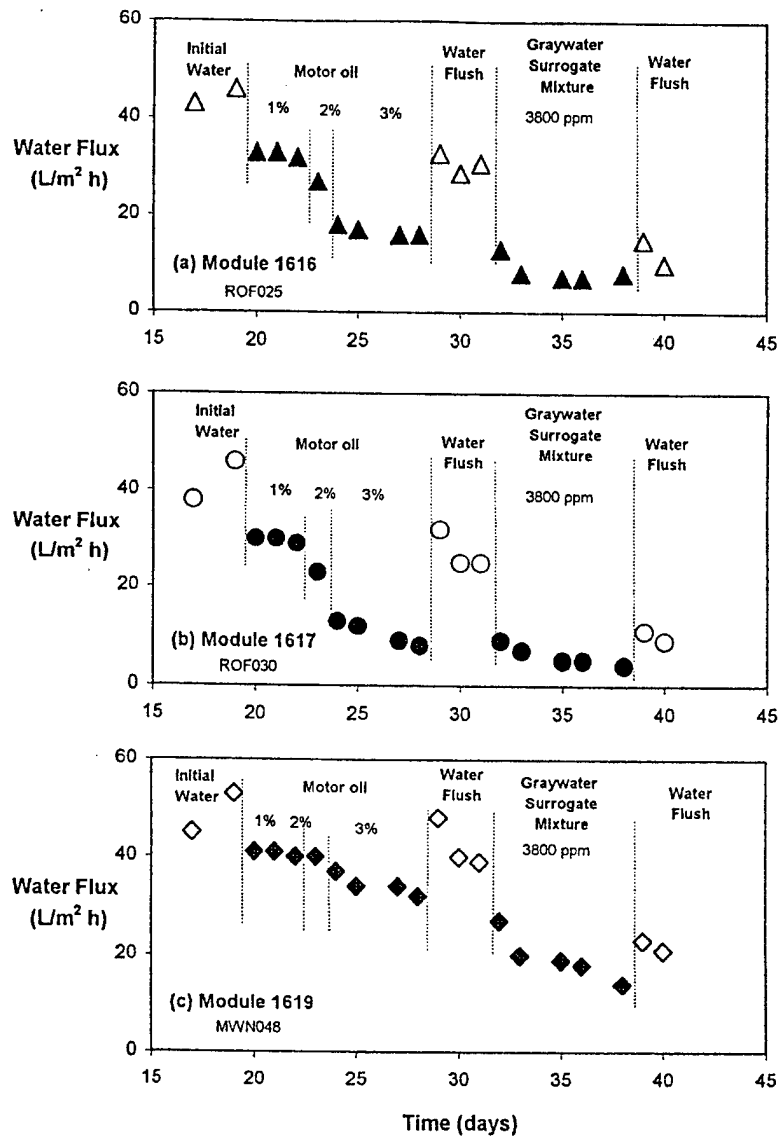

Figure 19. Water fluxes as a function of operating time for Pebax 1074/PVDF modules: (a) 1616 with an ROF025 spacer, (b) 1617 with an ROF030 spacer, and (c) 1619 with an MWN048 spacer. Temperature: 23 °C; pressure: 150 psig; feed-to-residue pressure drop across module: 10 psig.

3.2.4 Long-Term Tests

Several long-term tests to evaluate the performance of the Pebax spiral-wound modules with various feed solutions were performed. One such test to show the difference in performance of two equivalent bench-scale membrane modules, one using an uncoated PVDF ultrafiltration membrane and the other using the same membrane overcoated with a 0.5- to 1.0-micrometer thick Pebax 1074 layer is shown in Figure 20. Initially the uncoated PVDF membrane had a much higher flux than the coated membrane, but over a period of 22 days this flux declined 20-fold to approximately 12 L/m²·h. In contrast, the initially lower coated membrane flux (50 L/m²·h) was almost completely retained for the whole 22-day test. After the test period, both membranes were regenerated by flushing the system with clean water; no chemical additives or cleaning agents were used. The uncoated PVDF membrane only partially regained its original flux, showing that a large fraction of the flux decline was due to permanent internal membrane fouling. The flux of the coated membrane, however, returned to its original value. When both membranes were retested with the motor oil feed solution, the uncoated membrane flux quickly declined to a low value whereas the coated membrane maintained its previous high value.

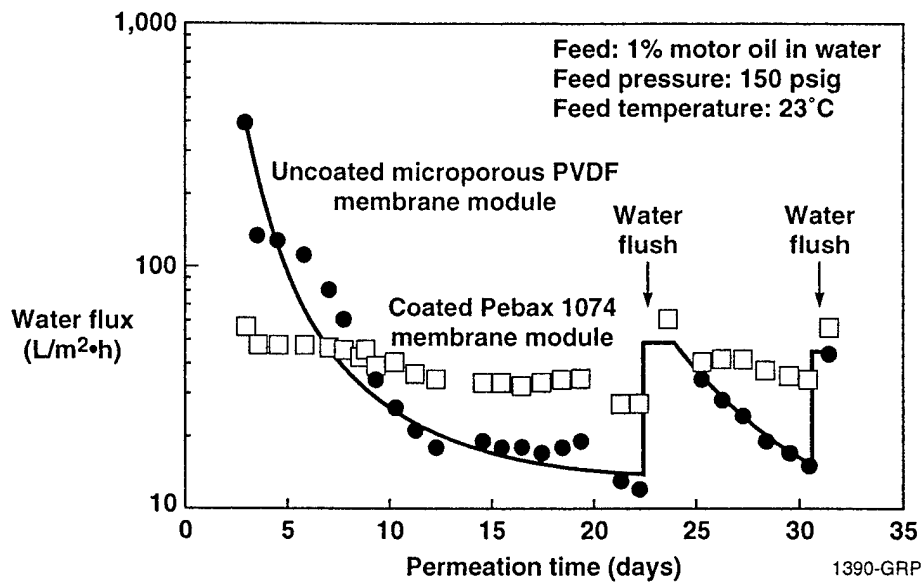

Figure 20. Change in flux over time for an uncoated microporous polyvinylidene fluoride (PVDF) ultrafiltration membrane module and the same membrane coated with a 0.5-1.0 micrometer polyether-polyamide layer (Pebax 1074). The PVDF module had a rejection of ~90%, the coated Pebax 1074 module had a rejection of more than 99%.

Similar results were obtained when currently available commercial ultrafiltration membranes were coated with Pebax. Figure 21 shows the performance of polysulfone tubular membranes produced by Zenon (Toronto, Canada) with and without a Pebax coating layer. The pure water flux of the uncoated Zenon membrane was 30 L/m²·h, and that of the coated membrane was a little lower at 28 L/m²·h. However, when tested with a 1,000-ppm oil/water emulsion the flux of the uncoated

membrane fell 10-fold to 2.5 L/m²·h, whereas that of the coated membrane was essentially unchanged at 25 L/m²·h.

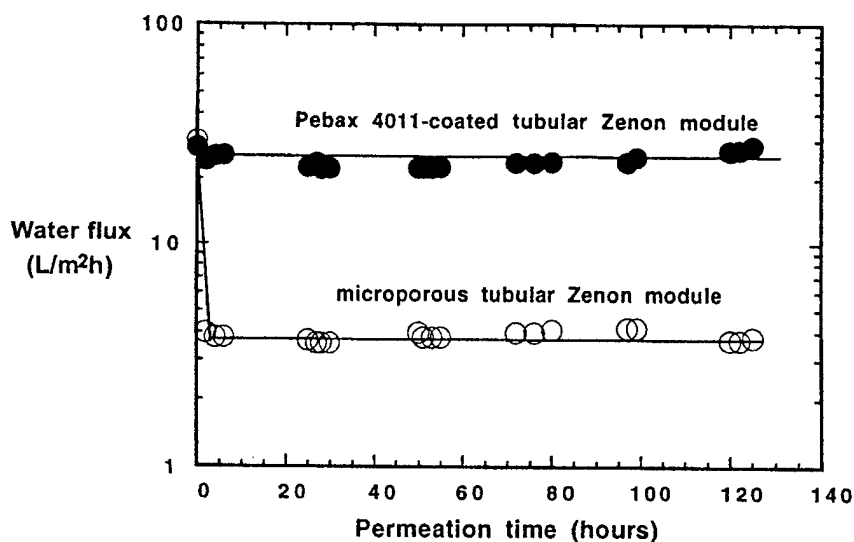

Figure 21. Water fluxes of uncoated and Pebax 4011-coated tubular Zenon membranes as a function of permeation time. Feed: 1,000 ppm soybean oil water emulsion; feed pressure: 20 psig; feed flow rate: 1.2 gpm; temperature: 25°C.

3.3 Module Cleaning

Several cleaning methods were evaluated for removal of the densified gel layer of retained materials from the membrane surface. The period of the cleaning cycle can vary from daily for food applications, such as ultrafiltration of whey, to once a month or more for ultrafiltration membranes used as polishing units in ultrapure water systems. A typical cleaning cycle is as follows:

1. Flush the system several times with hot water at the highest possible circulation rate.
2. Treat the system with an appropriate acid or alkali wash depending on the nature of the layer.
3. Treat the system with a hot detergent solution.
4. Flush the system thoroughly with water to remove all traces of detergent; measure the pure water flux through the membrane modules under standard test conditions.

Even after cleaning, some degree of permanent flux loss over time is expected. However, if the restoration of flux is less than expected, steps 1 through 3 are repeated.

However, the type of cleaning cycle shown above is not suitable for the low-maintenance requirements of Navy ships because of the need to use acidic or basic cleaning solutions. For most of our project we successfully cleaned membranes by circulating clean water through the modules

at high speed. Typical results are shown previously in Figure 20. Towards the end of this project a new module cleaning method called *in-situ* backflushing-flow reversal was developed. This procedure has considerable promise. A number of process developers have used methods such as flow pulsations and pressure variation to clean the membrane surface. The *in-situ* backflushing-flow reversal technique is illustrated in Figure 22.

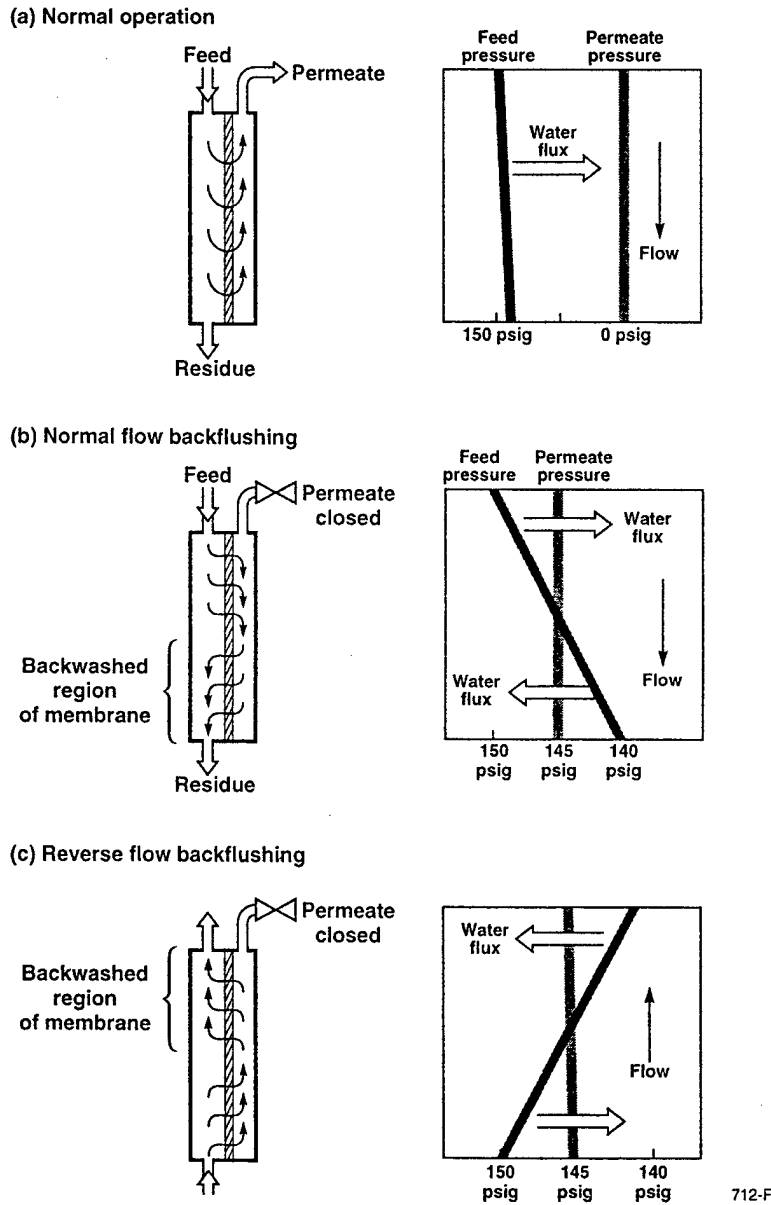

Figure 22. Backflushing, flow-reversal technique for cleaning membrane modules by closing the permeate port.

Figure 22(a) shows the membrane module in a normal operating mode. A pressure drop of about 10 psig exists across the membrane from the feed to the residue solution. This pressure difference is required to drive the feed solution through the module. The permeate pressure is close to atmospheric (0 psig). If the permeate port from the module is closed, the pressure on the permeate side of the membrane increases to a pressure intermediate between those of the feed and residue streams. This produces a slight positive pressure at one end of the module and a slight negative pressure at the other end of the module as shown in Figure 22(b). The back pressure difference sets up a backflushing condition in which permeate water that has permeated one-half of the module becomes a backflushing solution in the other half of the module. Deposited materials lifted from the membrane surface in the backflushed area are swept away by the fast feed flow. If the direction of the feed is reversed as shown in Figure 22(c), the other half of the module is then backflushed. This *in-situ* procedure allows a membrane module to be cleaned without stopping the normal operation of the membrane system. By using motor-driven valves, the entire procedure can be automated and set to clean the modules for a few minutes daily or even more frequently.

In the past this backflushing technique has been limited to low-pressure capillary ultrafiltration modules. Membranes in other modules are damaged by the reverse flow. However, the composite membranes we have developed are sufficiently tough to withstand this type of operation. Some preliminary results are shown in Figure 23. The starting point is a nanofiltration module used to concentrate an emulsion of 3.2 wt% motor oil. After 80 days of continuous operation, the membrane flux had fallen to 7 L/m²·h. At this point the permeate valve was closed and the back half of the module was backflushed for one hour; the flux doubled to 15 L/m²·h. After a further two days of normal operation the liquid flow was reversed, the permeate valve was again closed, and the second half of the module was backflushed for one hour. The membrane flux then rose to more than 30 L/m²·h. Clearly the backflushing, flow-reversal procedure is a powerful method of *in-situ* membrane cleaning without using chemicals or halting normal operation of the process.

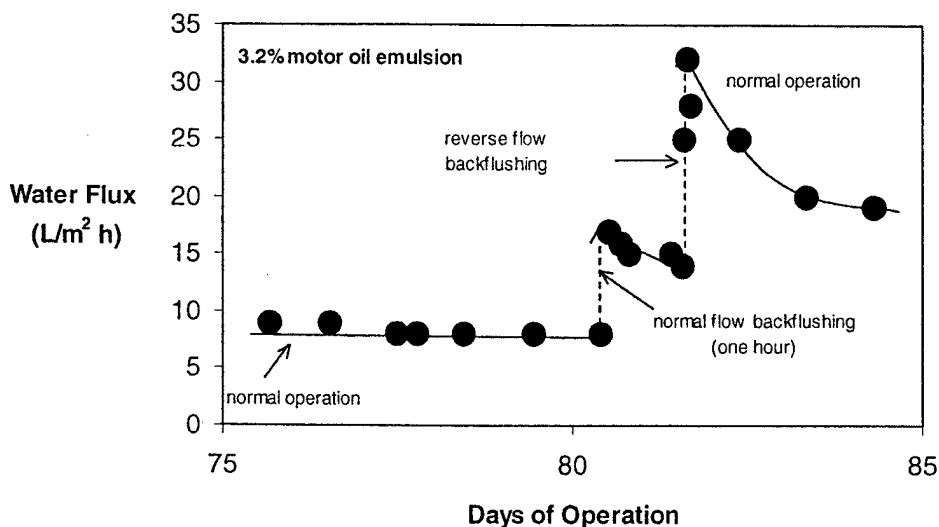

Figure 23. Backflushing, flow-reversal cleaning of a bench-scale nanofiltration Pebax 4011 composite membrane spiral-wound module. Feed solution was 3.2% motor oil at 150 psig.

4. CONCLUSIONS, TRANSITION PLAN AND RECOMMENDATIONS:

- Composite nanofiltration membranes prepared with laboratory- and industrial-scale membrane manufacturing equipment had water fluxes in the range 150 to 200 L/m²·h at 150 psig. Their molecular weight cutoff was between 5,000 and 10,000 dalton.
- Bench-scale membrane modules were very resistant to fouling with oil/water emulsions containing up to 5% oil in tests lasting up to 80 days and in tests with graywater surrogate mixtures. Stable fluxes of 50 L/m²·h were obtained with oil emulsions and 20-40 L/m²·h with graywater surrogate mixtures. The permeate from these membranes would meet the new discharge regulation set by the MARPOL agreement.
- The membrane modules can be cleaned satisfactorily by a clean water rinse cycle and even better by an *in-situ* backflushing, flow-reversal technique. This technique seems particularly suitable for shipboard oily and non-oily wastewater treatment systems.
- The technology is now ready for evaluation at the pilot-scale using a 1,000- to 5,000-gal/day unit able to operate pier-side to treat Navy ship wastewaters.

We recommend that the Navy consider a larger scale application of these very promising membranes for pierside graywater testing and also consider the possible use of such membranes for oil/water separation. An ESTCP or other similar program would be a very useful next step in the development of this technology.

APPENDIX A: Publications and Patents

Two peer-reviewed publications (attached) related to coating materials development has already been published and is attached. Several patent applications are in preparation at MTR and they will be forwarded to SERDP as soon as possible.