

**FINAL REPORT
NOVEMBER 2002**

REPORT NO. 02-23

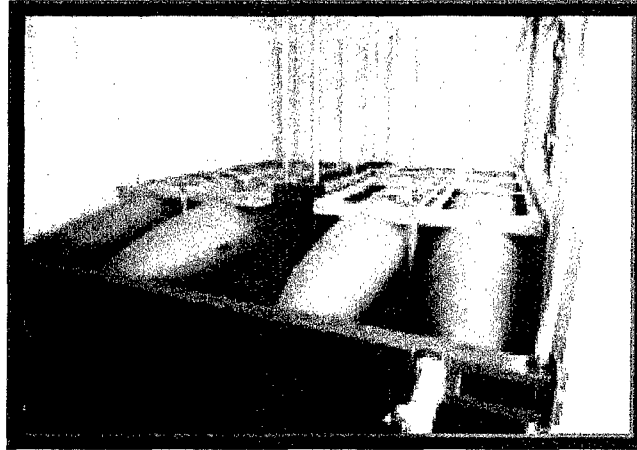

**RAPID INTERNATIONAL STANDARDS ORGANIZATION
BRACING SYSTEM (RIBS)
TP-94-01,
“TRANSPORTABILITY TESTING PROCEDURES”**

Prepared For:

U.S. Army Defense Ammunition Center
ATTN: SOSAC-DET
1 C Tree Road, Bldg 35
McAlester, OK 74501-9053

Distribution Unlimited:

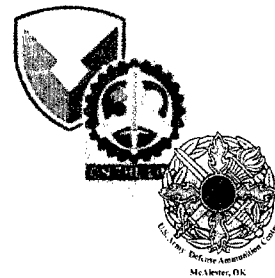

**VALIDATION ENGINEERING DIVISION
MCALESTER, OKLAHOMA 74501-9053**

20030103 262

AVAILABILITY NOTICE

A copy of this report will be furnished each attendee on automatic distribution. Additional copies or authority for reprinting may be obtained by written request from:

Director
U.S. Army Defense Ammunition Center
ATTN: SOSAC-DEV
1 C Tree Road, Bldg. 35
McAlester, OK 74501-9053

Reports may also be downloaded or viewed in PDF format from our web site at:

<http://www/dac.army.mil/DEV/TestReports>

DISTRIBUTION INSTRUCTIONS

Destroy this report when no longer needed. Do not return.

Citation of trade names in this report does not constitute an official endorsement.

The information contained herein will not be used for advertising purposes.

**REPORT NO. 02-23
RAPID INTERNATIONAL STANDARDS
ORGANIZATION BRACING SYSTEM (RIBS)
TP-94-01, "TRANSPORTABILITY TESTING PROCEDURES"**

NOVEMBER 2002

ABSTRACT

The U.S. Army Defense Ammunition Center (DAC), Validation Engineering Division (SOSAC-DEV), was tasked by the Transportation Engineering Division (SOSAC-DET) to conduct transportability testing using the Rapid International Standards Organization Bracing System (RIBS) material to secure munitions in both an intermodal side-opening and end-opening container. The RIBS was manufactured by Mobile Shelter Systems (MSS). The loading procedures specified in AMC Drawing 19-48-7127 were used as a guideline for securing the munitions in the side-opening container. The RIBS was substituted for the wood dunnage specified in AMC Drawing 19-48-7127, with the exception of the side wall/door panel gates. The loading procedures specified in AMC Drawing 19-48-4155 were used as a guideline for securing the munitions in an end-opening container. The RIBS was substituted for the wood dunnage specified in AMC Drawing 19-48-4155, with the exception of the side fill assemblies, separator gates and load bearing gate. The container loads were tested in accordance with TP-94-01, "Transportability Testing Procedures."

Transportability testing of the RIBS was initially conducted in June 2002. The testing was conducted using the RIBS in both an intermodal side-opening and end-opening container. The RIBS was damaged and failed transportability testing in an intermodal end-opening container. However, the RIBS successfully completed transportability testing in an intermodal side-opening container during the June 2002 testing.

Design changes were made to the RIBS and transportability testing in an intermodal end-opening container was conducted in September 2002. The RIBS successfully completed transportability testing in an intermodal end-opening container. Clips were successfully used to prevent the vertical stays from retracting down during transport during the June 2002 testing. The clips were not used during the September 2002 testing and the vertical stays retracted down during testing. Therefore, the clips are required to prevent the vertical stays from retracting during transport.

The RIBS is adequate for blocking and bracing of ammunition in intermodal side-opening and end-opening containers and successfully completed transportability testing in accordance with TP-94-01 "Transportability Testing Procedures". The approved RIBS components that were tested are identified in MSS Drawing as follows:

- (1) Ammo Cert 01015-RIBS Main Assembly
- (2) Ammo Cert 01015-A010-RIBS Bar
- (3) Ammo Cert 01015-A020-Vertical Stay
- (4) Ammo Cert 01015-A050-Horizontal Distance Stay (HDS)
- (5) Ammo Cert 01015-A060- Horizontal Distance Stay (HDS) Extender
- (6) Ammo Cert 01015-A080-Corner Cushion
- (7) Ammo Cert 01015-A200-RIB Cradle Medium Rect, Frame 2 Short + 2 Long
- (8) Ammo Cert 01015-A210-Cradle Beam Short
- (9) Ammo Cert 01015-A230-Cradle Beam Long

The RIBS components were tested 16-19 September 2002 and the RIBS cradle components were tested 4-7 June 2002.

Prepared by:

Reviewed by:

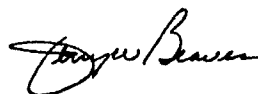
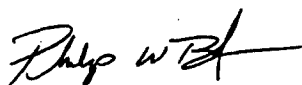

PHILIP W. BARICKMAN
Lead Validation Engineer

JERRY W. BEAVER
Chief, Validation Engineering Division

U.S. ARMY DEFENSE AMMUNITION CENTER

VALIDATION ENGINEERING DIVISION
MCALESTER, OK 74501-9053

REPORT NO. 02-23

Rapid International Standards Organization Bracing System (RIBS)
TP-94-01, "Transportability Testing Procedures"

TABLE OF CONTENTS

PART
PAGE NO.

1. INTRODUCTION	1-1
A. BACKGROUND.....	1-1
B. AUTHORITY.....	1-1
C. OBJECTIVE	1-1
D. CONCLUSION	1-1
2. ATTENDEES.....	2-1
3. TEST EQUIPMENT.....	3-1
4. TEST PROCEDURES	4-1
A. RAIL TEST	4-1
B. ON/OFF ROAD TESTS.....	4-3
1. HAZARD COURSE	4-3
2. ROAD TRIP	4-4
3. PANIC STOPS.....	4-4
4. WASHBOARD COURSE	4-4
C. OCEAN-GOING VESSEL TEST (STS).....	4-5
5. TEST RESULTS	5-1
5.1 TESTING DATE- (4-7 JUNE 2002)	5-1
A. RAIL TEST.....	5-1
B. ON/OFF ROAD TESTS.....	5-3
1. HAZARD COURSE.....	5-3
2. ROAD TRIP.....	5-4
3. PANIC STOPS.....	5-4
4. HAZARD COURSE.....	5-4
4. WASHBOARD COURSE.....	5-5
C. OCEAN-GOING VESSEL TEST (STS)	5-6
D. CONCLUSION.....	5-6

5.2 TESTING DATE- (4 JUNE 2002)	5-8
A. RAIL TEST	5-9
B. CONCLUSION.....	5-11
5.3 TESTING DATE- (11 JUNE 2002)	5-12
A. RAIL TEST	5-13
B. CONCLUSION.....	5-15
5.4 TESTING DATE- (16-19 SEPTEMBER 2002)	5-16
A. RAIL TEST	5-18
B. ON/OFF ROAD TESTS	5-20
1. HAZARD COURSE	5-20
2. ROAD TRIP	5-21
3. PANIC STOPS	5-21
4. HAZARD COURSE	5-21
4. WASHBOARD COURSE.....	5-22
C. OCEAN-GOING VESSEL TEST (STS)	5-22
D. CONCLUSION.....	5-23
6. ACCELEROMETER DATA.....	6-1
7. DRAWINGS.....	7-1

PART 1 – INTRODUCTION

A. BACKGROUND. The U.S. Army Defense Ammunition Center (DAC), Validation Engineering Division (SOSAC-DEV), was tasked by the Transportation Engineering Division (SOSAC-DET) to conduct transportability testing using the Rapid International Standards Organization Bracing System (RIBS) material to secure munitions in both an intermodal side-opening and end-opening container. The RIBS was manufactured by Mobile Shelter Systems (MSS). The loading procedures specified in AMC Drawing 19-48-7127 were used as a guideline for securing the munitions in the side-opening container. The RIBS was substituted for the wood dunnage specified in AMC Drawing 19-48-7127, with the exception of the side wall/door panel gates. The loading procedures specified in AMC Drawing 19-48-4155 were used as a guideline for securing the munitions in an end-opening container. The RIBS was substituted for the wood dunnage specified in AMC Drawing 19-48-4155, with the exception of the side fill assemblies, separator gates and load bearing gate. The container load was tested in accordance with TP-94-01, "Transportability Testing Procedures."

B. AUTHORITY. This test was conducted IAW mission responsibilities delegated by the U.S. Army Operations Support Command (OSC), Rock Island, IL. Reference is made to the following:

1. AR 740-1, 15 June 2001, Storage and Supply Activity Operation.
2. IOC-R, 10-23, Mission and Major Functions of USADAC, 7 January 1998.

C. OBJECTIVE. The objective of the testing was to validate using the RIBS as an alternative to wood for blocking and bracing munitions in both a side-opening and an intermodal end-opening container.

D. CONCLUSION. Transportability testing of the RIBS was initially conducted in June 2002. The testing was conducted using the RIBS in both an intermodal side-opening and end-opening container. The RIBS was damaged and failed transportability testing in an intermodal end-opening container. However, the RIBS successfully completed transportability testing in an intermodal side-opening container during the June 2002 testing. Design changes were made to the RIBS and transportability testing in an intermodal end-opening container was conducted in September 2002. The RIBS successfully completed transportability testing in an intermodal end-opening container. Clips were successfully used to prevent the vertical stays from retracting down during transport during the June 2002 testing. The clips were not used during the September 2002 testing and the vertical stays retracted down during testing. Therefore, the clips are required to prevent the vertical stays from retracting during transport.

The RIBS is adequate for blocking and bracing of ammunition in intermodal side-opening and end-opening containers and successfully completed transportability testing in accordance with TP-94-01 "Transportability Testing Procedures". The approved RIBS components that were tested are identified in MSS Drawing as follows:

- (1) Ammo Cert 01015-RIBS Main Assembly
- (2) Ammo Cert 01015-A010-RIBS Bar
- (3) Ammo Cert 01015-A020-Vertical Stay
- (4) Ammo Cert 01015-A050-Horizontal Distance Stay (HDS)
- (5) Ammo Cert 01015-A060- Horizontal Distance Stay (HDS) Extender
- (6) Ammo Cert 01015-A080-Corner Cushion
- (7) Ammo Cert 01015-A200-RIB Cradle Medium Rect, Frame 2 Short + 2 Long
- (8) Ammo Cert 01015-A210-Cradle Beam Short
- (9) Ammo Cert 01015-A230-Cradle Beam Long

The RIBS components were tested 16-19 September 2002 and the RIBS cradle components were tested 4-7 June 2002.

PART 2 - ATTENDEES

ATTENDEE

MAILING ADDRESS

Philip Barickman
General Engineer
DSN 956-8992
(918) 420-8992

Director
U.S. Army Defense Ammunition Center
ATTN: SOSAC-DEV
1 C Tree Road, Bldg. 35
McAlester, OK 74501-9053

Richard Garside
General Engineer
DSN 956-8050
(918) 420-8050

Director
U.S. Army Defense Ammunition Center
ATTN: SOSAC-DET
1 C Tree Road, Bldg. 35
McAlester, OK 74501-9053

Gregory L. Willis
Industrial Engineer
DSN 956-8075
(918) 420-8075

Director
U.S. Army Defense Ammunition Center
ATTN: SOSAC-DET
1 C Tree Road, Bldg. 35
McAlester, OK 74501-9053

James Mitchell
Executive Vice President of
Marketing and Operations
(757) 229-9482

Mobile Shelter Systems
4039 Ironbound Road
Williamsburg, VA 23188

Alonza A. McWhite
Director of Domestic and
Overseas Operations
(757) 229-0059

Mobile Shelter Systems
4039 Ironbound Road
Williamsburg, VA 23188

Lars Aamodt
47 33360690

Mobile Shelter Systems AS
Industrigata 3
N-3160 Stokke, Norway

PART 3 - TEST EQUIPMENT

1. Rapid International Standards Organization Bracing System (RIBS)
Manufactured by Mobile Shelter System

2. Intermodal Side-Opening Container, 20-foot long
Date of Manufacture: 06/89
Manufactured by Containertechnik, Hamburg, Germany
ID # USAF 002 2053
Maximum Gross Weight: 52,910 pounds
Tare Weight: 6,050 pounds
Used during the June 2002 testing.

3. Intermodal End-Opening Container, 20-foot long
Date of Manufacture: 12/96
Manufactured by Siam Cargo Container Ltd., Thailand
ID # MLCU 3211 090
Maximum Gross Weight: 67,200 pounds
Tare Weight: 4,850 pounds
Used during the June 2002 and September 2002 testing.

4. Truck, Tractor
5 Ton, 6 X 6
Model #: XM818 with winch
ID #: 05A-74971-C124-13529
Weight: 20,955 pounds

5. Semitrailer, flatbed, breakbulk/container transporter, 22.5 ton

Model #: M871

Manufactured by Southwest Truck Body, St. Louis, MO

ID #: NX03PJ – 0063

NSN: 2330 00 122 6799

Weight: 15,630 pounds

Used during the June 2002 testing

6. Semitrailer, flatbed, breakbulk/container transporter, 34-ton

Model #: M872A1

Manufactured by Heller Truck Body Corp., Hillsdale, NJ

ID #: 11-1505 NX05NZ

NSN: 2330 01 109 8006

Weight: 19,240 pounds

Used during the September 2002 testing.

PART 4 - TEST PROCEDURES

The test procedures outlined in this section were extracted from TP-94-01, "Transportability Testing Procedures," July 1994, for validating tactical vehicles and outloading procedures used for shipping munitions by tactical truck, railcar, and ocean-going vessel.

Inert (non-explosive) items will be used to build the load. The test loads will be prepared using the blocking and bracing procedures proposed for use with munitions (**see Part 7 for procedures**). The weight and physical characteristics (weights, physical dimensions, center of gravity, etc.) of the test loads will be similar to live (explosive) ammunition.

A. RAIL TEST. RAIL IMPACT TEST METHOD. The test load or vehicle will be secured to a flatcar. The equipment needed to perform the test will include the specimen (hammer) car, four empty railroad cars connected together to serve as the anvil, and a railroad locomotive. The anvil cars will be positioned on a level section of track with air and hand brakes set and with draft gears compressed. The locomotive unit will push the specimen car toward the anvil at a predetermined speed, then disconnect from the specimen car approximately 50 yards away from the anvil cars allowing the specimen car to roll freely along the track until it strikes the anvil. This will constitute an impact. Impacting will be accomplished at speeds of 4, 6, and 8.1 mph in one direction and at a speed of 8.1 mph in the reverse direction. The speeds will have a tolerance of plus .5 mph and minus zero mph. The impact speeds will be determined by using an electronic counter to measure the time for the specimen car to traverse an 11-foot distance immediately prior to contact with the anvil cars (see Figure 1).

ASSOCIATION OF AMERICAN RAILROADS (AAR)

STANDARD TEST PLAN

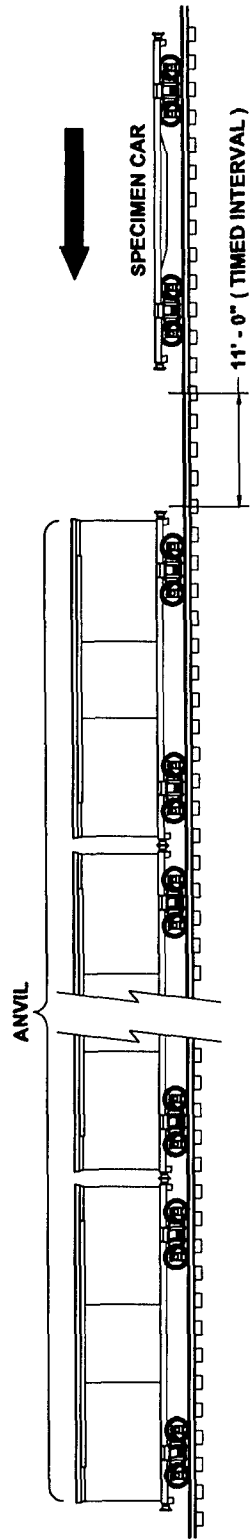

4 BUFFER CARS (ANVIL)
WITH DRAFT GEAR COMPRESSED
AND AIR BRAKES IN A SET POSITION

ANVIL CAR TOTAL WT. 250,000 LBS (APPROX)

SPECIMEN CAR IS RELEASED BY SWITCH ENGINE
TO

ATTAIN: IMPACT NO. 1 @ 4 MPH

IMPACT NO. 2 @ 6 MPH

IMPACT NO. 3 @ 8.1 MPH

THEN THE CAR IS REVERSED AND RELEASED BY
SWITCH ENGINE TO ATTAIN:

IMPACT NO. 4 @ 8.1 MPH

Figure 1. Rail Impact Sketch

B. ON/OFF ROAD TEST.

1. **HAZARD COURSE.** The test load or vehicle will be transported over the 200-foot-long segment of concrete-paved road consisting of two series of railroad ties projecting 6 inches above the level of the road surface. The hazard course will be traversed two times (see Figure 2).

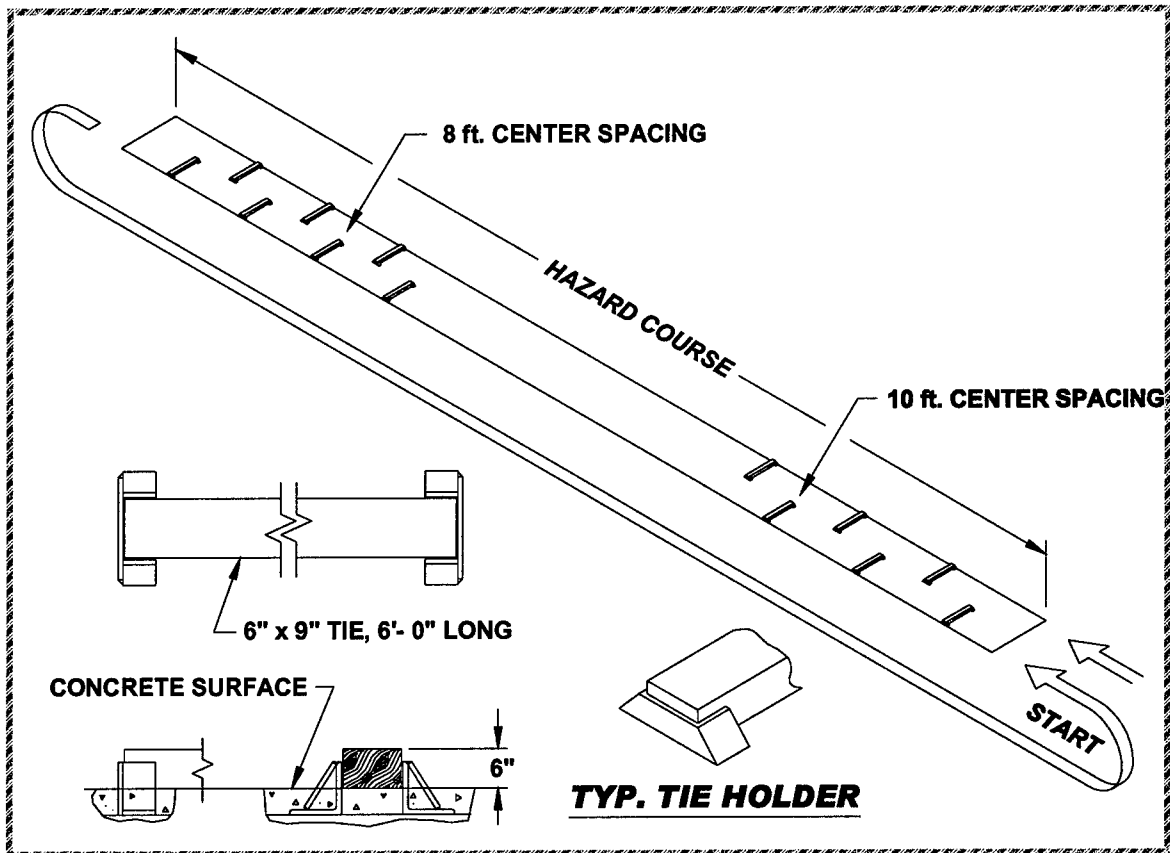

Figure 2. Hazard Course Sketch

- a. The first series of 6 ties are spaced on 10-foot centers and alternately positioned on opposite sides of the road centerline for a distance of 50 feet.
- b. Following the first series of ties, a paved roadway of 75 feet separates the first and second series of railroad ties.

c. The second series of 7 ties are spaced on 8-foot centers and alternately positioned on opposite sides of the road centerline for a distance of 50 feet.

d. The test load is driven across the hazard course at speeds that will produce the most violent vertical and side-to-side rolling reaction obtainable in traversing the hazard course (approximately 5 mph).

2. ROAD TRIP. The test load or vehicle will be transported for a distance of 30 miles over a combination of roads surfaced with gravel, concrete, and asphalt. The test route will include curves, corners, railroad crossings and stops and starts. The test load or vehicle will travel at the maximum speed for the particular road being traversed, except as limited by legal restrictions.

3. PANIC STOPS. During the road trip, the test load or vehicle will be subjected to three (3) full airbrake stops while traveling in the forward direction and one in the reverse direction while traveling down an approximate 7 percent grade. The first three stops are at 5, 10, and 15 mph while the stop in the reverse direction is approximately 5 mph. This testing will not be required if the Rail Impact Test is performed.

4. WASHBOARD COURSE. The test load or vehicle will be driven over the washboard course at a speed that produces the most violent response in the vertical direction.

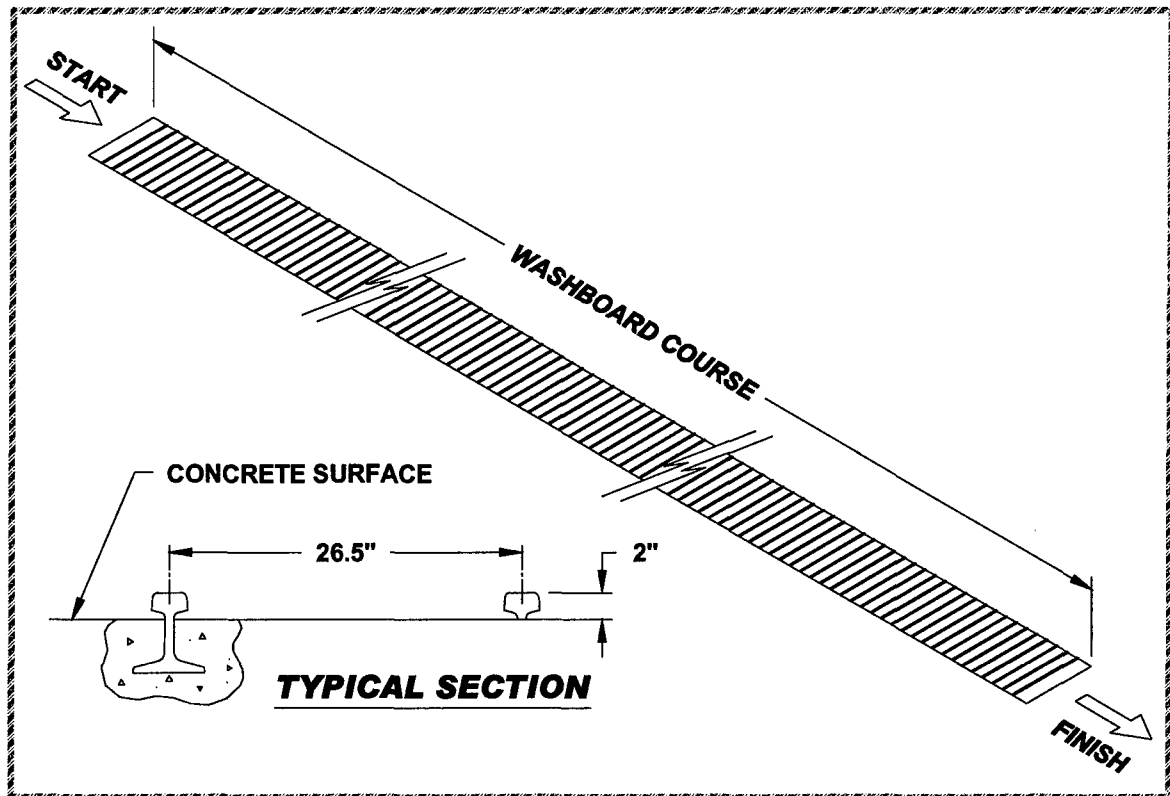

Figure 3. Washboard Course Sketch

C. OCEAN-GOING VESSEL TEST. SHIPBOARD TRANSPORTATION SIMULATOR (STS) TEST METHOD. The test load will be secured inside an ISO container and will be positioned onto the STS and securely locked in place using the cam locks at each corner. Oscillation of the STS will be started and rotate to an angle of 30 degrees plus or minus 2 degrees, either side of center and at a frequency of 2 cycles-per-minute (30 seconds, plus or minus 2 seconds total roll period). This frequency will be observed for apparent defects that could cause a safety hazard. The frequency of oscillation will then be increased to 4 cycles-per-minute (15 seconds, plus or minus 1 second per roll period) and the apparatus operated a period of two (2) hours. An inspection of the load will then be conducted. If the inspection does not indicate an impending failure, the frequency of oscillation will be further increased to 5 cycles-per-minute (12 seconds, plus or minus 1 second-cycle time), and the apparatus operated for four (4) hours. The operation does not necessarily have to be continuous, however, no change or adjustments to the load or load restraints will be permitted at any

time during the test. After once being set in place, the test load (specimen) will not be removed from the apparatus until the test has been completed or is terminated

PART 5 - TEST RESULTS

5.1 Payload: RIBS with MK-84, 2000-Pound Bombs

Gross Weight: 38,095 Pounds

Testing Date: 4-7 June 2002



Photo 1. RIBS with MK-84, 2000-Pound Bombs

A. RAIL TEST. RAIL IMPACT TEST.

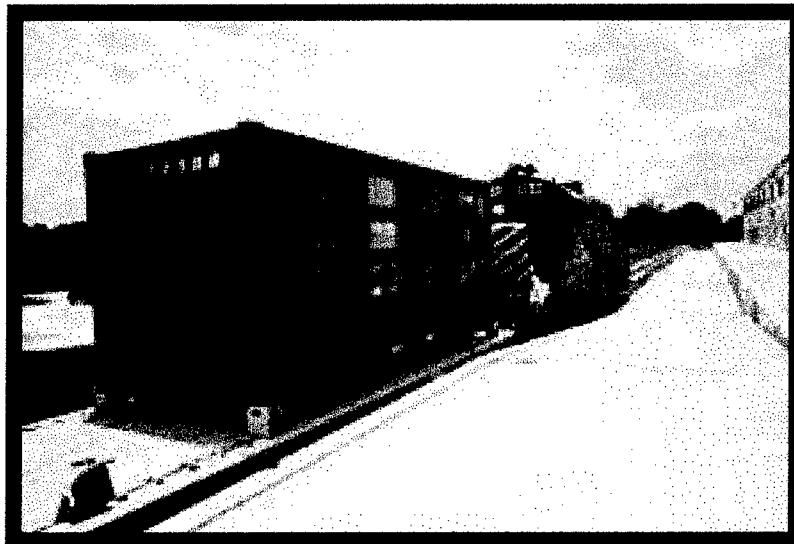

Photo 2: Rail Impact Testing of the RIBS

Description	Weight
Flatcar Number: DODX 48797	62,700 lbs.
Intermodal side opening container with MK-84 Bombs & RIBS	38,095 lbs.
M1 Flatrack with MLRS Pods	28,265 lbs.
Total Specimen Wt.	129,060 lbs.
Buffer Car (four cars)	250,000 lbs.

Figure 4.

Remarks: Figure 4 lists the test components and weights of the items used during the Rail Impact Tests. The intermodal container, with the RIBS and payload, was secured on the Container-on-Flatcar (COFC) railcar. The M1 Flatrack, loaded with MLRS Pods was used as ballast for the test.

Impact Number	Avg. Velocity (mph)
1	4.1
2	6.7
3	8.6
4	8.0
5	8.6

Figure 5.

Remarks:

- Figure 5 lists the average speeds of the specimen car immediately prior to impact with the anvil. Impact #5 is the reverse impact.
- Impact #4 was determined to be a "no test" due to the impact speed was less than the required 8.1 mph. The test was repeated.
- Following impact #3 the payload compacted 0.125 inches in the direction of impact. The bombs in the center pushed the beams up slightly.

4. Following Impact #5 the beams at each end of the container moved 0.25 inches in each corner and 0.5 inches in the center. The center vertical stays moved 0.75 inches. All movement was in the direction of impact.

B. ON/OFF ROAD TESTS.

1. HAZARD COURSE.



Photo 3: Hazard Course Testing of the RIBSs

Pass No.	Elapsed Time	Avg. Velocity (mph)
1	30 Seconds	4.9
2	27 Seconds	5.4

Figure 6.

Remarks:

1. Figure 6 lists the average speeds of the test load through the Hazard Course.
2. Inspection following Pass #1 revealed that the payload and beams moved to the original starting position. The cradle movement from the beginning of testing was 0.75 inches.

3. Inspection following Pass #2 revealed that the cradle at the rear of the trailer had moved an additional 0.25 inches.

4. No damage or excessive movement occurred with the payload or the RIBS during Passes #1 and #2.

2. **ROAD TRIP**: No damage or excessive movement occurred with the payload or the RIBS.

3. **PANIC STOPS**: Testing was not required since the RIBS had been rail impact tested.

4. **HAZARD COURSE.**

Pass No.	Elapsed Time	Avg. Velocity (mph)
3	30 Seconds	4.9
4	27 Seconds	5.4

Figure 7

Remarks:

1. Figure 7 lists the average speeds of the test load through the Hazard Course Passes #3 and #4.

2. No damage or excessive movement occurred with the payload or the RIBS during Passes #3 and #4.

5. **WASHBOARD COURSE:**



Photo 4. Washboard Course Testing of the RIBS

Remarks:

1. The total movement of the cradle was 0.75 inches at the trailer end of the container and 1.5 inches at the tractor end of the container. The movement was at the top of the cradles and not at the base.
2. No damage or excessive movement occurred with the payload or the RIBS during testing.

**C. OCEAN-GOING VESSEL TEST. SHIPBOARD TRANSPORTATION
SIMULATOR (STS) TEST METHOD.**



Photo 5: STS Testing of the RIBS

Remarks:

1. The beams moved 0.25 inches toward the container door.
2. The cradle movement from the beginning to the end of testing was 1.25 inches at the top beam of the cradle and 0.5 inches at the base of the vertical stays.
3. No damage or excessive movement occurred with the payload or the RIBS during testing.

D. CONCLUSION. The Rapid International Standards Organization Bracing System (RIBS), as tested, is adequate to transport ammunition in intermodal side-opening containers. Additionally, the clips adequately held the vertical stays in the extended position.



Photo 6. Retainer Clip

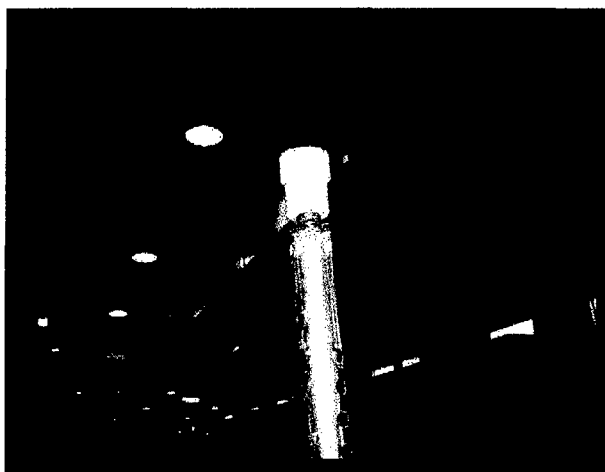

Photo 7. Installed Retainer Clip

5.2 Payload: RIBS with 155MM Separate Loading Projectiles

Gross Weight: 42,540 Pounds

Testing Date: 4 June 2002

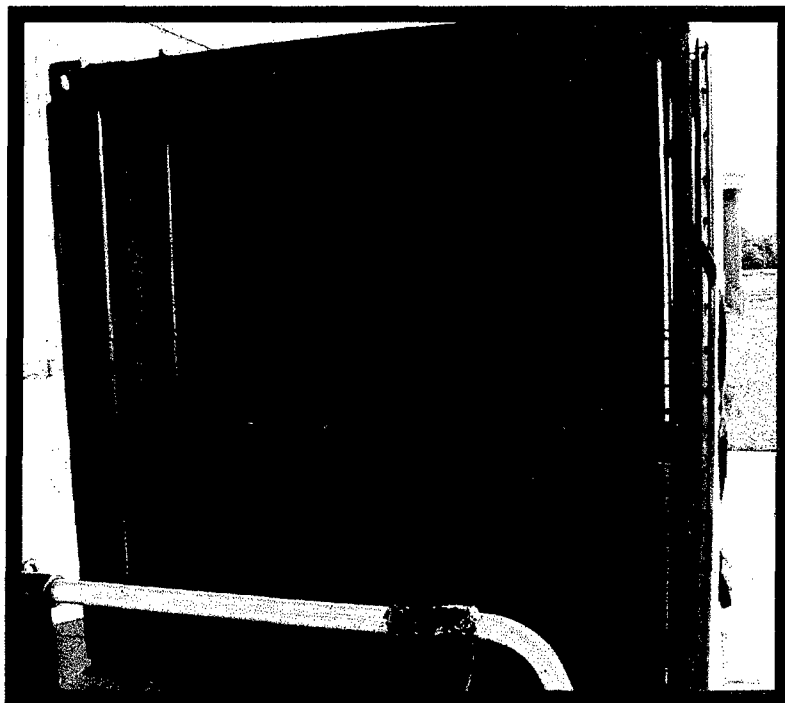

Photo 8. RIBS with 155MM Separate Loading Projectiles

A. RAIL TEST. RAIL IMPACT TEST.



Photo 9: Rail Impact Testing of the RIBS

Description	Weight
Flatcar Number: DODX 48797	62,700 lbs.
Intermodal end opening Container with 155MM SLP & RIBS	42,540 lbs.
Intermodal End Opening Container with Storage and Transport Frames	32,195 lbs.
Total Specimen Wt.	137,435 lbs.
Buffer Car (four cars)	250,000 lbs.

Figure 8.

Remarks: Figure 8 lists the test components and weights of the items used during the Rail Impact Tests. The intermodal container, with the RIBS and payload, was secured on the Container-on-Flatcar (COFC) railcar. The intermodal container, loaded with Storage and Transport Frames was used as ballast for the test.

Impact Number	Avg. Velocity (mph)
1	4.5
2	6.3
3	8.3
4	8.7

Figure 9.

Remarks:

1. Figure 9 lists the average speeds of the specimen car immediately prior to impact with the anvil. Impact #4 is the reverse impact.
2. Following Impact #2 the flange on the end of the horizontal beam moved 0.25 inches toward the closed end of the container
3. Following impact #3 the horizontal beam bowed from 0.13 inches at the corner post to 0.5 inches at the center of the closed end of the container.
4. Following Impact #3 the bottom beam at the door end of the container moved 0.75-1.0 inches. The bottom beam, which was against the payload, moved 0.5-1.5 inches. The top beam at the door end of the container moved 0.5-1.13 inches. All movement was in the direction of impact or toward the closed end of the container.
5. Following Impact #4 the beams and vertical stays at the door end failed and came out of the container upon impact. The forces imposed during impact permanently damaged the horizontal beams and vertical stays.
6. Testing was stopped due to the failure of the horizontal beams and vertical stays.



Photo 10. Damaged RIBS

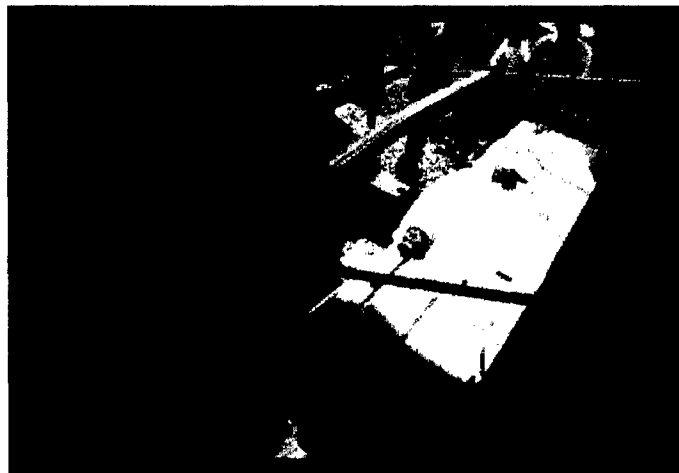

Photo 11. Damaged RIBS

B. CONCLUSION. The RIBS, as tested, is not adequate for use in intermodal end-opening containers.

5.3 Payload: RIBS with 155MM Separate Loading Projectiles

Gross Weight: 42,780 Pounds

Testing Date: 11 June 2002

Note: The beams at the door end of the container were doubled from that which was previously tested. (See 5.2).

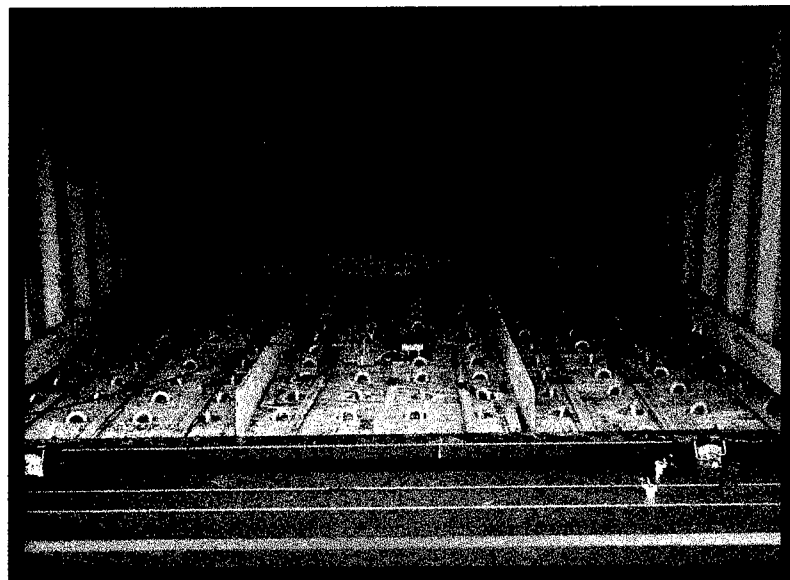

Photo 12. Doubled Horizontal Beams



Photo 13. Single Horizontal Beams (Tested 4 June 2002)

A. RAIL TEST. RAIL IMPACT TEST.



Photo 14: Rail Impact Testing of the RIBS

Description	Weight
Flatcar Number: DODX 48797	62,700 lbs.
Intermodal end- opening container with 155MM SLP & RIBS	42,660 lbs.
M1 Flatrack with MLRS Pods	28,265 lbs.
Total Specimen Wt.	133,625 lbs.
Buffer Car (four cars)	250,000 lbs.

Figure 10.

Remarks: Figure 10 lists the test components and weights of the items used during the Rail Impact Tests. The intermodal container, with the RIBS and payload, was secured on the Container-on-Flatcar (COFC) railcar. The M1 Flatrack, loaded with MLRS Pods was used as ballast for the test.

Impact Number	Avg. Velocity (mph)
1	4.6
2	6.3
3	8.4
4	8.4

Figure 11.

Remarks:

1. Figure 11 lists the average speeds of the specimen car immediately prior to impact with the anvil. Impact #4 is the reverse impact.
2. Following Impact #2 the horizontal beam deflected 0.13 inches, toward the closed end of the container, on the passenger side corner.
3. Following impact #3 the horizontal beam bowed 0.25 inches at the center of the closed end of the container. The deflection was in the direction of impact, or toward the closed end of the container.
4. Following Impact #3 the bottom beam (against the payload) moved 0.5 inches and the top beam (against the payload) moved 0.25 inches. The movement was in the direction of impact or toward the closed end of the container.
5. Following Impact #4 the beams at the door end (not against the payload) permanently deformed due to the forces imposed during testing by the horizontal stay.
6. Testing was stopped due to the permanent deformation of the horizontal beams.

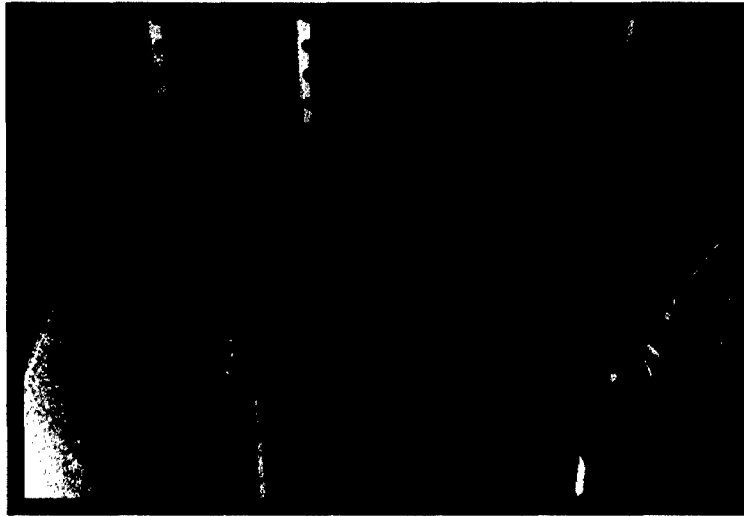

Photo 15. Deformation of RIBS



Photo 16. Deformation of RIBS

B. CONCLUSION. The RIBS, as tested, is not adequate for use in intermodal end opening containers.

5.4 Payload: RIBS with 155MM Separate Loading Projectiles

Gross Weight: 42,500 Pounds

Testing Date: 16-19 September 2002

Design changes were incorporated into the RIBS from that which was tested in June 2002. The design changes included moving the horizontal stay plates closer to the end of the beam, overlapping the horizontal stay plates on the top and bottom of the beam, closing the internal beam section, center stiffener welded in place, and widening the beam by 0.5 inches (12mm).

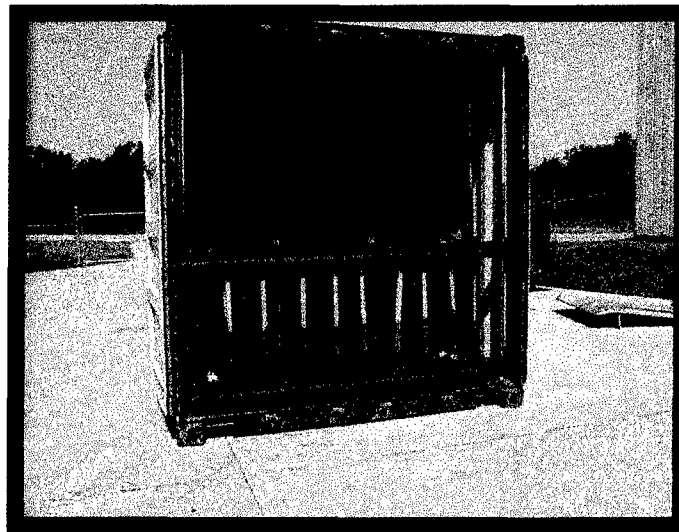

Photo 17. RIBS with 155MM Separate Loading Projectiles



Photo 18. Horizontal Stay Plate Location.

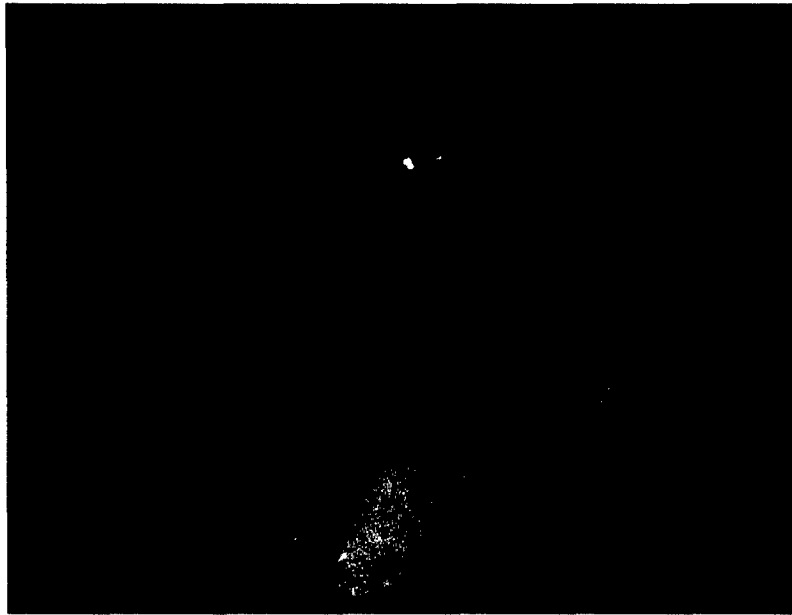

Photo 19. Horizontal Stay Overlap

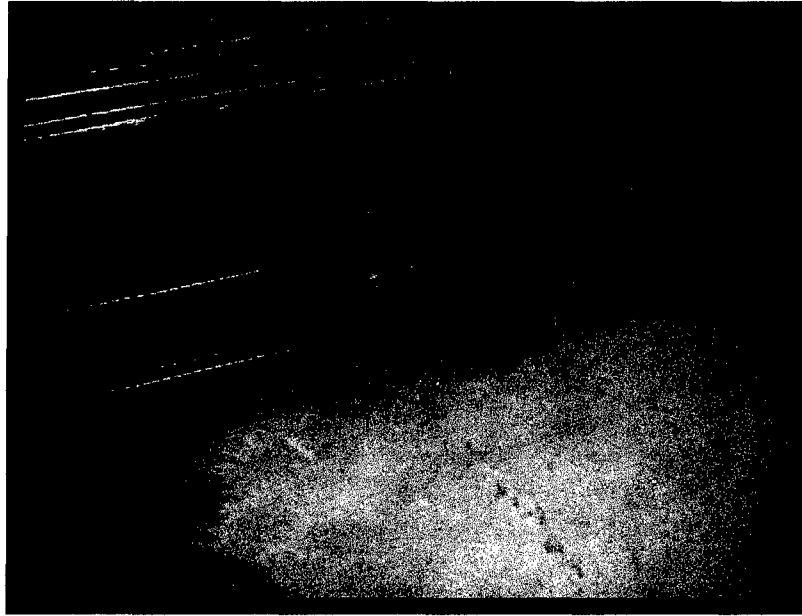

Photo 20. Center Stiffener

A. RAIL TEST. RAIL IMPACT TEST.



Photo 21: Rail Impact Testing of the RIBS

Description	Weight
Flatcar Number: DODX 48797	62,700 lbs.
Intermodal end opening container with 155MM SLP & RIBS	42,500 lbs.
M1 Flatrack with MLRS Pods	28,265 lbs.
Total Specimen Wt.	133,465 lbs.
Buffer Car (four cars)	250,000 lbs.

Figure 12.

Remarks: Figure 12 lists the test components and weights of the items used during the Rail Impact Tests. The intermodal container, with the RIBS and payload, was secured on the Container-on-Flatcar (COFC) railcar. The M1 Flatrack, loaded with MLRS Pods was used as ballast for the test.

Impact Number	Avg. Velocity (mph)
1	4.6
2	5.9
3	6.1
4	8.3
5	8.4

Figure 13.

Remarks:

1. Figure 13 lists the average speeds of the specimen car immediately prior to impact with the anvil. Impact #5 is the reverse impact.
2. Impact #2 was determined to be a "no test" due to the impact speed was less than 6.0 mph. The test was repeated.
3. Following Impact #4 the bottom beams on the first row (at the door) moved 0.25 inches toward the closed end of the container. The bottom beam in the

second row (against the payload) moved 0.5 inches toward the closed end of the container or the direction of impact.

4. The top beam at the closed end of the container deflected, toward the closed end of the container, 0.13 inches in the center.

5. Following Impact #5 the beams at the door end of the container moved back to the original starting position.

6. No damage or excessive movement occurred with the payload or the RIBS during testing.

B. ON/OFF ROAD TESTS.

1. HAZARD COURSE.

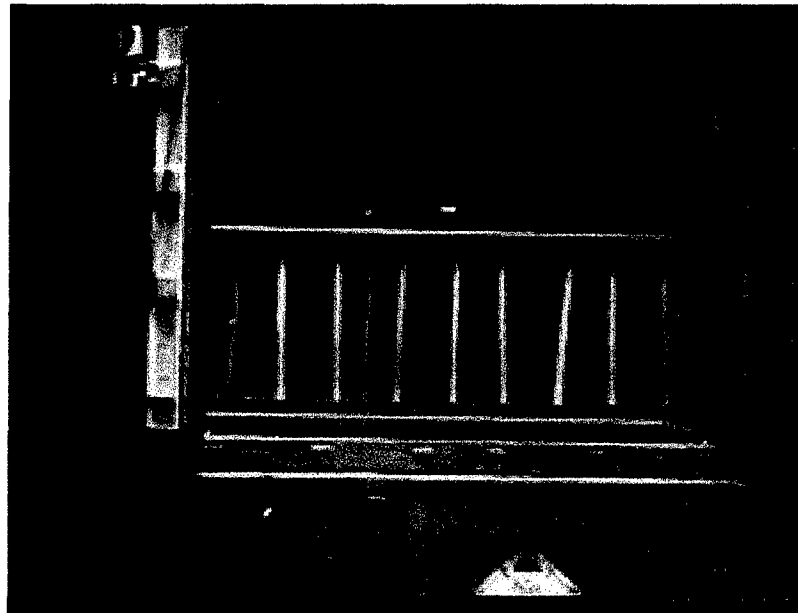

Photo 22: Hazard Course Testing of the RIBS

Pass No.	Elapsed Time	Avg. Velocity (mph)
1	26Seconds	5.8
2	26 Seconds	5.8

Figure 14.

Remarks:

1. Figure 14 lists the average speeds of the test load through the Hazard Course.
2. Inspection following Pass #1 revealed that the vertical stays had moved down from the original starting position.
3. No damage or excessive movement occurred with the payload or the RIBS during Passes #1 and #2.

2. **ROAD TRIP:** No damage or excessive movement occurred with the payload or the RIBS.

3. **PANIC STOPS:** Testing was not required due to the RIBS had been rail impact tested.

4. **HAZARD COURSE.**

Pass No.	Elapsed Time	Avg. Velocity (mph)
3	26 Seconds	5.8
4	27 Seconds	5.6

Figure 15

Remarks:

1. Figure 15 lists the average speeds of the test load through the Hazard Course Passes #3 and #4.
2. Inspection following each Hazard Course Pass (Passes #1- #4) and the Road

Trip revealed that the vertical stays had moved down from the original starting position. The total movement ranged from 0.5 inches to 2.75 inches. Therefore, the clips that were used and prevented the stay movement during the June 2002 testing are required.

3. No damage or excessive movement occurred with the payload or the RIBS during Passes #3 and #4.

5. WASHBOARD COURSE:

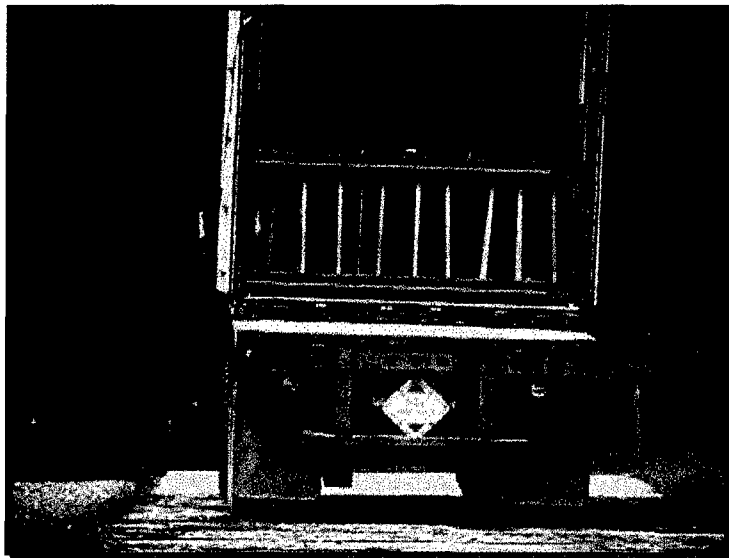

Photo 23. Washboard Course Testing of the RIBS

Remarks: No damage or excessive movement occurred with the payload or the RIBS during testing.

C. OCEAN-GOING VESSEL TEST. SHIPBOARD TRANSPORTATION SIMULATOR (STS) TEST METHOD.

Remarks: No damage or excessive movement occurred with the payload or the RIBS during testing.

D. CONCLUSION. The RIBS, as tested, is adequate to transport ammunition in intermodal end opening containers. The clips that were used during the June 2002 are required to prevent the vertical stays from moving down.

PART 6 – ACCELEROMETER DATA

The accelerometers were located on the test specimen. The location of the accelerometers is shown in the photos. Also following are the graphic depictions of each of the railcar impacts, hazard course, road course, and washboard course. The axial orientation of the accelerometers is as follows:

r - resultant vector x – longitudinal y –lateral z – vertical

A table depicting the identification and location of the graphic illustrations is below:

RIBS	
RIBS WITH MK-84 IN SIDE OPENING CONTAINER	PAGE
Rail Impact	No data
Hazard Course – Pass #1	6-2
Hazard Course – Pass #2	6-2
Hazard Course – Pass #3	6-3
Hazard Course – Pass #4	6-3
Road Trip	No data
Washboard Course	6-4
RIBS WITH 155MM SLP IN END OPENING CONTAINER	PAGE
Rail Impact	6-5
Hazard Course Pass #1	6-6
Hazard Course Pass #2	6-6
Hazard Course Pass #3	No data
Hazard Course Pass #4	No data
Road Trip	6-7
Washboard Course	No data

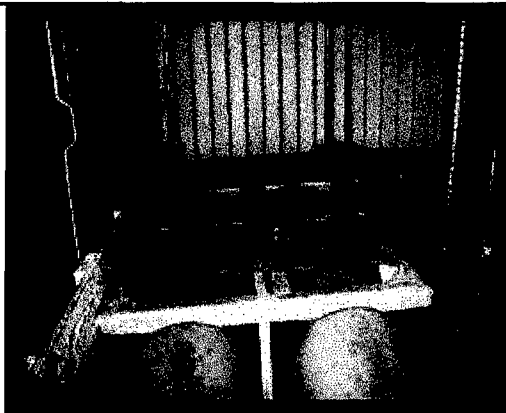

**Sensor Location for the MK-84,
2000-Pound Bomb RIBS Testing**

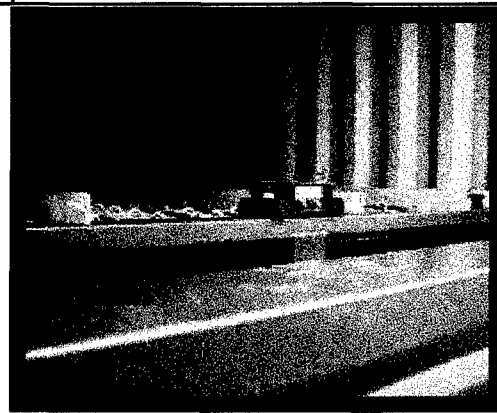

Sensor Location for the 155MM SLP

Multiple Wave View: RIBS with MK-84 Road Hazard 1st and 2nd pass EDR3 #0185 Acceleration

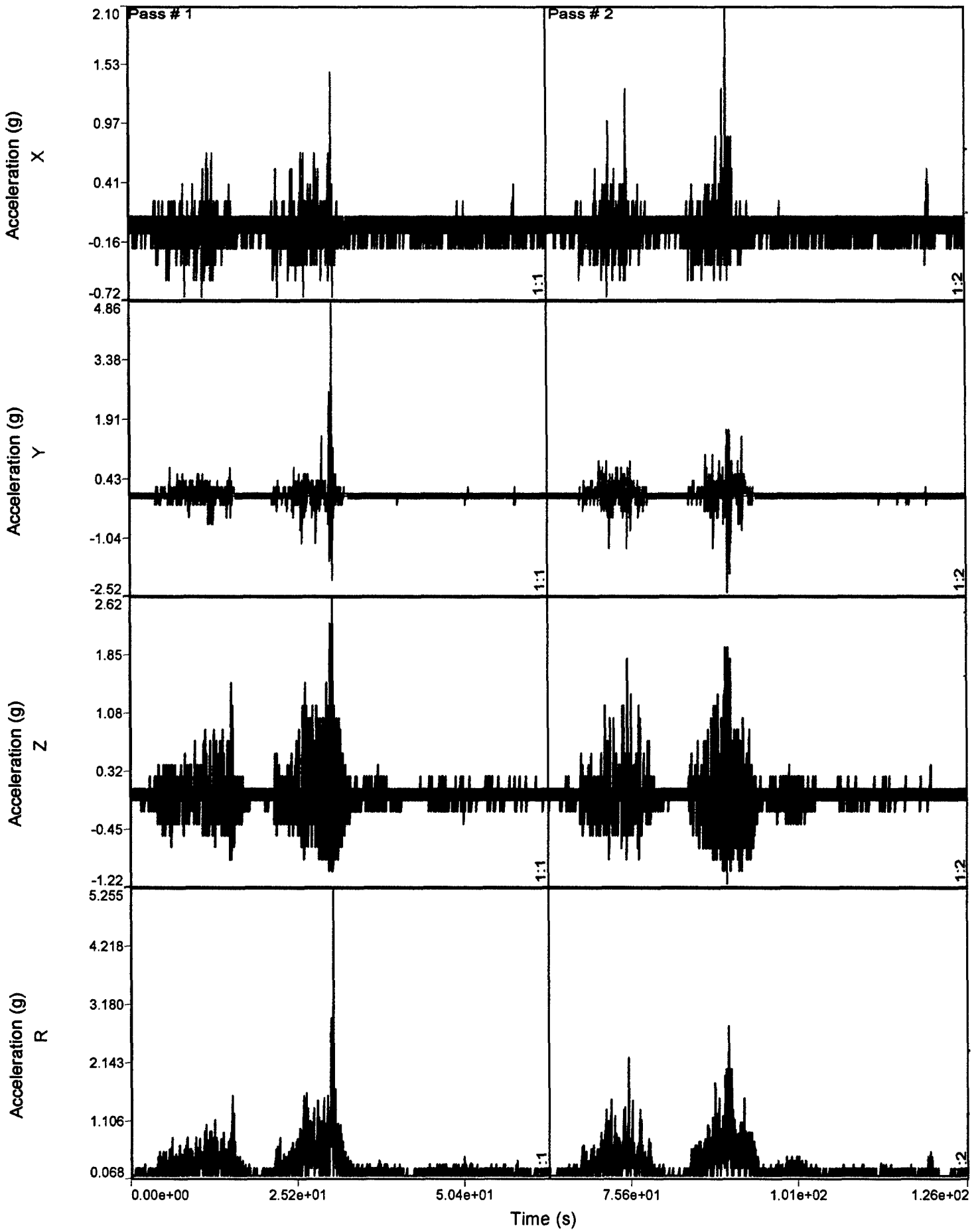

Testing Date: 4-7 June 2002

Multiple Wave View: RIBS with MK-84 Road Hazard 3 and 4 EDR3 #0185 Acceleration

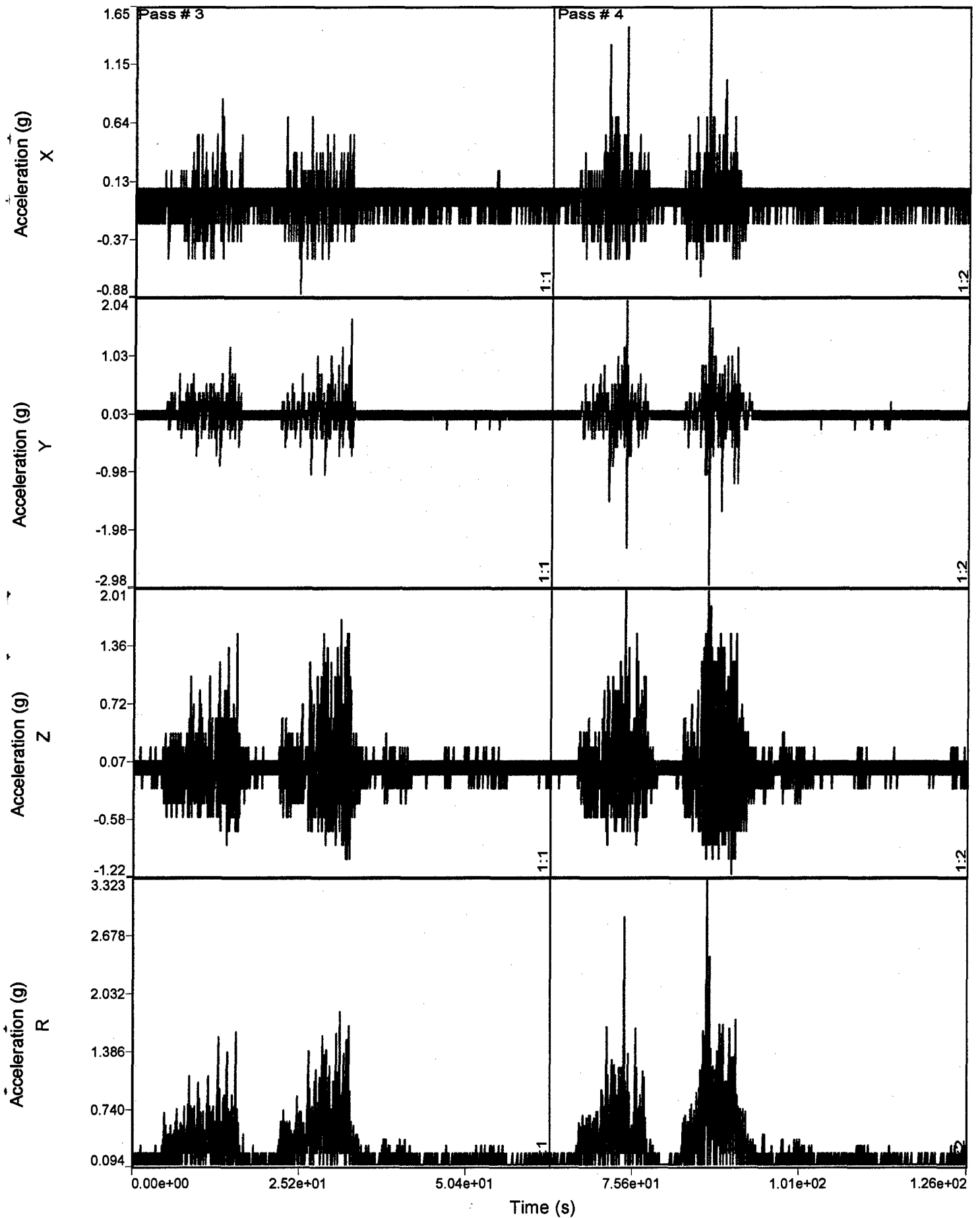

Testing Date: 4-7 June 2002

Multiple Wave View: RIBS with MK-84 Washboard EDR3 #0185 Acceleration

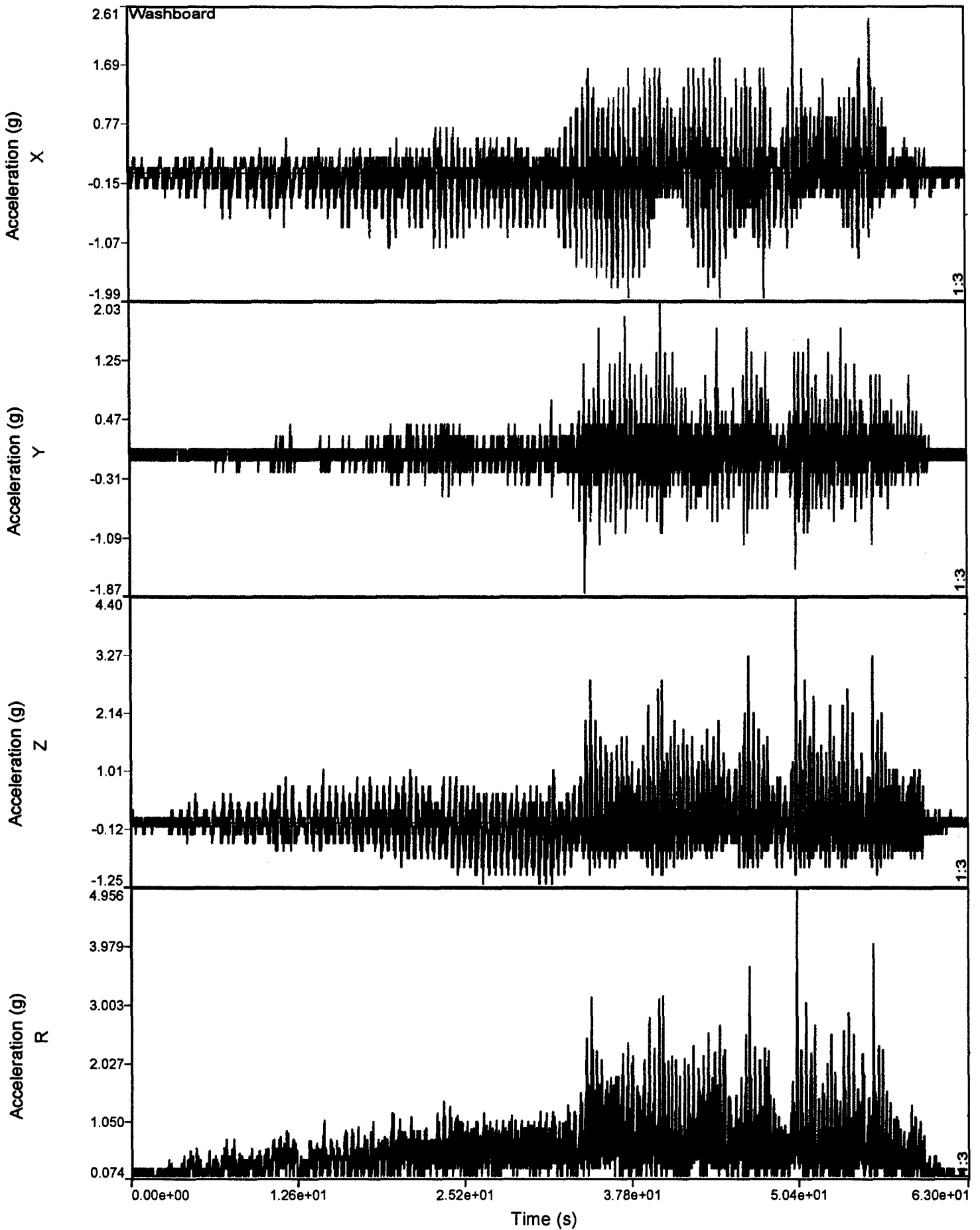

Testing Date: 4-7 June 2002

Multiple Wave View:RIBS with 155SLP Rail Impact Testing EDR3 #0186 Acceleration

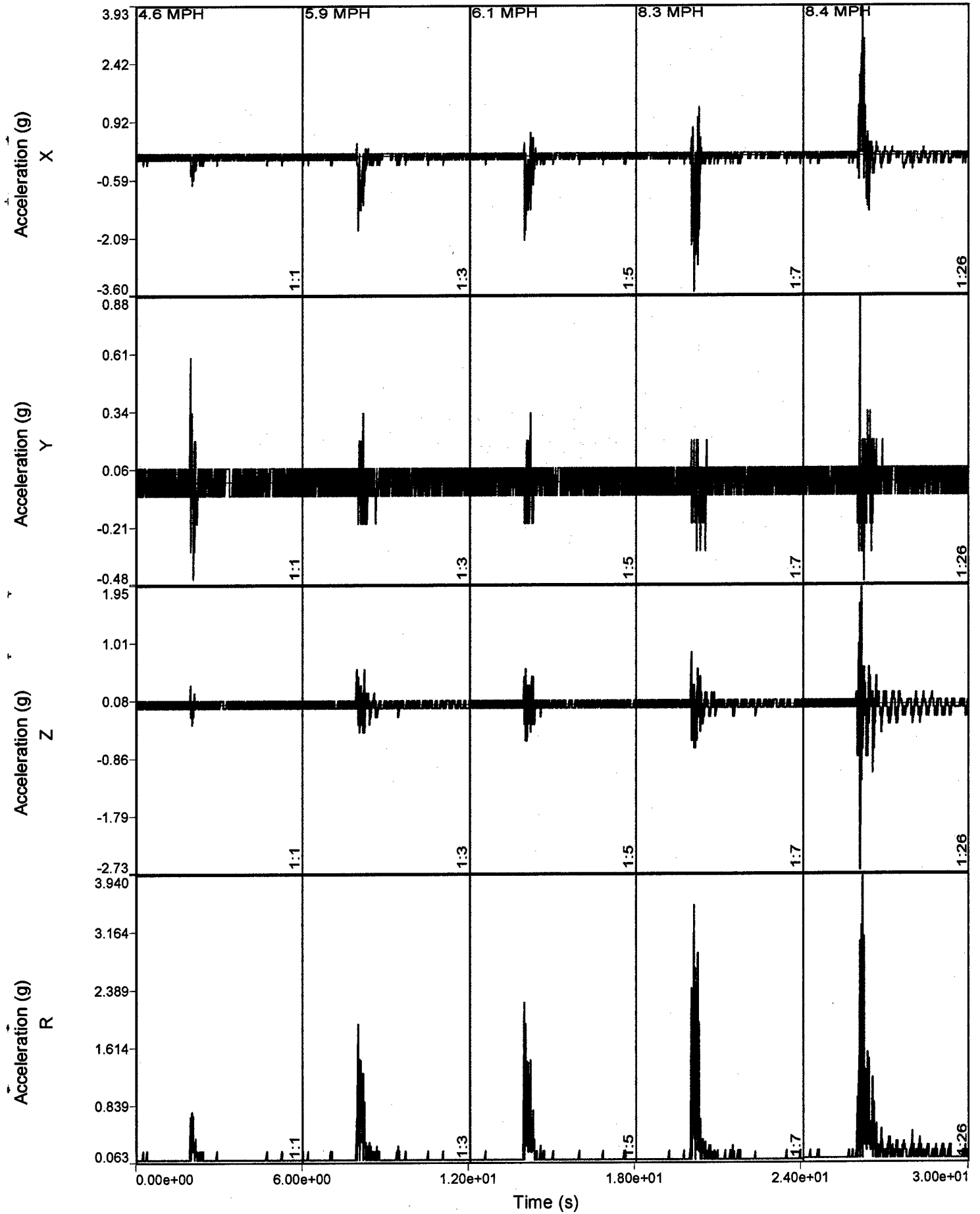

Testing Date:16-19 September 2002

Multiple Wave View: RIBS with 155 SLP Hazard Passes 1 and 2 EDR3 #0186 Acceleration

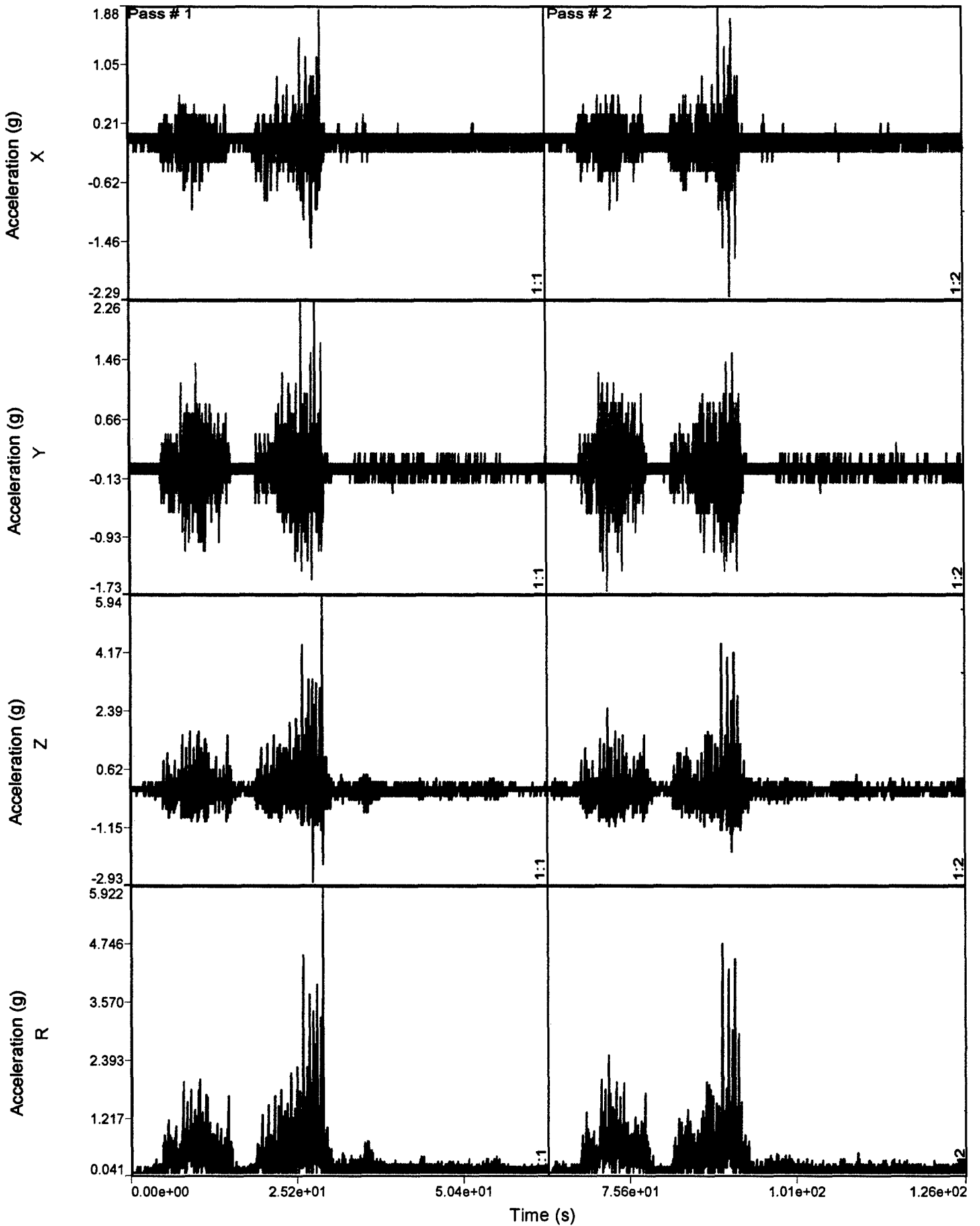

Testing Date: 16-19 September 2002

Multiple Wave View: RIBS with 155 SLP 30 Mile Road Course EDR3 #0186 Acceleration

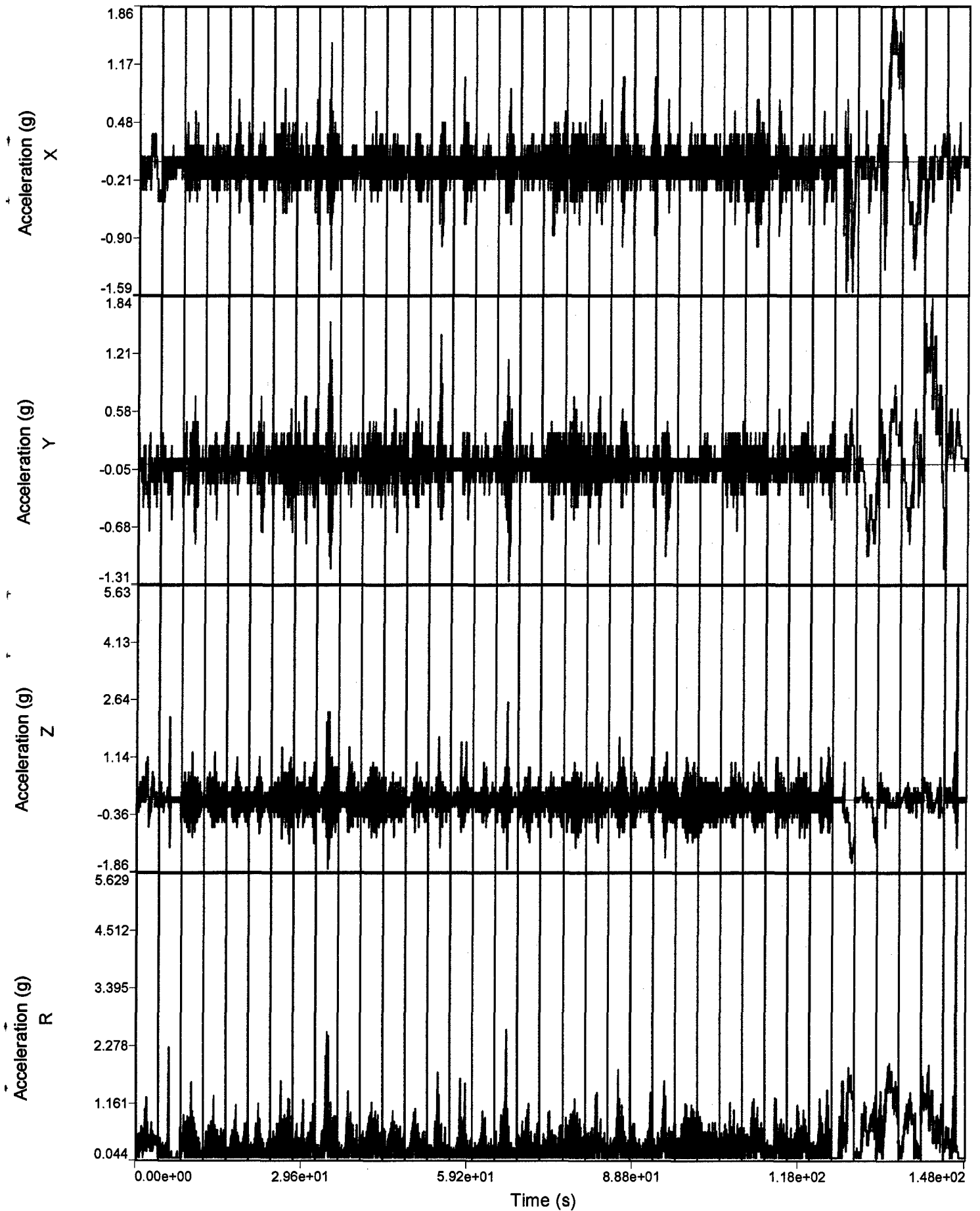

Testing Date: 16-19 September 2002

PART 7 – DRAWINGS

AMC Drawings 19-48-7127 and 19-48-4155 were used as guidelines for securing the munitions in end-opening and side-opening containers, as stated in Part 1. The drawings can be accessed at.

<http://www/dac.army.mil/dapam/toc.html>

The following drawings represent the load configuration that was subjected to the test criteria.

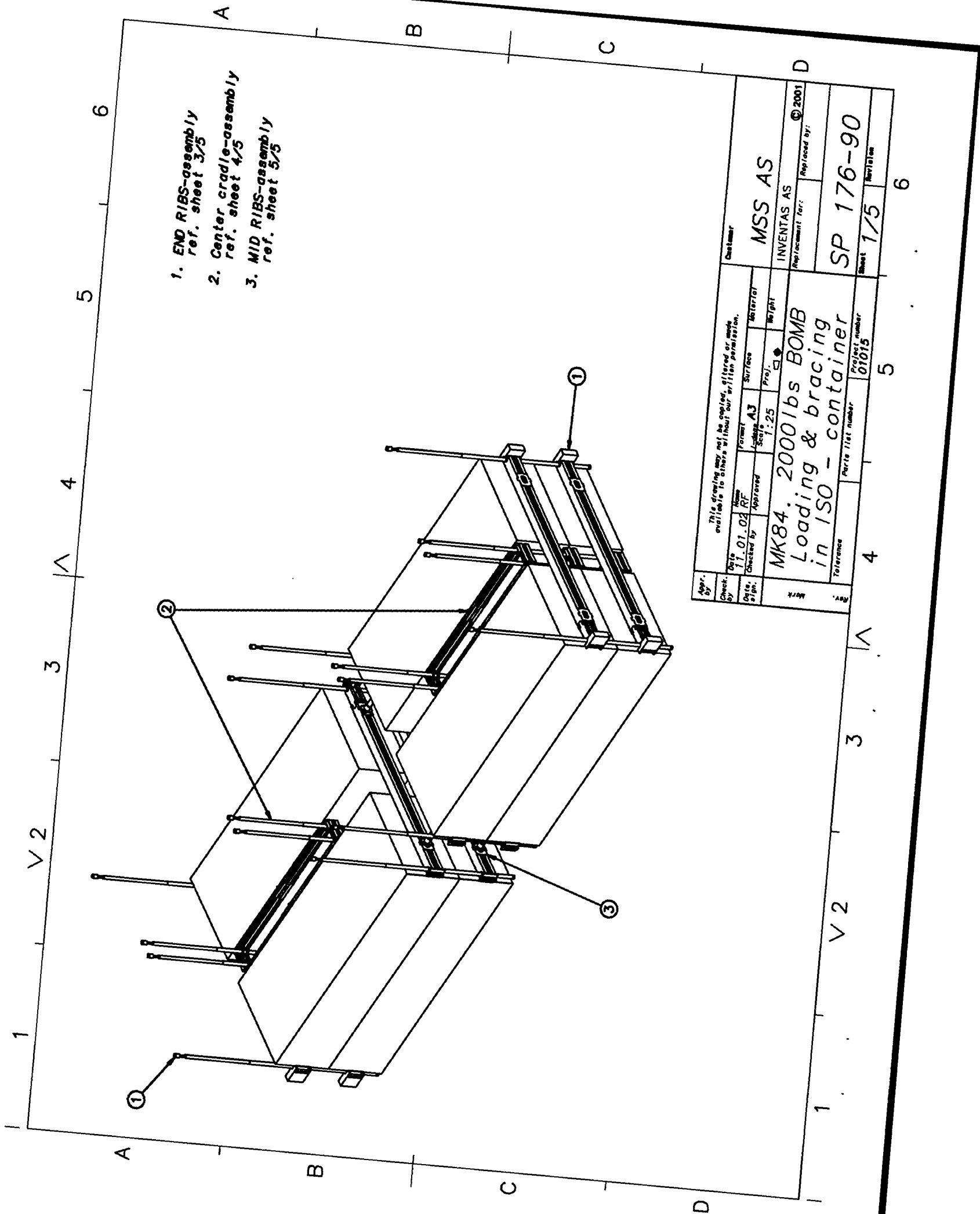

Appr. by	This drawing may not be copied, altered or made available to others without our written permission.				Customer
Check. by	Date: 11-01-02	Form: A3	Surface	Material	MSS AS
Date, sign.	Checked by: RF	Scale: 1:25	Proj.	Weight	INVENTAS AS
Rev.	MK84, 2000lbs BOMB Loading & bracing in ISO - container			Project number: 01015	Replacement for: © 2001
	Tolerance		Parts list number	Sheet 1/5	Revision
	1	3	4	5	6

1 2 3 4 5 6

A

B

C

D

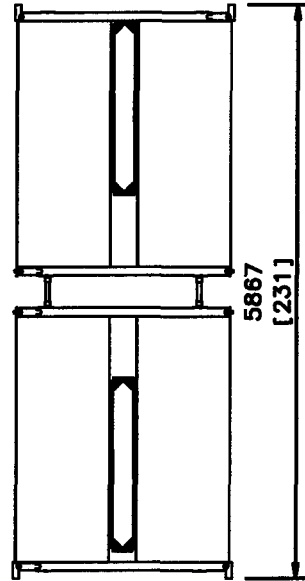
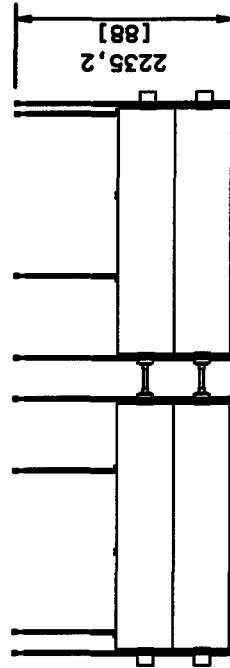
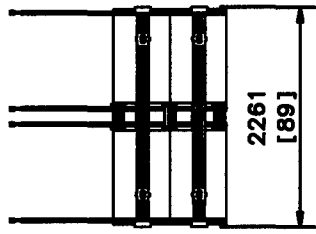

DIMENSIONS mm [INCH]

Appr. by:	This drawing may not be copied, altered or made available to others without our written permission.				Customer:	MSS AS
Check. by:	Date:	Drawn by:	Format:	Surface:	Material:	
	01.01.02	RP	A3			
Date: 01/01/02	Checked by:	Approved:	Scale:	Proj.:	Weight:	
			1:50			
Rev.:	MK84, 2000lbs BOMB Loading & bracing in ISO - container				Replacement for:	INVENTAS AS © 2001
	Tolerance				Project number:	SP 176-90
	Parts list number:				Revision:	2/5
	01015					6

1 2 3 4 5 6

1 2 3 4 5 6

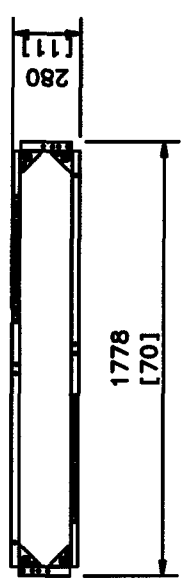
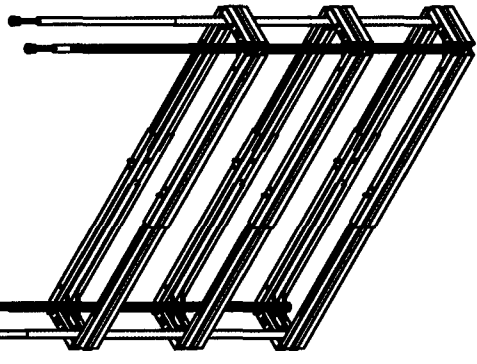
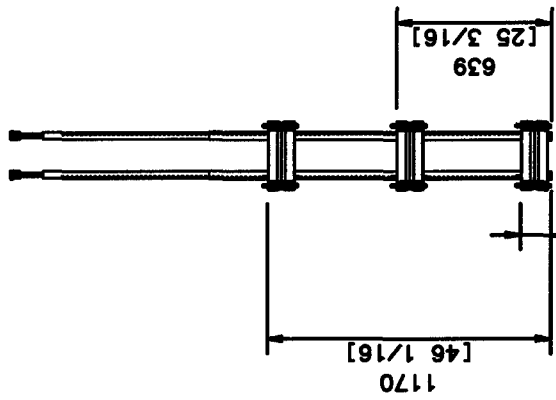
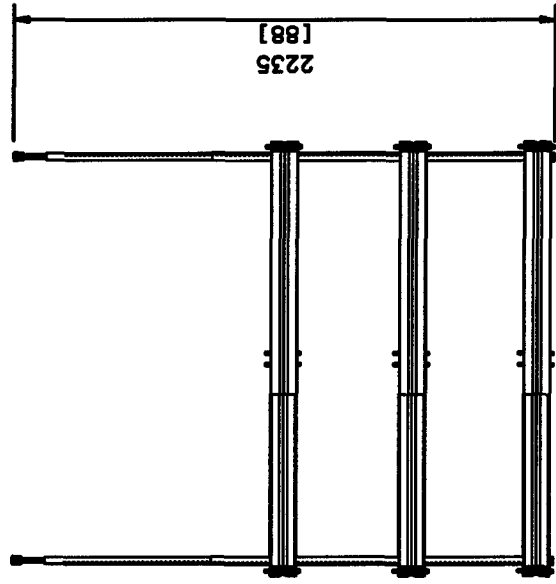

DIMENSIONS mm [INCH]

Appr. by	This drawing may not be copied, altered or made available to others without our written permission.				Customer
Check by	Date	Rev.	Format	Surface	Material
	15.11.01	RP	A3		MSS AS
Date	Checked by	Approved	Scale	Proj.	Weight
			1:20		KG
MK84, 2000lbs BOMB Center cradle					
Rev.	Work	Parts list number	Project number	Sheet	Revision
		01015	01015	4/5	6
				Replacement for:	Replaced by:
				INVENTAS AS	© 2001
				SP176-90	

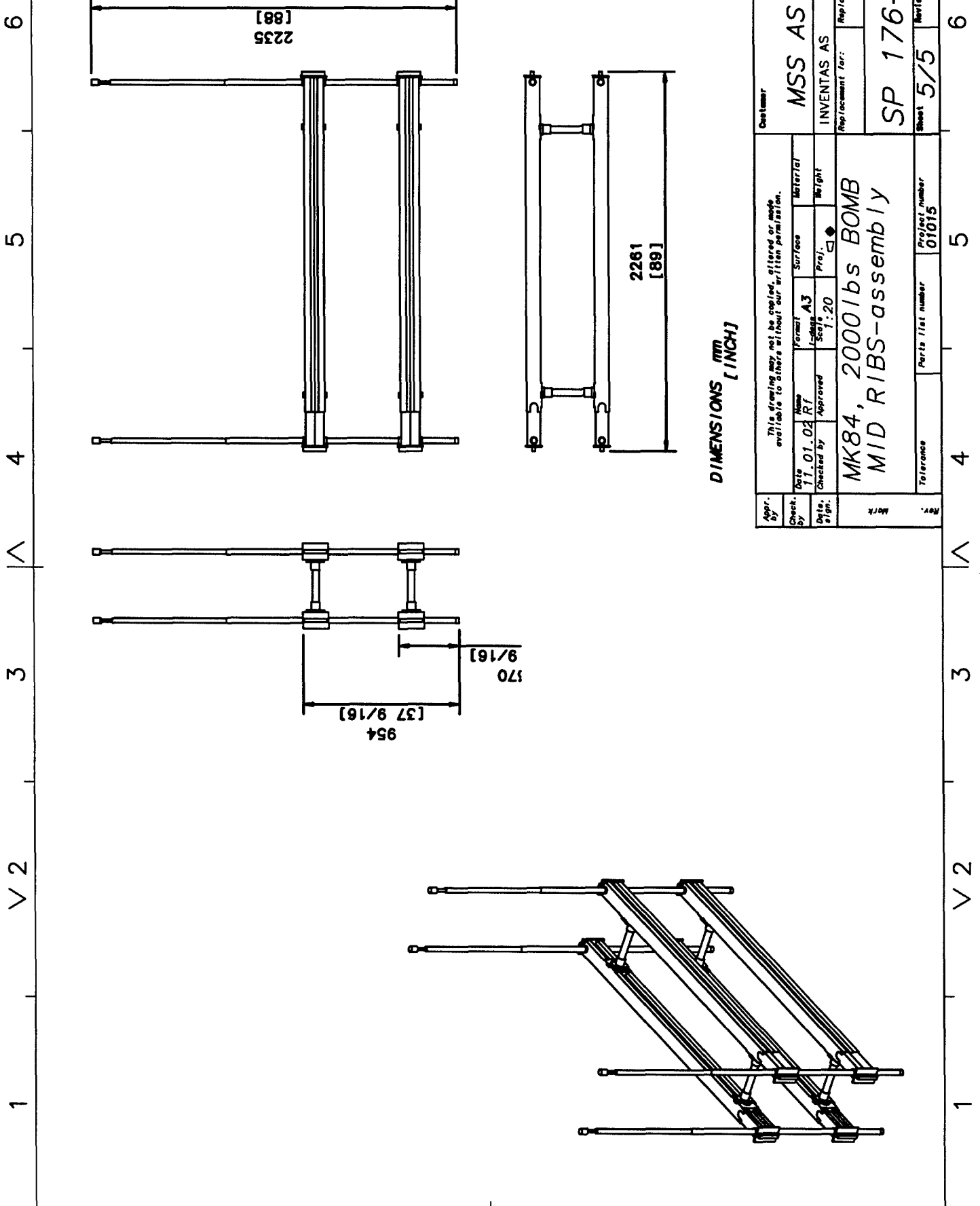

DIMENSIONS mm [INCH]

Appr. by:	This drawing may not be copied, altered or made available to others without our written permission.				Customer:	MSS AS	
Check. by:	Date:	Name:	Form:	Surface:	Material:		
	11 01 02	RT	A3				
Date sign.:	Checked by:	Approved:	Scale:	Proj.:	Weight:		
			1:20				
Rev. Mark:	MK84, 2000 lbs BOMB MID RIBS-assembly					Replacement for:	INVENTAS AS © 2001
	Tolerance:	Parts list number:	Project number:	Sheet:	Revision:		
		01015	01015	5/5			

1 2 3 4 5 6

A

B

C

D

1. REAR RIBS-assembly
ref. sheet 3/4
2. FRONT RIBS-assembly
ref. sheet 4/4

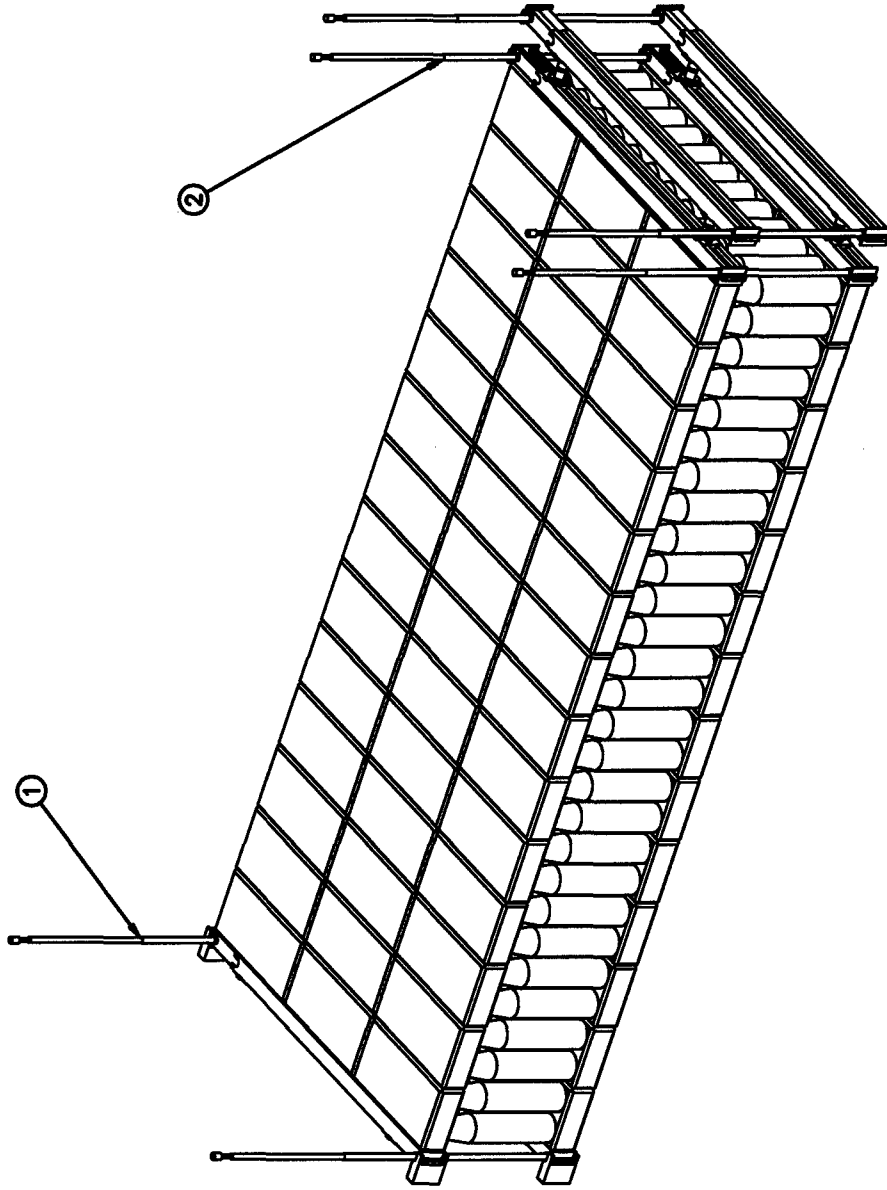

A

B

C

D

1 2 3 4 5 6

Appr. by	This drawing may not be copied, altered or made available to others without our written permission.				Customer
Check. By	Date	Rev.	Format	Surface	MSS AS
15.05.02	RP	A3	1:25	Prof.	INVENTAS AS © 2001
Checked by	Approved	Scale	Prof.	Weight	Replacement for:
					Replaced by:
155mm, 8/large wooden pallet, in End-open. ISO-cont.					CA 176-80
Mark	Tolerance	Parts list number	Project number	Sheet	Revision
			01015	1/4	6

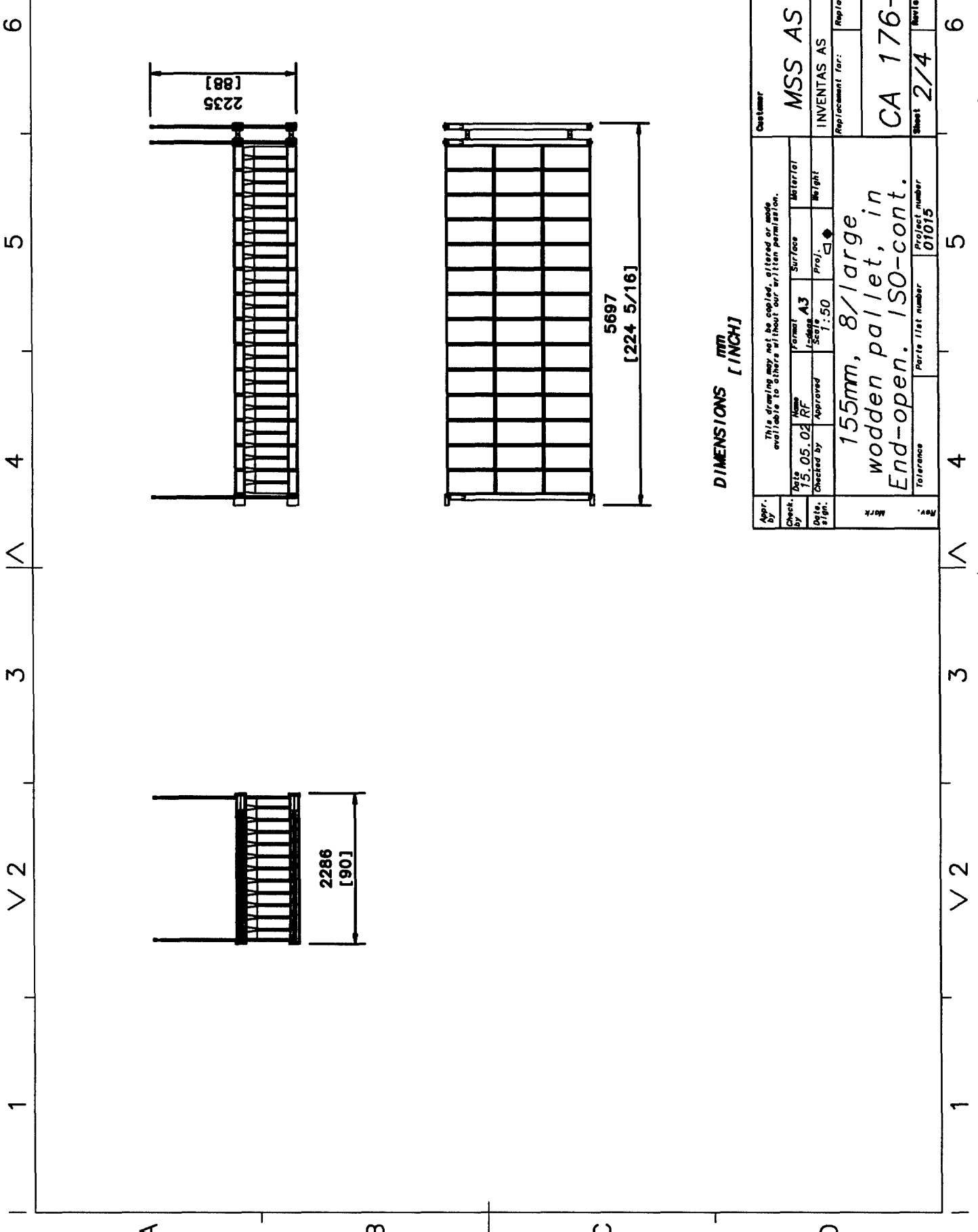

DIMENSIONS mm [INCH]

Appr. by:	This drawing may not be copied, altered or made available to others without our written permission.				Customer
Check. by:	Date:	Name:	Format:	Surface:	MATERIAL
	15.05.03	RF	A3		MSS AS
Date. sign.	Checked by:	Approved:	Scale:	Proj.:	Weight:
			1:50		
Mark:	155mm, 8/large wooden pallet, in End-open. ISO-cont.				Replacement for:
	Tolerance:	Partic list number:	Project number:	Replacement by:	
			01015	© 2001	
				Sheet	Revision
				2/4	CA 176-80

1 2 3 4 5 6

V 2

1 2 3 4 5 6

V 2

1 2 3 4 5 6

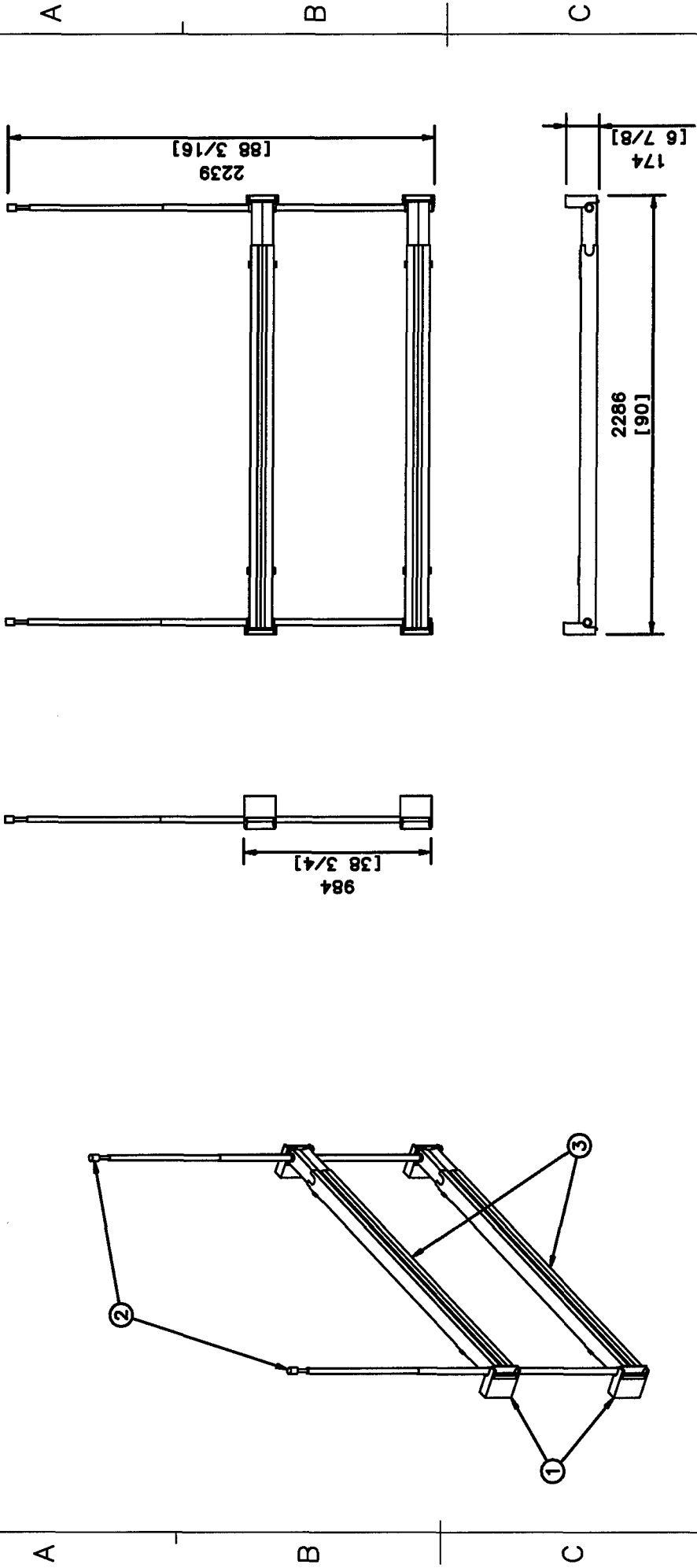

Pos.no.	Part Name	Quantity
1.	RIBS Corner Cushion ref. 01015_A080	4
2.	RIBS Vertical stay ref. 01015_A020	2
3.	RIBS Bar ref. 01015_A010	2

Appr. by	This drawing may not be copied, altered or made available to others without our written permission.				Customer
Check. by	Date	Rev.	Format	Surface	Material
15.05.02	RT	A3			MSS AS
Checked by	Approved	Scale	Proj.	Weight	
		1:20			
Date sign.	155mm, 8/large wooden pallet, in End-open. ISO-cont.				INVENTAS AS © 2001
Mark					Replaced by:
					CA 176-80
Rev.					Sheet 3/4
					Revision
					6

1 2 3 4 5 6

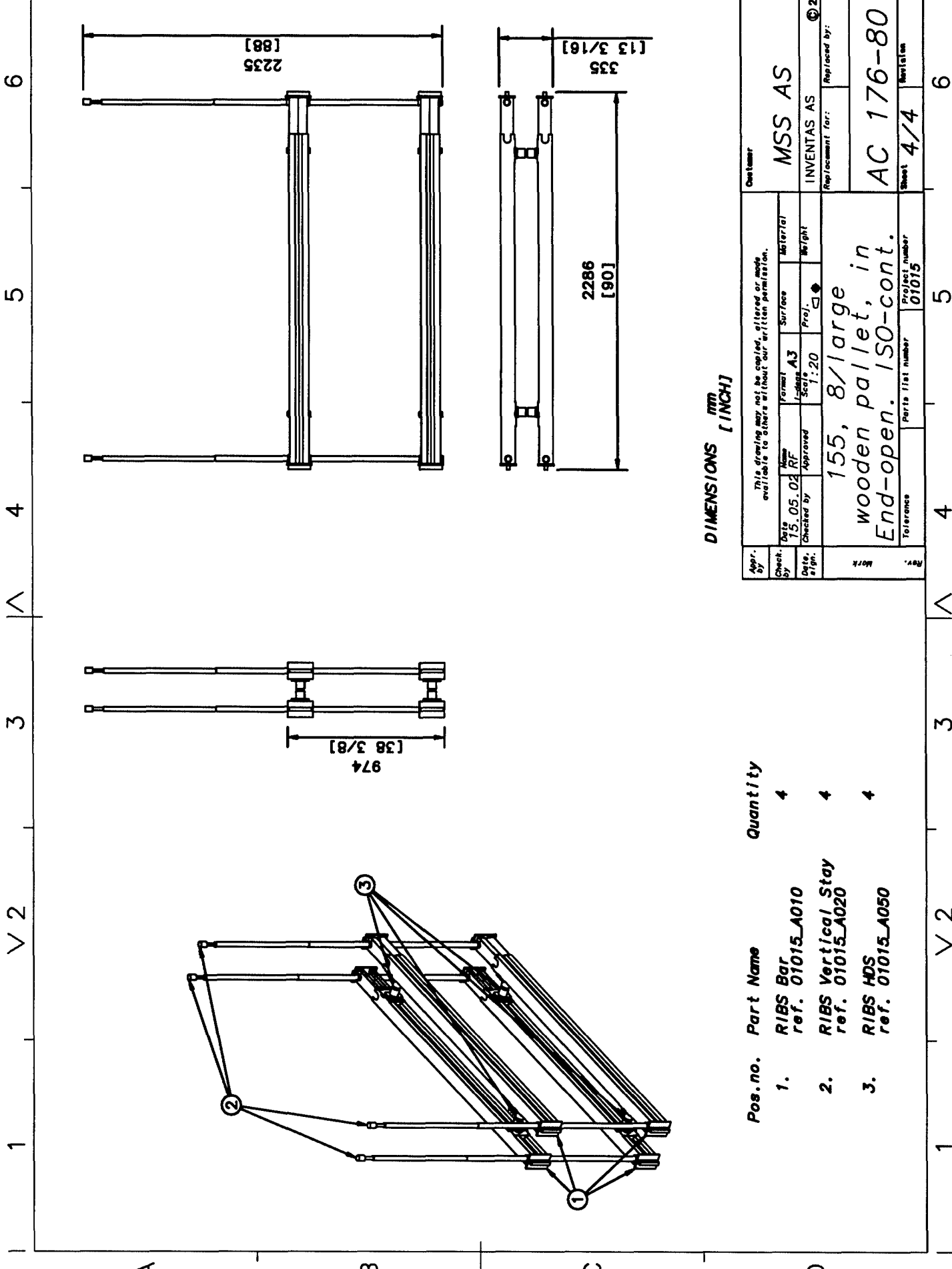

DIMENSIONS mm [INCH]

Appr. by:	This drawing may not be copied, altered or made available to others without our written permission.				Customer:	MSS AS
Check. by:	Date:	Material:	Surface:	Weight:	Replacement for:	INVENTAS AS
15.05.03	RF	Format:	A3	Scale:	1:20	© 2001
Checked by:	Approved:	Proj.:	□	□	Replaced by:	
155, 8/1 large wooden pallet, in End-open. ISO-cont.						
Work	Tolerance:	Parts list number:	Project number:	01015	Sheet:	4/4
					Revision:	6

Pos. no.	Part Name	Quantity
1.	RIBS Bar ref. 01015_A010	4
2.	RIBS Vertical Stay ref. 01015_A020	4
3.	RIBS HDS ref. 01015_A050	4

V 2

1 2 3

4 5 6

A B C D