

AD \_\_\_\_\_

Award Number: DAMD17-98-1-8325

TITLE: Cell Migration as a Therapeutic Target in Malignant  
Breast Cancer

PRINCIPAL INVESTIGATOR: George E. Plopper, Jr., Ph.D.

CONTRACTING ORGANIZATION: University of Nevada, Las Vegas  
Las Vegas, Nevada 89154-1037

REPORT DATE: September 2002

TYPE OF REPORT: Annual Summary

PREPARED FOR: U.S. Army Medical Research and Materiel Command  
Fort Detrick, Maryland 21702-5012

DISTRIBUTION STATEMENT: Approved for Public Release;  
Distribution Unlimited

The views, opinions and/or findings contained in this report are those of the author(s) and should not be construed as an official Department of the Army position, policy or decision unless so designated by other documentation.

**REPORT DOCUMENTATION PAGE**Form Approved  
OMB No. 074-0188

Public reporting burden for this collection of information is estimated to average 1 hour per response, including the time for reviewing instructions, searching existing data sources, gathering and maintaining the data needed, and completing and reviewing this collection of information. Send comments regarding this burden estimate or any other aspect of this collection of information, including suggestions for reducing this burden to Washington Headquarters Services, Directorate for Information Operations and Reports, 1215 Jefferson Davis Highway, Suite 1204, Arlington, VA 22202-4302, and to the Office of Management and Budget, Paperwork Reduction Project (0704-0188), Washington, DC 20503

1. AGENCY USE ONLY (Leave blank)	2. REPORT DATE September 2002	3. REPORT TYPE AND DATES COVERED Annual Summary (1 Sep 98 -31 Aug 02)
----------------------------------	----------------------------------	--

4. TITLE AND SUBTITLE Cell Migration as a Therapeutic Target in Malignant Breast Cancer	5. FUNDING NUMBERS DAMD17-98-1-8325
--	--

6. AUTHOR(S) George E. Plopper, Jr., Ph.D.
---

7. PERFORMING ORGANIZATION NAME(S) AND ADDRESS(ES) University of Nevada, Las Vegas Las Vegas, Nevada 89154-1037  E-Mail: ploppg@rpi.edu	8. PERFORMING ORGANIZATION REPORT NUMBER
---	--

9. SPONSORING / MONITORING AGENCY NAME(S) AND ADDRESS(ES) U.S. Army Medical Research and Materiel Command Fort Detrick, Maryland 21702-5012	10. SPONSORING / MONITORING AGENCY REPORT NUMBER
---	--

20030122 104

11. SUPPLEMENTARY NOTES report contains color
--

12a. DISTRIBUTION / AVAILABILITY STATEMENT Approved for Public Release; Distribution Unlimited	12b. DISTRIBUTION CODE
---	------------------------

13. ABSTRACT (*Maximum 200 Words*)

The objects of this project are to develop a high-throughput method for screening potential inhibitors of breast cancer cell migration, and to apply this method to identify signaling events mediating constitutive migration of malignant breast cells. The pathways that control these signaling events may be targets for development of new classes of anti-tumor drugs. The significant advances made during this project include (1) development of an efficient, high-throughput migration assay compatible with drug screening; (2) identification of three molecules that are involved in integrin-mediated cell signaling and migration (RACK1, Focal Adhesion Kinase, and Ca<sup>2+</sup>); (3) development of a model system for examining integrin-specific signaling in breast cells adhering to laminin-1; and (4) the identification of perillyl alcohol as a non-cytotoxic inhibitor of breast cell migration. The significance of this work is demonstration of the utility of the novel migration inhibitor drug screen we have developed, plus development of reagents that will enable us to examine the signaling associated with specific integrin complexes in breast cells.

14. SUBJECT TERMS integrins, laminins, extracellular matrix, migration, drug screening, breast cancer	15. NUMBER OF PAGES 139
	16. PRICE CODE

17. SECURITY CLASSIFICATION OF REPORT Unclassified	18. SECURITY CLASSIFICATION OF THIS PAGE Unclassified	19. SECURITY CLASSIFICATION OF ABSTRACT Unclassified	20. LIMITATION OF ABSTRACT Unlimited
---	--	---	---

## Table of Contents

Cover.....	1
SF 298.....	2
Table of Contents.....	3
Introduction.....	4
Body.....	4
Key Research Accomplishments.....	6
Reportable Outcomes.....	6
Conclusions.....	10
References.....	10
Appendices.....	11

## Introduction

The purpose of this project is to identify the mechanisms governing the constitutive migration of breast cancer cells, with an eye towards reducing the severity of malignant breast cancer by inhibiting the signaling pathways responsible for maintaining this migration. The approaches proposed in this project focus on developing an in vitro migration assay suitable for identifying new biochemical inhibitors of tumor cell migration, and to characterize the mechanism of action of cell migration inhibitors. We have successfully employed this approach to identify perillyl alcohol as a non-cytotoxic inhibitor of breast cell migration.

## Body

The revised Statement of Work lists five tasks. The accomplishments for these tasks are as follows:

Task 1. Optimize assays for identifying signaling proteins in migrating cells, Months 1-12.

- a. Select materials and format for automated migration assay.
- b. Develop and optimize sensitivity and throughput of non-fluorescence, dye-based assay.
- c. Apply assay to characterize known anti-tumor drugs.

This task was completed and the results are described in the abstracts:

Rust, W.L., J.L. Huff, and G.E. Plopper. A high-throughput assay for screening anti-migratory compounds. *Molecular Biology of the Cell* 10:267a, 1999. This was attached to the 2000 Annual Report.

Wagner, J.E., C. DiGennaro, J.A. Elegbede, W. Rust, and G.E. Plopper. Application of an automated, high-throughput assay to identify perillyl alcohol as a non-cytotoxic inhibitor of breast cancer migration. *Molecular Biology of the Cell* 10:262a, 1999.

And in the manuscript:

Rust, W.L., J.L. Huff, and G.E. Plopper. Screening assay for pro/anti-migratory compounds. *Analytical Biochemistry*, 280:11-19, 2000. This manuscript is attached at the end of this report.

Task 2. Identify integrin-associated signaling events controlling breast cell migration on laminins, Months 13-36.

- a. Apply  $\text{Ca}^{+2}$  signaling assays to normal and malignant breast cells on laminin-1 and -5.

This has been accomplished and the data is presented in Figure 1. We found that cytoplasmic  $\text{Ca}^{+2}$  levels vary in human breast cells plated on different extracellular matrix proteins. Coupled with our finding that the calcium chelating dye calcein and the calcium channel inhibiting drug carboxyimidotrizole interferes with breast cell migration (Rust et al, *Analytical Biochemistry*, 2000), we conclude that calcium signaling is a critical component of migration signaling on laminins.

- b. Apply cAMP signaling assays to normal cells plated on laminin-5 in the presence or absence of integrin-stimulating antibody.
- c. Identify pertussis toxin-sensitive proteins in migrating normal breast cells plated on laminin-5.

This work was accomplished and was published as:

Plopper, G.E., J.L. Huff, W.L. Rust, M.A. Schwartz, and V. Quaranta. Antibody induced activation of  $\beta 1$  integrin receptors stimulates cAMP-dependent migration of breast cells on laminin-5. *Molecular Cell Biology Research Communications*, 4:129-135, 2000. This manuscript is attached to the end of this report.

We also completed a study of the G protein subunit RACK1 on cell migration, which was published as:

Buensuceso, C.S., D. Woodside, J.L.Huff, G.E. Plopper, and T.E. O'Toole. The WD protein Rack1 mediates PKC and integrin dependent cell migration. *Journal of Cell Science*, 114:1691-1698, 2001. This manuscript is attached to the end of this report.

Task 3. Identify inhibitory compounds that block migration of malignant breast cells on fibronectin, Months 12-36.

- a. Optimize sensitivity and throughput of fluorescence-based cell migration assay.
- b. Screen inhibitors of biochemical signalling pathways in migration assays.
- c. Determine mechanism of action of inhibitors at protein/second messenger level.

This work was completed and is reported in:

Wagner, J.E. , Huff, J.L., Rust W.L., Kingsley K., and Plopper, G.E. Perillyl alcohol inhibits breast cell migration without affecting cell adhesion. , *Journal of Biomedicine and Biotechnology*, 2002 (in press). A copy of the accepted manuscript is attached to the end of this report.

Our preliminary data suggests that perillyl alcohol inhibits migration by interfering with Rho isoprenylation in human breast cells. These data are included in Figures 1-6 of the submitted manuscript, "Perillyl alcohol induces redistribution of RhoA and cytoskeletal disorganization in human breast cells" attached at the end of this report.

Task 4. Generate recombinant fragments of laminin-1, Months 24-40.

- a. Construct expression plasmids for use in baculovirus expression system.
- b. Infect insect cells, isolate protein fragments.
- c. Characterize purified fragments: glycosylation, adhesion promoting activity, integrin binding, etc.

These tasks have been completed. Unfortunately, the yield was so low we were unable to use them in any functional assays. We did succeed in expressing one fragment, G4, in *E. coli*, and found that it supports  $\beta 1$  integrin-mediated adhesion of human mesenchymal stem cells. Breast cells adhere very weakly to this fragment.

- d. Determine migration activity of normal and malignant cells on fragments.

We did not attempt this task, because our laminin-1 fragments were not produced in sufficient quantity.

Task 5. Examine integrin-specific signaling in isolated laminin-1 fragments, Months 36-48.

- a. Microscopy: Effects on cell shape, focal adhesion formation, cytoskeletal rearrangements.

- b. Calcium signaling: Examine calcium flux on fragments.
- c. Other signaling: FAK Phosphorylation, phosphatidylinositol-3 kinase activity, rho/rac GTP binding activity.

These assays were not done because we were unable to generate enough fragments to complete the study.

### **Key Research Accomplishments**

- Design and manufacture of 96-well fluorescence-based cell migration plates
- Establishment of automated cell migration/cytotoxicity assay suitable for screening thousands of potential inhibitors of breast cancer cell migration per year
- Established research methods for examining Ca<sup>+2</sup> signaling in migrating populations of breast cells
- Identification of RACK1 as an inhibitor of CHO cell migration.
- Identification of FAK as a laminin-5 signaling protein in human breast cells
- Identification of Ca<sup>+2</sup> as an essential component of cell migration signaling in breast cells
- Identification of perillyl alcohol as a non-cytotoxic inhibitor of breast cell migration
- Determination that perillyl alcohol inhibits RhoA membrane association in breast cells

### **Reportable Outcomes:**

#### manuscripts

Plopper, G.E., Domanico, S., Kioses, B., and V. Quaranta. Laminin-5 induced adhesion and migration in mammary epithelial cells: Differential role of  $\alpha 3\beta 1$  integrin in normal and transformed cell types. *Breast Cancer Research and Treatment* 51:57-69, 1998.

Rust, W., K. Kingsley, T. Petnicki, S. Padmanabhan, S.W. Carper, and G.E. Plopper. Hsp27 plays two distinct roles in controlling human breast cancer cell migration on laminin-5. *Molecular Cell Biology Research Communications*, 1:196-202, 1999.

Rust, W.L., J.L. Huff, and G.E. Plopper. Screening assay for pro/anti-migratory compounds. *Analytical Biochemistry*, 280:11-19, 2000.

Plopper, G.E., J.L. Huff, W.L. Rust, M.A. Schwartz, and V. Quaranta. Antibody induced activation of  $\beta 1$  integrin receptors stimulates cAMP-dependent migration of breast cells on laminin-5. *Molecular Cell Biology Research Communications*, 4:129-135, 2000.

Buensuceso, C.S., D. Woodside, J.L. Huff, G.E. Plopper, and T.E. O'Toole. The WD protein Rack1 mediates PKC and integrin dependent cell migration. *Journal of Cell Science*, 114:1691-1698, 2001.

Rust, W., Carper, S., and Plopper, G.E. The promise of integrins as effective targets for anti-cancer agents (invited review). *Journal of Biomedicine and Biotechnology*, 2002 (in press).

Wagner, J.E., Huff, J.L., Rust W.L., Kingsley K., and Plopper, G.E. Perillyl alcohol inhibits breast cell migration without affecting cell adhesion. *Journal of Biomedicine and Biotechnology*, 2002 (in press).

#### Abstracts (Attached to previous annual reports)

Rust, W.L., T. Petnicki, S. Carper, and G.E. Plopper. HSP27 enhances MAP kinase dependent migration of breast cancer cells. *Molecular Biology of the Cell* 9:288a, 1998.

Rust, W.L., J.L. Huff, and G.E. Plopper. A high-throughput assay for screening anti-migratory compounds. *Molecular Biology of the Cell* 10:267a, 1999.

Wagner, J.E., C. DiGennaro, J.A. Elegbede, W. Rust, and G.E. Plopper. Application of an automated, high-throughput assay to identify perillyl alcohol as a non-cytotoxic inhibitor of breast cancer migration. *Molecular Biology of the Cell* 10:262a, 1999.

Carroll, K.J., V.J. Cavaretta, R.W. Bandle, J.L. Huff, M.A. Schwartz, V. Quaranta, and G.E. Plopper. Stimulation of breast cell migration on laminin-5 by antibody induced activation of  $\alpha 3\beta 1$  integrin receptor and a G $\alpha$ i3-mediated signaling pathway. *Molecular Biology of the Cell* 10:339a, 1999.

Early, B., J. Huff, and G. Plopper. The role of focal adhesion kinase in integrin-mediated migration of breast cells on laminin-5. *Journal of Investigative Medicine* 49(1):420, 2000.

presentations

In vitro analysis of cancer cell migration signaling. Grand Rounds, Department of Surgery, University of Nevada School of Medicine, Las Vegas NV, 1999.

In vitro analysis of integrin signaling and cancer cell migration. Department of Molecular Biology and Immunology, University of North Texas Health Science Center, Fort Worth, TX, October 2000.

In vitro analysis of integrin signaling and tumor cell migration. Department of Biology, State University of New York, Geneseo, 2001.

In vitro analysis of integrin signaling and cell migration. Department of Biology, Rensselaer Polytechnic Institute, Troy NY, 2001.

degrees obtained that are supported by this award

N/A

development of cell lines, tissue or serum repositories

N/A

informatics such as databases and animal models, etc.

N/A

funding applied for based on work supported by this award

1. UNLV Strategic Planning Initiative Grant. Title: Biomedical engineering: Blood flow and cancer therapy. Total amount: \$30,000. July 1, 1999-June 30, 2000. Submitted January 22, 1999.
2. UNLV Strategic Planning Initiative Grant. Title: Establishment of the UNLV Cancer Institute (Officially listed as collaborator, Steven Carper is PI). Total amount: \$30,000. July 1, 1999-June 30, 2000. Submitted January 22, 1999.
3. United States Army Breast Cancer Research Program, Idea Grant. Title: Application of a high-throughput in vitro assay to identify inhibitors of human breast cancer cell migration. Total amount, \$335,250. June 1, 2000-May 31, 2003. Submitted June 2, 1999.
4. United States Army Breast Cancer Research Program, Predoctoral Training Grant. Title: Elucidation of pertussis toxin-sensitive migration signaling in human breast cancer cells (Officially listed as mentor: Will Rust is PI). Total amount, \$66,000. June 1, 2000-May 31, 2003. Submitted June 2, 1999.
5. United States Army Breast Cancer Research Program, Postdoctoral Training Grant. Title: The Role of Focal Adhesion Kinase and CAS in Integrin-mediated Signaling on Distinct Forms of Laminin-5 (Officially listed as mentor: Janice Huff is PI). Total amount: \$143,889. June 1, 2000-May 31, 2003. Submitted June 2, 1999.
6. WAESO summer 1999 minority student research project. Title: Function of laminin-5 in vascular smooth muscle cell migration. Total amount, \$1,378. Submitted April 1, 1999.
7. WAESO fall 1999 minority student research project. Title: Signal Transduction in Human Breast Cancer Cells. Total amount, \$1,378. Submitted May 1, 1999.
8. The Whitaker Foundation, Biomedical Engineering Research Grant (Officially listed as collaborator: Bingmei Fu, UNLV Dept. of Mechanical Engineering, is PI). Title: VEGF induced hyperpermeability and its role in tumor metastasis in intact microvessels. Total amount: \$205,675. December 1, 1999-November 31, 2002. Submitted June 1, 1999.
9. American Institute for Cancer Research, Investigator Initiated Grant. Title: Application of an automated assay to discover natural inhibitors of cancer cell migration. Total amount, \$149,923. Submitted July 1, 1999.
10. UNLV Applied Research Program. Title: A UNLV/Biotechnology Collaboration. Total amount, \$577,816. September 1, 1999-August 31, 2001. Submitted August 5, 1999.
11. National Institutes of Health, R21 Grant: Insight Awards to Stamp Out Breast Cancer. Title: In Vitro Screen for Inhibitors of Cancer Cell Migration. Total amount, \$222,580. July 1, 2000- June 30, 2002. Submitted October 12, 1999.
12. UNLV Travel Committee, Application for Travel Funds. Amount requested: \$667, for travel to American Society for Cell Biology annual meeting in December 1999. Submitted October 20, 1999.
13. Principle Investigator, US Army Breast Cancer Research Project Concept Proposal. Title: Structural derivatives of d-limonene as inhibitors of breast cell migration. Total amount, \$75,000. Dates: July 1, 2000-Mune 30-2001. Submitted April 12, 2000.
14. Principle Investigator, UNLV Applied Research Program. Title: A UNLV/Biotechnology Collaboration. Total amount, \$270,000. June 1, 2000-May 31, 2001. Submitted March 1, 2000.
15. Collaborator, 30% effort, National Institutes of Health Small Business Technology Transfer (STTR) Program, Phase I grant. Title: Migration/Death assay for tumor chemosensitivity testing (Janice Huff, PI). Total amount, \$100,000. Dates: January 1, 2001-August 1, 2001. Submitted March 30, 2000.
16. Collaborator, 5% effort, National Institutes of Health Research Grant (RO1), competitive renewal, Title: Mechanisms of hyperbaric oxygen in ischemia-reperfusion (William Zamboni, MD, UNSOM,

- PI). Dates: February 1, 2000-January 31, 2004. Total amount: \$1,179,017. Submitted February 8, 2000.
17. Mentor, Regents Award Program, UNLV. Title: N/A. \$14,400. Grant period runs 2000-2001 academic year.
  18. Principle Investigator, WAESO Undergraduate Research Program. Title: Laminin-5 signalling in vascular smooth muscle cells. Dates: September 1, 2000-December 31, 2000. \$1378.
  19. Principle Investigator, WAESO Undergraduate Research Program. Title: Laminin-5 in vascular smooth muscle cell migration. Dates: September 1, 2000-December 31, 2000. \$1378.
  20. Co-Principle Investigator, Fund for a Healthy Nevada Grant Program. Title: Early detection, treatment, and biology of lung cancer in Nevada women. Total amount, \$1,608,099. Dates: December 1, 2000-November 30, 2002. Submitted August 22, 2000.
  21. Mentor, Undergraduate Research Grant (Brian Earley, PI), \$1,000. Submitted November 1 2000.
  22. PI, McNair Scholars Program Fund, UNLV, \$1,000. No title. Submitted September 3, 2000. Establishment of a bioengineering facility, UNLV Strategic Planning Initiative, \$30,000, June 1, 1998-May 31, 1999.
  23. Development of a novel automated cell migration assay, UNLV Strategic Planning Initiative, \$135,200, Start June 1, 1998, end May 31, 1999. Submitted March 2, 1998.
  24. Cancer Cell Migration as a Target for Anti-tumor Drug Design, American Cancer Society. \$445,376. Start January 1, 1999, end December 31, 2001. Submitted March 31, 1998.
  25. Applied research in cardiovascular disease. UNLV Strategic Planning Initiative, \$44,300. Start June 1, 1998, end May 31, 1999. Submitted May 1, 1998.
  26. Cell adhesion proteins, electromagnetic fields, and breast cancer. Western Alliance for Expanding Student Opportunities (Arizona State University), \$1,744. Summer 1998 Semester. Submitted May 4<sup>th</sup>, 1998.
  27. Electromagnetic field modification of cell adhesion proteins. Western Alliance for Expanding Student Opportunities (Arizona State University), \$1,744. Summer 1998 Semester. Submitted May 4<sup>th</sup>, 1998.
  28. Heterotrimeric G proteins as targets for tumor cell migration. Susan G. Komen Breast Cancer Foundation, \$177,840. Start Jan. 1, 1999, end December 31, 2000. Submitted May 14, 1998.
  29. Eagles Art Ehrmann Cancer Fund grant, Fraternal Order of Eagles (Las Vegas, NV). \$10,000. No specified start/end dates. Submitted May 14, 1998.
  30. Novel Integrin-Extracellular Matrix Interactions as Functional Targets for Anti-tumor Drug Design. United States Army Breast Cancer Research Program, Postdoctoral Grant (Janice Huff, P.I.), \$126,000. Start June 1, 1999, end May 31, 2002. Submitted June 30, 1998.
  31. Functional Characterization of Novel Integrin-Extracellular Matrix Interactions. Schleicher & Schuell Postdoctoral Fellowship (Janice Huff, P.I.). \$54,000. Start date January 1, 1999. End date December 31, 2000. Submitted June 30, 1998.
  32. HSP27 as a Key Player in Metastatic Progression in Breast Cancer Cells. United States Army Breast Cancer Research Program, Predoctoral Grant (Will Rust, P.I.), \$66,000. Start June 1, 1999, end May 31, 2002. Submitted June 30, 1998.
  33. UNLV student research on HSP27 and breast cancer. \$5,000. Submitted 9/20/98 to UNLV Alumni Association.
  34. UNLV student research on effects of electromagnetism on breast cancer. \$5,000. Submitted 9/20/98 to UNLV Alumni Association.
  35. Integrin signaling and migration of breast cancer cells on laminin-5. American Cancer Society research project grant, \$444,000. Start date June 1, 1999, end May 31, 2002. Submitted October 15, 1998.
  36. VEGF induced hyperpermeability and its role in tumor metastasis in intact microvessels. Whitaker

Foundation Biomedical Engineering Research Grant preproposal (Bingmei Fu, PI; George Plopper, Co-Investigator). Submitted December 1, 1998. No start/stop dates indicated. Invited to submit full application as of December 22, 1998.

37. Cell adhesion proteins, electromagnetic fields, and breast cancer. Western Alliance for Expanding Student Opportunities (Arizona State University) \$1,378. Spring 1999 Semester. Submitted December 3, 1998.
38. Electromagnetic field modification of cell adhesion proteins. Western Alliance for Expanding Student Opportunities (Arizona State University) \$1,378. Spring 1999 Semester. Submitted December 3, 1998.
39. UNLV Site Grant, \$5,000, submitted December 28, 1998. Proposed dates: April 1, 1999-December 31, 1999.
40. Biomedical Engineering and Anti-cancer Drug Design. Strategic Planning Initiative Grant, \$30,000. Bingmei Fu, Ph.D., Co-investigator. Submitted December 28, 1998. Start date: June 1, 1999. Stop date: May 31, 2000.

employment or research opportunities applied for and/or received based on experiences/training supported by this award

PI was appointed Assistant Professor, Department of Biology, Rensselaer Polytechnic Institute, Troy NY, effective July 23, 2001. Full contact information:

George Plopper, Ph.D.  
Assistant Professor  
Department of Biology  
Rensselaer Polytechnic Institute  
110 8<sup>th</sup> Street  
Troy NY 12180-3590  
(518) 276-8288 office  
(518) 276-2162 fax  
ploppg@rpi.edu

### **Conclusions.**

In this report we demonstrate the successful application of a novel anti-migration assay we have developed to establish that perillyl alcohol inhibits the migration of normal and malignant cells at concentrations that are non-toxic to normal cells. We also have generated important research tools (bacterial and insect plasmids encoding secreted forms of laminin-1 fragments) that should enable us to carefully examine the migratory signaling that arises from specific integrin receptors bound to a native substrate. Our major limitations at this point are finding a source of funding to conduct a large-scale screen of other potential migration inhibiting compounds, and the relatively poor yield of the laminin fragments that slows our progress. The knowledge generated in this project is useful to the pursuit of anticancer treatments because it demonstrates an effective method for rapidly identifying anti-migratory drugs that are non-toxic. This project has also allowed us to identify key molecular players that contribute to the migration of cells and thus may serve as molecular targets of new therapies.

### **References.**

None cited.

**Appendices.**

See attached.

## Heat Shock Protein 27 Plays Two Distinct Roles in Controlling Human Breast Cancer Cell Migration on Laminin-5

Will Rust,\* Karl Kingsley,\* Tanja Petnicki,\* Sindhu Padmanabhan,†  
Stephen W. Carper,† and George E. Plopper\*<sup>1</sup>

\*Department of Biological Sciences and †Department of Chemistry, University of Nevada, Las Vegas, Nevada 89154

Received May 20, 1999

**It has recently been reported that phosphorylation of the small heat shock protein 27 (hsp27) enhances p38 MAP kinase dependent migration of bovine and human vascular endothelial cells. We have examined the role of hsp27 in controlling the constitutive migration of human breast cancer cells on the extracellular matrix molecule laminin-5. In a haptotaxis assay, anisomycin- or heat shock-induced phosphorylation of hsp27 enhances migration of MDA-MB-231 breast cancer cells constitutively overexpressing hsp27. Under these conditions, hsp27 redistributes to the nucleus. Unphosphorylated hsp27, which remains in the cytosol, induces resistance to a subset of drugs that inhibit haptotactic migration of these cells. We conclude that hsp27 plays two distinct roles in controlling migration of breast cancer cells: phosphorylated hsp27 enhances migration, while unphosphorylated hsp27 can sustain migration in the presence of inhibitory drugs.** © 1999 Academic Press

**Key Words:** heat shock protein 27; migration.

Heat shock protein 27 (hsp27) is a member of the heat shock family of proteins, which confer resistance to a variety of cellular stresses (reviewed in 1, 2). Hsp27 over-expression confers resistance to acute heat shock and some anti-cancer drugs (1, 3). hsp27 function is thought to be controlled by its phosphorylation state and intracellular localization, however, the exact mechanism remains unclear.

Following heat shock, hsp27 is phosphorylated and redistributes to the nucleus (1). This phosphorylation is mediated by mitogen activated protein kinase activated protein kinase 2/3 (MAPKAP K2/3) (1), which in turn is activated by upstream kinases ERK 1/2, JNK/

SAPK, and p38 MAPK (2-4). Phosphorylation-deficient mutants do not confer heat shock resistance, suggesting that phosphorylation is critical to its ability to protect cells from heat (3).

*In vitro*, hsp27 inhibits actin polymerization (2, 3). *In vivo*, hsp27 complexes are sometimes associated with actin filaments in motile cell protrusions such as lamellipodia, filopodia, and membrane ruffles (5), suggesting it may play a role in controlling cell motility or cytokinesis, though its exact role in these activities is unclear (6, 7).

Extracellular matrix (ECM) proteins play a critical role in controlling numerous functions in virtually all cells, including migration (8, 9). The ECM protein laminin-5 is abundantly expressed in the basal lamina of most epithelial tissues, where it promotes growth, differentiation, and migration of epithelial cells (10-12). In the breast, laminin-5 is the preferred adhesive substrate for normal breast epithelial cells and mediates constitutive migration of breast cancer cells (9). The relationship between hsp27 over-expression and laminin-5 mediated migration in breast cells has thus far been unexplored.

In the present study, we show that hsp27 over-expression alone does not affect constitutive migration of MDA-MB-231 human breast cancer cells towards laminin-5. However, phosphorylation of hsp27 by heat shock or MAPK activation enhances this migration over control cells, concomitant with its re-localization to the nucleus. In addition, unphosphorylated hsp27 confers resistance to drugs that inhibit cell migration, and is localized to the cytosol. From these results, we conclude that hsp27 modulates migration on laminin-5 by two distinct mechanisms, that can be distinguished by hsp27 phosphorylation state: phosphorylated hsp27 enhances migration, while unphosphorylated hsp27 offers protection against migration inhibitors. These two distinct functions may reflect the dual role of hsp27 as

<sup>1</sup> To whom correspondence should be addressed at Department of Biological Sciences, University of Nevada, Las Vegas, 4505 Maryland Parkway, Las Vegas, NV 89154-4004. Fax: (702) 895-2956. E-mail: plopper@nye.nvcc.edu.

an actin polymerization modulator and molecular chaperone, respectively.

## MATERIALS AND METHODS

**Cells.** MDA-MB-231 cells were maintained as previously described (9). DB46 cell line was made by transfecting MDA-MB-231 cells with an hsp27 constitutive expression vector (p $\beta$ 27), constructed by cloning the human full length hsp27 cDNA (13) fragment into the pH $\beta$ APr-1 neo (14) under the control of the  $\beta$  actin promoter as previously described (15). Control cell line DC4 was made by transfecting cells with the same plasmid lacking the hsp27 cDNA sequence.

**Materials.** SQ22536, KT5823, H89, Bisindolylmaleimide, Genistein, and Anisomycin were purchased from Calbiochem (San Diego, CA). PD98059 was purchased from New England Biolabs (Beverly, MA); and pertussis toxin was purchased from List Biological Laboratories (Campbell, CA). Purified laminin-5 was generously provided by Desmos, Inc. (San Diego, CA).

**Immunoblotting.** Cells were scraped and lysed in RIPA lysis buffer, and lysates subjected to western blot as previously described (16). In this instance, primary antibodies were anti-hsp-27 monoclonal antibody (1:1000 dilution), Stressgen (Victoria BC, Canada) or anti-phospho-p44/42 MAP kinase (Thr202/Tyr204) monoclonal antibody (1:2500 dilution), New England BioLabs (Beverly, MA), and alkaline phosphatase conjugated anti-mouse monoclonal antibody was used as the secondary antibody.

**Quantification of apoptosis.** Apoptosis was quantified using an ELISA assay kit (Boehringer Mannheim, Indianapolis, IN). Briefly, DC4 and DB46 cells were treated with indicated concentrations of sodium butyrate for 20 hours, then solubilized according to manufacturers protocol. ELISA wells were coated with anti-histone antibody, then loaded with cytoplasmic extracts, and finally, incubated with anti-DNA secondary antibody conjugated with peroxidase. Absorbance of peroxidase substrate was measured at 405nm using a Microplate autoreader (Dynatech MR5000).

**Heat shock survival.** Survival after exposure to 45°C for various time intervals was determined by colony forming assay as previously described (17). Briefly, cells were heat shocked at 45°C, then allowed to grow for 9–12 days. Colonies (>50 cells) were stained with crystal violet and counted. Percent survival is expressed relative to control, unshocked cells.

**Transwell haptotactic migration assay.** Cell migration was determined as previously described (9) except that cells were stained with 5  $\mu$ M calcein AM, Molecular Probes (Eugene, OR) added directly to the migration wells 30 minutes prior to measuring migration. To

quantitate migration, the top side of each filter was wiped with a cotton tipped applicator to remove cells that had not migrated through the filter, and fluorescence of the incorporated dye was measured from the filter with a fluorescence plate reader. Relative fluorescence values for each experimental condition are expressed relative to control, untreated samples.

**Phosphorylation assay.** Cells were pre-incubated with 100  $\mu$ Ci/ml  $^{32}$ P-orthophosphate, NEN (Boston, MA), in 90% phosphate-free medium for four hours, then subjected to either heat or drug treatment for 30 minutes. Cells were lysed in RIPA, and 15  $\mu$ g of cell lysates was immunoprecipitated with anti-hsp27 antibody and protein A/G agarose, Santa Cruz Biotechnology (Santa Cruz, CA). Immunoprecipitates were separated by SDS-PAGE (12% acrylamide), and the dried gel was exposed to film. MAP kinase phosphorylation was determined by immunoblotting with monoclonal antibody specific for phosphorylated MAP kinase.

**Miscellaneous.** Cell adhesion, immunoprecipitation, and indirect immunofluorescence assays were performed as previously described (16), using anti-hsp-27 monoclonal antibody and anti-phospho-p44/42 MAP kinase (Thr202/Tyr204) monoclonal antibody (New England BioLabs, Beverly, MA) as primary antibodies where indicated. For affinity captured laminin-5 assays, untreated wells were coated with anti laminin-5 monoclonal antibody TR-1 (20  $\mu$ g/ml) in 100 mM carbonate buffer (pH 9.3) for one hour at room temperature. After washing and blocking with blotto, wells were incubated for 1 hour at room temperature with 804G cell conditioned medium, thereby allowing for "capture" of soluble laminin-5. Wells were then washed twice with PBST.

## RESULTS

### *The Human Breast Cell Line DB46 Stably Overexpresses hsp27*

To examine the effect of hsp27 over-expression on the behavior of human breast cancer cells, we stably transfected clones of MDA-MB-231 cells with the p $\beta$ 27 plasmid containing full length human hsp27 cDNA under the control of the  $\beta$ -actin promoter (15). Overexpression of hsp27 in transfected clones was confirmed by Western blot (Fig. 1A), and function of hsp27 in these cells was determined by resistance to sodium butyrate-induced apoptosis and heat shock (Fig. 1B, C). We found that DB46 cells expressed 2-3 fold more hsp27 and exhibited increased (10- to 100-fold greater) survival when compared to control DC4 cells. From these results we conclude that DB46 cells constitutively over-express functional hsp27.

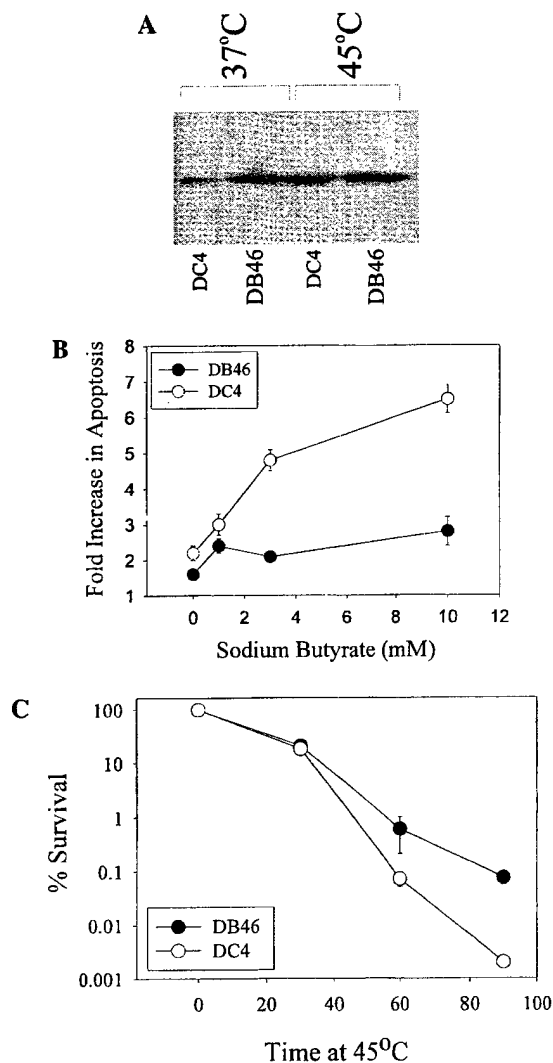

**FIG. 1.** DB46 cells overexpress hsp27. (A) Western blot for hsp27 in resting (37°C) and heat shocked (45°C) DB46 cells transfected with hsp27. As a control, parallel analysis was performed on lysates from DC4 cells transfected with a control plasmid. Note that at both 37°C and 45°C, DB46 cells contain approximately two- to three-fold more hsp27 than control cells. (B) Dose response analysis of sodium butyrate-induced apoptosis. Note that DB46 cells exhibit four-fold less apoptosis as measured by ELISA than control cells in response to 10 mM sodium butyrate. (C) Dose response analysis of % survival of colonies following heat shock at 45°C.

#### *hsp27 Overexpression Does Not Alter Binding of DB46 Cells to Laminin-5*

Because laminin-5 plays a significant role in controlling breast cell growth, migration, and differentiation (8, 9), we compared adhesion of DB46 and DC4 cells to laminin-5 using 30 minute cell adhesion assays. We found no difference between cell lines in adhesion to purified laminin-5 (Fig. 2). Laminin-5 was one of the most preferred adhesive substrates compared to additional ECM proteins (laminin-1, collagen IV, fibronectin).

#### *Phosphorylation of hsp27 by MAP Kinase Enhances Migration of DB46 Cells on Laminin-5*

We determined the impact of hsp27 over-expression on haptotactic migration towards laminin-5 using *in vitro* Transwell assays. DB46 cells retained the constitutive migration of parental MDA-MB-231 cells on laminin-5, as did control DC4 cells (Fig. 3). Therefore, hsp27 overexpression alone does not significantly affect migration of DB46 cells. Under these conditions, hsp27 was weakly phosphorylated in both DB46 and DC4 cells. However, stimulation of hsp27 by exposure to 41°C, or via activation of MAP kinase with 10 ng/ml anisomycin, led to a significant (29–53%) enhancement of migration in DB46 cells (Fig. 3A). Under these conditions, both ERK 1/2 and hsp27 were phosphorylated, as determined by western blot with anti-phospho-ERK 1/2 antibody (Fig. 3B) and immunoprecipitation of hsp27 from  $^{32}\text{PO}_4$  radiolabeled cells (Fig. 3C). Addition of the MEK1 (upstream activator of ERK 1/2) inhibitor PD98059 did not significantly inhibit migration under normal conditions. These results indicate that hsp27 phosphorylation by heat or MAP kinase activation enhances migration. While hsp27 phosphorylation correlated with enhanced migration in DB46 cells, the degree of migration enhancement varied with the relative phosphorylation of MAP kinase.

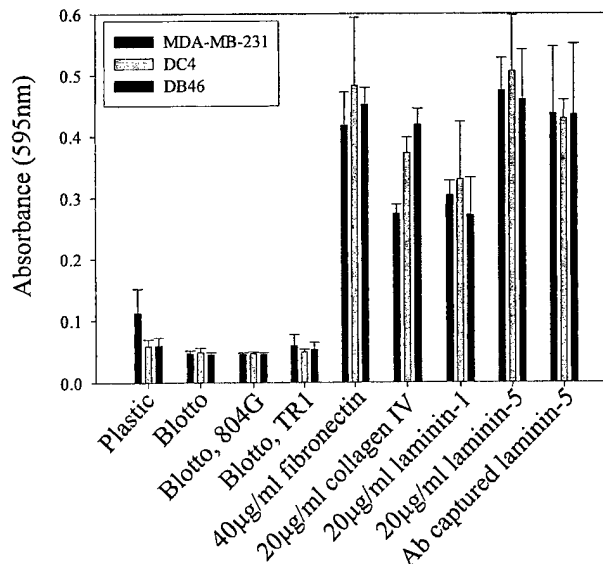

**FIG. 2.** hsp27 overexpression does not alter cell adhesion of DB46 cells to laminin-5. DB46, DC4, and parental MDA-MB-231 cells were plated on the indicated ECM proteins for 30 minutes, gently washed to remove unbound cells, then fixed, stained, and quantitated as previously described using mouse laminins, collagen IV and bovine fibronectin. TR1 = mouse monoclonal anti-laminin-5 antibody, 804G = conditioned medium from rat 804G cells containing laminin-5. Laminin-5 was captured by affinity method using TR1 antibody as described previously. Data are presented as statistical mean  $\pm$  standard deviation (n = 16).

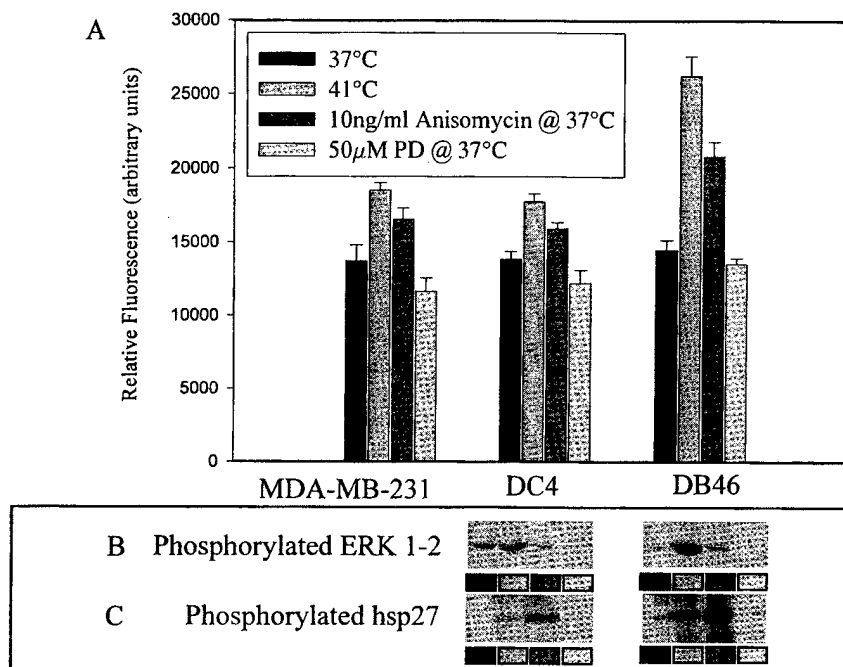

**FIG. 3.** Phosphorylation of hsp27 by MAP kinase enhances migration of DB46 cells on laminin-5. (A) Haptotactic migration assay on laminin-5. During the entire migration period, cells were exposed to mild heat shock (41°C), 10 nM anisomycin, or 50 µM PD98059. Results expressed as the statistical mean of the mean measurement from each filter,  $\pm$  standard error of the means (n = 4). (B) Western blot analysis of ERK 1/2 phosphorylation with anti phospho-MAP kinase antibody. Cells were exposed to the indicated conditions for 30 minutes, then lysed and processed for western blot analysis. (C) Immunoprecipitation analysis of phosphorylated hsp27.

#### DB46 Cells Resist a Subset of Migration Inhibiting Drugs

hsp27 overexpression confers resistance to drugs that induce apoptosis and inhibit growth, possibly by modulating intracellular signaling pathways. To test the hypothesis that hsp27 influences laminin-5-associated migration signaling pathways, we repeated our cell migration assays in the presence of several drugs that inhibited intracellular signaling molecules and reduced migration of parental cells.

We found that DB46 cells were less sensitive to a subset of these drugs than the DC4 control cells. Specifically, these cells were less sensitive to the migration inhibiting effects of pertussis toxin (1 µg/ml) (74% vs. 51% of control migration), which inhibits activation of the heterotrimeric G protein subunit  $G\alpha_i$ ; and completely insensitive to a sublethal dose of a specific inhibitor of PKG (KT5823, 10 µg/ml) (96% vs. 43% of control migration) (Fig. 4). In contrast DB46 cells were equally sensitive to inhibitors of adenylate cyclase (SQ22536, 50 µM), protein kinase A (H89, 10 µM), protein kinase C (bisindolylmaleimide, 10 µM) and protein tyrosine kinases (genistein, 50 µM) (Fig. 4). Thus, hsp27 protection under these conditions is not broadly applied but specific to certain signaling pathways involving at least PKG and  $G\alpha_i$ .

#### The hsp27 That Confers Resistance to Migration-Inhibiting Drugs Is Unphosphorylated

Because hsp27-enhanced migration of DB46 cells is phosphorylation-dependent, we determined the phosphorylation state of hsp27 under conditions where it

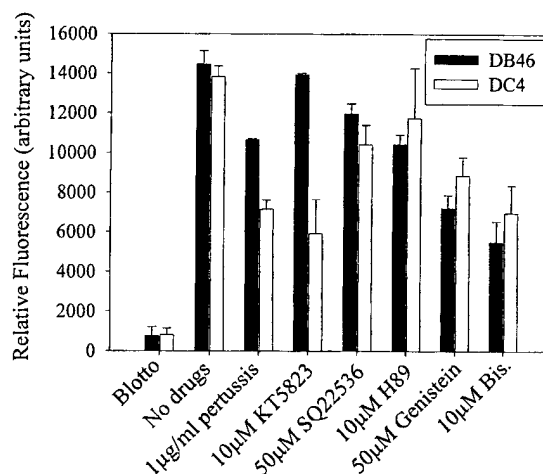

**FIG. 4.** DB46 cells resist a subset of migration-inhibiting drugs. Migration assays were performed as in Fig. 3, except that cells were plated in the presence of indicated concentrations of inhibitory drugs. Results expressed as the statistical mean of the mean measurement from each filter,  $\pm$  standard deviation (n = 4).

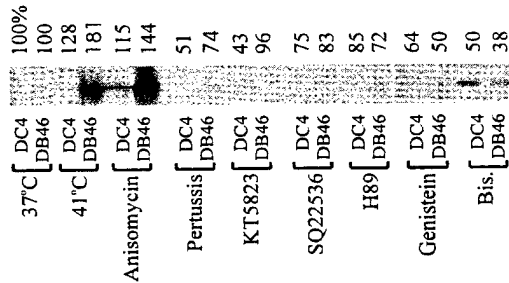

**FIG. 5.** Correlation of migration to hsp27 phosphorylation state. Percent migration data (above) obtained from Figs. 3A and 4. Immunoprecipitation analysis of phosphorylated hsp27 performed as described in Materials and Methods using anti hsp27 Ab.

conferred resistance to migration inhibiting drugs. Identical concentrations of drugs used to inhibit migration were administered to  $^{32}\text{PO}_4$ -labeled cells for 30 minutes, and hsp27 phosphorylation was determined by immunoprecipitation and autoradiography. Except for modest phosphorylation by bisindolylmaleimide, no drug treatment induced hsp27 phosphorylation over background levels (Fig. 5). These results demonstrate that hsp27 plays two discrete roles in controlling migration in DB46 cells: unphosphorylated hsp27 protects against the migration-inhibiting effects of pertussis toxin and KT5823, while only phosphorylated hsp27 enhances MAP kinase-dependent migration. Percent migration relative to control (37°C, no drugs) is indicated above band for each treatment.

#### *Enhancement of Migration by Phosphorylated hsp27 Correlates with Its Relocalization to the Nucleus*

Phosphorylation of hsp27 can affect its intracellular localization (18). Because we observed that hsp27 phosphorylation distinguished between its migration-enhancing or drug resisting effects, we determined its subcellular localization under both conditions. Indirect immunofluorescence microscopy revealed that, in the absence of heat shock or drug treatments, hsp27 was distributed throughout the cytosol with a slight concentration in the perinuclear region (Fig. 6, panel B). Upon heat stimulation or treatment with anisomycin, hsp27 relocated to the nucleus within 45 minutes (Fig. 6, panels F, H). In contrast, hsp27 did not relocalize in cells treated with pertussis toxin (Fig. 6, panel D).

From the above data, we conclude that hsp27 plays two distinct roles in controlling migration of DB46 cells on laminin-5: when phosphorylated, hsp27 concentrates in the nucleus and enhances constitutive migration, while unphosphorylated hsp27 remains distributed throughout the cytosol and offers resistance to a subset of signaling inhibitors that reduce constitutive migration.

## DISCUSSION

Our data present three lines of evidence that hsp27 acts in two distinct roles to affect cell migration. First, activation of MAP kinase cascades by anisomycin leads to phosphorylation of hsp27 and enhanced migration. While overexpression of hsp27 can enhance cell migration in a phosphorylation dependent manner (19), the upstream signaling mechanisms responsible for mediating this effect are not well defined. In endothelial cells, p38 and SAPK2, but not ERK 1/2, mediate hsp27-dependent modulation of the actin cytoskeleton and chemotactic migration (4, 20, 21). However, the MAP kinase ERK 1/2 is implicated in ECM mediated events and may be involved in haptotactic migration on laminin-5 (22). Inhibition of ERK 1/2 by PD98059 did not inhibit haptotactic migration on laminin-5, though its phosphorylation by anisomycin did correlate with enhanced migration. This result does not rule out the involvement of p38 and SAPK, both of which are activated by anisomycin (23).

Second, unphosphorylated hsp27 offers protection against inhibitors of specific intracellular signaling molecules in our cells. Hsp27 selectively protects against cytotoxic compounds, some of which stimulate intracellular signaling cascades (24, 25), perhaps by acting as a molecular chaperone (24); this protection is not always phosphorylation dependent (26). In our cells, hsp27 confers resistance to the repression of migration by inhibitors of PKG and adenylate cyclase, but not inhibitors of PKA and PKC. These results raise the possibility that hsp27 may function as a molecular chaperone or signaling molecule to maintain activity of a subset of signaling pathways required for constitutive migration of malignant tumor cells.

Third, hsp27 redistributes to the nucleus and sites of actin polymerization when phosphorylated, and remains cytosolic when unphosphorylated. This differential distribution correlates with the two distinct functions we observe in our cells, enhancement of migration, and protection against signaling inhibitors. Others have reported similar changes in distribution of hsp27 in response to serum stimulation (2, 18), although re-localization in response to heat shock may be independent of hsp27 phosphorylation (5).

In summary, the most significant finding of this study is that hsp27 affects migration of breast cancer cells by two distinct mechanisms. Further, these mechanisms can be distinguished on the basis of hsp27 phosphorylation state and intracellular localization. Because hsp27 is thought to act as a molecular chaperone, our data support a model whereby unphosphorylated hsp27 sequesters damaged signaling molecules, thereby conferring resistance to drugs that otherwise inhibit haptotactic migration of breast cancer cells. Further, because phosphorylated hsp27 functions as an actin capping protein *in vitro* (4), this may explain why it enhances constitutive

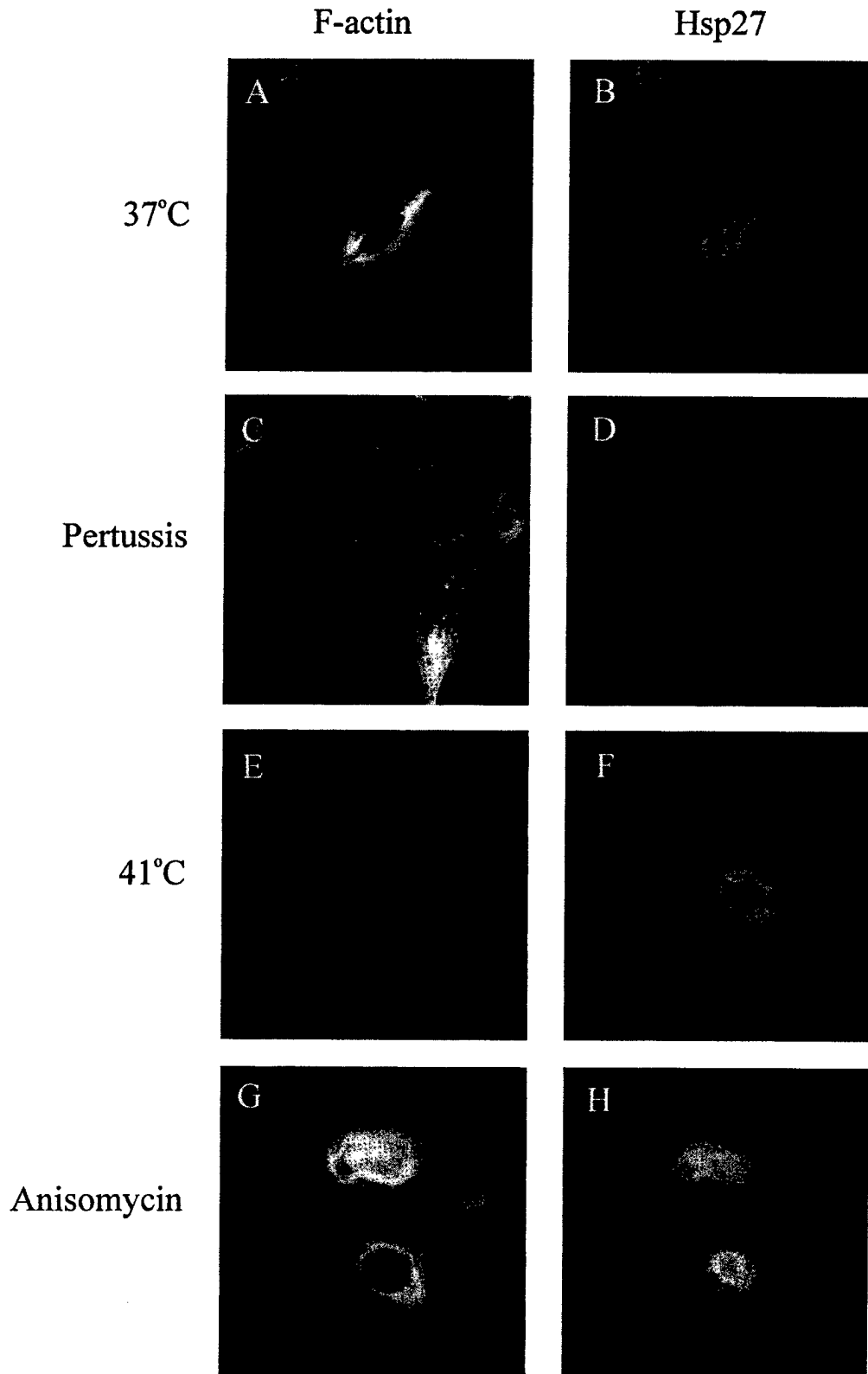

**FIG. 6.** Localization of hsp27 and f-actin. Fluorescence micrographs of DB46 cells doubly stained for actin (phalloidin) and hsp27. Magnification = 400 $\times$ .

migration of breast cancer cells: In our model, phosphorylation of hsp27, coupled with a haptotactic migration stimulus (e.g., binding to ECM proteins such as laminin-5), may enhance actin filament assembly within the leading edge of migrating cells.

#### ACKNOWLEDGMENTS

We thank Rhonda Snook for help with generating the immunofluorescence micrographs and Janice Huff for critical reading of the manuscript. This project was supported by grants to G.E.P. from the United States Army (#BC971342), Desmos, Inc., and the UNLV Office of Sponsored Programs.

#### REFERENCES

- Ciocca, D. R., Oesterreich, S., Chamness, G. C., McGuire, W. L., and Fuqua, S. A. (1993) *J. Natl. Cancer Inst.* **85**, 1558-1570.
- Arrigo, A. P., and Landry, J. (1994) in *The Biology of Heat Shock Proteins and Molecular Chaperones* (Morimoto, R. I., Tissieres, A., and Georgoulou, C., Eds.), pp. 335-372. Cold Spring Harbor Laboratory Press, Plainview, NJ.
- Landry, J., and Huot, J. (1995) *Biochem. Cell Biol.* **73**, 703-707.
- Guay, J., Lambert, H., Gingras-Breton, G., Lavoie, J. N., Huot, J., and Landry, J. (1997) *J. Cell Sci.* **110**, 357-368.
- Lavoie, J. N., Lambert, H., Hickey, E., Weber, L. A., and Landry, J. (1995) *Mol. Cell Biol.* **15**, 505-516.
- Lemieux, P., Oesterreich, S., Lawrence, J. A., Steeg, P. S., Hilsenbeck, S. G., Harvey, J. M., and Fuqua, S. A. (1997) *Invasion Metastasis* **17**, 113-123.
- Eskenazi, A. E., Powers, J., Pinkas, J., Oesterreich, S., Fuqua, S. A., and Frantz, C. N. (1998) *Clin. Exp. Metastasis* **16**, 283-290.
- Alberts, B., Bray, D., Lewis, J., Raff, M., Roberts, K., and Watson, J. D. (1989) *Molecular Biology of the Cell*, Garland Publishing, Inc., New York.
- Plopper, G. E., Domanico, S. Z., Cirulli, V., Kiosses, W. B., and Quaranta, V. (1998) *Breast Cancer Res. Treat.* **51**, 57-69.
- Stahl, S., Weitzman, S., and Jones, J. (1997) *J. Cell Sci.* **110**, 55-63.
- Giannelli, G., Falk-Marzillier, J., Schiraldi, O., Stetler-Stevenson, W. G., and Quaranta, V. (1997) *Science* **277**, 225-228.
- Mizushima, H., Miyagi, Y., Kikkawa, Y., Yamanaka, N., Yasumitsu, H., Misugi, K., and Miyazaki, K. (1996) *J. Biochem. (Tokyo)* **120**, 1196-1202.
- Carper, S. W., Rocheleau, T. A., and Storm, F. K. (1990) *Nucleic Acids Res.* **18**, 6457.
- Gunning, P., Leavitt, J., Muscat, G., Ng, S. Y., and Kedes, L. (1987) *Proc. Natl. Acad. Sci. USA* **84**, 4831-4835.
- Mahvi, D. M., Carper, S. W., Yu, C. O., McCausland, T. A., and Storm, F. K. (1996) *Endocrine* **4**, 269-275.
- Plopper, G. E., McNamee, H. P., Dike, L. E., Bojanowski, K., and Ingber, D. E. (1995) *Mol. Biol. Cell* **6**, 1349-1365.
- Carper, S. W., Hall, J. S., Storm, F. K. (1991) *Regional Cancer Treat.* **4**, 156-158.
- Mehlen, P., and Arrigo, A. P. (1994) *Eur. J. Biochem.* **221**, 327-334.
- Piotrowicz, R. S., Hickey, E., and Levin, E. G. (1998) *FASEB J.* **12**, 1481-1490.
- Huot, J., Houle, F., Rousseau, S., Deschesnes, R. G., Shah, G. M., and Landry, J. (1998) *J. Cell Biol.* **143**, 1361-1373.
- Rousseau, S., Houle, F., Landry, J., and Huot, J. (1997) *Oncogene* **15**, 2169-2177.
- Chen, Q., Kinch, M. S., Lin, T. H., Burrige, K., and Juliano, R. L. (1994) *J. Biol. Chem.* **269**, 26602-26605.
- Zinck, R., Cahill, M. A., Kracht, M., Sachsenmaier, C., Hipskind, R. A., and Nordheim, A. (1995) *Mol. Cell Biol.* **15**, 4930-4938.
- Arrigo, A. P. (1998) *Biol. Chem.* **379**, 19-26.
- Mehlen, P., Mehlen, A., Guillet, D., Preville, X., and Arrigo, A. P. (1995) *J. Cell Biochem.* **58**, 248-259.
- van den IJssel, P. R. L. A., Overkamp, P., Bloemendal, H., and de Jong, W. W. (1998) *Biochem. Biophys. Res. Commun.* **247**, 518-523.



## Screening Assay for Promigratory/Antimigratory Compounds

Will L. Rust, Janice L. Huff, and George E. Plopper<sup>1</sup>

*Department of Biological Sciences, University of Nevada, Las Vegas, 4505 Maryland Parkway, Box 454004, Las Vegas, Nevada 89154*

Received November 8, 1999

**Large-scale screening strategies aimed at finding anticancer drugs traditionally focus on identifying cytotoxic compounds that attack actively dividing cells. Because progression to malignancy involves acquisition of an aggressively invasive phenotype in addition to hyperproliferation, simple and effective screening strategies for finding compounds that target the invasive aspects of cancer progression may prove valuable for identifying alternative and preventative cancer therapies. Here, we describe a fluorescence-based automated assay for identifying antimigratory compounds, with the ability to discern cytotoxic from non-cytotoxic modes of action. With this assay, we analyzed the effects of two drugs on tumorigenic (MDA-MB-435) and nontumorigenic (MCF-10A) human breast cell lines. We chose to compare carboxyamidotriazole (CAI), an experimental compound shown to inhibit migration of various cell types, with tamoxifen, a common preventative and therapeutic anticancer compound. Our assay demonstrated that both these compounds inhibit migration at sublethal concentrations. Furthermore, CAI was more effective than tamoxifen at inhibiting chemotactic and haptotactic migration of both cell lines at all concentrations tested.**

© 2000 Academic Press

**Key Words:** migration; cytotoxicity; screening; CAI; tamoxifen.

Cancer progresses in two general stages. It begins as a carcinoma of clonal, hyperproliferating cells confined to the tissue of origin, which may exist for years as a benign, primary tumor. The conversion of a benign tumor to malignancy involves the acquisition of an aggressively invasive phenotype, wherein the cancer cells leave the tissue of origin and establish new tumor metastases at distant sites. Metastases are first evi-

dent at local lymph nodes, with the severest patient prognosis associated with metastases located at distant sites (1).

There are limitations to common chemotherapy regimens. The most common drugs for treating solid-tissue cancers are cytotoxic compounds that interfere with the synthesis or function of nucleic acids. These drugs target actively dividing cells of established tumorigenic colonies (2). While many are effective at treating earlier stage cancers, none are curative for later stage disease, when overt metastases are already evident. Because many tumors are not diagnosed until advanced stages, the effectiveness of these drugs is limited (3). In addition, these antiproliferative agents produce damage to normal tissues, such as immune suppression, mucositis, and hair loss, as well as side effects such as nausea and vomiting (2, 4). It is important, therefore, to identify alternative, and potentially less toxic, treatments for halting the spread of cancer. These strategies focus on preventing the conversion of tumorigenic cells to the malignant phenotype, as opposed to arresting cell growth. For example, recent chemotherapeutic advancements include the introduction of compounds with noncytotoxic mechanisms of action, such as antiangiogenic factors, growth factor antagonists, interferons, and agents that induce cellular differentiation (5–8). These noncytotoxic compounds will potentially be used to prevent the spread of cancer as well as to increase the effectiveness of cytotoxic drugs. Since the conversion from hyperproliferative to invasive disease typically takes many years, a large window exists for the use of preventative therapies (1, 3).

The cellular changes required for malignant conversion are complex, offering a large and diverse array of potential targets for the development of antimetastatic drugs. A common theme among these cellular changes is aberrant regulation of cell migration. Examples of these changes include secretion of proteases, decreased synthesis of protease inhibitors, loss of cell-cell con-

<sup>1</sup> To whom correspondence should be addressed. Fax: (702) 895-3956. E-mail: plopper@nye.nscce.edu.

tacts, modifications of cell-substrate interactions, and alteration in the response to and production of chemotactic and haptotactic stimuli during tumor-induced angiogenesis and/or metastasis (reviewed in 9-11). The identification of compounds that halt cell migration without inducing cell death may lead to creation of novel compounds that are less toxic than common antiproliferative agents (3).

Carboxyamido-triazole (CAI)<sup>2</sup> is an example of such an antimigratory compound, which is currently in stage 2 clinical trials of androgen-independent prostate cancer (12). CAI is an inhibitor of non-voltage-gated calcium channels and blocks cell migration or invasion in breast cancer cell lines (13), prostate cancer cell lines (14), ovarian cancer cell lines (3), and head and neck squamous cell carcinomas (15). The antiproliferative effect of CAI is cytostatic, not cytotoxic, as cells will recover after the removal of CAI (14, 16). This indicates that CAI inhibits signal cascades specific to migration and proliferation. Established modes of action for CAI include inhibition of nucleotide metabolism by depleting phosphoribosyl pyrophosphate (16), inhibition of arachidonic acid and phosphoinositide generation (17), and reduction of matrix metalloproteinase activity (13, 18).

While compounds such as CAI hold promise for effective cancer therapy, there is a lack of screening strategies aimed at identifying these noncytotoxic, antimigratory compounds. Here we present a fluorescence-based, high-throughput method for screening potential antimigratory compounds that is designed to discern cytotoxic from noncytotoxic mechanisms of action. Using 96- and 24-well migration filter plates with fluorescence-opaque filters, we show that cell migration can be quantitated easily and reliably with the use of the fluorescent dye calcein-AM. Cytotoxicity of compounds tested is determined by labeling nonmigrated cells with the fluorescent DNA intercalator propidium iodide. The experimental cells are doubly labeled so that migration and cytotoxicity are measured in the same assay. The use of a high-throughput format, and the novel incorporation of screens for both antimigration and cytotoxicity on the same test cells, represent major improvements in efficiency and cost over traditional transfilter migration assays.

With this method, we analyzed the effects of CAI and the well-established anti-breast cancer compound tamoxifen on migration and viability of two human breast cell lines. Both compounds inhibited migration of the breast cancer cell line MDA-MB-435 and the nontumorigenic breast cell line MCF-10A at subcyto-

toxic concentrations. Our assay demonstrated that, while MDA-MB-435 cells showed resistance to CAI-induced cell death, CAI inhibited haptotactic and chemotactic migration of both cell lines more effectively than tamoxifen.

## MATERIALS AND METHODS

### *Materials*

MTT (3-[4,5-dimethylthiazol-2-yl]-2,5-diphenyltetrazolium bromide; Thiazolyl blue) was purchased from Sigma-Aldrich Chemicals (St. Louis, MO). Calcein-AM was purchased from Molecular Probes (Eugene, OR). Tamoxifen citrate was purchased from Calbiochem-Novabiochem (La Jolla, CA). Carboxyamido-triazole (CAI) was a generous gift of Dr. Elise C. Kohn (Laboratory of Pathology, National Cancer Institute, National Institutes of Health, Bethesda, MD). Ninety-six-well fluorescence-blocking migration plates were provided by Polyfiltronics (Rockland, MA). Twenty-four-well fluorescence-blocking migration plates were a generous gift of Dr. Nancy Chung-Welch (Becton Dickinson, Bedford, MA). Information regarding the commercial availability of the 24- and 96-well fluorescence-blocking migration plates can be found at the Becton Dickinson Web site ([www.bd.com/labware/newprod/fluoroblok.html](http://www.bd.com/labware/newprod/fluoroblok.html)). Transwell migration plates were purchased from Costar (Cambridge, MA).

### *Tissue Culture*

MCF-10A and MDA-MB-435 cells were maintained as previously described (19). Cells were routinely passaged using trypsin/EDTA (Irvine Scientific).

### *Transwell Migration Assay*

Migration assays were conducted as previously described (20), with the following modifications. Transwell filters (8.0- $\mu$ m pore size, Costar) were coated with purified bovine fibronectin, mouse laminin-1, and collagen IV at 20  $\mu$ g/ml in carbonate buffer (pH 9.3) for 1 h at room temperature. A sample consisting of 120,000 cells was suspended in DME with 292  $\mu$ g/ml L-glutamine, 100 U/ml penicillin G, 100  $\mu$ g/ml streptomycin sulfate (GPS, Irvine Scientific, Santa Ana, CA), and 1 mM sodium pyruvate (GIBCO BRL, Grand Island, NY), plated on the uncoated side of the filter, and incubated in a humidified incubator containing 5% CO<sub>2</sub>. Filters were washed twice in phosphate-buffered saline (PBS), and the uncoated side of each filter was wiped with a cotton-tipped applicator to remove cells that had not migrated. Cells were then fixed in 3.7% formaldehyde for 15 min and stained with crystal violet as in the adhesion assay. Stained cells of four representative fields of each filter were counted at 400 $\times$  magnification.

<sup>2</sup> Abbreviations used: CAI, carboxyamido-triazole; PBS, phosphate-buffered saline; RFU, relative fluorescence units; MTT, 3-[4,5-dimethylthiazol-2-yl]-2,5-diphenyltetrazolium bromide; ER, estrogen receptor.

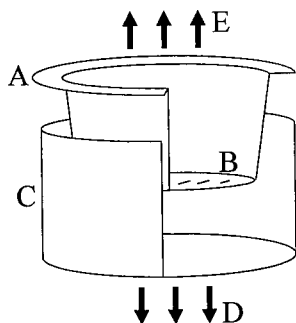

**FIG. 1.** Individual filter insert and feeder well of a 24- or 96-well migration plate. Test cells are loaded into filter insert A and allowed to migrate across a fluorescence-opaque filter B toward media in feeder well C. Cells are subsequently labeled with fluorescent indicators of cell migration and cell death. Emitted fluorescence of migrated cells is measured from underneath the filter D. Emitted fluorescence of nonviable cells is measured from above the filter E.

#### 96- and 24-Well Fluorescence Migration Assay

An individual filter insert and well of a 24- or 96-well migration plate is indicated in Fig. 1. Both 24-well and 96-well migration plates are designed as a single insert containing all filter wells in one piece. Each filter insert (A) has a UV-opaque membrane (B) with 8.0- $\mu\text{m}$  pores. Inserts fit into a well (C) of a 24- or 96-well reservoir plate. The undersides of the filters were left uncoated or were coated with 20  $\mu\text{g}/\text{ml}$  bovine plasma fibronectin, type IV collagen, or laminin-1 (GIBCO BRL) in 0.1 M acetic acid and allowed to evaporate. The filter insert was submerged in wells of feeder plate containing DME with 1 $\times$  GPS and 1 mM sodium pyruvate or DME supplemented with 1 $\times$  GPS and 10% FCS. A sample of 100,000 cells suspended in DME with 1 $\times$  GPS and 1 mM sodium pyruvate was added to the inside of each filter well (80 and 100  $\mu\text{l}$  for the 96- and 24-well plates, respectively). For drug studies, drugs were added to the cell suspension immediately before loading cells onto the migration plate. Thirty minutes before the end of the migration assay, calcein-AM was added to the feeder wells at a final concentration of 5  $\mu\text{M}$ . Filters and wells were washed twice in PBS to remove excess dye. Fluorescence of calcein-AM-labeled cells was measured from the bottom of the plate (D) in a Tecan SpectraFluor plate reader (Research Triangle Park, NC), with 485-nm excitation and 530-nm emission filters. As an indicator of cell death, propidium iodide fluorescence was measured from the top of the filter insert (E).

#### Quantification of Cell Death

Cells grown in 96-well plates were incubated for 4 h in 200  $\mu\text{l}$  per well of the appropriate media supplemented with 1.25 mg/ml MTT (3-[4,5-dimethylthiazol-2-yl]-2,5-diphenyltetrazolium bromide; Thiazolyl blue).

To release reduced MTT from viable cells, 150  $\mu\text{l}$  of media was replaced with acidic 2-propanol (99.7% 2-propanol, 0.3% 12.1 N HCl) and wells were incubated overnight at room temperature. Absorbance was measured at 570 nm vs 630 nm reference using a Tecan SpectraFluor. Quantification of cell death by fluorescence was performed as previously described (21). Briefly, 1.2 mM propidium iodide was added to media of test wells or filters to reach a final concentration of 30  $\mu\text{M}$  and incubated for 30 min at 37°C. As a positive control, cells were lysed in 1% Triton X-100 (Sigma) detergent during incubation with propidium iodide. Fluorescence of incorporated dye was measured at 560-nm excitation and 645-nm emission wavelengths using a Tecan SpectraFluor.

#### Statistical Analysis

ANOVA/*t* test was performed on data from indicated figures using a 95% confidence interval. All experiments were conducted at least three times with four to sixteen replicates per condition.

## RESULTS

#### *Fluorescence of Labeled Cells Correlates Linearly with Cell Number*

In order to quantify migrated cells automatically, cells were labeled with the live cell fluorescent indicator calcein-AM, and a standard curve comparing relative fluorescence units (RFU) vs cell number was obtained (Fig. 2). Specific numbers of prelabeled MCF-10A cells were plated in a 96-well tissue culture plate and RFU measurements of these cells correlated linearly with cell number (Fig. 2A). Because the plate reader parameters and dimensions of the plates are slightly different in a migration assay, we confirmed this correlation of cell number with RFU on migratory cells on the bottom of the migration filter. MCF-10A cells were allowed to migrate toward serum through transparent transwell filters. Nonmigratory cells were removed from the upper wells, and migratory cells measured by both calcein-AM labeling and visual counting of cells in five representative fields of each filter (Fig. 2B). Similar results were observed with MDA-MB-435 cells (data not shown).

#### *A UV-Opaque Membrane Allows for Detection of Migratory vs Nonmigratory Cells*

The use of a fluorescence-opaque membrane simplifies migration assays and allows separate detection of fluorescently labeled cells on either side of the membrane. The absorption spectrum of the membrane used in our assay is effective at blocking a UV signal through the membrane if either the emission or excitation wavelength of the fluorescent indicator used

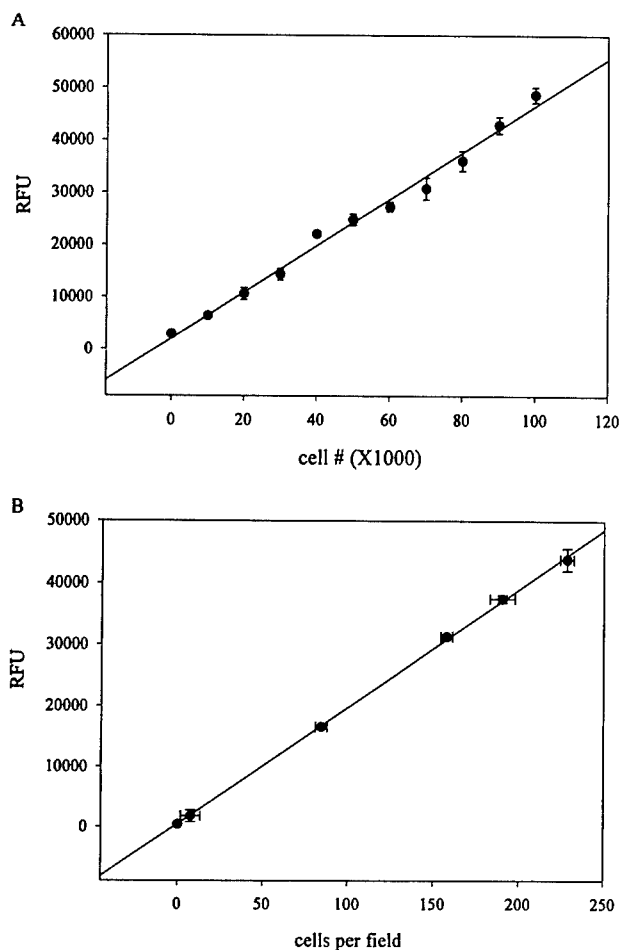

**FIG. 2.** Calcein-AM fluorescence correlates linearly with cell number. (A) The indicated number of prelabeled MCF-10A cells was plated in a 96-well plate and fluorescence intensity measured. (B) Chemotactic migration of 30,000–120,000 MCF-10A cells was measured in a transwell migration filter by calcein-AM fluorescence (y axis), and subsequently the cells were fixed and stained, and representative fields counted (x axis). Error is represented as the standard deviation of 8 wells.

falls within the absorption band (data not shown and Ref. 22). These filters effectively block the fluorescence (>95%) from the opposite side of the membrane of either of the dyes used in our assays (data not shown and Ref. 22). This membrane simplifies endpoint analysis by eliminating the need to remove nonmigratory cells before quantifying migratory cells. MCF-10A and MDA-MB-435 cells were allowed to migrate through fluorescence-opaque filters of 96- or 24-well filter plates toward serum (chemotaxis) or the indicated matrices (haptotaxis), and migration was quantified by calcein-AM labeling (Fig. 3). The data in Fig. 3 demonstrate that both cell lines migrated more toward fibronectin than other matrices. For this reason, fibronectin was chosen as the haptotactic stimulus for all drug studies. Note that fluorescence values for each cell line cannot be directly compared to each other as

different cell lines exhibit different labeling efficiencies. For example, MCF-10A cells emit a fluorescence that can be as much as 40% brighter than that emitted by similarly labeled MDA-MB-435 cells (data not shown).

#### *Cytotoxic Properties of Drugs Can Be Discerned from Antimigratory Properties with the Fluorescent Indicator Propidium Iodide*

Because a cytotoxic compound will halt migration by killing cells, the cytotoxic effects of tested compounds must be evaluated in screens for antimigratory drugs. To this end, we incorporated a fluorescence-based cytotoxicity assay that was performed in the upper well of the migration plate immediately following the migration assay. This protocol was adapted from Nieminen *et al.* (21). The DNA intercalator propidium iodide is a cell-impermeant dye whose fluorescence is increased 10-fold upon binding DNA (23). The dye is incorporated into membrane-compromised, nonviable cells and is excluded from viable cells. Propidium iodide was added to the upper well of the migration plate 30 min before the end of the migration assay. Propidium iodide fluorescence measurements inversely correlated with results obtained with the 3-[4,5-dimethylthiazol-2-yl]-2,5-diphenyltetrazolium bromide (Thiazolyl blue; MTT) cell viability assay in experiments where cells were exposed to increasing concentrations of sodium azide (Fig. 4). Similar results were seen when cells were exposed to tamoxifen and sodium arsenite (data not shown). Therefore, propidium iodide uptake can be used as a quick and reliable indicator of cell death.

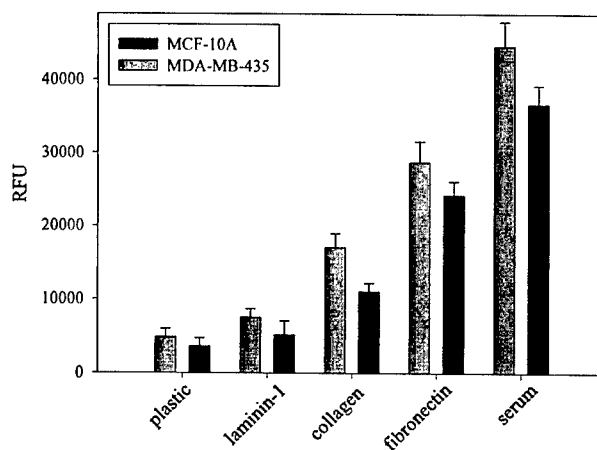

**FIG. 3.** MCF-10A and MDA-MB-435 cells each migrate with different strength toward serum and bound matrices. A sample of 120,000 cells was allowed to migrate toward the indicated stimulus in 24- and 96-well filter plates with fluorescence-opaque filters. Migrated cells were quantified by calcein-AM fluorescence. Error is represented as the standard deviation of 16 wells.

*The Potential Antimetastasis Drug CAI and the Common Anti-Breast Cancer Drug Tamoxifen Inhibited Breast Cell Migration at Noncytotoxic Concentrations*

To demonstrate the effectiveness of our assay for measuring antimigratory and cytotoxic properties of drugs, we compared CAI and tamoxifen on a nontumorigenic and a highly metastatic breast cancer cell line. Both tamoxifen and CAI inhibited migration in a dose-dependent manner at sublethal concentrations, and CAI was more effective than tamoxifen at halting migration in all cases (Fig. 5). Haptotactic migration on fibronectin was more sensitive to drug effects than chemotactic migration toward serum of both cell lines (Figs. 5A–5D). MCF-10A cells exposed to 10  $\mu$ M CAI demonstrated a 45% inhibition of haptotactic migration (Fig. 5C). At 20  $\mu$ M CAI, haptotaxis of these cells was completely abolished, and chemotaxis was inhibited 33%. In contrast, 10  $\mu$ M tamoxifen inhibited MCF-10A haptotaxis by only 17%. At 20  $\mu$ M, tamoxifen abolished haptotactic migration of MCF-10A cells and inhibited chemotaxis by 27% (Fig. 5A). MDA-MB-435 cells exposed to 10  $\mu$ M CAI demonstrated 32% inhibition of chemotaxis and 7% inhibition of chemotaxis. At 20  $\mu$ M, CAI abolished haptotaxis and inhibited chemotaxis by 42% (Fig. 5D). MDA-MB-435 cells exposed to tamoxifen, however, demonstrated nonsignificant inhibition of chemotaxis and haptotaxis at 10  $\mu$ M, and, at 20  $\mu$ M, only 51% inhibition of haptotaxis and 9% inhibition of chemotaxis (Fig. 5B). In addition, MCF-10A cell viability was more sensitive to CAI than MDA-MB-435 cells, as evidenced by increased propidium iodide fluorescence (Figs. 5C and 5D). Vehicle alone (DMSO, 95% ethanol) did not significantly affect migration in any case (data not shown).

## DISCUSSION

Several screening strategies currently exist for the identification of cytotoxic compounds, such as the National Cancer Institute's *in vitro* anticancer drug discovery screen (24). While unregulated cell migration is a nefarious aspect of cancer progression and other pathological processes such as arthritic inflammation, no high-throughput methods exist to identify inhibitors of cell migration. This is largely because conventional migration assays require excessive manipulation that reduces throughput and thus precludes them from being used in large-scale screens for antimigration compounds. In addition to the transfilter, modified Boyden chamber assay presented here, other methods for measuring cell migration include two-dimensional assays that measure random, nondirectional movement on a flat surface and three-dimensional migration/invasion assays, where cells are seeded into or allowed to invade a gelatinous matrix. We chose to use

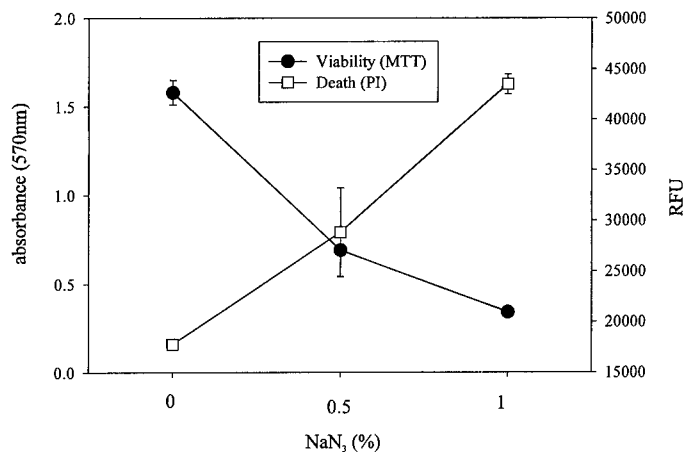

**FIG. 4.** Propidium iodide fluorescence inversely correlates with MTT absorption. A sample of 120,000 MCF-10A cells was exposed to the indicated concentrations of sodium azide ( $\text{NaN}_3$ ) for 1 h. Cell viability was measured by the MTT method (absorbance, left axis). Cell death was measured by incorporation of propidium iodide (PI) (RFU, right axis). Error is represented as the standard deviation of 16 wells.

the transfilter migration assay based on the modified Boyden chamber for ease of use and simple determination of migrated vs nonmigrated cells.

In traditional Boyden chamber filter migration and invasion assays, the migratory or invasive cells are fixed, stained, and counted visually under a microscope. In this procedure, only representative fields are chosen and counted, a process that introduces operator bias. In order to discern migratory from nonmigratory cells in these assays, nonmigratory cells must be physically removed from the upper surface of the membrane. Aside from adding extra manipulation into the assay, the assessment may only be performed once, and it is difficult to assay viability of the removed cells. Cell quantification by fluorescence detection accounts for the fluorescence contribution of every cell, thus omitting operator variability. Other protocols for simplifying the quantification of migrated cells in a modified Boyden chamber apparatus use markers of cell number that are detected after the migrated cells have been lysed. These markers include radioactivity of cell lysate from  $^{51}\text{Cr}$ -labeled cells (25), enzyme activity (26), and absorption of a cellular dye (27). Martin *et al.* (28) introduced a protocol for measuring neutrophil migration that also uses calcien-AM for the rapid and sensitive detection of migratory cells. While their protocol takes advantage of a high-throughput format (Neuro Probe, Gaithersburg, MD), this plate does not have a fluorescence-opaque filter, thus requiring that nonmigratory cells be scraped from the filter before quantification. Ours is the only protocol designed for the detection of cancer cell migration that incorporates both cell death and migration measurements of the same test cell population in the same assay.

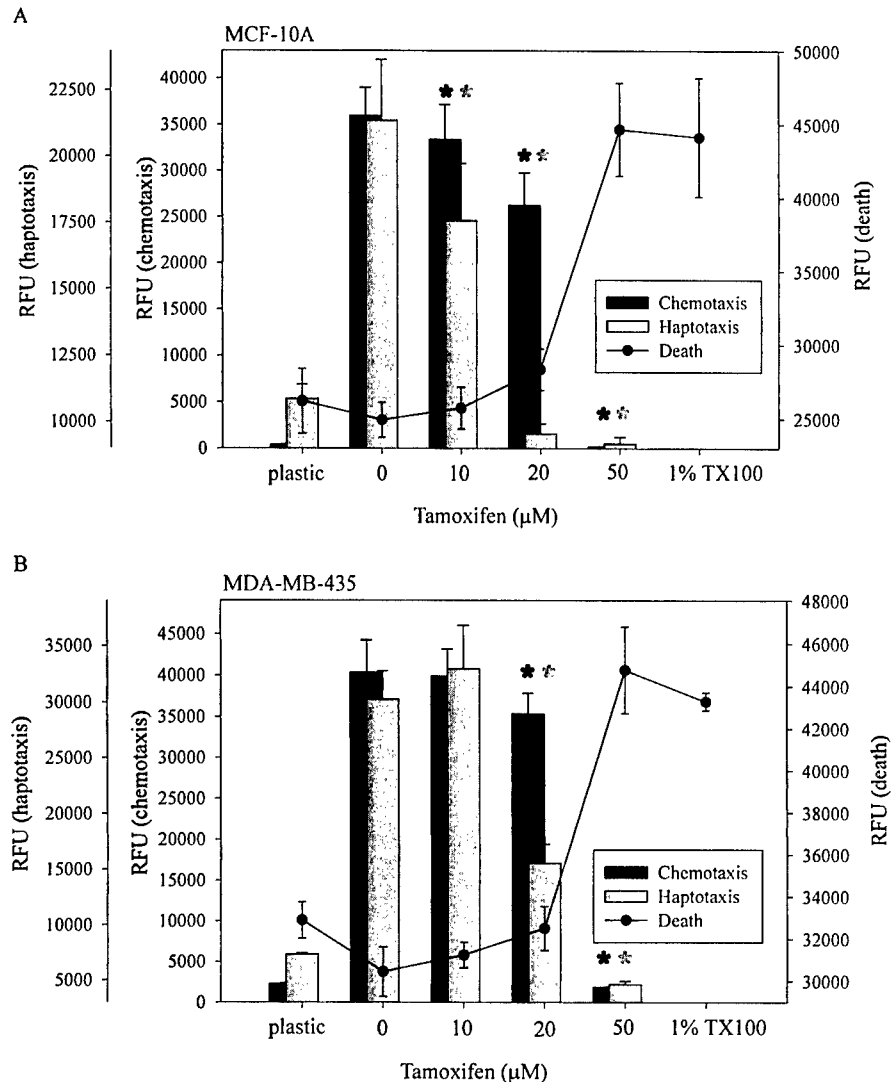

**FIG. 5.** MCF-10A (A, C) and MDA-MB-435 cells (B, D) were allowed to migrate toward serum (chemotaxis) or fibronectin (haptotaxis) in the presence of tamoxifen (A, B) or CAI (C, D). After 18 h, migrated cells were labeled with calcein-AM and fluorescence quantitated from the bottom. Nonmigrated cells were labeled with propidium iodide and fluorescence quantitated from the top. Estimation of 100% cell death was made by lysing cells in a filter well with 1% Triton X-100 (TX 100). Error bars represent the standard deviation of 4–16 replicate wells. Asterisks represent a significant difference from migration without drugs ( $P < 0.05$ ).

Typical plates designed for transfilter migration assays are capable of handling only 12–24 samples each. Improvements to this design presented in this protocol have made the Boyden chamber easier and faster to use. These improvements include increasing the numbers of test chambers per plate, decreasing the size of the test chambers, and constructing all of the test chambers as one piece, so that all samples per plate can be handled simultaneously.

The complexity of signaling cascades regulating migration indicates that many different strategies can be exploited to disturb the stimulation of migration. The ability to migrate through the tissues of the body is a complicated process, involving tissue remodeling, directed movement, and arrest at sites of action (1).

Aside from being an integral aspect of cancer metastasis, cell migration also plays an important role in normal cellular processes such as embryonic development, wound healing, angiogenesis, and the immune response. Each step is tightly regulated in normal tissues and involves the coordination of signals from extracellular matrix receptors, primarily integrins, and growth factor receptors (10, 29). The controls regulating cell movement, while incompletely understood, are diverse and vary among cell type. Compounds identified by this assay could affect any one of those processes, and identifying the mechanisms of action of those compounds could help clarify how cell migration is accomplished.

In this report, we demonstrate that tamoxifen, an antiestrogen that competes with estrogen for binding

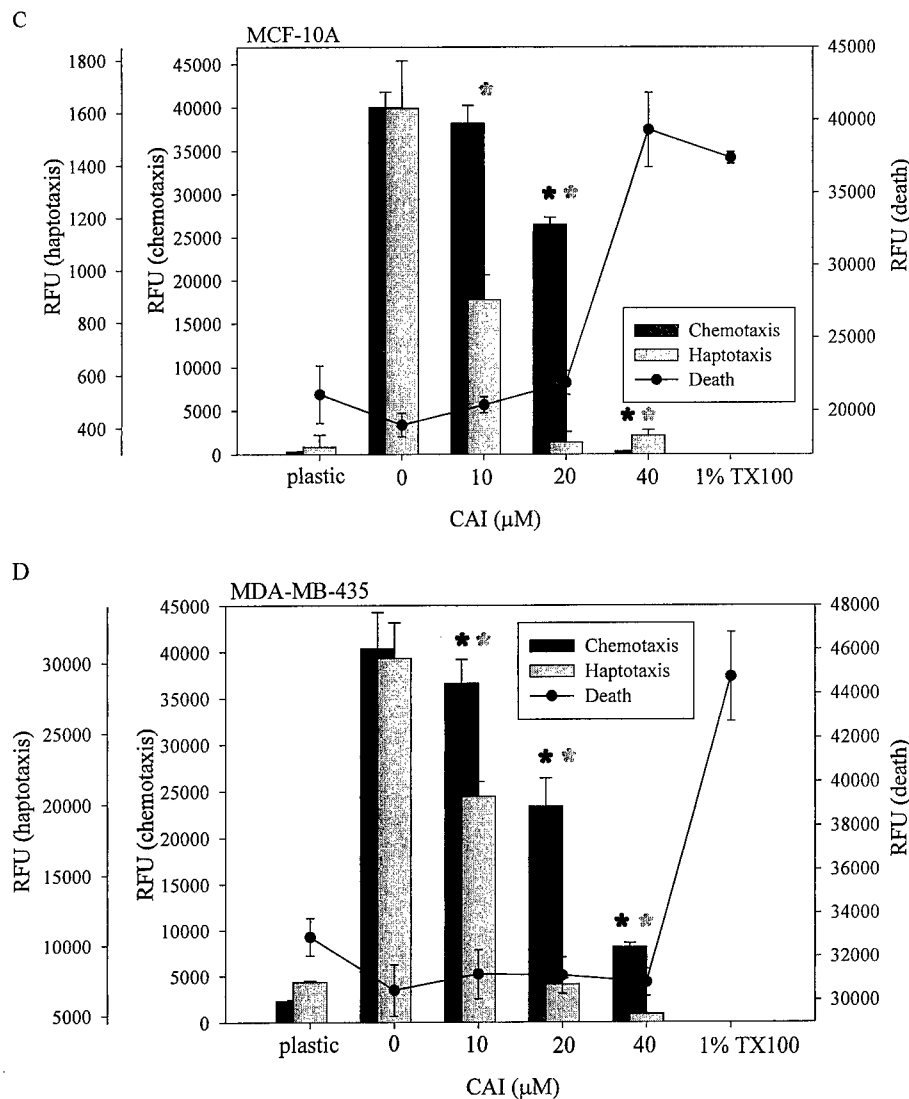

FIG. 5—Continued

the estrogen receptor (ER) (30), inhibits migration and causes cell death of ER-negative (MDA-MB-435) and ER-positive (MCF-10A) cells. This effect is not surprising since tamoxifen is shown to have an alternate mechanism for affecting antiproliferation and cytotoxicity, besides binding the estrogen receptor. In fact, ER-negative cancer patients can respond to tamoxifen while ER-positive patients can be insensitive (31). ER-negative breast cells, including MDA-MB-435 cells, have also been shown to respond to tamoxifen *in vitro* (31, 32).

The use of a fluorescence-blocking membrane suggests the possibility of measuring cell migration over time, as opposed to strictly endpoint analysis. We attempted to measure the decrease in fluorescence from the top of the filter plate and extrapolate those RFU measurements to cell number by comparison to a stan-

dard distribution of cells contained in wells of the same plate. To achieve this, the cells would have to be pre-labeled with a bright, stable dye that did not influence cell migration patterns. We assessed four classes of live-cell fluorescent dyes for these properties, calcein-AM, SP-DiOC<sub>18</sub>(3), CellTracker Blue, and carboxylate-modified fluorescent polystyrene microspheres (all purchased from Molecular Probes). Calcein-AM is a low-affinity calcium chelator (23) and inhibits migration of our cell lines, probably by interfering with calcium signaling required for migration (data not shown). These data are not surprising, as release of calcium from intracellular stores and opening of calcium channels in the plasma membrane are a consequence of integrin binding and requisite for migration under certain conditions (11, 33, 34). SP-DiOC<sub>18</sub>(3) is a lipophilic carbocyanine membrane probe that is highly fluores-

cent when incorporated into cell membranes (23). While adhesion and migration are dependent upon membrane integrity, we found that SP-DiOC<sub>18</sub>(3) did not influence migration and only subtly influenced adhesion in our cell lines (data not shown). While this dye showed promise, it exhibited less intense emission than calcein-AM and thus produced less sensitive results. In addition, while the fluorescence of this dye persisted throughout the migration assay, we found fluctuations in emission that interfered with results and were not readily explained. These fluctuations could be due to turnover of the cell membrane during the course of the assay or inherent limitations of the plate reader. CellTracker Blue is a cell-permeant thiol-reactive probe thought to produce fluorescent-glutathione adducts (23). This dye lacked the emission intensity required for these studies (data not shown). Carboxylate-modified fluorescent polystyrene microspheres offer another option for labeling migratory cells in a kinetic assay. These microspheres were spontaneously endocytosed and retained in the cytoplasm in our cell lines and do not interfere with invasion *in vivo* (35). In our assays, however, carboxylate microsphere labeling demonstrated poor reliability and sensitivity, perhaps by being processed and exocytosed from the cells before completion of the migration assay (data not shown). While these dyes are very effective in applications such as fluorescence microscopy where individual cells are visualized, they were not effective for quantifying large cell populations in kinetic migration assays.

In summary, we introduce a fluorescence-based, high-throughput assay for screening potential antimigratory compounds. With the use of two fluorescent indicators, this assay is designed to discern between cytotoxic and noncytotoxic mechanisms of action of migration-inhibiting compounds. Using this assay, we demonstrated that both the experimental anticancer compound CAI and the common breast cancer treatment tamoxifen inhibited cell migration at subcytotoxic concentrations. While MDA-MB-435 cells showed some resistance to cell death induced by high concentrations of CAI, CAI was more effective than tamoxifen at halting migration of both cell lines.

#### ACKNOWLEDGMENTS

We thank Dr. Nancy Chung-Welch, Becton Dickinson (Bedford, MA), for kindly providing 24-well fluorescence-blocking migration plates. We thank Dr. Elise C. Kohn, Laboratory of Pathology, National Cancer Institute, National Institutes of Health (Bethesda, MD), for kindly providing CAI. We also extend special thanks to Dr. Stephen W. Carper for critical reading of the manuscript and to Kilpatrick Carroll for technical assistance. This research was supported by grants from the U.S. Army (DAMD17-98-8325, to G.E.P.) and the UNLV office of sponsored programs.

#### REFERENCES

1. McKinnell, R. G., Parchment, R. E., Perantoni, A. O., and Pierce, G. B. (1998) *The Biological Basis of Cancer*, pp. 14–28, Cambridge Univ. Press, Cambridge, UK.
2. Tannock, I. F., and Hill, R. P. (1992) *The Basic Science of Oncology* (Tannock, I. F., and Hill, R. P., Eds.), pp. 302–337, McGraw-Hill, New York.
3. Kohn, E. C., and Liotta, L. A. (1995) Molecular insights into cancer invasion: Strategies for prevention and intervention. *Cancer Res.* **55**, 1856–1862.
4. Kee, J. L., and Hayes, E. R. (1997) *in Pharmacology, a Nursing Process Approach*, pp. 408–422, Saunders, Philadelphia.
5. Hahnfeldt, P., Panigrahy, D., Folkman, J., and Hlatky, L. (1999) Tumor development under angiogenic signaling: A dynamical theory of tumor growth, treatment response, and postvascular dormancy. *Cancer Res.* **59**(19), 4770–4775.
6. Gruninger, L., Cottin, E., Li, Y. X., Noel, A., Ozsahin, M., and Coucke, P. A. (1999) Sensitizing human cervical cancer cells *in vitro* to ionizing radiation with interferon beta or gamma. *Radiat. Res.* **152**(5), 493–498.
7. Guerra-Vladusic, F. K., Scott, G., Weaver, V., Vladusic, E. A., Tsai, M. S., Benz, C. C., and Lupu, R. (1999) Constitutive expression of heregulin induces apoptosis in an erbB-2 overexpressing breast cancer cell line SKBr-3. *Int. J. Oncol.* **15**(5), 883–892.
8. Lode, H. N., Moehler, T., Xiang, R., Jonczyk, A., Gillies, S. D., Cheresch, D. A., and Reisfeld, R. A. (1999) Synergy between an antiangiogenic integrin alpha antagonist and an antibody-cytokine fusion protein eradicates spontaneous tumor metastases. *Proc. Natl. Acad. Sci. USA* **96**(4), 1591–1596.
9. Price, J. T., Bonovich, M. T., and Kohn, E. C. (1997) The biochemistry of cancer dissemination. *Crit. Rev. Biochem. Mol. Biol.* **32**(3), 175–253.
10. Matsumoto, K., Ziober, B. L., Yao, C., and Kramer, R. H. (1995) Growth factor regulation of integrin mediated cell motility. *Cancer Metastasis Rev.* **14**, 205–217.
11. Lester, B. R., and McCarthy, J. B. (1992) Tumor cell adhesion to the extracellular matrix and signal transduction mechanisms implicated in tumor cell motility, invasion and metastasis. *Cancer Metastasis Rev.* **11**, 31–44.
12. Bauer, K. S., Figg, W. D., Hamilton, J. M., Jones, E. C., Premkumar, A., Steinberg, S. M., Dyer, V., Linehan, W. M., Pluda, J. M., and Reed, E. (1999) A pharmacokinetically guided Phase II study of carboxyamido-triazole in androgen-independent prostate cancer. *Clin. Cancer Res.* **5**(9), 2324–2329.
13. Lambert, P. A., Somers, K. D., Kohn, E. C., and Perry, R. R. (1997) Antiproliferative and antiinvasive effects of carboxyamido-triazole on breast cancer cell lines. *Surgery* **122**(2), 372–379.
14. Wasilenko, W. J., Palad, A. J., Somers, K. D., Blackmore, P. F., Kohn, E. C., Rhim, J. S., Wright, G. L., Jr., and Schellhammer, P. F. (1996) Effects of the calcium influx inhibitor carboxyamido-triazole on the proliferation and invasiveness of human prostate tumor cell lines. *Int. J. Cancer* **68**(2), 259–264.
15. Yangguan, W., Palad, A. J., Wasilenko, W. J., Blackmore, P. F., Pincus, W. A., Schecter, G. L., Spoonster, J. R., Kohn, E. C., and Somers, K. D. (1997) Inhibition of head and neck squamous cell carcinoma growth in invasion by the calcium influx inhibitor carboxyamido-triazole. *Clin. Cancer Res.* **3**, 1915–1921.
16. Hupe, D. J., Behrens, N. D., and Boltz, R. (1990) Anti-proliferative activity of L-651,582 correlates with calcium-mediated regulation of nucleotide metabolism at phosphoribosyl pyrophosphate synthetase. *J. Cell. Physiol.* **144**(3), 457–466.

17. Kohn, E. C., Sandeen, M. A., and Liotta, L. A. (1992) *In vivo* efficacy of a novel inhibitor of selected signal transduction pathways including calcium, arachidonate, and inositol phosphates. *Cancer Res.* **52**(11), 3208-3212.
18. Kohn, E. C., Jacobs, W., Kim, Y. S., Alessandro, R., Stetler-Stevenson, W. G., and Liotta, L. A. (1994) Calcium influx modulates expression of matrix metalloproteinase-2 (72-kDa type IV collagenase, gelatinase A). *J. Biol. Chem.* **269**(34), 21505-21511.
19. Plopper, G. E., Domanico, S. Z., Cirulli, V., Kiosses, W. B., and Quaranta, V. (1998) Migration of breast epithelial cells on Laminin-5: Differential role of integrins in normal and transformed cell types. *Breast Cancer Res. Treat.* **51**(1), 57-69.
20. Rust, W., Kingsley, K., Petnicki, T., Padmanabhan, S., Carper, S. W., and Plopper, G. E. (1999) Heat shock protein 27 plays two distinct roles in controlling human breast cancer cell migration on laminin-5. *Mol. Cell. Biol. Res. Commun.* **1**, 196-202.
21. Nieminen, A. L., Gores, G. J., Bond, J. M., Imberti, R., Herman, B., and Lemasters, J. J. (1992) A novel cytotoxicity screening assay using a multiwell fluorescence scanner. *Toxicol. Appl. Pharmacol.* **115**(2), 147-155.
22. Goldberger, A., and Septak, M. (1998) A Fluorescence Blocking Membrane Insert Enhances Analysis of Cell Motility Assays, Technical Bulletin 428, Becton Dickinson, Bedford, MA.
23. Haugland, R. P. (1996) Handbook of Fluorescent Probes and Research Chemicals, Molecular Probes, Eugene, OR.
24. Grever, M. R., Schepartz, S. A., and Chabner, B. A. (1992) The National Cancer Institute: Cancer drug discovery and development program. *Semin. Oncol.* **19**, 622-638.
25. Capsoni, F., Minonzio, F., Ongari, A. M., and Zanussi, C. (1989) A new simplified single-filter assay for "in vitro" evaluation of chemotaxis of <sup>51</sup>Cr-labeled polymorphonuclear leukocytes. *J. Immunol. Methods* **120**(1), 125-131.
26. Somersalo, K., Salo, O. P., Bjorksten, F., and Mustakallio, K. K. (1990) A simplified Boyden chamber assay for neutrophil chemotaxis based on quantitation of myeloperoxidase. *Anal. Biochem.* **185**(2), 238-242.
27. Grotendorst, G. R. (1987) Spectrophotometric assay for the quantitation of cell migration in the Boyden chamber chemotaxis assay. *Methods Enzymol.* **147**, 144-152.
28. Frevert, C. W., Wong, V. A., Goodman, R. B., Goodwin, R., and Martin, T. R. (1998) Rapid fluorescence-based measurement of neutrophil migration *in vitro*. *J. Immunol. Methods* **213**(1), 41-52.
29. Howe, A., Aplin, A. E., Alahari, S. K., and Juliano, R. L. (1998) Integrin signaling and cell growth control. *Curr. Opin. Cell Biol.* **10**, 220-231.
30. MacGregor, J. I., and Jordan, V. C. (1998) Basic guide to the mechanisms of antiestrogen action. *Pharmacol. Rev.* **50**(2), 151-196.
31. Charlier, C., Chariot, A., Antoine, N., Merville, M. P., Gielen, J., and Castronovo, V. (1995) Tamoxifen and its active metabolite inhibit growth of estrogen receptor-negative MDA-MB-435 cells. *Biochem. Pharmacol.* **49**(3), 351-358.
32. Shen, F., Xue, X., and Weber, G. (1999) Tamoxifen and genistein synergistically down-regulate signal transduction and proliferation in estrogen receptor-negative human breast carcinoma MDA-MB-435 cells. *Anticancer Res.* **19**(3A), 1657-1662.
33. Clark, E. A., and Brugge, J. S. (1995) Integrins and signal transduction pathways: The road taken. *Science* **268**, 233-239.
34. Siegel, G., Malmsten, M., and Klubendorf, D. (1998) Tumor cell locomotion and metastatic spread. *Microsc. Res. Tech.* **43**, 276-282.
35. Luzzi, K. J., MacDonald, I. C., Schmidt, E. E., Kerkvliet, N., Morris, V. L., Chambers, A. F., and Groom, A. C. (1998) Multi-step nature of metastatic inefficiency. *Am. J. Pathol.* **153**(3), 865-873.

•  
•  
•

•  
•  
•

•  
•  
•

## Antibody-Induced Activation of $\beta 1$ Integrin Receptors Stimulates cAMP-Dependent Migration of Breast Cells on Laminin-5

George E. Plopper,\*<sup>1</sup> Janice L. Huff,\* Will L. Rust,\* Martin A. Schwartz,† and Vito Quaranta‡

\*Department of Biological Sciences, University of Nevada, Las Vegas, Nevada; and †Department of Vascular Biology and ‡Department of Cell Biology, The Scripps Research Institute, La Jolla, California

Received January 8, 2001

**The  $\beta 1$  integrin-stimulating antibody TS2/16 induces cAMP-dependent migration of MCF-10A breast cells on the extracellular matrix protein laminin-5. TS2/16 stimulates a rise in intracellular cAMP within 20 min after plating. Pertussis toxin, which inhibits both antibody-induced migration and cAMP accumulation, targets the G $\alpha i 3$  subunit of heterotrimeric G proteins in these cells, suggesting that G $\alpha i 3$  may link integrin activation and migration via a cAMP signaling pathway.** © 2000 Academic Press

**Key Words:** extracellular matrix; metastasis; signal transduction.

Laminins are a diverse group of heterotrimeric extracellular matrix proteins that constitute a major component of the basement membrane of epithelial tissues. The laminin-5 isoform, consisting of the  $\alpha 3$ ,  $\beta 3$ , and  $\gamma 2$  subunits, is abundantly expressed in the basement membrane of breast tissue [1] where it plays a role in mammary branching morphogenesis, and adhesion and migration of breast epithelial cells [2].

Evidence from both *in vitro* and *in vivo* studies support a functional role for laminin-5 in cell migration of both normal and malignant breast epithelial cells. Our laboratory has previously shown that *in vitro*, laminin-5 is the preferred adhesive substrate for breast epithelial cells [1]. In haptotactic migration assays, nontumorigenic breast cell lines fail to migrate significantly on laminin-5, whereas laminin-5 supports migration of highly malignant breast cell lines. *In vivo*, laminin-5 expression is enhanced in invading regions of metastatic breast tumors [3]. In addition, an altered conformation of laminin-5, resulting from proteolytic cleavage of the  $\gamma 2$  chain by matrix metalloprotease 2, is

found at sites of tissue invasion, and this cleavage stimulates migration of otherwise nonmigratory breast cells *in vitro* [4]. Laminin-5 may contribute to the progression of tumorigenic breast cells from the stationary to malignant phenotype by stimulating enhanced migration of these cells.

Cells interact with laminins primarily through integrin receptors [5]. Ligand induced signal transduction by integrin/laminin binding regulates intracellular pH, tyrosine phosphorylation, inositol lipid metabolism, and calcium ( $Ca^{2+}$ ) oscillations [6]. Signaling molecules known to associate with integrins receptors include protein tyrosine kinases, serine/threonine kinases, phospholipid kinases and lipases, ion channels, and members of the rho family of small molecular weight GTP binding proteins [6]. Laminin-5 is recognized by the  $\alpha 3\beta 1$ ,  $\alpha 6\beta 1$ , and  $\alpha 6\beta 4$  integrin receptors in a number of cell types, and the functional consequence of these interactions depend on the integrin receptor engaged. For example, ligation of laminin-5 with the  $\alpha 6\beta 4$  integrin receptor supports branching morphogenesis and hemidesmosome formation in breast epithelial cells [2], while interaction with  $\alpha 3\beta 1$  integrin supports migration of these same cells *in vitro* [7]. Little information is currently available on the specific signaling pathways triggered during these events.

While investigating the role of the  $\alpha 3\beta 1$  integrin in motility of breast epithelial cells, we observed that haptotactic migration of the immortalized breast epithelial cell line MCF-10A on laminin-5 was stimulated by direct activation of the  $\beta 1$  integrin receptor with the  $\beta 1$ -activating monoclonal antibody TS2/16. Migration was dependent on intracellular cAMP signaling, and TS2/16-promoted a rise in intracellular cAMP levels that occurred 20 min after plating on laminin-5. Migration and cAMP accumulation were inhibited by treatment of the cells with pertussis toxin, a compound that inactivates the  $\alpha$  subunit of the inhibitory class of heterotrimeric G proteins via ADP-ribosylation. We

<sup>1</sup> To whom correspondence should be addressed at 4505 Maryland Parkway, Las Vegas, NV 89154-4004. Fax: (702) 895-3956. E-mail: [plopper@nye.nscce.edu](mailto:plopper@nye.nscce.edu).

show that the Gai3 isoform is a target for ribosylation by pertussis toxin in these cells. Together these data present evidence that the  $\beta 1$  integrin participates in the regulation of MCF-10A cell migration on laminin-5 through a cAMP-signaling pathway involving Gai3. This is the first description linking integrin activation to signaling through heterotrimeric G proteins.

## MATERIALS AND METHODS

### Cells

MCF-10A cells were maintained in DFCI medium according to Band and Sager [8]. MDA-MB-231 cells were cultured as described [1]. Rat 804G cells were maintained in Dulbecco's Modified Eagle Medium (DMEM) containing 10% fetal calf serum and  $1 \times$  Glutamine Pen-Strep solution (Irving Scientific). 804G cell conditioned medium was collected after 3 days of culturing and was clarified by centrifugation at 1500g.

### Reagents

Mouse monoclonal antibodies against human integrin  $\alpha 3$  (clone PIB5) and  $\beta 1$  (Clone P4C10) were purchased from Gibco (Gaithersburg, MD). Mouse monoclonal antibody clone P5D2 against human  $\beta 1$  integrin was purchased from Chemicon (Temecula, CA). Purified rat anti-mouse  $\beta 1$  antibody 9EG7 was purchased from Pharmingen (San Diego, CA), and dialysed against PBS to remove sodium azide. Mouse monoclonal anti-human, activating  $\beta 1$  integrin antibody TS2/16 (in ascites form) was generously provided by Dr. Martin Hemler (Dana Farber Cancer Institute, Boston, MA). Anti-rat laminin-5 monoclonal antibody TR1 was produced in this laboratory [9]. Both TS2/16 and TR1 were purified with a protein G affinity chromatography kit (Pierce, Rockland, IL). SQ22536 was purchased from Biomol (Plymouth Meeting, PA) and pertussis toxin from List Biological Laboratories, Inc. (Campbell, CA). 8-Bromo-cAMP, dibutryl cAMP, H-89, and forskolin were purchased from Calbiochem (San Diego, CA).

### Adhesion and Migration Assays

Adhesion and migration assays were performed as previously described [1]. For anti-integrin antibody blocking experiments, antibodies were incubated with cells for 30 min before adding to assay wells, and were present throughout the assays.

### cAMP Determination

Cells were collected by brief trypsinization, blocked with trypsin inhibitor, washed in DMEM, counted, resuspended at  $1 \times 10^6$  cells/ml, and incubated at 37°C in migration medium/1 mM isobutylmethylxanthine (Sigma) to block phosphodiesterase activity. After 30

min, anti-integrin antibodies (TS2/16 or P5D2) were added, and cells were incubated at 37°C for an additional hour. Control cells were suspended in DMEM/1 mM isobutylmethylxanthine alone during this time. Cells ( $1 \times 10^6$ /plate) were then plated on 35-mm dishes coated with affinity-captured laminin-5 [1] and incubated at 37°C for the indicated times. Cells representing the 0 time point were immediately retrieved from the dishes, collected by centrifugation, and lysed in cold cAMP extraction solution (95% ethanol, 5% 0.1 N HCl). After 10, 20, 30, and 90 min nonadherent cells were aspirated, plates were washed with PBS, and cAMP extraction buffer was added to the adherent cells. The PBS washes from each plate were centrifuged to collect loosely adherent cells, and these were added back to the appropriate extraction. All samples were kept on ice in cAMP extraction buffer for 2 h, then centrifuged to pellet precipitated protein. Protein was dissolved in 0.1 N NaOH and concentrations were determined with the BCA microassay (Pierce). Supernatants were evaporated and cAMP measured using a cAMP EIA kit (Perseptive Diagnostics, Inc., Cambridge, MA) as directed by the manufacturer. cAMP amounts were normalized to total protein in each sample and expressed as fmol/ $\mu$ g protein.

### ADP Ribosylation Assay

**Membrane preparation.** Membranes were isolated from MCF-10A cells by lysis in ice-cold 10 mM Hepes pH 7.5, 3 mM MgCl<sub>2</sub>, 2 mM EDTA containing 10  $\mu$ g/ml leupeptin, 2  $\mu$ g/ml aprotinin, and 0.5 mg/ml Pefabloc SC (Boehringer Mannheim Biochemicals, Indianapolis, IN). Cells were scraped, centrifuged to pellet nuclei, and the supernatant was collected. Membranes were pelleted from supernatant by centrifugation at 13,000g for 30 min at 4°C; and the pellets were resuspended in lysis buffer. Protein concentrations were determined by BCA protein assay (Pierce).

**ADP-ribosylation and immunoprecipitation.** ADP-ribosylation reactions were performed as described [10]. Final reaction conditions were as follows: 100  $\mu$ g membrane protein was suspended in 20 mM thymidine, 1 mM ATP, 1 mM GTP, 1 mM EDTA, 20 mM Hepes, pH 7.5 with or without 7.5  $\mu$ g pertussis toxin (activated prior to experiment by incubation for 10 min at 37°C in 20 mM DTT, 20 mM Hepes, pH 7.5) and 25  $\mu$ Ci <sup>32</sup>P-NAD (Specific activity = 30 Ci/mM, New England Nuclear catalog #BLU023). Reactions proceeded for 45 min at 30°C and were stopped by chilling to 4°C followed by a wash with 20 mM Hepes pH 7.5, 1 mM EDTA and 1 mM DTT. For SDS-PAGE analysis, membranes were solubilized in 50  $\mu$ l Laemmli sample buffer (LSB), heated for 5 min at 100°C and separated on a 12% SDS-polyacrylamide gel. <sup>32</sup>P-labeled proteins were detected by autoradiography of dried gels using Kodak X-Omat AR film with intensifying screens. For

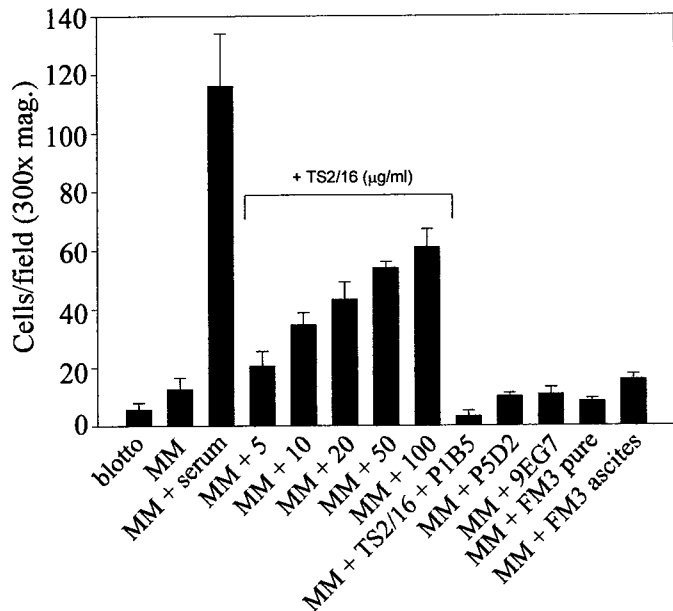

**FIG. 1.** The integrin activating antibody TS2/16 stimulates migration of MCF-10A breast cells on laminin-5. Indicated concentrations of TS2/16 were added to MCF-10A cells in a minimal medium lacking serum or other growth factors (MM) 15 min prior to plating in laminin-5 migration assays, and migrated cells were counted 18 h later. As controls, cells were plated in the presence of 10% serum, irrelevant mouse ascites (FM3 ascites), antibody purified from irrelevant ascites (FM3 pure), or nonfat dried milk (blotto). Results are expressed as the mean of eight measurements on two filters using 300 $\times$  magnification,  $\pm$  standard deviation.

immunoprecipitations, ribosylated membrane proteins were solubilized in RIPA buffer containing protease inhibitors and were incubated with the following G-protein  $\alpha$  subunit-specific peptide antibodies: I-20, specific for  $G_{\alpha i1}$ ; C-10, specific for  $G_{\alpha i3}$  (Santa Cruz Biotechnology). Immune complexes were captured by incubation with A/G agarose (Santa Cruz Biotechnology), solubilized by boiling in LSB and analyzed by SDS-PAGE as described.

## RESULTS AND DISCUSSION

### *The $\beta 1$ Integrin-Activating Antibody TS2/16 Stimulated MCF-10A Migration on Laminin-5*

The nontumorigenic breast cell MCF-10A remains statically adherent to laminin-5 via the  $\alpha 3 \beta 1$  integrin [1]. In haptotactic Transwell filter migration assays, these cells demonstrated only modest migration towards laminin-5. When preincubated with TS2/16, however, MCF-10A cells increased their migration in a dose-dependent manner towards laminin-5 (Fig. 1). TS2/16-treated cells also exhibited increased adhesion to laminin-5 (Fig. 2). These effects are not observed with other  $\beta 1$  targeting antibodies (P5D2, 9EG7, Fig. 1; 9EG7, Fig. 2) or with TS2/16 on other substrates (data not shown). TS2/16 therefore stimulated a signaling

pathway that, concurrent with laminin-5 binding, led to enhanced cell migration. This pathway is dependent upon binding of the  $\alpha 3 \beta 1$  integrin, as pretreatment of the cells with the  $\alpha 3$  integrin-blocking antibody P1B5 completely blocked TS2/16-stimulated migration on laminin-5 (Fig. 1).

In each experiment, maximum stimulation of cell migration was observed when cells were allowed to migrate towards a gradient of fetal calf serum. This control was included in each migration assay to indicate the dynamic range of migration response in each population of cells. It is likely that this chemotactic migration was stimulated by the growth factors present in fetal calf serum, as serum-induced migration was inhibited by greater than 80% when cells were preincubated with antibodies that block the function of the epidermal growth factor receptor or drugs that inhibit tyrosine kinases (G. E. Plopper, unpublished data). It is therefore likely that serum was a stronger promigratory stimulant than TS2/16 because it activated several signaling pathways stimulated by soluble growth factors, while TS2/16 targeted integrin-associated signaling pathways.

The strength of cell adhesion to extracellular matrix ligands varies over a wide range and is under the control of both intracellular and extracellular cues. Work by Lauffenburger [11] suggests that very tight or very loose cell adhesion to matrix proteins will not support cell migration, and that migration occurs only when a medium-strength of adhesion is achieved. Thus, varying the potency of adhesion of integrin receptors for their ligands may be a critical step for

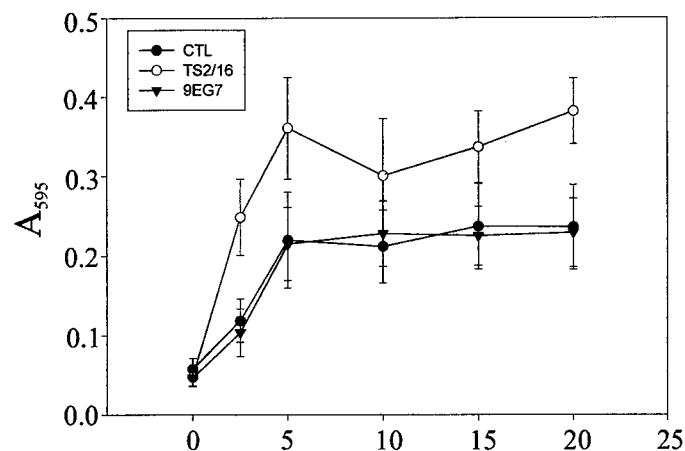

**FIG. 2.** TS2/16 antibody increases adhesion of MCF-10A cells to laminin-5. Cells were incubated in MM with 50  $\mu\text{g}/\text{ml}$  of TS2/16 or 9EG7 antibodies for 15 min, then were plated on affinity-captured laminin-5 for 30 min and adhesion quantified by measuring absorbance of crystal violet-dyed cells at 595 nm. Affinity capture was accomplished by successive addition of indicated concentrations of TR1 antibody, blotto, and 804G-conditioned medium containing soluble laminin-5. As a control (CTL), cells were incubated with no antibodies prior to plating. Results expressed as statistical mean  $\pm$  standard deviation ( $n = 8$ ).

regulating cell migration. It is possible that TS2/16 stimulated migration in these cells by changing the strength of adhesion between  $\alpha 3\beta 1$  integrin and laminin-5, either directly or via activation of internal signaling pathways.

Alternatively, it is plausible that TS2/16 induced a conformational change in the  $\beta 1$  integrin that mimicked binding to a promigratory form of laminin-5, such as those created through proteolytic processing. For example, cleavage of the  $\gamma_2$  subunit of laminin-5 creates a conformation on which MCF-10A cells migrate constitutively [4, 12]. A promigratory laminin-5 can be converted to one that inhibits cell migration through cleavage of the  $\alpha 3$  chain [13]. In both instances it is assumed that proteolytic processing masks or unmasks a promigratory domain on the intact laminin-5 trimer. This theory is also supported by studies showing that integrin activation by TS2/16 will rescue the growth of MCF-10A cells inhibited by treatment with laminin-5 blocking antibodies [14].

#### MCF-10A Cell Migration on Laminin-5 Is Modulated by cAMP

To define the mechanisms by which TS2/16 stimulated MCF-10A cell migration on laminin-5, we added inhibitors of known signaling molecules to antibody-stimulated cells in haptotaxis migration assays. We found that SQ22536, an inhibitor of adenylate cyclase,

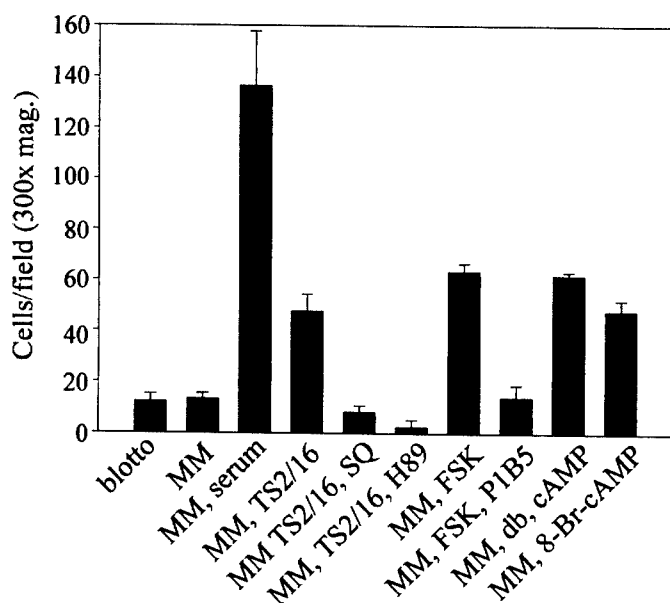

**FIG. 3.** Enhanced cAMP levels induce migration of MCF-10A cells on laminin-5. Cells were incubated in MM supplemented with 50  $\mu\text{g/ml}$  TS2/16, 50  $\mu\text{g/ml}$  PIB5, 250 mM SQ22536 (SQ), 4  $\mu\text{M}$  H89, 5 nM forskolin (FSK), 500  $\mu\text{M}$  dibutyryl cAMP (db cAMP), or 500  $\mu\text{M}$  8-bromo-cAMP (8-Br-cAMP) for 15 min prior to adding to laminin-5 migration assays. As a control, cells were plated in the presence of serum or in MM on filters lacking laminins (blotlo). Results are expressed as in Fig. 1.

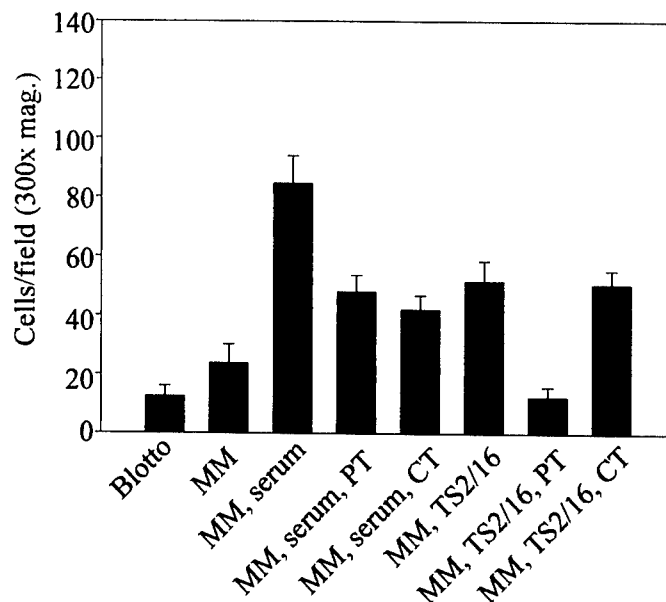

**FIG. 4.** Pertussis toxin inhibits TS2/16-stimulated migration on laminin-5. MCF-10A cells were suspended for 30 min in MM supplemented with either 10% serum or 50  $\mu\text{g/ml}$  TS2/16. 100 ng/ml pertussis toxin (PT), 100 ng/ml cholera toxin (CT), were added 15 min prior to plating cells in laminin-5 migration assays. As a control, cells suspended in MM were added to filters coated with blotlo alone. Results expressed as in Fig. 1.

and H-89, an inhibitor of cAMP dependent protein kinase, completely blocked TS2/16 stimulated migration on laminin-5 (Fig. 3). In addition, pharmacological enhancement of cAMP levels with either forskolin or the nonhydrolyzable cAMP analogs 8-bromo-cAMP and dibutyryl cAMP were sufficient to enhance migration of MCF-10A cells on laminin-5 to levels stimulated by TS2/16 (Fig. 3). Prolonged (18 h) exposure to pertussis toxin, a compound that inhibits the cAMP signaling pathway mediated by the  $G_{\alpha i}$  class of signaling proteins, abolished migration on laminin-5 (Fig. 4) and reduced cAMP levels in MCF-10A cells over the same time course (Fig. 5B). These data established that cAMP was required for enhanced migration of MCF-10A cells on laminin-5.

Because adenylate cyclase activity is governed by different classes of heterotrimeric G proteins we exposed MCF-10A cells to pertussis toxin (an inhibitor of the  $G_{\alpha i}$  class) and cholera toxin (an inhibitor of the  $G_{\alpha s}$  class). While both pertussis and cholera toxin partially blocked serum stimulated migration of MCF-10A cells (approximately 50%), only pertussis toxin blocked TS2/16 stimulated migration on laminin-5 (Fig. 4). These data demonstrated that the specific pathway triggered by TS2/16 and laminin-5 was susceptible to regulation by  $G_{\alpha i}$  rather than  $G_{\alpha s}$  proteins, and again suggest that serum-stimulated migration resulted from activation of multiple signaling pathways, some of which utilize cAMP as a second messenger.

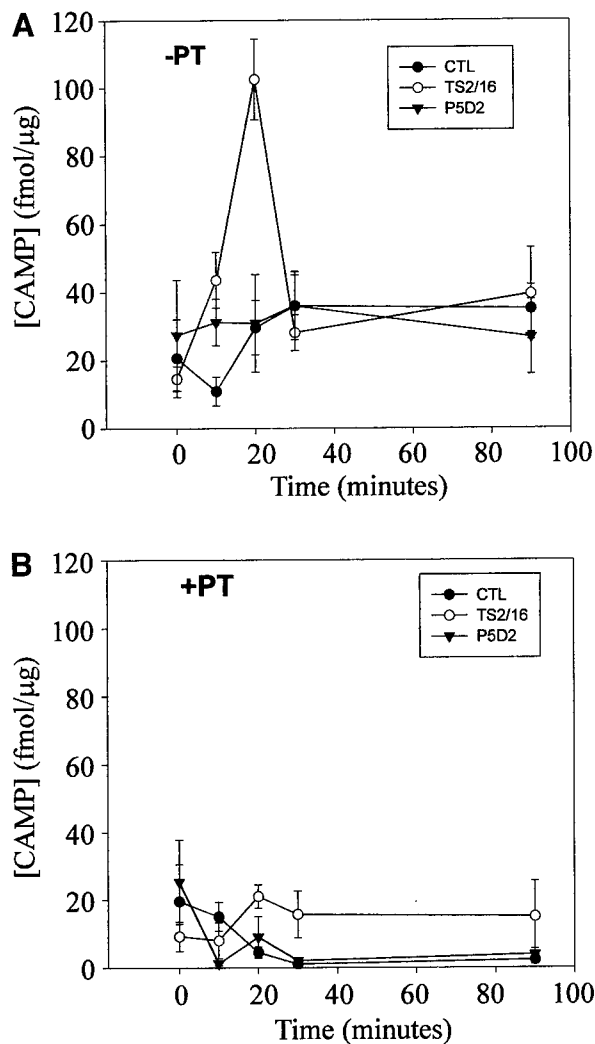

**FIG. 5.** Pertussis toxin inhibits a cAMP peak in TS2/16-stimulated cells. MCF-10A cells were suspended in MM supplemented with 20  $\mu\text{g/ml}$  TS2/16 or P5D2 antibodies and plated on laminin-5 for the indicated time, then lysed and assayed for total cAMP content by ELISA assay. As a control, cells were plated in the absence of antibodies (CTL). The experiments were performed (A) in the absence (-PT) or (B) presence (+PT) of 100 ng/ml pertussis toxin. Results are normalized to total cell protein for each time point and represent the mean of triplicate measurements for four experiments,  $\pm$  the standard error of the means.

Not all compounds that induced a rise in cAMP stimulated migration on laminin-5. Cholera toxin induced a transient rise in cAMP in MCF-10A cells (G. E. Plopper, unpublished observations), and stimulated growth of these cells when used in small quantities (ng/ml) in the low-serum media for these cells (DFCI medium) [8]. It is generally thought that small quantities of cholera toxin stimulate growth in these cells by activating signaling pathways used by G protein-linked chemokines (Gary Bokoch, Department of Immunology, The Scripps Research Institute, personal communication). Higher concentrations of cAMP ( $\mu\text{g/ml}$ ) typically used to irreversibly activate *G $\alpha$ s* did not

stimulate haptotactic migration of MCF-10A cells on laminin-5 (G. E. Plopper, unpublished observations), suggesting that while cholera toxin does affect signaling in these cells, the pathways it affects do not play a role in integrin activated migration on laminin-5.

Chemotactic migration of many cell types is inhibitable by cholera and pertussis toxins [15, 16]. While pertussis toxin allows for unchecked cAMP production in the short term, prolonged pertussis toxin exposure suppressed cAMP levels in our cells, likely because of long-term desensitization of this pathway [17]. Although O'Conner *et al.* [18] reported that  $\alpha 6\beta 4$  expression suppressed cAMP levels in migrating breast cancer cells, no evidence has been published linking cholera and pertussis-sensitive signaling pathways to integrin-activated signaling.

These findings are consistent with our observation that numerous chemokines that modulate cAMP through *G $\alpha$ s* (bombesin, bradykinin, adrenaline) raised cAMP levels but failed to stimulate migration in our cells (G. E. Plopper, unpublished data). Each of these compounds exerts very distinct responses in breast cells, suggesting that while they share cAMP as a second messenger, they must generate specificity elsewhere in their signaling pathways. The specificity necessary to modulate haptotactic migration may be generated by localizing cAMP bursts to specific times and/or locations within a cell, by targeting specific isoforms of adenylate cyclase, or by integrating cAMP bursts with other integrin-associated behaviors (e.g., formation of focal adhesions, generation of cellular tension, activation of signaling pathways linked to migration in other cell types [e.g., those that utilize rho/ras G proteins or focal adhesion kinase]) [19].

Indeed, such integration appears to take place in smooth muscle cells, which exhibit increased migration on collagen upon activation of a cAMP signaling pathway linked to integrin associated protein and  $\alpha 2\beta 1$  integrin; this activation also stimulates the mitogen activated protein kinase ERK, and is inhibited by pertussis toxin. [20]. In this study, migration is stimulated upon a reduction in cAMP levels and is inhibited by analogs of cAMP. The differences between these findings and ours may be attributed to differences in cell type, migratory stimulus, migratory substrate, and/or integrin receptor involved: we have observed that inhibition of  $\alpha 2\beta 1$  integrin stimulates haptotactic  $\alpha 3\beta 1$ -mediated migration in our cells, for example (G. E. Plopper, unpublished findings).

#### *TS2/16 Stimulated a Rise in Intracellular cAMP via a Pertussis Toxin-Sensitive Signaling Pathway*

Since pertussis toxin alters intracellular cAMP levels, and cAMP modulation was sufficient to enhance migration in our cells, we examined the levels of cAMP in TS2/16-stimulated cells plated on

laminin-5. Within 20 min after plating, cAMP levels were raised approximately fourfold in TS2/16 treated cells. This peak occurred within the time frame of integrin signaling [6]. Enhanced cAMP accumulation was specific to TS2/16, and not a product of integrin clustering, as neither cells treated with the nonactivating  $\beta 1$  antibody P5D2 nor cells plated on laminin-5 without antibodies exhibited enhanced cAMP production (Fig. 5A). Preincubation with pertussis toxin completely eliminated this peak but did not significantly affect basal cAMP levels (Fig. 5B). Concurrent stimulation by laminin-5 adhesion and TS2/16 are required, as cAMP levels did not change in suspended cells treated with TS2/16 (G. E. Plopper, unpublished). It appeared, therefore, that the combination of intact laminin-5 and TS2/16 pretreatment stimulated a signaling pathway involving cAMP that was specifically blocked by pertussis toxin.

#### *Pertussis Toxin ADP-Ribosylated Gai3 in MCF-10A Cells*

Pertussis toxin ADP ribosylates the Gai class of heterotrimeric G proteins. To determine the repertoire of Gai subunits expressed in MCF-10As we performed Western blot analysis of whole cell lysates and isolated membrane fractions using polyclonal antibodies raised against specific G protein subunits. These studies revealed that MCF-10A cells expressed Gai1 and Gai3, but not Gai2 (data not shown). To establish the targets of pertussis toxin in these cells we carried out ADP-ribosylation assays in the presence of  $^{32}\text{P}$ -NAD. Addition of pertussis toxin specifically induced the ribosylation of a 43-kDa protein (Fig. 6, lane 2). No  $^{32}\text{P}$  labeled proteins are detectable without addition of pertussis toxin (Fig. 6, lane 1). The molecular weight of the ribosylated protein was consistent with that of the  $\alpha$  subunits of heterotrimeric G proteins. The identity of this protein was determined by immunoprecipitation of the ribosylated membrane proteins with Gai1 and Gai3 antibodies. Antibody C10, which reacts primarily with Gai3, immunoprecipitated a band of 43 kDa (Fig. 6, lane 4). The anti-Gai1 antibody I-20 failed to precipitate any ADP ribosylated proteins in MCF-10A cells (Fig. 6, lane 3), but did precipitate a 43-kDa band from a control cell line, MDA-MB-231 (Fig. 6, lane 5). Therefore, pertussis toxin ribosylated Gai3, but not Gai1 in MCF-10A cells.

In addition to controlling adenylate cyclase activity, Gai3 is associated with and activates amiloride-sensitive  $\text{Na}^+$  channels [21], which are expressed in many epithelial cells including breast. These channels are also regulated by the actin cytoskeleton [22] and cAMP dependent protein kinase [23], suggesting that Gai3 may link integrin-mediated actin polymerization, cAMP signaling, cAMP dependent protein kinase ac-

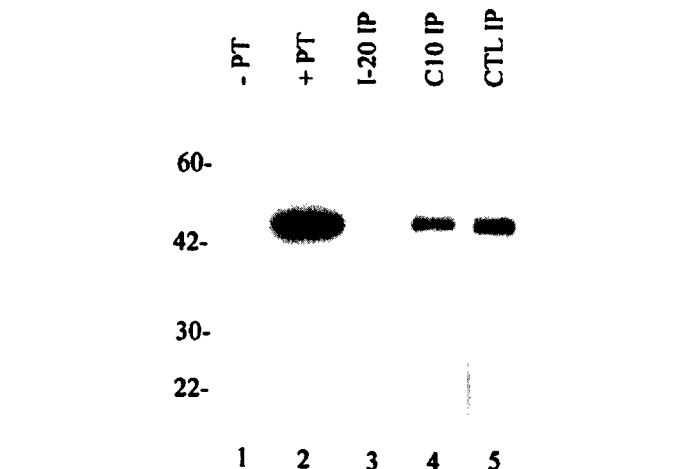

**FIG. 6.** Pertussis toxin specifically ADP ribosylates Gai3 in MCF-10A cells. 100  $\mu\text{g}$  of cell membranes were incubated with 25  $\mu\text{Ci}$   $^{32}\text{P}$ -NAD in the presence (lanes 2–4) or absence (lane 1) of 7.5  $\mu\text{g}$  activated pertussis toxin. Pertussis toxin-treated lysates were immunoprecipitated with anti-Gai1 (I-20, lane 3) or anti-Gai3 (C10, lane 4) antibodies. As a control, Gai1 was immunoprecipitated from  $^{32}\text{P}$ -NAD labeled lysates of pertussis toxin-treated MDA-MB-231 cells (CTL, lane 5). Migration of molecular weight standards is shown at left.

tivity, and amiloride-sensitive channel activation. Curiously, amiloride also suppresses lung metastases from breast tumors [24]; our data suggest that it may do so, at least in part, by inhibiting tumor cell migration.

In conclusion, we report that the  $\beta 1$  integrin-stimulating antibody TS2/16 induced migration of MCF-10A cells on laminin-5 that was dependent upon cAMP linked signaling. TS2/16 also stimulated a rise in intracellular cyclic AMP within 20 min after plating on laminin-5. Both the enhanced migration and cAMP peak were inhibited by pertussis toxin. Pertussis toxin targeted the Gai3 subunit of heterotrimeric G proteins in these cells. This evidence suggests that the  $\beta 1$  integrin participates in the control of MCF-10A cell migration on laminin-5 via a cAMP signal pathway regulated by Gai3. This form of signaling, beginning with an external stimulus of the integrin receptor, is referred to as “outside-in signaling” to differentiate it from changes in integrin function resulting from activation of internal signaling pathways [6]. We propose that TS2/16 mimics the effects of proteolytic processing of laminin-5 by forcing the  $\alpha 3\beta 1$  integrin into a conformation formed by binding promigratory forms of laminin-5. We are currently examining the effect of these proteolytic modifications on intracellular signaling activities in MCF-10A cells. Because acquisition of a migratory phenotype is required for malignant progression of tumorigenic breast cells, elucidating pathways involved in enhanced migration of breast may lead to discovery of novel targets for anticancer therapies.

## ACKNOWLEDGMENTS

This work was supported by the following grants: U.S. Army Breast Cancer Research Program Career Development Award BC971342, grants from the UNLV Office of Sponsored Programs to G.E.P., and National Institutes of Health (GM46902) to V.Q.

## REFERENCES

- Plopper, G. E., Domanico, S. Z., Cirulli, V., Kiosses, W. B., and Quaranta, V. (1998) *Breast Cancer Res. Treat.* **51**, 57-69.
- Stahl, S., Weitzman, S., and Jones, J. (1997) *J. Cell Sci.* **110**, 55-63.
- Pyke, C., Salo, S., Ralfkiaer, E., Romer, J., Dano, K., and Trygvason, K. (1995) *Cancer Res.* **55**, 4132-4139.
- Giannelli, G., Falk-Marzillier, J., Schiraldi, O., Stetler-Stevenson, W. G., and Quaranta, V. (1997) *Science* **277**, 225-228.
- Guan, J. L., and Chen, H. C. (1996) *Int. Rev. Cytol.* **168**, 81-121.
- Schwartz, M. A., Schaller, M. D., and Ginsberg, M. H. (1995) *Annu. Rev. Cell Dev. Biol.* **11**, 549-599.
- Carter, W. G., Kaur, P., Gil, S. G., Gahr, P. J., and Wayner, E. A. (1990) *J. Cell Biol.* **111**, 3141-3154.
- Band, V., and Sager, R. (1989) *Proc. Natl. Acad. Sci. USA* **86**, 1249-1253.
- Plopper, G., Falk-Marzillier, J., Glaser, S., Fitchmun, M., Giannelli, G., Romano, T., Jones, J. C., and Quaranta, V. (1996) *J. Cell Sci.* **109**, 1965-1973.
- Sebok, K., Woodside, D., al-Aoukaty, A., Ho, A. D., Gluck, S., and Maghazachi, A. A. (1993) *J. Immunol.* **150**, 1524-1534.
- Lauffenburger, D. A., and Horwitz, A. F. (1996) *Cell* **84**, 359-369.
- Falk-Marzillier, J., Jones, J. C., and Fitchmun, M. (1998) *Mol. Biol. Cell* **9**, 169a (Abstract).
- Goldfinger, L. E., Stack, M. S., and Jones, J. C. (1998) *J. Cell Biol.* **141**, 255-265.
- Gonzales, M., Haan, K., Baker, S. E., Fitchmun, M., Todorov, I., Weitzman, S., and Jones, J. R. (1999) *Mol. Biol. Cell* **10**, 259-270.
- Hauzenberger, D., Klominek, J., and Sundqvist, K. G. (1994) *J. Immunol.* **153**, 960-971.
- Aznavoorian, S., Stracke, M. L., Parsons, J., McClanahan, J., and Liotta, L. A. (1996) *J. Biol. Chem.* **271**, 3247-3254.
- Reithmann, C., Gierschik, P., Werdan, K., and Jakobs, K. H. (1991) *Mol. Cell Endocrinol.* **82**, C215-C221.
- O'Connor, K. L., Shaw, L. M., and Mercurio, A. M. (1998) *J. Cell Biol.* **143**, 1749-1760.
- Horowitz, A. R., and Parsons, J. T. (1999) *Science* **286**, 1102-1103.
- Wang, X. Q., Lindberg, F. P., and Frazier, W. A. (1999) *J. Cell Biol.* **147**, 389-399.
- Ausiello, D. A., Stow, J. L., Cantiello, H. F., de Almeida, J. B., and Benos, D. J. (1992) *J. Biol. Chem.* **267**, 4759-4765.
- Cantiello, H. F. (1995) *Kidney Int.* **48**, 970-984.
- Prat, A. G., Bertorello, A. M., Ausiello, D. A., and Cantiello, H. F. (1993) *Am. J. Physiol.* **265**, C224-C233.
- Evans, D. M., Sloan-Stakleff, K., Arvan, M., and Guyton, D. P. (1998) *Clin. Exp. Metastasis* **16**, 353-357.

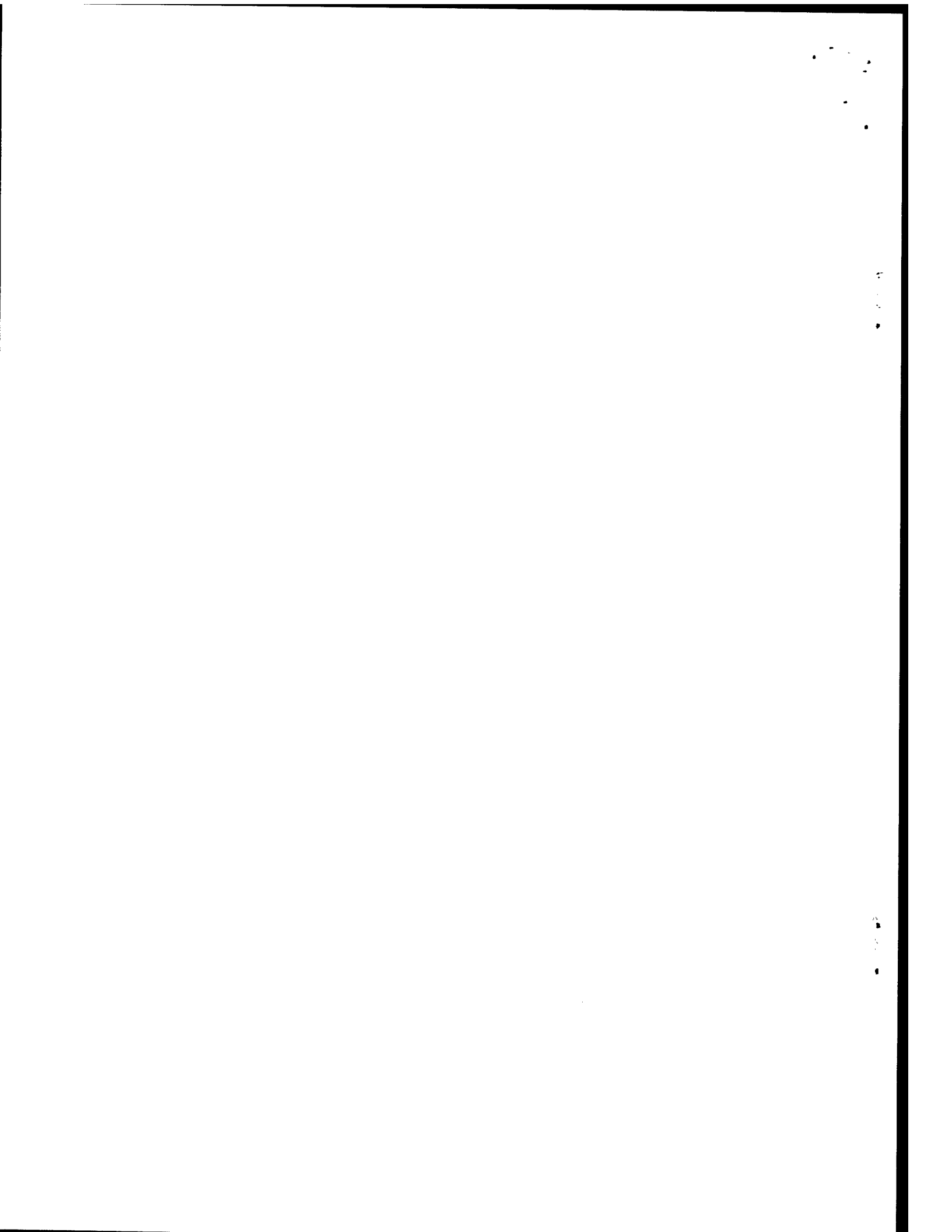

# The WD protein Rack1 mediates protein kinase C and integrin-dependent cell migration

Charito S. Buensuceso<sup>1</sup>, Darren Woodside<sup>1</sup>, Janice L. Huff<sup>2</sup>, George E. Plopper<sup>2</sup> and Timothy E. O'Toole<sup>1,\*</sup>

<sup>1</sup>Department of Vascular Biology, Scripps Research Institute-VB2, 10550 N. Torrey Pines, La Jolla, CA 92037, USA

<sup>2</sup>Department of Biology, University of Nevada, Las Vegas, USA

\*Author for correspondence (e-mail: totoole@alumni.umich.edu)

Accepted 16 February 2001

Journal of Cell Science 114, 1691-1698 © The Company of Biologists Ltd

## SUMMARY

The scaffolding protein, Rack1, is a seven-WD-domain-containing protein that has been implicated in binding to integrin  $\beta$  subunit cytoplasmic domains and to members of two kinase families (src and protein kinase C, PKC) that mediate integrin bidirectional signaling. To explore the role of Rack1 in integrin function we have transfected this protein in Chinese hamster ovary (CHO) cells. We have observed no effect of Rack1 overexpression on inside-out signaling as the ligand binding properties of CHO cells also expressing constitutively active or inactive integrins were not affected. In contrast, we observed that cells stably or transiently overexpressing Rack1 had decreased migration compared to mock transfected cells. Stable Rack1 transfectants also demonstrated an increased number of

actin stress fibers and focal contacts. These effects on motility and cytoskeletal organization did not appear to result from Rack1 inhibition of src function as downstream substrates of this kinase were phosphorylated normally. In addition, expression of an active src construct did not reverse the migratory deficit induced by Rack1 overexpression. On the other hand when we overexpressed a Rack1 variant with alanine substitutions in the putative PKC binding site in its third WD domain, we observed no deficit in migration. Thus the ability of Rack1 to bind, localize and stabilize PKC isoforms is likely to be involved in aspects of integrin outside-in signaling.

Key words: Rack1, Migration, Integrin, Protein kinase C

## INTRODUCTION

The orderly and controlled migration of cells is crucial in many aspects of physiology including embryonic development, immune function, wound repair and angiogenesis. Unregulated or abnormal cell motility also underscores certain pathological situations such as the invasion and metastasis of cancer cells. Cell migration is a complex response to external stimuli involving an interplay between cellular adhesive events and cytoskeletal organization. Signal transduction events involving the regulation of integrin affinity (Huttenlocher et al., 1996), small GTPases (Nobes and Hall, 1995; Nobes and Hall, 1999; Takaishi et al., 1993), the ras/MAP kinase pathway (Klemke et al., 1997; Nguyen et al., 1999), Cas/Crk coupling (Klemke et al., 1998), focal adhesion kinase (Cary et al., 1996; Ilic et al., 1995), phosphatidylinositol 3-kinase (Rodriguez-Vicana et al., 1997), PLC $\gamma$  (Chen et al., 1994), protein kinase C (Laudanna et al., 1998; Ng et al., 1999; Rigot et al., 1998) and calpain (Huttenlocher et al., 1997), have all been implicated in regulating integrin-mediated adhesion, integrin downstream signaling or actin polymerization leading to motile behavior. Understanding the molecular events that regulate cell migration will be important in designing ways to control this event.

Rack1 is a 36 kDa cytosolic protein composed of seven WD motifs and thus is structurally similar to a G protein  $\beta$  subunit. It was originally identified as a receptor for activated protein kinase C (Ron et al., 1994). In this mode of action, Rack1 acts as neither a substrate nor an inhibitor, but rather enables the

translocation of PKC isozymes and stabilizes their active forms (Mochly-Rosen and Gordon, 1998). Indeed, reduced Rack1 levels are correlated with defective PKC translocation in the aging rat brain (Battaini et al., 1997) and disruption of PKC-Rack1 interactions impaired insulin-induced kinase translocation, *Xenopus* oocyte maturation (Ron et al., 1995) and regulation of calcium channels in cardiomyocytes (Zhang et al., 1997). Rack1 has also been isolated in a yeast two-hybrid screen using an src SH2 domain as bait (Chang et al., 1998). Additional studies suggested that the interaction of Rack1 with src family members inhibited the activity of these kinases in vitro and that Rack1 overexpression in NIH 3T3 and 293T cells decreased growth rates and levels of tyrosine-phosphorylated proteins, respectively (Chang et al., 1998). Thus, Rack1 appeared to have opposing effects on the kinases to which it binds: stabilizing the active conformation of PKC but inhibiting members of the src family. Additional binding partners of Rack1 include integrin  $\beta$  subunit cytoplasmic domains (Liliental and Chang, 1998; Zhang and Hemler, 1999), a phosphodiesterase isoform (Yarwood et al., 1999), certain pleckstrin homology (PH) domains (Rodriguez et al., 1999) and the common  $\beta$  chain of the IL-5/IL-3/GM-CSF receptor (Geijsen et al., 1999). While the functional significance of these latter associations remains undefined, a role for Rack1 as a scaffolding protein is suggested.

Since PKC and src family kinases have been implicated in integrin bidirectional signaling, we wished to explore the functional consequences of Rack1-integrin association. When transiently or stably overexpressed in CHO cell lines, Rack1

did not appear to affect ligand binding properties. However these transfectants did demonstrate decreased integrin-dependent cell migration and an increased number of actin stress fibers and focal contacts compared to wild-type cells. These effects did not appear to be due to inhibition of src kinase activity and were not reversed with an active src construct. In addition, these migratory defects were not observed when we utilized a Rack1 construct with a mutated PKC binding site. These results suggest that Rack1 is involved in integrin outside-in signaling in a manner that involves its interaction with PKCs but is independent of its reported effects on src.

## MATERIALS AND METHODS

### Reagents

A monoclonal antibody against Rack1 was obtained from Transduction Labs while one against talin was from Sigma. An  $\alpha_{11b}\beta_3$  antibody (D-57) and the ligand mimetic monoclonal, Pac1, were obtained from Mark Ginsberg and Sandy Shattil, Scripps Research Institute, respectively. All other antibodies (HA epitope, crk, cas, ERK1 and ERK2, phospho-ERK and phosphotyrosine) were from Santa Cruz Biotechnologies. The conjugated reagents, phycoerythrin-streptavidin and FITC-IgG and IgM were from Molecular Probes and Biosource, respectively. The calcein AM dye and rhodamine-phalloidin were obtained from Molecular Probes while matrix proteins were from Enzyme Research Laboratories Inc. Restriction enzymes were from New England Biolabs or Boehringer Mannheim. All synthetic oligonucleotides were from Genosys.

### cDNA cloning

A partial cDNA for Rack1 encoding residues 81-317 was isolated in a yeast two-hybrid screen using a HeLa cell library and the  $\beta_1$  tail as a bait. Two-hybrid screening, yeast manipulations and liquid  $\beta$ -galactosidase assays were done as per the manufacturer's (Clontech) recommendations. The remaining coding and 5' non-coding sequences of Rack1 were isolated by RACE-PCR with HeLa Marathon-Ready cDNA (Clontech), subcloned into the TA cloning vector (Invitrogen) and confirmed by DNA sequencing. A full-length clone containing a C-terminal HA tag was then generated in the pCDNA3.1 vector (Invitrogen) by first amplifying the partial yeast clone with a 3' oligonucleotide encoding an HA-tag and an *Xba*I site and a 5' oligonucleotide complementary to the yeast plasmid pB42AD, followed by digestion of the product with *Sty*I and *Xba*I. Next, remaining Rack1 sequences in the TA clone were isolated by digestion with *Not*I and *Sty*I and finally the two Rack1-encoding pieces ligated into *Not*I and *Xba*I-digested pCDNA3.1. An inducible and myc-tagged expression clone for Rack1 was established by subcloning in the pINDHygro vector (Invitrogen). To generate alanine substitutions in the third and sixth WD domains of Rack1 we used appropriately designed oligonucleotides in a site-directed mutagenesis strategy (Quick Change Mutagenesis; Stratagene). All constructs were verified by sequencing before use.

### Cell culture, transfections and analysis of signaling properties

All CHO cells were maintained in DMEM medium plus 10% fetal calf serum (FCS) and 1% glutamine, nonessential amino acids and penicillin/streptomycin. Stable Rack1 transfectants were generated in wild-type or  $\alpha_{11b}\beta_3$ -expressing (A5) CHO cells (O'Toole et al., 1990) by cotransfection with HA-tagged Rack1 in pCDNA3.1 and pZeo (Invitrogen) using the lipofectamine reagent (Life Technologies). The medium was changed after 24 hours and after 48 hours the cells were grown in medium containing 250  $\mu$ g/ml zeocin (Invitrogen). After 2 weeks, colonies were picked, scaled up and analyzed for HA-Rack1

expression by western blotting with anti-Rack1 or anti-HA antibodies. The ligand-binding properties of these transfectants were determined by flow cytometric analysis of Pac1 binding (O'Toole et al., 1990).

Transient expression of Rack1 was achieved using a ponasterone inducible system (Invitrogen). Briefly, the appropriate cell types were cotransfected with the pHOOK vector (Invitrogen) to select for transfectants, pVgRxR and the pIND vector containing full-length Rack1. 24 hours after transfection the medium was changed to one containing 0.5% FCS and 5  $\mu$ M ponasterone (Invitrogen) and the cells were allowed to grow for another 20-24 hours. The transfectants were then isolated by magnetic sorting and induced Rack1 expression was determined by western blotting with an anti HA-antibody. Expression levels were determined by densitometry with an image analyzer (Alpha Imager 2000, Alpha Innotech Corporation).

To determine the effects of Rack1 overexpression on adhesion-stimulated signaling, we first incubated the appropriate cell types overnight in medium containing 0.5% FCS. The cells were then harvested with trypsin, washed in medium containing 0.5 mg/ml soybean trypsin inhibitor, resuspended in medium containing 0.2% BSA and incubated in suspension culture dishes for 2 hours at 37°C. At this time, some of the cells were collected and washed in phosphate-buffered saline (PBS), while the remainder were allowed to adhere to fibrinogen (fg)-coated dishes (15  $\mu$ g/ml) for various times. These adherent cells were then likewise collected and washed and all cells lysed on ice in a buffer consisting of 20 mM Tris-HCl, pH 7.4, 250 mM NaCl, 0.5% NP-40, 3 mM EGTA, 5 mM EDTA, 20 mM NaPi, 3 mM  $\beta$ -glycerophosphate, 1 mM  $\text{Na}_3\text{VO}_4$ , 1 mM PMSF, 10 mM NaF and 1 $\times$  complete protease inhibitor (Boehringer Mannheim). The lysates were clarified by centrifugation and protein concentration determined by BCA assay (Pierce). For immunoprecipitations, 300  $\mu$ g of lysate was incubated with the appropriate antibody overnight at 4°C and proteins recovered with protein G-sepharose. Isolated proteins were resolved by SDS-PAGE, transferred to nitrocellulose and detected after incubation with primary antibodies, horseradish-peroxidase (HRP)-conjugated secondary antibodies, and the ECL reagent (Amersham). For analysis of ERK1/2 activity levels, 60  $\mu$ g of crude lysate were directly used in western blotting analysis with phospho-ERK and ERK1/2-specific antibodies.

### Migration assays

Transwells were prepared by coating the bottom surface of the membrane with matrix proteins (50  $\mu$ g/ml in carbonate buffer (0.2 M  $\text{Na}_2\text{CO}_3/\text{NaHCO}_3$ , pH 9.3)) for a minimum of 1 hour, and then blocked with 5% milk in PBS plus 0.2% Tween 20. The cells to be examined were incubated in medium containing 0.5% serum overnight and then harvested and resuspended in serum-free medium at approximately  $10^6$ /ml. 0.5 ml of serum-free medium was applied to the bottom chamber while 100  $\mu$ l of the resuspended cells were then applied to the top of the Transwell, and migration was allowed to proceed for 8-16 hours. At this time medium in the bottom well was replaced with some of the same containing 5  $\mu$ M calcein AM and migration allowed to proceed for a final 30 minutes. The Transwells were then washed 2 $\times$  in PBS, the remaining cells on the top wiped off with a Q-Tip, and fluorescence read (excitation 485 nm, emission 530 nm) in a CytoFluor II. These values were normalized relative to the fluorescence of total cells initially seeded to the top of the Transwell and expressed as a percentage of control samples. The control samples were untransfected cells (in experiments where stable transfectants were used) or vector-transfected cells (in experiments where transient transfectants were used).

### Immunofluorescence

Glass coverslips were coated with 10  $\mu$ g/ml fg in carbonate buffer for 1 hour at room temperature and then blocked in 1% BSA.  $5 \times 10^4$  cells were then added and allowed to adhere for 2 hours at 37°C. At this time the cells were fixed with 1% paraformaldehyde, permeabilized

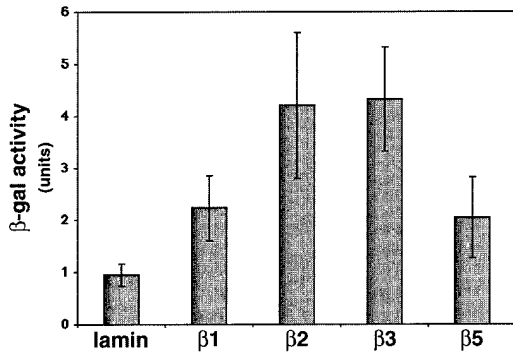

**Fig. 1.** Rack1 interacts with several integrin  $\beta$  subunit cytoplasmic domains. The interaction of full-length Rack1 with a non-specific clone (lamin) and with the cytoplasmic sequences of the  $\beta$ 1,  $\beta$ 2,  $\beta$ 3 and  $\beta$ 5 integrins was determined by yeast two-hybrid methodology and quantitated in a  $\beta$ -galactosidase assay (arbitrary units). In addition to previously reported interactions with  $\beta$ 1,  $\beta$ 2 and  $\beta$ 5, Rack1 also interacts with  $\beta$ 3.

with 0.1% Triton and incubated successively with a monoclonal anti-talin antibody, FITC-conjugated goat antimouse, rhodamine-phalloidin and Toto-3. The coverslips were then gently washed, mounted on glass slides and visualized using a fluorescence microscope.

## RESULTS

### Inside-out signaling is not affected by Rack1 overexpression

Rack1, a receptor for activated protein kinase C, has been implicated in binding to the integrin  $\beta$ 1,  $\beta$ 2 and  $\beta$ 5 cytoplasmic domains using the yeast two-hybrid approach (Liliental and Chang, 1998; Zhang and Hemler, 1999). Our two-hybrid studies confirm these results and also suggested an interaction with the  $\beta$ 3 cytoplasmic domain (Fig. 1). In addition, Rack1 has been implicated in binding to both protein kinase C and src

family members, two mediators of integrin bidirectional signaling (Chang et al., 1998; Ron et al., 1994). To begin to examine the role of Rack1 in integrin-mediated functions we stably overexpressed an HA-tagged form of this protein in CHO cells, which also express recombinant  $\alpha$ IIb $\beta$ 3 (A5 cells). After G418 selection and western blotting analysis of individual clones, we identified and maintained two clonal lines for further study. These two lines (R8 and R47) demonstrate both the slower migrating HA-tagged Rack1 (upper bands) as well as the endogenous Rack1 (lower bands) (Fig. 2A). Scanning the western blots suggested a 1.5- to twofold increase in Rack1 expression over levels in untransfected cells. Expression of HA-Rack1 in the A5 cells did not alter integrin expression levels (not shown) or gross morphological features. In all of the subsequent functional analyses described below, the behavior of the two clonal lines appeared identical.

As activators of protein kinase C have been widely used to stimulate integrin binding function, we first sought to determine whether Rack1 overexpression might affect integrin affinity state. Using the monoclonal antibody Pac1 as a ligand mimetic, however, we demonstrated that the clonal lines R8 and R47 remain in the same low-affinity state as their parental line, A5 (Fig. 2B). Ligand binding in these cells could only be stimulated with an activating antibody. Furthermore, Rack1 does not suppress ligand binding when overexpressed in cells with constitutively active, high-affinity integrins (data not shown). Thus Rack1 overexpression does not appear to affect inside-out signaling.

### Rack1 overexpression alters cytoskeletal structure, focal contact formation and cell migration

To begin to explore the effects of Rack1 on outside-in signaling, we first examined the cytoskeletal organization of the Rack1 overexpressing clones upon adhesion to fg. Immunofluorescence staining of wild-type CHO cells and the clonal line R8 with an anti-talin antibody and phalloidin demonstrated distinct differences between the two cell types. Specifically, the Rack1 overexpressers demonstrated a

**Fig. 2.** The overexpression of Rack1 does not affect integrin inside-out signaling. (A) To explore its effects on integrin binding affinity, we stably expressed Rack1 in a CHO line also expressing  $\alpha$ IIb $\beta$ 3 (A5 cells). Two clonal lines (R8 and R47) expressing both wild-type Rack1 (lower band) and the HA-tagged and transfected Rack1 (upper band) were identified and carried on for further study. (B) The binding of the ligand mimetic Pac1 to A5 cells and the two clonal lines was determined in a flow cytometry assay. Rack1 overexpression did not stimulate high levels of Pac1 binding (solid line) and this could only be accomplished after stimulation of the cell types with an activating antibody, LIBS 6 (shaded histogram). Excess RGD-containing peptide was used in these assays to block binding and demonstrate specificity (dotted line).

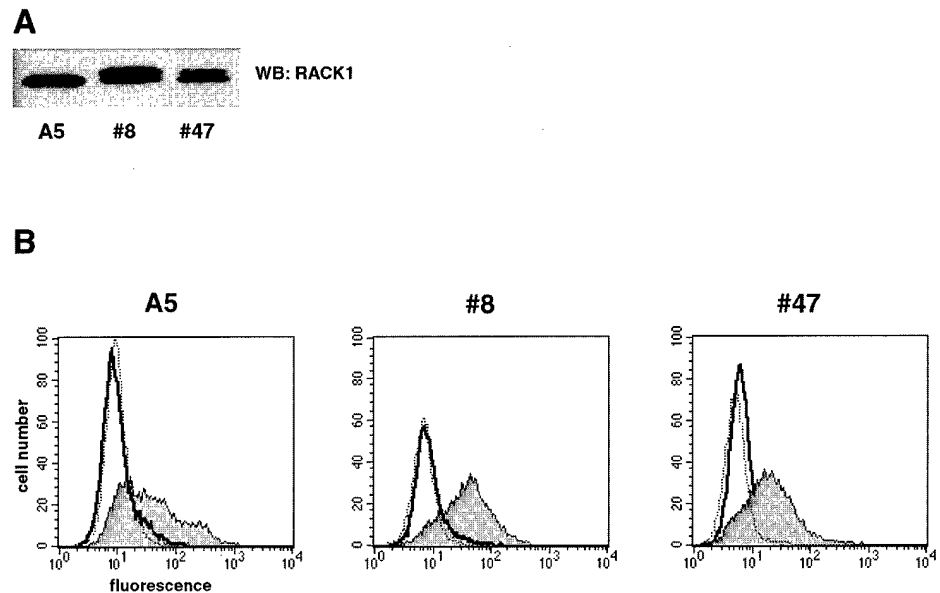

**Fig. 3.** Rack1 overexpression alters cytoskeletal organization. Parental CHO cells (left) and the Rack1 overexpressing clone R8 (right) were allowed to adhere to fg and then subjected to immunofluorescence staining as described in Materials and Methods. Analysis was with rhodamine-phalloidin (red) to visualize actin stress fibers and a talin antibody (green) to visualize focal contacts. Rack1 overexpressing cells demonstrate an increase in stress fibers and focal contacts compared to parental cells.

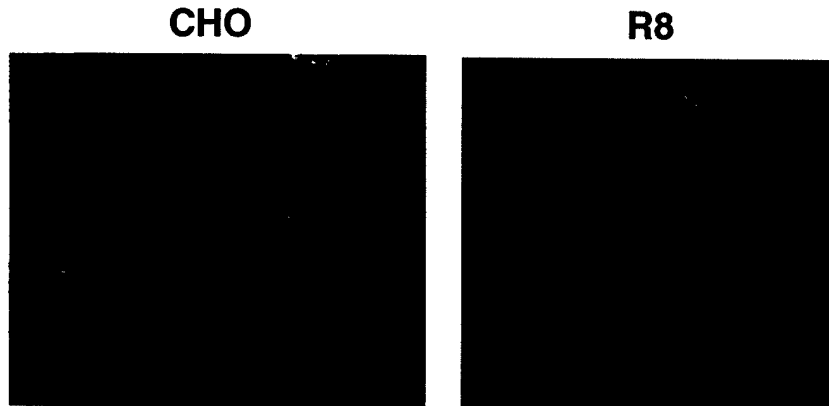

noticeable increase in both the number of stress fibers and focal contacts relative to wild-type cells (Fig. 3). Thus Rack1 overexpression affected the cytoskeletal organization of adherent cells.

The cytoskeletal organization of the adherent, Rack1-overexpressing cells was similar to the observed phenotype of FAK knockout cells (Ilic et al., 1995). Since these cells also demonstrate migration defects, we next sought to determine what effect Rack1 might have on integrin-mediated migration. Using a Transwell migration assay, we have consistently observed that the clonal line R8 demonstrated a 30-60% decrease in migration on fg-coated wells when compared to the parental cell line, A5 (Fig. 4A). As these studies were done with clonal lines, we also wished to see if transient overexpression of Rack1 would have a similar effect on migration. To do this, we subcloned HA-tagged Rack1 into the pINDHYGRO vector (Invitrogen) and induced its expression with the ecdysone analog, ponasterone (Fig. 4A). These transient transfectants reproducibly demonstrated an approximately twofold increase in Rack1 expression. Similar to those results with the stable lines, transient overexpression of Rack1 in A5 cells also deterred migration on fg (Fig. 4A). Next, we wished to determine if these Rack1 effects were specific to these CHO,  $\alpha_{IIb}\beta_3$ -expressing cells. We therefore stably overexpressed Rack1 in wild-type CHO cells (clonal line CR22) and examined their migratory behavior on fn, which was mediated by endogenous  $\alpha_5\beta_1$  (Fig. 4B). As with

the A5 cells, overexpression of Rack1 in CHO cells inhibited cell migration. Finally, we observed similar effects on migration when we performed these CHO cells studies in a transient manner (Fig. 4B). Thus migration mediated by different integrins was inhibited.

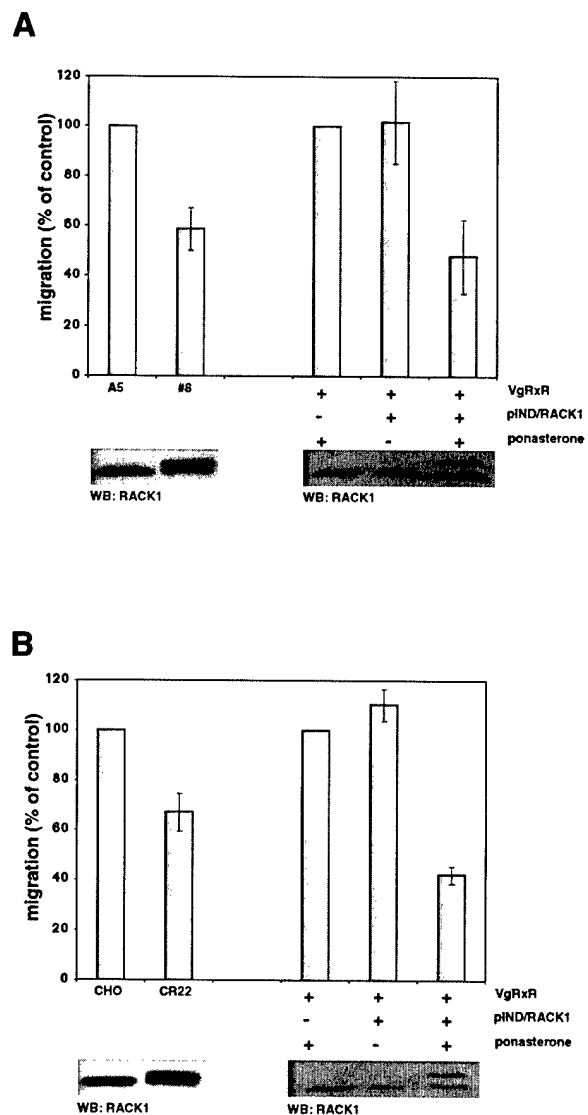

**Fig. 4.** Rack1 overexpression inhibits cell migration. (A) A5 cells and the clonal line R8 were allowed to migrate on fg-coated Transwells and the number of migrated cells quantitated by calcein AM staining as described in Materials and Methods (left bars). The stable Rack1 overexpressing line demonstrated an approximate 60% decrease in cell migration relative to the parental line. A5 cells were also transiently transfected with pHOOK and variably with pVgRxR and pINDRack1 as indicated (right bars). Protein expression was induced after 24 hours with 5  $\mu$ M ponasterone and transfectants isolated after 48 hours by magnetic sorting. Expression of Rack1 was determined by western blotting with an anti-Rack1 antibody (bottom) while migratory properties were analyzed as above in a Transwell assay. (B) Stable expression of Rack1 was also accomplished in wild-type CHO cells. Migration of the parental cells and a Rack1 overexpressing clone (CR22) on fn-coated Transwells were examined as above (left bars). Finally, transient Rack1 expression and migration was accomplished in CHO cells as described above (right bars and bottom). In all cases overexpression of Rack1 inhibited cell migration relative to parental cells.

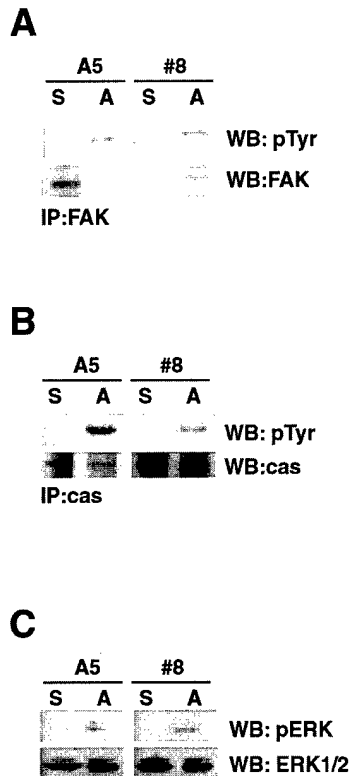

**Fig. 5.** Rack1 does not affect downstream signaling from src. Parental cells (A5) or the Rack1 overexpressers (R8) were serum starved overnight and then kept in suspension for 2 hours. At this time some of the cells were harvested and lysed (S) while the remainder were allowed to adhere to fg-coated dishes (A) for 10 minutes and then harvested and lysed. (A) Equal amounts of lysate were then immunoprecipitated with an anti-FAK antibody and isolated proteins resolved by SDS-PAGE and subjected to western blotting with anti-phosphotyrosine and anti-FAK antibodies, as indicated. Lysates prepared as described above were also immunoprecipitated with an anti-cas antibody and analyzed by western blotting with anti-phosphotyrosine and anti-cas antibodies (B). Finally 60  $\mu$ g of lysate from suspension and adherent cells were resolved and analyzed by western blotting with a phospho-ERK specific antibody (C). The same blot was stripped and then re probed with antibodies to ERK1 and ERK2. There appeared to be no deficiencies in FAK phosphorylation, cas phosphorylation, and ERK1/2 activation when we compared parental and Rack1 overexpressing cells.

### Rack1 overexpression does not inhibit downstream signaling from src

As noted above, it has been reported that Rack1 can bind to and inactivate src family kinases. To explore whether this might account for the observed phenotype in the Rack1 overexpressing lines, we determined the effects on some of the downstream targets of src signaling. Two substrates of src, FAK and p130cas, have been implicated in migratory function (Cary et al., 1996; Gilmore and Romer, 1996; Klemke et al., 1998) and we initially examined if these substrates were differentially phosphorylated in our Rack1 overexpressing cell lines. To do this A5 and R8 cells were serum starved overnight, put into suspension for 2 hours, and then allowed to adhere to fg for 10 minutes. Lysates from these samples were then

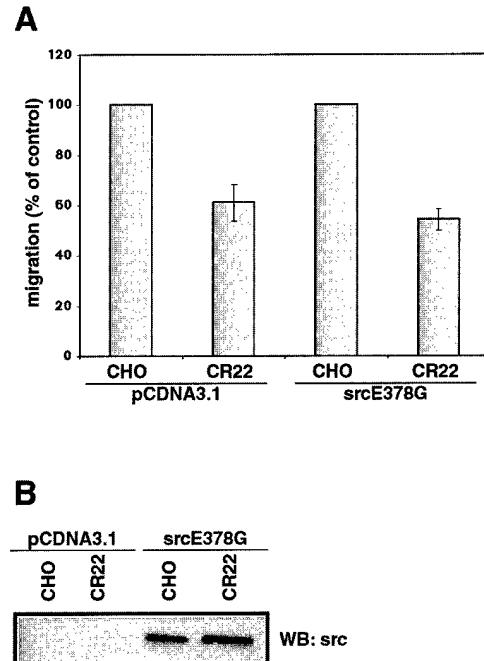

**Fig. 6.** Activated src does not reverse Rack1-mediated suppression of migration. (A) Wild-type CHO cells and those overexpressing Rack1 (CR22) were transfected with the pCDNA3.1 vector or a constitutively active src construct as indicated and transfectants isolated by magnetic sorting. The cells were then allowed to migrate on fn-coated Transwells and analyzed by calcein AM staining as above. (B) Expression of the transfected src construct was determined by western blotting as indicated.

immunoprecipitated with anti-FAK and anti-cas antibodies and isolated proteins analyzed by western blotting. Both the Rack1 overexpressing line and wild-type cells demonstrated increases in FAK and cas phosphorylation upon adhesion (Fig. 5A,B). Src activity has also been implicated in the upregulation of the MAP kinases. Therefore, we examined whether ERK1/2 were differentially phosphorylated and activated in Rack1 overexpressing cells. However western blotting with a phospho-ERK specific antibody suggested comparable upregulation of these kinases upon adhesion (Fig. 5C). Thus signaling events downstream of src do not appear to be disrupted in the Rack1 overexpressing cells.

As a final approach to determine if altered src function could account for the decreased motility of Rack1 overexpressing cells, we asked whether we could reverse this phenotype by transfection with an activated src construct. However, transfection of CR22 cells with srcE378G did not enhance migration to wild-type levels (Fig. 6A), despite ample expression of this src variant (Fig. 6B). Thus it appears that Rack1 overexpression did not diminish src activity in our system and this is not a mechanism for the observed migratory defects.

### Inhibition of cell migration is reversed by a mutant Rack1 construct

Two sequence motifs in Rack1, one in its third WD domain and one in its sixth WD domain, are homologous to areas in other PKC-binding proteins (Ron et al., 1994). Furthermore,

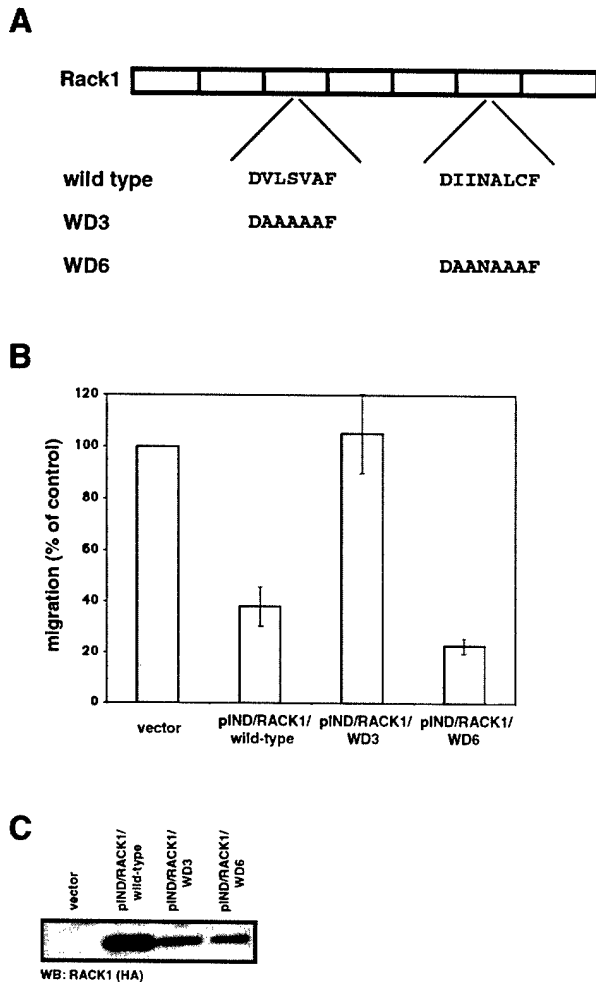

**Fig. 7.** Mutation of a putative PKC-binding region in Rack1 reverses its effects on cell migration. (A) The WD domain structure of wild-type Rack1 is illustrated. Putative PKC binding sites exist in the third and sixth domains and residues in these areas have been targeted by alanine substitution as indicated. Distinct constructs containing WD3 substitutions and WD6 substitutions have been generated. (B) CHO cells were transiently transfected with vector, wild-type Rack1, the WD3 variant, or the WD6 variant and isolated by magnetically sorting after 48 hours. Equal amounts were applied to fn-coated Transwells and allowed to migrate for 12 hours. Quantitation of migrated cells was by calcein staining as described above. While cells expressing wild-type Rack1 and the WD6 variant demonstrated reduced migration, vector transfectants and those expressing the WD3 variant had wild-type motility. (C) Western blotting analysis demonstrated that all constructs expressed equally well.

synthetic peptides corresponding to each of these sequences have been directly implicated in PKC binding and in downstream, PKC-dependent functional effects (Ron et al., 1994; Ron and Mochly-Rosen, 1994). Therefore, to assess the role of Rack1-PKC interactions in our observed inhibition of migration, we have generated alanine substitutions within these areas (Fig. 7A). When we overexpressed a Rack1 construct with alterations in its WD6 domain, we observed no change from those effects with wild-type Rack1 (Fig. 7B). That is migration was inhibited with respect to control transfectants. However, when we overexpressed a variant with substitutions

in its WD3 domain, we observed no inhibition of migration (Fig. 7B). All Rack1 variants were expressed to similar extents. Thus PKC interactions with a motif in the third WD domain of Rack1 appear to be important in integrin outside-in signaling, especially with regard to cell migration.

## DISCUSSION

Racks have been classically defined as saturable, specific receptors that stabilize PKC isoforms in the active state and anchor them to membranes or other functional sites (Mochly-Rosen and Gordon, 1998). The data presented in this paper suggest that Rack1, a receptor for the PKC  $\beta$  isoform that also associates with integrins and src kinases as well (Chang et al., 1998; Liliental and Chang, 1998) is involved in regulating cytoskeletal organization and downstream events such as integrin-mediated cell migration. Rack1 thus represents another player in a cell's migratory machinery and a novel therapeutic target for regulating this process.

Unlike other proteins which interact with specific integrins (eg.  $\beta_3$ -endoneixin, Shattil et al., 1995; CIB, Naik et al., 1997), we and others have shown that Rack1 appears to interact with several integrin  $\beta$  subunit tails. The functional studies described here examine Rack1 effects on downstream signaling mediated by the  $\beta_1$  and  $\beta_3$  integrins. We do not yet know if Rack1 overexpression also affects migration mediated by other integrins ( $\beta_2$  and  $\beta_5$ ). Thus it is not clear if Rack1 broadly affects integrin outside-in signaling or if some measure of specificity, which includes the  $\beta_1$  and  $\beta_3$  integrins, does exist. It is also of interest that we could not overexpress Rack1 to greater than twofold above endogenous levels in either the stable or transient systems. One potential explanation for this is that, like structurally homologous G-protein  $\beta$  subunits, Rack1 may exist as part of a greater protein complex. These additional components may be limiting and therefore affecting Rack1 expression levels.

The multiple binding partners of Rack1 suggest several possibilities whereby this protein might affect cytoskeletal structure and cell motility. First, this protein has been reported to bind to and inactivate src family kinases. Src in turn can be linked to migratory behavior via distinct pathways involving the phosphorylation of FAK and p130cas. Phosphorylation of FAK at residue 925 creates a binding site for the grb2-sos complex and induction of ERK kinase activity through the classical ras pathway. The migration of FG carcinoma cells has been shown to be dependent upon ERK activity and the subsequent phosphorylation of myosin light chain kinase and myosin light chains (Klemke et al., 1997). On the other hand, phosphorylation of p130cas creates a binding site for crk and this association has been demonstrated to be important in the migratory and invasive properties of carcinoma cells in a manner dependent upon the G protein, rac (Klemke et al., 1998). Thus Rack1 inhibition of src kinases seems an attractive hypothesis for the migratory defects we have observed. However, our Rack1 overexpressing cell lines did not demonstrate deficiencies in FAK or cas phosphorylation and MAP kinase activity (Fig. 5), and we do not believe this is a mechanism for reduced migration of our cell lines. In support of this, transfection with a constitutively active src construct did not overcome the migratory defect in Rack1 overexpressing

cells. In this regard, our results appear to differ from those of Chang et al., where reduced src activity upon Rack1 overexpression could explain their observed phenotypes such as altered growth rates of NIH 3T3 cells (Chang et al., 1998). Cell type differences might be an explanation for these discrepancies. Nevertheless we have not measured src activity directly in our cell lines and cannot discount the possibility that Rack1-mediated inhibition of src activity may limit migration by another means. In this regard, it has been demonstrated that focal adhesion turnover is reduced in cells expressing kinase inactive or myristylation-defective src constructs (Fincham and Frame, 1998). Cells with decreased focal contact turnover would be predicted to have increased adhesive strength, and consequently, decreased motility. Consistent with this, we have observed striking differences in the number of stress fibers and focal contacts between wild-type and Rack1 overexpressing cells (Fig. 3).

On the other hand, Rack1 interaction with PKC isoforms may be important in our observed phenotypes. The involvement of PKCs in several integrin-mediated functions such as spreading (Haller et al., 1998; Vuori and Ruoslahti, 1993), cytoskeletal assembly and adhesion (Haller et al., 1998; Lewis et al., 1996), migration (Derman et al., 1997; Rigot et al., 1998; Volkov et al., 1998), receptor endocytosis (Panetti et al., 1995), and FAK and MAP kinase activation (Lewis et al., 1996; Miranti et al., 1999; Rigot et al., 1998) has been well documented. Interestingly, it has been reported that a specific isoform, PKC $\zeta$ , is involved in the adhesion and chemotaxis of neutrophils (Laudanna et al., 1998). Thus, the association of Rack1 with integrin tails might enable or otherwise affect PKC isoform-specific localization. Overexpression of Rack1 might disrupt this balance, thereby contributing to the observed cytoskeletal and migratory effects. Although we have not directly analyzed its PKC binding properties, the absence of a migratory deficit in cells overexpressing the WD3 domain variant appears to support this idea. It will be interesting to identify specific residues within this targeted area that mediate these effects. It is presently not clear why cells expressing the WD6 variant did not also have this property. Peptides corresponding to this motif have also been implicated in PKC binding and the downstream functional consequences thereof (Ron et al., 1994; Ron and Mochly-Rosen, 1994). Finally, as Rack1 is composed of WD domains and these motifs have been implicated in protein-protein interactions, it is also conceivable that another unrecognized molecule may mediate our observed effects. In this scenario, Rack1 overexpression and the WD3 domain mutations might affect things such as PKC activity, substrate availability, or protein folding.

In addition to Rack1, two other Racks have been cloned and identified. These include  $\beta'$ -COP, an  $\epsilon$ PKC receptor (Csukai et al., 1997), and Pick1, an  $\alpha$ PKC receptor (Staudinger et al., 1995). While little is known about the structure of Pick1, Rack1 and  $\beta'$ -COP consist of WD repeats, a structural motif held in common with G protein  $\beta$  subunits. Each WD repeat consists of approximately 40 residues with a common core typically bracketed by GH (glycine, histidine) and WD (tryptophan, aspartic acid) (Neer et al., 1994). Structure determinations of WD-containing proteins suggest a propeller motif where each propeller blade consists of four antiparallel  $\beta$  sheets (Garcia-Higuera et al., 1998). WD repeat proteins are involved in diverse cellular functions including cytoskeletal

assembly, intracellular trafficking, mRNA splicing, transcriptional regulation and, as implicated in our studies, cell migration. It is not known if the other identified Racks,  $\beta'$ -COP and Pick1, can associate with integrins or are involved in integrin-mediated function. On the contrary,  $\beta'$ -COP has been implicated in vesicular trafficking and Golgi function (Csukai et al., 1997). Nevertheless, it is tempting to speculate that these or other Racks might function to translocate PKCs to integrins or focal contacts and assist in downstream signaling. In light of this idea, it is interesting to note that another WD-containing protein, WAIT-1, has been isolated in a yeast two-hybrid screen using the integrin  $\beta_7$  tail as a bait (Rietzler et al., 1998). It is presently unknown whether WAIT-1 functions as a Rack or what the functional consequences of WAIT-1-integrin  $\beta_7$  interactions might be.

In summary, we have shown that overexpression of the scaffolding protein Rack1 in CHO cells increases the number of actin stress fibers and focal contacts upon adhesion and decreases cell motility in a manner that likely involves its interaction with PKC. Identification of those signaling pathways involving Rack1 and PKC or disrupting their association with integrins might define a novel means of regulating migration in pathological situations.

This work was supported in part by HL53620 from the National Institutes of Health.

## REFERENCES

- Battaini, F., Pascale, A., Paoletti, R. and Govoni, S. (1997). The role of anchoring protein Rack1 in PKC activation in the aging rat brain. *Trends Neurosci.* **20**, 410-415.
- Cary, L. A., Chang, J. F. and Guan, J. (1996). Stimulation of cell migration by overexpression of focal adhesion kinase and its association with src and fyn. *J. Cell Sci.* **109**, 1787-1794.
- Chang, B. Y., Conroy, K. B., Machleder, E. M. and Cartwright, C. A. (1998). Rack1, a receptor for activated C kinase and a homolog of the  $\beta$  subunit of G proteins, inhibits activity of src tyrosine kinases and growth of NIH3T3 cells. *Mol. Cell Biol.* **18**, 3245-3256.
- Chen, P., Xie, H., Sekar, M., Gupta, K. and Wells, A. (1994). Epidermal growth factor receptor-mediated cell motility: phospholipase C activity is required but mitogen-activated protein kinase is not sufficient for induced cell movement. *J. Cell Biol.* **127**, 847-857.
- Csukai, M., Chen, C.-H., DeMatteis, M. A. and Mochly-Rosen, D. (1997). The coatomer protein  $\beta'$ -COP, a selective binding protein (Rack) for protein kinase C. *J. Biol. Chem.* **272**, 29200-29206.
- Derman, M. P., Toker, A. J., Hartwig, H., Spokes, K., Falck, J. R., Chen, C. S., Cantley, L. C. and Cantley, L. G. (1997). The lipid products of phosphoinositide 3-kinase increase cell motility through protein kinase C. *J. Biol. Chem.* **272**, 6465-6470.
- Fincham, V. J. and Frame, M. C. (1998). The catalytic activity of Src is dispensable for translocation to focal adhesions but controls the turnover of these structures during cell motility. *EMBO J.* **17**, 81-92.
- Garcia-Higuera, I., Gaitatzes, C., Smith, T. F. and Neer, E. J. (1998). Folding a WD repeat propeller. *J. Biol. Chem.* **273**, 9041-9049.
- Geijsen, N., Spaargaren, M., Raaijmakers, J. A. M., Lammers, J.-W. J., Koenderman, L. and Coffey, P. J. (1999). Association of Rack1 and PKC $\beta$  with the common  $\beta$ -chain of the IL-5/IL-3/GM-CSF receptor. *Oncogene* **18**, 5126-5130.
- Gilmore, A. P. and Romer, L. H. (1996). Inhibition of focal adhesion kinase (FAK) signaling in focal adhesions decreases cell motility and proliferation. *Mol. Biol. Cell.* **7**, 1209-1224.
- Haller, H., Lindschau, C., Maasch, C., Olthoff, H., Kurscheid, D. and Luft, F. C. (1998). Integrin-induced protein kinase C $\alpha$  and C $\epsilon$  translocation to focal adhesions mediates vascular smooth muscle cell spreading. *Circ. Res.* **82**, 157-165.
- Huttenlocher, A., Ginsberg, M. H. and Horwitz, A. F. (1996). Modulation

- of cell migration by integrin-mediated cytoskeletal linkages and ligand-binding affinity. *J. Cell Biol.* **134**, 1551-1562.
- Huttenlocher, A., Palecek, S. P., Lu, Q., Zhang, W., Mellgren, R. L., Lauffenburger, D. A., Ginsberg, M. H. and Horwitz, A. F.** (1997). Regulation of cell migration by the calcium-dependent protease calpain. *J. Biol. Chem.* **272**, 32719-32722.
- Ilic, D., Furuat, Y., Kanazawa, S., Takeda, N., Sobue, K., Nakatsuji, N., Nomura, J., Fujimoto, J., Okada, M., Yamamoto, T. and Aizawa, S.** (1995). Reduced cell motility and enhanced focal adhesion contact formation in cells from FAK-deficient mice. *Nature* **377**, 539-544.
- Klemke, R. L., Cai, S., Giannini, A. L., Gallagher, P. J., deLanerolle, P. and Cheresch, D. A.** (1997). Regulation of cell motility by mitogen-activated protein kinase. *J. Cell Biol.* **137**, 481-492.
- Klemke, R. L., Leng, J., Molander, R., Brooks, P. C., Vuori, K. and Cheresch, D. A.** (1998). Cas/crk coupling serves as a 'molecular switch' for induction of cell migration. *J. Cell Biol.* **140**, 961-972.
- Laudanna, C., Mochly-Rosen, D., Liron, T., Constantin, G. and Butcher, E. C.** (1998). Evidence of  $\zeta$  protein kinase C involvement in polymorphonuclear neutrophil integrin-dependent adhesion and chemotaxis. *J. Biol. Chem.* **273**, 30306-30315.
- Lewis, J. M., Cheresch, D. A. and Schwartz, M. A.** (1996). Protein kinase C regulates  $\alpha_v\beta_5$ -dependent cytoskeletal associations and focal adhesion kinase phosphorylation. *J. Cell Biol.* **134**, 1323-1332.
- Liliental, J. and Chang, D. D.** (1998). Rack1, a receptor for activated protein kinase C, interacts with integrin  $\beta$  subunit. *J. Biol. Chem.* **273**, 2379-2383.
- Miranti, C. K., Ohno, S. and Brugge, J. S.** (1999). Protein kinase C regulates integrin-induced activation of the extracellular regulated kinase pathway upstream of shc. *J. Biol. Chem.* **274**, 10571-10581.
- Mochly-Rosen, D. and Gordon, A. S.** (1998). Anchoring proteins for protein kinase C: a means for isozyme selectivity. *FASEB J.* **12**, 35-42.
- Naik, U. P., Patel, P. M. and Parise, L. V.** (1997). Identification of a novel calcium-binding protein that interacts with the integrin  $\alpha_{IIb}$  cytoplasmic domain. *J. Biol. Chem.* **272**, 4651-4656.
- Neer, E. J., Schmidt, C. J., Nambudripad, R. and Smith, T. F.** (1994). The ancient regulatory-protein family of WD-repeat proteins. *Nature* **371**, 297-300.
- Ng, T., Shima, D., Squire, A., Bastiaens, P. I. H., Gschmeissner, S., Humphries, M. J. and Parker, P. J.** (1999). PKC $\alpha$  regulates  $\beta_1$  integrin-dependent cell motility through association and control of integrin traffic. *EMBO J.* **14**, 3909-3923.
- Nguyen, D. H. D., Catling, A. D., Webb, D. J., Sankovic, M., Walker, L. A., Somlyo A. V., Weber, M. J. and Gonias, S. L.** (1999). Myosin light chain kinase functions downstream of ras/ERK to promote migration of urokinase-type plasminogen activator-stimulated cells in an integrin-selective manner. *J. Cell Biol.* **146**, 149-164.
- Nobes, C. D. and Hall, A.** (1995). Rho, rac and cdc42 GTPases regulate the assembly of multi-molecular focal complexes associated with actin stress fibers, lamellipodia and filopodia. *Cell* **81**, 53-62.
- Nobes, C. D. and Hall, A.** (1999). Rho GTPases control polarity, protrusion, and adhesion during cell movement. *J. Cell Biol.* **144**, 1235-1244.
- O'Toole, T. E., Loftus, J. C., Du, X., Glass, A. A., Ruggeri, Z. M., Shattil, S. J., Plow, E. F. and Ginsberg, M. H.** (1990). Affinity modulation of the  $\alpha_{IIb}\beta_3$  integrin (platelet GPIIb-IIIa) is an intrinsic property of the receptor. *Cell Regulation* **1**, 883-893.
- Panetti, T.S., Wilcox, S. A., Horzempa, C. and McKeown-Longo, P. J.** (1995).  $\alpha_v\beta_5$  integrin receptor-mediated endocytosis of vitronectin is protein kinase C-dependent. *J. Biol. Chem.* **270**, 18593-18597.
- Rietzler, M., Bittner, M., Kolanus, W., Schuster, A. and Holzmann, B.** (1998). The human WD repeat protein WAIT-1 specifically interacts with the cytoplasmic tails of  $\beta_7$ -integrins. *J. Biol. Chem.* **273**, 27459-27466.
- Rigot, V., Lehmann, M., Andre, F., Daemi, N., Marvaldi, J. and Luis, J.** (1998). Integrin ligation and PKC activation are required for migration of colon carcinoma cells. *J. Cell Sci.* **111**, 3119-3127.
- Rodriguez, M. M., Ron, D., Touhara, K., Chen, C.-H. and Mochly-Rosen, D.** (1999). Rack1, a protein kinase C anchoring protein, coordinates the binding of activated protein kinase C and select pleckstrin homology domains in vitro. *Biochemistry* **38**, 13787-13794.
- Rodriguez-Vicana, P., Warne, P. H., Khwaja, A., Marte, B. M., Pappin, D., Das, P., Waterfield, M. D., Ridley, A. and Downward, J.** (1997). Role of phosphoinositide-3-OH kinase in cell transformation and control of the actin cytoskeleton by ras. *Cell* **89**, 457-467.
- Ron, D., Chen, C.-H., Caldwell, J., Jamieson, L., Orr, E. and Mochly-Rosen, D.** (1994). Cloning of an intracellular receptor for protein kinase C: a homolog of the  $\beta$  subunit of G proteins. *Proc. Natl. Acad. Sci. USA* **91**, 839-843.
- Ron, D. and Mochly-Rosen, D.** (1994). Agonists and antagonists of protein kinase C function, derived from its binding proteins. *J. Biol. Chem.* **269**, 21395-21398.
- Ron, D., Luo, J. and Mochly-Rosen, D.** (1995). C2 region-derived peptides inhibit translocation and function of  $\beta$  protein kinase C in vivo. *J. Biol. Chem.* **270**, 24180-24187.
- Shattil, S. J., O'Toole T. E., Eigenthaler, M., Thon, V., Williams, M., Babiorek, B. M. and Ginsberg, M. H.** (1995).  $\beta_3$ -endoneixin, a novel polypeptide that interacts specifically with the cytoplasmic tail of the integrin  $\beta_3$  subunit. *J. Cell Biol.* **131**, 807-816.
- Staudinger, J., Zhou, J., Burgess, R., Elledge, S. J. and Olson, E. N.** (1995). Pick1: a perinuclear binding protein and substrate for protein kinase C isolated by the yeast two-hybrid system. *J. Cell Biol.* **128**, 263-271.
- Takaishi, K., Kiluchi, A., Kuroda, S., Kotani, K., Sasaki, T. and Takai, Y.** (1993). Involvement of rho p21 and its inhibitory GDP/GTP exchange protein (rho GDI) in cell motility. *Mol. Cell. Biol.* **13**, 72-79.
- Volkov, Y., Long, A. and Kelleher, D.** (1998). Inside the crawling T cell: leukocyte function-associated antigen-1 cross-linking is associated with microtubule-directed translocation of protein kinase C isoenzymes  $\beta(1)$  and  $\delta$ . *J. Immunol.* **161**, 6487-6495.
- Vuori, K. and Ruoslahti, E.** (1993). Activation of protein kinase C precedes  $\alpha_5\beta_1$  integrin-mediated cell spreading on fibronectin. *J. Biol. Chem.* **268**, 21459-21462.
- Yarwood, S. J., Steele, M. R., Scotland, G., Houslay, M. D. and Bolger, G. B.** (1999). The Rack1 signaling scaffold protein selectively interacts with cAMP-specific phosphodiesterase PDE4D5 isoform. *J. Biol. Chem.* **274**, 14909-14917.
- Zhang, X. A. and Hemler, M. E.** (1999). Interaction of the integrin  $\beta_1$  cytoplasmic domain with ICAP-1 protein. *J. Biol. Chem.* **274**, 11-19.
- Zhang, Z.-H., Johnson, J. A., El-Sherif, N., Mochly-Rosen, D. and Boutjdir, M.** (1997). C2-region derived peptides of  $\beta$ -protein kinase C regulate cardiac calcium channel. *Circ. Res.* **80**, 720-729.

Report

## Migration of breast epithelial cells on Laminin-5: differential role of integrins in normal and transformed cell types

George E. Plopper,\* Susan Z. Domanico, Vincenzo Cirulli,<sup>1</sup> William B. Kiosses, and Vito Quaranta  
*Department of Cell Biology/SBR12, The Scripps Research Institute, La Jolla, CA, USA;*<sup>1</sup>*The Whittier Institute, Department of Pediatrics, University of California San Diego, La Jolla, CA, USA; \*current address: Department of Biological Sciences, University of Nevada, Las Vegas, NV, USA*

**Key words:** breast neoplasms, extracellular matrix, haptotaxis, integrins, laminins

### Summary

We examined the role of Laminin-5 (Ln-5) an extracellular matrix component of breast gland basement membrane, in supporting migration of normal (HUMEC), immortalized (MCF-10A), and malignant breast epithelial cells that exhibit different degrees of metastatic potential (MDA-MB-435>MDA-MB-231>MCF-7). HUMEC, MCF-10A, and MCF-7 cells all adhered to purified Ln-5 through the  $\alpha3\beta1$  integrin receptor in adhesion assays. However, HUMEC and MCF-10A cells remained statically adherent, while MCF-7 cells migrated on Ln-5 in Transwell and colloidal gold displacement assays. Anti- $\alpha3$  integrin antibodies blocked migration of MCF-7 cells on Ln-5. MDA-MB-231 and MDA-MB-435 cells bound and migrated on Ln-5 through a  $\beta1$  integrin receptor that is insensitive to antibodies that block the function of  $\alpha1$ ,  $\alpha2$ ,  $\alpha3$ ,  $\alpha4$ ,  $\alpha5$ ,  $\alpha6$ , and  $\alphaV$  integrin subunits. Migration of all cell types tested was blocked by CM6, a monoclonal antibody directed to a cell adhesion site on the  $\alpha3$  chain of Ln-5. Thus, Ln-5 may play an important role in regulating adhesion and migration in normal and transformed breast epithelium. Our results indicate that the type of integrin utilized by breast cells to interact with Ln-5, as well as its functional state, may determine whether cells will be statically adherent or migratory on Ln-5.

### Introduction

Extracellular matrix (ECM) proteins play a critical role in regulating cell growth, migration, and differentiation. Cells bind ECM molecules through specific receptors, most of which belong to the integrin family of cell surface adhesion molecules. Integrins are heterodimers, consisting of one  $\alpha$  and one  $\beta$  subunit. At present, at least 16  $\alpha$  and 8  $\beta$  integrin subunits have been identified, which organize into at least 20 different receptors that bind a wide variety of ECM and cell surface molecules [1]. Many of

these receptors cluster and associate with cytoplasmic molecules to form a specialized cell adhesion site, the focal adhesion complex, that links the ECM with the cytoskeleton [2]. Integrins also serve as signal transducing elements that activate chemical signalling pathways responsible for controlling cell growth, motility, and differentiation [3]. During malignant transformation, focal adhesions and actin stress fibers become disrupted, adhesion to ECM is deregulated, and cells become highly migratory [3]. To migrate, cells must integrate multiple incoming signals. Once committed to migration,

they coordinately regulate, both spatially and temporally, surface receptors and cytoskeleton, in order to generate traction and movement [4]. To accomplish forward movement, there must be a balance between the establishment of plasma membrane-ECM adherence contacts at the cell leading edge, and their coordinated, asymmetric release at the cell trailing edge [5]. Integrins play an important role in migration because they can generate traction by forming mechanical transmembrane links between ECM and cytoskeleton [4].

How specific ECM molecules and their integrin receptors contribute to malignant transformation *in vivo* remains largely unknown. Previous studies have suggested that changes in expression of ECM molecules *in situ* may contribute to malignancy in breast, although the functional significance of these changes is not yet known [e.g., (6–13)]. Likewise,  $\alpha 2$ ,  $\alpha 3$ , and  $\alpha 6$  integrins may play a role during breast tumorigenesis, but the correlation between expression of these integrins and tumor progression is not well established [e.g., (14–27)].

In this study we examined the adhesion and migration of normal and spontaneously immortalized breast epithelial cells (HUMEC, MCF-10A) and cells that exhibit different degrees of malignancy (MDA-MB-435>MDA-MB-231>MCF-7), on one member of the laminin family of ECM proteins, Ln-5. We found that while HUMEC, MCF-10A, and low malignancy MCF-7 cells preferentially adhered to Ln-5 through the  $\alpha 3\beta 1$  integrin receptor in rapid adhesion assays, only MCF-7 cells migrated on Ln-5 in Transwell and colloidal gold displacement assays. The more malignant cell lines MDA-MB-435 and MDA-MB-231 adhered and migrated on Ln-5 using an unidentified  $\beta 1$ -containing integrin receptor. Together these findings suggest that  $\alpha 3\beta 1$  integrin-mediated adhesion to Ln-5 may play a role in both maintenance of the normal phenotype and in early stages of malignant progression in breast.

## Materials and methods

### Cells

HUMECs (ninth passage) were purchased from Clonetics (San Diego, CA), maintained in Mammary Epithelial Growth Medium (Clonetics), a serum-free defined medium, and used by passage 12. Cells were passaged using the Clonetics Reagent Pack as indicated by the manufacturer. MCF-10A cells [28] were obtained from the American Tissue Culture Collection (ATCC) and were maintained and passaged in DFCI medium according to Band and Sager [29]. MCF-7 [30], MDA-MB-231 [31], and MDA-MB-435 [32] cells were obtained from ATCC, maintained in RPMI supplemented with 10% fetal calf serum (Gemini, Irvine, CA) and 2 mM glutamine/penicillin G (100 units/ml)/Streptomycin sulfate (100  $\mu$ g/ml) (BioWhittaker, Walkersville MD), and routinely passaged using trypsin/EDTA (BioWhittaker). Rat bladder carcinoma 804G cells [33] were obtained from Jonathan Jones, Northwestern University, and were passaged and maintained under conditions identical to those for MCF-7 cells except that DMEM was substituted for RPMI medium. All cells were maintained at 37°C in a humidified incubator containing 10% CO<sub>2</sub>. 804G cell conditioned medium was collected after 3 days of culturing and was clarified by centrifugation at 1500  $\times$  g.

### Antibodies

Rat monoclonal antibody GoH3 against the  $\alpha 6$  integrin was purchased from Immunotech (Westbrook, ME). Mouse monoclonal antibodies against integrin  $\alpha 2$  (clone P1E6),  $\alpha 3$  (clone P1B5),  $\alpha 5$  (clone P1D6), and  $\beta 1$  (clone P4C10) were purchased from Gibco (Gaithersburg, MD). Mouse monoclonal antibodies against integrin  $\alpha 1$  (clone 5E8D9) and  $\alpha 4$  (clone A4-PUJ1) were purchased from Upstate Biotechnology Inc. (Lake Placid, NY). Rat monoclonal antibody 69-6-5 against integrin  $\alpha V$  was a kind gift from J. Marvaldi [34]. Mouse antibody MOPC 31c and goat anti-mouse and anti-rat secondary antibodies coupled to fluorescein isoth-

iocyanate were purchased from Sigma (St. Louis, MO). Mouse monoclonal antibodies TR1, FM3, and CM6 against Ln-5 were isolated and purified from ascites fluid as described elsewhere [35].

#### *Confocal immunofluorescent detection of Ln-5 in rat mammary gland*

Immunofluorescent labeling for Ln-5 was performed on 8  $\mu$ m thick cryostat sections prepared from snap frozen adult rat mammary gland. Sections were mounted on glass slides, dried at room temperature (RT) for 1 hour, fixed in freshly made 4% formaldehyde (from paraformaldehyde) for 20 minutes at 4° C, permeabilized in 0.1% saponin for 5 minutes at room temperature, and then incubated in 50 mM glycine in PBS to saturate reactive groups generated by formaldehyde fixation. Nonspecific binding was blocked by incubation of sections in PBS containing 2% donkey normal serum (DS) (Jackson Immunoresearch Lab. Inc., West Grove, PA, USA) and 1% BSA (fraction V; Sigma Immunochemicals, St. Louis, MO, USA) for 1 hour at room temperature. Following extensive washes in PBS (0.2% DS, 0.1% BSA), sections were incubated for 1 hour at room temperature with 20  $\mu$ g/ml of either CM6, or isotype matched mouse IgGs, used as control reference for specificity of CM6 antibody. After several washes in PBS (0.2% DS, 0.1% BSA), sections were incubated with an FITC-conjugated affinity-purified donkey anti-mouse secondary antibody (Jackson Immunoresearch Lab. Inc., West Grove, PA, USA) for 1 hour at room temperature. Following six washes of 5 minutes each with PBS (0.2% DS, 0.1% BSA), sections were mounted in slow fade medium and viewed on a Zeiss Axiovert 35M microscope (Carl Zeiss, Thornwood, NY, USA), using a 40X 1.3 NA objective lens, equipped with a laser scanning confocal attachment (MRC-1024, Bio-Rad Laboratories, Cambridge, MA, USA). Fluorescent images were collected by using an argon/krypton mixed gas laser. Composite images were generated using Adobe Photoshop, and printed on a Tektronix Phaser II-SDX (Tektronix, Inc., Beaverton, OR, USA).

#### *Adhesion assays*

Untreated 96 well plates (Sarstedt, Newton, NC) were coated for two hours at room temperature with rat or mouse laminin-1 (Gibco), human laminin-2 (placental laminin, Gibco), anti-Ln-5 monoclonal antibodies (all at 20  $\mu$ g/ml), Ln-5 (0.3  $\mu$ g/ml, kindly provided by Dr. M. Fitchmun, Desmos, Inc., San Diego, CA), or with human fibronectin or human vitronectin (both at 40  $\mu$ g/ml, Gibco). All proteins were diluted in 100 mM carbonate buffer, pH 9.3. Plates were then washed twice with phosphate buffered saline (PBS) containing 0.2% Tween 20 (PBST) and blocked overnight at 4° C with blotto (5% nonfat dried milk in PBST). Following two washes with PBST, wells containing anti-Ln-5 antibodies were incubated for 1 hour at room temperature with 804G cell conditioned medium, thereby allowing for 'capture' of soluble Ln-5, then washed twice with PBST. For CM6 antibody blocking experiments, wells were incubated with 50  $\mu$ g/ml of blocking antibodies diluted in blotto. As controls, wells were blocked with blotto alone, irrelevant antibody MOPC 31c, or anti-Ln-5 monoclonal antibody FM3. Wells were washed twice with PBST.

In some experiments, cells were allowed to attach to 804G cell matrix or wells coated with 804G cell conditioned medium. To prepare 804G cell matrix, cells were grown to confluency in Sarstedt 96 well plates, the culture medium was removed, and the cells were washed in sterile PBS. The cells were removed according to the method of Gospodarowicz [36] by incubating them 2  $\times$  5 minutes in 20 mM sterile NH<sub>4</sub>OH. The wells were extensively washed with PBS and distilled water and blocked with blotto as described above. Additional wells were coated for 2 hours with 804G cell conditioned medium, then washed and blocked as described above.

Cells were collected by brief trypsinization, blocked with either serum-containing medium or Trypsin Inhibitor solution (Clonetics), washed twice with DMEM/1% bovine serum albumin (BSA), then plated ( $1.2 \times 10^5$ /well) in DMEM/1% BSA/25 mM HEPES, pH 7.2. For anti-integrin antibody blocking experiments, cells were incubated at room temperature with blocking antibodies

(20 µg/ml for P1B5, GoH3, and P4C10, 50 µg/ml for P1E6) for 30 minutes before addition to plates; blocking antibodies were present during plating. Plates were kept at 37° C in a humidified incubator containing 10% CO<sub>2</sub> for 30 minutes. To remove unbound cells, wells were then filled with PBS and the plates were inverted in a tank of PBS and allowed to gently shake for 15 minutes. Excess PBS was absorbed from the wells by inverting plates on paper towels. Bound cells were fixed in 3% paraformaldehyde/PBS, then stained with 0.5% crystal violet in 20% methanol/80% H<sub>2</sub>O. Wells were washed with water to remove excess dye, then cells were solubilized in 1% SDS and the amount of dye was quantitated using a Molecular Devices plate reader set to absorb at 595 nm.

#### *Transwell haptotactic migration assays*

Transwell filters (8.0 µm pore size, Costar, Cambridge MA) were coated for 4 hours with identical concentrations of ECM proteins used in adhesion assays, diluted in 100 mM carbonate buffer, pH 9.3. Separate filters were coated for 1 hour with mouse monoclonal antibody TR1, diluted in 100 mM carbonate buffer. Antibody-coated filters were blocked for 2 hours with blotto, then incubated for 1 hour with 804G cell conditioned medium, thereby allowing for 'capture' of Ln-5 on the filter. For CM6 antibody blocking experiments, filters were incubated with 50 µg/ml CM6 diluted in blotto. As a control, filters were blocked with blotto alone. Following two washes with PBST, filters were inverted and cells ( $6 \times 10^4$  cells/filter) were plated on the uncoated side in migration medium (DMEM/2 mM glutamine/1 mM sodium pyruvate). For anti-integrin antibody blocking experiments, cells were incubated with blocking antibodies (20 µg/ml for P1B5, GoH3, and P4C10, 50 µg/ml for P1E6) in migration medium for 30 minutes before plating on filters. Antibodies were also present in migration medium throughout the migration assay. Cells were maintained at 37° C in a humidified incubator containing 10% CO<sub>2</sub> for 18 hours, then filters were fixed and cells stained using the Diff-Quik stain kit (Baxter, McGaw Park, IL). The uncoated side of each

filter was wiped with a cotton-tipped applicator to remove cells that had not migrated through the filter. Filters were then cut from their supports, mounted on slides, and viewed under bright field optics. To quantitate migration, stained cells were counted in four fields (under 300 × magnification) from each of two filters for each condition. Results were expressed as the mean number of cells counted in each field ± the standard deviation.

#### *Colloidal gold uptake motility assays*

Colloidal gold motility assays were performed exactly as described by Albrecht-Buhler [37]. Colloidal gold particles coated on glass coverslips were coated with Ln-5 affinity-captured by TR1 as described for adhesion assays. As controls, coverslips coated with gold particles were blocked with blotto and incubated with 804G cell conditioned medium. Cells were collected as for cell adhesion assays and plated (5,000/well) in 6 well plates containing coated coverslips. After 18 hours, cells were fixed in 10% formalin/PBS, viewed under dark field microscopy, and photographed using Kodak Gold 200 color print film. Migration was quantitated by digitally scanning prints of photographic images (Scanjet IICx; Hewlett Packard, Palo Alto, CA, USA), and computing the black area (displaced gold) in scanned images using Adobe Photoshop 3.0 (Adobe Systems, Inc., Mountain View, CA, USA) running on a Quadra 950 computer (Apple Computer, Inc., Cupertino, CA, USA). The results were expressed as the ratio of displaced gold area to the total area of each image ± standard deviation (n = 3).

#### *FACS analysis*

Cells were trypsinized, blocked, and washed as for adhesion assays, then washed twice with ice cold FACS buffer (Hanks Buffered Saline Solution containing 5% fetal calf serum and 0.02% NaN<sub>3</sub>), with each wash followed by gentle centrifugation at 4° C (500 × g). All subsequent steps were performed at 4° C. Cells were then incubated for 1 hour with anti-

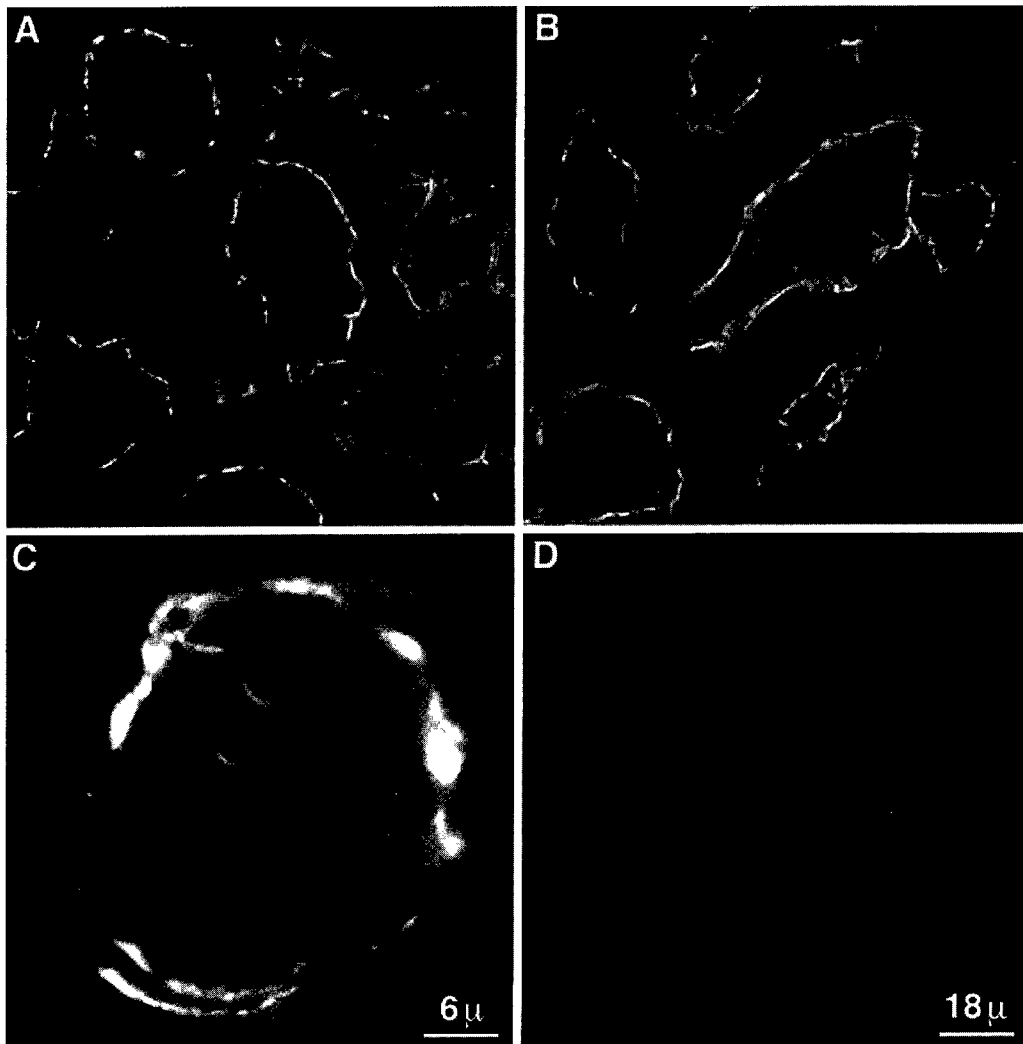

*Figure 1.* Laminin-5 is expressed in basal membranes of the breast epithelium. Panels A, B, and C show representative fields of a frozen section immunostained with anti-Ln-5 monoclonal antibody CM6, and observed with a confocal system. Note the clear and sharp immunofluorescent staining detected at the basal (basolateral) pole of breast epithelial cells by this mAb. Under the same confocal settings, no detectable signal was recorded in sections incubated with control isotype matched mouse IgGs (panel D). Images in panels A, B, and D were collected by a 40X (1.3 NA) objective, at a zoom factor 1, whereas the image in panel C was obtained at a zoom factor 3.

integrin antibodies diluted at the same concentrations used for adhesion and migration assays in FACS buffer, then washed twice with secondary antibody buffer (Hanks Buffered Saline Solution containing 5% goat serum and 0.02%  $\text{NaN}_3$ ). Cells were incubated for one hour with goat anti-mouse or goat anti-rat secondary antibodies coupled to fluorescein isothiocyanate (diluted 1:128 or 1:200, respectively, in secondary antibody buffer), washed twice with FACS buffer, then analyzed on a Beckton-Dickinson FACScan flow cytometer. As a con-

trol, cells were incubated with anti-mouse or anti-rat secondary antibodies only.

#### *Polymerase chain reaction*

Reverse transcriptase-polymerase chain reaction (RT-PCR) was carried out as described previously [38]. Briefly, poly(A) + RNA from HUMEK and MCF-7 cells was isolated using the Micro-FastTrack mRNA isolation kit (Invitrogen, San Diego, CA).

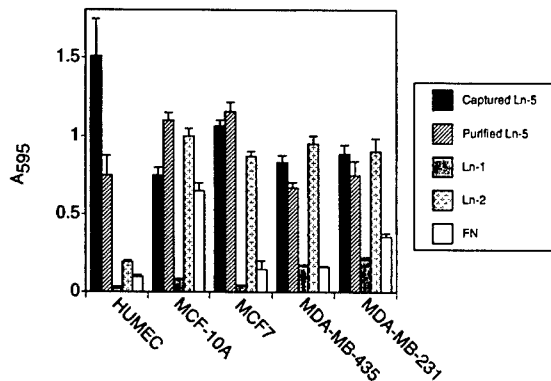

**Figure 2.** Normal breast epithelial cells preferentially bind Ln-5. Normal (HUMEC), immortalized (MCF-10A), and malignant cells were plated on the indicated ECM molecules for 30 minutes, gently washed to remove unattached cells, then fixed, stained, and quantitated as described in Materials and methods. Ln-5 = laminin-5; Ln-2 = human laminin-2; Fn = human fibronectin; Ln-1 = rat laminin-1. Data are presented as the statistical mean  $\pm$  standard deviation ( $n = 8$ ).

First-strand cDNA was prepared by using oligo (dT) primers and the RT-PCR kit (Stratagene, San Diego). Oligonucleotides were synthesized with a Cyclone Plus DNA synthesizer (Millipore, Bedford, MA). Primers for  $\alpha 3$  were: 3484, 5'-AAGC-CAAGTCTGAGACTGTG-3'; and 3485, 5'-GTAGTATTGGTCCCAGTCT-3', corresponding to nucleotides 2757–2776 and 3393–3413, respectively, of the human  $\alpha 3$  sequence [39].

## Results

### *Laminin 5 is expressed in breast*

To determine the distribution of Ln-5 in the mammary gland, we immunostained cryostat sections from snap-frozen mammary gland of an adult rat with CM6, a rat-specific monoclonal antibody against the  $\alpha 3$  chain of Ln-5 [35] (Figure 1). Sections were observed at a BioRad MRC 1024 confocal system. We found a bright fluorescent immunoreactivity at the basal (basolateral) pole of cells forming the mammary ductal epithelium with antibody CM6 (Figure 1, panels A, B, and at higher power in C), while control sections stained with isotype matched mouse IgGs were negative (Figure 1, panel D). This pattern of expression is suggestive of an

abundant representation of Ln-5 in basement membranes of mammary epithelium. In panel C, it can also be observed that Ln-5-specific immunoreactivity identifies the basal membrane of cellular structures reminiscent of myoepithelial cells.

### *Normal, immortalized, and MCF-7 malignant human breast epithelial cells bind Ln-5 through the $\alpha 3\beta 1$ integrin*

To investigate a potential role of Ln-5 in the organization of breast epithelium, we tested primary human breast epithelial cells (HUMEC); a spontaneously immortalized, non-malignant breast epithelial cell line (MCF-10A) [28]; and three malignant breast epithelial cell lines (MCF-7, MDA-MB-435, MDA-MB-231) [30–32] in rapid (30 minute) adhesion assays. Based on the percent surface area occupied by adherent cells, the plating efficiency of HUMECs and MCF-10A cells to purified Ln-5 and Ln-5 captured with a specific monoclonal antibody TR1 (Figure 2), 804G cell ECM, or 804G cell conditioned medium (not shown; see Materials and methods) was between 70–90% confluency per well. Since cell adhesion and migration (Figure 7A) was similar between purified Ln-5 and antibody captured Ln-5, and only small quantities of the purified material was available, Ln-5 captured by saturating amounts of monoclonal antibody TR1 [40] was utilized for further studies. Rapid adhesion of HUMECs to all other ECM molecules tested was relatively poor, less than 5% of the area of the well (Figure 2). The most active of these was laminin-2, which supported approximately 20% as much adhesion as Ln-5 (Figure 2). As controls, plates coated with antibody, the blocking agent 'blotto', or DMEM/10% FCS did not promote adhesion. In contrast to HUMECs, the MCF-10A, MCF-7, 435, and 231 cells adhered well to Ln-5, laminin-2, and fibronectin (Figure 2).

To investigate the contribution of specific integrins to normal and malignant cell adhesion to Ln-5, we used blocking monoclonal antibodies that recognize integrin chains reported to be involved in binding to laminins: PIE6 against  $\alpha 2$  [41], P1B5 against  $\alpha 3$  [41], GoH3 against  $\alpha 6$  [42], and P4C10

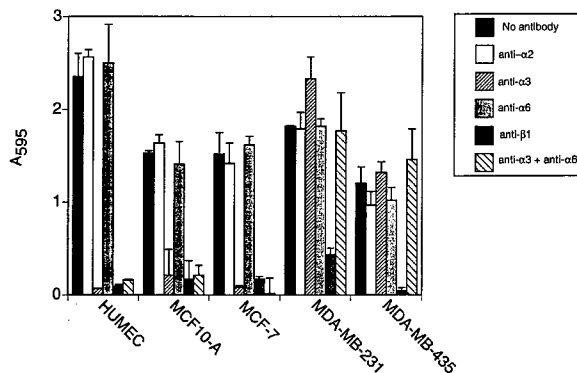

Figure 3. Inhibition of breast cell adhesion to Ln-5 by anti-integrin antibodies. Cells were plated on Ln-5 for 30 minutes in the presence of antibodies directed against the following integrin subunits: P1E6 =  $\alpha$ 2, P1B5 =  $\alpha$ 3, GoH3 =  $\alpha$ 6, P4C10 =  $\beta$ 1. Cells were then gently washed, fixed, stained, and quantitated as for Figure 2. Note that adhesion of HUMEC, MCF-10A, and MCF-7 cell lines was completely blocked by antibodies against  $\alpha$ 3 and  $\beta$ 1. Ln-5 = laminin-5.

against  $\beta$ 1 integrins [43]. In rapid adhesion assays, antibodies against  $\alpha$ 3 and  $\beta$ 1 integrin subunits reduced adhesion of HUMEC, MCF-10A, and MCF-7 cells by greater than 90% (Figure 3). In contrast, antibodies against  $\alpha$ 2 and  $\alpha$ 6 had no inhibitory effect on the adhesion of either cell type to Ln-5.

We used RT-PCR analysis to establish that HUMEC and MCF-7 cells express the A isoform of the  $\alpha$ 3 integrin receptor. Following RT-PCR we detected a 570 bp band corresponding to the  $\alpha$ 3A variant in both HUMECs and MCF-7 cells (Figure 4). We detected no 426 bp band corresponding to the  $\alpha$ 3B variant in either cell type. FACS analyses (Table 1) revealed that both cell types expressed nearly identical amounts of  $\alpha$ 3 integrin subunits on their sur-

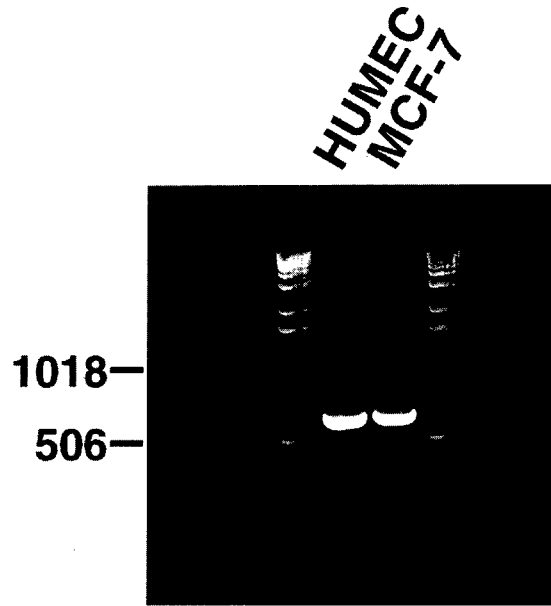

Figure 4. HUMEC and MCF-7 cells express identical isoforms of the  $\alpha$ 3 integrin. Expression of the  $\alpha$ 3A isoform was detected by RT-PCR of mRNA isolated from HUMEC and MCF-7 cells. Primers flanking the sequences encoding the alternatively spliced cytoplasmic domains amplified a 570 bp band corresponding to  $\alpha$ 3A, but no 426 bp band corresponding to  $\alpha$ 3B.

face. We conclude that normal and relatively weakly malignant MCF-7 cells utilize the same integrin receptor,  $\alpha$ 3 $\beta$ 1, to bind Ln-5.

Both MDA-MB-231 and MDA-MB-435 cell lines were inhibited from binding Ln-5 by antibodies against the  $\beta$ 1 integrin subunit, but antibodies against the  $\alpha$ 2,  $\alpha$ 3, and  $\alpha$ 6 integrin subunits failed to significantly interfere with adhesion of these cell types (Figure 3). Consistent with earlier studies [17], in control experiments the same concentra-

Table 1. Mammary epithelial cells express  $\alpha$ 2,  $\alpha$ 3,  $\alpha$ 6, and  $\beta$ 1 integrins. HUMEC, MCF-10A, MCF-7, MDA-MB-231, and MDA-MB-435 cells were stained with the monoclonal antibodies directed against the following integrin subunits: P1E6 =  $\alpha$ 2, P1B5 =  $\alpha$ 3, GoH3 =  $\alpha$ 6, P4C10 =  $\beta$ 1, followed by secondary antibodies conjugated to fluorescein, and analyzed by flow cytometry. As controls, cells were also stained with secondary antibodies alone. Note that all cell types expressed all four integrins tested. Results are expressed as mean fluorescence intensity (log scale, arbitrary units) of 10,000 sorted cells

Cell line	P1E6 ( $\alpha$ 2)	P1B5 ( $\alpha$ 3)	GoH3 ( $\alpha$ 6)	P4C10 ( $\beta$ 1)	Anti-mouse 2°	Anti-rat 2°
HUMEC	19.02	9.96	16.4	9.59	3.49	3.36
MCF-10A	23.45	21.54	26.52	17.64	2.37	2.13
MCF-7	18.28	22.29	20.21	25.4	4.82	4.81
MDA-MB-435	19.21	20.08	36.09	13.76	3.44	3.54
MDA-MB-231	17.05	21.65	36.29	19.92	3.61	3.65

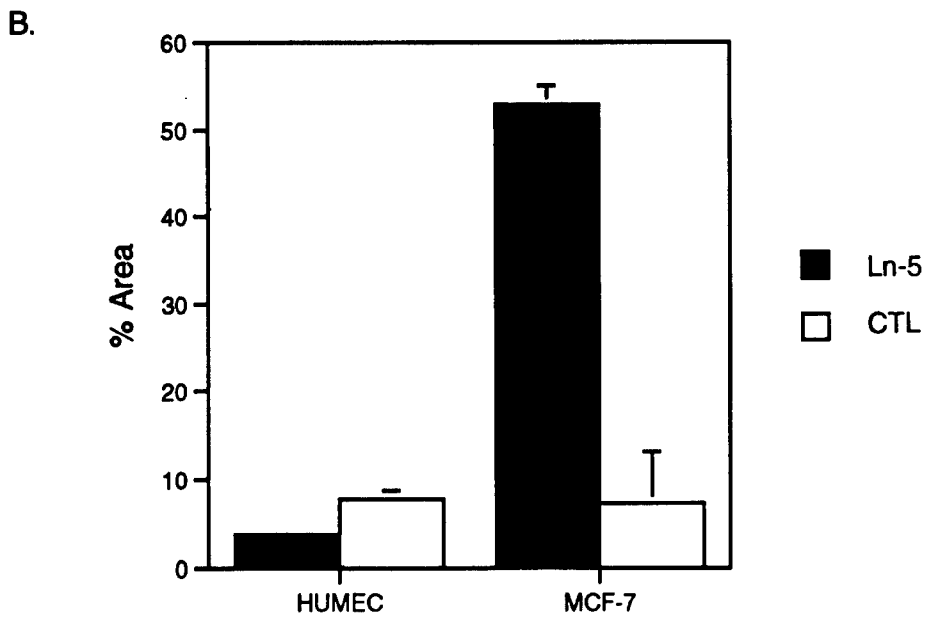
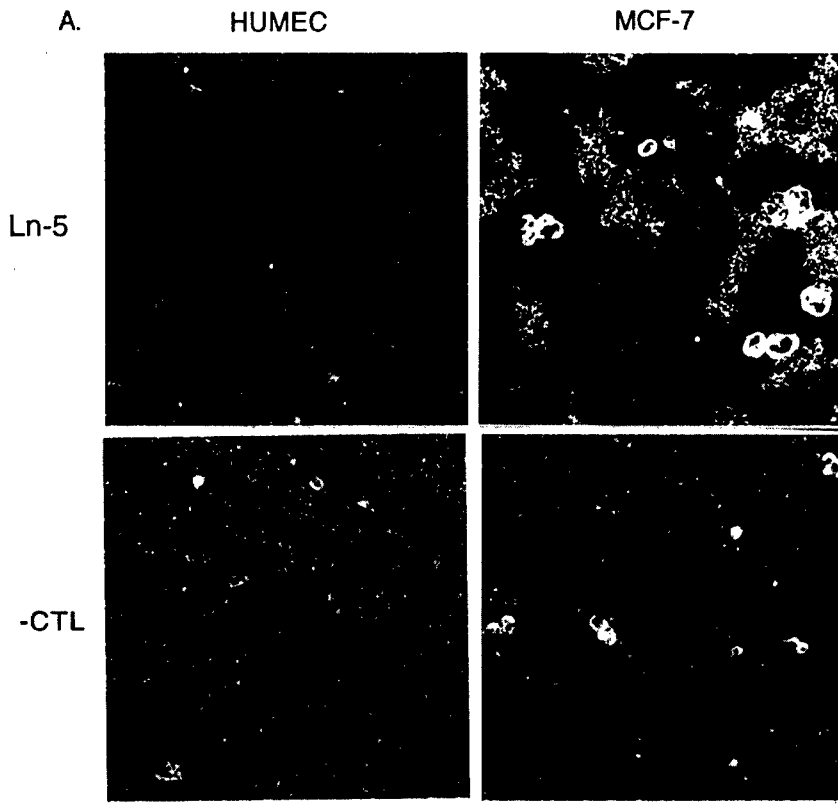

Figure 5. MCF-7 cells migrate approximately 10-fold more than HUMECs on Ln-5 coated colloidal gold. A. Dark field images of indicated cells plated on colloidal gold particles coated with Ln-5 or blotto (-CTL). Bar = 40  $\mu$ m. B. Quantitation of cell migration. Photographs of dark field microscopic fields as shown in panel A were digitized and scanned for black areas where cells had migrated. Values are expressed as the mean percentage of black area per field  $\pm$  standard deviation (n = 3).

tions of GoH3 antibody were able to block MDA-MB-231 and MDA-MB-435 cell adhesion to laminin-1, demonstrating that the  $\alpha 6 \beta 1$  and/or  $\alpha 6 \beta 4$  integrin is functionally expressed on the surface of these cells (not shown). Additionally, the anti- $\alpha 3$  blocking antibody (P1B5) did not inhibit MDA-MB-231 or MDA-MB-435 cell adhesion or migration on Ln-1 (not shown), further supporting the evidence that an  $\alpha 6$  integrin mediates Ln-1 binding in these cells. FACS analysis revealed that  $\alpha 2$ ,  $\alpha 3$ , and  $\alpha 6$  integrin were expressed on the surface of these cells (Table 1). Additional experiments using higher concentrations of anti- $\alpha$  subunit inhibitory antibodies (up to 50  $\mu\text{g/ml}$ ), inclusion of antibodies that block the function of  $\alpha 1$ ,  $\alpha 4$ ,  $\alpha 5$ , and  $\alpha V$  integrins (not shown), and combination of anti- $\alpha 3$  and anti- $\alpha 6$  blocking antibodies (Figure 3) failed to inhibit adhesion of either cell type to Ln-5. We conclude that the MDA-MB-231 and MDA-MB-435 cell lines differ from HUMECE, MCF-10A, and MCF-7 cells in that they do not use the  $\alpha 3 \beta 1$  integrin to bind Ln-5; rather, they use a  $\beta 1$  integrin that is resistant to  $\alpha 1$ ,  $\alpha 2$ ,  $\alpha 3$ ,  $\alpha 4$ ,  $\alpha 5$ ,  $\alpha 6$ , and  $\alpha V$  function blocking antibodies.

*MCF-7, but not HUMECE or MCF-10A cells, use  $\alpha 3 \beta 1$  integrin to spontaneously migrate on Ln-5*

To measure random cell motility following adhesion to Ln-5, cells were plated on colloidal gold particles coated with antibody-captured Ln-5. As cells randomly migrated they displaced the gold particles leaving behind a dark trail easily viewed under dark field optics [37]. MCF-7 cells were actively motile on Ln-5 coated gold particles. They formed rounded, multicellular aggregates, appeared to collect Ln-5-coated gold particles on their surfaces, and were loosely adherent to the glass. On control, BSA-coated particles, they instead spread, migrated poorly, and did not aggregate (Figure 5). MDA-MB-435, and MDA-MB-231 cells behaved similarly in this assay (not shown). In contrast, HUMECEs migrated on Ln-5-coated gold at background levels, approximately equal to that on control, BSA-coated gold particles (Figure 5).

To measure haptotactic migration on Ln-5, we

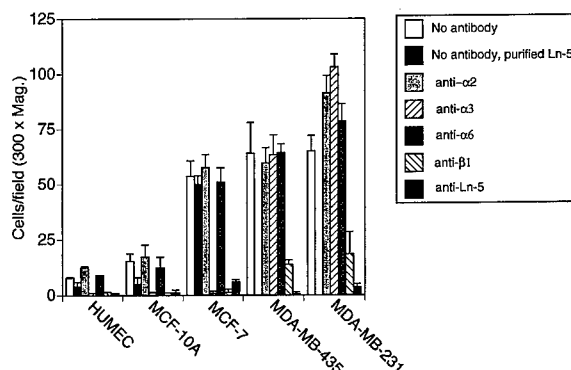

Figure 6. Inhibition of breast cell migration on Ln-5 by inhibitory antibodies. Mammary epithelial cells were plated on Transwell filters whose reverse sides were coated with Ln-5 (0.3  $\mu\text{g/ml}$ ), or TR1-captured Ln-5. Mammary epithelial cells were plated in the presence of either CM6 (anti-Ln-5) or antibodies directed against the indicated integrin subunits: P1E6 =  $\alpha 2$ , P1B5 =  $\alpha 3$ , GoH3 =  $\alpha 6$ , P4C10 =  $\beta 1$ . No inhibitory antibodies were included in control wells. Note that MDA-MB-435 and MDA-MB-231 cells were not tested on purified Ln-5 in this experiment. After 18 hours, cells were fixed and stained, and migration quantitated as described in Materials and methods. Results are expressed as statistical mean of number of cells counted per microscopic field (300  $\times$  magnification)  $\pm$  standard deviation ( $n = 8$ ).

plated normal and malignant cells on the upper side of Transwell filters (8  $\mu\text{m}$  pore diameter) coated on the underside with purified Ln-5 or Ln-5 captured by monoclonal antibody TR1. Consistent with our colloidal gold migration assays, MCF-7, MDA-MB-435, and MDA-MB-231 cells migrated very efficiently through Ln-5 coated filters (Figure 6). In contrast, HUMECE and MCF-10A cells did not: they were as migratory on Ln-5 coated filters as on control (BSA) coated filters (Figure 6). Consistent with these data, migration of MCF-7 cells was inhibited by the anti-Ln-5 antibody CM6. Inhibition by CM6 was expected since adhesion of MCF-7 (and MCF-10A) cells was also blocked by this antibody [44]. Antibodies directed against  $\alpha 3$  and  $\beta 1$  integrins also blocked migration, while antibodies directed against a  $\alpha 2$  or  $\alpha 6$  integrins had no effect (Figure 6). Migration of MDA-MB-435 and MDA-MB-231 cells was inhibited only by CM6 and antibodies against  $\beta 1$  integrin: none of the antibodies against  $\alpha$  subunits blocked migration.

In summary, both normal and MCF-7 cells adhere efficiently to Ln-5 through the  $\alpha 3 \beta 1$  integrin receptor, while MDA-MB-435 and MDA-MB-231

cells use an unidentified,  $\beta 1$ -containing receptor. However, HMECs and MCF-10A cells are statically adherent, whereas MCF-7, MDA-MB-435, and MDA-MB-231 cells actively migrate on Ln-5, so that the same receptor is responsible for these distinct behaviors in normal and MCF-7 cells.

## Discussion

We examined the contribution of Ln-5 to adhesion and migration of normal and malignant breast epithelial cells in *in vitro* assays using integrin-specific inhibitory antibodies and purified Ln-5 under defined, serum-free conditions. This approach provided an advantage over previous *in vivo* metastasis studies and *in vitro* studies using 'reconstituted basement membrane' (e.g., Matrigel) [45-49] in that it allowed us to examine the interactions between a single, non-denatured ECM protein and its integrin receptors.

One striking finding was that Ln-5 was more adhesive for normal breast epithelial cells than all other ECM molecules tested, including other laminin isoforms present in breast basement membrane; this preferential adhesiveness was not true for the malignant cell lines. This is somewhat surprising because laminin-1 in particular has been reported to play a significant role in breast cell growth and differentiation in *in vitro* models [50]. These findings, combined with the observation that Ln-5 supports branching morphogenesis of MCF-10A cells *in vitro* [51], our localization of Ln-5 to the basement membrane of normal rat breast gland (Figure 1), and detection of Ln-5 in secreted matrix of HMEC and

MCF-10A cells (not shown), argue strongly that preferential adhesion to Ln-5, particularly through the  $\alpha 3\beta 1$  integrin, plays a critical role in maintenance of normal breast epithelium.

Although the integrin receptor  $\alpha 6\beta 4$  functions as a receptor for Ln-5 [52] and is expressed in breast epithelium [53], our data suggest that it does not play a role in rapid (30 minute) adhesion to Ln-5 or migration on Ln-5 in these cells. However, these data do not discount the possibility that  $\alpha 6\beta 4$  may contribute to formation of long-term, stable adhesion complexes such as hemidesmosomes in these cells [54].

Integrin-mediated adhesion to Ln-5 also appears to play a significant role in tumorigenesis. Laminin-5 has been localized to invading cancer cells in breast and other organs [55, 56], and malignant MCF-7 cells secrete Ln-5 and incorporate it into their basement membrane in culture. Our observation that Ln-5 stimulates both random motility and haptotactic migration through the  $\alpha 3\beta 1$  integrin in MCF-7 cells and through a different, unidentified integrin(s) in MDA-MB-435 and MDA-MB-231 cells suggests that Ln-5 may also play a role in invasion and metastasis.

How can such divergent cellular phenotypes as static adhesion in normal and immortalized cells and spontaneous migration in malignant cells result after binding Ln-5 through the same receptor, the integrin  $\alpha 3\beta 1$ ? Although previous studies have identified changes in expression of integrin subunits in malignant tumors, no conclusive marker for malignant transformation in breast has been identified. Inherent in many of these studies is the assumption that these integrins are fully and/or equal-

Table 2. *In vitro* growth, adhesion, and migration behavior of primary (HMEC), immortalized (MCF-10A), and three malignant breast epithelial cells that exhibit different degrees of metastatic potential (MDA-MB-435>MDA-MB-231>MCF-7). This table illustrates the following three trends: 1) Continuously proliferating cells lose preferential adhesion to laminin-5; 2) Malignant cells are constitutively migratory on laminin-5; 3) The most malignant cells abandon  $\alpha 3\beta 1$  integrin as the adhesive and migratory receptor for laminin-5

	HMEC	MCF-10A	MCF-7	MDA-MB-231	MDA-MB-435
Continual growth in culture	-	+	+	+	+
Preferential adhesion to laminin-5	+	-	-	-	-
Constitutive, random migration on laminin-5	-	n/d	+	+	+
Constitutive, haptotactic migration on laminin-5	-	-	+	+	+
$\alpha 3\beta 1$ as laminin-5 receptor	+	+	+	-	-

ly functional when expressed on the cell surface. As a result, integrins that are expressed at approximately equal levels in normal and malignant cells may be overlooked as potential participants in the mechanism of malignant transformation.

Instead, we hypothesize that the  $\alpha 3\beta 1$  integrin may function differently in normal and malignant cells. We therefore propose that  $\alpha 3\beta 1$  integrin-mediated, strong adhesion to Ln-5, results in no haptotactic migration, no random motility, and may be a defining characteristic of normal breast epithelium.

When the five cell lines used in this study are ranked according to growth characteristics *in vitro* and reported metastatic potential, and scored for behaviors on Ln-5 such as rapid adhesion, static adhesion, integrin receptor, random motility, and haptotactic migration, a striking pattern emerges (Table 2): While all cells share the ability to bind Ln-5, the preference of Ln-5 as an adhesive substrate decreases as cells become more malignant. Concomitant with this rise in indiscriminate adhesion is the appearance of constitutive migration and a conversion from the  $\alpha 3\beta 1$  integrin to a different  $\beta 1$  integrin as the Ln-5 receptor. Interestingly, these changes do not occur simultaneously: MCF-7 cells use  $\alpha 3\beta 1$  as a Ln-5 receptor but they are constitutively migratory on Ln-5. Also, this conversion to a new integrin receptor occurs in the most malignant cell lines despite the fact that they express  $\alpha 3$  integrin on their surface.

Based on these observations, we propose a simplified model for malignant progression in breast: In virgin breast, normal (primary) and non-malignant (benign) cells interacting with Ln-5 in the duct basement membrane via integrin  $\alpha 3\beta 1$ , remain statically adherent. In our model, during pregnancy and lactation, breast epithelial cells proliferate and migrate on Ln-5 to form expanded acini via  $\alpha 3\beta 1$  integrin; this rearrangement of tissue architecture requires activation of intracellular signalling events that convert epithelial cells from stationary to migratory phenotypes and may modify the activation state of  $\alpha 3\beta 1$ . Early stages of malignant progression include constitutive activation of these signalling pathways, which give rise to continually migrating cells. Later stages of malignant progression involve conversion from  $\alpha 3\beta 1$  to a different  $\beta 1$  integrin, and

perhaps activation of different signalling pathways. Our observation that more aggressive malignant cell lines use a different  $\beta 1$  integrin(s) to bind and migrate on Ln-5 suggests that the conversion from static adhesion to migration through the  $\alpha 3\beta 1$  integrin may therefore represent an early event in malignant progression, and as such, may provide a significant marker for early detection of breast cancer.

#### Acknowledgements

We thank Wender Hwang and Terra Sorensen in the Quaranta lab, and Gina Cruz and Lisa Starr at Desmos, Inc. for expert technical assistance. Supported by grants from the Department of the Army of the United States (DAMD17-94-J-4138 to G.E. Plopper; DAMD17-94-J-4155 to S.Z. Domanico), and National Institutes of Health (GM46902 to V. Quaranta).

#### References

1. Hynes RO: Integrins: Versatility, modulation and signaling in cell adhesion. *Cell* 69: 11-25, 1992
2. Craig SW, Johnson RP: Assembly of focal adhesions: progress, paradigms, and portents. *Curr Opin Cell Biol* 8: 74-85, 1996
3. Schwartz MA, Schaller MA, Ginsberg MH: Integrins: Emerging paradigms of signal transduction. *Annu Rev Cell Dev Biol* 11: 549-599, 1995
4. Lauffenburger DA, Horwitz AF: Cell migration: a physically integrated molecular process. [Review]. *Cell* 84: 359-369, 1996
5. Huttenlocher A, Sandborg RR, Horwitz AF: Adhesion in cell migration. [Review]. *Curr Opin Cell Biol* 7: 697-706, 1995
6. Magro G, Lanzafame S, Colombatti A: Immunohistochemical staining patterns of type VI collagen in the normal, hyperplastic, and neoplastic adult male breast. *Pathologica* 86: 142-145, 1994
7. Christensen L: The distribution of fibronectin, laminin and tetranectin in human breast cancer with special attention to the extracellular matrix. [Review]. *APMIS Suppl* 26: 1-39, 1992
8. Coopman P, Verhasselt B, Bracke M, De Bruyne G, Castrovano V, Sobel M, Foidart JM, Van Roy F, Mareel M: Arrest of MCF-7 cell migration by laminin *in vitro*: possible mechanisms. *Clin Exp Metastasis* 9: 469-484, 1991
9. D'Ardenne AJ, Richman PI, Horton MA, McAulay AE, Jor-

- dan S: Co-ordinate expression of the alpha-6 integrin laminin receptor sub-unit and laminin in breast cancer. *J Pathol* 165: 213-220, 1991
10. Yoshida T, Ishihara A, Hirokawa Y, Kusakabe M, Sakakura T: Tenascin in breast cancer development – is epithelial tenascin a marker for poor prognosis? [Review]. *Cancer Lett* 90: 65-73, 1995
  11. Jaskiewicz K, Chasen MR, Robson SC: Differential expression of extracellular matrix proteins and integrins in hepatocellular carcinoma and chronic liver disease. *Anticancer Res* 13: 2229-2237, 1993
  12. Shoji T, Kamiya T, Tsubura A, Hamada Y, Hatano T, Hioki K, Morii S: Tenascin staining positivity and the survival of patients with invasive breast carcinoma. *J Surg Res* 55: 295-297, 1993
  13. Moch H, Torhorst J, Durmuller U, Feichter GE, Sauter G, Gudat F: Comparative analysis of the expression of tenascin and established prognostic factors in human breast cancer. *Pathol Res Pract* 189: 510-514, 1993
  14. Narita T, Kawakami-Kimura N, Sato M, Matsuura N, Higashiyama S, Kannagi R: Alteration of integrins by heparin-binding EGF-like growth factor in human breast cancer cells. *Oncology* 53: 374-381, 1996
  15. Gui GP, Wells CA, Yeomans P, Jordan SE, Vinson GP, Carpenter R: Integrin expression in breast cancer cytology: a novel predictor of axillary metastasis. *Eur J Surg Oncol* 22: 254-258, 1996
  16. Tawil NJ, Gowri V, Djoneidi M, Nip J, Carbonetto S, Brodt P: Integrin alpha 3 beta 1 can promote adhesion and spreading of metastatic breast carcinoma cells on the lymph node stroma. *Int J Cancer* 66: 703-710, 1996
  17. Shaw LM, Chao C, Wewer UM, Mercurio AM: Function of the integrin alpha 6 beta 1 in metastatic breast carcinoma cells assessed by expression of a dominant-negative receptor. *Cancer Res* 56: 959-963, 1996
  18. Maemura M, Akiyama SK, Woods VL Jr, Dickson RB: Expression and ligand binding of alpha 2 beta 1 integrin on breast carcinoma cells. *Clin Exp Metastasis* 13: 223-235, 1995
  19. Glukhova M, Kotliansky V, Sastre X, Thiery JP: Adhesion systems in normal breast and in invasive breast carcinoma. *Am J Pathol* 146: 706-716, 1995
  20. Friedrichs K, Ruiz P, Franke F, Gille I, Terpe HJ, Imhof BA: High expression level of alpha 6 integrin in human breast carcinoma is correlated with reduced survival. *Cancer Res* 55: 901-906, 1995
  21. Gui GP, Wells CA, Browne PD, Yeomans P, Jordan S, Puddifoot JR, Carpenter R: Integrin expression in primary breast cancer and its relation to axillary nodal status. *Surgery* 117: 102-108, 1995
  22. Oda K, Itoh H, Utsunomiya H, Itoh J, Osamura RY, Tokuda Y, Kubota M: Bio-histochemical aspects of integrins (alpha 2 beta 1, alpha 6 beta 1) in invasive mammary carcinomas: an immunohistochemical study. *Pathol Int* 44: 435-441, 1994
  23. Arihiro K, Inai K, Kurihara K, Takeda S, Khatun N, Kuroi K, Toge T: A role of VLA-6 laminin receptor in invasion of breast carcinoma. *Acta Pathol Jpn* 43: 662-669, 1993
  24. Sager R, Anisowicz A, Neveu M, Liang P, Sotiropoulou G: Identification by differential display of alpha 6 integrin as a candidate tumor suppressor gene. *Faseb J* 7: 964-970, 1993
  25. Jones JL, Critchley DR, Walker RA: Alteration of stromal protein and integrin expression in breast – a marker of pre-malignant change. *J Pathol* 167: 399-406, 1992
  26. Natali PG, Nicotra MR, Botti C, Mottolese M, Bigotti A, Segatto O: Changes in expression of alpha 6/beta 4 integrin heterodimer in primary and metastatic breast cancer. *Br J Cancer* 66: 318-322, 1992
  27. Koukoulis GK, Virtanen I, Korhonen M, Laitinen L, Quaranta V, Gould VE: Immunohistochemical localization of integrins in the normal, hyperplastic and neoplastic breast: Correlation with their functions as receptor and cell adhesion molecules. *Am J Pathol* 139: 787-799, 1991
  28. Soule HD, Maloney TM, Wolman SR, Peterson WD Jr, Brenz R, McGrath CMR, Pauley RJ, Jones RF, Brooks SC: Isolation and characterization of a spontaneously immortalized human breast epithelial cell line, MCF-10. *Cancer Res* 50: 6075-6086, 1990
  29. Band V, Sager R: Distinctive traits of normal and tumor-derived human mammary epithelial cells expressed in a medium that supports long-term growth of both cell types. *Proc Natl Acad Sci USA* 86: 1249-1253, 1989
  30. Gelmann EP, Thompson EW, Sommers CL: Invasive and metastatic properties of MCF-7 cells and rasH-transfected MCF-7 cell lines. *Int J Cancer* 50: 665-669, 1992
  31. Price JE, Polyzos A, Zhang RD, Daniels LM: Tumorigenicity and metastasis of human breast carcinoma cell lines in nude mice. *Cancer Res* 50: 717-721, 1990
  32. Zhang RD, Fidler IJ, Price JE: Relative malignant potential of human breast carcinoma cell lines established from pleural effusions and a brain metastasis. *Invasion Metastasis* 11: 204-215, 1991
  33. Riddelle KS, Green KJ, Jones JCR: Formation of hemidesmosomes *in vitro* by a transformed rat bladder cell lines. *J Cell Biol* 112: 159-168, 1991
  34. Lehmann M, Rabenandrasana C, Tamura RN, Lissitzky JC, Quaranta V, Pinchon J, Marvaldi J: A monoclonal antibody inhibits adhesion to fibronectin and vitronectin of a colon carcinoma cell line and recognizes the integrins  $\alpha V\beta 3$ ,  $\alpha V\beta 5$  and  $\alpha V\beta 6$ . *Cancer Res* 54: 2102-2107, 1994
  35. Plopper G, Falk-Marzillier J, Glaser S, Fitchmun M, Giannelli G, Romano T, Jones JCR, Quaranta V: Changes in expression in monoclonal antibody epitopes on laminin-5r induced by cell contact. *J Cell Sci* 109: 1965-1973, 1996
  36. Gospodarowicz D: Preparation of extracellular matrices produced by cultured bovine corneal endothelial cells and PF-HR-9 endodermal cells: Their use in cell culture. In: Barnes DW, Sirbasku DA, Stao GH (eds) *Methods for Preparation of Media, Supplements and Substrata*. Alan R. Liss, Inc., New York, 1984, pp 275-293
  37. Albrecht-Buehler G: The phagokinetic tracks of 3T3 cells. *Cell* 11: 395-404, 1977

38. Tamura RN, Cooper HM, Collo G, Quaranta V: Cell-type specific integrin variants with alternative  $\alpha$  chain cytoplasmic domains. *Proc Natl Acad Sci USA* 88: 10183–10187, 1991
39. Takada Y, Murphy E, Pil P, Chen C, Ginsberg MH, Hemler ME: Molecular cloning and expression of the cDNA for alpha 3 subunit of human alpha 3 beta 1 (VLA-3), an integrin receptor for fibronectin laminin and collagen. *J Cell Biol* 115: 257–266, 1991
40. Quaranta V, Plopper GE: Integrins and laminins in tissue remodeling. *Kidney Int* 51: 1441–1446, 1997
41. Wayner EA, Carter WG, Piotrowicz RS, Kunicki TJ: The function of multiple extracellular matrix receptors in mediating cell adhesion to extracellular matrix: Preparation of monoclonal antibodies to the fibronectin receptor that specifically inhibit cell adhesion to fibronectin and react with platelet glycoproteins Ic–IIa. *J Cell Biol* 107: 1881–1891, 1989
42. Sonnenberg A, Janssen H, Hogervorst F, Calafat J, Hilgers J: A complex of platelet glycoproteins Ic and IIa identified by a rat monoclonal antibody. *J Biol Chem* 262: 10376–10383, 1987
43. Carter WG, Wayner EA, Bouchard TS, Kaur P: The role of integrins alpha 2 beta 1 and alpha 3 beta 1 in cell-cell and cell-substrate adhesion of human epidermal cells. *J Cell Biol* 110: 1387–1404, 1990
44. Giannelli G, Falk-Marzillier J, Schiraldi O, Stetler-Stevenson WG, Quaranta V: Induction of cell migration by matrix metalloprotease-2 cleavage of laminin-5. *Science* 277: 225–228, 1997
45. Mullen P, Ritchie A, Langdon SP, Miller WR: Effect of Matrigel on the tumorigenicity of human breast and ovarian carcinoma cell lines. *Int J Cancer* 67: 816–820, 1996
46. Noel A, Borcy V, Bracke M, Gilles C, Bernard J, Birembaut P, Mareel M, Foidart JM: Heterotransplantation of primary and established human tumour cells in nude mice. *Anticancer Res* 15: 1–7, 1995
47. Bao L, Matsumura Y, Baban D, Sun Y, Tarin D: Effects of inoculation site and Matrigel on growth and metastasis of human breast cancer cells. *Br J Cancer* 70: 228–232, 1994
48. Mehta RR, Graves JM, Hart GD, Shilkaitis A, Das Gupta TK: Growth and metastasis of human breast carcinomas with Matrigel in athymic mice. *Breast Cancer Res Treat* 25: 65–71, 1993
49. Bae SN, Arand G, Azzam H, Pavaasant P, Torri J, Frandsen TL, Thompson EW: Molecular and cellular analysis of basement membrane invasion by human breast cancer cells in Matrigel-based *in vitro* assays. *Breast Cancer Res Treat* 24: 241–255, 1993
50. Lelievre S, Weaver VM, Bissell MJ: Extracellular matrix signaling from the cellular membrane skeleton to the nuclear skeleton: a model of gene regulation. [Review]. *Recent Prog Horm Res* 51: 417–432, 1996
51. Stahl S, Weitzman S, Jones JCR: The role of laminin-5 and its receptors in mammary epithelial cell branching morphogenesis. *J Cell Sci* 110: 55–63, 1997
52. Niessen CM, Hogervorst F, Jaspars LH, de Melker AA, Delwel GO, Kuikman I, Sonnenberg A: The alpha 6 beta 4 integrin is a receptor for both laminin and kalinin. *Exp Cell Res* 211: 360–367, 1994
53. Anbazhagan R, Bartkova J, Stamp G, Pignatelli M, Gusteron B: Expression of integrin subunits in the human infant breast correlates with morphogenesis and differentiation. *J Pathol* 176: 227–232, 1995
54. Xia Y, Gil SG, Carter WG: Anchorage mediated by integrin alpha 6 beta 4 to laminin 5 (epiligrin) regulates tyrosine phosphorylation of a membrane-associated 80-kD protein. *J Cell Biol* 132: 727–740, 1996
55. Pyke C, Salo S, Ralfkiaer E, Romer J, Dano K, Tryggvason K: Laminin-5 is a marker of invading cancer cells in some human carcinomas and is coexpressed with the receptor for urokinase plasminogen activator in budding cancer cells in colon adenocarcinomas. *Cancer Res* 55: 4132–4139, 1995
56. Pyke C, Romer J, Kallunki P, Lund LR, Ralfkiaer E, Dano K, Tryggvason K: The gamma 2 chain of kalinin/laminin 5 is preferentially expressed in invading malignant cells in human cancers. *Am J Pathol* 145: 782–791, 1994

Title: Perillyl alcohol induces redistribution of RhoA and cytoskeletal disorganization in human breast cells

Authors: Johanna E. Wagner<sup>1</sup>, Janice L. Huff<sup>1</sup>, William L. Rust<sup>1</sup>, Karl Kingsley<sup>1</sup>, and George E. Plopper<sup>2,3</sup>

Affiliations:

1 UNLV Cancer Institute and Department of Biological Sciences, University of Nevada, Las Vegas

2 Corresponding Author

3 Department of Biology, Rensselaer Polytechnic Institute, 110 8th Street, Troy NY 12180-3590

telephone (518) 276-8288, fax (518) 276-2162, email: ploppg@rpi.edu

Correspondence:

George Plopper, Ph.D.  
Department of Biology  
Rensselaer Polytechnic Institute  
110 8<sup>th</sup> Street  
Troy NY 12180-3590  
(518) 276-8288 phone  
(518) 276-2162 fax  
ploppg@rpi.edu

### **Abstract**

We recently reported that perillyl alcohol (POH) inhibits breast cell migration. To determine its effects on regulation of the actin cytoskeleton, we examined the effects of POH exposure on RhoA protein expression and distribution, actin filament formation, and focal adhesion integrity in non-tumorigenic (MCF-10A) and malignant (MDA-MB-435) human breast cells. Baseline expression of RhoA was greater in MCF-10A cells than in MDA-MB-435 cells, and did not change in either cell line upon 18 hour exposure to POH. During this time course in MCF-10A cells, RhoA redistributed from the detergent (membrane) to the aqueous (cytosol) phase in Triton X-114 extraction assays; in MDA-MB-435 cells, RhoA partitioned into the aqueous phase at all time points. POH exposure resulted in complete disassembly of stress fiber and focal adhesion complex formation in both cell types, consistent with a loss of RhoA protein function.

## Introduction

Small G-proteins play an important role in the metastatic behavior of tumor cells (1). Protein isoprenylation, a form of post-translational modification, allows these proteins to associate with the plasma membrane where they activate various targets for a wide range of biological activity—contractility, adhesion, cytokinesis, proliferation, neoplastic transformation and apoptosis (2). Therefore, blocking the activation of low molecular weight GTPases by inhibiting their isoprenylation could reduce metastasis (3). The monoterpene perillyl alcohol (POH) has been shown to block isoprenylation of RhoA, a small GTPase involved in a migration-signaling pathway, by competitively inhibiting the enzyme type I geranylgeranyl-protein transferase (GGPTase) (4-5). However, the specifics of this inhibition vary among cell types and cellular environments (6). POH's mode of action in normal and malignant human breast cells is unknown.

We have recently reported that POH inhibits the migration of non-malignant and malignant breast cells (Wagner et al., manuscript submitted). One likely class of POH targets in these cells is the Rho family of small GTPases, which relay extracellular stimuli such as mitogen-activated and integrin-derived signals, and organize the actin cytoskeleton (7). Microinjection with activated and dominant negative Rho family members leads to a defined hierarchy of GTPase activation: activated Cdc42 activates Rac1, which then activates RhoA (8-9). Rac drives the development of lamellipodia, whereas Cdc42 stimulates the polymerization of actin at the leading edge to form long, thin extensions called

filopodia (8-9). RhoA activation leads to the production of large, highly organized focal adhesion complexes and actin stress fibers (8-9).

Activated RhoA binds to and activates the serine/threonine kinase Rho-kinase (ROK $\alpha$ ) (8). This kinase regulates cell contractility by indirectly increasing phosphorylation of myosin light chain through the inhibition of myosin phosphatase activity (10) and by direct phosphorylation of myosin light chain, independently of myosin light chain kinase (11). Overall, through this pathway, RhoA activation results in bundling of actin filament into stress fibers and clustering of integrins into focal adhesions. This membrane-cytoskeleton interaction has been reported to increase invasiveness in tumor cells from liver and breast tissue (12-13). Additionally, the level of RhoA expression has been reported to be several times higher in tumors than in surrounding normal tissue (12).

The objective of this study was to determine whether the isoprenylation of RhoA protein in POH treated breast cancer (MDA-MB-435) and non-cancer (MCF-10A) cells was altered. We hypothesized that the decreased migration observed in POH-treated MCF-10A and MDA-MB-435 cells would be the result of the translocation of RhoA to the cytosol, thus impairing its migration signaling pathway. By western blot, we found that the RhoA protein of exposed cells accumulated in the aqueous phase following lysing with Triton X-114. This result suggests that RhoA isoprenylation in MCF-10A and MDA-MB-435 cells is affected by POH and that this may account for the observed decreased in MCF-10A migration previously reported. Furthermore, the morphological loss of actin

stress fiber and focal adhesion formation following exposure of MCF-10A to POH indicates loss of RhoA function.

## Materials and Methods

### *Materials*

MCF-10A and MDA-MB-435 cells were purchased from American Type Culture Collection. Epidermal growth factor, cholera toxin, and insulin were obtained from Calbiochem (La Jolla, CA). Hydrocortisone was purchased from Sigma-Aldrich Chemicals (St. Louis, MO). Horse serum was purchased from Irvine Scientific (Santa Ana, CA). POH was purchased from Aldrich Chemical Co. (Milwaukee, WI). The MicroBCA protein assay kit was purchased from Pierce (Rockford, IL). Immobilon-P transfer membrane is from Millipore (Bedford, MA). Mouse anti-human RhoA IgG, mouse anti-human vinculin IgG and secondary goat anti-mouse IgG-AP were purchased from Santa Cruz Biotechnology (Santa Cruz, CA). CDP-star chemiluminescence reagent was purchased from Dupont-New England Nuclear (Boston, MA). Cell culture plates were purchased from VWR (Plainfield, NJ). Triton X-100 and X-114 were purchased from Sigma-Aldrich Chemicals (St. Louis, MO). Goat anti-mouse rhodamine-conjugated IgG, FITC-phalloidin and ELF-97 Immunohistochemical Mounting Medium were purchased from Molecular Probes (Eugene, OR).

### *Cell culture*

Cells were grown in 75 cm<sup>2</sup> Falcon tissue-culture flasks obtained from VWR (Plainfield, NJ). Cells were maintained at 37°C and 5% CO<sub>2</sub> in humidified chambers. MCF-10A cells were maintained in AM media—1:1 mixture of Ham's F-12 medium and Dulbecco's Modified Eagle's Medium High Glucose with 2 mM

L-glutamine from Irvine Scientific (Santa Ana, CA) supplemented with the following: epidermal growth factor (20 ng/ml), cholera toxin (100 ng/ml), insulin (0.01 mg/ml), hydrocortisone (500 ng/ml) and 5% horse serum. MDA-MB-435 cells were maintained in RPMI Medium 1640 supplemented with 10% fetal bovine serum and 1% L-glutamine (29.2 mg/ml), penicillin G (10,000 units/ml) and streptomycin sulfate (10,000  $\mu$ g/ml) from Irvine Scientific (Santa Ana, CA). Cells were routinely passaged using trypsin/EDTA from Irvine Scientific (Santa Ana, CA).

#### *Western Analysis*

Subconfluent plates of MCF-10A and MDA-MB-435 cells treated with POH for 18 hours were washed in ice-cold PBS and lysed in ice-cold RIPA buffer and protein concentrations were determined by MicroBCA assay. Proteins were separated by 12% SDS-PAGE and transferred to Immobilon-P Transfer Membranes and processed for immunoblotting as previously described (14). Processed membranes incubated with primary antibody were then incubated with secondary goat anti-mouse IgG-AP and exposed to chemiluminescence reagent and developed on Kodak X-OMAT LS scientific imaging film.

#### *Separating Proteins into Aqueous and Detergent-Enriched Phases*

The isoprenylated and unprocessed forms of RhoA proteins were separated into the detergent-enriched phase and the aqueous phase of 1% Triton X-114 TBS (20 mM Tris and 150 mM NaCl, pH 7.5) buffer as described by

Gutierrez et al. (15). POH (18 hr)-treated and untreated control cells were washed in ice-cold PBS and lysed with ice-cold 1% Triton X-114 TBS buffer. The cell debris was pelleted by centrifugation and the supernatant was incubated at 37°C for 5 minutes. The turbid solution was centrifuged at 16,000 x g for 2 minutes, and the upper (aqueous) and the lower (detergent-enriched) phases were separated. Equal percentages of RhoA proteins in the aqueous phase and the detergent-enriched phase were analyzed by SDS-PAGE and western blot as described above.

#### *Immunohistochemistry*

Subconfluent MCF-10A and MDA-MB-435 cells plated on fibronectin-coated (20 µg/ml) coverslips in serum-containing media for 24 hr were washed in PBS and treated with POH for 18 hours. Cells were then washed in PBS, fixed in 4% paraformaldehyde, permeabilized in 0.3% Triton X-100 PBS, labeled with primary mouse anti-human vinculin antibody and doubled stained with secondary rhodamine-conjugated goat anti-mouse IgG antibody and FITC phalloidin after 30 minutes of incubation. Stained cells were analyzed with a Zeiss confocal microscope.

## Results and Discussion

We recently demonstrated a decrease in cell migration for the nontumorigenic human breast cell line MCF-10A after exposure to 0.5 mM POH (Wagner et al., manuscript submitted). Previous studies suggest that POH inhibits protein isoprenylation in several malignant and non-malignant cell lines (5, 16). POH has been shown to inhibit the enzymes farnesyl protein transferase and types I and II GGPTase that catalyze the protein isoprenylation of small G-proteins (4). Inhibition of these three enzymes in different cell lines, however, has not been uniform; especially with regard to farnesyl protein transferase activity (4, 17). Therefore, we looked for a possible link between the observed decrease in migration of MCF-10A cells and a change in activity of the small G-protein RhoA. RhoA is a GTPase that requires the addition of a 20-carbon isoprene group geranylgeranylpyrophosphate by the enzyme GGPTase for it to associate with the plasma membrane, where it participates in migration signaling pathways (9).

To investigate the whether POH decreases the isoprenylated RhoA levels by down-regulating protein synthesis rather than by inhibiting type 1 GGPTase, we measured RhoA levels in MCF-10A and MDA-MB-435 cells treated with POH by western blot. After 18 hours of treatment there was no difference in protein levels between treated and untreated cells (Fig. 1), in agreement with previous studies (4).

There was however a difference in RhoA protein expression between cell lines: the non-tumorigenic MCF-10A cells express more RhoA protein compared to the MDA-MB-435 cancer cells (Fig. 1). This was surprising, because MDA-MB-

435 is a highly invasive breast cancer cell line, and it has been shown that other types of tumor cells express several times the amount of RhoA protein compared to their non-malignant counterparts (18). Additionally, cells overexpressing RhoA protein exhibit increased motility (12), yet MCF-10A cells are far less motile than MDA-MB-435 cells (19).

To confirm an effect of POH on RhoA protein isoprenylation in our two cell lines, we addressed the translocation of RhoA protein from the plasma membrane to the cytosol. The unprenylated form of RhoA protein cannot associate with the plasma membrane (20); therefore, upon exposure to POH RhoA should accumulate in the cytosol. Since POH inhibits type 1 GGPTase, we hypothesized that it would change the ratio of prenylated and unprenylated forms of RhoA protein. After separating proteins into aqueous (unprenylated, cytosolic) and detergent-enriched (prenylated, membrane-bound) phases of Triton X-114, RhoA was detected by western blot. After a 30 minute treatment (Fig 2) of MCF-10A cells, RhoA segregated exclusively into the detergent-enriched phase but shifted into the aqueous phase after 18 hours of POH exposure (Fig. 3). The high degree of RhoA membrane association at early times may be due to the cells recruiting RhoA to the plasma membrane as they reorganize their cytoskeleton to form focal adhesion complexes and stress fibers after adhering to the fibronectin-coated plates.

In MDA-MB-435 cells (Fig. 4), RhoA protein appeared in the detergent phase in control cells but also appeared in the aqueous phase after 30 minutes of POH exposure. This accumulation of RhoA protein in the aqueous phase

continued at 18 hours of POH exposure. Because MDA-MB-435 cells have a lower threshold of tolerance to POH exposure than MCF-10A cells (Wagner et al., manuscript submitted), it is possible that even short exposure times may induce proapoptotic pathways that result in RhoA deactivation and accumulation in the cytosol. Another possibility is that POH targets multiple pathways that control RhoA activation in these cells.

RhoA activated by serum growth factors can induce formation of stress fibers and focal adhesion complexes (21). The assembly and disassembly of focal adhesion complexes and concomitant cell spreading have been implicated in migration activities of tumor cells (22), and sublethal doses of POH block migration of MCF-10A cells (Wagner et al., manuscript submitted). We therefore sought to determine the effects of POH treatment on actin organization and focal adhesion assembly. As shown in Figure 5, MCF-10A cells plated for 18 hours in the presence of serum containing media contained numerous stress fibers and vinculin-containing focal adhesion complexes. When exposed to serum-free media alone for the same time period, MCF-10A cells showed a slight decrease in the number of stress fibers and focal adhesion complexes (Fig. 5). However, after 18 hours of treatment with POH in serum-free media, MCF-10A cells rounded up, and lost the majority of their stress fibers and focal adhesion complexes (Fig. 5). We also observed condensation of actin filaments and focal adhesion complex proteins within the center of treated cells, consistent with a loss of RhoA function. Treatment of MDA-MB-435 cells with POH over the same time course resulted in essentially identical results (Fig. 6). We were unable to identify a

noticeable change in the intracellular localization of RhoA protein by confocal microscopy, in that it localized to both the cell periphery and internal structures under POH exposure and control conditions (data not shown). It is likely that the Triton X-114 partitioning is more sensitive to membrane association than is microscopy.

Together, these data demonstrate that POH inhibits the membrane association of RhoA protein in both non-tumorigenic and malignant human breast cells, and suggest that this occurs by inhibiting the isoprenylation of RhoA by type 1 GGPTase. The resulting inactivation leads to loss of actin stress fibers and disassembly of the cytoskeletal machinery necessary for supporting cell migration. That this occurs in subtoxic doses suggests that POH treatment may be a candidate for prophylactic treatment of patients at risk for developing breast cancer.

### **Acknowledgements**

This work was supported by a career development grant (DAMD17-98-1-8325 to GEP) from the United States Army Breast Cancer Research Program.

## References

1. A. Chambers, A. Tuck, Ras-responsive genes and tumor metastasis, *Crit. Rev. Oncog.* 4 (1993) 95-114.
2. P. Aspenstrom, Effectors for the Rho GTPases, *Curr. Opin. Cell Biol.* 11 (1999) 95-102.
3. P. Matar, V.R. Rozados, M.M. Binda, E.A. Roggero, R.D. Bonfil, O.G. Scharovsky, Inhibitory effect of lovastatin on spontaneous metastases derived from a rat lymphoma, *Clin. Exp. Metastasis* 1 (1999) 19-25.
4. Z. Ren, C. Elson, M. Gould, Inhibition of type I and type II geranylgeranyl protein transferases by the monoterpene perillyl alcohol in NIH3T3 cells, *Biochem. Pharmacol.* 54 (1997) 113-120.
5. Z. Ren, M. Gould, Modulation of small G protein isoprenylation by anticancer monoterpenes in in situ mammary gland epithelial cells, *Carcinogenesis*. 19 (1998) 827-832.
6. R. Qui, J. Chen, D. Kirn, F. McCormick, M. Symons, An essential role for Rac in Ras transformation, *Nature* 374 (1995) 457-459.
7. N. Boudreau, P. Jones, Extracellular matrix and integrin signaling: the shape of things to come, *J. Biochem.* 339 (1999) 484-488.
8. A.R. Horwitz, J.T. Parsons, Cell migration—movin' on, *Science*. 286 (1999) 1102-1103.
9. L. Kjoller, A. Hall, Signaling to Rho GTPases, *Exp. Cell Res.* 253 (1999) 166-179.
10. N. Kimura, M. Ito, M. Amano, K. Chihara, Y. Fukata, M. Nakafuku, B. Yamamori, J. Feng, T. Nakano, K. Okawa, K. Iwamatsu, K. Kaibuchi, Regulation of myosin phosphatase by Rho and Rho-associated kinase (Rho-kinase), *Science* 273 (1996) 245-248.
11. M. Amano, M. Ito, K. Kimura, Y. Fukata, K. Chihara, T. Nakano, Y. Matsuura, K. Kaibuchi, Phosphorylation and activation of myosin by Rho-associated kinase (Rho-kinase). *J. Biol. Chem.* 271 (1996) 20246-20249.
12. K. Yoshioka, S. Nakamori, K. Itoh, Overexpression of small GTP-binding protein RhoA promotes invasion of tumor cells, *Cancer Res.* 59 (1999) 2004-2010.

13. L. Bourguignon, H. Zhu, L. Shao, D. Zhu, Y. Chen, Rho-kinase (ROK) promotes CD44<sub>v3,8-10</sub>-ankyrin interaction and tumor cell migration in metastatic breast cancer cells, *Cell Motil. Cytoskeleton* 43 (1999) 269-287.
14. D.L. Spector, R.D. Goldman, L.A. Leinwald, *Cells: A Laboratory Manual; Culture and Biochemical Analysis of Cells*. Cold Spring Harbor Lab. Press, NY, 1998, 3.1-3.12.
15. L. Gutierrez, A.I. Magee, C.J. Marshall, J.L. Hancock, Post-translational processing of p21<sup>ras</sup> is two-step and involves carboxyl-methylation and carboxy-terminal proteolysis, *EMBO J.* 8 (1989) 1093-1098.
16. P.L. Crowell, R.R. Chang, Z. Ren, C.E. Elson, M.N. Gould, Selective inhibition of isoprenylation of 21-26 kDa proteins by the anticarcinogen d-limonene and its metabolites, *J. Biol. Chem.* 266 (1991) 17679-17685.
17. N.E. Kohl, N.D. Mosser, S.J. deSolms, E.A. Guliani, D.L. Pompliano, S.L. Graham, R.L. Smith, E.M. Scolnick, A. Oliff, J. Gibbs, Selective inhibition of *ras*-dependent transformation by a farnesyltransferase inhibitor, *Science*. 260 (1993) 1934-1937.
18. S. Nakamori, S. Tamura, I. Arai, M. Kameyama, F. Furukawa, K. Yoshioka, M. Mukai, K. Shinkai, H. Akedo, Increased expression of RhoA p21 protein is involved in progression and metastasis of colorectal carcinoma. *Records of Advanced Gastroenterology and Carcinogenesis*, 1 (1996) 901-904.
19. G.E. Plopper, S. Domanico, W.B. Kioses, and V. Quaranta, Laminin-5 induced adhesion and migration in mammary epithelial cells: Differential role of  $\alpha 3 \beta 1$  integrin in normal and transformed cell types. *Breast Cancer Res. Treat.* 51 (1998) 57-69
20. P.J. Casey, M.C. Searbra, Protein prenyltransferases, *J. Biol. Chem.* 271 (1996) 5289-5292.
21. A. Ridley, A. Hall, The small GTP-binding protein rho regulates the assembly of focal adhesions and actin stress fibers in response to growth factors, *Cell* 70 (1992) 389-399.
22. E.C. Woodhouse, R.F. Chuaqui, L.A. Liotta, General mechanisms of metastasis, *Cancer* 80 (8 Suppl.) (1997) 1529-1537.

## Figure legends

Figure 1. POH treatment does not influence RhoA protein levels in human breast cells. Cells were incubated in POH for 18 hours. Cell lysates normalized for total protein amounts were then probed for RhoA protein levels by western blot. A, MCF-10A cells in minimal medium alone; B, MCF-10A cells in 0.5 mM POH; C, MDA-MB-435 cells in minimal medium alone; D, MDA-MB-435 cells in 0.3 mM POH. Migration of molecular weight markers shown at left.

Figure 2. RhoA partitions exclusively into the Triton X-114 detergent fraction of MCF-10A cells after 30 minutes of POH exposure. Cells were incubated in serum containing media plus 0.5 mM POH (lane A), serum-containing media alone (lane B), serum-free media alone (lane C), or serum-free medium plus 0.5 mM POH. RhoA was detected by western blot. Samples were normalized for equal cell number in each lane. Migration of molecular weight markers shown at left.

Figure 3. RhoA enters the Triton X-114 aqueous fraction of MCF-10A cells after 18 hours of POH exposure. Cells were incubated in serum-containing medium alone (lane A), serum-free medium alone (lane B), or serum-free medium plus 0.5 mM POH (lane C). RhoA was detected by western blot. Samples were normalized for equal cell number in each lane. Migration of molecular weight markers shown at left.

Figure 4. RhoA enters the Triton X-114 aqueous fraction of MDA-MB-435 cells after 30 minutes of POH exposure. Cells were incubated in serum-free medium for 30 minutes (lane A), minimal medium plus 0.3 mM POH for 30 minutes (lane B), serum-free medium for 18 hours (lane C), or serum-free medium plus 0.3 mM POH for 18 hours (lane D). Whole cell lysate (lane E) was included as a positive control. All lanes were normalized for equal cell number. RhoA was detected by western blot. Migration of molecular weight markers shown at left.

Figure 5. 18 hour exposure to POH disrupts the actin cytoskeleton and focal adhesion complex formation in MCF-10A cells. Cells were plated for 24 hours on fibronectin-coated coverslips then incubated for 18 hours in serum containing medium (A and D), serum-free medium (B and E), or serum-free medium containing 0.5 mM POH (C and F). Cells were stained with phalloidin for F-actin (A-C) and anti-vinculin antibody (D-F) and viewed with a confocal microscope. Bars in each panel = 50  $\mu$ m.

Figure 6. 18 hour exposure to POH disrupts the actin cytoskeleton and focal adhesion complex formation in MDA-MB-435 cells. Cells were plated for 24 hours on fibronectin-coated coverslips then incubated for 18 hours in serum containing medium (A and D), serum-free medium (B and E), or serum-free medium containing 0.5 mM POH (C and F). Cells were stained with phalloidin for F-actin (A-C) and anti-vinculin antibody (D-F) and viewed with a confocal

microscope. Bars in panels A,B,D,and E = 50  $\mu\text{m}$ ; bars in panels C and F = 20  $\mu\text{m}$ .

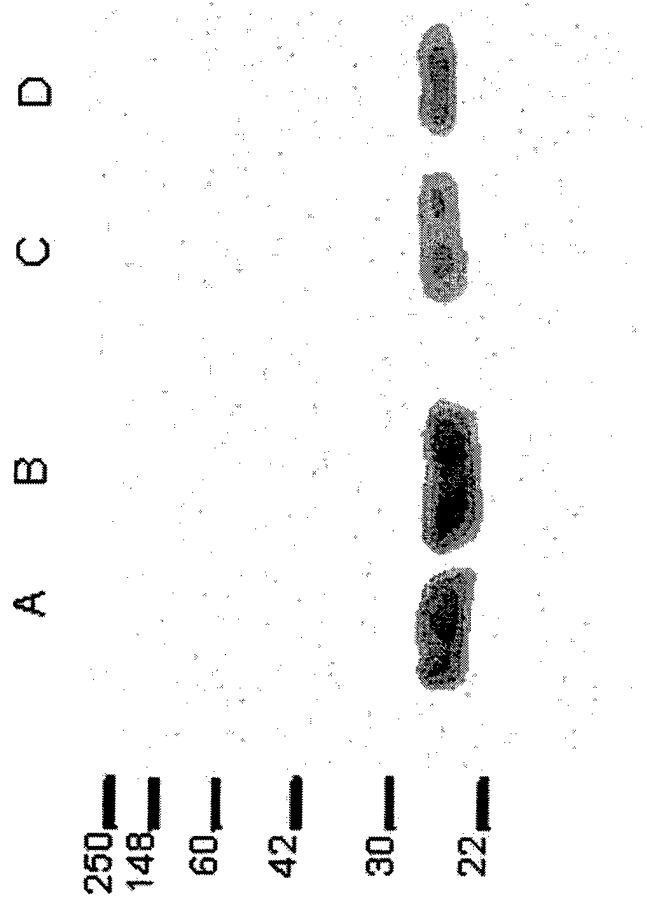

Figure 1

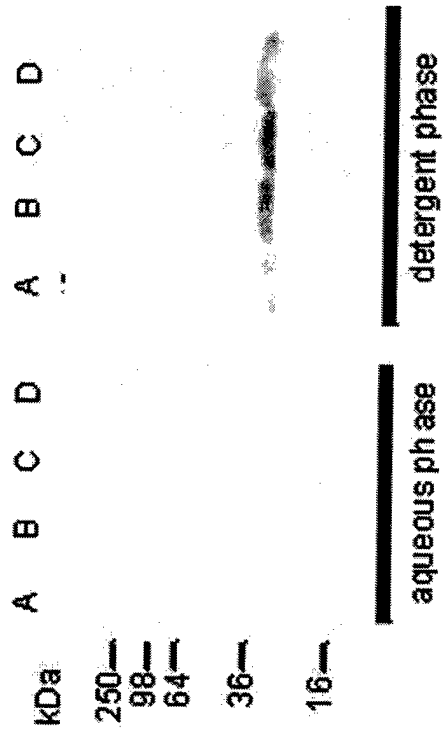

Figure 2

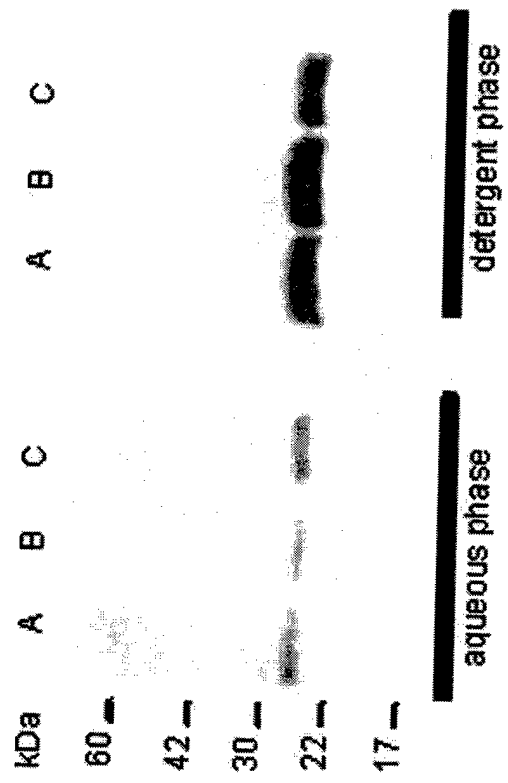

Figure 3

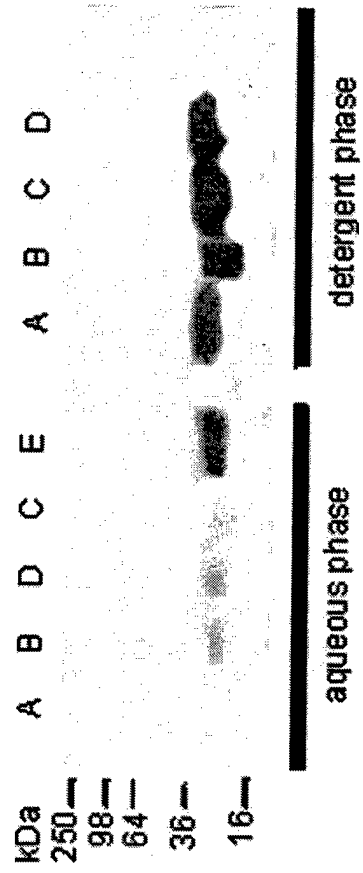

Figure 4

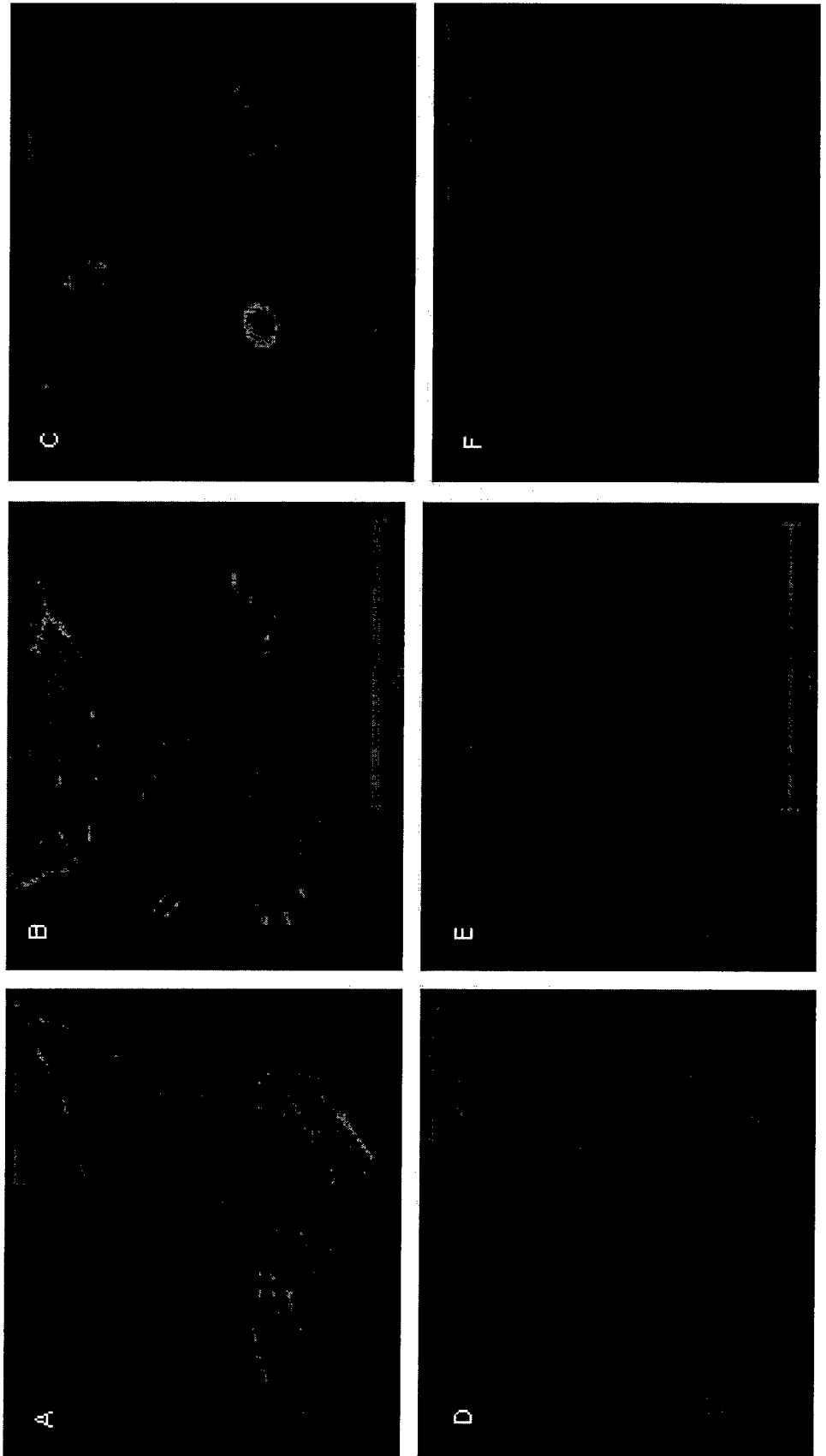

Figure 5

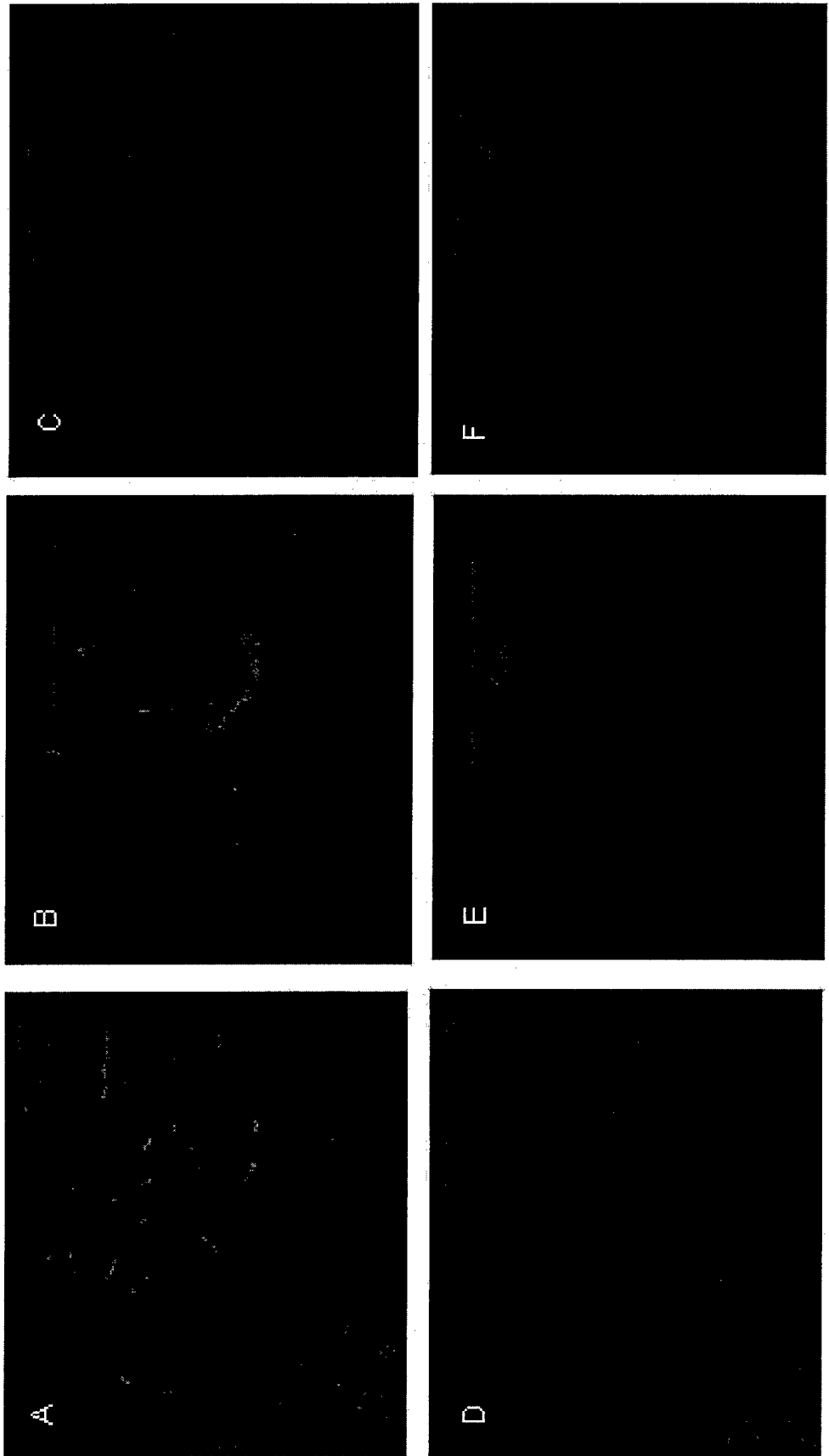

Figure 6

Perillyl alcohol inhibits breast cell migration without affecting cell adhesion

Johanna E. Wagner<sup>1</sup>, Janice L. Huff<sup>1</sup>, William L. Rust<sup>1</sup>, Karl Kingsley<sup>1</sup>, and George E. Plopper<sup>2,3</sup>

1 UNLV Cancer Institute and Department of Biological Sciences, University of Nevada, Las Vegas

2 Corresponding Author

3 Department of Biology, Rensselaer Polytechnic Institute, 110 8th Street, Troy NY 12180-3590

telephone (518) 276-8288, fax (518) 276-2162, email: ploppg@rpi.edu

Running title: Perillyl alcohol inhibits breast cell migration

## Abstract

The monoterpene d-limonene exhibits chemotherapeutic and chemopreventive potential in breast cancer patients. D-limonene and its related compounds, perillyl alcohol and perillyl aldehyde, were chosen as candidate drugs for application in a screen for non-toxic inhibitors of cell migration. Using the non-tumorigenic human breast cell line MCF-10A, we delineated toxicity as greatest for perillyl aldehyde, intermediate for perillyl alcohol and least for limonene. A non-cytotoxic concentration of 0.5 mM perillyl alcohol inhibited migration, while the same concentration of limonene failed to do so. Adhesion of the MCF-10A cell line and a human breast cancer cell line MDA-MB 435 to fibronectin was unaffected by 1.5 mM perillyl alcohol. 0.4 mM perillyl alcohol inhibited growth of MDA-MB 435 cells. All migration-inhibiting concentrations of perillyl alcohol for MDA-MB 435 cells proved toxic. These results suggest that sub-toxic doses of perillyl alcohol may have prophylactic potential in the treatment of breast cancer.

## Introduction

Cancer remains the second leading cause of death in the US (1). Tumor metastasis is the most deadly characteristic of cancer. Unlike primary tumors that can be surgically removed and treated with adjuvant chemotherapy and/or radiotherapy, metastases are difficult to treat and usually prove fatal (2).

The development of secondary tumors is a sequential process, commonly referred to as a "metastatic cascade," and failure to complete any one step prevents metastasis (2). During the metastatic cascade, primary tumor cells digest their surrounding extracellular matrix, migrate through interstitial spaces, and enter blood or lymphatic vessels where they are carried to distant organs. Once lodged in the target organs, these cells migrate into the interstitial spaces and continue growing to develop a secondary tumor, or metastasis (3). Thus, the migration and invasion of cancer cells provides many potential targets for therapeutic intervention.

Most anti-cancer drugs target the hyperproliferation of metastatic cells. While many of these drugs are efficacious in treating the beginning stages of cancer, none are curative for metastatic disease. Any delay in diagnosis also renders many of these drugs ineffective (4). In addition, antiproliferation compounds cause many adverse side effects, including nausea, vomiting, suppressed immune system and hair loss. It is, therefore, paramount that alternative therapies be developed that treat a greater scope of the disease and with less disturbance to the wellbeing of the patient.

Even though tumor cell migration is a hallmark feature of metastasis, since 1978 fewer than 100 compounds that have some capacity to inhibit tumor cell migration have been reported; however, thousands of compounds have yet to be tested. To address the need for a more comprehensive screen of possible anti-migration compounds, we recently developed an automated, high-throughput cytotoxicity/cell migration assay suitable for screening large numbers of samples (5).

During the development of our automated assay, we applied cell proliferation and migration assays to screen drugs, already known to have anti-cancer effects, for non-cytotoxic anti-migration properties. This report focuses on the effects of d-limonene and its derivatives. The chemotherapeutic and chemopreventative effects of d-limonene, a monoterpene found in the essential oils of citrus fruits, spices and herbs, have been studied extensively in spontaneous and chemically induced rodent tumors (6). Limonene serves as a precursor to other oxygenated monocyclic monoterpenes such as carveol, carvone, menthol, perillyl alcohol (POH) and perillyl aldehyde (7). Due to success in tumor regression in various rodent cancer models, clinical testing of the cancer chemotherapeutic activity of these compounds is in progress, including Phase I clinical trials of POH in breast cancer patients (8, 9).

D-limonene and its derivatives disrupt isoprenylation of members of the Ras family of G proteins by geranylgeranyl transferases in some instances (10), though the effects of this disruption on downstream cellular behaviors are only now being elucidated. Much of the focus thus far has been on inhibition of the

cell cycle machinery and induction of apoptosis (11). The effects of these compounds on migration, especially in breast cells, are unreported to date.

We report here that POH inhibits migration of both malignant and non-malignant human breast cells, and that migration inhibiting doses also prove cytotoxic in malignant cells. These results suggest that sub-toxic doses of POH may act as a preventative treatment for breast cancer.

## Materials and Methods

### *Materials*

MCF-10A and MDA-MB 435 cells were purchased from American Type Culture Collection. Fibronectin, epidermal growth factor, cholera toxin, and insulin were obtained from Calbiochem (La Jolla, CA). Hydrocortisone was purchased from Sigma-Aldrich Chemicals (St. Louis, MO). Horse serum was purchased from Irvine Scientific (Santa Ana, CA). Calcein-AM was purchased from Molecular Probes (Eugene, OR). Transwell migration plates were purchased from Costar (Cambridge, MA). Cell culture flasks and 96-well plates were purchased from VWR (Plainfield, NJ). Limonene, POH, and perillyl aldehyde were purchased from Aldrich Chemical Co. (Milwaukee, WI).

### *Cell Culture*

Cells were grown in 75 cm<sup>2</sup> Falcon tissue-culture flasks obtained from VWR (Plainfield, NJ). Cells were maintained at 37°C and 5% CO<sub>2</sub> in humidified chambers. MCF-10A cells were maintained in AM media—1:1 mixture of Ham's F-12 medium and Dulbecco's Modified Eagle's Medium High Glucose with 2 mM L-glutamine from Irvine Scientific (Santa Ana, CA) supplemented with the following: epidermal growth factor (20 ng/ml), cholera toxin (100 ng/ml), insulin (0.01 mg/ml), hydrocortisone (500 ng/ml) and 5% horse serum. MDA-MB 435 cells were maintained in RPMI Medium 1640 supplemented with 10% fetal bovine serum and 1% L-glutamine (29.2 mg/ml), penicillin G (10,000 units/ml) and streptomycin sulfate (10,000 µg/ml) from Irvine Scientific (Santa Ana, CA).

Cells were routinely passaged using trypsin/EDTA from Irvine Scientific (Santa Ana, CA).

#### *Proliferation Assay*

In 96-well plates  $3 \times 10^3$  cells were seeded in the appropriate serum-containing media and incubated for 2 hours at 37°C and 5% CO<sub>2</sub> in humidified chambers. Cells were then washed twice with PBS and grown in migration media (MCF-10A: DMEM and 0.1% BSA; MDA-MB 435: RPMI 1640 and 0.1% BSA) with indicated concentrations of limonene, perillyl alcohol or perillyl aldehyde for 24 hours. Cells were then washed twice with PBS, fixed in 3.7% formaldehyde for 15 minutes, stained with crystal violet and lysed with 1% sodium docecyl sulfate (SDS). Absorbance was read at 595 nm using a plate reader. Growth was measured as compared to a standard curve of cells grown in serum-containing media.

#### *Adhesion Assay*

Cell adhesion assays were performed as previously described in Costar 96-well Cell Culture Cluster plates (12). Tissue culture plates were coated with purified fibronectin (20 µg/mL in 50 mM carbonate buffer, pH 9.3) for 1 hour at room temperature. Wells were then washed with phosphate-buffered saline with 0.2 % Tween-20 (PBST), blocked with 5 % blotto (PBST with 5% skim milk) for one hour at 25° C. Wells were then washed twice with PBST prior to assay. Cells were seeded at a concentration of  $1.0 \times 10^6$  per well in cell culture plates with and without migration media (MCF-10A: DMEM and 0.1% BSA; MDA-MB 435:

RPML 1640 and 0.1% BSA) and perillyl alcohol and were allowed to attach for 30 minutes at 37°C in a humidified incubator containing 5% CO<sub>2</sub>. Unbound cells were dislodged by inverting, submerging and rocking the plate in PBS for 15 minutes. Cells were then fixed in 3.7% formaldehyde, stained with crystal violet and lysed with 1% SDS. Absorbance was measured at 595 nm in a plate reader.

### *Migration Assay*

Cell migration assays were performed as previously described in Costar transwell filter plates (7). Filters were coated with purified fibronectin at a concentration of 20 µg/ml in carbonate buffer (50 mM, pH 9.3) for 1 hour at room temperature. Filters were then aspirated and blocked in blotto (phosphate-buffered saline with 0.2% Tween-20 (PBST) and 5% skim milk) for 1 hour at room temperature. Next filters were washed in PBST prior to the assay. Thirty minutes prior to the starting the assay cells were pre-incubated at 37°C in migration media and indicated concentrations of POH. Cells were seeded at a concentration of  $1.2 \times 10^6$ /well on transwell filters with and without fibronectin in the presence or absence of soluble growth factors (serum-enriched media) and varying concentrations of POH and allowed to migrate for 18 hours at 37°C in 5% CO<sub>2</sub>. Thirty minutes before measuring migration, 5 µM of calcein-AM (Molecular Probes; Eugene, OR) was added to the migration wells. To quantify migration, cells were removed from the top of the filter with cotton swabs, washed in phosphate-buffered saline and fluorescence measured from the bottom of the filter with a plate reader for the incorporation of calcein-AM (8). Relative

fluorescence values for each experimental condition were expressed relative to control, untreated samples.

## Results and Discussion

D-limonene and its derivatives, POH and perillyl aldehyde, exhibited different degrees of toxicity in a 24-hour growth assay. D-limonene did not inhibit growth of MCF-10A cells at concentrations up to 1.0 mM (Fig. 1) or greater (not shown), while 0.5 mM perillyl aldehyde was completely toxic. In contrast, 0.5 mM POH was not cytotoxic, but concentrations of 0.75 mM and 1.0 mM were cytostatic and cytotoxic, respectively. The relatively high toxicity of perillyl aldehyde may be due to a proportionally high affinity for the enzymes farnesyl transferase (FT) and geranylgeranyl transferase (GGT) as has been shown for perillic acid methyl ester, a minor metabolite of limonene and POH (13). These enzymes are involved in post-translational modification of small G-proteins that are involved in a myriad of cell activities such as growth and migration. Inhibition of FT and GGT is suspected to be the basis of the anti-tumor effects of POH and limonene (13). However, in accord with our data, an equal concentration of limonene is not as effective in blocking cell proliferation as POH in other cell types (13, 14).

Migration assays established that a sub-toxic dose (0.5 mM) of POH inhibited haptotactic migration of MCF-10A cells on fibronectin (Fig. 2). Again, this difference is most likely attributable to POH having a greater potency than limonene in the inhibition of small G-protein isoprenylation (14). A probable mediator of this inhibited migration is the small G-protein RhoA, a member of the Rho family of small GTPases that is involved in a signaling pathway for cell migration (14, 15).

To test the effect of POH on adhesion to fibronectin, both non-cancerous (MCF-10A) cells and cancerous (MDA-MB 435) cells were exposed for 18 hours to increasing concentrations of POH prior to addition to a 30 minute adhesion assay. Both MCF-10A and MDA-MB 435 cell lines tolerated up to 1.5 mM POH with no statistically significant variation compared to 0 mM (Fig. 3). The treated cells exhibited rounding and a loss of cytoskeletal organization, but remained viable as determined by Trypan Blue exclusion and MTT reduction assays (Wagner et al., manuscript submitted). These results independently confirm the low toxicity of POH, and suggest that POH may inhibit migration by disrupting the cytoskeletal machinery required to exert the force necessary for lamellar extension. Integrin mediated adhesion, however, remained unaffected.

To directly assess the dose response to POH treatment, growth and migration assays were performed in parallel for both cell lines. In MCF-10A cells, 0.5 mM POH inhibited migration by over 75% and allowed cell growth, although at a lower rate (Fig. 4). In contrast, in MDA-MB 435 cells, this dose inhibited migration by over 85% but also reduced the cell number by nearly 20%. In fact, all concentrations of POH that inhibited migration were cytotoxic in this cell line (Fig. 5). This may be due to this cell line expressing a higher level of RhoA, as has been reported in other tumor cells as compared to nontumorigenic cells (16). An increased invasive phenotype is also characteristic of some liver and breast tumor cells in response to RhoA activation (16, 17). Additionally, POH treatment significantly increases apoptosis in pancreatic cancer cells relative to non-

malignant pancreas cells (18). Thus, POH may exert its effects through separate mechanisms in MCF-10 and MDA-MB 435 cells.

Given that a non-cytotoxic dose of POH can inhibit the migration of non-cancerous breast cells, and that this same dose can kill cancerous breast cells, this suggests the possibility that POH may be used as a prophylactic treatment for patients at risk of developing breast cancer. Such a strategy is currently being used with the anti-estrogen drug tamoxifen (19). Further studies are under way in our laboratory to explore the effects of low doses of POH on tumor progression.

#### **Acknowledgements**

We wish to thank J. Steven de Belle for assistance with statistical analysis. This work was supported by a career development grant (DAMD17-98-1-8325 to GEP) from the United States Army Breast Cancer Research Program.

## References

1. American Cancer Society. <http://www.cancer.org>
2. Alison, M. and C. Sarraf. 1997. *Understanding Cancer*. London: Cambridge University Press.
3. Liotta, L.A. 1986. Tumor invasion and metastasis—role of the extracellular matrix. *Cancer Research*. 46:1-7.
4. Kohn, E.C. and L.A. Liotta. 1995. Molecular insights into cancer invasion: Strategies for prevention and intervention. 55:1856-1862.
5. Rust, W.L., Huff, J.L. and G.E. Plopper. 2000. Screening assay for promigratory/antimigratory compounds. *Analytical Biochemistry*. 280:11-19.
6. Crowell, P.L. and M.N. Gould. 1994. Chemoprevention and therapy of cancer by d-limonene. *Critical Reviews in Oncogenesis*. 5:1-22.
7. Crowell, P.L. 1999. Prevention and therapy of cancer by dietary monoterpenes. *Journal of Nutrition*. 129:775S-778S.
8. Vigushin, D.M., Poon, G.K., Boddy, A., English, J., Halbert, G.W., Pagonis, C., Jarman, M. and R.C. Coombes. 1998. Phase I and pharmacokinetic study of d-limonene in patients with advanced cancer. *Cancer Chemotherapeutics and Pharmacology*. 42:111-117.
9. Phillipos, L.R., Malspeis, L. and J.G. Supko. 1995. Pharmacokinetics of active drug metabolites after oral administration of perillyl alcohol, an investigational antineoplastic agent, to the dog. *Drug Metabolism and Disposal*. 23:676-80.

10. Ren, Z., Elson, C.E. and M.N. Gould. 1997. Inhibition of type I and type II geranylgeranyl-protein transferases by monoterpene perillyl alcohol in NIH3T3 cells. *Biochemical Pharmacology*. 54:113-120.
11. Clark, S.S., Perman, S.M., Sahin M.B., Jenkins, G.J., and J.A. Elegbede. 2002. Antileukemia activity of perillyl alcohol (POH): uncoupling apoptosis from G0/G1 arrest suggests that the primary effect of POH on Bcr/Abl-transformed cells is to induce growth arrest. *Leukemia* 16(2):213-22.
12. Plopper, G.E., Domanico, S.Z., Cirulli, V., Kioses, W.B. and V. Quaranta. 1998. Migration of breast epithelial cells on integrins: differential role of integrins in normal and transformed cell types. *Breast Cancer Research*. 51:57-69.
13. Gelb, M., Tamanoi, F., Yokoyama, K., Ghomashchi, F., Esson, K. and M.N. Gould. 1995. The inhibition of protein prenyltransferases by oxygenated metabolites of limonene and perillyl alcohol.
14. Crowell, P.L., Ren, Z., Lin, S., Vedejs, E., and M.N. Gould. 1994. Structure-activity relationships among monoterpene inhibitors of protein isoprenylation and cell proliferation. *Biochemical Pharmacology*. 47:1405-1415.
15. Kjoller, L. and A. Hall. 1999. Signaling to Rho GTPases. *Experimental Cell Research*. 253:166-179.
16. Yoshioka, K., Nakamori, S. and K. Itoh. 1999. Overexpression of small GTP-binding protein RhoA promotes invasion of Tumor cells. *Cancer Research*. 59:2004-2010.

17. Bourguignon, L., Zhu, H., Shao, L., Zhu, D. and Y. Chen. 1999. Rho-kinase (ROK) promotes CD44<sub>v3,8-10</sub>-ankyrin interaction and tumor cell migration in metastatic breast cancer cells. *Cell Motility and the Cytoskeleton*. 43:269-287.
18. Stayrook, K.R., McKinzie, J.H., Burke, Y.D., Burke, Y.A. and P.L. Crowell. 1997. Induction of the apoptosis-promoting protein Bak by perillyl alcohol in pancreatic ductal adenocarcinoma relative to untransformed ductal epithelial cells. *Carcinogenesis*. 18:1655-1658.
19. Duffy S.W., and R.M. Nixon. 2002. Estimates of the likely prophylactic effect of tamoxifen in women with high risk BRCA1 and BRCA2 mutations. *British Journal of Cancer* 86(2):218-21.

## Figure Legends

Figure 1. Monoterpenes exhibit varying degrees of inhibition of breast cell growth. MCF-10A cells were plated at  $30 \times 10^3$  cells/well (dashed line) in serum-free minimal medium containing the indicated concentrations of monoterpenes, and counted 24 hours later. Bars represent mean  $\pm$  standard deviation (n=10). A student-Numan-Keuls test identified five groups (letters A-E;  $P \leq 0.05$ ) which were statistically different from one another (ANOVA F:[9, 98] = 121.63,  $P < 0.0001$ ).

Figure 2. Perillyl alcohol, but not D-limonene, inhibits breast cell migration. MCF-10A cells were allowed to migrate towards the bottom side of an 8  $\mu\text{m}$  pore filter coated with fibronectin for 18 hours in serum-free minimal medium containing the indicated concentrations of monoterpenes, or serum as a control. Migration towards non-fat dried milk (blotto) served as a negative control for random migration. Migration was quantitated by fluorescently labeling cells on the bottom of the filters and reading fluorescence with a plate reader. Results expressed as mean of Relative Fluorescence Units,  $\pm$  standard deviation (n=3). A student-Numan-Keuls test identified five groups (letters A-E;  $P \leq 0.05$ ) which were statistically different from one another (ANOVA F:[7, 23] = 231.76,  $P < 0.0001$ ).

Figure 3. Perillyl alcohol ( $\leq 1.5$  mM) does not interfere with breast cell adhesion to fibronectin. MCF-10A (A) or MDA-MB-435 cells (B) were plated on fibronectin for 30 minutes in the presence of the indicated concentrations of perillyl alcohol.

Adherent cells were quantitated by staining with crystal violet, solubilizing adherent dye, and measuring absorbance at 595 nm. Results expressed as mean  $\pm$  standard deviation (n=8). A student-Numan-Keuls test identified in (A) two partly overlapping groups (letters A, B) and two independent groups (letters C, D); and in (B), four independent groups (letters A-D),  $P \leq 0.05$ . All groups are statistically different from one another (panel A, ANOVA  $F:[6,55] = 144.88$ ,  $P < 0.0001$ ; panel B, ANOVA  $F:[6, 41] = 252.45$ ,  $P < 0.0001$ ).

Figure 4. 0.5 mM perillyl alcohol is a non-cytotoxic inhibitor of MCF-10A cell migration on fibronectin. Parallel measurements of cell migration (panel A) and cell growth (panel B) were performed as described for Figures 1 and 2 using MCF-10A cells exposed to the indicated concentrations of perillyl alcohol in serum-free minimal medium. For panel A, a student-Numan-Keuls test identified four groups, two of which overlapped (letters A-D;  $P \leq 0.05$ ). For panel B, a student-Numan-Keuls test identified six groups (letters A-F;  $P \leq 0.05$ ). All groups in each panel were statistically different from one another (Panel A, ANOVA  $F:[6, 20] = 33.80$ ,  $P < 0.0001$ ; Panel B, ANOVA  $F:[7, 79] = 253.58$ ,  $P < 0.0001$ ).

Figure 5. Perillyl alcohol is a cytotoxic inhibitor of MDA-MB-435 cell migration on fibronectin. Parallel measurements of cell migration (panel A) and cell growth (panel B) were performed as described for Figures 1 and 2 using MDA-MB-435 cells exposed to the indicated concentrations of perillyl alcohol in serum-free minimal medium. For panel A, a student-Numan-Keuls test identified four groups

(letters A-D;  $P \leq 0.05$ ). For panel B, a student-Numan-Keuls test identified five groups (letters A-E;  $P \leq 0.05$ ). All groups in each panel were statistically different from one another (Panel A, ANOVA  $F:[6, 23] = 33.80$ ,  $P < 0.0001$ ; Panel B, ANOVA  $F:[7, 80] = 56.08$ ,  $P < 0.0001$ ).

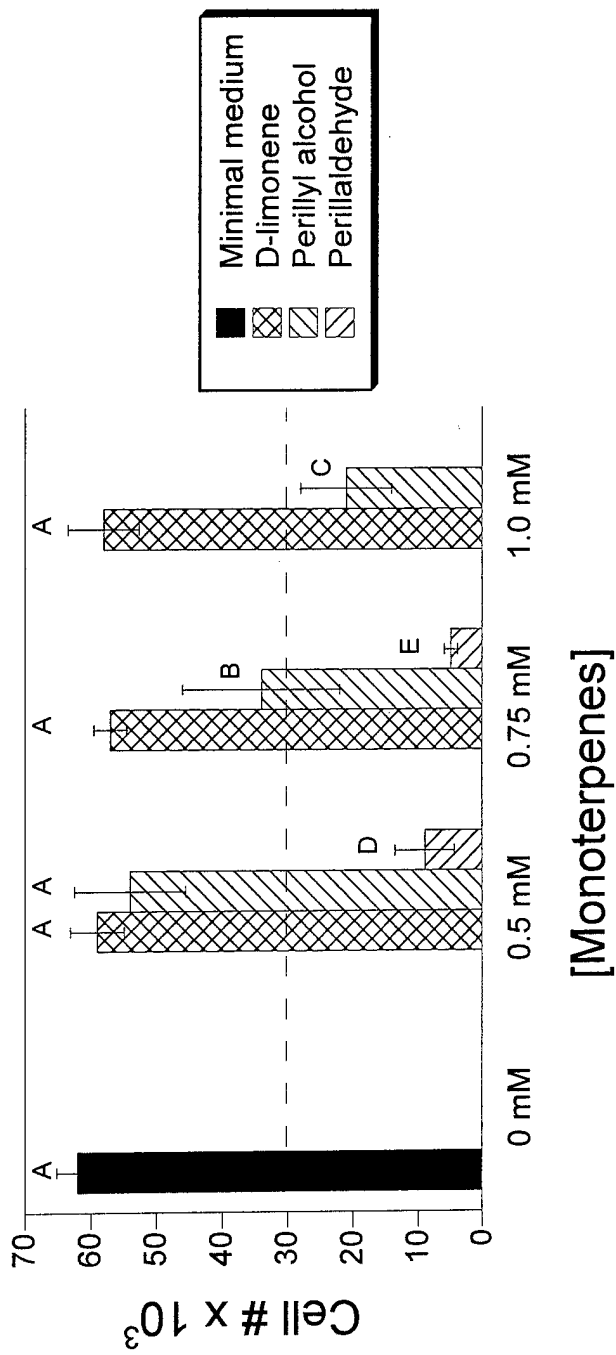

Figure 1

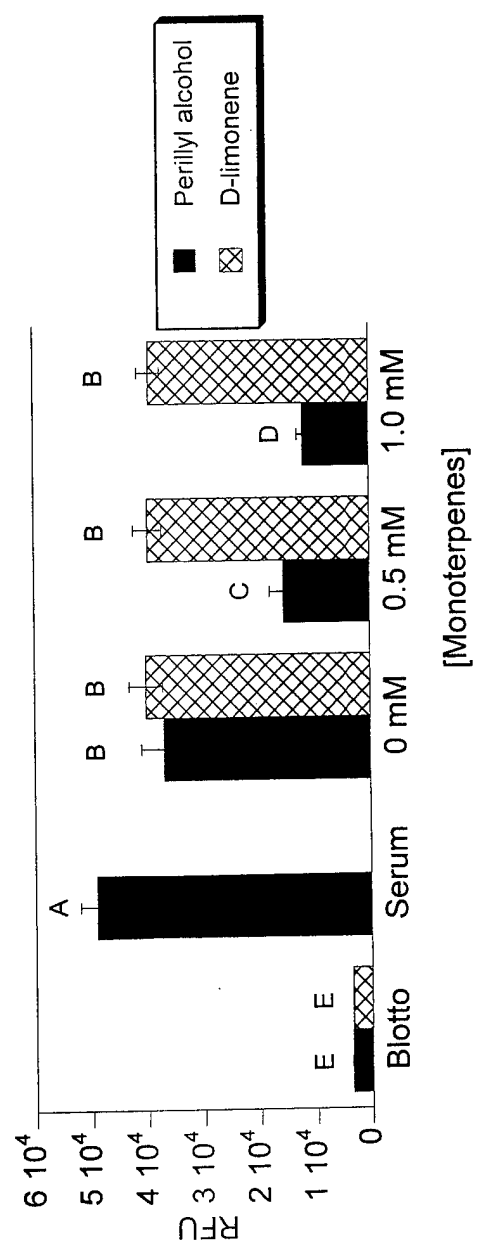
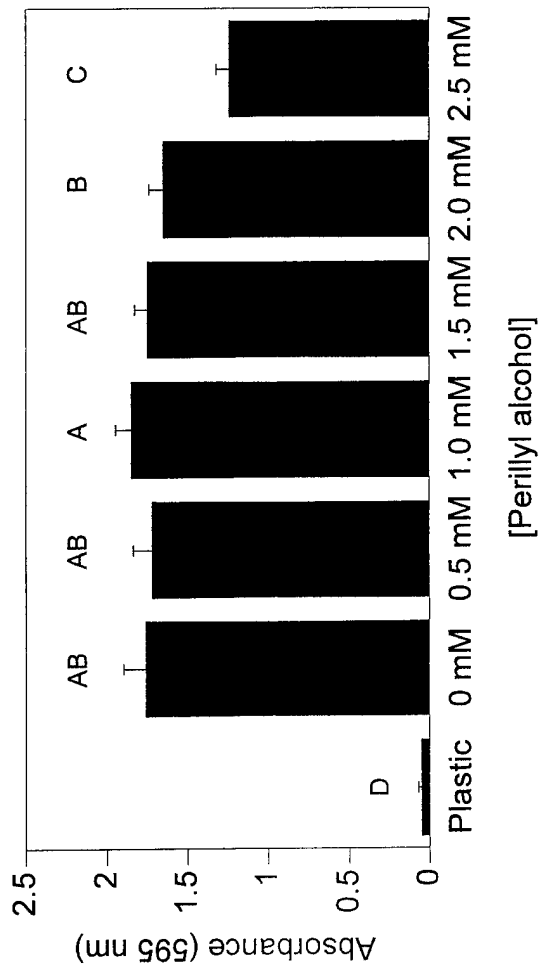
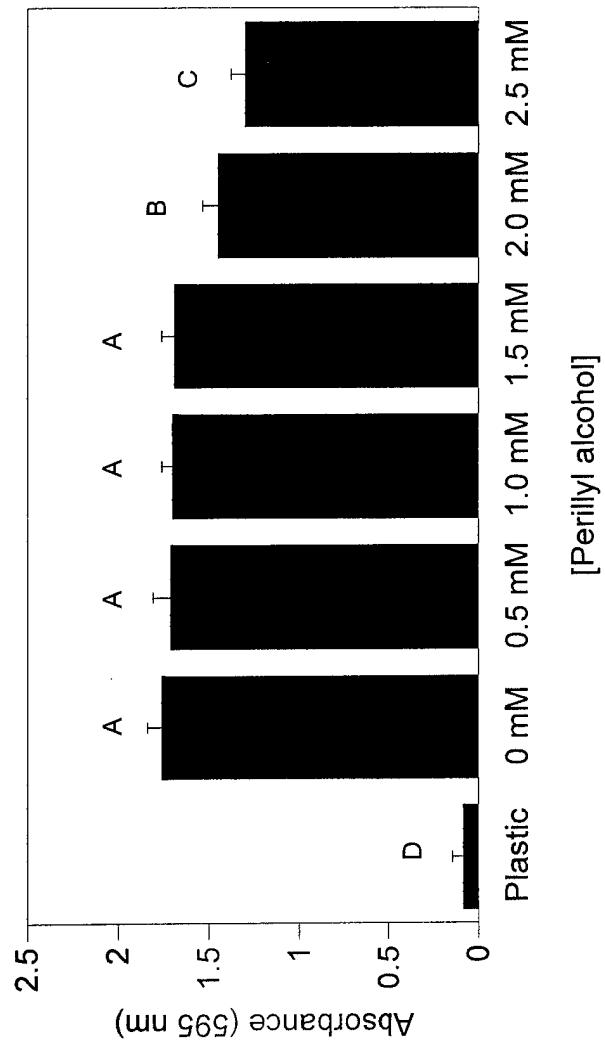

Figure 2



**Figure 3A**



**Figure 3B**

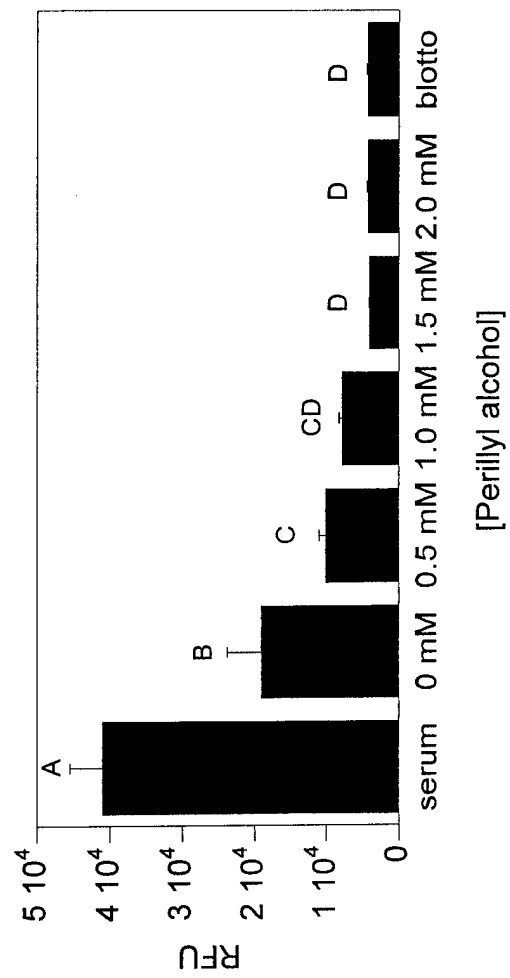

**Figure 4A**

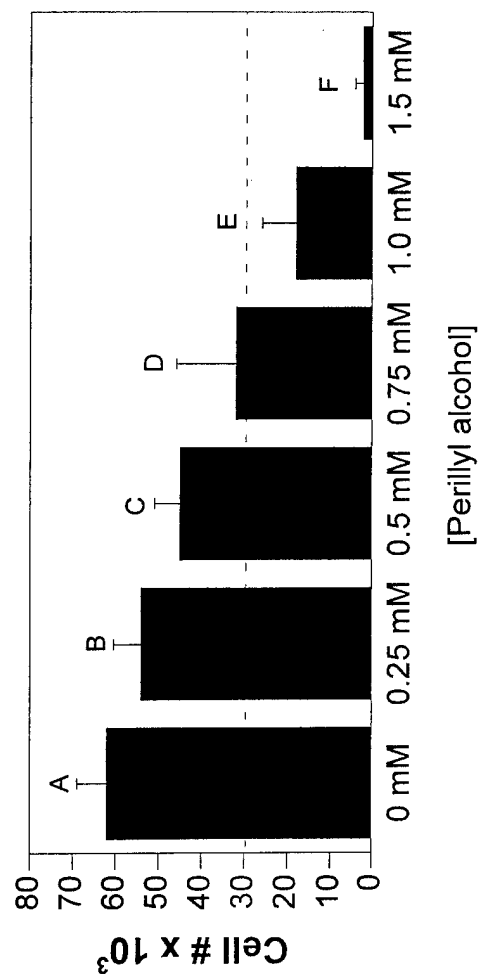

**Figure 4B**

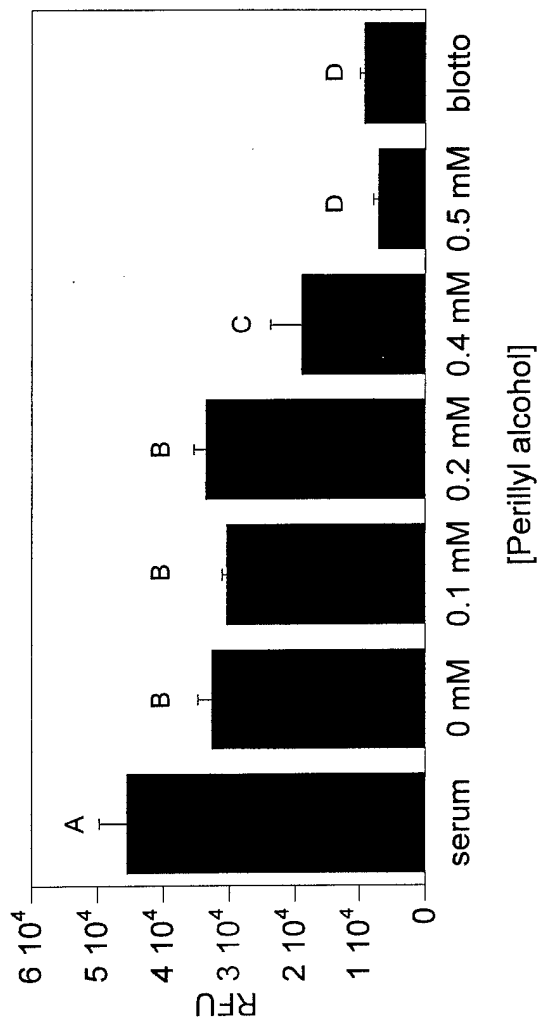

Figure 5A

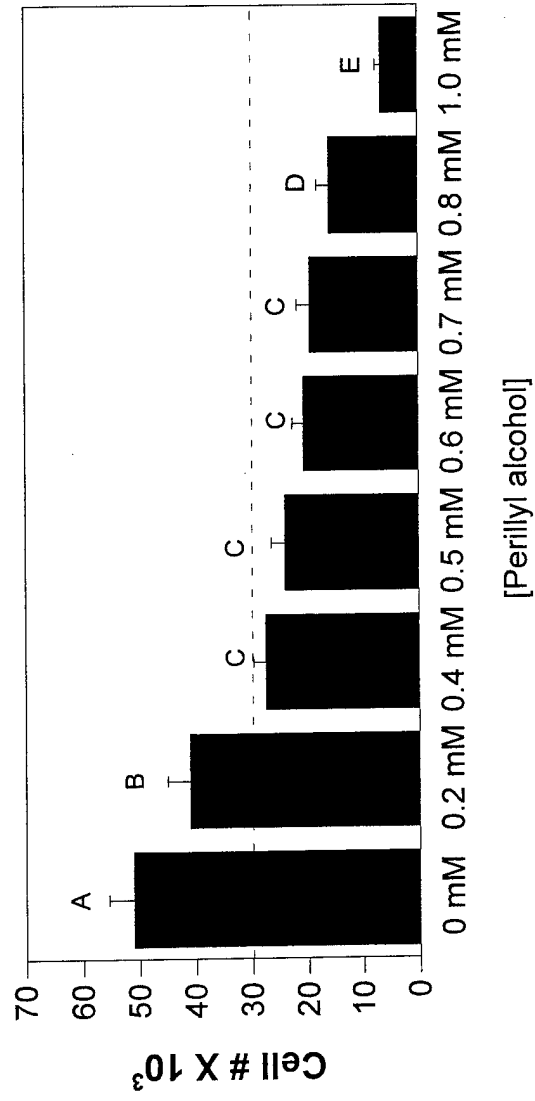

Figure 5B

**Title: The promise of integrins as effective targets for anti-cancer agents**

**William L. Rust<sup>1</sup>, Stephen W. Carper<sup>1</sup> and George E. Plopper<sup>2,3</sup>**

1 UNLV Cancer Institute and Chemistry Department, University of Nevada, Las Vegas

2 Corresponding Author

3 Department of Biology, Rensselaer Polytechnic Institute, 110 8th Street, Troy NY  
12180-3590

telephone (518) 276-8288, fax (518) 276-2162, email: ploppg@rpi.edu

Dr. Rust's current address is: Novartis Pharma AG, WSJ 386.631, CH-4002, Basel,  
Switzerland

Running Title: Integrin receptors: unrealized chemotherapeutic targets

## **Abstract**

This review will briefly describe integrin function, address why integrins are attractive targets for chemotherapeutic drug design, and discuss some ongoing studies aimed at inhibiting integrin activity. Integrins are cell surface heterodimeric receptors. They modulate many cellular processes including: growth, death (apoptosis), adhesion, migration, and invasion by activating several signaling pathways. Many potential chemotherapeutic agents target integrins directly (e.g., polypeptides, monoclonal antibodies, adenovirus vectors). These agents may be clinically useful in controlling the metastatic spread of cancer.

The primary therapy for most solid tumors is surgical resection, followed by a combination of radiation and chemotherapy. Most of the currently used chemotherapeutic agents target rapidly dividing cells. However, many solid tumors are not rapidly dividing and thus evade these agents. Often, tumors that resist or evade chemotherapy treatments continue to grow, and may spread to other, distant organs, resulting in the formation of secondary tumors (metastases). Once a cancer develops to this stage, patient prognosis is usually very poor. Novel chemotherapeutic agents need to be developed to help control the growth and spread of metastatic tumors. In this review, we discuss the potential value of integrins as chemotherapeutic targets. The function of integrins in cancer progression is addressed, followed by a discussion of current drug discovery efforts and clinical trials of compounds that specifically target integrin receptors.

The latest generation of chemotherapeutic agents is designed to target molecules required for survival by cancerous cells but not by normal cells. One very interesting group of molecules that are receiving attention is the integrin family of cell surface adhesion receptors. In the past 10 years, it has become clear that the integrins play an important role in virtually every stage of cancer progression. In addition, oncogenic transformation is often accompanied by changes in integrin expression and substrate preference. Although integrins are not oncoproteins, they modulate the processes of cell growth, death, migration, and invasion, which all impinge on the severity of clinical disease [1]. Several drugs in clinical trials function as integrin antagonists; all having shown promise as anti-angiogenic, anti-metastatic, and anti-proliferative compounds in mouse models [2].

#### *Integrin structure and function*

Integrins are a family of heterodimeric cell surface receptors. The known 18  $\alpha$  and 8  $\beta$  subunits combine to form at least 24  $\alpha\beta$  heterodimers (for recent reviews see references 2-4). Most cells express more than one type of integrin heterodimer. Integrin expression profiles are unique for distinct cell types, and change with developmental stage and physiological conditions within a cell type [5]. Most integrins mediate cell/substratum adhesion by binding to extracellular matrix (ECM) proteins, while a few mediate cell-cell adhesion via homotypic or heterotypic coupling with other cell surface receptors. This family of receptors can be classified into three subfamilies. The  $\beta 1$  integrins generally mediate interactions between cells and ECM. The  $\beta 2$  integrins are restricted to leukocytes and are typified by having other cell surface proteins as their ligands. The  $\beta 3$  integrins are almost exclusively expressed on platelets and megakaryocytes and act as important mediators of platelet adhesion [6]. Excepting the fibronectin receptor  $\alpha 5\beta 1$ , all integrins bind to more than one ligand. Each ECM molecule is also bound by more than one integrin. Although it is impossible to predict an integrin binding site based on sequence, an acidic residue is common to all known binding sites, and many contain the sequence RGD [2].

At sites of integrin activation and clustering, protein aggregates termed focal complexes and focal adhesions assemble on the intracellular surface. The types of proteins that form these complexes can be grouped as either structural, which form links to the actin cytoskeleton, or signaling, which include a variety of kinases and adapter molecules linking integrins to other kinases, members of the GTPase families, lipid

kinases and phospholipases, and ion channels [7,8]. The structural components are talin,  $\alpha$ -actinin, vinculin, and filamin. Of these, only  $\alpha$ -actinin binds directly to integrins, while the others are capable of binding each other and members of the signaling component [9,10]. These complexes are sites where the cell can generate tension with respect to its surroundings, allowing the cell to alter its shape and carry out complex processes such as migration and cell division [2].

#### *Integrin clusters are signaling complexes*

The signaling proteins found at focal complexes and focal adhesions associate with integrin cytoplasmic domains to form a nexus for stimulating intracellular signaling cascades. At these sites, signaling from outside to inside the cell occurs which contributes to the regulation of diverse cellular processes including entry into the cell cycle, programmed cell death (apoptosis), gene transcription, regulation of intracellular pH, differentiation, and migration. A summary of the known signaling pathways associated with integrin receptors is presented in Figure 1. Signaling through integrins from the inside to the outside of the cell regulates adhesive strength through affinity and avidity modulation, and helps in remodeling of the ECM during tissue development and tissue invasion. Exactly how this occurs is unknown, but phosphorylation of integrin subunits may be important in both processes [6].

The 125kDa kinase termed focal adhesion kinase (FAK) is the best characterized of the integrin-associated signaling proteins. FAK binds to integrin receptors and plays a central role in assembling complexes of signaling proteins at the cell surface. FAK has numerous tyrosine residues that, when phosphorylated, act as docking sites for the recruitment and activation of several SH2- and SH3-containing classes of signaling molecules. Talin and paxillin are implicated in the activation of FAK by stimulating its autophosphorylation on Y397. This opens a binding site for the oncoprotein Src. All three of these molecules are implicated in targeting FAK to the focal adhesion. Src also phosphorylates FAK on a number of residues, including Y925. The adaptor protein Grb2 binds to phosphorylated Y397, and through the action of the guanine nucleotide exchange factor SOS, connects activated receptor tyrosine kinases to Ras/ERK/MAP kinase cascades, [2,4,8,11]. Phosphatidyl Inositol 3-Kinase (PI-3K) also binds to Y397, and mediates cell proliferation, cell migration, and apoptosis through its downstream effector PKB/Akt [3,5]. The adaptor protein p130<sup>CAS</sup> is a substrate of the FAK/Src complex and is implicated in activating the ERK cascade as well as Jun N-terminal kinase (JNK). Both p130<sup>CAS</sup> and FAK are thought to use the ERK pathway to activate several transcription factors [4]. FAK is also implicated in controlling cell cycle progression and preventing apoptosis through a pathway involving protein kinase C, phospholipase A2, and p53 [4, 12].

Integrin regulated signaling proteins that can be activated independent of FAK include protein kinase C, integrin linked kinase, integrin associated protein, and the tetraspan (TMS4F) adapter proteins [2,11]. Integrin linked kinase appears to phosphorylate only integrin subunits, and may function as a bridge to FAK [2]. Although tetraspans can regulate cell motility, their mechanism of action is not understood.

#### *Integrins contribute to cancer progression*

Integrins act to promote the growth, and retard the death, of both normal and tumorigenic cells. In cooperation with growth factor receptors, they induce proliferation by specifically causing the transcription of the cyclins and cyclin dependent kinases (Cdks) required for transition past the G1 checkpoint, and by down-regulation of Cdk inhibitors [2,6,12]. The fact that most cells deprived of ECM interactions undergo apoptosis (programmed cell death), and that integrin ligation can rescue those cells, demonstrates that integrins are involved in stimulating apoptosis resistance mechanisms [2]. For instance, in some cell lines, integrins activate transcription of the Bcl-2 gene and increase the activity of MAPK, JNK, PI-3 kinase, and PKB/Akt, all of which are known to inhibit apoptosis [2,3,5,6]. Lastly, cell death by deprivation of engagement of ECM (anoikis) may be an important control mechanism in cancer since carcinoma cells that lose contact with the matrix would die rather than circulate and colonize distant sites [3,5]. Hence, changes in the integrin expression profile may dramatically influence the progression of malignant tumors.

Benign tumors are encapsulated by an organized lattice of basement membrane components. The progression to malignancy, and the clinical diagnosis of malignant disease, is essentially determined by the capability of tumor cells to dissociate, degrade the lattice, and metastasize to other locations within the body. This process, termed the metastatic cascade, begins with the detachment of single tumor cells and active infiltration by those cells into the surrounding stroma where entry into the vasculature and lymphatic system is possible. Dissociation of individual cells from a tumor mass is regulated by the E-cadherin family of receptors. These are shown to be suppressors of epithelial tumor metastasis. Recently, activation of integrin  $\alpha3\beta1$  was shown to down-regulate E-cadherin mediated adhesion, causing loss of cell-cell adhesion, junctional communication, and enhancing invasiveness of malignant tumor cells [13]. For invasion by dissociated cells to occur, the ECM that surrounds the neoplastic tissue must be degraded to allow the escape of invasive cells. Integrins participate in the ECM degradation by stimulating the secretion of ECM-degrading proteases such as matrix metalloproteases, and enhancing invasion through a signaling cascade involving Ras [2,3].

#### *Integrins as therapeutic markers*

The large number of investigations into the effectiveness of integrins as indicators of disease and as an aid to non-invasive cancer imaging underlines the potential usefulness of these receptors in the clinic. Several recent studies show that both upregulation and downregulation of integrin expression can be effective markers of incidence of disease and patient prognosis. A comparison of normal and neoplastic human prostate tissues showed a downregulation of a specific variant of the  $\beta1$  integrin subunit [14], and strong evidence shows that reduced expression of  $\alpha6$  and  $\beta4$  may contribute to the higher tumorigenicity of androgen independent prostate tumor cells [15]. In a study of metastatic melanoma, longer disease free survival and overall survival correlated with  $\beta1$  expression [16], while neuroblastoma aggressiveness was correlated with expression of integrin  $\alpha v\beta3$  and  $\alpha v\beta5$  by the microvascular endothelium [17]. Studies of acute lymphoblastic leukemia show that  $\beta2$  expression was significantly associated with splenomegaly [18], and expression of  $\alpha5\beta1$  was associated with positive response to chemotherapy in patients with rectal cancer [19]. Finally, node negative non-

small cell lung cancer patients whose tumors over-express integrin  $\alpha 5$  had a lower survival rate than those whose did not [20].

These clinical correlations of patient biopsies to integrin expression are recapitulated to some degree in rodent and in vitro analyses. For example, a study of rat hepatocarcinogenesis showed that integrins  $\alpha 1$  and  $\alpha 5$  were upregulated in metastases of the lung and diaphragm, while integrins  $\alpha 1$ ,  $\alpha 2$ ,  $\alpha 3$ , and  $\alpha 5$  were decreased in the primary carcinoma and preneoplastic nodules [21]. Among pancreatic cancer cell lines, those that showed a higher potential to metastasize in a mouse model had enhanced expression of  $\alpha \nu \beta 5$  while those that did not metastasize had enhanced expression of  $\alpha 3$  [22]. The expression of  $\beta 4$  was inversely correlated with dissemination of ten human gastric cancer cells lines in SCID mice [23], and two of three human epithelial ovarian cancer cell lines could be identified by high expression of  $\alpha \nu \beta 6$  integrin, which was correlated with integrin linked signaling and protease secretion [24]. The development of endometrial cancers has been linked to the loss of progesterone receptors. It was found that re-expressing an isoform of that receptor inhibited the expression of integrin  $\alpha 3$ ,  $\beta 1$ , and  $\beta 3$  subunits and concomitant inhibition of cell invasion into matrigel [25].

In addition to the cases mentioned above, integrin expression can also be specific to levels of tumor resistance to common anti-cancer chemotherapies. Gastrointestinal tumor cells selected for resistance to 5-fluorouracil showed marked under-expression of the integrin  $\alpha 3$  [26] while human ovarian cancer cell lines resistant to the fenretinide were associated with reduced expression of  $\beta 1$  integrin [27]. A nasal carcinoma cell line resistant to melphalan showed increased expression of  $\alpha 2$ ,  $\alpha 5$ ,  $\alpha 6$ , and  $\beta 4$ , decreased expression of  $\alpha 4$  and exhibited enhanced invasion in vitro [28]. Glioma cell lines resistant to vincristine, doxorubicin, and etoposide, showed enhanced expression of integrins  $\alpha 2$ ,  $\alpha 3$ ,  $\alpha 5$ , and  $\beta 1$  [29].

If the integrin receptors expressed by a particular tumor are reproducibly correlated with patient prognosis, that knowledge can be used by the clinician to choose the appropriate therapeutic regimen. Non invasive imaging based on integrin expression is potentially useful not only to identify particular types of tumors but to assess their responsiveness to particular drugs or drug-targeting methods. In two recent studies, a glycopeptide containing the integrin binding domain RGD was found in tumor mouse models to be suitable for tumor visualization and determination of integrin status [30], and a similar peptide specifically bound to  $\alpha \nu \beta 3$  expressing tumors in vivo [31].

#### *Integrins as targets for drug delivery and gene therapy*

Achieving tissue-specific drug delivery is the primary challenge faced by researchers in the fields of gene therapy, targeted drug delivery, and immune mediated tumor destruction. Integrin expression can both provide solutions to and exacerbate the difficulty of this problem. An excellent example is the use of recombinant adenoviruses that interact with cell surface integrins. Some adenoviruses are successfully internalized into host cells by forming complexes with the host proteins CAR (Coxsackie B virus and Ad Receptor) and integrins  $\alpha \nu \beta 3$  and  $\alpha \nu \beta 5$  [36]. The semi-specific expression of these proteins makes targeting difficult. In some cases replacing the binding capacities of the viral capsid may prove effective while in others it may be effective to enhance the integrin binding capacities. Using the former strategy, an adenoviral vector targeted

solely to the human epidermal growth factor receptor showed improved targeting to tumors of the brain [37]. But an adenovirus vector targeted to CAR, epidermal growth factor receptor, and  $\alpha v$  integrins via the RGD peptide showed enhanced gene transfer efficiency to pancreatic carcinoma and glioma cells [38, 39]. In a study of adenoviral gene transfer efficiency in ovarian cancer cells, poorly infected cell lines showed no expression of  $\alpha v\beta 3$  integrins, and re-expression of these receptors increased adenoviral infection [40]. In order to target cells not expressing CAR or  $\alpha v$  integrins, an antibody specific for the adenoviral vector was fused with recombinant growth factors to serve as a bridge for targeted infection [41]. Recently, integrin receptors expressed in large numbers on most ovarian cancers ( $\alpha v\beta 3$  and  $\alpha v\beta 5$ ) were used as binding targets for adenovirus vectors containing the herpes simplex virus thymidine kinase gene for molecular chemotherapy [42]. These vectors were very effective against purified primary ovarian cancer cells and may be a useful agent for treating ovarian cancer in clinical trials.

Another example is the targeting and activation of lymphoid cells to tumor sites, which require binding through integrin receptors. This binding can be modulated by secreted chemokines [32]. In a unique mixture of strategies, infection of mice with adenovirus carrying IL-12 gene and targeted to  $\alpha v\beta 3$  integrin expressed on liver metastases led to enhanced recruitment of adoptively transferred cytolytic T lymphocytes [33]. In another case, a human transitional cell carcinoma cell line transfected to over-express IL-6 showed concomitant increases in  $\alpha 5$  and  $\beta 1$  expression, which increased the adherence of tumor destroying cells of bacillus Calmette-Guerin therapy [34]. A chimeric cell adhesion molecule containing the  $\alpha v\beta 3$  disintegrin kistrin and CD31/PECAM-1 served as a bridge to home adoptively transferred lymphoid cells to angiogenic endothelial cells and caused the accumulation of lymphoid cells to angiogenic tumors in lewis lung and melanoma mice models [35].

Finally, in an effort to target a recombinant virus that does not use integrins in the process of internalization, a capsid of the feline panleukopenia virus was modified to express the RGD motif to bind  $\alpha v$  integrins. This successfully contributed to directing infection of those particles to a human rhabdomyosarcoma cell line [43].

#### *Non-viral strategies for disrupting integrins*

Non-viral and non-lymphoid strategies for integrin-specific tumor targeting focus on integrin-specific antibodies, soluble integrin ligands, or vectors that encode cyclic glycopeptides that contain the integrin binding RGD sequence. A vector with the RGD motif was found to preferentially colocalize to tumor tissues over the lung, kidney and spleen in nude mice (18). In lysosomal vectors that resemble retroviral envelopes but are not-toxic, this motif was shown to aid transduction of human melanoma cells (19). The anti-microbial peptide tachyplesin coupled to this motif was effective in inhibiting the growth of tumors in a mouse model and inducing apoptosis of prostate cancer cells in vitro (34). Alone, an RGD containing peptide caused anoikis of glioblastoma cell lines and prolonged the survival of SCID mice with intracranial tumors. (27). And finally, RGD containing peptides have shown promise as drug delivery agents for radiotherapy. This is thought to be effective because irradiated tumor blood vessels are found to have activated  $\alpha IIb\beta 3$  integrins. At least one of these peptides, biapcitide, is currently in clinical trials (36).

Disintegrin is the name given to soluble integrin ligands (originally isolated from snake venom) that disrupt cell-matrix interactions [28]. One disintegrin, contortrostatin, disrupts cytoskeletal structure and hence inhibits cell motility, raising the possibility that these compounds may be useful for therapeutic intervention for cancer invasion and metastasis [29]. Abciximab is a mouse-human chimeric monoclonal Fab fragment approved for adjunct therapy for the prevention of cardiac coronary intervention. Abciximab binds to the integrin  $\alpha_{IIb}\beta_3$  (GPIIb/IIIa) receptor on platelets which is the major adhesion receptor involved in aggregation. It also binds two other integrin receptors: the  $\alpha_v\beta_3$  receptor (present in high density on activated endothelial and smooth muscle cells) and  $\alpha_M\beta_2$  integrin (present on activated leukocytes) [30]. It is reasonable to assume that Abciximab may have anti-metastatic properties in cases of tumors that express the above integrin receptors.

The specificity of these inhibitors varies for different types of integrins. Therefore, to develop and then effectively utilize an anti-integrin therapy, the type of integrin and/or effectiveness of each agent or combination of agents must be measured. We have developed a fluorescence-based automated assay for identifying antimigratory compounds with the ability to discern cytotoxic from noncytotoxic modes of action that can achieve this goal [52]. The assay utilizes a chambered well that can be used to simultaneously measure migration and viability of cells following treatment with inhibitors. This enables us to assay the effects of compounds that disrupt integrins directly, or that interfere with downstream signaling events following integrin ligation. For example, with this assay we have been able to show that carboxyamidotriazole, a calcium channel blocker, inhibits chemotactic and haptotactic migration of breast cancer cells more effectively than tamoxifen (an antiestrogen). This assay should increase the ability to rapidly screen chemical libraries for even more compounds that inhibit integrin function.

These are but a few examples of agents currently in development to target integrins as anticancer therapies. These agents hold the promise of being effective, selective, and highly tolerable in adjuvant therapies.

#### Acknowledgements

This work was supported by a career development grant (DAMD17-98-1-8325 to GEP) and a predoctoral grant (DAMD17-00-1-0363 to WLR) from the United States Army Breast Cancer Research Program.

#### References

1. Engers R., Gabbert, H.E. 2000. Mechanisms of Tumor Metastasis: Cell Biological Aspects and Clinical Implications. *Journal of Cancer Research and Clinical Oncology* 126, pp682-692.
2. Berman, A.E., Kozlova, N.I. 2000. Integrins: Structure and Functions. *Membrane Cell Biology* 13 (2), pp207-244.

3. Parise, L.V., Jung, W. L., Juliano, R.L. 2000. New Aspects of Integrin Signaling in Cancer. *Cancer Biology* 10, pp407-414.
4. Guan, J-L., Zhao, J-H. 2000. Role of Focal Adhesion Kinase in Signaling by the Extracellular Matrix. *Progress in Molecular and Subcellular Biology* 25, pp37-53.
5. Mercurio, A.M., Bachelder, R.E., Rabinovitz, I., O'Conner, K.L., Tani, T., Shaw, L.M. 2001. The Metastatic Odyssey: the Integrin Connection. *Surgical Oncology Clinics of North America* 10 (2), pp313-328.
6. Coppolino, M.G., Dedhar, S. 2000. Bi-directional Signal Transduction by Integrin Receptors. *The International Journal of Biochemistry and Cell Biology* 32, pp171-188.
7. Ivaska, J., Heino, J. 2000. Adhesion Receptors and Cell Invasion: Mechanisms of Integrin-Guided Degradation of Extracellular Matrix. *Cell and Molecular Life Sciences* 57, pp16-24.
8. Parsons, J.T., Martin, K.H., Slack, J.K., Taylor, J.M., Weed., S.A. 2000. Focal Adhesion Kinase: A Regulator of Focal Adhesion Dynamics and Cell Movement. *Oncogene* 19, pp5606-5613.
9. Turner, C.E. 2000. Paxillin and Focal Adhesion Signaling. *Nature Cell Biology* 2, ppE231-E236.
10. Calderwood, D.A., Shattil S.J., Ginsberg, M.H. 2000. Integrins and Actin Filaments: Reciprocal Regulation of Cell Adhesion and Signaling. *The Journal of Biological Chemistry* 275 (30), pp22607-22610.
11. Hulleman, E., Boonstra, J. 2001. Regulation of G1 Phase Progression by Growth Factors and the Extracellular Matrix. *Cell and Molecular Life Sciences* 58, pp80-93.
12. Assoian, R.K., Schwartz, M.A. 2001. Coordinate Signaling by Integrins and Receptor Tyrosine Kinases in the Regulation of G1 Phase Cell Cycle Progression. *Current Opinion in Genetics and Development* 11, pp48-53.
13. Kawano, K., Kantak, S. S., Murai, M., Yao, C-C., Kramer, R.H. 2001. Integrin  $\alpha\beta 1$  engagement disrupts intercellular adhesion. *Experimental Cell Research* 262, pp180-196.
14. Perlino, E., Lovecchio, M., Vacca, R.A., Fornaro, M., Moro, L., ditonno, P., Battaglia, M., Selvaggi, F.P., Mastropasqua, M.G., Bufo, P., Languino, L.R. 2000. Regulation of mRNA and protein levels of beta1 integrin variants in human prostate carcinoma. *American Journal of Pathology* 157(5), pp1727-34.
15. Bonaccorsi, L., Carloni, V., Muratori, M., Salvadori, A., Giannini, A., Carini, M., Serio, M., Forti, G., Baldi, E. 2000. Androgen receptor expression in prostate carcinoma

cells suppresses alpha6beta4 integrin-mediated invasive phenotype. *Endocrinology* 141(9), pp3172-82.

16. Vihinen, P., Nikkola, J., Vlaykova, T., Hahka-Kemppinen, M., Talve, L., Heino, J., Pyrhonen, S. 2000. Prognostic value of beta1 integrin expression in metastatic melanoma. *Melanoma Research* 10(3), pp243-51.

17. Erdreich-Epstein, A., Shimada, H., Groshen, s., Liu, M., Metelitsa, L.S., Kim, K.S., Stins, M.F., Seeger, R.C., Durden, D.L. 2000 Integrins alphavbeta3 and alphavbeta5 are expressed by endothelium of high-risk neuroblastoma and their inhibition is associated with increased endogenous ceramide. *Cancer Research* 60(3), pp712-21.

18. Mengarelli, A., Zarcone, D., Caruso, R., Tenca, C., Rana, I., Pinto, R.M., Grossi, C.E., De Rossi, G. 2001. Adhesion molecule expression, clinical features, and therapy outcome in childhood acute lymphoblastic leukemia. *Leukemia & Lymphoma* 40(5-6), pp625-30.

19. Jayne, D.G., Heath, R.M., Dewhurst, O., Scott, N., Guillou, P.J. 2002. Extracellular matrix proteins and chemoradiotherapy:  $\alpha 5\beta 1$  integrin as a predictive marker in rectal cancer. *European Journal of Surgical Oncology* 28, pp30-36.

20. Adachi, M., Taki, T., Higashiyama, M., Kohno, N., Inufusa, H., Miyake, M. 2000. Significance of integrin alpha5 gene expression as a prognostic factor in node-negative non-small cell lung cancer. *Clinical Cancer Research* 6(1), pp96-101.

21. Yuan, S.T., Hu, X.Q., Lu, J.P., KeiKi, H., Zhai, W.R. Zhang, Y.E. 2000. Changes of integrin expression in rat hepatocarcinogenesis induced by 3'-Me-DAB. *World Journal of Gastroenterology* 6(2), pp231-3.

22. Nishimori, H., Yasoshima, T., Hata, F., Denno, R., Yanai, Y., Nomura, H., Tanaka, H., Kamiguchi, K., Sato, N., Hirata, K. 2002. A novel nude mouse model of liver metastasis and peritoneal dissemination from the same human pancreatic cancer line. *Pancreas*, 24(3), pp242-50.

23. Ishii, Y., Ochiai, A., Yamada, T., Akimoto, S., Yanagihara, K., Kitajima, M., Hirohashi, S. 2000. Integrin  $\alpha 6\beta 4$  as a suppressor and a predictive marker for peritoneal dissemination in human gastric cancer. *Gastroenterology* 118, pp497-506.

24. Ahmed, N., Pansino, F., Baker, M., Rice, G., Quinn, M. 2002. Association between alphavbeta6 integrin expression, elevated p42/44 kDa MAPK, and plasminogen-dependent matrix degradation in ovarian cancer. *Journal of Cellular Biochemistry* 84(4), pp 675-86.

25. Zhang, G.J., Crist, S.A., MCKerrow, A.K., Xu, Y., Ladehoff, D.C., See, W.A. 2000. Autocrine IL-6 production by human transitional carcinoma cells upregulates expression of the  $\alpha 5\beta 1$  fibronectin receptor. *Journal of Urology* 163(5), pp1553-9.

26. Takechi, T., Koizumi, K., Tsujimoto, H., Fukushima, M. 2001. Screening of differentially expressed genes in 5-fluorouracil-resistant human gastrointestinal tumor cells. *Japanese Journal of Cancer Research* 92(6), pp696-703
27. Appierto, V., Cavadini, E., Pergolizzi, R., Cleris, L., Lotan, R., Canevari, S., Formelli, F. 2001. Decrease in drug accumulation and in tumour aggressiveness marker expression in a fenretinide-induced resistant ovarian tumour cell line. 2001. *British Journal of Cancer* 84(11), pp1528-34.
28. Liang, Y., Meleady, P., Cleary, I., McDonnell, S., Connolly, L., Clynes, M. 2001. Selection with melphalan or paclitaxel (Taxol) yields variants with different patterns of multidrug resistance, integrin expression and in vitro invasiveness. *European Journal of Cancer* 37(8), pp1041-52.
29. Hikawa, T., Mori, T., Abe, T., Hori, S. 2000. The ability in adhesion and invasion of drug-resistant human glioma cells. *Journal of Experimental and Clinical Cancer Research* 19(3), pp357-62.
30. Haubner, R., Wester, H.-J., Weber, W.A., Mang, C., Ziegler, S.I., Goodman, S.L., Senekowitsch-Schmidtke, R., Kessler, H., Schwaiger, M. 2001. Noninvasive imaging of  $\alpha$ v $\beta$ 3 integrin expression using 18F-labeled RGD-containing glycopeptide and positron emission tomography. *Cancer Research* 61, pp1781-5.
31. Haubner, R., Wester, H.J., Burkhart, F., Senekowitsch-Schmidtke, R., Weber, W., Goodman, S.L., Kessler, H. Schwaiger, M. 2001. Glycosylated RGD-containing peptides: tracer for tumor targeting and angiogenesis imaging with improved biokinetics. *Journal of Nuclear Medicine* 42(2), pp326-36.
32. Fujiwara, H., Hamaoka, T. 2001. Coordination of chemokine and adhesion systems in intratumoral T cell migration responsible for the induction of tumor regression. *International Immunopharmacology* 1(4), pp613-23.
33. Mazzolini, G., Narvaiza, I., Bustos, M., Duarte, M., Tirapu, I., Bilbao, R., Qian, C., Prieto, J., Melero, I. 2001.  $\alpha$ v $\beta$ 3 integrin-mediated adenoviral transfer of interleukin-12 at the periphery of hepatic colon cancer metastases induces VCAM-1 expression and T-cell recruitment. *Molecular Therapy* 3(5 pt 1), pp665-72.
34. Zhang, G.J., Crist, S.A., MCKerrow, A.K., Xu, Y., Ladehoff, D.C., See, W.A. 2000. Autocrine IL-6 production by human transitional carcinoma cells upregulates expression of the  $\alpha$ 5 $\beta$ 1 fibronectin receptor. *Journal of Urology* 163(5), pp1553-9.
35. Wiedle, G., Johnson-Leger, C., Imhof, B.A. 1999. A chimeric cell adhesion molecule mediates homing of lymphocytes to vascularized tumors. *Cancer Research* 59(20), pp5255-63.

36. Davison, E., Kirby, I., Whitehouse, J., Hart, I., Marshall, J.F., Santis, G. 2001. Adenovirus type 5 uptake by lung adenocarcinoma cells in culture correlates with Ad5 fibre binding is mediated by alpha(v)beta1 integrin and can be modulated by changes in beta1 integrin function. *Journal of Gene Medicine* 3(6), pp550-9.
37. Van Beusechem V.W., Grill, J., Mastenbroek, D.C., Wickham, T.J., Roelvink, P.W., Haisma, H.J., Lamfers, M.L., Dirven, C.M., Pinedo, H.M., Gerritsen, W.R. 2002. Efficient and selective gene transfer into primary human brain tumors by using single-chain antibody-targeted adenoviral vectors with native tropism abolished. *Journal of Virology* 76(6), pp2753-62.
38. Wesseling, J.G., Bosma, P.J., Krasnykh, V., Kashentseva, E.A., Blackwell, J.L., Reynolds, P.N., Li, H., Parameshwar, M., Vickers, S.M., Jaffee, E.M., Huibregtse, K., Curiel, D.T., Dmitriev, I. 2001. Improved gene transfer efficiency to primary and established human pancreatic carcinoma target cells via epidermal growth factor receptors and integrin targeted adenoviral vectors. *Gene Therapy* 8(13), pp969-76.
39. Grill, J., Van Beusechem, V.W., Van Der Valk, P., Dirven, M.F., Leonhart, A., Pherai, D.S., Haisma, H.J., Pinedo, H.M., Curiel, D.T., Gerritsen, W.R. 2001. Combined targeting of adenoviruses to integrins and epidermal growth factor receptors increases gene transfer efficiency into primary glioma cells and spheroids. *Clinical Cancer Research* 7, pp641-50.
40. Bruning, A., Kohler, T., Quist, S., Wang-Gohrke, S., Moebus, V.J., Kreienberg, R., Runnebaum, I.B. 2001. Adenoviral transduction efficiency of ovarian cancer cells can be limited by loss of integrin beta3 subunit expression and increased by reconstitution of integrin alphavbeta3. *Human Gene Therapy* 12(4), pp391-9.
41. Li, E., Brown, S.L., Von Seggern, D.J., Brown, G.B., Nemerow, G.R. Signaling antibodies complexed with adenovirus circumvent CAR and integrin interactions and improve gene delivery. *Gene Therapy* 7(18), pp1593-9.
42. Hemminki, A., Belousova, N., Zinn, K.R., Liu, B., Wang, M., Chanduri, T.R., Rogers, B.E., Buchsbaum, D.J., Siegal, G.P., Barnes, M.N., Gomez-Navarro, J., Curiel, D.T., and Alvarez, R.D. 2001. An adenovirus with enhanced infectivity mediates molecular chemotherapy of ovarian cancer cells and allows imaging of gene expression. *Molecular Therapy* 4(3), pp223-231.
43. Maxwell, I.H., Chapman, J.T., Scherrer, L.C. Spitzer, A.L., Leptihn, S., Maxwell, F., Corsini, J.A. 2001. Expansion of tropism of a feline parvovirus to target a human tumor cell line by display of an alpha(v) integrin binding peptide on the capsid. *Gene Therapy* 8(4), pp324-31.
44. Aoki, Y., Hosaka, S., Kawa, S., Kiyosawa, K. 2001. Potential tumor-targeting peptide vector of histidylated oligolysine conjugated to a tumor-homing RGD motif. *Cancer Gene Therapy* 8(10), pp783-7.

45. Nahde, T., Muller, K., Fahr, A., Muller, R., Brusselbach, S. 2001. Combined transductional and transcriptional targeting of melanoma cells by artificial virus-like particles. *Journal of Gene Medicine* 3(4), pp353-61.
46. Chen, Y., Xu, X., Hong, S., Chen, J., Liu, N., Underhill, C.B., Creswell, K., Zhang, L. 2001. RGD-Tachyplesin inhibits tumor growth. *Cancer Research* 61, pp2434-8.
47. Chatterjee, S., Matsumura, A., Schradermeier, J. Gillespie, G.Y. 2000. Human malignant glioma therapy using anti-alpha(v)beta3 integrin agents. *Journal of Neurooncology* 46(2), pp135-44.
48. Hallahan, D.E., Qu, S., Geng, L., Cmelak, A., Chakravarthy, A., Martin, W., Scarfone, C., Giorgio, T. 2001. Radiation-mediated control of drug delivery. *American Journal of Clinical Oncology* 24(5), pp473-80.
49. Gould RJ, Polokoff MA, Friedman PA, Huang TF, Holt JC, Cook JJ, Niewiarowski S. 1990. Disintegrins: a family of integrin inhibitory proteins from viper venoms. *Proceedings of the Society for Experimental Biology and Medicine*. 195(2), pp168-171.
50. Ritter, M.R., Zhou, Q. and Markland, F.S. Jr. 2001. Contortrostatin, a homodimeric disintegrin actively disrupts focal adhesion and cytoskeletal structure and inhibits cell motility through a novel mechanism. *Cell Adhesion and Communication* 8(2), pp71-86.
51. Cohen, S.A., Trikha, M., and Mascelli, M.A. 2000. Potential future clinical applications for the GPIIb/IIIa antagonist, abciximab in thrombosis, vascular and oncological indications. *Pathology Oncology Research* 6(3), pp163-174.
52. Rust, W.L., Huff, J.L. and Plopper, G.E. 2000. Screening assay for promigratory/antimigratory compounds. *Analytical Biochemistry* 280(1), pp11-19.

Figure 1. Schematic of known integrin-associated signaling pathways. Solid arrows indicate direct association between signaling partners, while dashed arrows indicate associations that may involve the action of unidentified intermediates. Abbreviations: CAMKII, Calmodulin dependent protein kinase II; CAS, crk-associated substrate; FAK, focal adhesion kinase; JNK, Jun kinase; Myosin Light Chain-P, phosphorylated myosin light chain; PI3K and PI4K, phosphatidylinositol 3 (or 4) kinase; PKC, protein kinase C; TM4SF, tetraspan superfamily of proteins.

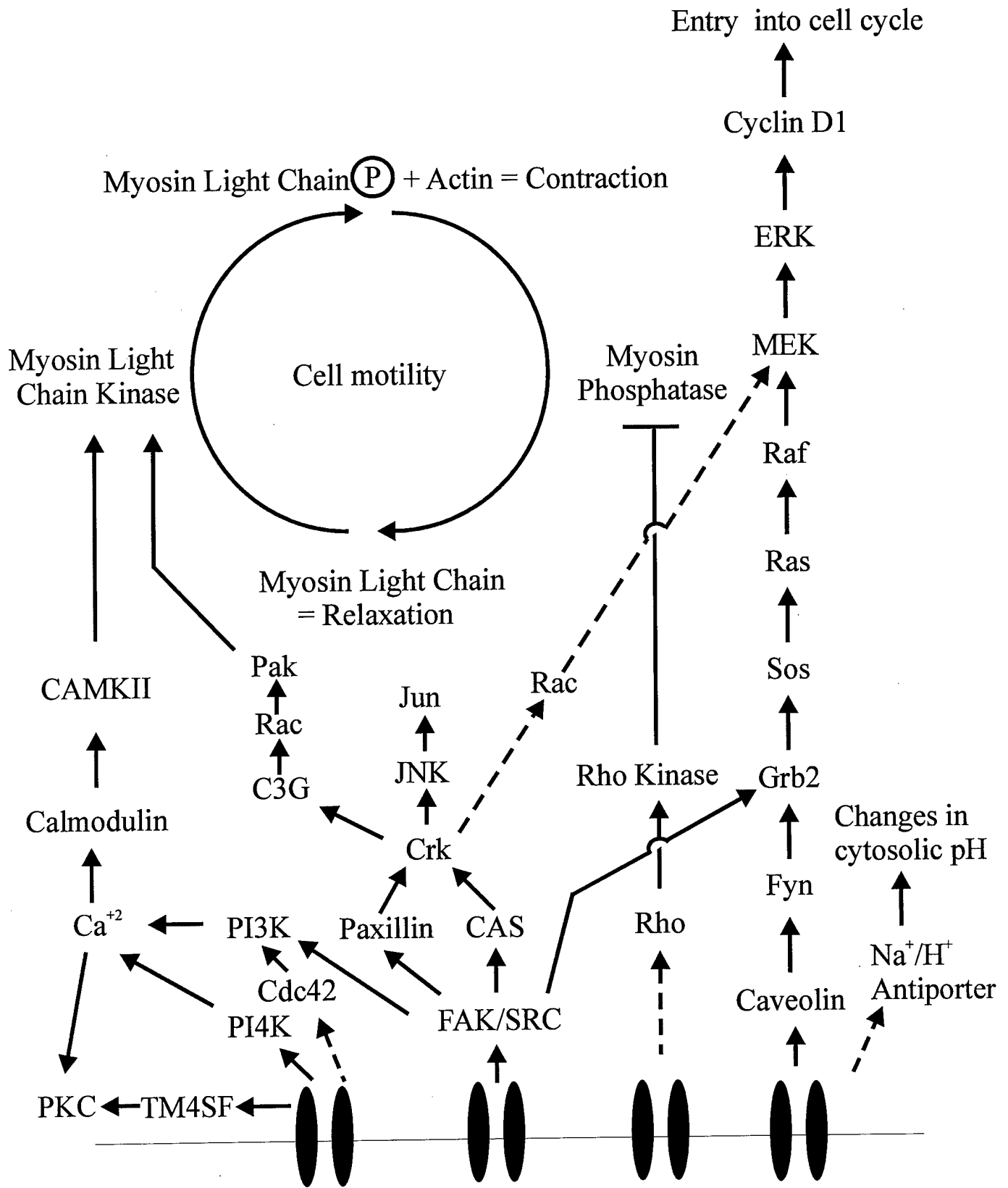

Figure 1

**SPECIFICATION**

**TITLE OF THE INVENTION**

Method for predicting the efficacy of anti-cancer drugs.

**CROSS-REFERENCE TO RELATED APPLICATIONS**

Not applicable.

**STATEMENT REGARDING FEDERALLY SPONSORED RESEARCH OR  
DEVELOPMENT**

Not applicable.

**REFERENCE TO A MICROFICHE APPENDIX**

Not applicable.

## BACKGROUND OF THE INVENTION

### Field of the invention.

This invention relates generally to assays for predicting the chemosensitivity of tissues to particular drugs, and more specifically, to a method capable of measuring both the anti-migratory effect and cytotoxic effect of drugs on tissues in vitro.

### Description of prior art.

Solid tissue cancers are broadly defined by two general characteristics. These characteristics are: (1) a mass of hyperproliferating cells of clonal origin, and (2) acquisition of an aggressively invasive phenotype, wherein cancer cells leave the tissue of origin and establish new tumor metastases at distant sites. Current methods for evaluating the effect of accepted and experimental anti-cancer drugs on human cancers focus on measuring the arrest of hyperproliferation or the stimulation of cell death, both markers of the first characteristic of cancer cells. In general, these methods require that single cells be isolated from a tumor biopsy and grown in culture. The cells are then exposed to a drug, and after a certain amount of time has elapsed, cytostatic or cytotoxic effects are measured. These measurements are made in many ways, including: incorporation of the toxic substance, inducement of programmed cell death (termed apoptosis), depletion of intracellular metabolites such as adenosine triphosphate (ATP), depression of cell growth, and compromise of the cell membrane.

The most significant drawback of these methods is the inability to assess the effect of anticancer drugs on the second, and most lethal, characteristic of cancers, the invasive characteristic that leads to establishment of tumors at distant sites. Other drawbacks include:

1. The requirement to grow/expand biopsy cells in culture before testing allows selective expansion of subsets of tumor cells that are not necessarily representative of the entire tumor. In addition, many biopsies suffer from low plating efficiency, precluding them from being tested.
2. Measurements of cellular metabolism cannot discriminate cells that are injured and will recover from those which are truly dead.
3. Assays using differential staining techniques are subject to individual interpretation, and frequently cannot distinguish live cells from cellular debris.
4. All assays that measure a single biochemical endpoint, such as cell proliferation or inhibition of DNA synthesis are limited by the particular characteristics of that endpoint, and do not accurately reflect cell survival.
5. These assays suffer from long turn-around time, ranging from 5 days to several weeks.

Therefore, it would be desirable to provide an alternative assay for measuring the chemosensitivity of cancer biopsies that does not require the expansion of cells in culture, can assess the effect of anticancer drugs on both the hyperproliferation and invasive characteristics of human cancers, that is not dependent on cell metabolism or differential staining, and can be performed quickly with a minimum of manipulations.

Alternative assays proposed to predict the chemosensitivity of biopsies in vitro are: U.S. Pat. No.4,816,395, U.S. Pat. No.4,937,182, A review of several chemosensitivity assays that use metabolite production and hyperproliferation analysis as chemosensitivity determinants is given by Bellamy, W.T., Prediction of response to drug therapy of cancer. A review of in vitro assays. *Drugs* 44(5): pp 690-708, (1992), Sevin, B.U., et al., Current status and future directions of

chemosensitivity testing. *Contrib Gynecol Obstet* 19: pp179-194, (1994), and Cramer, A.B., et al., Chemosensitivity testing: a critical review. *Crit Rev Clin Lab Sci* 28(5-6): pp 405-413 (1991), Hoffman, R.M., In vitro assays for chemotherapy sensitivity. *Crit Rev Oncol Hematol* 15(2): pp 99-111, (1993). A chemosensitivity assay using radioactive nucleotide incorporation is given by Kitaoka A., et al, Improvement of in vitro chemosensitivity assay for human solid tumors by application of a preculture using collagen matrix. *Clin Cancer Res* 3(2): pp 295-299, (1997). A method using DNA synthesis as an indicator of cell growth is given by Kawabata, K. et al., Anticancer chemosensitivity and growth rate of freshly separated human colorectal cancer cells assessed by in vitro DNA synthesis inhibition assay. *Anticancer Res* 18(3A): pp 1633-1640 (1998). Chemosensitivity assays that measure cell viability by cellular metabolism are: Furukawa, T., et al., Clinical applications of the histoculture drug response assay. *Clin Cancer Res* 1(3): pp 305-311, (1995), and Kawamura, H., et al., The usefulness of the ATP assay with serum-free culture for chemosensitivity testing of gastrointestinal cancer. *Eur J Cancer* 33(6): pp 960-966, (1997). An embodiment of the present invention is described in Rust, W.L., Screening assay for promigratory/antimigratory compounds. *Anal Biochem* 280(1) pp 11-19, (2000). Each of these suffers from at least one of the disadvantages listed above.

The present invention takes advantage of a newly developed procedure for automatically measuring cell migration described by Tchoo, U.S. Pat. No. 5,601,997 but incorporates modifications of the procedure that allows it to efficiently adapted for the novel use described. The present invention incorporates for novel use the cell death determination procedure described by Nieminen, A.L., A novel cytotoxicity screening assay using a multiwell fluorescence scanner. *Toxicol Appl Pharmacol* 115(2): pp 147-155, (1992).

## BRIEF SUMMARY OF THE INVENTION

The present invention provides the first efficient method for simultaneously measuring the anti-migratory effect and cytotoxic effect of drugs on biopsy cells without the need to expand the cells in culture. This assay is useful for predicting the chemosensitivity of an individual patient's cancer to therapeutic drugs. This assay is unique among chemosensitivity assays for the ability to measure both the anti-migratory and cytotoxic effects of drugs. Because the formation of solid tissue cancer is dependent upon the invading cells' ability to migrate across tissues as well as hyperproliferation, a chemosensitivity assay that measures both the anti-migratory and cytotoxic effect of drugs is a more comprehensive and more sensitive method for determining the chemosensitivity of biopsies than other assays. Obviating the need to expand cells in culture reduces the risk of experimental factors which can bias the assay outcome, and allows the assay to be performed more quickly than current methods.

In the present invention, biopsy samples are dissociated into individual cells which are exposed to anticancer drugs and introduced into the top chamber of a migration assay apparatus. A stimulant induces the cells to migrate across a porous membrane. After a period of time, migrated cells are labeled with a live cell fluorescent indicator and non-migrated cells are labeled with a fluorescent indicator of cell death. The fluorescence of both fluorophores are measured in a fluorescence plate reader. The fluorescence intensity of the cell death reporter indicates the sensitivity of the cells to cytotoxic effects of the drugs. The fluorescence emitted from the migrated cells indicates the ability of the biopsy cells to migrate in the presence of the drugs.

Significant differences between the present invention and the procedure described by Tchao in U.S. patent no. 5,601,997 include that the cells must not be pre-labeled as the presence of a chemical dye can influence migration behavior and might interact with the chemical agent

being tested. This assay is not intended to for kinetic analysis of the migratory behavior of cells.

In addition, the incorporation of a cytotoxic assay into the procedure is entirely novel.

## BRIEF DESCRIPTION OF THE SEVERAL VIEWS OF THE DRAWING

Fig. 1 is a flow chart illustrating each step of the present invention for predicting the efficacy of anti-cancer drugs on human tissues.

Fig. 2 is a diagram of the test chambers of a suitable migration plate apparatus for use in the present invention. This diagram is offered by way of illustration, not by way of limitation.

Fig. 3 is a comparison of the sensitivity of human breast cancer cells to the anti-migratory and cytotoxic effects of two anticancer drugs. The anticancer drugs compared are the common anticancer drug tamoxifen (Fig. 3A) and an experimental anticancer drug carboxyamido-triazole (Fig. 3B). Breast cancer cells were allowed to migrate towards serum (chemotaxis) or fibronectin (haptotaxis) in the presence of tamoxifen (a) and carboxyamido-triazole (CAI) (B). After 18 hours, migrated cells were labeled with calcein-AM and fluorescence quantitated from the bottom. Nonmigrated cells were labeled with propidium iodide and fluorescence quantitated from the top. Estimation of 100% cell death was made by lysing cells in a test chamber with 1% Triton X-100 (TX 100) Error bars represent the standard deviation of 4-16 replicate test chambers. Asterisks represent a significant difference from migration without drugs ( $P < 0.05$ ).

RFU=relative fluorescence units.

## DETAILED DESCRIPTION OF THE INVENTION

The present invention is an assay for simultaneously and automatically measuring the anti-migratory and cytotoxic properties of anticancer drugs on human tissues. This assay is useful for predicting the chemosensitivity of biopsy samples to various chemical agents or combinations of chemical agents.

A flow chart describing the steps of the present invention is provided in Fig 1. A figure showing the essential aspects of the apparatus used in this procedure is given for illustration in Fig 2. An example of an adequate migration plate is described by U.S. Pat. no. 5,801,055. 1 (Fig 1) The cells of a biopsy are disaggregated by gentle mechanical agitation and/or proteolytic digestion in a serum free medium suitable for maintaining the cells in culture. 2,3 (Fig 1) The cells are exposed to an anticancer chemical agent and introduced into the first chamber 8 (Fig 2) of a migration plate. The anticancer drug is directly added to the cell suspension to reach a final concentration typically in the range of 1 to 100  $\mu$ Molar. The top chamber of the migration plate is separated from a second chamber by an electromagnetic radiation opaque membrane having a plurality of substantially perpendicular transverse pores 9 (Fig 2). A migration stimulus is added to the second chamber 10 (Fig 2). This stimulus may be a chemotactic stimulus, (a chemical dissolved in the medium of the second chamber), or a haptotactic stimulus, (a non-solubilized molecule adhered to the radiation opaque membrane on the side facing the second chamber). 4 (Fig 1) The cells are allowed to migrate in the appropriate conditions (temperature, pH, humidity, and carbon dioxide concentration) from the first chamber through the pores of the radiation opaque membrane towards the second chamber. Conditions suitable to maintain human tissues are 37°C, pH 7.4, 5% carbon dioxide. After a predetermined amount of time, typically 4-24 hours, the cells adhered to the side of the membrane facing the second chamber are labeled

with a live-cell fluorescent indicator. **5** (Fig 1) The non migrated cells which remain adhered to the side of the membrane facing the first chamber are labeled with a fluorescent indicator of cell death. The fluorophores are added directly to the medium to reach a final concentration typically from 1-50 micro Molar. Live cell fluorescent indicator suitable for quantitating migrated cells include metabolic dyes such as calcein-AM, membrane dyes such as DiO, DiI, or fluorescent microspheres that are spontaneously endocytosed by live cells. Fluorescent indicators suitable for quantifying cell death include ethidium bromide and propidium iodide. The mechanism of action of these indicators is the enhancement of fluorescence intensity upon binding deoxyribonucleic acid (DNA). These dyes easily permeate the compromised membranes of dead cells but are largely excluded from live cells. The fluorophores must be chosen such that the migration plate membrane is opaque to either the excitation or emission or both wavelengths of the fluorophore.

**6** (Fig 1) The intensity of the electromagnetic radiation emitted from the fluorophores on either side of the membrane are measured in a fluorescence plate reader. An example of a suitable fluorescence plate reader is the SpectraFluor manufactured by TECAN (Research Triangle Park, NC).

**7** (Fig 1) The last step of the invention is the analysis of the emitted fluorescence data. The fluorescence emitted from the live cell fluorescent indicator on the side of the membrane facing the second chamber **11** (Fig 2) is an indicator of the amount of cells that have migrated across the filter. The fluorescence emitted from the fluorescent indicator of cell death on the side of the membrane facing the first chamber **12** (Fig 2) is an indicator of the amount of cells that are not viable. The strength of these signals indicate the chemosensitivity of the cells to the drug being tested. A strong relative emission from the first chamber indicates sensitivity to cell death induced by the chemical. A weak relative emission from the second chamber indicates sensitivity to inhibition of migration induced by the chemical. The data offer meaningful predictions of

chemosensitivity of the cancer cells when compared to appropriate drug-free controls and to other drugs.

A potential limitation of the method described is the contamination of biopsy samples by non-tumorigenic cells that could potentially influence assay results. Epithelial cultures, in particular, are prone to fibroblast contamination and this cell type predominates the colon, breast, and lung cancer biopsies. The extent of fibroblast contamination can be determined by double immunofluorescence staining using antibodies specific for the intermediate filament protein subunits vimentin (as a marker for fibroblasts) and keratin (for epithelial cells).

The methods of the present invention are useful with a wide variety of cells. These include solid tumor cells of biopsies derived from breast, colorectal, lung, and other tissues, and hematopoietic cells. The tumor cells may be of epithelial origin (carcinomas), arise in the connective tissue (sarcomas), or arise from specialized cells such as melanocytes (melanomas) and lymphoid cells (lymphomas), and the like. The cells may be derived from primary tumors or metastatic tumors.

The anti-cancer drugs which may be assessed by the assay of present invention include natural or synthetic, common or experimental drugs. Compounds which are only effective after being metabolised by the body must be used in their active conformation.

The following examples are offered by way of illustration, not by way of limitation.

## Experimental

Upon biopsy and/or surgical removal, tumor samples were aseptically transferred to tubes containing RPMI 1640 cell culture media (Irvine Scientific, Santa Ana, CA) supplemented with

penicillin (100U/ml) and streptomycin (100µg/ml). Sample size was approximately 1 cm in diameter. Tissues were minced with a sterile razor into pieces less than 1mm<sup>3</sup>. Single cells were separated from tissue fragments by filtration through two sheets of sterile gauze (16XX mesh). Cells were collected by centrifugation and washed with phosphate buffered saline, repelleted and resuspended in migration media. Migration media consists of Dulbecco's modified eagle's medium (DME, Irvine Scientific, Santa Ana, CA) supplemented with 1mM sodium pyruvate and 292 µg/ml L-glutamine, 100 U/ml penecillin, and 100 µg/ml streptomycin. For proteolytic digestion, tissues were first minced into approximately 3 mm<sup>3</sup> pieces and added to media containing collagenase and dispase and incubated for approximately 30 minutes at 37°C with gentle agitation. The cells were then allowed a rest period ranging from 1 to 12 hours in a humidified incubator maintained at 37° C and 5% carbon dioxide.

Cell suspension was added to the first chamber of a migration plate containing 96 chambers per plate at a concentration of 80,000 cells per chamber. The migration plate used in this assay was manufactured by Polyfiltronics. Similar plates are available from Becton-Dickinson (U.S. Pat no. 5,801,055). The second chamber contained either haptotactic stimulus in the form of 20µg/ml fibronectin or chemotactic in the form of 5% fetal calf serum. Cells were allowed to migrate in a humidified incubator at 37°C and 5% carbon dioxide for twelve hours. During the last half hour of the incubation, calcein-AM (Molecular Probes, Eugene, OR) was added to the second chamber to a final concentration of 5µM and propidium iodide was added to the first chamber to a final concentration of 30µM. At the end of the incubation the underside of the filters were washed twice in phosphate buffered saline. Fluorescence from each individual well chamber was measured from the bottom using 485 nm excitation and 530 nm emission filters. Fluorescence from each individual well chamber was measured from the top using 560

nm excitation and 645 nm emission wavelength filters using a Tecan SpectraFluor fluorescent plate reader (Research Triangle Park NC).

Fig. 3 demonstrates the influence of tamoxifen and carboxyamido triazole (CAI) on the migration and viability of highly metastatic breast cells. The dynamics of inhibition of migration are different than cytotoxic effects caused by drug exposure (Figs. 3A, 3B). Both haptotactic and chemotactic migration are inhibited at lower concentrations than those that cause cell death for both tamoxifen and CAI (Figs. 3A, 3B). Tamoxifen and CAI inhibited migration in a dose-dependent manner at sublethal concentration, and CAI was more effective than tamoxifen at halting migration. Haptotactic migration on fibronectin was more sensitive to drug effects than chemotactic migration. Cells exposed to 10 $\mu$ M CAI demonstrated 32% inhibition of haptotaxis and 7% inhibition of chemotaxis. At 20 $\mu$ M, CAI abolished haptotaxis and inhibited chemotaxis by 42% (Fig. 3B). Cells exposed to tamoxifen demonstrated non-significant inhibition of chemotaxis and haptotaxis at 10 $\mu$ M, and only 51% inhibition of haptotaxis and 9% inhibition of chemotaxis at 20 $\mu$ M (Fig. 3A). These cells were more sensitive to the cytotoxic effects of tamoxifen than CAI as evidenced by the increased propidium iodide fluorescence (Fig. 3A, 3B). The asterisks represent a significant difference from positive control ( $p < 0.05$ ).

#### Alternative Embodiments.

With the following modifications, the present invention is useful as a tool for discovery of novel anticancer compounds and cancer preventative compounds. A cancer preventative compound is described here as a drug that substantially inhibits the migration of cancer cells but does not inhibit cell proliferation. Such a drug would potentially not cause to the patient the side

effects typical of anti-proliferative compounds. These side effects include damage to normal tissues, immune suppression, mucositis, hair loss, nausea, and vomiting.

In this embodiment, established cultured cell lines are used in place of biopsy samples. These cell lines serve as representative examples of human cancers from a range of tissues such as breast, lung, bone, colon, prostate, etc... Experimental compounds are added to suspensions of cultured cells to reach a final concentration typically in the range of 1-100 $\mu$ M. These compounds are typically stored in dimethyl sulfoxide, a chemical toxic to cells. For that reason, care must be taken to limit the dimethyl sulfoxide concentration to an amount not harmful to the cells, typically < 50 $\mu$ M. The chemosensitivity assay is performed as described in the main embodiment. Promising anticancer compounds are defined as those which substantially inhibit migration and induce cell death in a cancer cell type. Promising cancer preventative compounds are defined as those that inhibit cell migration without inducing cell death.

#### Conclusion, Ramifications, and Scope.

The present invention of a method for quantifying the chemosensitivity of cancer cells to anticancer compounds has the following advantages over other chemosensitivity assays. The present invention measures an endpoint characteristic of metastasis formation, a feature unique among chemosensitivity assays. The present invention measures two endpoints of anticancer effect instead of just one, making the assay more comprehensive, and not specific to one cell response. The present invention does not require that biopsy cells be expanded in culture, thus shortening the time frame of the assay and avoiding the bias that culturing causes by selecting a subset of biopsy cells. Also, the present invention has the advantage over most other

chemosensitivity assays in that results are quantified automatically, thus avoiding the bias inherent in subjective sampling by humans.

While my above description contains many specifics, these should not be construed as limitations on the scope of the invention, but rather as an exemplification of one preferred embodiment thereof. Many other variations are possible. For example, the type of cells used or drug characteristics are unimportant to the method. The type of fluorescent cell labels used are also of little importance, as long as they can be readily detected by a fluorescence plate reader, and as long as the radiation opaque membrane of the migration plate is opaque to either the excitation or emission wavelengths of the fluorophore. The specific design or manufacture of the migration plate is unimportant as long as two suitable test chambers are separated by a radiation opaque membrane with pore sizes appropriate for the migration of the cell type being tested (typically 4-10 $\mu$ m).

## CLAIMS

1. What I claim as my invention is a method for predicting the efficacy of anti-cancer drugs wherein both the cytotoxic and anti-migratory effects of the drug are measured, said assay comprising:

- a. a biopsy is disaggregated into individual cells to form a cell suspension;
- b. said cells are exposed to a drug;
- c. said cells are added to the first chamber of a migration plate comprising two chambers separated by a porous membrane, said porous membrane being opaque to radiation;
- d. placing a chemical agent in the second chamber, said agent being capable of inducing migration of said labeled cells from said first chamber to said second chamber;
- e. incubating cells to allow cell migration to occur;
- f. labeling cells on the side of the membrane closest to said second chamber with a fluorescent dye, said dye being capable of labeling only live cells;
- g. labeling cells on the side of the membrane closest to said first chamber with a fluorescent dye, said dye being capable of labeling only dead cells;
- h. stimulating the labeled cells on the side of the membrane closest to said second chamber with electromagnetic radiation of a first wavelength whereby said labeled cells will emit electromagnetic radiation of a second wavelength; and
- i. measuring the emitted electromagnetic radiation from the side of the radiation opaque membrane closest to said second chamber;
- j. stimulating the labeled cells on the side of the membrane closest to said first chamber with electromagnetic radiation of a first wavelength whereby said labeled cells will emit electromagnetic radiation of a second wavelength; and

- k. measuring the emitted electromagnetic radiation from the side of the radiation opaque membrane closest to said first chamber, whereby the effect of said drug on said cell migration and said cell death is an indication of the effectiveness of said drug at arresting said cancer tissues.
2. The procedure of claim 1, wherein the side of the membrane closest to the second chamber is coated with a fixed material capable of inducing migration.
3. The procedure of claim 1, wherein the fluorescent dye capable of labeling only live cells is metabolically activated.
4. The procedure of claim 1, wherein the fluorescent dye capable of labeling only live cells is embedded in a material endocytosed only by live cells.
5. The procedure of claim 1, wherein steps (h) and (j) comprises measuring the electromagnetic radiation with a fluorescent plate reader.
6. The procedure of claim 1, wherein drugs are tested against established cells lines, thus omitting step (a).

## ABSTRACT OF THE DISCLOSURE

A method for measuring both the anti-migratory and cytotoxic effects of anticancer drugs on human cancer tissues. This method is useful for predicting the chemosensitivity of human biopsies to therapeutic drugs. Single cell suspension preparations of biopsy tissue is exposed to anticancer drugs and introduced into the first chamber of a migration plate. The first chamber is separated from a second chamber by a porous membrane that is opaque to radiation. A migration stimulus is added to the second chamber and the cells are allowed to migrate. Migrated cells on the side of the membrane facing the second chamber are labeled with a live-cell fluorescent indicator. Non-migrated cells on the side of the membrane facing the first chamber are labeled with a fluorescent indicator of cell death. The emitted fluorescence of both the migrated cells and the non-viable cells is quantified in a fluorescence plate reader. Compared to cells not exposed to drugs, intensity of fluorescence from cell death label in the first chamber is an indicator of the susceptibility of the cells to the cytotoxic properties of the drug. The intensity of fluorescence from the live cell indicator of the second chamber is an indicator of the susceptibility of the cells to the anti-migratory properties of the drug. This assay is particularly useful for predicting the capability of a drug to stop both the growth of a tumor as well as the progression of a tumor to metastatic cancer.

## DRAWINGS

Fig. 1

1. Disaggregate biopsy cells
2. Expose cells to drug
3. Add cell suspension to first chamber of migration plate
4. Incubate
5. Label cells with a live cell fluorescent indicator and a fluorescent indicator of cell death
6. Quantitate fluorescence of each fluorophore
7. Analyze data

Fig. 2 (prior art)

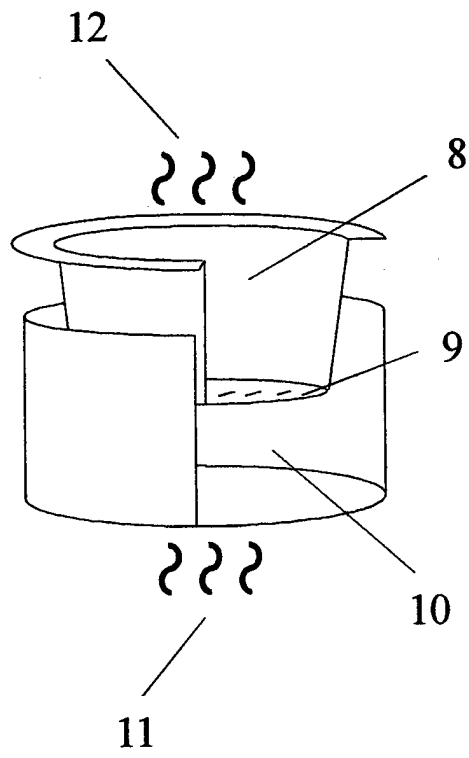

Fig. 3A

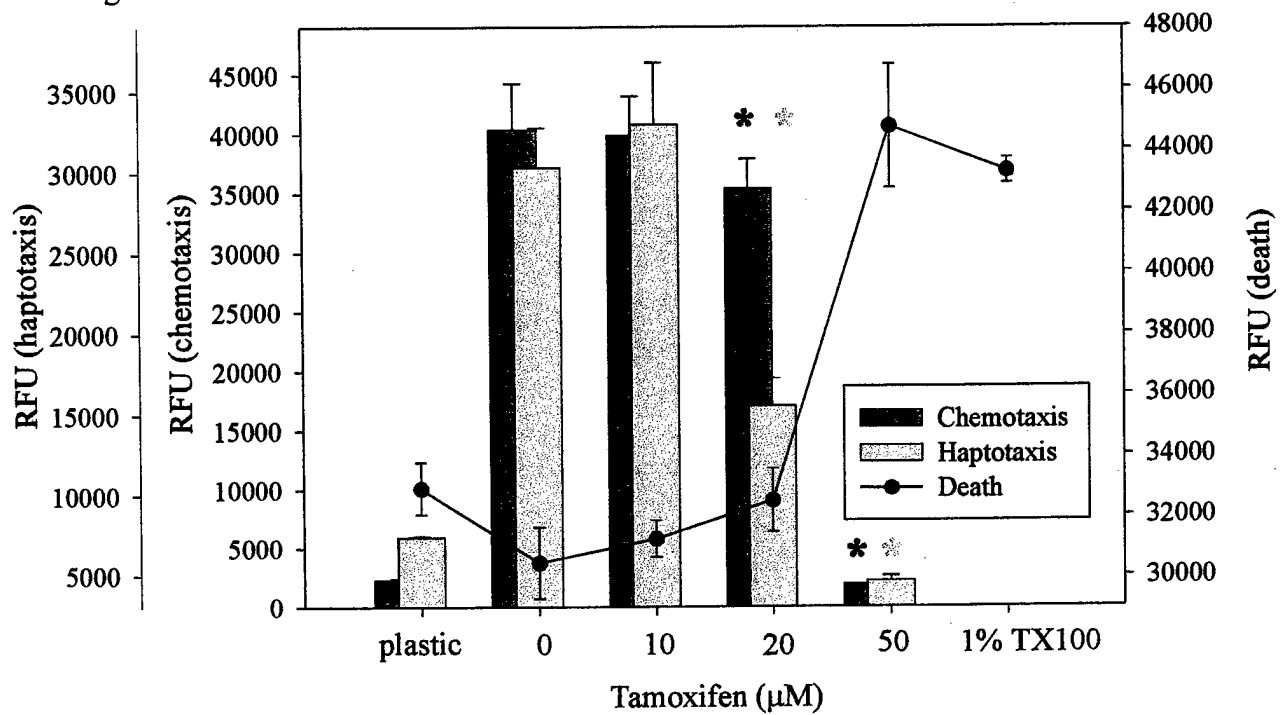

Fig. 3B

