

**FINAL REPORT
DECEMBER 2002**

REPORT NO. 02-15



**NAILED FLOOR-LINE BLOCKING METHODS
TP-94-01,
"TRANSPORTABILITY TESTING PROCEDURES"**

Prepared for:

Director
U.S. Army Defense Ammunition Center
ATTN: SOSAC-DET, Bldg 35
McAlester, OK 74501-9053

Distribution Unlimited:



**VALIDATION ENGINEERING DIVISION
MCALESTER, OKLAHOMA 74501-9053**

20030128 188

AVAILABILITY NOTICE

A copy of this report will be furnished each attendee on automatic distribution. Additional copies or authority for reprinting may be obtained by written request from:

Director
U.S. Army Defense Ammunition Center
ATTN: SOSAC-DEV
1 C Tree Road, Bldg. 35
McAlester, OK 74501-9053

Reports may also be downloaded or viewed in PDF format from our web site at:

<http://www/dac.army.mil/DEV/TestReports>

DISTRIBUTION INSTRUCTIONS

Destroy this report when no longer needed. Do not return.

Citation of trade names in this report does not constitute an official endorsement.

The information contained herein will not be used for advertising purposes.

U.S. ARMY DEFENSE AMMUNITION CENTER

VALIDATION ENGINEERING DIVISION
MCALESTER, OK 74501-9053

REPORT NO. 02-15

Nailed Floor-Line Blocking Methods
TP-94-01, "Transportability Testing Procedures"

TABLE OF CONTENTS

PART	PAGE NO.
1. INTRODUCTION	1-1
A. BACKGROUND.....	1-1
B. AUTHORITY.....	1-1
C. OBJECTIVE	1-1
D. CONCLUSION	1-1
2. ATTENDEES.....	2-1
3. TEST EQUIPMENT.....	3-1
4. TEST PROCEDURES	4-1
A. ON/OFF ROAD TEST.....	4-1
1. HAZARD COURSE	4-1
2. ROAD TRIP	4-2
3. PANIC STOPS.....	4-3
4. WASHBOARD COURSE	4-3
5. TEST RESULTS	5-1
5.1 TESTING DATE (7 MAY 2002).....	5-1
A. ON/OFF ROAD TEST. HAZARD COURSE	5-2
B. CONCLUSIONS	5-4
5.2 TESTING DATE (9 MAY 2002).....	5-5
A. ON/OFF ROAD TEST. HAZARD COURSE	5-5
B. CONCLUSION.....	5-7
5.3 TESTING DATE (9 MAY 2002).....	5-8
A. ON/OFF ROAD TEST. HAZARD COURSE	5-8
B. CONCLUSION.....	5-9

5.4 TESTING DATE (20 MAY 2002)	5-10
A. ON/OFF ROAD TEST	5-10
1. HAZARD COURSE	5-10
2. ROAD TRIP	5-11
3. PANIC STOPS	5-11
4. HAZARD COURSE	5-11
5. WASHBOARD COURSE	5-11
B. CONCLUSION	5-13
5.5 TESTING DATE (13 AUGUST 2002)	5-14
A. ON/OFF ROAD TEST	5-14
1. HAZARD COURSE	5-14
2. ROAD TRIP	5-15
3. PANIC STOPS	5-15
4. HAZARD COURSE	5-16
5. WASHBOARD COURSE	5-16
B. CONCLUSION	5-16
5.6 TESTING DATE (16 AUGUST 2002)	5-17
A. ON/OFF ROAD TEST	5-17
1. HAZARD COURSE	5-17
2. ROAD TRIP	5-18
3. PANIC STOPS	5-18
4. HAZARD COURSE	5-18
5. WASHBOARD COURSE	5-19
B. CONCLUSION	5-20
5.7 TESTING DATE (22-26 AUGUST 2002)	5-21
A. ON/OFF ROAD TEST	5-21
1. HAZARD COURSE	5-21
2. ROAD TRIP	5-22
3. PANIC STOPS	5-23
4. HAZARD COURSE	5-23
5. WASHBOARD COURSE	5-24
B. CONCLUSION	5-25
6. ACCELEROMETER DATA	6-1
7. DRAWINGS	7-1

**REPORT NO. 02-15
NAILED FLOOR-LINE BLOCKING METHODS
TP-94-01, "TRANSPORTABILITY TESTING PROCEDURES"**

DECEMBER 2002

ABSTRACT

The U.S. Army Defense Ammunition Center (DAC), Validation Engineering Division (SOSAC-DEV), was tasked by the Transportation Engineering Division (SOSAC-DET) to conduct transportability testing of Nailed Floor-Line Blocking Methods. The testing was conducted in accordance with TP-94-01, "Transportability Testing Procedures", with the exception that the washboard course testing was optional.

The Nailed Floor-Line Blocking Methods used during testing on 20 May 2002, 13 August 2002, 16 August 2002, and 22-26 August 2002 successfully completed the Hazard Course Testing and the Road Trip Testing as specified in TP-94-01, "Transportability Testing Procedures". The nailing criteria and procedures for the nailed floor line blocking methods utilized during the successful testing are adequate and safe for transportation of ammunition in closed van trailers for highway movement. The nails that were utilized during the successful testing were hand driven and conformed to the ASTM F1667 requirements for common steel nails.

Prepared by:

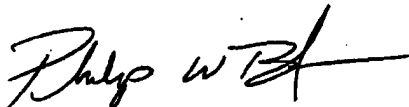

PHILIP W. BARICKMAN
Lead Validation Engineer

Reviewed by:

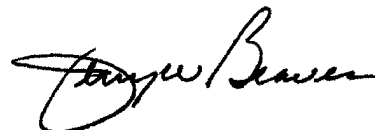

JERRY W. BEAVER
Chief, Validation Engineering Division

PART 1 – INTRODUCTION

A. BACKGROUND. The U.S. Army Defense Ammunition Center (DAC), Validation Engineering Division (SOSAC-DEV), was tasked by the Transportation Engineering Division (SOSAC-DET) to conduct transportability testing of Nailed Floor-Line Blocking Methods. The testing was conducted in accordance with TP-94-01, "Transportability Testing Procedures," with the exception that the Washboard Course was optional.

B. AUTHORITY. This test was conducted IAW mission responsibilities delegated by the U.S. Army Operations Support Command (OSC), Rock Island, IL. Reference is made to the following:

1. AR 740-1, 15 June 2001, Storage and Supply Activity Operation.
2. IOC-R, 10-23, Mission and Major Functions of USADAC, 7 January 1998.

C. OBJECTIVE. The objective of the testing was to validate adequacy of the Nailed Floor-Line Blocking Methods as designed by the Transportation Engineering Division.

D. CONCLUSION. The Nailed Floor-Line Blocking Methods used during testing on 20 May 2002, 13 August 2002, 16 August 2002, and 22-26 August 2002 successfully completed the Hazard Course Testing and the Road Trip Testing as specified in TP-94-01, "Transportability Testing Procedures". The nailing criteria and procedures for the nailed floor line blocking methods utilized during the successful testing are adequate and safe for transportation of ammunition in closed van trailers for highway movement. The nails that were utilized during the successful testing were hand driven and conformed to the ASTM F1667 requirements for common steel nails.

PART 2 - ATTENDEES

ATTENDEE

MAILING ADDRESS

Philip Barickman
General Engineer
DSN 956-8992
(918) 420-8992

Director
U.S. Army Defense Ammunition Center
ATTN: SOSAC-DEV
1 C Tree Road, Bldg. 35
McAlester, OK 74501-9053

Gregory Willis
Industrial Engineer
DSN 956-8075
(918) 420-8075

Director
U.S. Army Defense Ammunition Center
ATTN: SOSAC-DET
1 C Tree Road, Bldg. 35
McAlester, OK 74501-9053

Walter Gordon
Civil Engineer
DSN 956-8050
(918) 420-8050

Director
U.S. Army Defense Ammunition Center
ATTN: SOSAC-DET
1 C Tree Road, Bldg. 35
McAlester, OK 74501-9053

Michael Bartosiak
Mechanical Engineer
DSN 956-8083
(918) 420-8083

Director
U.S. Army Defense Ammunition Center
ATTN: SOSAC-DET
1 C Tree Road, Bldg. 35
McAlester, OK 74501-9053

Art Stanton
Supervisory Engineer
DSN 449-2947
(732) 866-2947

Naval PHST Center
201 Highway 34 South
Colts Neck, NJ 07722-5023

Richard Eaves
Test Engineer
DSN 449-2906
(732) 866-2906

Naval PHST Center
201 Highway 34 South
Colts Neck, NJ 07722-5023

PART 3 - TEST EQUIPMENT

1. Trailer, Cargo, 48-Foot

Manufacturer: Fruehauf, Detroit, MI

Date of Manufacturer: 10/87

Gross Vehicle Weight

Rating: 68,000 Lbs.

VIN: 1HV04825JJ015705

Model: FB9-F2-48

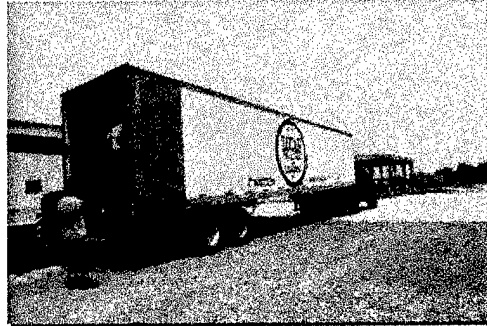

Used for May 2002 Testing

2. Trailer, Cargo, 48-Foot

Manufacturer: Stoughton

Date of Manufacturer: 7/95

Gross Vehicle Weight

Rating: 70,000 Lbs.

VIN: 1DW1A4826TS969383

Model: AVW-485T-S-WEDGE

Used for August 2002 Testing

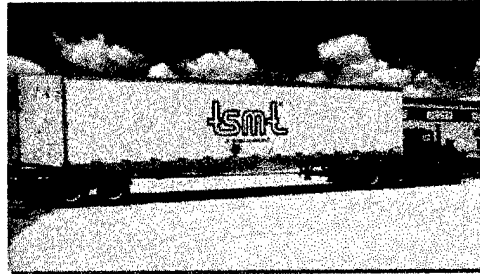

Used for August 2002 Testing

3. Truck, Tractor

5 Ton, 6 X 6

Model #: XM818 with winch

ID #: 05A-74971-C124-13529

Weight: 20,955 Lbs.

PART 4 - TEST PROCEDURES

The test procedures outlined in this section were extracted from TP-94-01, "Transportability Testing Procedures," July 1994, for validating tactical vehicles and outloading procedures used for shipping munitions by tactical truck, railcar, and ocean-going vessel.

Inert (non-explosive) items will be used to build the load. The test loads will be prepared using the blocking and bracing procedures proposed for use with munitions (**see Part 7 for procedures**). The weight and physical characteristics (weights, physical dimensions, center of gravity, etc.) of the test loads will be similar to live (explosive) ammunition.

A. ON/OFF ROAD TEST.

1. **HAZARD COURSE.** The test load or vehicle will be transported over the 200-foot-long segment of concrete-paved road consisting of two series of railroad ties projecting 6 inches above the level of the road surface. The hazard course will be traversed two times (see Figure 1).

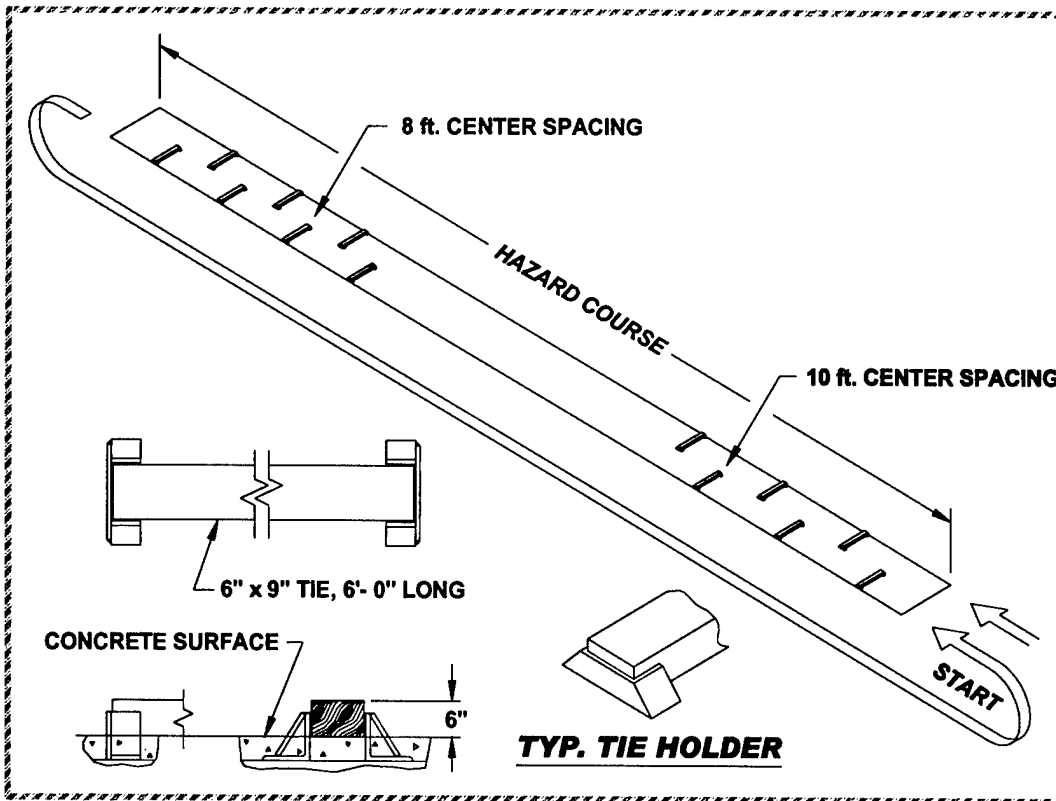

Figure 1. Hazard Course Sketch

- a. The first series of 6 ties are spaced on 10-foot centers and alternately positioned on opposite sides of the road centerline for a distance of 50 feet.
- b. Following the first series of ties, a paved roadway of 75 feet separates the first and second series of railroad ties.
- c. The second series of 7 ties are spaced on 8-foot centers and alternately positioned on opposite sides of the road centerline for a distance of 50 feet.
- d. The test load is driven across the hazard course at speeds that will produce the most violent vertical and side-to-side rolling reaction obtainable in traversing the hazard course (approximately 5 mph).

2. ROAD TRIP. The test load or vehicle will be transported for a distance of 30 miles over a combination of roads surfaced with gravel, concrete, and asphalt. The test route will include curves, corners, railroad crossings and stops

and starts. The test load or vehicle will travel at the maximum speed for the particular road being traversed, except as limited by legal restrictions.

3. **PANIC STOPS.** During the road trip, the test load or vehicle will be subjected to three (3) full airbrake stops while traveling in the forward direction and one in the reverse direction while traveling down an approximate 7 percent grade. The first three stops are at 5, 10, and 15 mph while the stop in the reverse direction is approximately 5 mph. This testing will not be required if the Rail Impact Test is performed.

4. **WASHBOARD COURSE.** The test load or vehicle will be driven over the washboard course at a speed that produces the most violent response in the vertical direction. The washboard course test was conducted for informational purposes only.

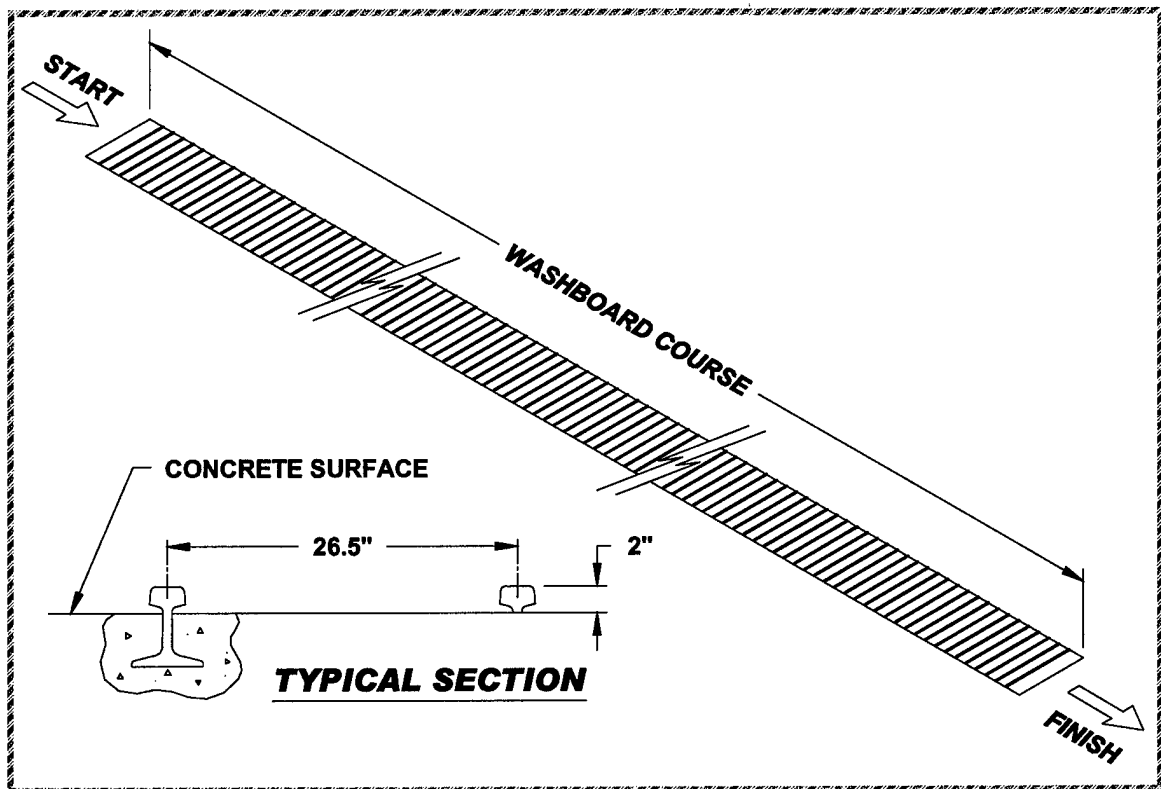

Figure 2. Washboard Course Sketch

PART 5 - TEST RESULTS

5.1 Testing Date: 7 May 2002

Payload: 155MM Separate Loading Projectiles (SLPs)

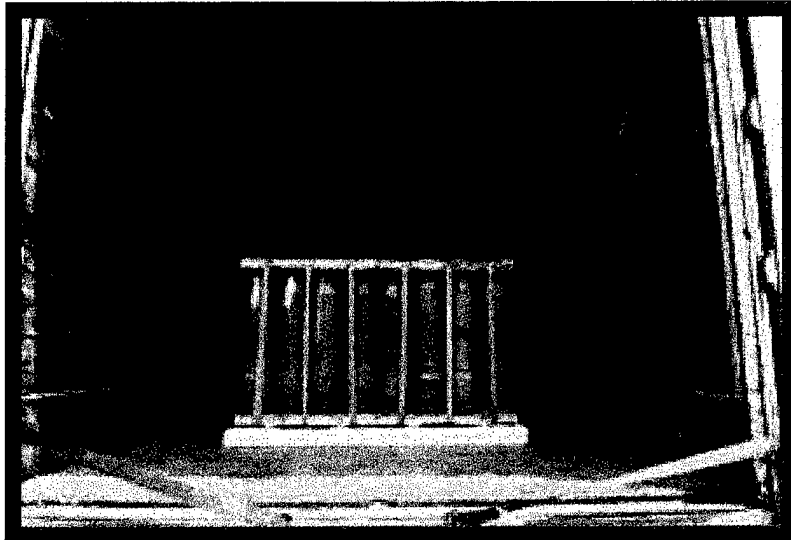

Photo 1. 155MM SLP

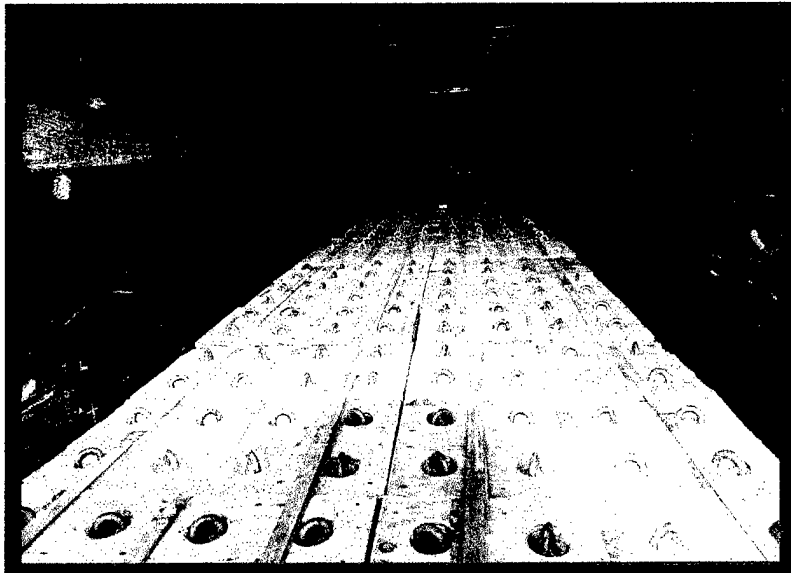

Photo 2. 155MM SLPs Test Load

A. ON/OFF ROAD TEST. HAZARD COURSE.

Pass No.	Elapsed Time	Avg. Velocity (MPH)
1	31 Seconds	5

Figure 2

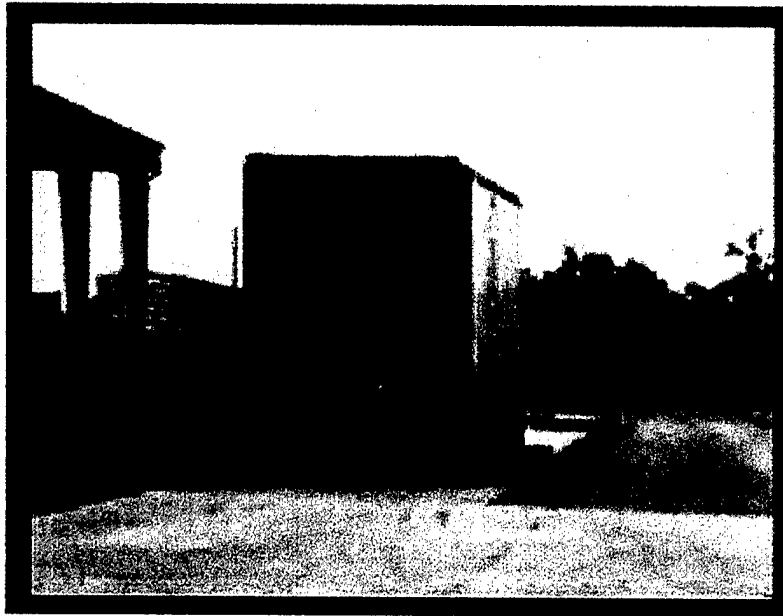

Photo 3. 155MM SLP over Hazard Course

Remarks:

1. Figure 2 lists the average speed of the test load through the Hazard Course.
2. The front header at the door end passenger side moved 2 inches toward the door of the trailer. This permitted the 155MM SLP to move excessively.
3. The side blocking located in the closed end of the trailer on the passenger side pulled loose from the floor. This allowed the 155MM SLP to slide against the trailer wall.
4. Due to the excessive load movement the testing was stopped.



Photo 4. Movement of the Front Header



Photo 5. Movement of the Payload at the Door End of the Trailer

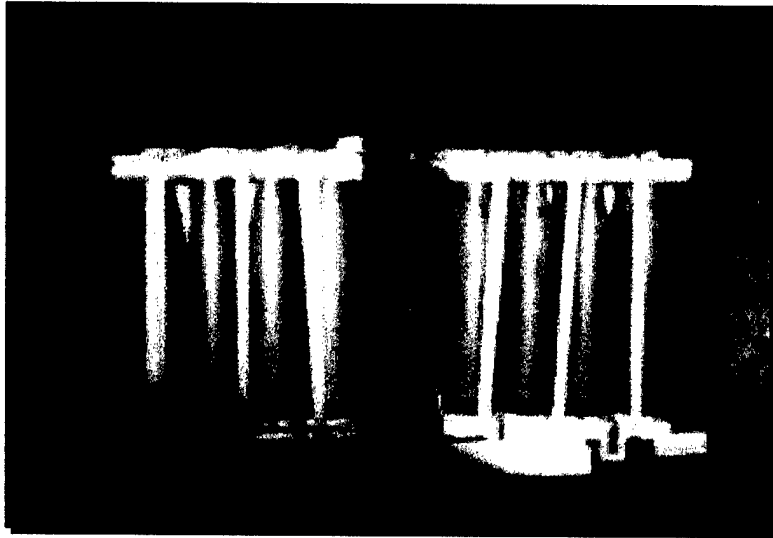

Photo 6. Movement of the Payload at the Closed End of the Trailer

B. CONCLUSION: The nails used to secure the header to the trailer floor were box nails instead of common nails. Therefore, the shank size was not correct. This resulted in a decrease in nail holding ability compared to common nails.

5.2 Testing Date: 9 May 2002

Payload: PA116 Metal Containers on Metal Pallets



Photo 7. PA116 Metal Containers on Metal Pallets Test Load

A. ON/OFF ROAD TEST. HAZARD COURSE.

Pass No.	Elapsed Time	Avg. Velocity (MPH)
1	31 Seconds	5

Figure 3.



Photo 8. Hazard Course Testing of PA116 Containers on Metal Pallets

Remarks:

1. Figure 3 lists the average speed of the test load through the Hazard Course.
2. The top header board at the trailer door separated from the bottom board and the payload was resting on the bottom board upon completion of Pass #1. Due to the failure testing was stopped.

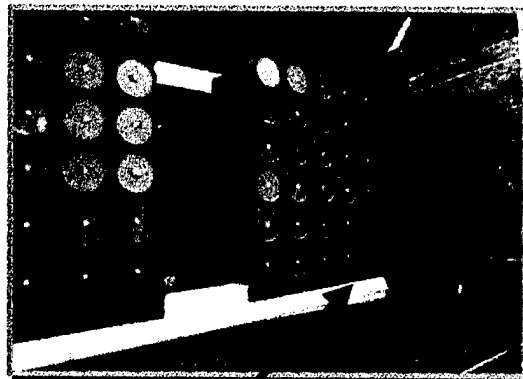
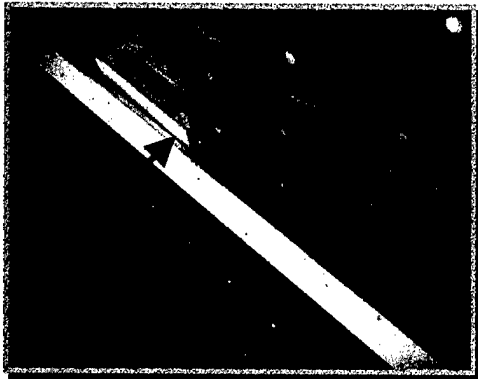

Photos 9 and 10 . Separated Header Board

B. CONCLUSION: The nails used to secure the header to the trailer floor were box nails instead of common nails. Therefore, the shank size was not correct. This resulted in a decrease in nail holding ability compared to common nails.

5.3 Testing Date: 9 May 2002

Payload: PA116 Metal Containers on Metal Pallets

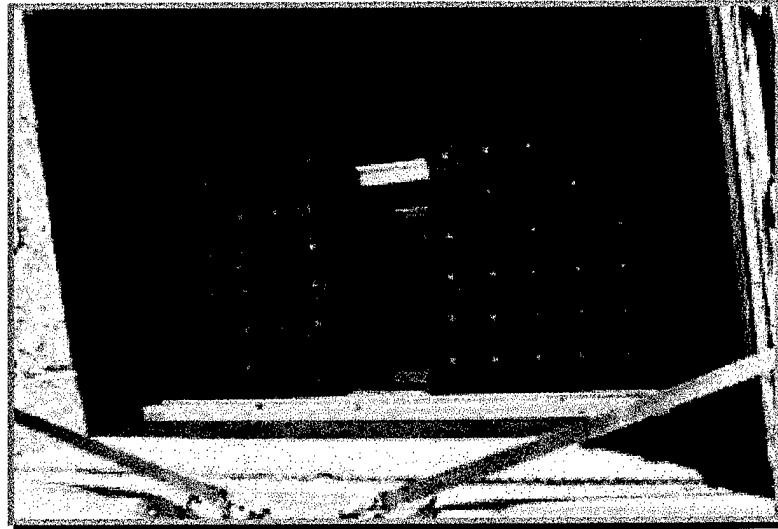

Photo 11. PA116 Metal Containers on Metal Pallets Test Load

A. ON/OFF ROAD TEST. HAZARD COURSE.

Pass No.	Elapsed Time	Avg. Velocity (MPH)
1	26 Seconds	6
2	26 Seconds	6

Figure 4.

Remarks:

1. Figure 4 lists the average speed of the test load through the Hazard Course.
2. A vertical 2" X 4 " board was added between the header boards and the pallet bases.
3. During Pass #2 banding on one pallet at the closed end of the trailer broke and caused the pallet contents to spill onto the trailer floor.

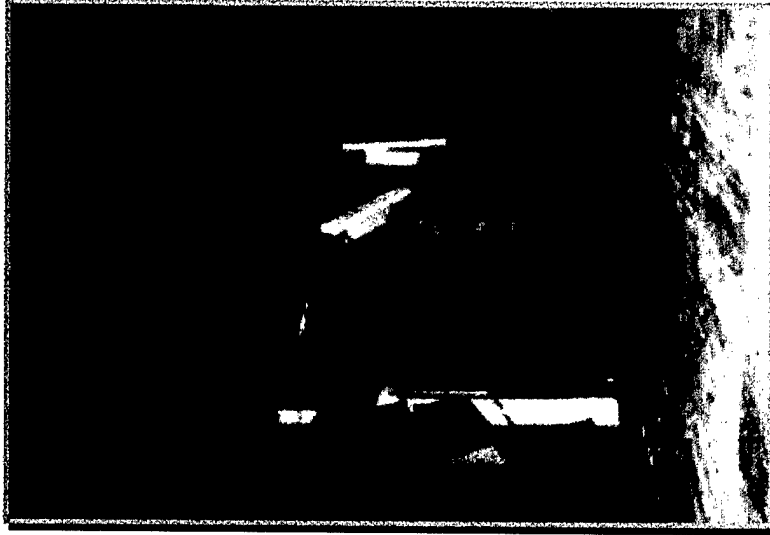

Photo 12. Damaged Pallet Load

B. CONCLUSION: Testing was stopped and the pallet was reloaded and rebanded. In order to accomplish this, all payload and dunnage was removed from the trailer.

5.4 Testing Date: 20 May 2002

Payload: PA116 Metal Containers on Metal Pallets

Note: The payload and nail pattern for this series of tests were the same as Section 5.3.

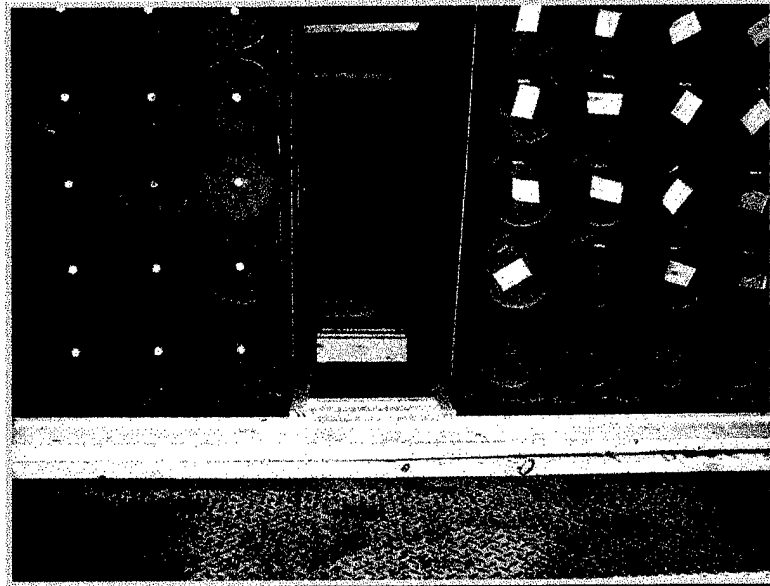

Photo 13. PA116 Metal Containers on Metal Pallets Test Load

A. ON/OFF ROAD TEST.

1. HAZARD COURSE.

Pass No.	Elapsed Time	Avg. Velocity (MPH)
1	30 Seconds	5
2	29 Seconds	5

Figure 5.

Remarks:

1. Figure 5 lists the average speed of the test load through the Hazard Course.
2. Rear bay of payload moved 0.5 toward the trailer door.
3. The 2nd anti-sway brace from the trailer door end came loose from the wire tie.
4. Inspection following Passes # 1 and # 2 revealed no excessive movement of the payload or damage to the trailer or blocking and bracing.

2. **ROAD TRIP:** Inspection revealed no excessive movement of the payload, damage to the trailer or blocking and bracing.

3. **PANIC STOPS:** Inspection revealed no excessive movement of the payload, damage to the trailer or blocking and bracing.

4. **HAZARD COURSE:**

Pass No.	Elapsed Time	Avg. Velocity (MPH)
3	29 Seconds	5
4	29 Seconds	5

Figure 6.

Remarks:

1. Figure 6 lists the average speeds of the test load through the Hazard Course.
2. Inspection following Pass #4 revealed that the load moved 0.5 inches toward the door of the trailer.
3. Inspection following Passes #3 and #4 revealed no excessive movement of the payload or damage to the trailer or blocking and bracing.

5. **WASHBOARD COURSE.** The washboard test was conducted for informational purposes only. The rear header (door end) separated from the trailer floor. This allowed the entire load to move toward the trailer door. One pallet of the PA116 Containers fell from the trailer.

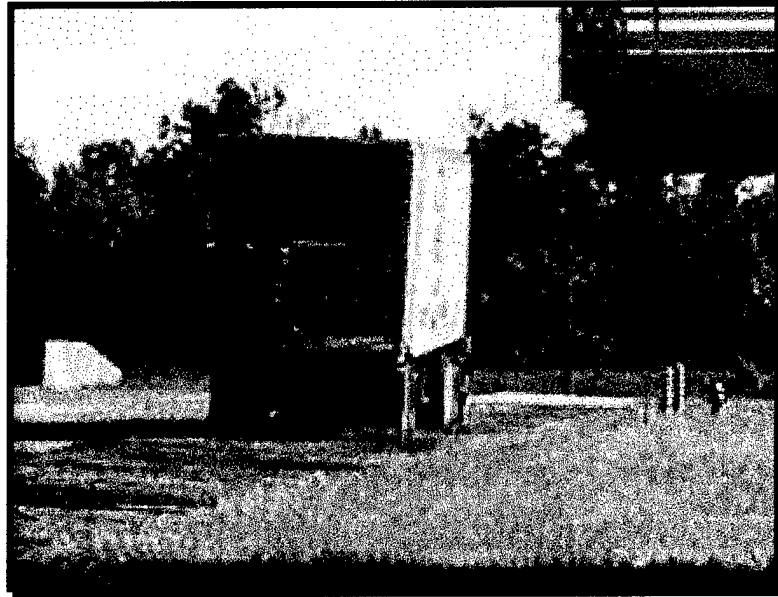

Photo 14. PA116 Pallet Falling from the Trailer During the Washboard Test



Photo 15. PA116 Container Pallet After Dropping From the Trailer During Washboard Course

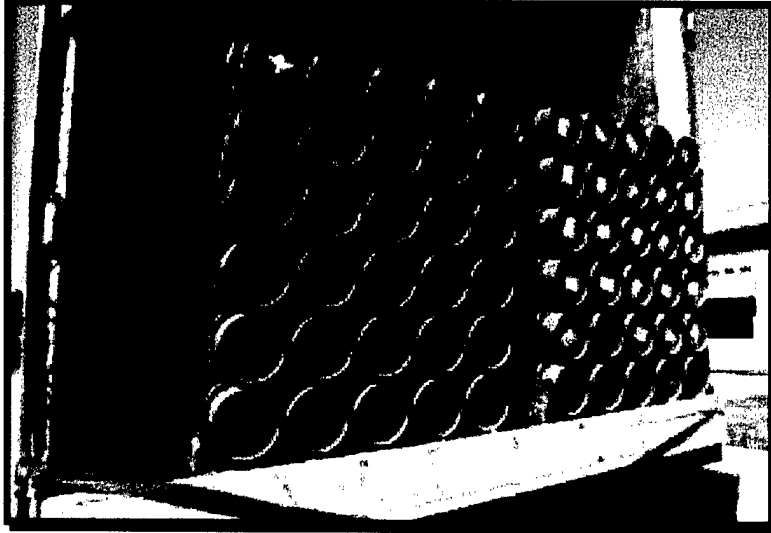

Photo 16. Header that Pulled From the Trailer Floor During Washboard Course

B. CONCLUSION: The nail pattern successfully completed the required testing. The failure that occurred was during the optional washboard testing, and, therefore, did not constitute a test failure.

5.5 Testing Date: 13 August 2002

Payload: PA116 Metal Containers on Wood Pallets

Payload Weight: 39,220 Pounds

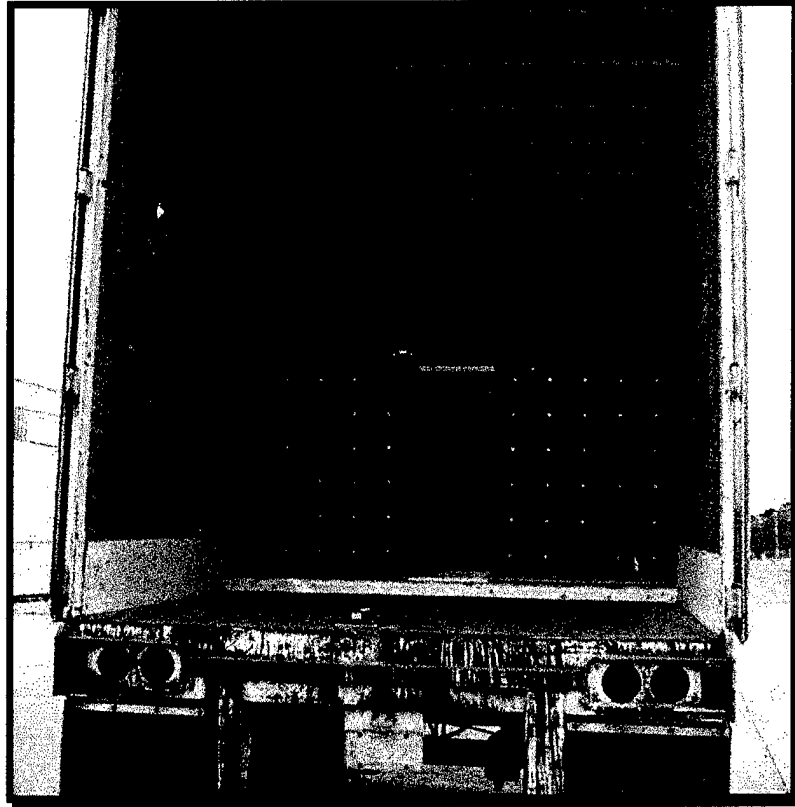

Photo 17. PA116 Metal Containers on Wood Pallets Test Load

A. ON/OFF ROAD TEST.

1. HAZARD COURSE.

Pass No.	Elapsed Time	Avg. Velocity (MPH)
1	26 Seconds	6
2	29 Seconds	5

Figure 7.

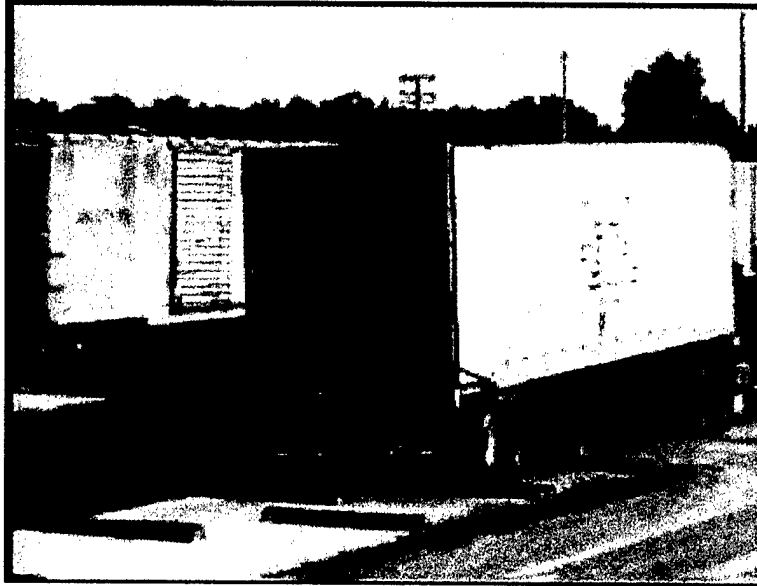

Photo 18. Washboard Course Testing of PA116 Containers on Wood Pallets

Remarks:

1. Figure 7 lists the average speed of the test load through the Hazard Course.
2. Inspection following Pass #2 revealed that the load moved toward the rear of the trailer 1.5 inches. The movement was caused by shifting of the pallet contents. The blocking and bracing was not damaged.

2. **ROAD TRIP:** Inspection revealed no excessive movement of the payload, damage to the trailer, or blocking and bracing.

3. **PANIC STOPS:**

Remarks:

1. Inspection following the forward 5 MPH stop revealed that the load moved forward 1.5 inches.
2. Inspection following the reverse 5 MPH revealed the load moved toward the rear of the trailer 1.5 inches. The movement was caused by shifting of the pallet contents. The blocking and bracing was not damaged.

4. HAZARD COURSE:

Pass No.	Elapsed Time	Avg. Velocity (MPH)
3	28 Seconds	6
4	29 Seconds	5

Figure 8.

Remarks:

1. Figure 8 lists the average speeds of the test load through the Hazard Course.
2. Inspection following Pass #3 revealed that the load moved 0.5 inches forward.
3. Inspection following Passes #3 and #4 revealed no excessive movement of the payload, damage to the trailer or blocking and bracing.

5. WASHBOARD COURSE: The washboard test was conducted for informational purposes only. Inspection following the completion of the test revealed that the load had moved toward the rear of the trailer 2.6 inches.



Photo 19. Washboard Course Testing of the PA116 Containers on Wood Pallets

B. CONCLUSION: The nail pattern successfully completed the required testing.

5.6 Testing Date: 16 August 2002

Payload: 155MM Separate Loading Projectiles

Payload Weight: 42,480 Pounds

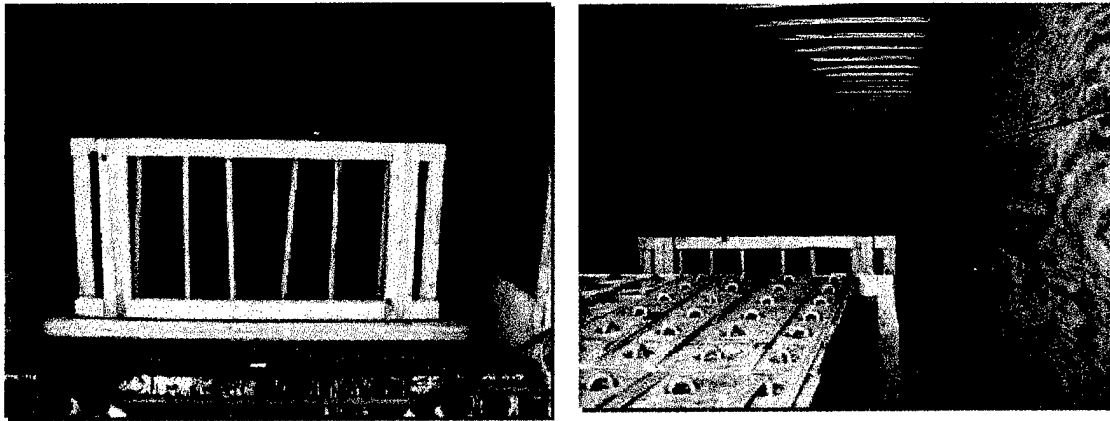

Photos 20. and 21. 155MM Separate Loading Projectiles Test Load

A. ON/OFF ROAD TEST.

1. HAZARD COURSE.

Pass No.	Elapsed Time	Avg. Velocity (MPH)
1	34 Seconds	5
2	32 Seconds	5

Figure 9.

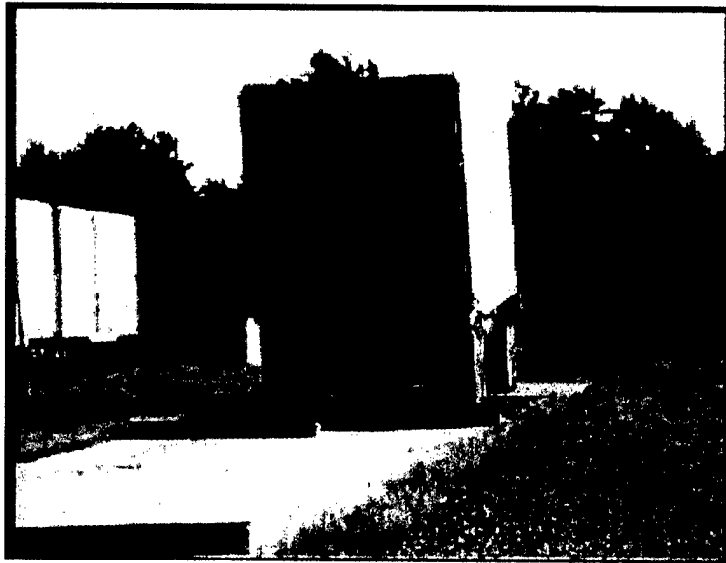

Photo 22. Hazard Course Testing of the 155MM SLP Payload

Remarks:

1. Figure 9 lists the average speed of the test load through the Hazard Course.
2. Inspection following Pass #2 revealed that the front load moved 0.25 inches toward the front of the trailer.
3. Inspection following Passes #1 and #2 revealed no excessive movement of the payload, damage to the trailer or blocking and bracing.

2. **ROAD TRIP:** Inspection revealed no excessive movement of the payload, damage to the trailer or blocking and bracing.

3. **PANIC STOPS:** Inspection revealed no excessive movement of the payload, damage to the trailer or blocking and bracing.

4. **HAZARD COURSE:**

Pass No.	Elapsed Time	Avg. Velocity (MPH)
3	30 Seconds	5
4	28 Seconds	6

Figure 10.

Remarks:

1. Figure 10 lists the average speeds of the test load through the Hazard Course.
2. During Pass #4 the payload bounced onto the rear header at the trailer door. However, the pallet did reseat prior to the completion of the pass.
3. Inspection following Passes #3 and #4 revealed no excessive movement of the payload, damage to the trailer or blocking and bracing.

5. WASHBOARD COURSE.

Remarks:

1. The washboard test was conducted for informational purposes only.
2. The load-bearing gate, at the trailer door was damaged. During transport over the hazard course the passenger side bay of 155MM SLPs bounced onto the end blocking. The load moved toward the door of the trailer and damaged the gate.
3. The end blocking separated from the floor 0.3 inches at the door end of the trailer.
4. The end blocking (closed end) of the second bay of 155MM SLPs moved forward 0.25 inches due to the nails bending.
5. The load bearing gate (door end) fill piece of the second bay of 155MM SLPs disengaged.



Photo 23. Washboard Course Testing of the 155MM SLP Payload

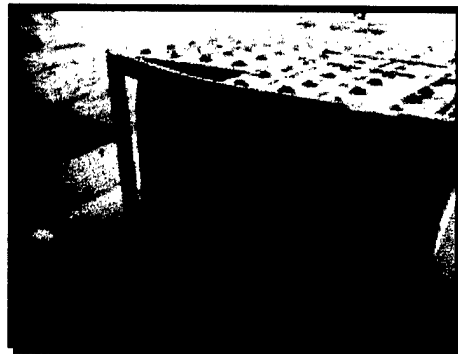
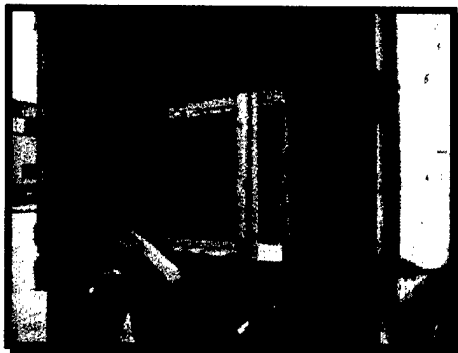

Photos 24. and 25. Damaged Load Bearing Gates

B. CONCLUSION: The nail pattern successfully completed the required testing.

5.7 Testing Date: 22-26 August 2002

Payload: PA116 Metal Containers on Metal Pallets

Payload Weight: 39,460 Pounds

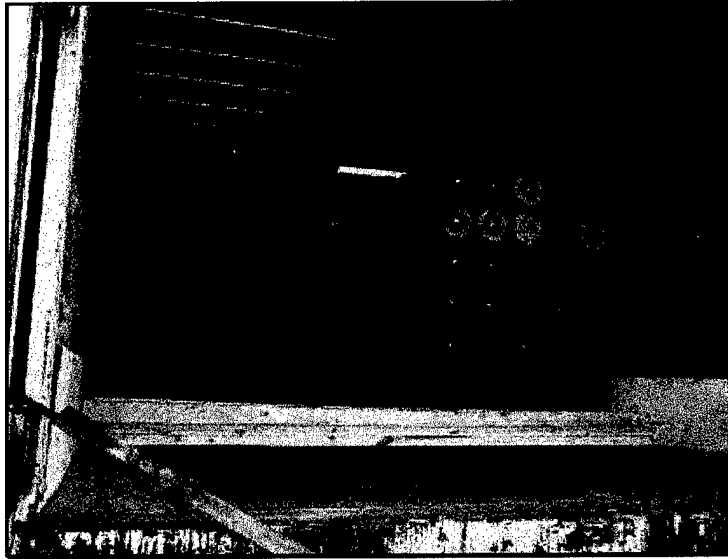

Photo 26. PA116 Metal Containers on Metal Pallets Test Load

A. ON/OFF ROAD TEST.

1. HAZARD COURSE.

Pass No.	Elapsed Time	Avg. Velocity (MPH)
1	28 Seconds	6
2	29 Seconds	5

Figure 11.

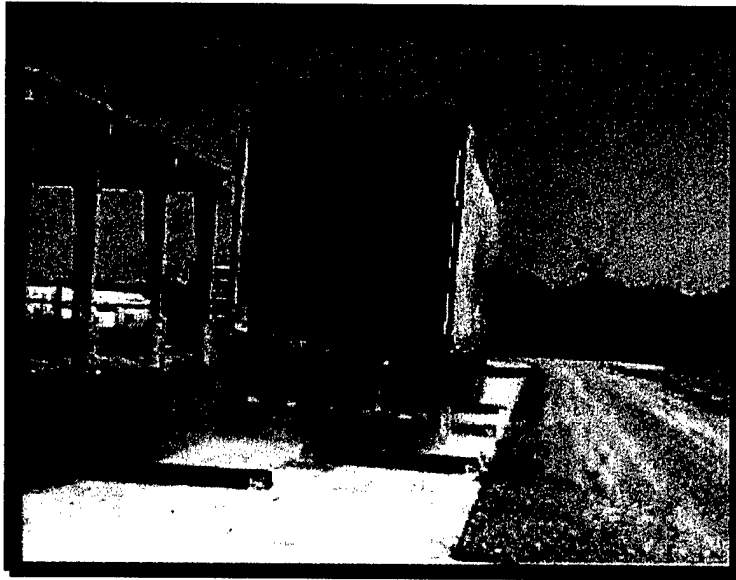

Photo 27. Washboard Course Testing of the PA116 Containers on Metal Pallets

Remarks:

1. Figure 11 lists the average speed of the test load through the Hazard Course.
2. Inspection following Passes #1 and #2 revealed no excessive movement of the payload, damage to the trailer or blocking and bracing.

2. ROAD TRIP:

Remarks:

1. The Road Trip was conducted between the Road Hazard Course Passes #2 and #3.
2. Inspection following the completion of the Road Trip revealed that the top board of the rear header at the door end on the passenger side had separated 0.25 inches from the board below.
3. Inspection revealed no excessive movement of the payload, damage to the trailer or the blocking and bracing.

3. PANIC STOPS:

Remarks:

1. The panic stops were conducted during the Road Trip.
2. The reverse panic stop was repeated due to equipment problems.
3. Inspection revealed no excessive movement of the payload, damage to the trailer or blocking and bracing.

4. HAZARD COURSE:

Pass No.	Elapsed Time	Avg. Velocity (MPH)
3	29 Seconds	5
4	28 Seconds	6

Figure 12.

Remarks:

1. Figure 12 lists the average speeds of the test load through the Hazard Course.
2. Inspection following Pass #3 revealed that the load (12 pallet bay) moved 1.25 inches on the driver's side and 0.75 inches on the passenger's side toward the rear of the trailer.
3. Inspection following Pass #3 revealed that the top of the rear header at the door end on the passenger side had separated an additional 0.38 inches from the board below.
4. Inspection following completion of Passes #3 and #4 revealed no excessive movement of the payload, damage to the trailer or the blocking and bracing.

5. WASHBOARD COURSE:

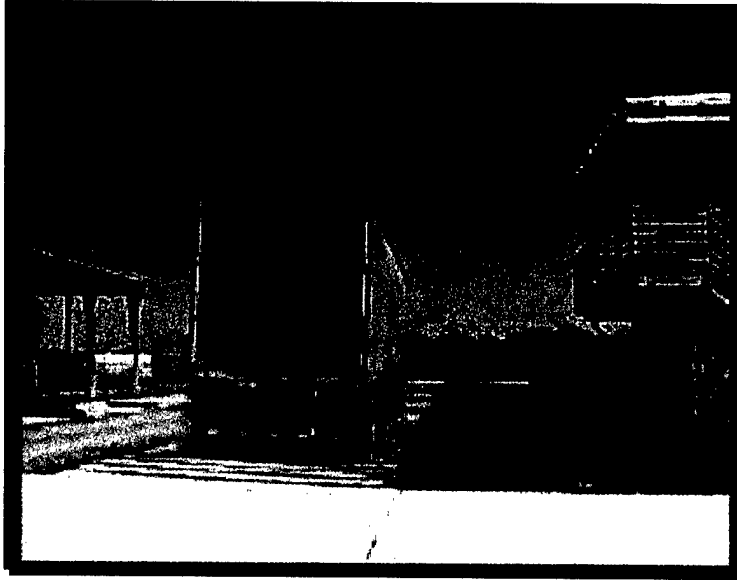

Photo 28. Washboard Course Testing of the PA116 Containers on Metal Pallets

Remarks:

1. The washboard test was conducted for informational purposes only.
2. Inspection following completion of the washboard course revealed that the top of the rear header at the door end on the passenger side had separated an additional 0.38 inches from the board below. Total separation was now 1.0 inch.
3. Inspection following completion of the washboard course revealed no excessive movement of the payload, damage to the trailer or the blocking and bracing.

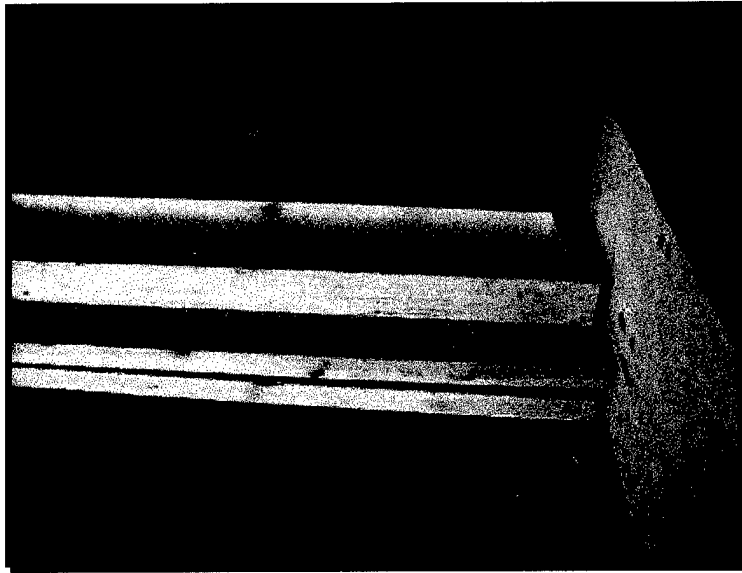

Photo 29. Separation of the Rear Header Board

B. CONCLUSION: The nail pattern successfully completed the required testing. However, during testing the top board of the rear header at the door end passenger side did separate a total of 1 inch from the header bottom.

PART 6 – ACCELEROMETER DATA

The accelerometers were located on the trailer floor and on the payload throughout testing. The axial orientation of the accelerometers is as follows: Also following are the graphic depictions of each of the railcar impacts, hazard course, road course, and washboard course. The axial orientation of the accelerometers is as follows:



r - resultant vector x – longitudinal y –lateral z – vertical

A table depicting the identification and location of the graphic illustrations is below:

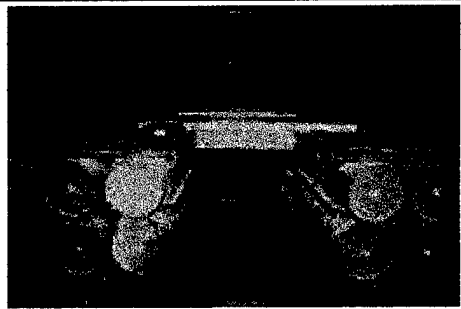
NAILED FLOOR-LINE BLOCKING METHODS	
PAYLOAD: PA116 ON WOOD PALLETS	PAGE
Hazard Course – Pass #1	6-2
Hazard Course – Pass #2	6-2
Road Trip	6-
Hazard Course – Pass #3	6-3
Hazard Course – Pass #4	6-3
Washboard Course	No data

	
Photo 20. PA116 on Wood Pallets Trailer Floor Sensor Location	Photo 21. PA116 on Wood Pallets Payload Sensor Location

NAILED FLOOR-LINE BLOCKING METHODS	
PAYLOAD: 155MM SEPARATE LOADING PROJECTILES	PAGE
Hazard Course – Pass #1	6-2
Hazard Course – Pass #2	6-2
Road Trip	6-
Hazard Course – Pass #3	6-3
Hazard Course – Pass #4	6-3
Washboard Course	No data

	
<p>Photo 22. 155MM SLP on Traller Floor Sensor Location</p>	<p>Photo 23. 155MM SLP on Payload Sensor Location</p>

NAILED FLOOR-LINE BLOCKING METHODS	
PAYLOAD: PA116 ON METAL PALLETS	PAGE
Hazard Course – Pass #1	6-2
Hazard Course – Pass #2	6-2
Road Trip	6-
Hazard Course – Pass #3	6-3
Hazard Course – Pass #4	6-3
Washboard Course	No data

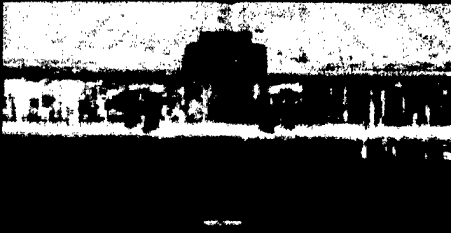
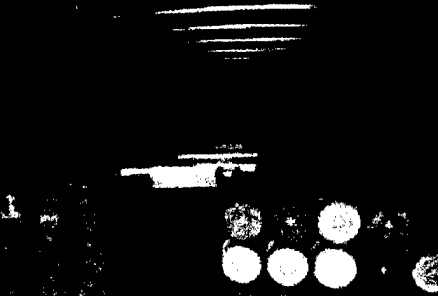
	
<p>Photo 24. PA116 on Metal Pallets Traller Floor Sensor Location</p>	<p>Photo 25. PA116 on Metal Pallets Payload Location</p>

Multiple Wave View: PA116 on Wood Pallets - Hazard Passes 1 & 2, EDR3 #0186 Acceleration

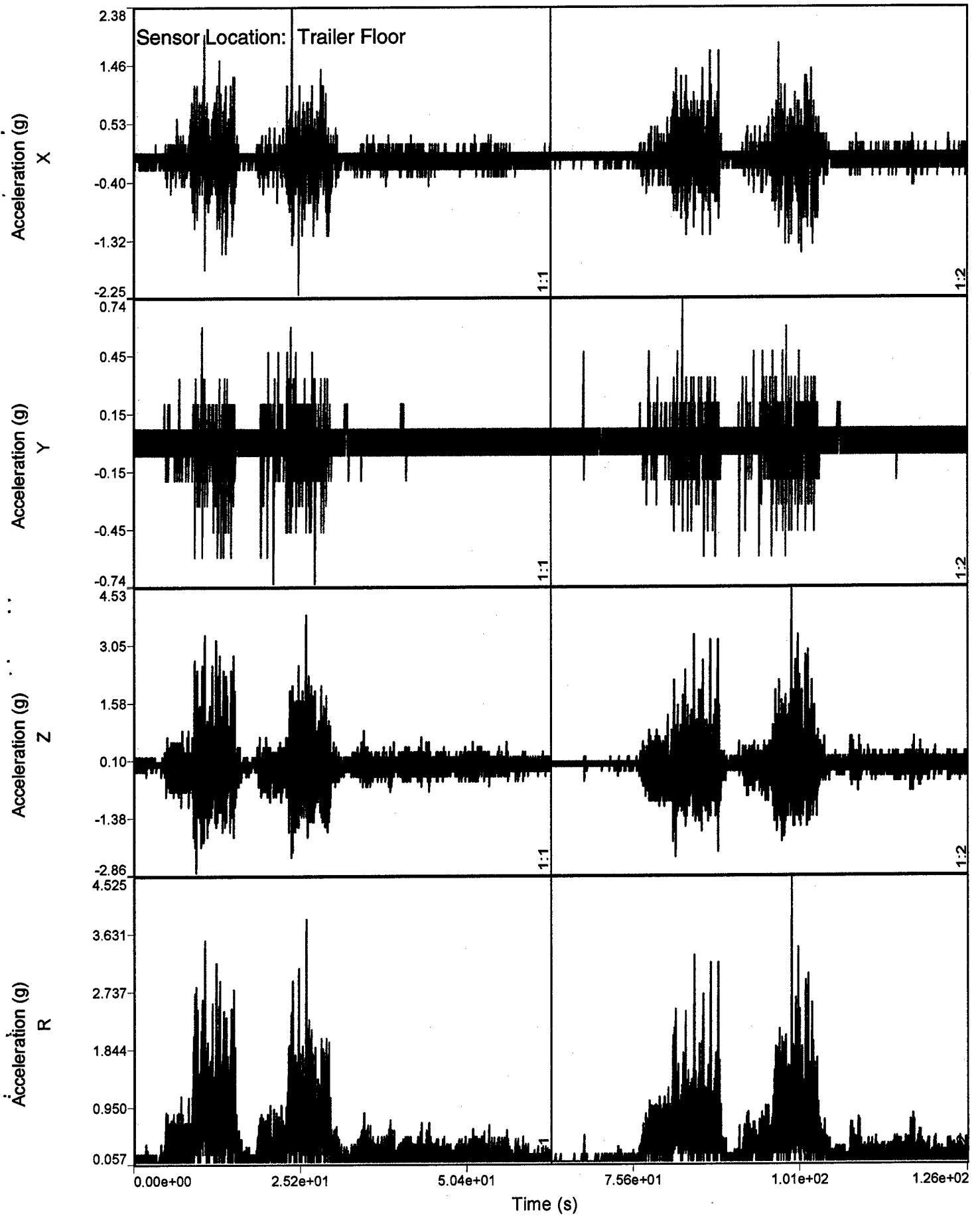

Multiple Wave View: PA116 on Wood Pallets - Hazard Passes 1 & 2, EDR3 #0185 Acceleration

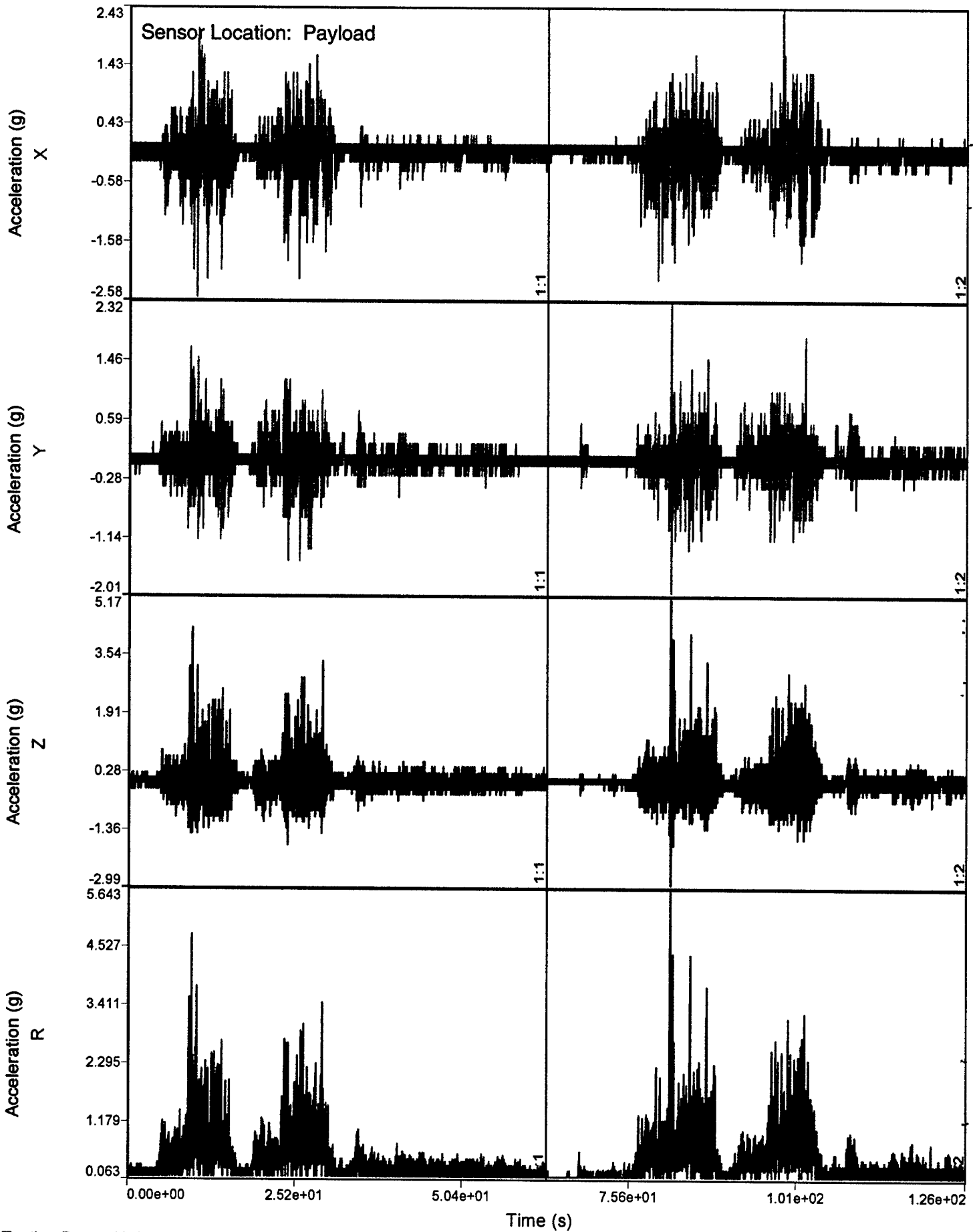

Testing Date: 13 August 2002

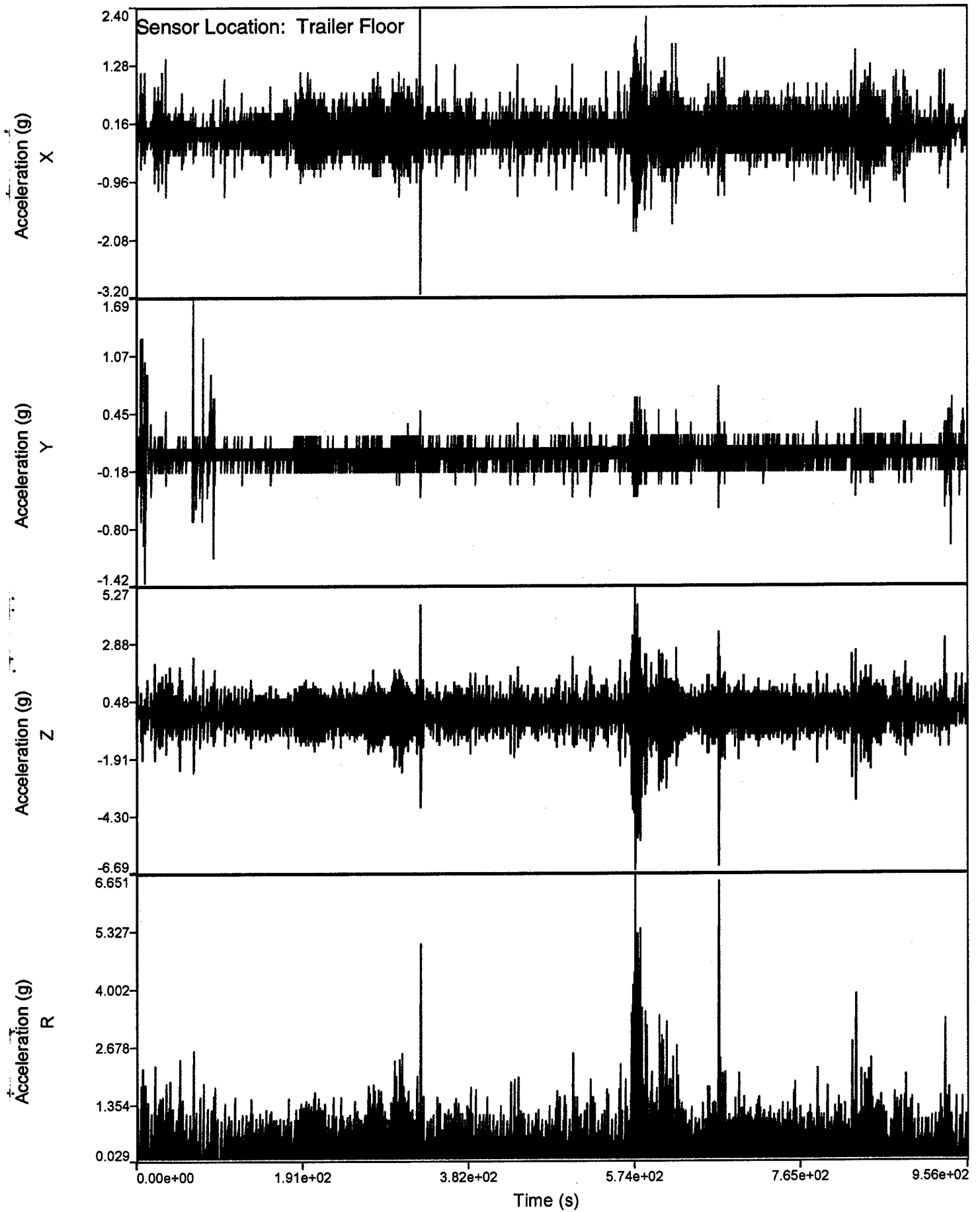

Testing Date: 13 August 2002

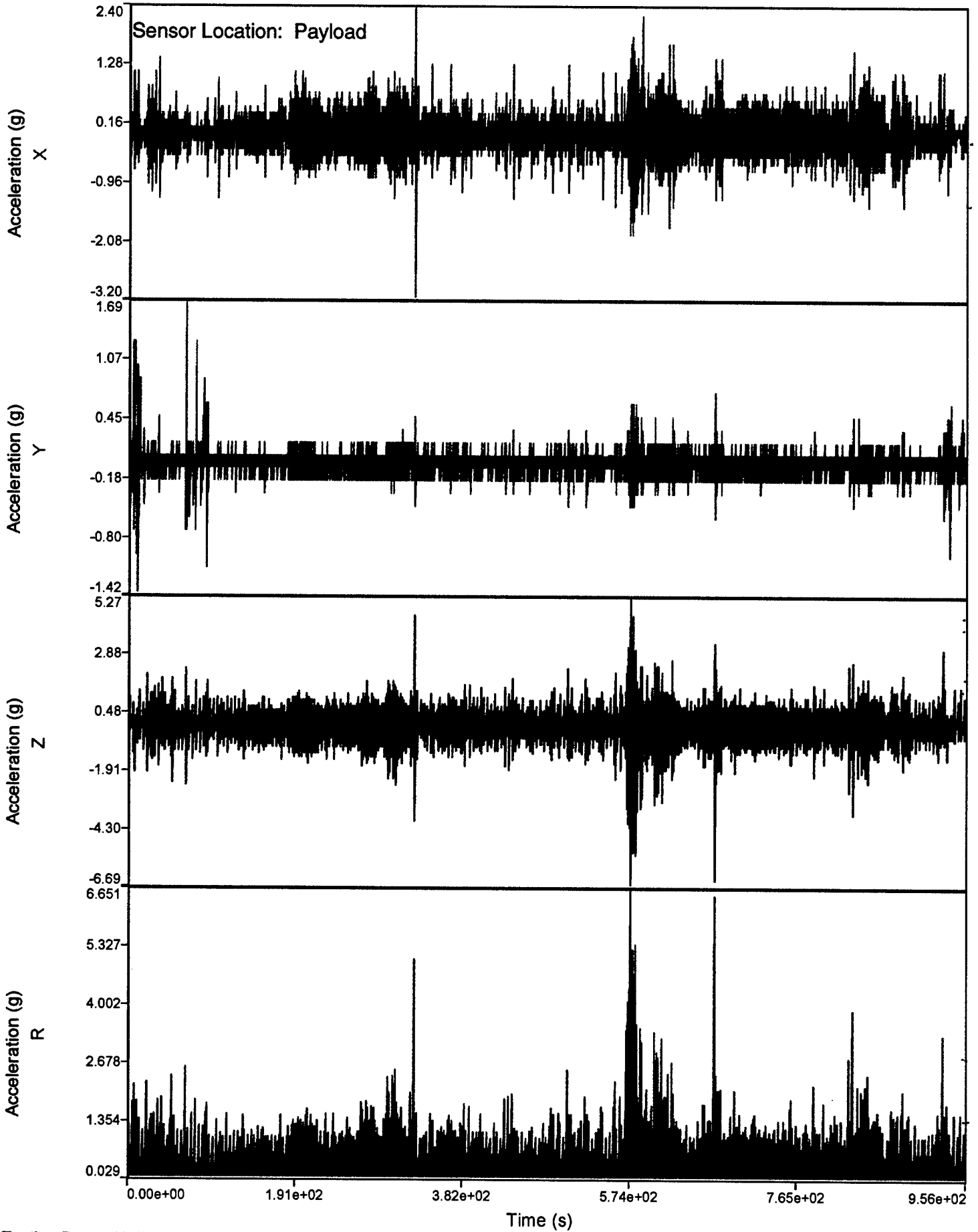

Testing Date: 13 August 2002

Multiple Wave View: PA116 on Wood Pallets - Hazard Passes 3 & 4, EDR3 #0186 Acceleration

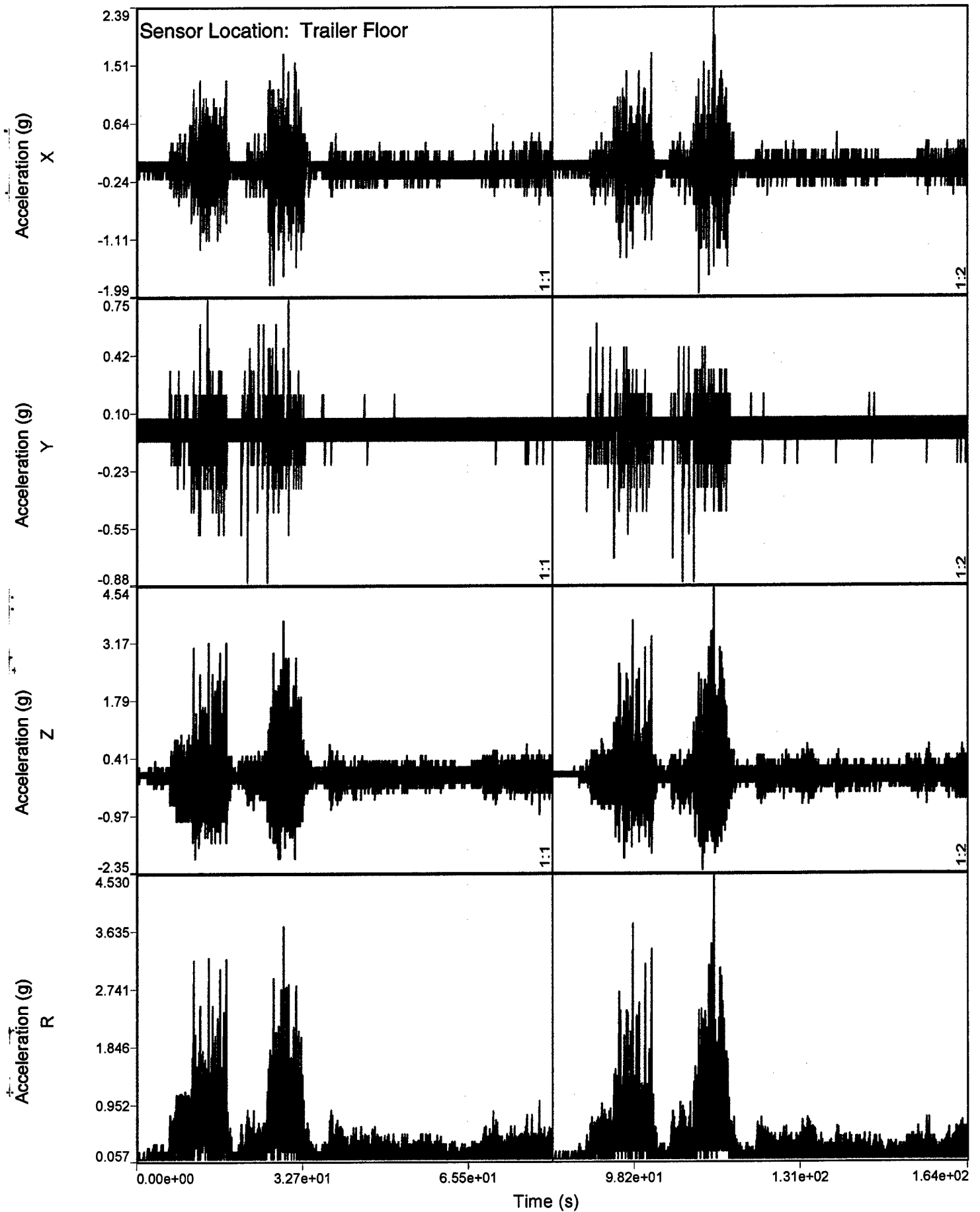

Testing Date: 13 August 2002

Multiple Wave View: PA116 on Wood Pallets - Hazard Passes 3 & 4, EDR3 #0185 Acceleration

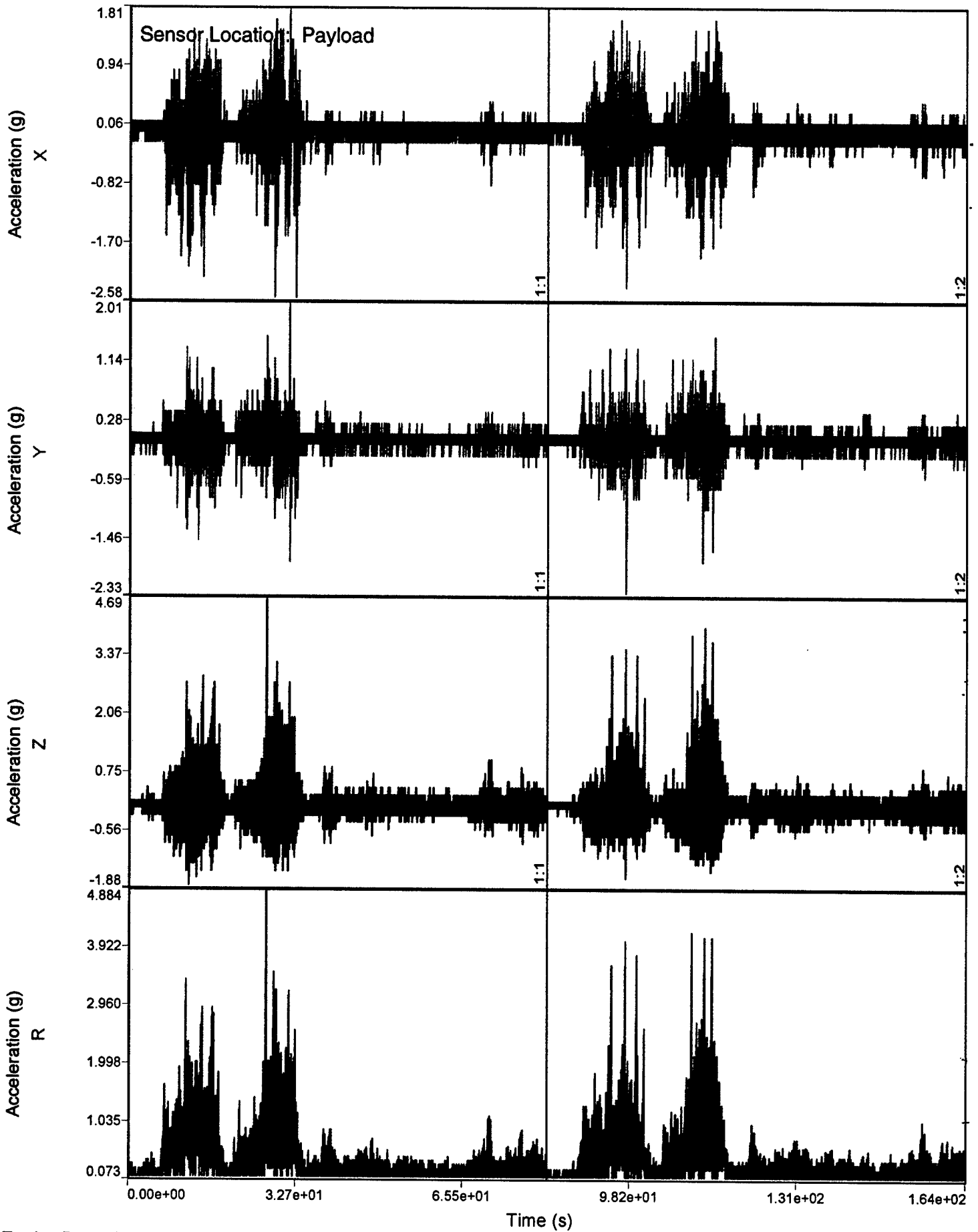

Testing Date: 13 August 2002

Multiple Wave View: PA116 on Wood Pallets - Washboard Course, EDR3 #0186 Acceleration

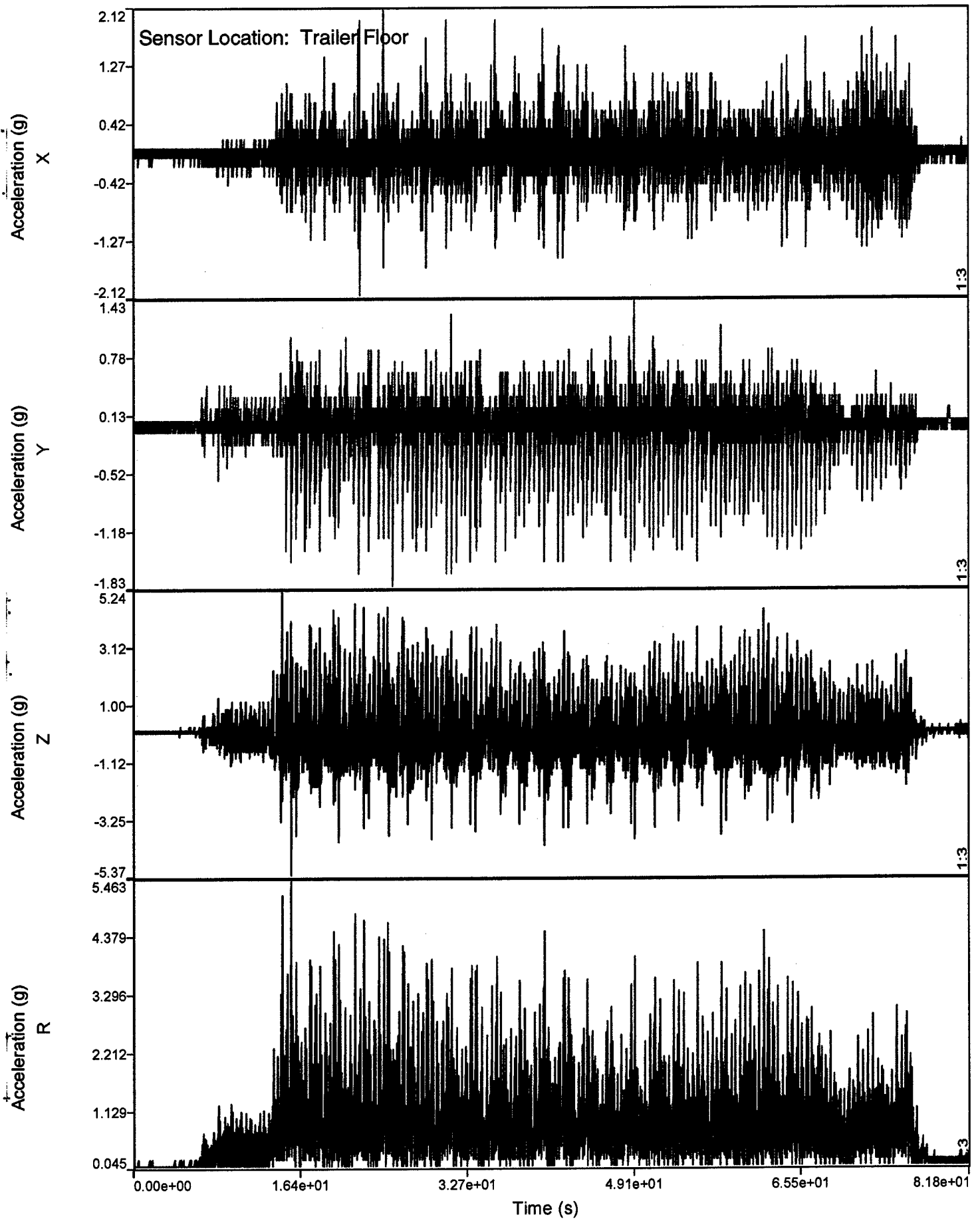

Testing Date: 13 August 2002

Multiple Wave View: PA116 on Wood Pallets - Washboard Course, EDR3 #0185 Acceleration

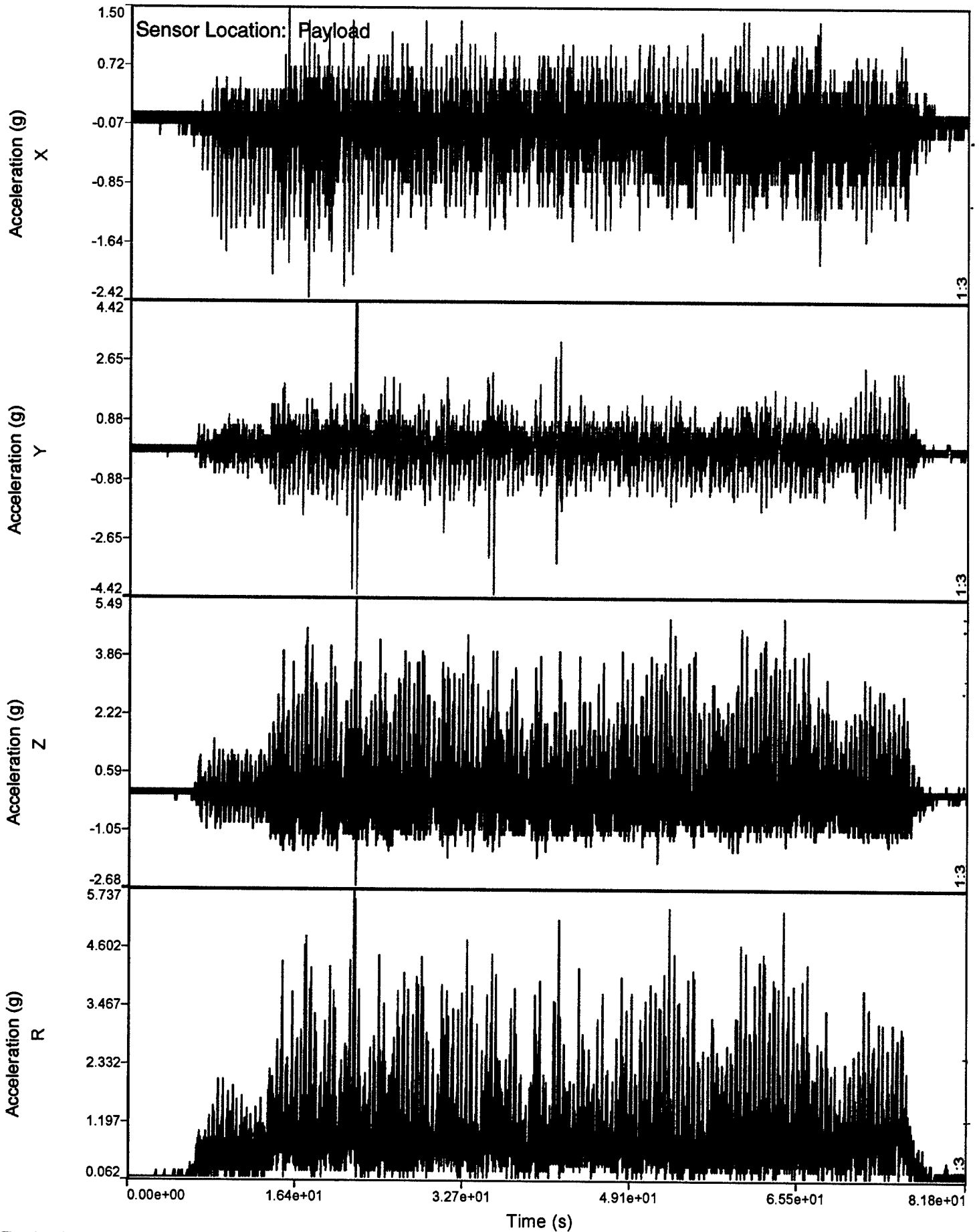

Testing Date: 13 August 2002

Multiple Wave View: 155MM SLP - Hazard Passes 1 and 2, EDR3 #0185 Acceleration

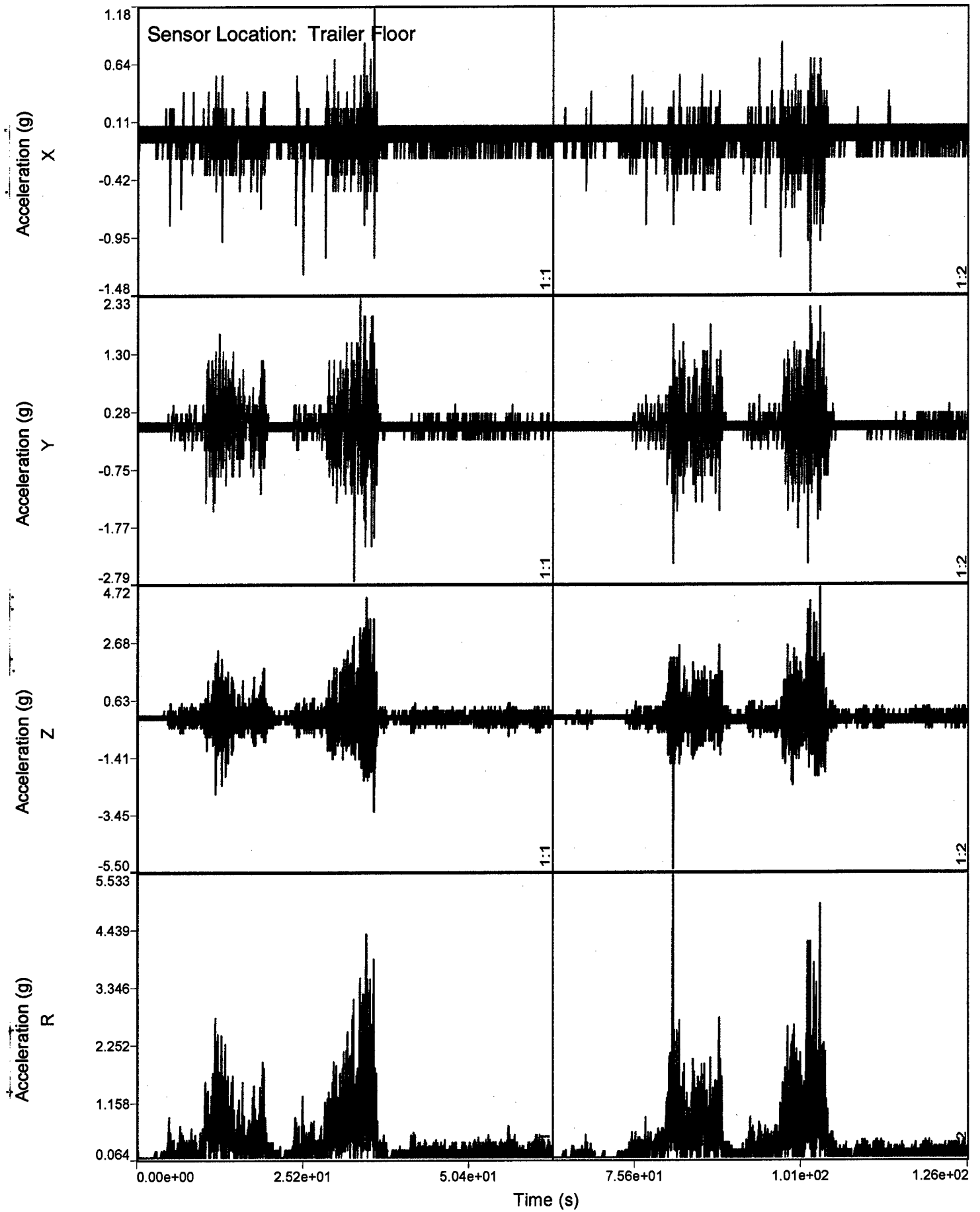

Testing Date: 16 August 2002

Multiple Wave View: 155MM SLP - Hazard Passes 1 & 2, EDR3 #0185 Acceleration

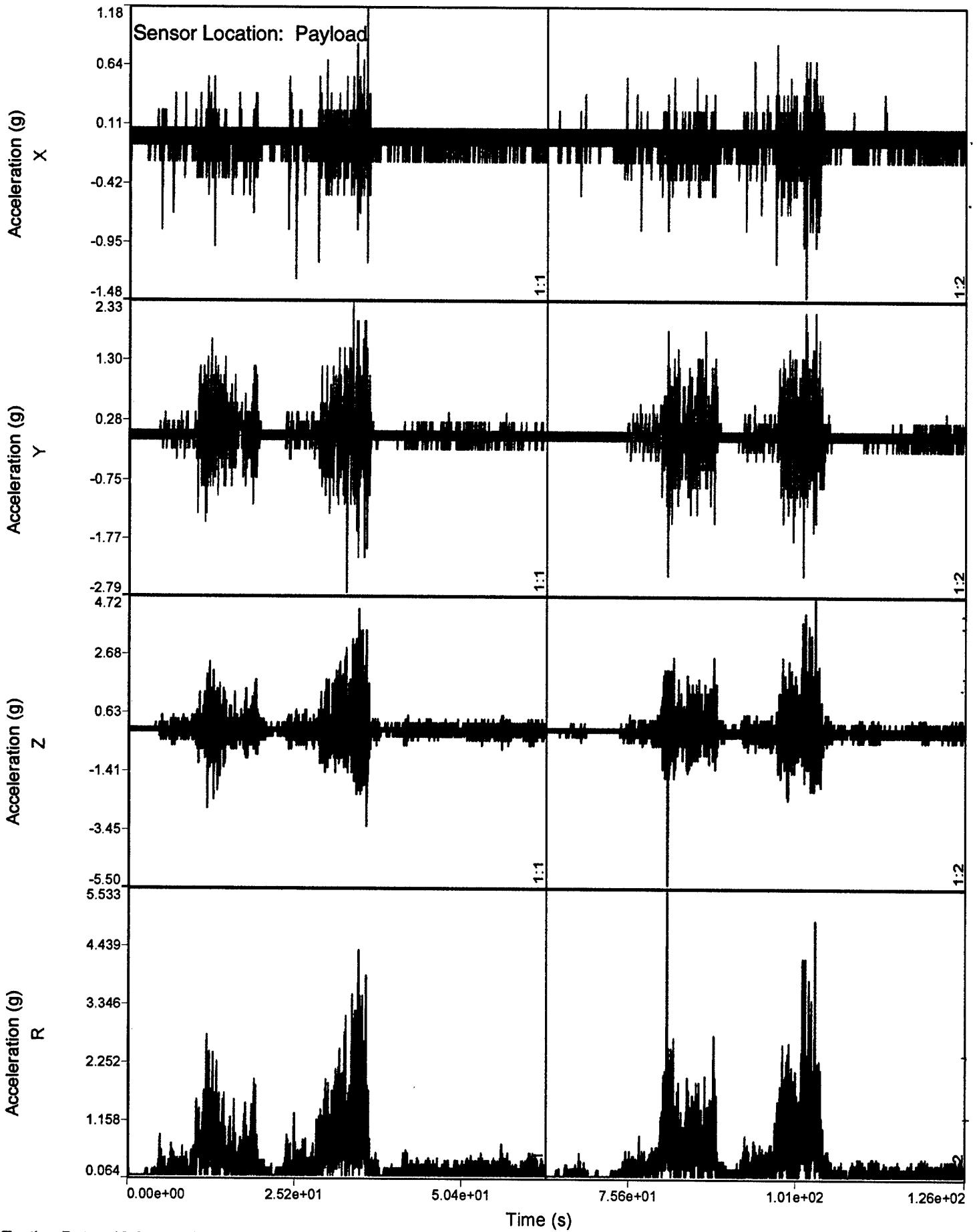

Testing Date: 16 August 2002

Time (s)

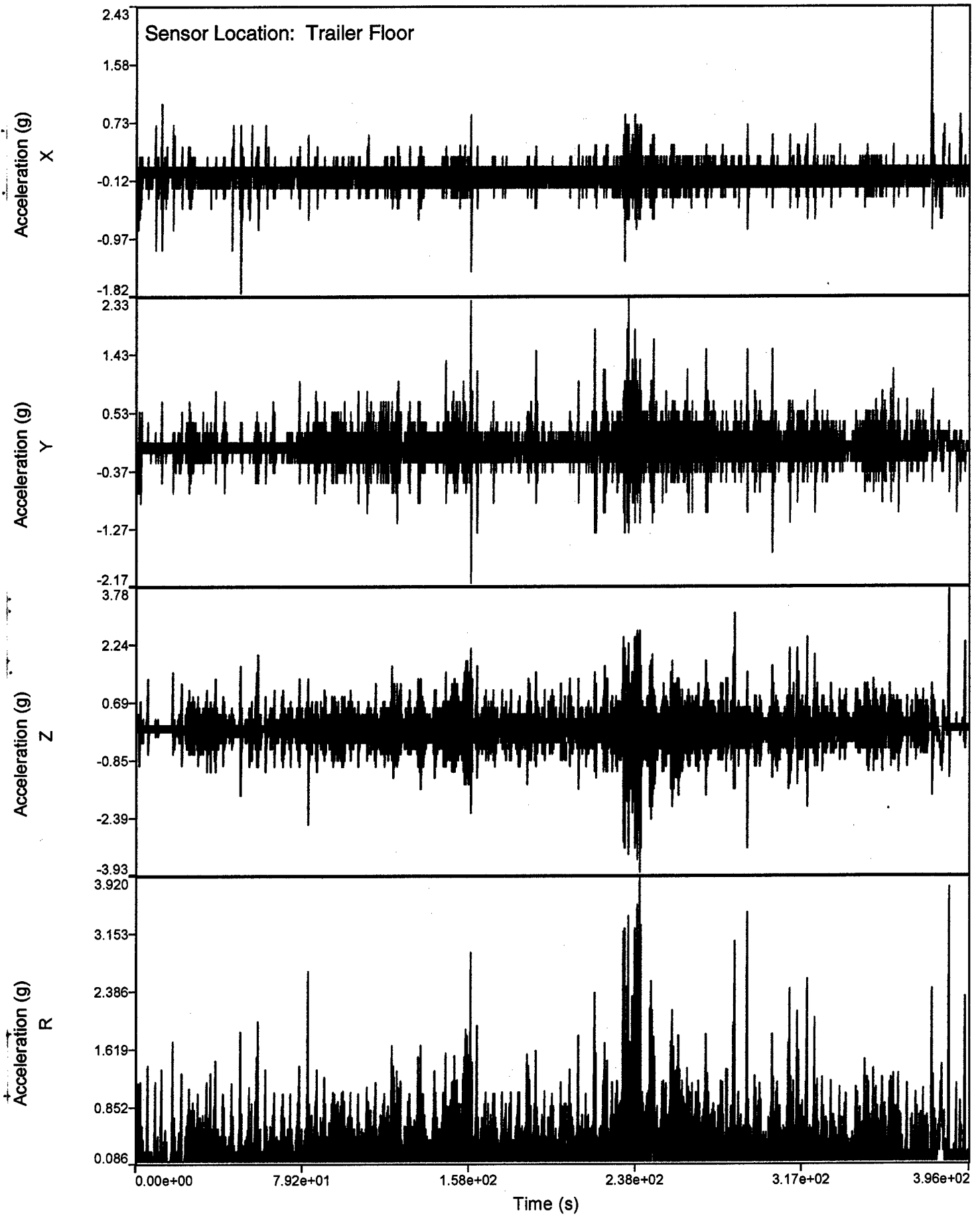

Testing Date: 16 August 2002

Multiple Wave View: 155MM SLP, 30 Mile Road Course, EDR3 #0186 Acceleration

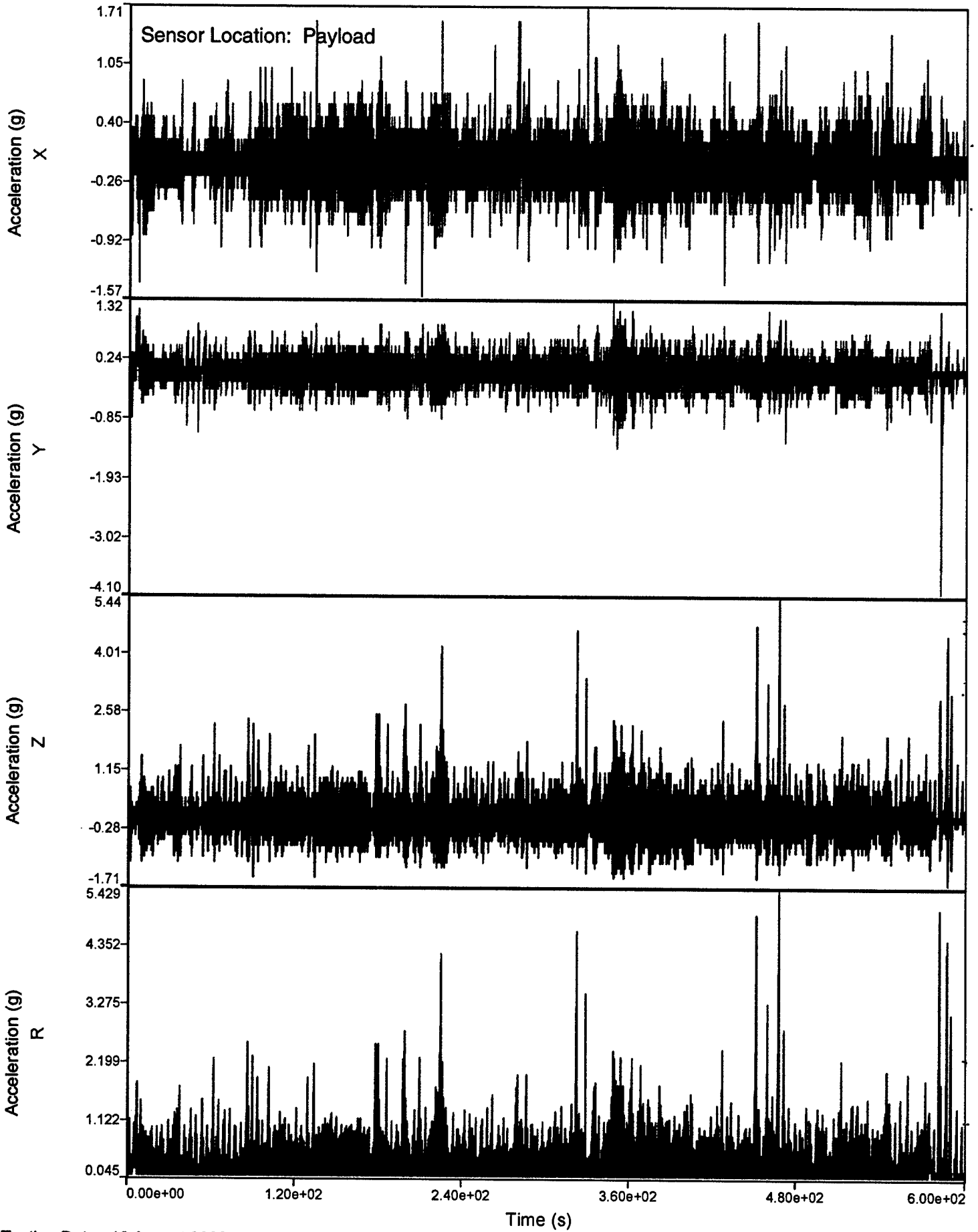

Testing Date: 16 August 2002

Multiple Wave View: 155MM SLP - Hazard Passes 3 & 4, EDR3 #0185 Acceleration

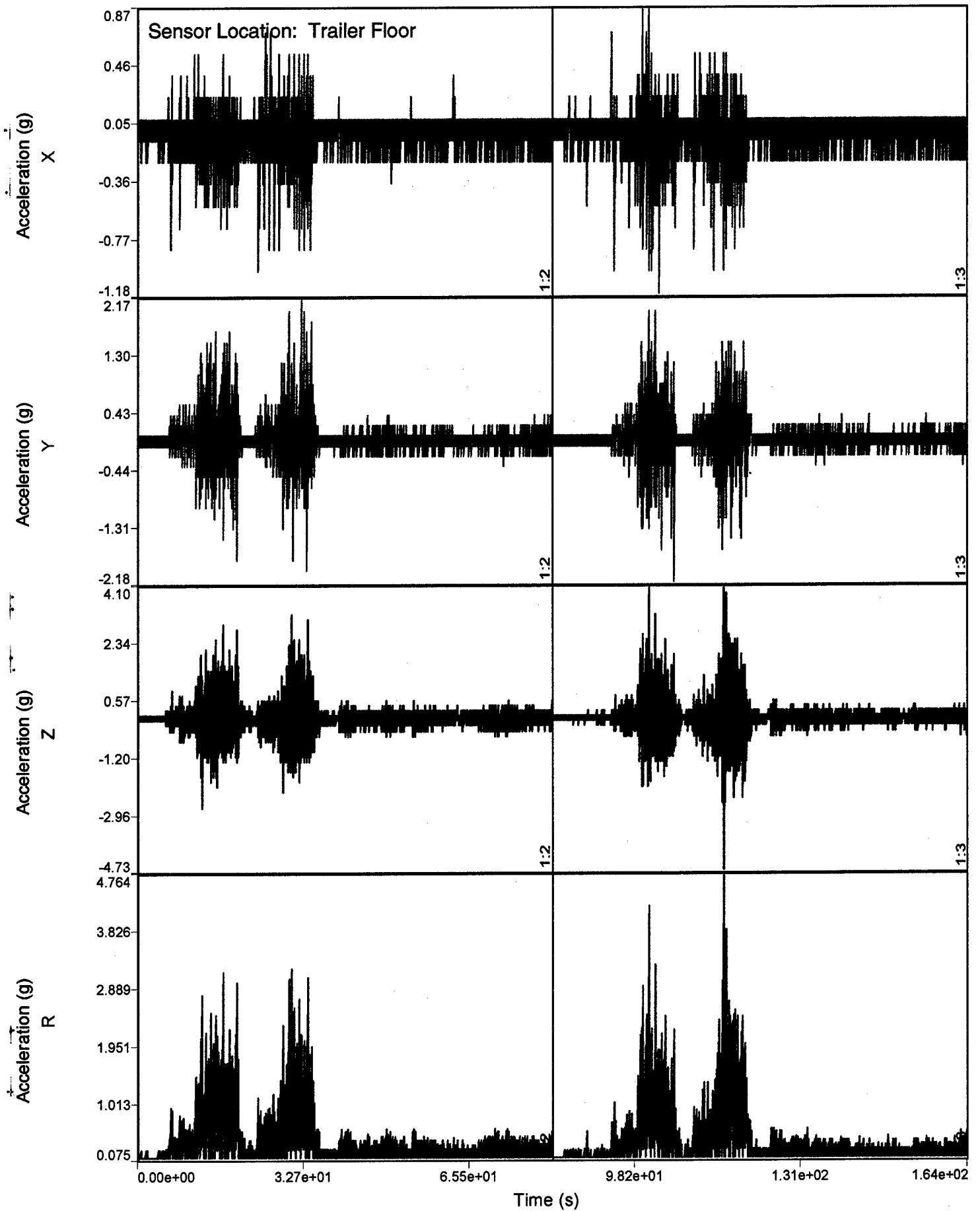

Testing Date: 16 August 2002

Multiple Wave View: 155MM SLP - Hazard Passes 3 & 4, EDR3 #0186 Acceleration

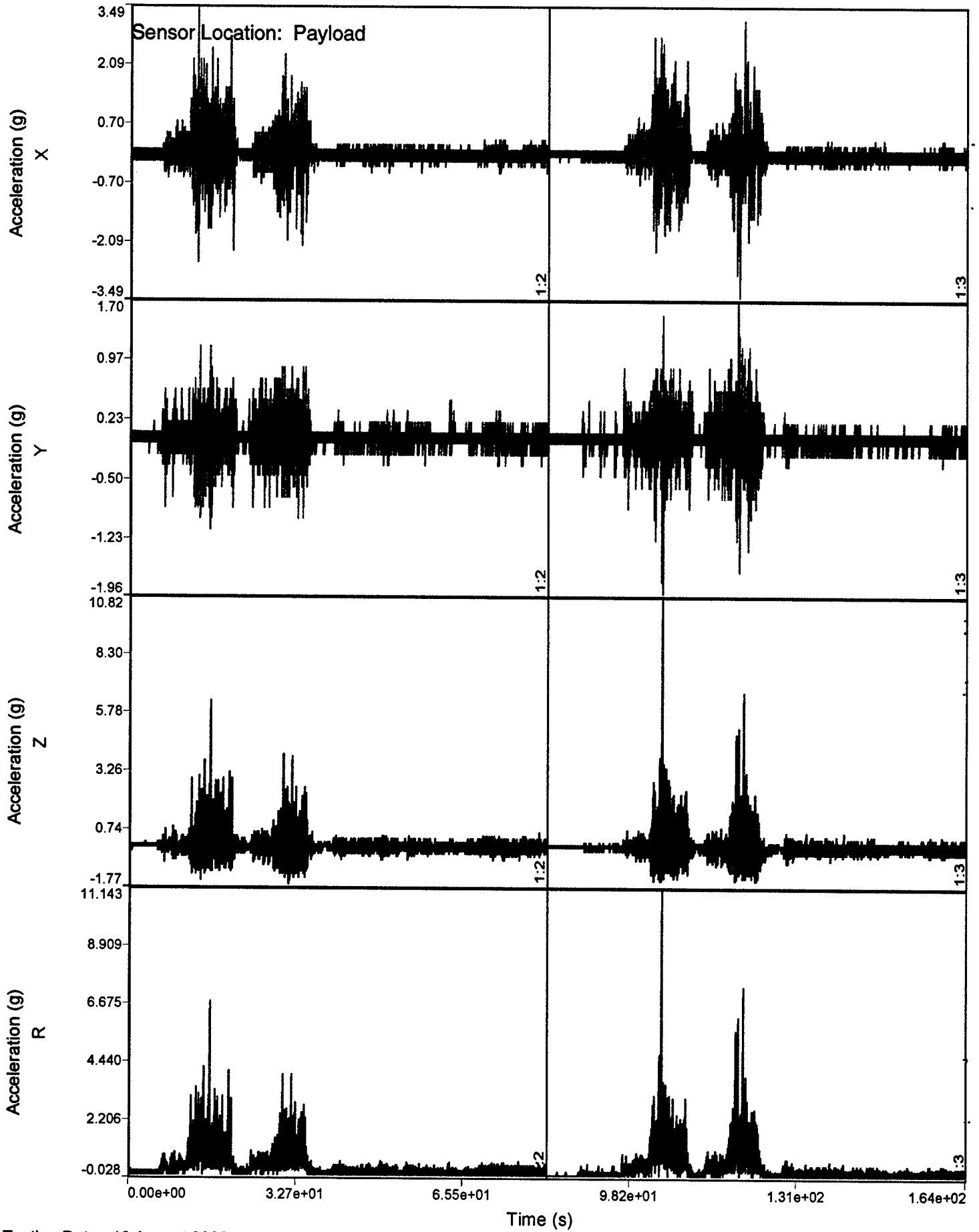

Testing Date: 16 August 2002

Multiple Wave View: 155MM SLP, Washboard Course, EDR3 #0185 Acceleration

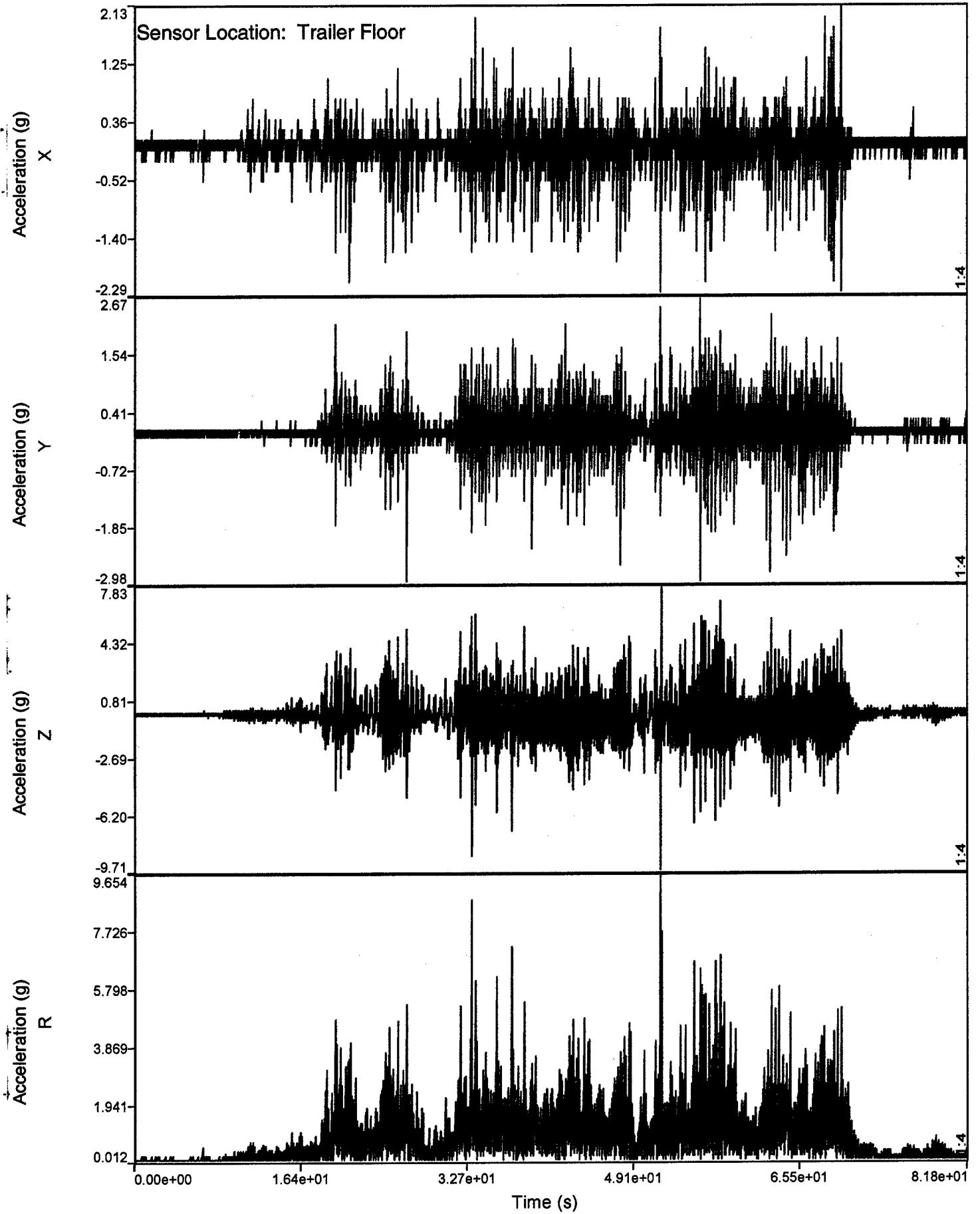

Testing Date: 16 August 2002

Multiple Wave View: 155MM SLP - Washboard Course, EDR3 #0186 Acceleration

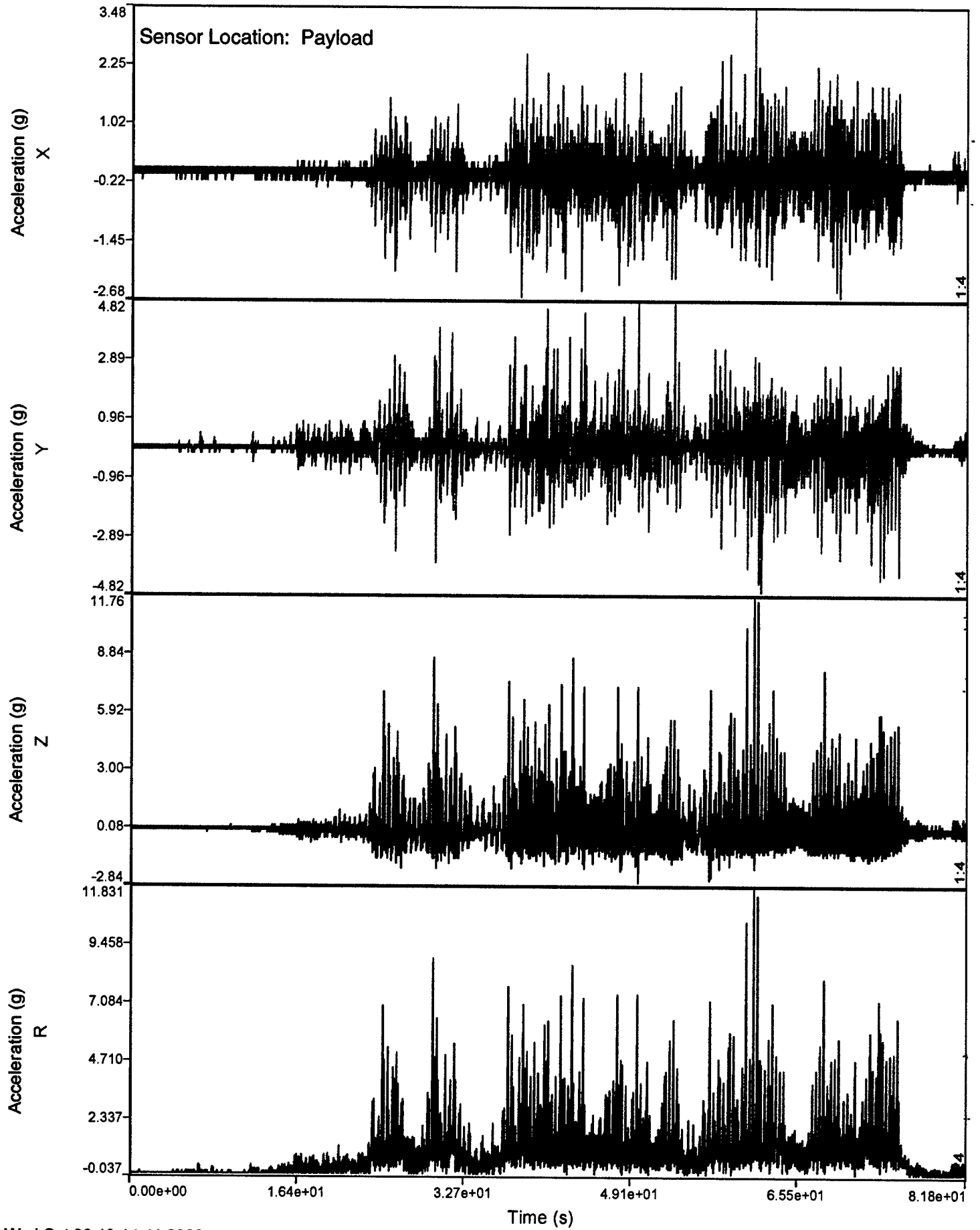

Multiple Wave View: PA116 on Metal Pallets - Hazard Passes 1 & 2, EDR3 #0185 Acceleration

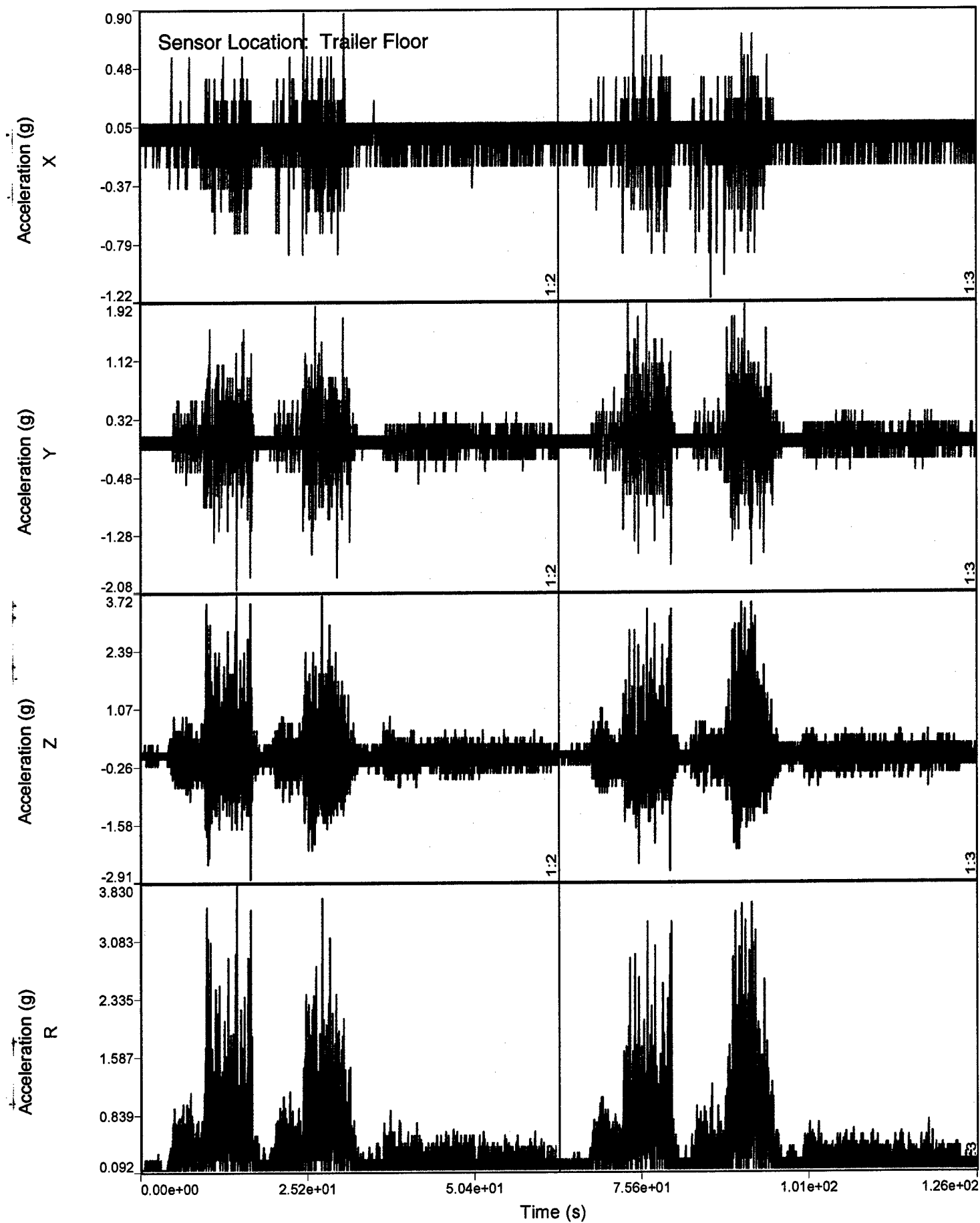

Testing Date: 22-26 August 2002

Multiple Wave View: PA116 on Metal Pallets - Hazard Passes 1 & 2, EDR3 #0186 Acceleration

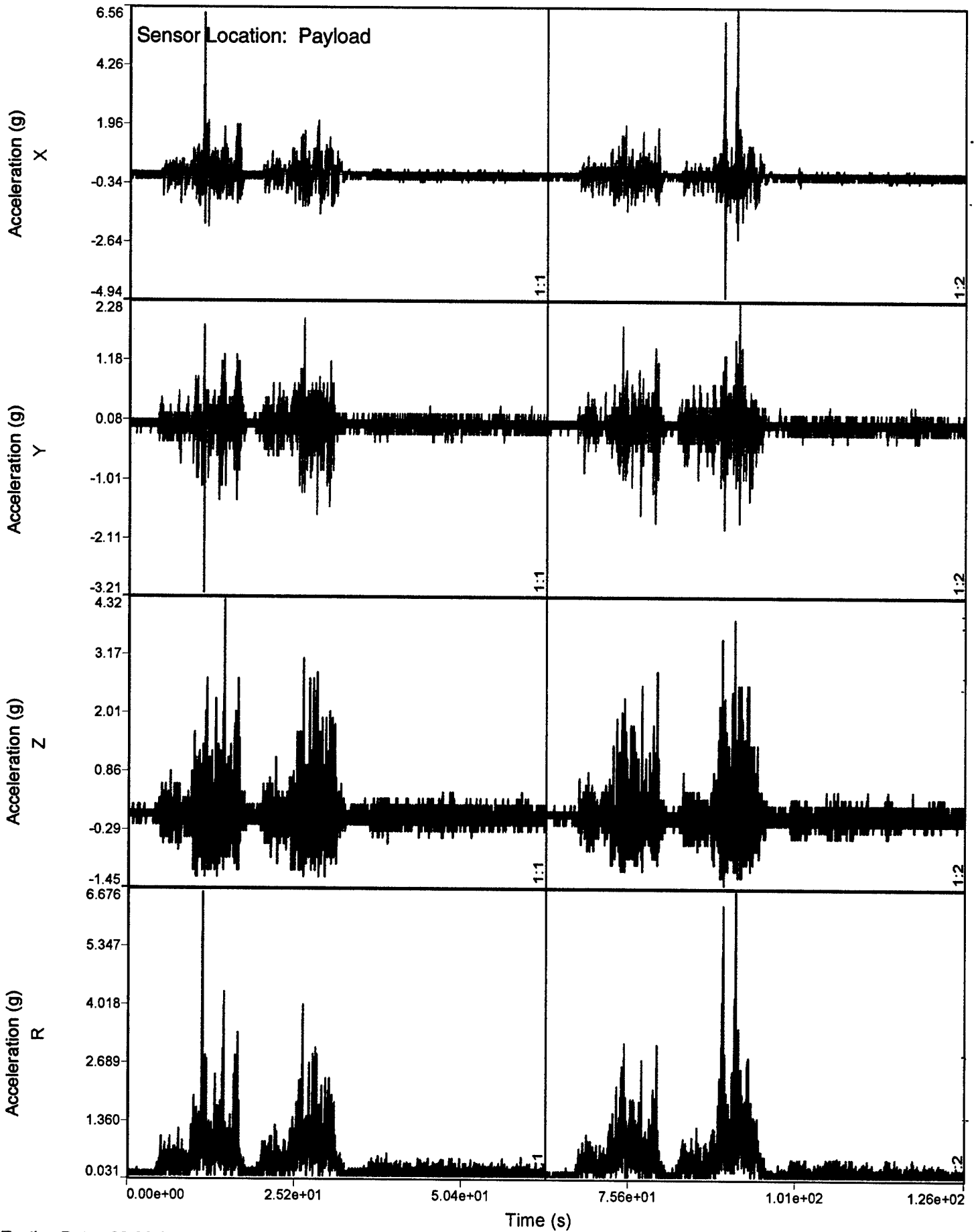

Testing Date: 22-26 August 2002

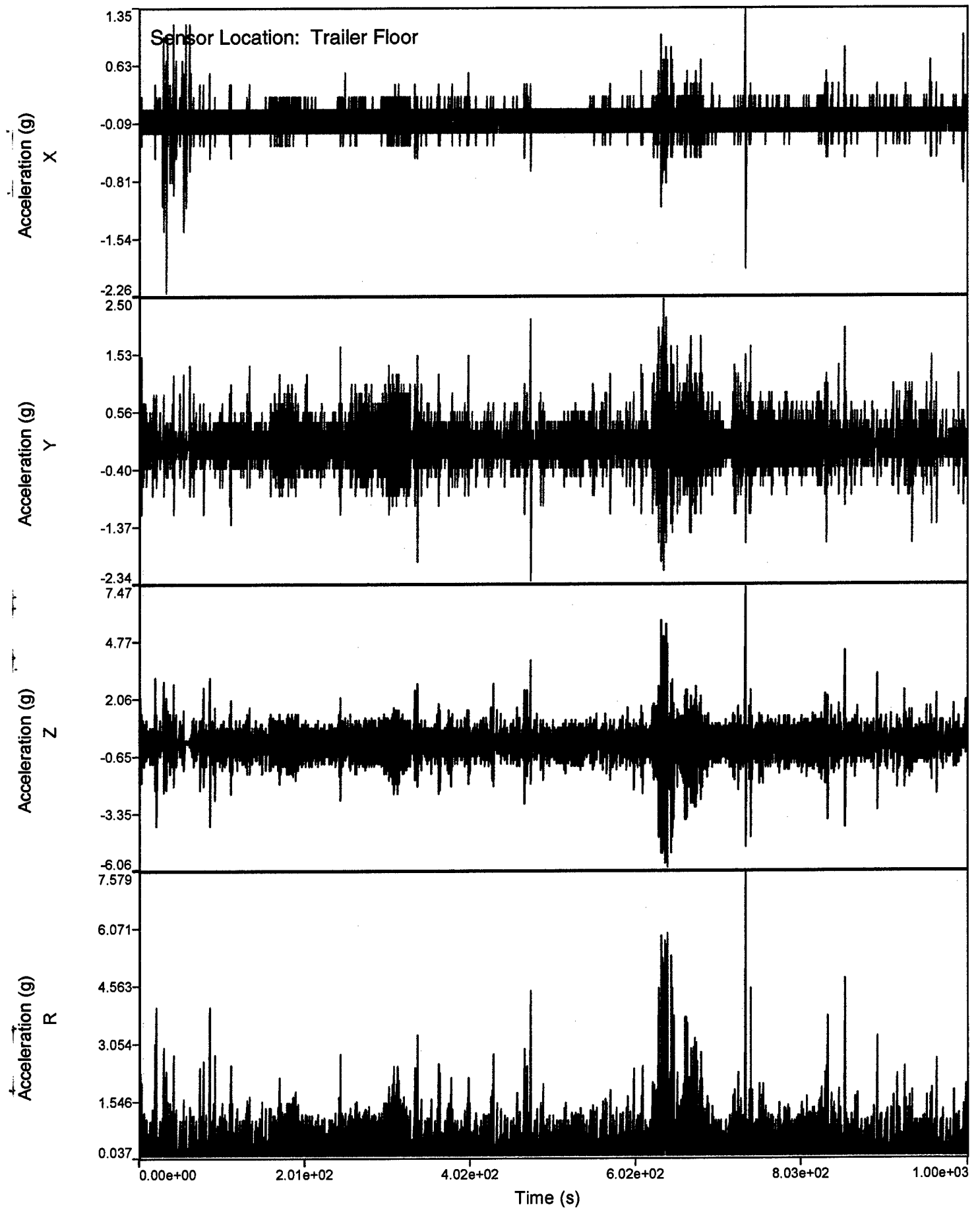

Testing Dates: 22-26 August 2002

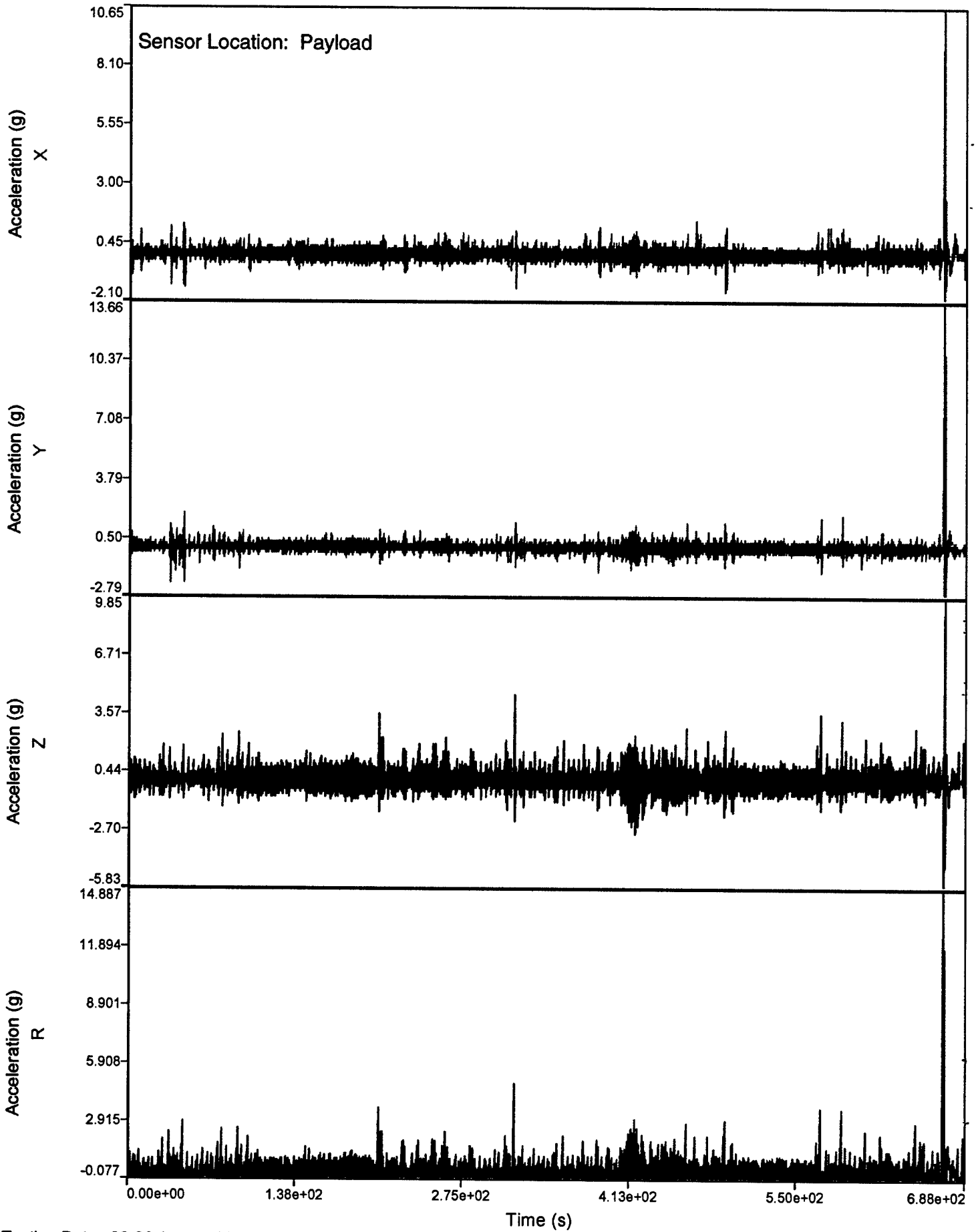

Testing Date: 22-26 August 2002

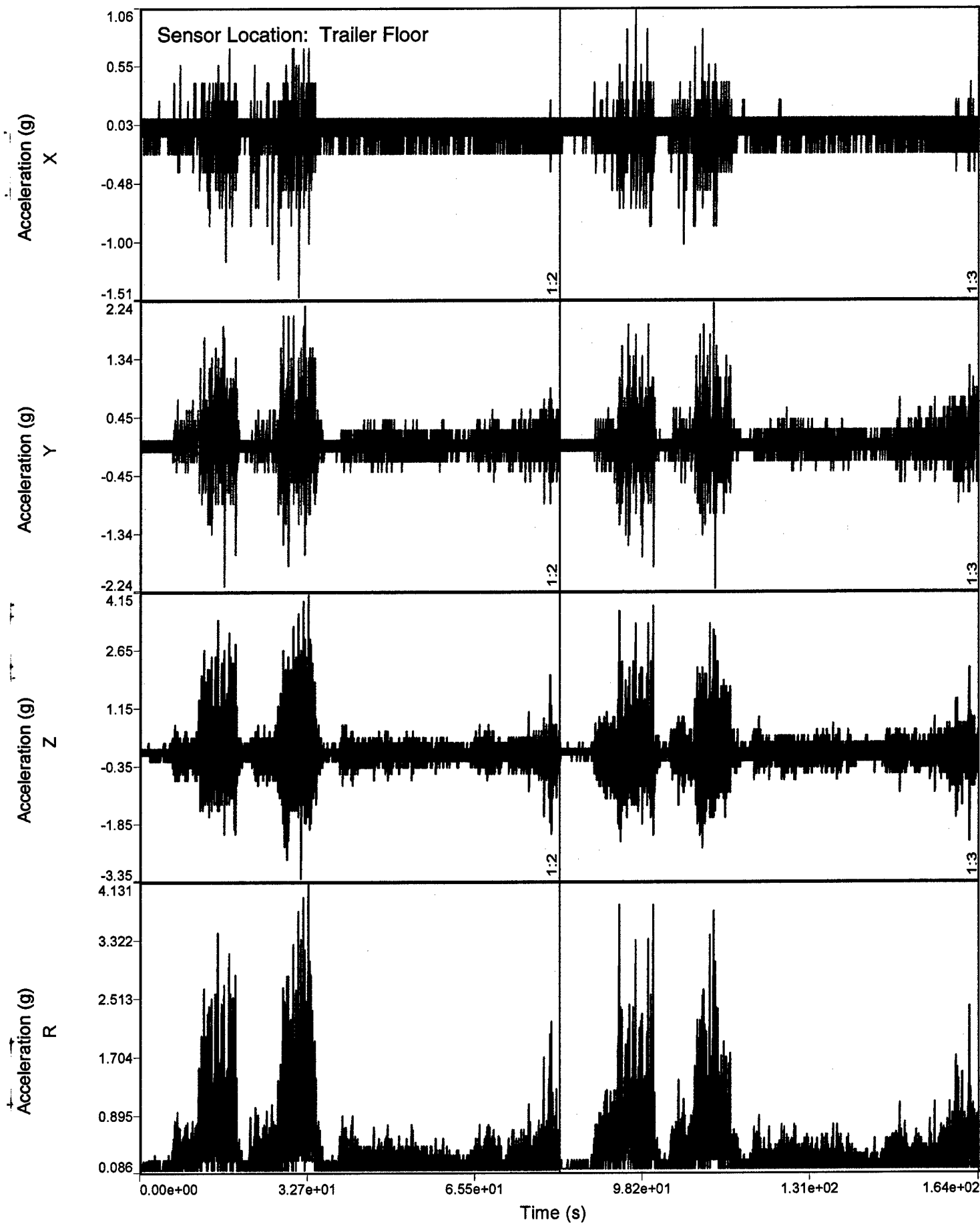

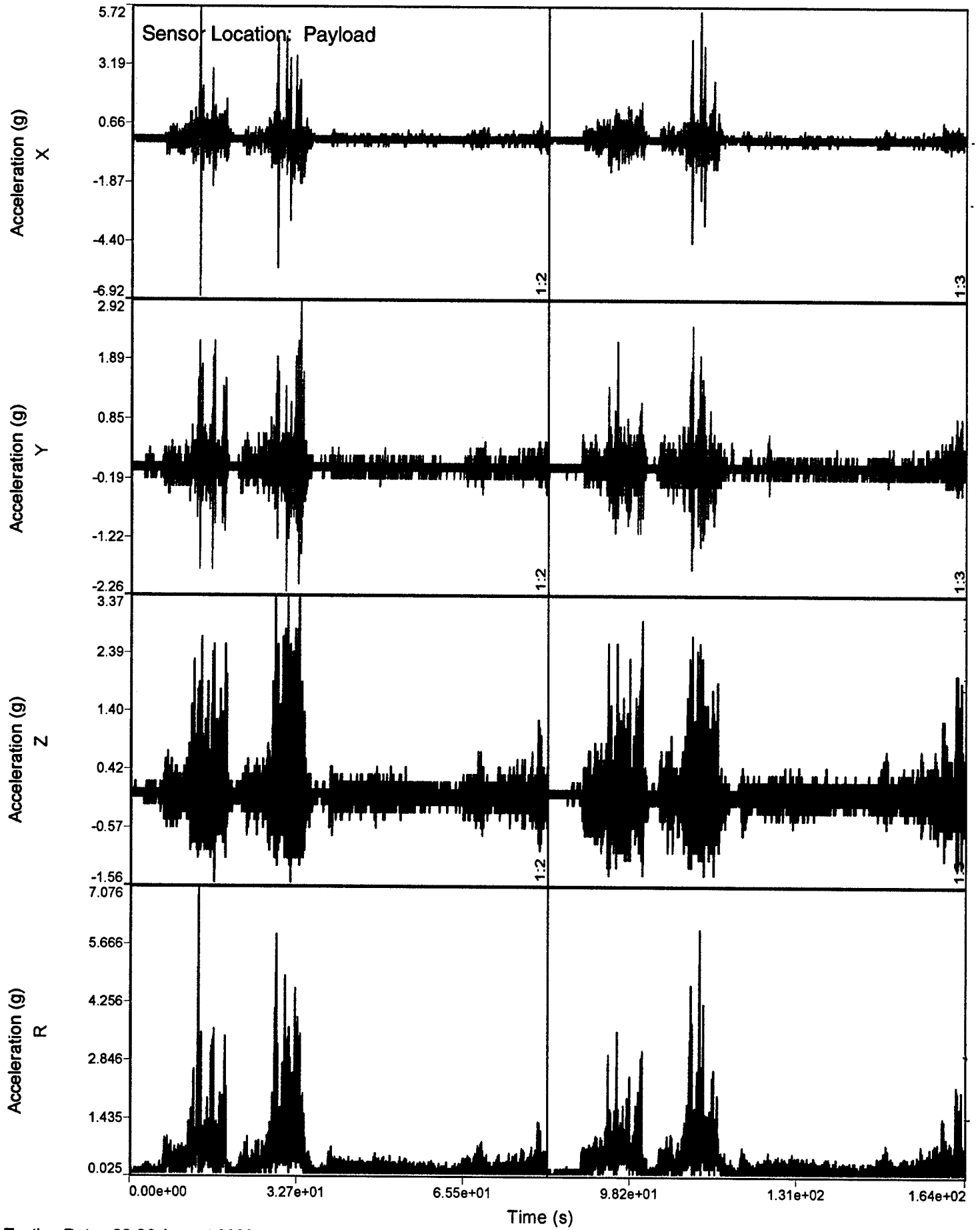

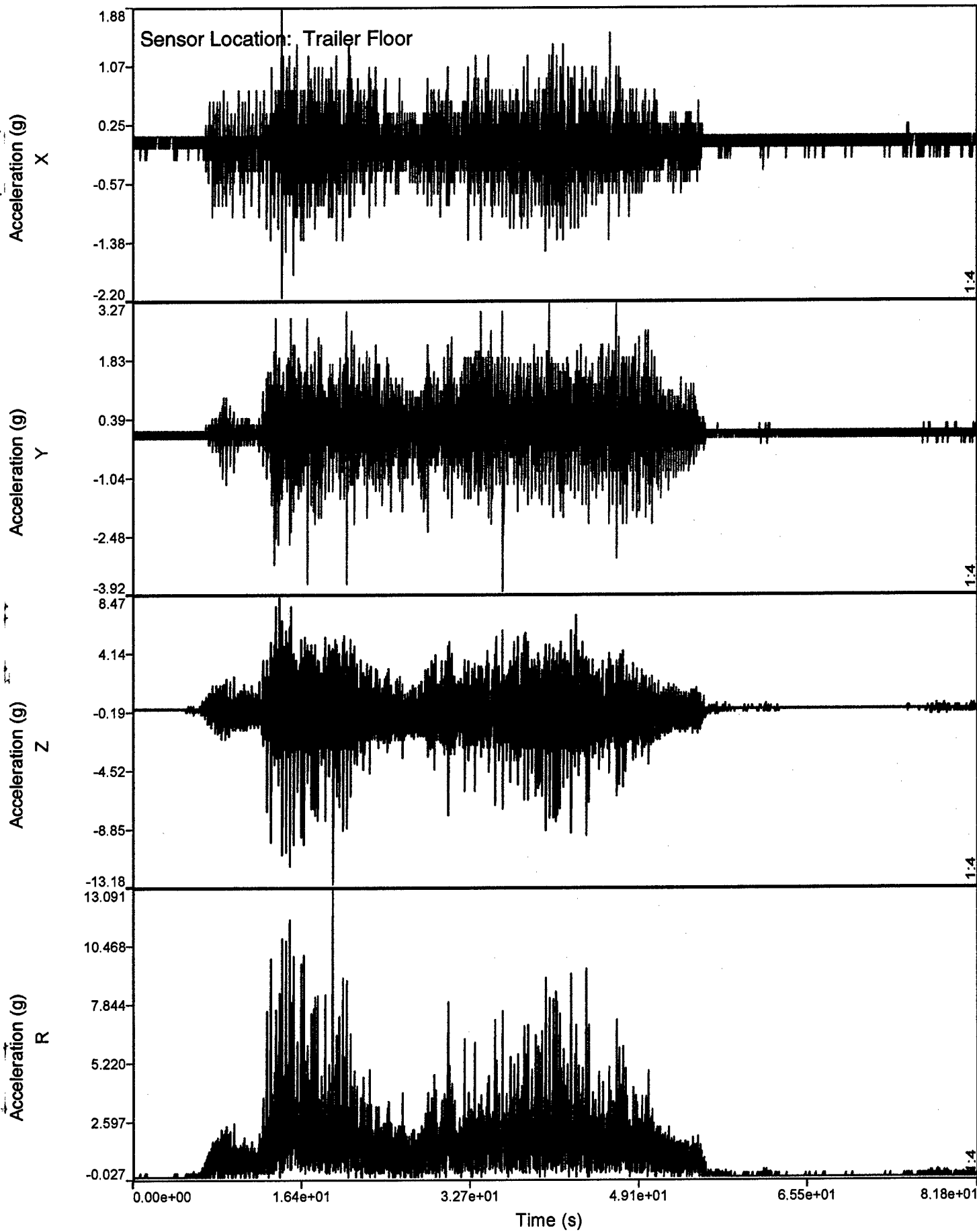

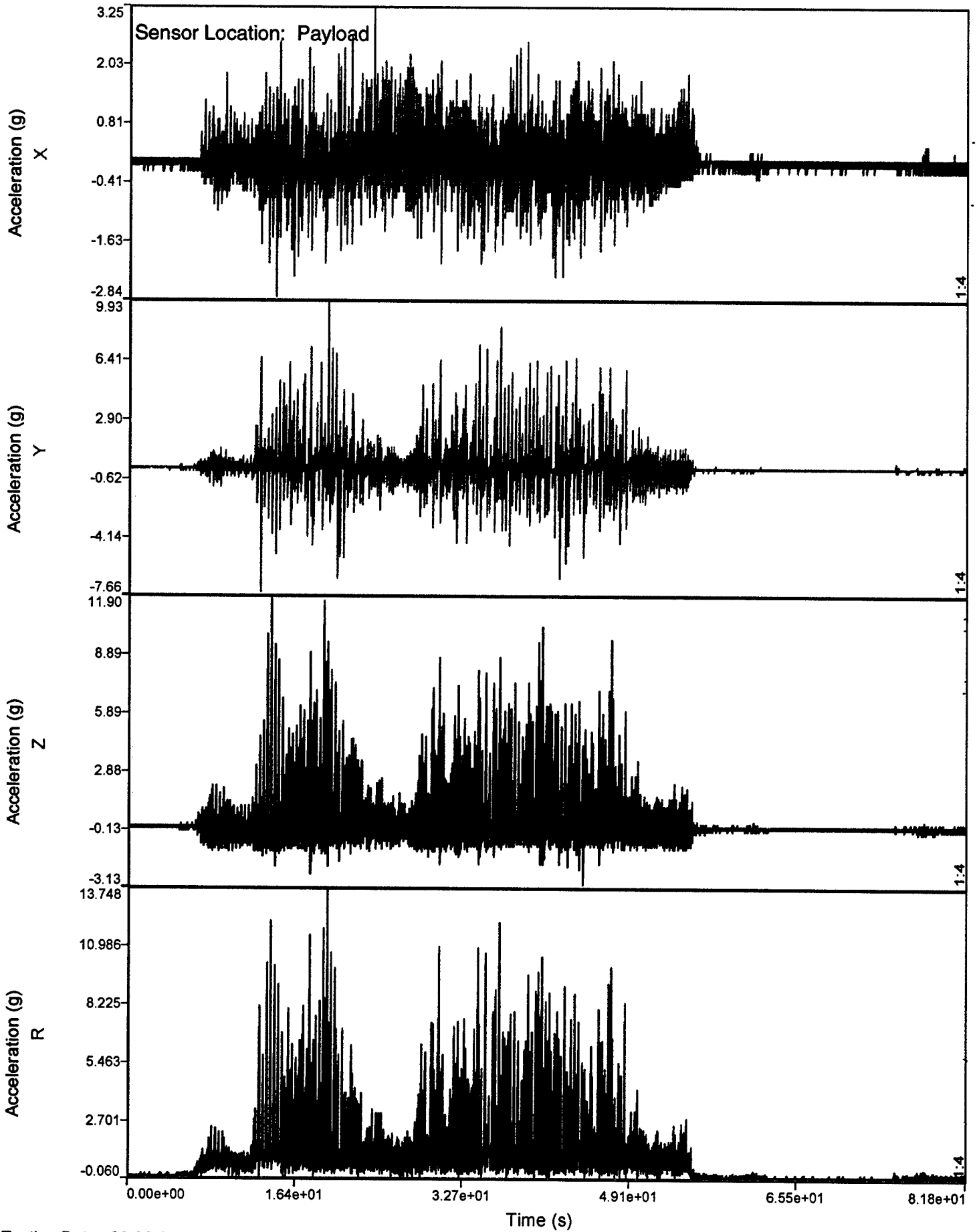

Testing Date: 22-26 August 2002

PART 7- DRAWINGS

The following drawings represent the load configuration that was subjected to the test criteria.

TEST SERIES NO. 2

TEST SKETCH FOR THE TESTING OF NAILED FLOOR-LINE BLOCKING OF PA116 METAL CONTAINERS ON WOOD PALLETS

THIS FIVE PAGE DOCUMENT DEPICTS PROCEDURES FOR NAILED FLOOR-LINE BLOCKING TESTING OF BALLAST FILLED PA116 CYLINDRICAL METAL CONTAINERS ON WOOD PALLETS.

Prepared during July 2002 by:
U.S. Army Defense Ammunition Center
ATTN: SOSAC-DET
McAlester, OK 74501
POC: Mr. Gregory Willis
DSN 956-8075
Comm (918) 420-8075
Fax 956-8811
E-mail: gregory.willis@dac.army.mil

Gregory L. Willis
Gregory L. Willis
Acting Chief, Transportation Engineering Division

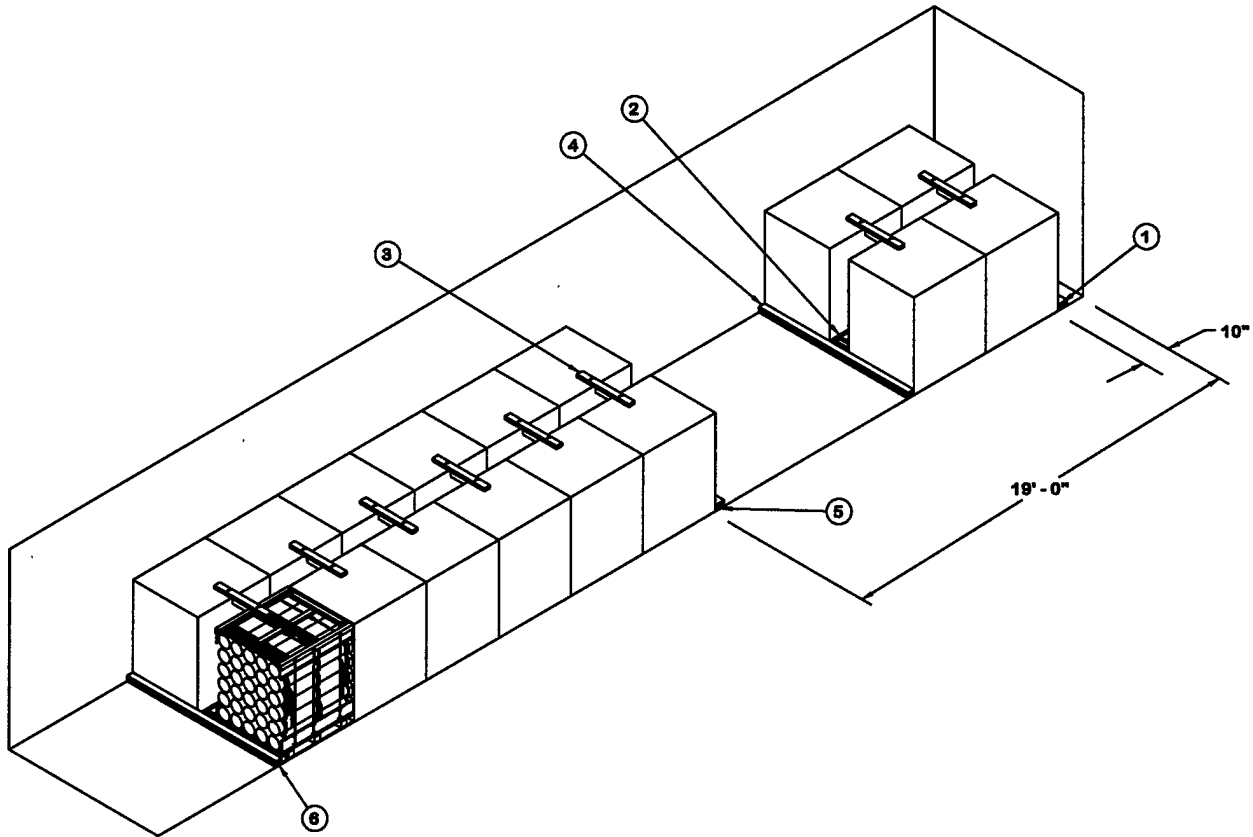

ISOMETRIC VIEW

LOAD AS SHOWN

ITEM	QUANTITY	WEIGHT (APPROX)
PALLET UNIT	16	38,592 LBS
DUNNAGE		254 LBS
TOTAL WEIGHT		38,846 LBS (APPROX)

BILL OF MATERIAL

LUMBER	LINEAR FEET	BOARD FEET
2" X 4"	141	94
2" X 6"	31	31
NAILS	NO. REQD	POUNDS
10d (3")	197	3
20d (4")	9	1/4
WIRE, .0800" DIA	40' REQD	2/3 LBS

KEY NUMBERS

- ① FRONT HEADER, 2" X 6" BY TRAILER WIDTH MINUS 1/2" IN LENGTH (DOUBLED) (1 REQD). POSITION AT 10" FROM THE FRONT OF THE TRAILER AS SHOWN. NAIL THE FIRST PIECE TO THE TRAILER FLOOR W/3-10d NAILS. NAIL THE SECOND PIECE TO THE FIRST W/3-20d NAILS.
- ② ANTI-SWAY BRACE (8 REQD). POSITION ON THE FLOOR BETWEEN LATERALLY ADJACENT PALLET UNITS. SEE THE "ANTI-SWAY BRACE" DETAIL ON PAGE 4.
- ③ TOP-OF-LOAD ANTI-SWAY BRACE (8 REQD). WIRE TIE TO THE PALLET UNITIZING STRAPS WITH .0800" DIA WIRE AS SHOWN BY THE "TIE WIRE APPLICATION" DETAIL ON PAGE 4. SEE THE "TOP-OF-LOAD ANTI SWAY BRACE" DETAIL ON PAGE 5.
- ④ REAR HEADER A, 2" X 4" BY TRAILER WIDTH MINUS 1/2" IN LENGTH (DOUBLED) (1 REQD). POSITION AGAINST THE REAR ANTI-SWAY BRACE ASSEMBLY AND THE PALLET SKIDS. NAIL THE FIRST PIECE TO THE TRAILER FLOOR W/6-10d NAILS. NAIL THE SECOND PIECE TO THE FIRST IN A LIKE MANNER.
- ⑤ FRONT HEADER, 2" X 6" BY TRAILER WIDTH MINUS 1/2" IN LENGTH (DOUBLED) (1 REQD). POSITION AT 19'-0" FROM THE FRONT OF THE TRAILER AS SHOWN. NAIL THE FIRST PIECE TO THE TRAILER FLOOR W/6-10d NAILS. NAIL THE SECOND PIECE TO THE FIRST W/6-20d NAILS.
- ⑥ REAR HEADER B, 2" X 4" BY TRAILER WIDTH MINUS 1/2" IN LENGTH (DOUBLED) (1 REQD). POSITION AGAINST THE AFT BLOCKING ASSEMBLY. NAIL THE FIRST PIECE TO THE TRAILER FLOOR W/12-10d NAILS. NAIL THE SECOND PIECE TO THE FIRST IN A LIKE MANNER.

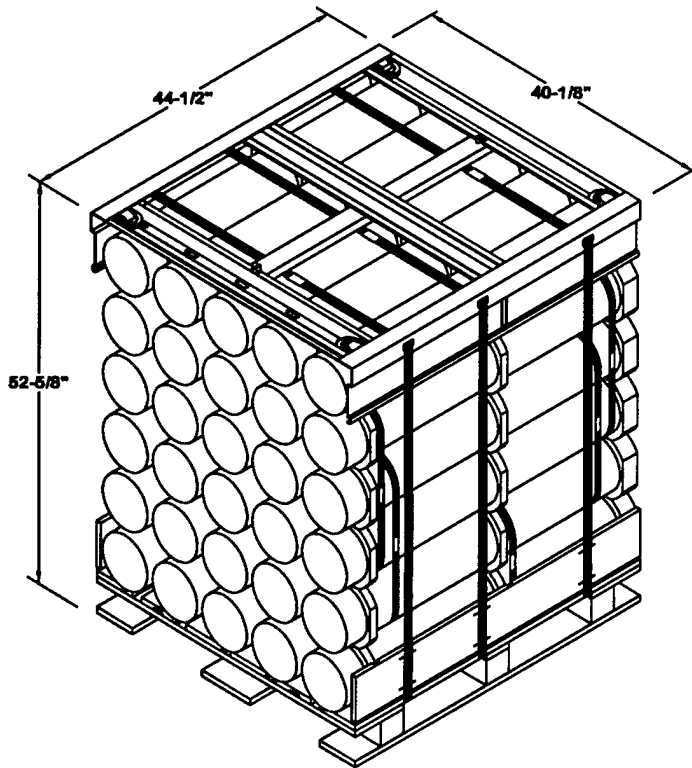

WOOD PALLET UNIT

ITEM	QUANTITY	WEIGHT (APPROX)
CONTAINERS OF 120MM CARTRIDGES (INERT LOADED) AT 75 LBS	30	2,250 LBS (APPROX)
DUNNAGE		85 LBS
PALLET		77 LBS
TOTAL WEIGHT		2,412 LBS (APPROX)
CUBE		54.2 CU FT

NOTE: PALLET UNIT CONSTRUCTED IN ACCORDANCE WITH UNITIZATION PROCEDURES DELINEATED WITHIN DRAWING 19-48-4079/7B.

GENERAL NOTES

- A. WHEN STEEL STRAPPING IS SEALED AT AN END-OVER END LAP JOINT, A MINIMUM OF ONE SEAL WITH TWO PAIR OF NOTCHES WILL BE USED TO SEAL THE JOINT WHEN A NOTCH-TYPE SEALER IS BEING USED. A MINIMUM OF TWO SEALS, BUTTED TOGETHER WITH TWO PAIR OF CRIMPS PER SEAL WILL BE USED TO SEAL THE JOINT WHEN A CRIMP-TYPE SEALER IS BEING USED. REFER TO THE "STRAP JOINT A" AND "STRAP JOINT B" DETAIL AT RIGHT.
- B. DUNNAGE LUMBER SPECIFIED THROUGHOUT THIS PROCEDURAL DRAWING IS OF NOMINAL SIZE. FOR EXAMPLE, 2" X 4" MATERIAL IS ACTUALLY 1-1/2" THICK BY 3-1/2" WIDE AND 2" X 6" MATERIAL IS ACTUALLY 1-1/2" THICK BY 5-1/2" WIDE.
- C. NOTICE: A STAGGERED NAILING PATTERN WILL BE USED WHEREVER POSSIBLE WHEN NAILS ARE DRIVEN INTO JOINTS OF DUNNAGE ASSEMBLIES. ALSO, A STAGGERED NAILING PATTERN WILL BE USED WHEN DUNNAGE IS NAILED TO THE FLOOR OF THE TRANSPORTING VEHICLE, OR WHEN LAMINATING DUNNAGE. THE NAILING PATTERN WILL BE ADJUSTED AS REQUIRED SO THAT A NAIL DOES NOT PENETRATE INTO OR NEAR A CRACK BETWEEN FLOOR BOARDS. ADDITIONALLY, THE NAILING PATTERN FOR AN UPPER PIECE OF LAMINATED DUNNAGE WILL BE ADJUSTED AS REQUIRED SO THAT A NAIL FOR THAT PIECE WILL NOT BE DRIVEN THROUGH THE PIECE ONTO OR RIGHT BESIDE A NAIL IN A LOWER PIECE.
- D. PORTIONS OF THE TRAILER, SUCH AS SIDEWALLS, ENDWALLS, AND ROOFS, HAVE NOT BEEN SHOWN IN THE LOAD VIEW ON PAGE 2 FOR CLARITY PURPOSES.

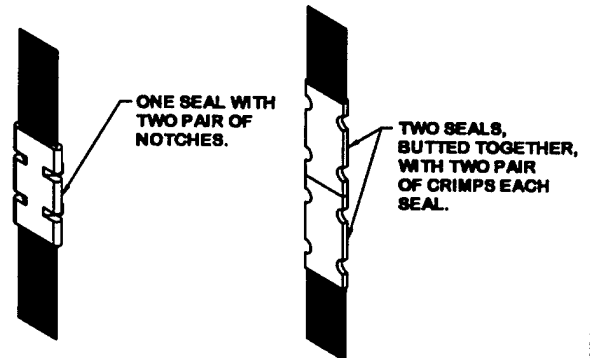

STRAP JOINT A

METHOD OF SECURING A STRAP JOINT WHEN USING A NOTCH-TYPE SEALER.

STRAP JOINT B

METHOD OF SECURING A STRAP JOINT WHEN USING A CRIMP-TYPE SEALER.

MATERIAL SPECIFICATIONS

- LUMBER** - - - - - : SEE TM 743-200-1 (DUNNAGE LUMBER).
- NAILS** - - - - - : ASTM F1667; COMMON STEEL NAILS (NLCMS).
- STRAPPING, STEEL** - - : ASTM D3953; FLAT STRAPPING, TYPE 1 HEAVY DUTY, FINISH A, B (GRADE 2), OR C.
- SEAL, STRAP** - - - - : ASTM D3953; CLASS H, FINISH A, B (GRADE 2), OR C, DOUBLE NOTCH TYPE, STYLE I, II, OR IV.
- WIRE, CARBON STEEL** - : ASTM A853; ANNEALED AT FINISH, BLACK OXIDE FINISH, .0800" DIA, GRADE 1006 OR BETTER.

END-OVER-END LAP JOINT DETAILS

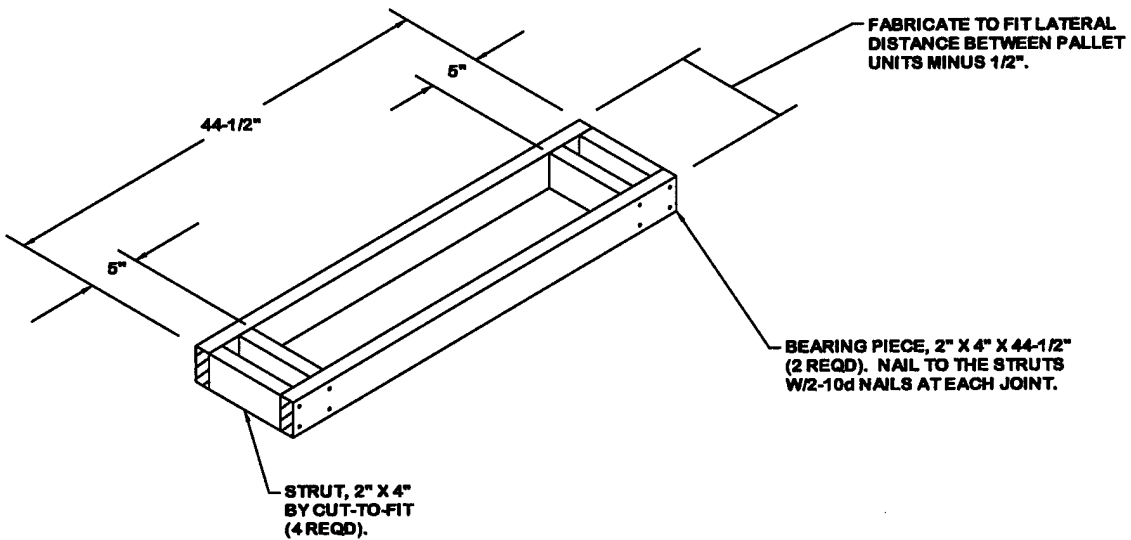

ANTI-SWAY BRACE

THIS ASSEMBLY IS DESIGNED FOR USE ON THE FLOOR BETWEEN LATERALLY ADJACENT PALLET UNITS. NOTE THAT AN ASSEMBLY NEED NOT BE CONSTRUCTED FOR A TIGHT FIT; UP TO 1/2" VOID IS PERMITTED.

INDICATES TOP-OF-LOAD ANTI-SWAY BRACE. SEE THE DETAIL ON PAGE 5.

.0800" DIA WIRE BY LENGTH TO SUIT. FORM TWO LOOPS AROUND TOP-OF-LOAD ANTI-SWAY BRACE SUPPORT PIECE AND TWIST TO PREVENT DISPLACEMENT. THREAD EACH END OF THE WIRE UNDER AND AROUND THE CENTER UNITIZING STRAP ON THE UNIT AND TWIST WIRE TO SELF AS SHOWN. PARTIALLY DRIVE 1-10d NAIL INTO SUPPORT PIECE AND BEND NAIL OVER WIRE.

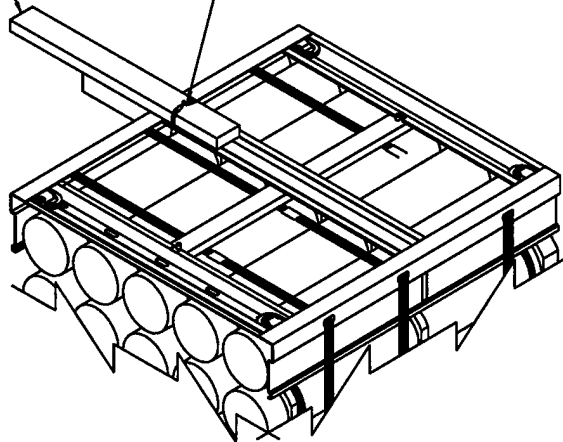

TIE WIRE APPLICATION

DEPICTED ABOVE IS A PARTIAL VIEW SHOWING THE TOP LAYERS OF A PALLET UNIT. ADJACENT TIE WIRE NOT SHOWN ON ANTI-SWAY BRACE.

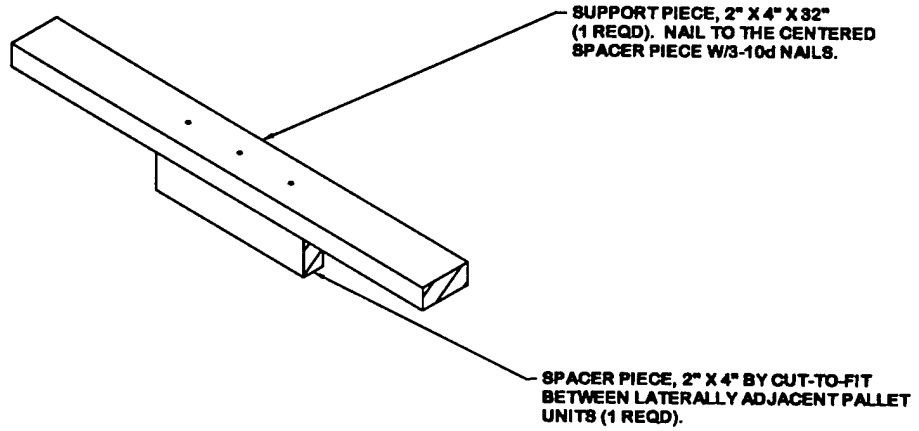

TOP-OF-LOAD ANTI-SWAY BRACE

TEST SERIES NO. 2

TEST SKETCH FOR THE TESTING OF NAILED FLOOR-LINE BLOCKING OF PA116 METAL CONTAINERS ON METAL PALLETS

THIS FIVE PAGE DOCUMENT DEPICTS PROCEDURES FOR NAILED FLOOR-LINE BLOCKING TESTING OF BALLAST FILLED PA116 CYLINDRICAL METAL CONTAINERS ON METAL PALLETS.

Prepared during July 2002 by:
U.S. Army Defense Ammunition Center
ATTN: SOSAC-DET
McAlester, OK 74501
POC: Mr. Gregory Willis
DSN 956-8075
Comm (918) 420-8075
Fax 956-8811
E-mail: gregory.willis@dac.army.mil

Gregory L. Willis

Gregory L. Willis
Acting Chief, Transportation Engineering Division

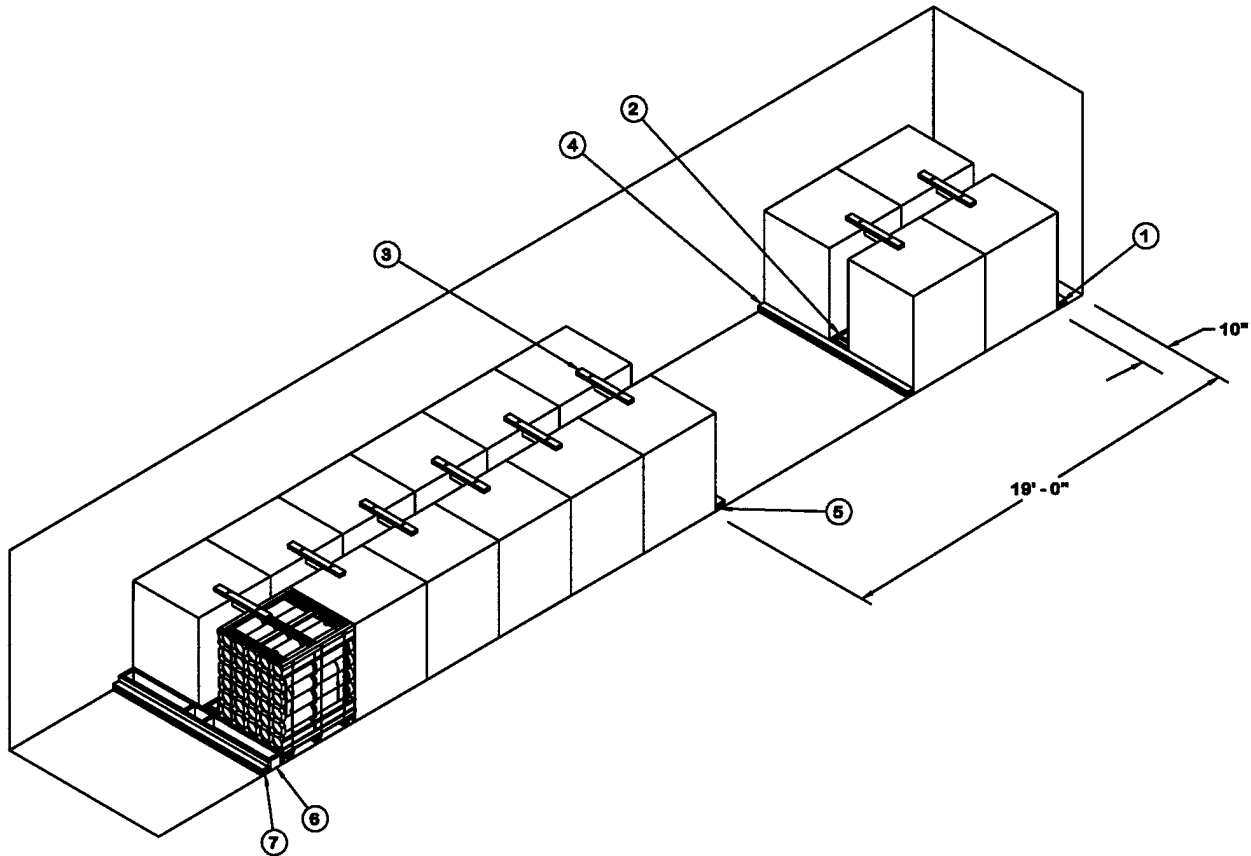

ISOMETRIC VIEW

KEY NUMBERS

- ① FRONT HEADER, 2" X 6" BY TRAILER WIDTH MINUS 1/2" IN LENGTH (DOUBLED) (1 REQD). POSITION AT 10" FROM THE FRONT OF THE TRAILER AS SHOWN. NAIL THE FIRST PIECE TO THE TRAILER FLOOR W/3-10d NAILS. NAIL THE SECOND PIECE TO THE FIRST W/3-20d NAILS.
- ② ANTI-SWAY BRACE (8 REQD). POSITION ON THE FLOOR BETWEEN LATERALLY ADJACENT PALLET UNITS. SEE THE "ANTI-SWAY BRACE" DETAIL ON PAGE 4.
- ③ TOP-OF-LOAD ANTI-SWAY BRACE (8 REQD). WIRE TIE TO THE PALLET UNITIZING STRAPS WITH .0800" DIA WIRE AS SHOWN BY THE "TIE WIRE APPLICATION" DETAIL ON PAGE 4. SEE THE "TOP-OF-LOAD ANTI SWAY BRACE" DETAIL ON PAGE 5.
- ④ REAR HEADER A, 2" X 4" BY TRAILER WIDTH MINUS 1/2" IN LENGTH (DOUBLED) (1 REQD). POSITION AGAINST THE REAR ANTI-SWAY BRACE ASSEMBLY AND THE PALLET SKIDS. NAIL THE FIRST PIECE TO THE TRAILER FLOOR W/8-10d NAILS. NAIL THE SECOND PIECE TO THE FIRST IN A LIKE MANNER.
- ⑤ FRONT HEADER, 2" X 6" BY TRAILER WIDTH MINUS 1/2" IN LENGTH (DOUBLED) (1 REQD). POSITION AT 19'-0" FROM THE FRONT OF THE TRAILER AS SHOWN. NAIL THE FIRST PIECE TO THE TRAILER FLOOR W/8-10d NAILS. NAIL THE SECOND PIECE TO THE FIRST W/8-20d NAILS.
- ⑥ AFT BLOCKING ASSEMBLY (1 REQD). POSITION AT THE REAR OF THE LOAD AS SHOWN. SEE THE DETAIL ON PAGE 5.
- ⑦ REAR HEADER B, 2" X 4" BY TRAILER WIDTH MINUS 1/2" IN LENGTH (DOUBLED) (1 REQD). POSITION AGAINST THE AFT BLOCKING ASSEMBLY. NAIL THE FIRST PIECE TO THE TRAILER FLOOR W/12-10d NAILS. NAIL THE SECOND PIECE TO THE FIRST IN A LIKE MANNER. TOENAIL THROUGH REAR HEADER B INTO THE BEARING PIECE OF THE AFT BLOCKING ASSEMBLY, PIECE MARKED ⑥, W/4-12d NAILS.

LOAD AS SHOWN

ITEM	QUANTITY	WEIGHT (APPROX)
PALLET UNIT	16	39,360 LBS
DUNNAGE		290 LBS
TOTAL WEIGHT		39,650 LBS (APPROX)

BILL OF MATERIAL

LUMBER	LINEAR FEET	BOARD FEET
2" X 4"	143	95
2" X 6"	48	48
NAILS	NO. REQD	POUNDS
10d (3")	227	3-1/2
12d (3-1/4")	4	NIL
20d (4")	9	1/4
WIRE, .0800" DIA	40' REQD	2/3 LBS

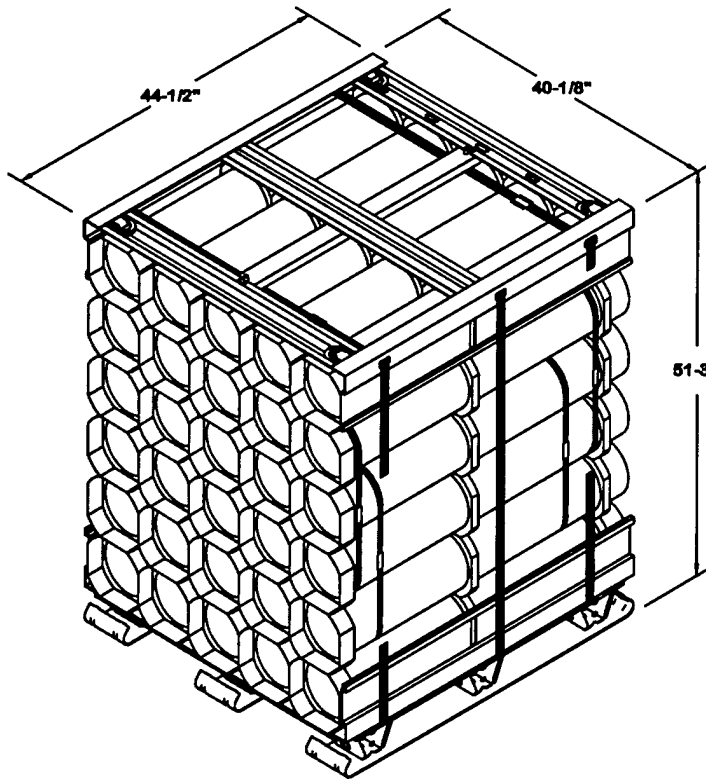

METAL PALLET UNIT

ITEM	QUANTITY	WEIGHT (APPROX)
CONTAINERS OF 120MM CARTRIDGES (INERT LOADED) AT 75 LBS	30	2,250 LBS (APPROX)
DUNNAGE		105 LBS
PALLET		105 LBS
TOTAL WEIGHT		2,460 LBS (APPROX)
CUBE		53.5 CU FT

NOTE: PALLET UNIT CONSTRUCTED IN ACCORDANCE WITH UNITIZATION PROCEDURES DELINEATED WITHIN DRAWING 19-48-4231/48.

GENERAL NOTES

- A. WHEN STEEL STRAPPING IS SEALED AT AN END-OVER END LAP JOINT, A MINIMUM OF ONE SEAL WITH TWO PAIR OF NOTCHES WILL BE USED TO SEAL THE JOINT WHEN A NOTCH-TYPE SEALER IS BEING USED. A MINIMUM OF TWO SEALS, BUTTED TOGETHER WITH TWO PAIR OF CRIMPS PER SEAL WILL BE USED TO SEAL THE JOINT WHEN A CRIMP-TYPE SEALER IS BEING USED. REFER TO THE "STRAP JOINT A" AND "STRAP JOINT B" DETAIL AT RIGHT.
- B. DUNNAGE LUMBER SPECIFIED THROUGHOUT THIS PROCEDURAL DRAWING IS OF NOMINAL SIZE. FOR EXAMPLE, 2" X 4" MATERIAL IS ACTUALLY 1-1/2" THICK BY 3-1/2" WIDE AND 2" X 6" MATERIAL IS ACTUALLY 1-1/2" THICK BY 5-1/2" WIDE.
- C. **NOTICE:** A STAGGERED NAILING PATTERN WILL BE USED WHEREVER POSSIBLE WHEN NAILS ARE DRIVEN INTO JOINTS OF DUNNAGE ASSEMBLIES. ALSO, A STAGGERED NAILING PATTERN WILL BE USED WHEN DUNNAGE IS NAILED TO THE FLOOR OF THE TRANSPORTING VEHICLE, OR WHEN LAMINATING DUNNAGE. THE NAILING PATTERN WILL BE ADJUSTED AS REQUIRED SO THAT A NAIL DOES NOT PENETRATE INTO OR NEAR A CRACK BETWEEN FLOOR BOARDS. ADDITIONALLY, THE NAILING PATTERN FOR AN UPPER PIECE OF LAMINATED DUNNAGE WILL BE ADJUSTED AS REQUIRED SO THAT A NAIL FOR THAT PIECE WILL NOT BE DRIVEN THROUGH THE PIECE ON TO OR RIGHT BESIDE A NAIL IN A LOWER PIECE.
- D. PORTIONS OF THE TRAILER, SUCH AS SIDEWALLS, ENDWALLS, AND ROOFS, HAVE NOT BEEN SHOWN IN THE LOAD VIEW ON PAGE 2 FOR CLARITY PURPOSES.

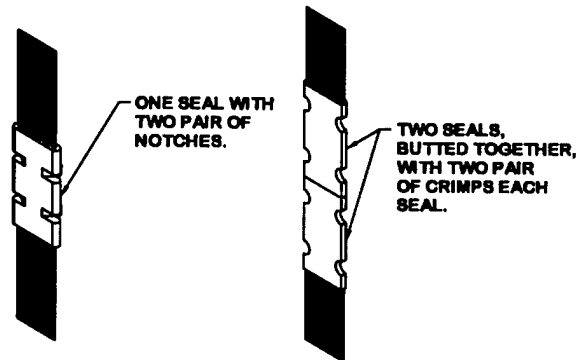

STRAP JOINT A

METHOD OF SECURING A STRAP JOINT WHEN USING A NOTCH-TYPE SEALER.

STRAP JOINT B

METHOD OF SECURING A STRAP JOINT WHEN USING A CRIMP-TYPE SEALER.

MATERIAL SPECIFICATIONS

- LUMBER** - - - - - : SEE TM 743-200-1 (DUNNAGE LUMBER).
- NAILS** - - - - - : ASTM F1667; COMMON STEEL NAILS (NLCS).
- STRAPPING, STEEL** - - : ASTM D3953; FLAT STRAPPING, TYPE 1 HEAVY DUTY, FINISH A, B (GRADE 2), OR C.
- SEAL, STRAP** - - - - : ASTM D3953; CLASS H, FINISH A, B (GRADE 2), OR C, DOUBLE NOTCH TYPE, STYLE I, II, OR IV.
- WIRE, CARBON STEEL** - : ASTM A853; ANNEALED AT FINISH, BLACK OXIDE FINISH, .0800" DIA, GRADE 1006 OR BETTER.

END-OVER-END LAP JOINT DETAILS

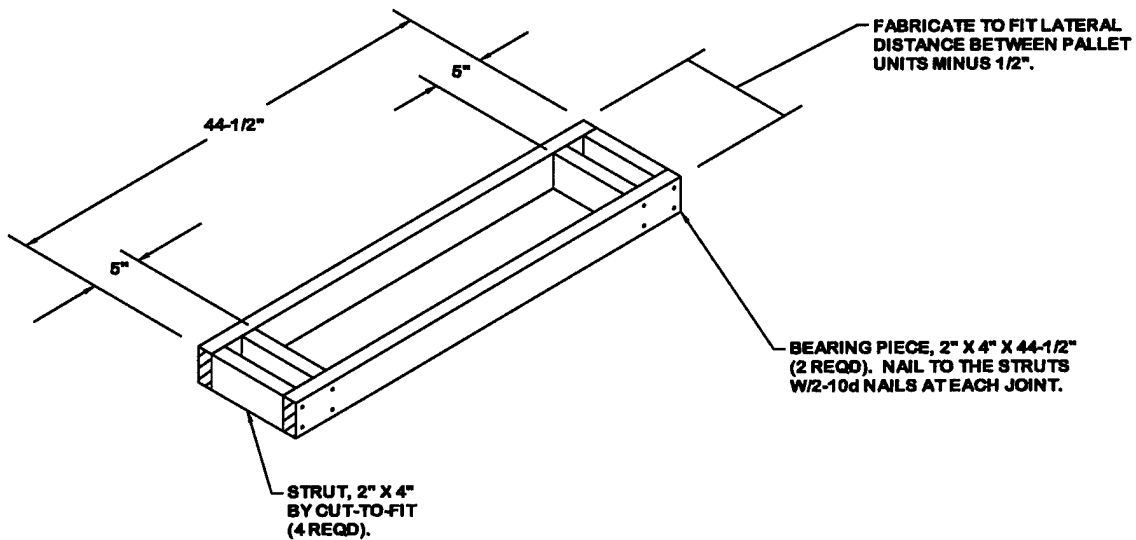

ANTI-SWAY BRACE

THIS ASSEMBLY IS DESIGNED FOR USE ON THE FLOOR BETWEEN LATERALLY ADJACENT PALLET UNITS. NOTE THAT AN ASSEMBLY NEED NOT BE CONSTRUCTED FOR A TIGHT FIT; UP TO 1/2" VOID IS PERMITTED.

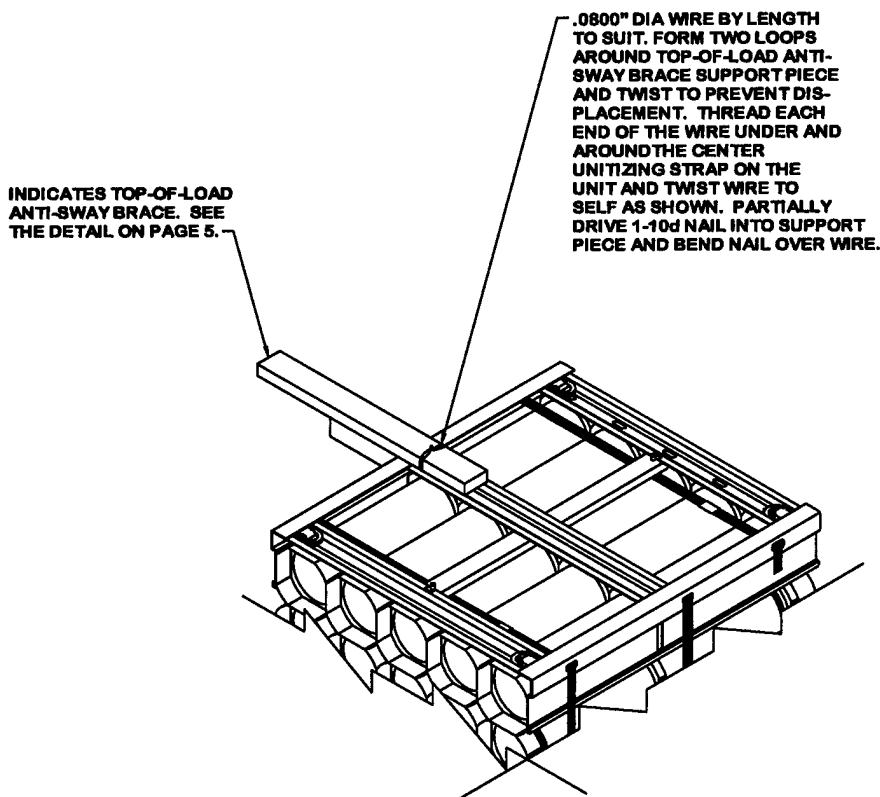

TIE WIRE APPLICATION

DEPICTED ABOVE IS A PARTIAL VIEW SHOWING THE TOP LAYERS OF A PALLET UNIT. ADJACENT TIE WIRE NOT SHOWN ON ANTI-SWAY BRACE.

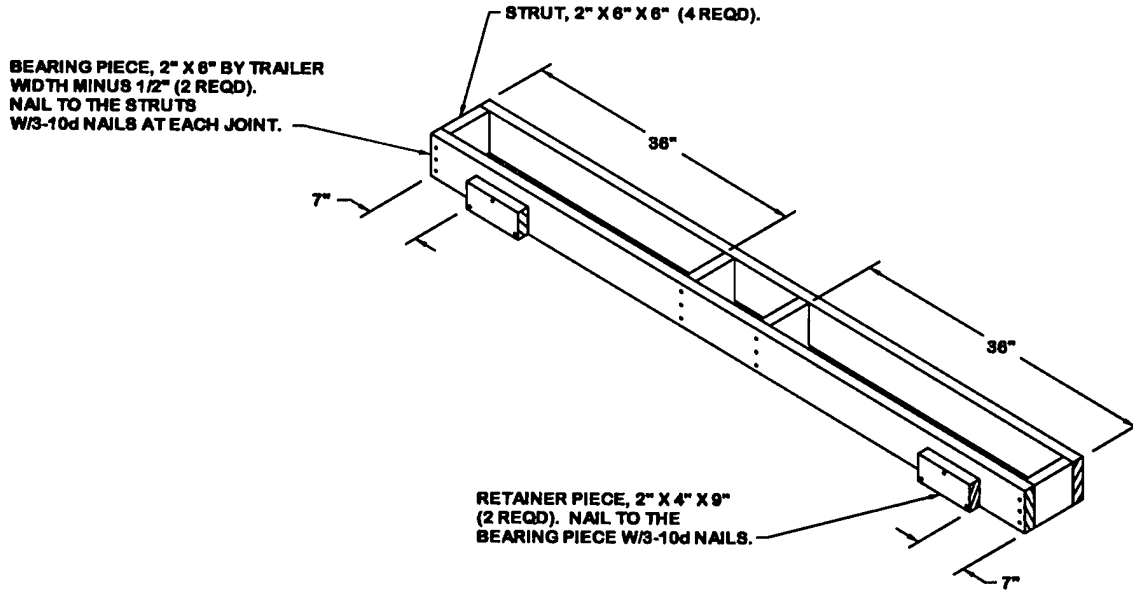

AFT BLOCKING ASSEMBLY

THE ASSEMBLY DEPICTED ABOVE IS FOR USE AT THE AFT END OF A LOAD. NOTE THAT THE ABOVE VIEW IS ROTATED 180 DEGREES FROM THE POSITION IN WHICH IT WILL BE INSTALLED.

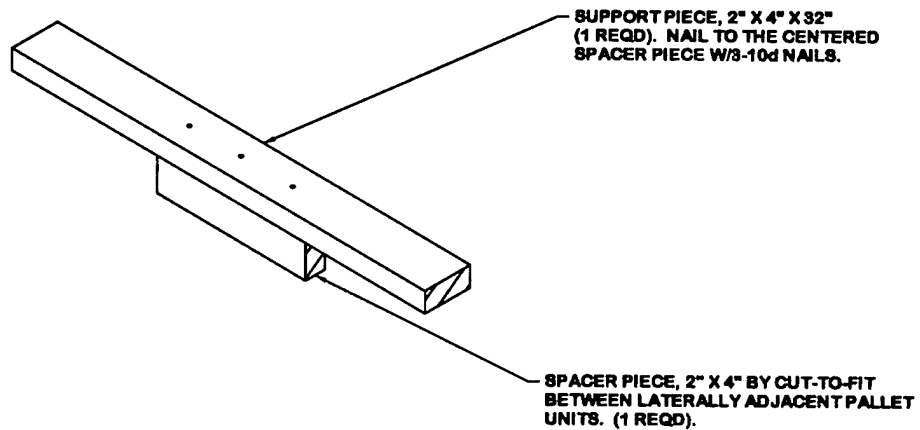

TOP-OF-LOAD ANTI-SWAY BRACE

DETAILS

PAGE 5

TEST SKETCH

LOADING AND BRACING (TL & LTL) IN VAN TRAILERS OF PALLETIZED SEPARATE LOADING PROJECTILES

INDEX

ITEM	PAGE(S)
GENERAL NOTES, AND MATERIAL SPECIFICATIONS	2, 3
PALLET UNIT DETAILS-	4, 5
155MM PROJECTILE, 8/SMALL PALLET	6-10
155MM PROJECTILE, 8/LARGE PALLET	12-16
8" PROJECTILE, 6/SMALL PALLET	18-23
8" PROJECTILE, 6/LARGE PALLET	24-31
8" PROJECTILE, 6 TALL/SMALL PALLET	32-39
DETAILS	11, 17, 21, 29, 40-46

● CAUTION: THE LOADING PROCEDURES SHOWN HEREIN ARE ONLY APPLICABLE TO HIGHWAY MOVEMENTS, NOT TRAILER-ON-FLATCAR (TOFC) MOVEMENTS.

U.S. ARMY MATERIEL COMMAND DRAWING

APPROVED, U.S. ARMY INDUSTRIAL OPERATIONS COMMAND <i>Timothy R. Fore</i>	ENGINEER	BASIC		DO NOT SCALE			
		REV.		WEBSITE: HTTP://WWW.DAC.ARMY.MIL			
	TECHNICIAN	BASIC	RALPH ARNOLD	JULY 1961			
		REV.	RICHARD HAYNES				
DRAFTSMAN	BASIC	LEONARD/SPOULE	REVISION NO. 6		JULY 1998		
	REV.		SEE THE REVISION LISTING ON PAGE 3				
APPROVED BY ORDER OF COMMANDING GENERAL U.S. ARMY MATERIEL COMMAND <i>Arthur Rodolfo</i> U.S. ARMY DEFENSE AMMUNITION CENTER	TRANSPORTATION ENGINEERING DIVISION		<i>W. R. French</i>	CLASS	DIVISION	DRAWING	FILE
	VALIDATION ENGINEERING DIVISION		<i>M. Keenan</i>	19	48	4019	11PE1000
	LOGISTICS ENGINEERING OFFICE		<i>J. J. Michele</i>				

PROJECT FSA 20-59

GENERAL NOTES

(GENERAL NOTES CONTINUED)

- A. THIS DOCUMENT HAS BEEN PREPARED AND ISSUED IN ACCORDANCE WITH AR 740-1 AND AUGMENTS TM 743-200-1 (CHAPTER 5).
- B. THE OUTLOADING PROCEDURES SPECIFIED IN THIS DRAWING ARE APPLICABLE TO PALLETIZED SEPARATE LOADING PROJECTILES. SUBSEQUENT REFERENCE TO PALLET UNIT MEANS THE PALLET UNIT WITH AMMUNITION ITEMS.
- C. LADING DATA: SEE PAGES 4 AND 5.
- D. THE OUTLOADING PROCEDURES DEPICTED WITHIN THIS DOCUMENT ARE APPLICABLE FOR SHIPMENTS IN CONVENTIONAL TYPE VAN TRAILERS AND APPLY TO TRAILERS HAVING WOOD, OR WOOD AND METAL, OR ALL METAL FLOORS. REGARDLESS OF THE DIMENSIONS OF THE VAN TRAILERS SHOWN, THE PROCEDURES ARE ALSO APPLICABLE FOR TRAILERS WHICH ARE 89" THRU 99" IN WIDTH AND FOR TRAILERS OF OTHER LENGTHS FROM THE SHORTEST TO THE LONGEST AVAILABLE (REF: 24' TO 53'), AND FOR STRAIGHT TRUCK VANS. THE SPECIFIED BRACING IS ADEQUATE FOR LOADS WEIGHING UP TO AND INCLUDING THE MAXIMUM WEIGHTS PERMITTED BY LAW.
- E. SELECTION OF A VEHICLE FOR THE TRANSPORT OF THE DESIGNATED ITEM IS THE RESPONSIBILITY OF THE ORIGINATING CARRIER AND THE SHIPPER. ONLY VEHICLES IN ACCORDANCE WITH THE REQUIREMENTS OF THE APPLICABLE REGULATORY DOCUMENTS WILL BE SELECTED FOR USE.
- F. THE GROSS WEIGHT AND AXLE DISTRIBUTION OF WEIGHT FOR A LOAD WILL BE THE RESPONSIBILITY OF THE CARRIER. THE CARRIER WILL ADVISE THE SHIPPER OF THE APPLICABLE LOADING REQUIREMENTS, AND THE SHIPPER WILL LOAD ACCORDINGLY. THE TOTAL WEIGHT OF THE LADING, OF THE DUNNAGE, OF THE TRACTOR, AND OF THE SEMITRAILER CARRYING THE LADING MUST NOT EXCEED THE MAXIMUM GROSS WEIGHT ALLOWED FOR THE STATE OR STATES THRU WHICH THE LOAD IS TO BE TRANSPORTED BY MOTOR CARRIER. LIKEWISE, THE GROSS WEIGHT ON A SINGLE OR TANDEN AXLE MUST NOT EXCEED THE MAXIMUM ALLOWABLE WEIGHT. IF THERE IS ANY DOUBT AS TO WHETHER THE TOTAL GROSS WEIGHT OR AXLE WEIGHT EXCEEDS THE MAXIMUM ALLOWED, WEIGHT SHOULD BE VERIFIED BY ACTUALLY WEIGHING THE LOADED VEHICLE.
- G. NOTICE: A SHIPMENT WILL BE POSITIONED IN THE TRAILER CONSISTENT WITH STATE WEIGHT LAWS. THE NUMBER OF LADING UNITS MAY BE ADJUSTED TO FIT THE SIZE OF THE TRAILER TO BE LOADED OR THE QUANTITY TO BE SHIPPED. COMBINATIONS OF THE OUTLOADING PROCEDURES SPECIFIED MAY BE USED, HOWEVER, THE APPROVED METHODS SHOWN MUST BE FOLLOWED AS CLOSELY AS POSSIBLE FOR BLOCKING, BRACING, AND STAYING OF THE DESIGNATED ITEMS.
- H. THE "LOAD AS SHOWN" FOR MOST OF THE FULL LOADS DEPICTED HEREIN IS BASED ON AN APPROXIMATE LADING WEIGHT OF 43,000 POUNDS. THE SPECIFIED BLOCKING AND BRACING FOR THE FULL LOADS IS ADEQUATE FOR THE RETENTION OF LOADS, UP TO 45,000 POUNDS, IF IT IS DESIRED TO INCREASE THE LADING WEIGHT.
- J. OTHER TYPES OF LADING ITEMS MAY BE LOADED INTO TRAILERS WHICH ARE PARTIALLY LOADED WITH PALLET UNITS OF PROJECTILES, PROVIDING THE TOTAL LOAD IS COMPATIBLE, EXISTING DIRECTIVES ARE NOT VIOLATED, AND THE OTHER LADING ITEMS ARE BLOCKED AND BRACED TO EQUAL THE BLOCKING AND BRACING CRITERIA SPECIFIED HEREIN.
- K. SOME LOADS ARE SHOWN IN TRAILERS HAVING ROUNDED CORNERS AT THE FORWARD END. IF THE CONVENTIONAL VAN TRAILER BEING USED IS EQUIPPED WITH A SQUARE FRONT OR WITH AN INSTALLED BULKHEAD, OMIT THE FORWARD BLOCKING ASSEMBLY, AND POSITION THE PALLET UNITS DIRECTLY AGAINST THE FORWARD PORTION OF THE TRAILER.
- L. WHEN STEEL STRAPPING IS SEALED AT AN END-OVER-END LAP JOINT, A MINIMUM OF ONE SEAL WITH TWO PAIR OF NOTCHES WILL BE USED TO SEAL THE JOINT WHEN A NOTCH-TYPE SEALER IS BEING USED. A MINIMUM OF TWO SEALS, BUTTED TOGETHER WITH TWO PAIR OF CRIMPS PER SEAL WILL BE USED TO SEAL THE JOINT WHEN A CRIMP-TYPE SEALER IS BEING USED. REFER TO THE "STRAP JOINT A" AND "STRAP JOINT B" DETAILS ON PAGE 45.
- M. DUNNAGE LUMBER SPECIFIED THROUGHOUT THIS PROCEDURAL DRAWING IS OF NOMINAL SIZE. FOR EXAMPLE, 2" X 4" MATERIAL IS ACTUALLY 1-1/2" THICK BY 3-1/2" WIDE AND 2" X 6" MATERIAL IS ACTUALLY 1-1/2" THICK BY 5-1/2" WIDE.
- N. NOTICE: A STAGGERED NAILING PATTERN WILL BE USED WHEREVER POSSIBLE WHEN NAILS ARE DRIVEN INTO JOINTS OF DUNNAGE ASSEMBLIES. ALSO, A STAGGERED NAILING PATTERN WILL BE USED WHEN DUNNAGE IS NAILED TO THE FLOOR OF THE TRANSPORTING VEHICLE, OR WHEN LAMINATING DUNNAGE. THE NAILING PATTERN WILL BE ADJUSTED AS REQUIRED SO THAT A NAIL DOES NOT PENETRATE INTO OR NEAR A CRACK BETWEEN FLOOR BOARDS. ADDITIONALLY, THE NAILING PATTERN FOR AN UPPER PIECE OF LAMINATED DUNNAGE WILL BE ADJUSTED AS REQUIRED SO THAT A NAIL FOR THAT PIECE WILL NOT BE DRIVEN THROUGH THE PIECE ONTO OR RIGHT BESIDE A NAIL IN A LOWER PIECE.
- O. POWER DRIVEN STAPLES MAY BE USED AS ALTERNATIVE FASTENERS FOR NAILS WHEN CONSTRUCTING DUNNAGE ASSEMBLIES WHICH ARE TO BE USED IN THE DELINEATED TRAILER LOADS SHOWN THROUGHOUT THIS DRAWING. THE STAPLES TO BE USED MUST BE EQUAL IN LENGTH TO THE SPECIFIED NAIL SIZE AND MUST BE SUBSTITUTED ON A ONE STAPLE FOR ONE NAIL BASIS. STAPLES WHICH ARE 2-1/2" OR LESS IN LENGTH SHOULD BE IN ACCORDANCE WITH FEDERAL SPECIFICATION ASTM F1667 AS NEARLY AS PRACTICABLE. STAPLES WHICH ARE LONGER THAN 2-1/2" WILL BE A COMMERCIAL GRADE, OF A QUALITY EQUIVALENT TO THOSE MANUFACTURED BY SENCO PRODUCTS INCORPORATED. NOTE: STAPLES WILL NOT BE SUBSTITUTED FOR NAILS IN ANY LOAD RESTRAINING FLOOR DUNNAGE APPLICATION.
- P. THE NUMBER OF PALLET UNITS MAY BE ADJUSTED TO FIT THE CAPACITY OF THE TRAILER BEING LOADED OR THE QUANTITY TO BE SHIPPED. HOWEVER, THE APPROVED METHODS SPECIFIED HEREIN MUST BE FOLLOWED AS CLOSELY AS POSSIBLE FOR BLOCKING, BRACING, AND STAYING OF THE SPECIFIED PALLET UNITS.

(CONTINUED AT RIGHT)

- Q. CAUTION: DO NOT NAIL BLOCKING TO THE TRAILER WALLS. ALL BLOCKING WILL BE WITHIN THE DUNNAGE OR TO THE TRAILER FLOOR, AS INDICATED.
- R. PORTIONS OF THE TRAILERS, SUCH AS SIDEWALLS, END WALLS, AND ROOFS, HAVE NOT BEEN SHOWN IN THE LOAD VIEWS FOR CLARITY PURPOSES.

(CONTINUED ON PAGE 3)

MATERIAL SPECIFICATIONS

- LUMBER ----- : SEE TM 743-200-1 (DUNNAGE LUMBER) AND VOLUNTARY PRODUCTS STANDARD PS 20.
- NAILS ----- : ASTM F1667; COMMON STEEL NAILS (NLCMS OR NLCMS).
- STRAPPING, STEEL ---- : ASTM D3953; FLAT STRAPPING, TYPE 1, HEAVY DUTY, FINISH A, B (GRADE 2), OR C.
- SEAL, STRAP ----- : ASTM D3953; CLASS H, FINISH A, B (GRADE 2), OR C, DOUBLE NOTCH TYPE, STYLE I, II, OR IV.
- WIRE, CARBON STEEL - : ASTM A853; ANNEALED AT FINISH, BLACK OXIDE FINISH, .0800" DIA, GRADE 1006 OR BETTER.

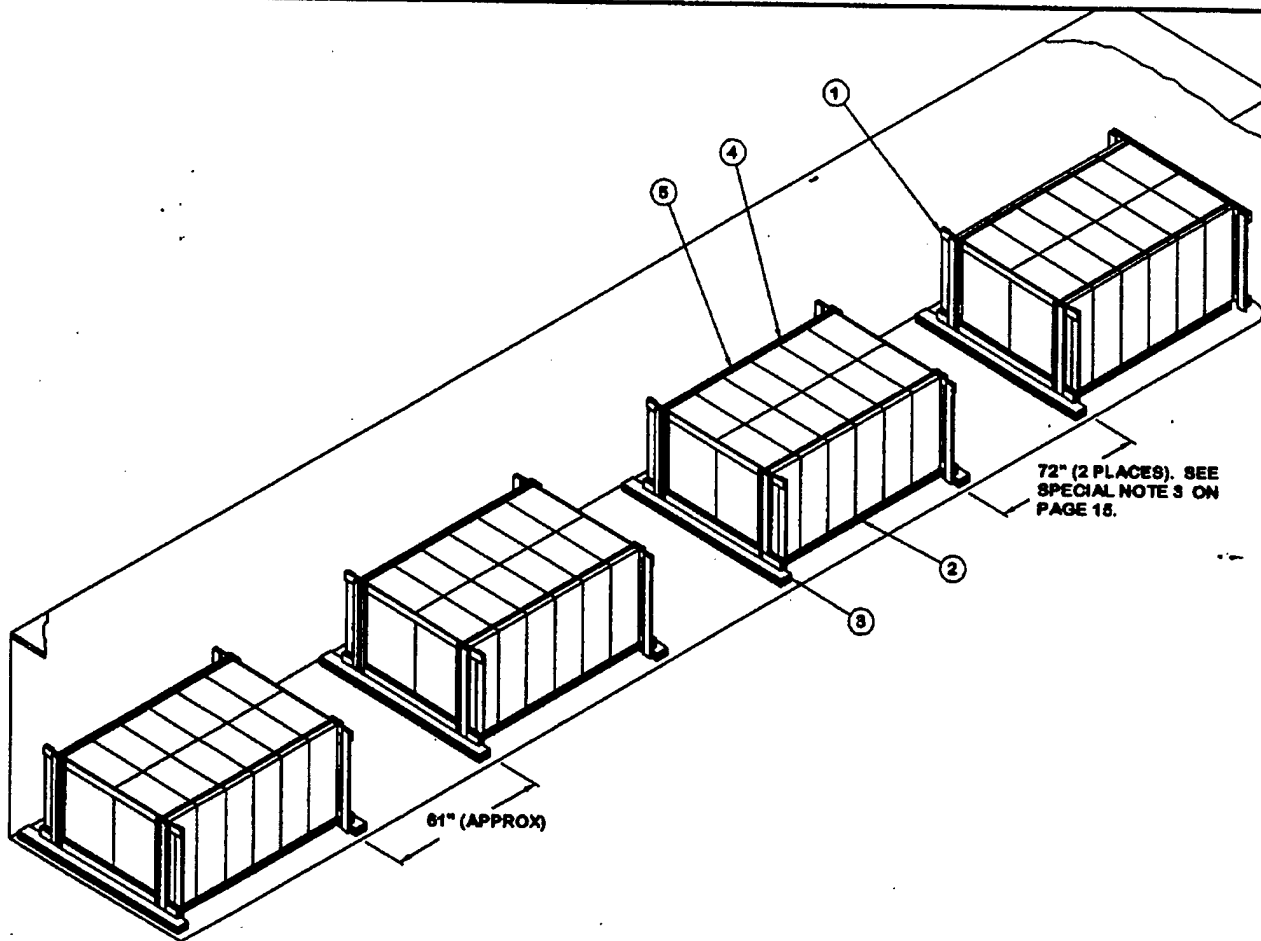

REAR OF TRAILER.

ISOMETRIC VIEW

KEY NUMBERS

- ① LOAD BEARING GATE (8 REQD). SEE THE DETAIL ON PAGE 44 AND GENERAL NOTE "N" ON PAGE 2. SEE SPECIAL NOTE 2 ON PAGE 15.
- ② SIDE BLOCKING, 2" X 6" X 7'-0" (DOUBLED) (8 REQD). PRE-POSITION AND NAIL THE FIRST PIECE TO THE TRAILER FLOOR W/8-10d NAIL EVERY 12". NAIL THE SECOND PIECE TO THE FIRST IN A LIKE MANNER.
- ③ END BLOCKING, 2" X 4" X 7'-0" (DOUBLED) (7 REQD). NAIL THE FIRST PIECE TO THE TRAILER FLOOR W/8-10d NAILS. NAIL THE SECOND PIECE TO THE FIRST W/8-20d NAILS.
- ④ UNITIZING STRAP, 1-1/4" X .035" OR .031" X 23'-0" LONG STEEL STRAPPING (8 REQD). INSTALL TO ENCIRCLE 8X PALLET UNITS AND TWO LOAD BEARING GATES, PIECES MARKED ①.
- ⑤ SEAL FOR 1-1/4" STRAPPING (16 REQD, 2 PER STRAP JOINT). SEE GENERAL NOTE "L" ON PAGE 2. DOUBLE CRIMP EACH SEAL.

SPECIAL NOTES:

1. A 48-UNIT LOAD OF 155MM PROJECTILES PALLETIZED 8 PER LARGE PALLET IS SHOWN IN A 48'-0" LONG BY 7'-6" WIDE (INSIDE DIMENSION) VAN TRAILER EQUIPPED WITH A NAILABLE FLOOR. TRAILERS OF OTHER DIMENSIONS CAN BE USED.
2. THE LOAD BEARING GATE, PIECE MARKED ①, WHICH IS POSITIONED AGAINST THE TRAILER FRONT WALL MUST HAVE FILL PIECES APPLIED TO BOTH THE UPPER AND LOWER HORIZONTAL PIECES.
3. DEPENDING UPON THE TYPE AND WEIGHT OF THE TRAILER BEING LOADED, AND THE WEIGHT OF THE TRACTOR TO BE USED FOR TRANSPORTING THE LOADED TRAILER, IT MAY BE NECESSARY TO ADJUST THE QUANTITY OF UNITS IN THE LOAD, OR TO SHIFT THE LOCATION OF THE LOAD PORTIONS IN ORDER TO COMPLY WITH THE WEIGHT DISTRIBUTION REQUIREMENTS.

BILL OF MATERIAL		
LUMBER	LINEAR FEET	BOARD FEET
1" X 4"	144	49
2" X 4"	144	96
2" X 6"	162	162
NAILS	NO. REQD	POUNDS
6d (2")	87	1/2
10d (3")	140	2
20d (4")	42	1-1/2
STEEL STRAPPING, 1-1/4" - 184' REQD	-----	26 LBS
SEAL FOR 1-1/4" STRAP	----- 16 REQD	3/4 LBS

LOAD AS SHOWN

ITEM	QUANTITY	WEIGHT (APPROX)
155MM, 8/PALLET	----- 48	41,952 LBS
DUNNAGE	-----	645 LBS
TOTAL WEIGHT		----- 42,597 LBS (APPROX)

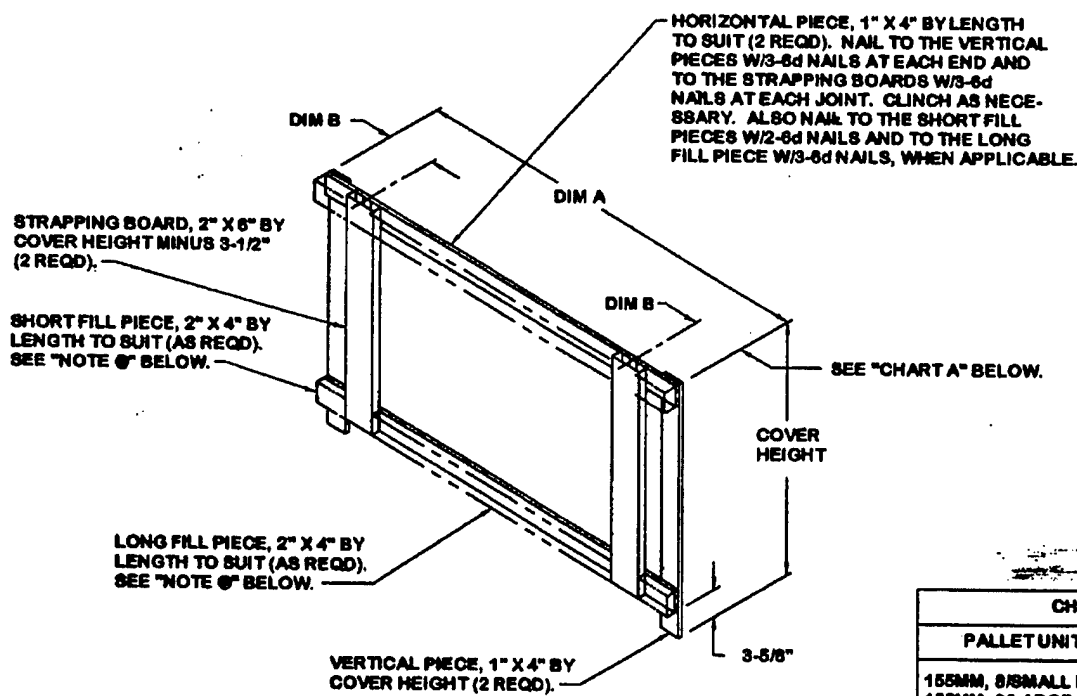

LOAD BEARING GATE

CHART A		
PALLET UNIT	DIM A	DIM B
155MM, 8/S SMALL PALLET	62"	8-1/2"
155MM, 8/LARGE PALLET	72"	8-1/2"
8", 3/PALLET	65"	6-1/2"
8", 6/S SMALL PALLET	65"	6-1/2"
8", 6/LARGE PALLET	67"	7"
8", 6/TALL PALLET	65"	6-1/2"

NOTE ①:

THE SHORT AND LONG FILL PIECES INDICATED BY PHANTOM LINES AT THE TOP AND NEAR THE BOTTOM OF THE LOAD BEARING GATE ARE REQUIRED ON GATES TO BE POSITIONED AGAINST THE TRAILER FRONT WALL. AT THE REAR OF A LOAD, THE SHORT AND LONG FILL PIECES ARE REQUIRED ONLY AT THE BOTTOM LEVEL. WHEN LOAD BEARING GATES ARE USED WITHIN A LOAD, THE REQUIREMENT FOR FILL PIECES WILL BE SPECIFIED IN THE SPECIAL NOTES SECTION WHICH IS IMMEDIATELY ADJACENT TO A DEPICTED LOAD.