

Development of a Data Acquisition System for Electrical Conductivity Images of Biological Tissues via Contactless Measurements

Tafseer Ahmad, Nevzat G. Gençer

Electrical and Electronics Eng. Dept.,
Middle East Technical University, 06531 Ankara, TURKEY

Abstract The data acquisition system of a new medical imaging system is developed and system performance is presented. The ultimate aim of the system is to image electrical conductivity of biological tissues via contactless measurements. Two different measurement systems are designed based upon measurement of impedance change of an eddy current type sensor. The first design (based upon excitation of a single coil probe) gives 100Hz output frequency change for a conductivity change of 1.9mS/cm and is tested at high frequency (1.4 MHz). Second design (based on one excitation and one receiving coil) operates at low frequency (15KHz) and gives 18 mV change in output voltage for similar conductivity variation. Field images of 30mm diameter cylindrical object were obtained while scanning a region of 225cm². The sensitivities of the two systems show a possible wide scale use of these systems for measurement, monitoring and imaging of local conductivity variations in biological tissues.

Key words: Biomedical Sensors, conductivity imaging

I. INTRODUCTION

The method of measuring electrical conductivity by inductive coupling has been used for decades for non-destructive testing [5]. In this technique currents are induced in the body using an excitation coil carrying time-varying (usually sinusoidal) current. The magnetic fields of the induced currents will be a function of the conductivity distribution and can be measured via magnetic sensors to reveal conductivity. The first application of this technique in the biomedical field was proposed by Tarjan and McFee [2]. In that study, a data acquisition system is developed using coils of 15cm diameter and average conductivity of human head and conductivity fluctuations in the human torso were measured. Gençer and Tek proposed the use of this technique for imaging purposes using smaller magnetic sensors and developed numerical models for image reconstruction [3-7]. In a previous study, Ahmad and Gençer reported the preliminary results of a prototype single and differential coil system [8]. The purpose of this study is to realize a portable measurement system based on these studies.

II. METHODS

Figure 1 shows the block diagram of the two measurement systems. First sensor and measurement system is designed at a frequency near 1.4 MHz. System consist of a sensor coil, sensor drive electronics and a signal-processing unit. Sensor coil, when driven by an alternating current, generates an oscillating magnetic field that induces eddy currents in any nearby conductive object. The eddy currents circulate in a direction opposite to that of the primary current in the coil due to which magnetic flux in the coil reduces. This causes a change in the inductance and the resistance of the coil, as the flow of eddy current dissipates certain amount of energy. Change in the conductivity of tissue changes the coupling and is reflected as an impedance change between the terminals of the coil. This is a function of input frequency, conductivity of object and the distance between object and the coil. In the first measurement system, we measured the impedance change of the coil due to conductivity variations at a fixed distance and frequency.

The measurement system with the first sensor type is shown in Fig. 2. An impedance to frequency converter is fabricated that is insensitive to stray capacitances. Circuit is an oscillator with two opamp inverters that produce a large positive voltage gain so that the circuit oscillates at a frequency where the phase shift is zero. The output is a square wave whose frequency is a function of conductivity of the object. This frequency output is connected directly to a parallel port of a computer to digitally linearize, offset and scale the output using constants stored during calibration. Furthermore, since all the sensor components are under calibration no costly, high precision instruments are required and the circuit operates from a single supply.

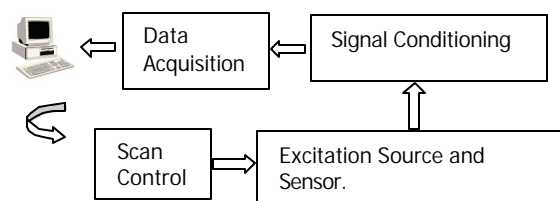

Fig. 1. Block diagram of the measurement systems

Report Documentation Page

Report Date 25OCT2001	Report Type N/A	Dates Covered (from... to) -
Title and Subtitle Development of a Data Acquisition System for Electrical Conductivity Images of Biological Tissues via Contactless Measurements	Contract Number	
	Grant Number	
	Program Element Number	
Author(s)	Project Number	
	Task Number	
	Work Unit Number	
Performing Organization Name(s) and Address(es) Electrical and Electronics Eng. Dept., Middle East Technical University, 06531 Ankara, TURKEY	Performing Organization Report Number	
Sponsoring/Monitoring Agency Name(s) and Address(es) US Army Research, Development & Standardization Group (UK) PSC 802 Box 15 FPO AE 09499-1500	Sponsor/Monitor's Acronym(s)	
	Sponsor/Monitor's Report Number(s)	
Distribution/Availability Statement Approved for public release, distribution unlimited		
Supplementary Notes Papers from the 23rd Annual International Conference of the IEEE Engineering in Medicine and Biology Society, October 25-28, 2001, held in Istanbul, Turkey. See also ADM001351 for entire conference on cd-rom., The original document contains color images.		
Abstract		
Subject Terms		
Report Classification unclassified	Classification of this page unclassified	
Classification of Abstract unclassified	Limitation of Abstract UU	
Number of Pages 4		

A limitation in the design of the measurement system is existence certain self-resonant frequency (SRF) due to the cable and coil inter winding capacitance and is given as

$$SRF = 1 / 2\pi \ L * (C_{cable} + C_{ciw})$$

This sets an upper limit for measurement frequency. The circuit of Fig. 4 oscillates at the resonant frequency given by

$$F (C) = RF = 1 / 2\pi \ L (C) * (C_{cable} + C_{ciw} + C_p)$$

Where L(C) is the coil inductance as a function of conductivity and C_p is the parallel resonant capacitance in oscillator circuit. A two-layer coil with 100 turn per layer with inductance of 110µH and inner and outer diameter of 10mm and 38mm is tested at minimum (unloaded) frequency of 1.468kHz. DC coil resistance is 4.5Ω. Coil is wound on a teflon core and the measuring circuitry is mounted near 60mm on vertical axis, safely above expected range to minimize the cable effects. Wire diameter was 0.28mm. A semicircular glass tube is mounted at a distance of 3mm from the coil, and saline solutions of different conductivities are passed at a constant rate of 0.5 ml/sec. All the arrangement was fixed by glue on the table to avoid errors due to vibration. Observations were taken in repeated intervals over the same conductive volume of 50ml. Frequency output was measured using BK precision function generator model 1850 with a sensitivity of 0.1 Hz.

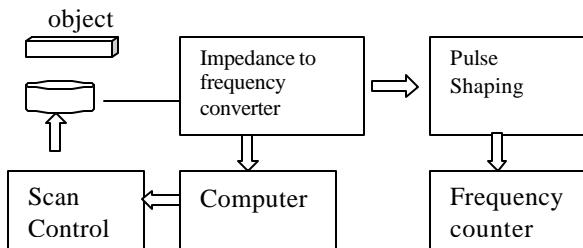
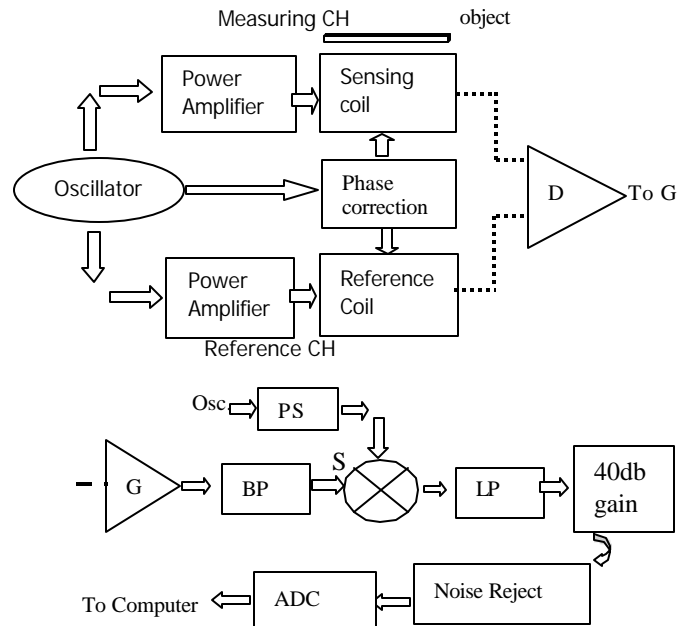

Fig. 2. Measurement system for one coil sensor

Fig. 3 shows the measurement system for the two-coil sensor. Two pairs of similar excitation and sensing coils are used that make the measuring and reference channels excited by two identical power amplifiers of very low total harmonic distortion (less than .01%). Gain correction is incorporated to minimize gain errors. Output from two channels is fed to a high precision differential amplifier with excellent matching of input resistor and having 200 volts common mode input voltage range. Output of the difference amplifier is zero in the absence of the conductive object. A phase and amplitude correction

network is added to minimise the errors caused by winding irregularities and harmonic distortion of two amplifiers. Output of difference amplifier is then fed to a phase sensitive detector circuit that can measure a signal as low as 0.1µV locked at reference input signal. A 0-360° phase splitter is added with reference input to lock the input at the desired phase. One advantage of using reference channel is cancellation of stray or environmental effects that will equally effect both measuring and reference coils. Further output change due to temperature rise in measuring coil will be equally canceled. Differential amplifier output is fed to multiple gain stages for different full scale sensitivity of output signal. Output is then fed to Synchronous Converter to obtain correlated output signal according to reference input signal at desired frequency and phase. An automatic noise correction network is added that adjust the baseline of measurement according to average fluctuation of field profile in absence of conductive object to obtain high-resolution images. This minimizes the need of any further processing of output signal in computer.



D: Diff. Amp, G: 20 db gain, S: Synchronous Converter, BP: Band Pass Filter, LP: Low Pass Filter, PS: Phase Splitter

Fig. 3. Measurement system for two-coil sensor.

III RESULTS

Figure 4 shows the results obtained from the single coil sensor, and this shows relative frequency change versus concentration of saline solution. Concentration was varied over 10g/l to 100g/l of salt water. Since normal tissue concentration is near 24g/l, this scans nearly half to 4 times the normal tissue concentration that is found in malignant body tissue. Change in frequency is near 6.5 kHz. Frequency output is non-linear with the impedance change. However, an empirically calculated mathematical function can be used to digitally linearize the output that resembles a simple exponential curve. Figure 4b gives the frequency change versus the distance of the conductive object. Again this change is highly non-linear as expected. Figure 4c shows the relative frequency output measured over a conductivity profile with a step conductivity jump at a certain position. Response of the sensor in these two figures shows its ability to discriminate a region of 10 times higher concentration when it is moved from position 4 to 8 in an array of tubes filled with saline solution.

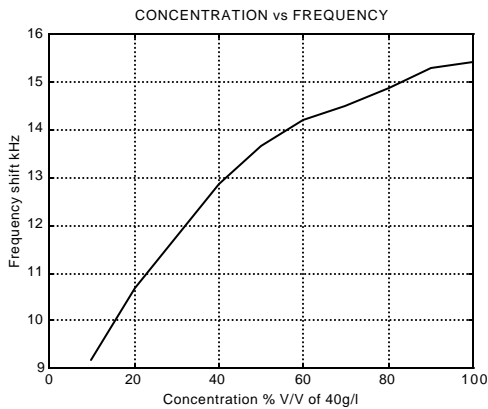

Fýg 4a. Output response of single coil sensor against conductivity variations.

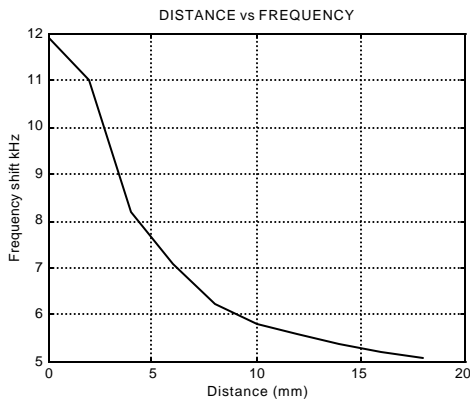

Fýg 6b. Output versus distance from the object response of single coil sensor against conductivity variations.

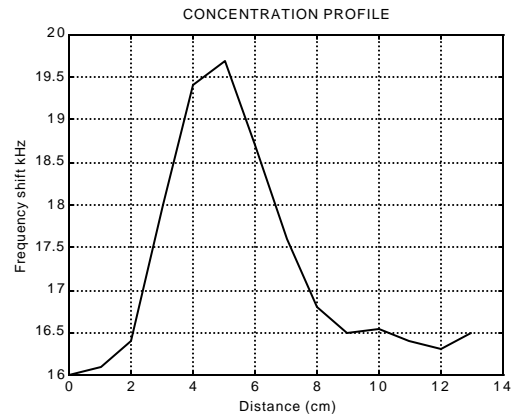

Fýg 4c. Conductivity profile measured with single coil sensor

Figure 5 shows the response of two-coil measurement system. A semi spherical object, containing 100gm/l of NaCl solution of coil dimension, was placed 2mm under the sensing coil. A 225cm² region was scanned with 32x32 data samples with object placed at the centre. Figure 7a shows the field profile and image of the object. It is possible to obtain even higher sensitivity with optimum coil configuration, higher frequency and higher excitation current but the system becomes prone to surrounding effects and stray capacitances of nearby objects.

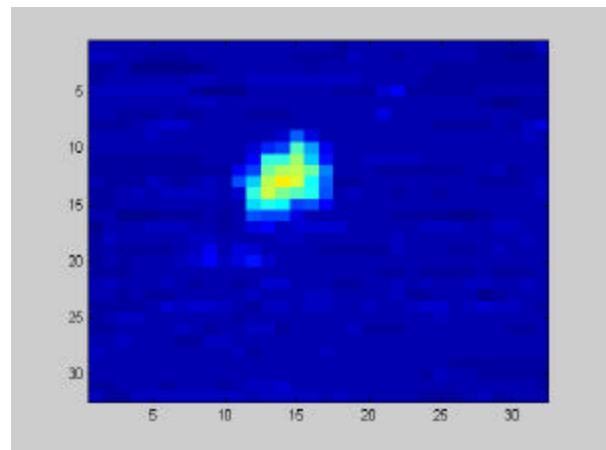

Fig. 5a. Field image of a conductive object scanned with two-coil sensor

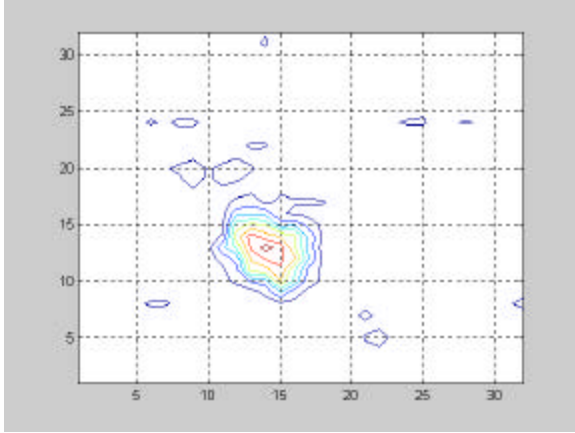

Fig 5b. Field profile of the conductive object

IV. CONCLUSION

Paper describes the measurement systems for single coil and double coil eddy current type sensors designed for sub-surface conductivity imaging of biological tissues. Major components of measurement system with specific characteristics and design procedure of sensors are detailed. Future work require a comprehensive study of layered half space conductive medium to practically measure the skin depth and to claim the validity of application for certain tissue thickness. An optimum design has to be worked out to obtain image in a phantom

of layered conductive medium. Variation in power supply current with conductivity change is to be monitored as small variation in supply current due to excessive current drawn from supply can cause measurement errors. Sensors have to be characterized for temperature variations and sensitivity.

V. REFERENCES

- [1] H. L. Libby, *Electromagnetic Non Destructive Testing*, Wiley-Interscience Ed. (1971).
- [2] P.P Tarjan, R Mc Fee, *Electrodless measurement of the effective resistivity of human torso by magnetic induction method*, IEEE trans. On biomedical Engineering, Vol BM-15, No.4 Ocotber 1968.
- [3] N. G. Gençer, M. N. Tek. "Electrical Conductivity Imaging via Contactless Measurements", *IEEE Trans. Med. Imag.*, 1999.
- [4] N. G. Gençer, M. N. Tek, *Forward Problem Solution for Electrical Conductivity Imaging via Contactless Measurement*, *Phys.Med.Bio.* 44(1999).
- [5] N. G. Gençer, M. N. Tek. "Electrical Conductivity Imaging via Contactless Measurements: A Feasibility Study", *ELEKTRIK*, 1999.
- [6] M. N. Tek *Electrical conductivity imaging via contact-less measurements. Forward and Inverse problem solution*, M.Sc. thesis. Middle East Technical University, 1998.
- [7] N. G. Gençer, M. Nejat Tek, "Sub-surface Electrical Conductivity Imaging via Contactless Measurements", 21th Annual International Conference of the IEEE Eng. Med. Biology Society, Atlanta, October 1999.
- [8] T. Ahmad, N.G Gençer "Experimental Studies on Development of A Sensor For Contactless Conductivity Imaging of Biological Tissues", National Biomedical Conf., November 2000, Istanbul.