

MEMORANDUM FOR PRS (In-House Publication)

FROM: PROI (STINFO)

30 Jan 2001

G-2
SUBJECT: Authorization for Release of Technical Information, Control Number: **AFRL-PR-ED-TP-2001-032**
Liu, C.T. and Smith, C.W., "Near Tip Behavior in a Particulate Composite Material Under Constant Strain Rate Including Temperature and Thickness Effects"

Presentation for International Conf. on Fracture 10
(Hawaii, 3-7 Dec 01) Deadline: 15 Feb 01

(Statement A)

NEAR TIP BEHAVIOR IN A PARTICULATE COMPOSITE MATERIAL UNDER CONSTANT STRAIN RATE INCLUDING TEMPERATURE AND THICKNESS EFFECTS

need to be hyperated? (Ref. section)

C. T. Liu
Air Force Research Laboratory
AFRRL/PRSM
10 E. Saturn Blvd.
Edwards AFB CA 93524-7680

C. W. Smith
ESM Department
Virginia Polytechnic Institute and State University
Blacksburg VA 24061

ABSTRACT

A series of tensile tests were conducted at a constant cross head speed (2.54 mm/min) and three temperatures (-53.9°C, 22.2°C, and 73.9°C) on edge cracked sheet specimens of two thicknesses (2.54 mm and 12.7 mm). The specimens were made from polybutadiene rubber embedded with hard particles. The effects of temperature and specimen thickness on local behavior and strain fields near the crack tip were investigated and the results are discussed.

INTRODUCTION

In recent years, a considerable amount of work has been done in studying crack growth behavior in highly filled polymeric materials⁽¹⁻⁴⁾. The importance of these studies stems from the fact that the crack growth behavior in the material may significantly affect the integrity of the structure made of that material. The basic approach used in characterizing the particulate composite material is based on linear elastic or linear viscoelastic fracture mechanics. According to the theories, crack growth behavior is controlled by the local stress/strain near the crack tip. Therefore, the values of local stress/strain near the crack tip must be determined. Since the highly filled polymeric materials behave like viscoelastic materials, the fracture behavior near the crack tip can be strongly influenced by the testing temperature and the loading rate. Therefore, to obtain a fundamental understanding of crack growth and fracture behavior in a highly filled polymeric material, the effect of the aforementioned parameters on local strain fields and fracture behavior near the crack tip need to be determined.

In the present study, the effect of testing temperature and specimen thickness on the local behavior near the crack tip and the crack growth behavior in the material were investigated and the results are discussed.

THE EXPERIMENTS

In this study, the local fracture behavior, the local strain fields near the crack tip, and the crack growth behavior in a particulate composite material, containing hard particles in a rubbery matrix, subjected to a constant strain rate of 0.1 min⁻¹ at different temperatures, were investigated. The specimens were 20.32 cm long and 5.08 cm wide (Fig. 1). Two different specimen thicknesses (2.54 mm and 12.7 mm) and three different temperatures (-53.9°C, 22.2°C, and 73.9°C) were considered. Prior to the test, a 25.4 cm crack was cut at the edge of

the specimen. Since the specimens were quite soft, a special grating had to be developed from which displacements near the crack tip could be measured without affecting the stiffness of the specimen. A coarse grating consisting of squares of 0.2 mm on each side (approximately $1/2$ of the largest size of the hard particle), and which had a thickness of less than 2.5×10^{-2} mm, was deposited in the neighborhood of the crack tip.

Suggest
Spelling
out =
"one-half"

Prior to testing, the specimens were conditioned at the test temperature for 1 hour and were then tested at a constant strain rate until the specimen fractured. During the tests, photographs of the grid region were taken at various time intervals, and they were used to determine the displacement fields near the crack tip. In addition, a strip chart recorder was used to record the load and time during the test. These data were used to determine the strain fields. In addition, a strip chart was used to record the load and time during the test. These data were used to determine the crack growth rate and the Mode I stress intensity factor.

Suggest
using next
transition
phrase such
as "Moreover"

DATA REDUCTION

The raw data obtained from the constant strain rate tests were the crack length, a , the time, t , and the load, p , corresponding to the measured crack length. The recorded experimental data, $a(t)$ and p , were used to calculate the Mode I stress intensity factor, K_I , and the crack growth rate, da/dt . In calculating the stress intensity factor, K_I , for a given set of values of a and p , a nonlinear regression equation (which relates the normalized stress intensity factor, K_I/p , to the crack length, a) was used. The values of K_I/p for different crack lengths were determined from the ABAQUS computer program. In calculating the crack growth rate, da/dt , the secant method was used. In the secant method, the crack growth rate was computed by calculating the slope of a straight line connecting two adjacent a versus t data points. To avoid the time-consuming process of data reduction, a computer program was written to calculate K_I and da/dt . In addition, the displacements and the strain fields were determined by digitizing the data from the photographs. In calculating the strains, small strain definitions were used. Therefore, strain contours for strain level greater than 20% should be ignored.

= space needed

RESULTS AND DISCUSSION

All curves in this section were constructed from averaging data of two tests. Figures 2 and 3 show the load per unit thickness as a function of global strain for thin and thick specimens tested at 73.9°C and -53.9°C (results at 22.2°C were similar to 73.9°C). Figure 2 shows that at 73.9°C , the load carrying ability for the thin specimen is consistently higher than the thick specimen. However, at -65°F , the trend is reversed, which suggests that some change in material properties had occurred before reaching this temperature. The increase in maximum load per unit thickness of the thin specimen above the thick ones at 73.9°C may be attributed to the size effect and the damage initiation and evolution processes near the crack tip. At 73.9°C , the binder material softened to the point where it would support only small stress before the ligaments between the voids in the failure process zone ruptured. Also, the thermal energy facilitates interchain sliding, allowing the ligaments to thin more rapidly and rupture under lower tensile stress. Additionally, at elevated temperature, the bond strength at the particle/binder interface is decreased. This leads to a larger failure process zone and crack opening distance at the crack tip. However, at -53.9°C , the bond strength and the binder strength increase significantly. Also, it was noted that at -53.9°C , blunting was significantly reduced and classical brittle fractures occurred in these tests with the crack propagating

Suggest
italicizing
symbols in
order to
distinguish
on rest of
ext -
Apply throughout
this paper

- or C
②

unstably across the specimens. The reduction of crack tip blunting suggests that voiding is suppressed due to the stiffening effect of the low temperature on the matrix material. This is believed to have allowed the development of transverse constraint in the thick specimens at 53.9°C and causes the material to behave almost as a single phase material. Also, the development of transverse constraint at -53.9°C will decrease the material's ability to redistribute stresses and result in a greater load per unit thickness in the thick specimen than in the thin specimen.

should be connected with temper

to be consistent w/ previous figs... rather?

Typical near-tip displacement contours are shown in Fig. 4. From Fig. 4, the regularity of the displacement field suggests that this material may be described by continuum theory. In addition, the order of singularity at the crack tip when the crack intersects the free surface of the specimen was also investigated. According to fracture mechanics, the stresses and displacements in the neighborhood of the crack tip can be expressed as

$$\sigma_{ij} = \gamma^{\lambda_u} f_{ij}(\lambda, \theta, \phi), \quad u_{ij} = \gamma^{\lambda_u} (\lambda, \theta, \phi).$$

By confining displacement measurements to a region outside the highly voided failure process zone ahead of the crack tip, it was possible to measure the value of the dominant eigenvalue λ_u at the free surface using a continuum approach. Results of analyses show that the average value of $\lambda_u = 0.72$ agrees within 7.5% with the theoretical value predicted by Benthem for incompressible materials, $\lambda_u = 0.67$. The small differences between the measured and the calculated λ_u indicates that, even though the particulate composite material is anisotropic and heterogeneous on the micro scale, it may behave as an isotropic, homogeneous continuum when analyzed macroscopically.

sp
2 page
4

Typical plots of normal strain fields, ϵ_x , for different specimen thicknesses and temperatures are shown in Fig. 5. In general, these figures show that the contour lines are not smooth but irregular. It is believed that a portion of the irregularities may stem from the method of data collection and reduction, but they are mainly due to the nonhomogeneity of the material. The experimental data indicate that, for a given temperature, specimen thickness has no significant effect on the strain distributions near the crack tip. Experimental data also indicates that large normal strains occur in small zones, or the intense strain zones, which are immediately ahead of the crack tip. It seems that the intense strain zone size ^{appears} is relatively insensitive to the change in specimen thickness and it decreases with decreasing testing temperature. Since the intense strain zone is very small, as compared with the crack length and the dimensions of the specimen, linear fracture mechanics theories can be used to characterize crack growth behavior in the material.

The crack growth rate da/dt versus the Mode I stress intensity factor K_I are shown in Figs. 6 and 7. From these figures, it can be seen that a power law relationship exists between K_I and da/dt . Mathematically, it can be written as

$$da/dt = c K_I^B$$

in which c and B are constants. Figures 6 and 7 also reveal that the crack growth is much faster at -53.9°C.

↑
spacing

CONCLUSIONS

The principal conclusions which can be derived from the results of this study are: (1) the local behavior near the crack tip and the crack growth behavior at -53.9°C are significantly different from ^{those} that at 22.2°C and 73.9°C ; (2) the crack growth data reveal that a ductile-brittle transition occurs somewhere between -53.9°C and 22.2°C ; (3) except the thicker specimen tested at -53.9°C , the near tip mechanisms (blunting, voiding, coalescing, and growing) differ only in a quantitative sense; (4) a classical brittle fracture takes place when the thicker specimen tested at -53.9°C ; (5) on a macro scale, the particulate composite material can be considered as a homogeneous continuum; and (6) a power relationship exists between the crack growth rate and the Mode I stress intensity factor.

REFERENCES

1. Liu, C.T., 1990. "Crack Growth Behavior in a Composite Propellant with Strain Gradients - Part II," *Journal of Spacecraft and Rockets*, 27: 647-659.
2. Smith, C.W. and Liu, C. T., 1991. "Effects of Near-Tip Behavior of Particulate Composites on Classical Concepts," *Journal of Composites Engineering*, 1, 4: 249-256.
3. Liu, C. T., 1993. "Investigating the Near-Tip Behavior and Damage Characteristics in a Particulate Composite Material," *ASTM-STP-1189*: 668-679.
4. Smith, C. W., Wang, L., Mouille, H., and Liu, C. T., 1993. "Near-Tip Behavior of Particulate Composite Material Containing Cracks at Ambient and Elevated Temperatures," *ASTM-STP-1189*: 775-787.

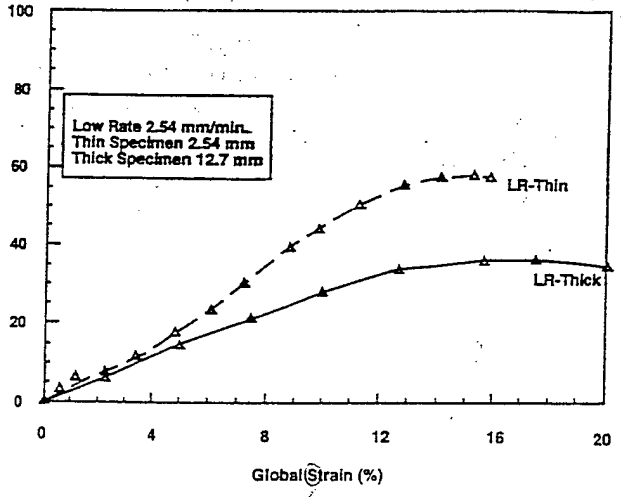
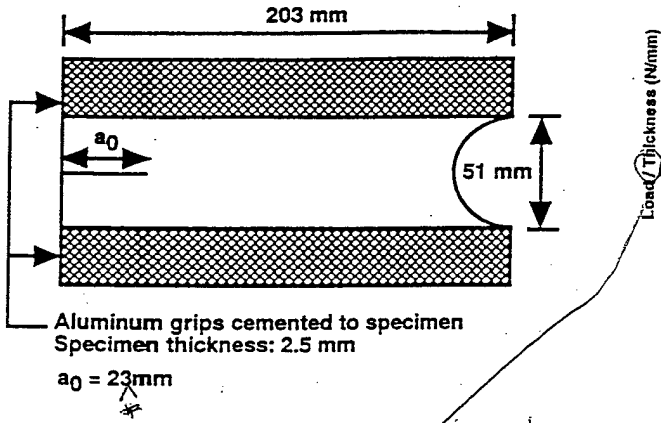

Fig. 2 Load-strain relations ($T=73.9^{\circ}\text{C}$)

Suggest Spelling out "Figure"

Fig. 1 Specimen geometry

please be consistent

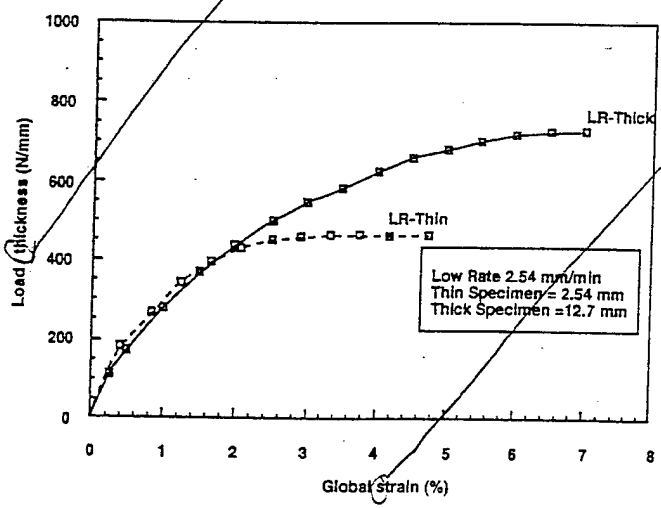

Fig. 3 Load-strain relations ($T=-53.9^{\circ}\text{C}$)

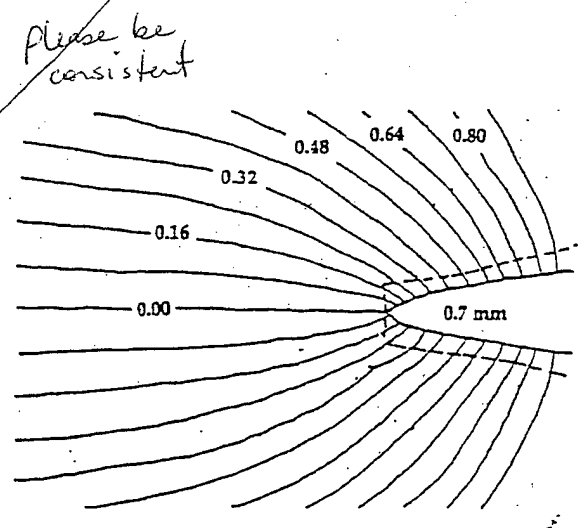
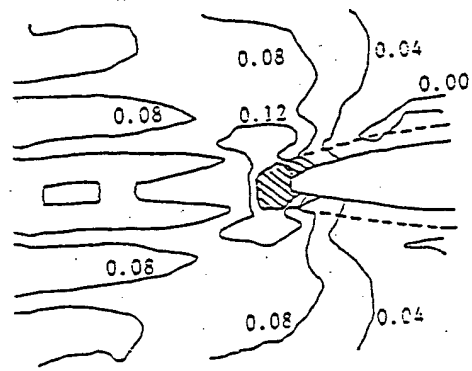

Fig. 4 Typical contour plots of normal displacement ($T=-53.9^{\circ}\text{C}$, $t=2.54$ mm)

* Suggest more spacing between number and text of caption

* Also, if you do spell out "Figure"
→ "Figure 1. Specimen Geometry"



(a) Thickness = 2.54 mm

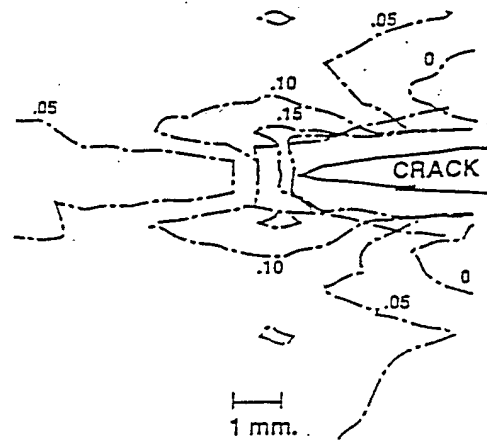

(b) Thickness = 12.7 mm

Fig. 5 Typical contour plots of normal strain ($T = -53.9^\circ\text{C}$)

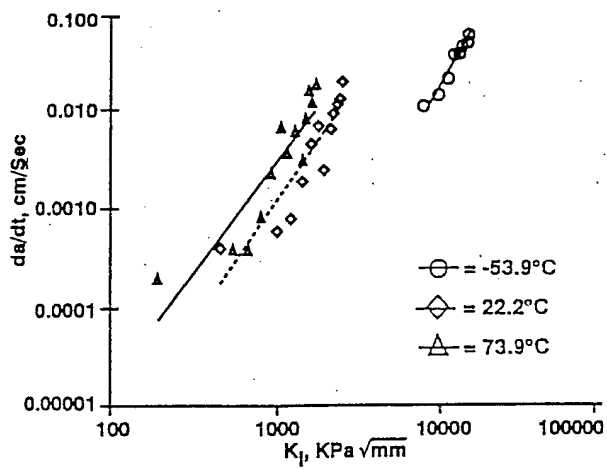

Fig. 6 Crack growth rate versus Mode I stress intensity factor ($t=2.54\text{mm}$)

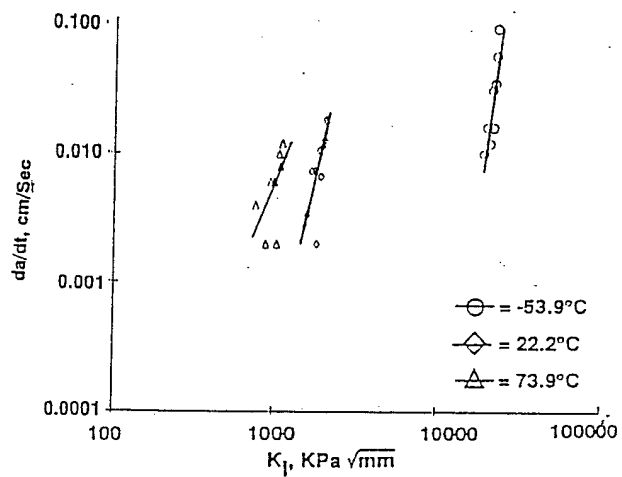

Fig. 7 Crack growth rate versus Mode I stress intensity Factor ($t=12.7\text{mm}$)