

INTERACTIVE MEDICAL VOLUME VISUALIZATION FOR SURGICAL OPERATIONS

A. Özkurt, K. Özmehmet

Department of Electrical and Electronics Engineering, Dokuz Eylül University, IZMIR, TURKEY

Abstract—In this paper, a “Surgeon Assistant System” using Enhanced Reality (ER) approach is presented. The main idea is to use Virtual Reality (VR) device(s), and assist the surgeon with one and two-dimensional information of human body and three-dimensional volumetric surface models of anatomic tissues, especially in the brain operations. This opportunity may increase the concentration of the surgeon with the combinational use of real and computer generated information combination. Therefore, increased concentration and well-organized information improve the success rate of the surgery. This study covers hardware and software implementation of a prototype system recommending requirements of such tools.

Keywords – Computer Aided Surgery (CAS), Enhanced Reality.

I. INTRODUCTION

Surgery is a treatment method for some abnormal structures in any organ, tumor and deformations. These illnesses can be replaced or corrected in the surgeries. All surgeries have risks about the health of the patient depending on the organ and the type of operation; therefore high concentration and care are required. In traditional procedures, a surgeon has to prepare thoroughly for the operation. Although operation rooms are very complex areas because of the need for various high technology equipments, the success of the operation depends primarily on the performance of the surgeon. The surgeons of today, as in the past rely primarily on hand-eye coordination for performing various procedures. The surgeons generally complain from restricted field of view, lack of contrast between target and surrounding tissues and inability to see beneath the surface [1]. Computer Assisted Surgery (CAS) systems can solve these problems using high-resolution imaging and detailed anatomical information combination. The surgeon's vision can be extended by the use of MRI and CT, two powerful imaging technologies which can penetrate beneath the surface and provide an image of the human body in three dimensions [2]. Using computerized reconstruction and image processing techniques/images can be provided in a form in which the surgeon, using an interactive computer workstation, can navigate through the simulated organs without cutting, and can plan and rehearse surgical procedures. Three-dimensional reconstructions of imaging data can also be used for real-time control during the performance of surgical procedures or other therapeutical interventions [3].

Our approach shown in Fig 1. Is based on the Enhanced Reality methodology to assist the surgeon with the combination of real video and computer generated two dimensional slice views and three dimensional surface models of the organs in the education, planning and intra-operative phases of the surgeries.

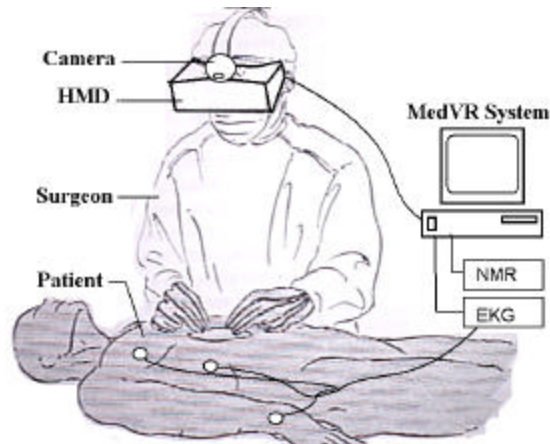

Fig. 1. Basic Enhanced Reality Approach for CAS Applications
Revised From Reference [4].

The main goal in this study is to increase the concentration and compactness of the information of the surgeon and increase the success rate of the operation. This may help to improve the human health.

II. METHOD

Our Method requires hardware and software implementation of previously stored volumetric data and realtime acquired information. Therefore, the system includes several main sections shown in Fig 2: Data Acquisition, Data Manipulation, Visualization and Medical Implementation.

1) **Data**: The system can process one dimensional vital signs from human body such as temperature, blood pressure acquired from patient monitor, two dimensional slice views of NMR and CT images (slice), and three dimensional arranged NMR and CT volumes. This volumetric information can be acquired slice by slice using fast equipment. We have different slice sized and different slice numbered information. These properties can be changed regarding to operation area and operation sensitivity. For example, brain surgeries need maximum detail, so the number of slices must be the highest.

2) **Data Manipulation**: In this study, the main idea is to use volumetric surface models of the medical tissues with the real data, because, direct renderings of volumes do not give efficient information about the anatomy and require much processing resources. Thus, we have to process raw data in order to reconstruct a surface model of the volume of interest (VOI) and make visualization phase easier and faster. The processing phase must have three steps: **Preprocessing** step for data conditioning, **Processing** step for **NMR Segmentation** and **3D surface Reconstruction** from previously processed and segmented data.

Report Documentation Page

Report Date 15 Oct 2001	Report Type N/A	Dates Covered (from... to) -
Title and Subtitle Interactive Medical Volume Visualization for Surgical Operations	Contract Number	
	Grant Number	
	Program Element Number	
Author(s)	Project Number	
	Task Number	
	Work Unit Number	
Performing Organization Name(s) and Address(es) Department of Electrical and Electronics Engineering Dokuz Eylul University IZMIR, Turkey	Performing Organization Report Number	
Sponsoring/Monitoring Agency Name(s) and Address(es) US Army Research, Development & Standardization Group (UK) PSC 802 Box 15 FPO AE 09499-1500	Sponsor/Monitor's Acronym(s)	
	Sponsor/Monitor's Report Number(s)	
Distribution/Availability Statement Approved for public release, distribution unlimited		
Supplementary Notes Papers from 23rd Annual International Conference of the IEEE Engineering in Medicine and Biology Society, October 25-28, 2001, held in Istanbul, Turkey. See also ADM001351 for entire conference on cd-rom., The original document contains color images.		
Abstract		
Subject Terms		
Report Classification unclassified	Classification of this page unclassified	
Classification of Abstract unclassified	Limitation of Abstract UU	
Number of Pages 4		

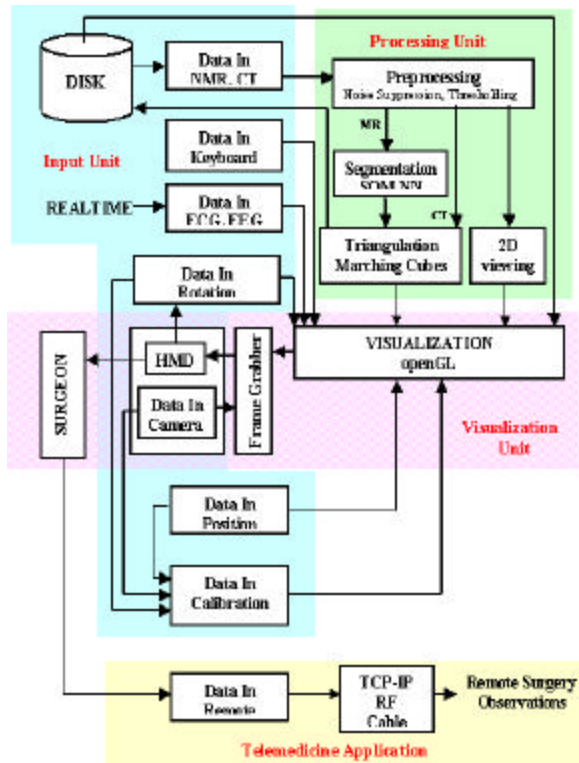

Fig. 2. Basic Block Diagram for Suggested and Implemented System [5].

In preprocessing step, various fundamental image processing algorithms are performed. For example, slice data has a background and noise which must be cancelled. By using a thresholding scheme, interested tissues can be recovered easily. For a CT image, thresholding is sufficient to differ bony media from soft tissues, but, for an NMR slice, this type of basic operation is not capable of classifying all brain tissues. So, an advanced segmentation scheme must be applied to NMR data. Before segmentation, we had required a normalization of data for standard processing routine. For that purpose, we have applied contrast normalization via histogram equalization and tone normalization by using converting all volumetric data to 8 bit boundaries from 12 or 16 bit data depths.

NMR segmentation plays an important role in our work, because, classifying brain tissues from NMR slices requires an automatic segmentation scheme. Although, some studies are announced as automatic segmentation method [6], [7], [8], no method is capable of fully automatic segmentation process, because every method is limited with the data acquisition method, biological structure and modality. So, we had to develop a segmentation process for our system.

Several approaches for MRI segmentation are seen in the literature. These are traditional spatial methods based on region growing and edge detection [9], statistical Methods [10] use statistical properties of tissues, neural methods [11], [6], [8] and fuzzy methods. At the same time, combined approaches are developed to bring together advantages of several segmentation methods in order to obtain finest results. Our approach is developed with this aim. We have developed a neural method which uses spatial and statistical

properties of medical tissues for performing segmentation of brain structures.

Our segmentation process uses Self Organizing Feature Maps (SOFM) [12]. In SOM, on the contrary to Feedback and feedforward neural networks, neighboring cells in a neural network compete in their activities by means of mutual lateral interactions, and develop adaptively into specific vectors of different signal patterns. In this category learning is called competitive, unsupervised or self-organizing. This property makes this method the most proper approach for automatic segmentation, because, supervising phase goes shorter or is consisting of efforts on only labeling tissues from trained network.

During the study we have tried different map sizes and features to train and test the network. 5x5 to 10x10 map sizes are used. The best results are obtained by using 7x7 rectangular map. For train and testing phases, 38 different features, which are spatial and statistical, were applied to our network. Spatial features are position, index tone, index neighbourhood tones, neighbourhood gradient, 5x5 window average. Statistical features given below are Energy, Momentum and Entropy [13] properties of selected index window. These properties are related to texture on the image. For example, entropy is directly related to amount of changes in our texture. Homogenous images give low entropy values. Thus, NMR image, which is seen as textured structure, can be understood differently.

$$\text{Energy} = \sum_i \sum_j M_d^2(i, j) \quad (1)$$

$$\text{Momentum} = \sum_i \sum_j (i - j)^2 M_d(i, j) \quad (2)$$

$$\text{Entropy} = \sum_i \sum_j M_d(i, j) \ln M_d(i, j) \quad (3)$$

Where $M_d(i, j)$ is Cooccurrence Matrix of selected window.

After the preprocessing and processing stages, related medical brain tissues, which are skull, white matter, gray matter and pathology (tumor), are segmented and prepared for modeling.

Modeling phase consists of isosurface extraction method based on finding discontinuities over an iso valued volume and determination of surface patches (triangles or tetrahedras) coating closed media having almost the same iso value.

For extraction of isosurfaces, two main algorithms are available: Marching Cubes [14] and Delaunay Triangulation. Marching cubes algorithm has a relatively easier implementation procedure than Delaunay Triangulation. Delaunay triangulation is based on voronoi diagrams and requires complex computations. Thus, we have performed Marching Cubes Algorithm because of their easier implementation and high speed.

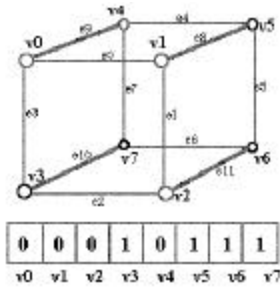
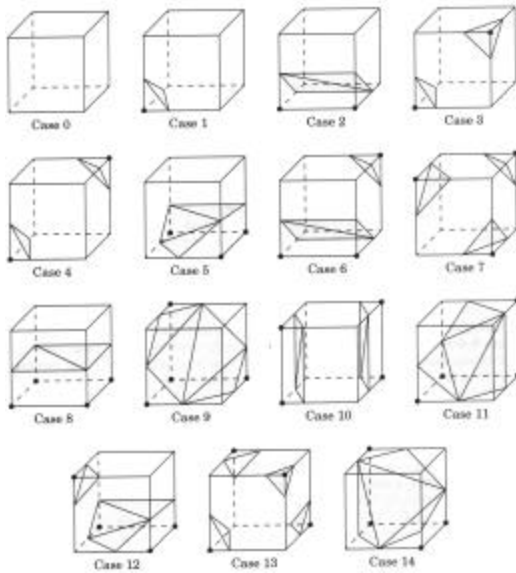

Fig. 3. Fundamental Cube Arrangement for Marching Cubes Algorithm.

Fig. 4. 15 Fundamental Cases of possible 256 of Marching Cubes



Marching Cubes Algorithm is a divide and conquer algorithm, uses two main lookup tables and decides which surfaces patches are convenient for selected cube arrangement as shown in Fig.3. There are 256 different arrangement possibilities for any selected unit cube. By using symmetry, these are eliminated to 15 cases given in Fig.4.

3) **Visualization:** Segmented and modeled three dimensional information is ready to be displayed in a three dimensional viewport. In order to increase the speed of the vision and make our visualization scheme platform independent, we have used OpenGL graphics library. This direct interface to graphics hardware provides an efficient interactive manipulation of our models. The user can navigate through the virtual world, rotate, zoom and cut the model.

Second operation in visualization section is **video overlay method**. Combination of virtual world and real running video is realized by special hardware, a frame grabber with the function key overlay. Doing this operation by hardware prevents the computation power lacks during operation. Thus, all computation efforts can be focused on interactive display options. Video overlay method is shown in Fig.5.

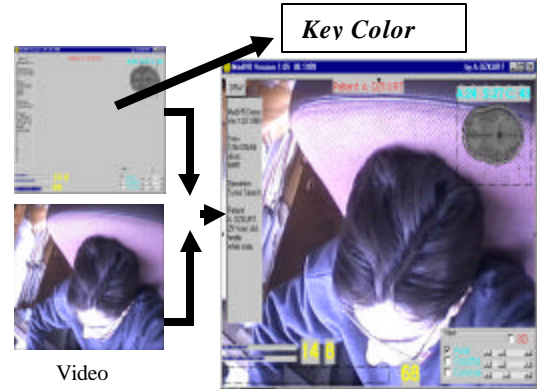

Fig. 5. Video Overlay Method

III. RESULTS

During the study, much effort has been spent on MRI segmentation, three-dimensional surface modeling of brain tissues and interactive visualization of models on real video. Fig.6 shows examples of the results of segmentation phase. After segmentation, synthetic surface patches for example unit cube and reconstructed surface of human brain white matter can be seen in Fig.7.

During the surgery, our system provides three types of information. One of which is one-dimensional vital signs from human body such as temperature and ECG information. This information can be supplied by a conventional hardware and it can be monitored real-time on the HMD in order to recover any changes of the patient. The second information is two dimensional slice views of the NMR and CT data. The surgeon may need any cross section of the body in the operation. Fig.8 shows one and two dimensional data monitoring on real video in our system.

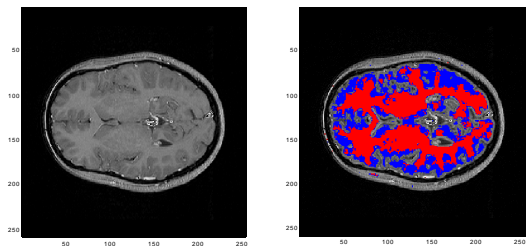

Fig.6. Segmentation Result for White and Gray Matter

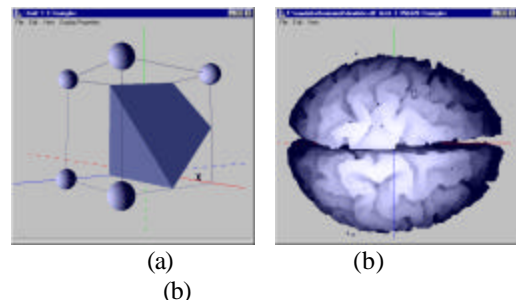

Fig. 7. (a) Generated Surface Patches for Example Unit Cube, (b) Reconstructed Human Brain White Matter

The most important display content in this work is three-dimensional surface model overlay procedure. This opportunity differs our work from conventional surgery assistance methods. Usage of three dimensional views of the media and manipulation interactively gives maximum accuracy. Navigation fly-through and marking options may be helpful for the success of the surgery. Three-dimensional model overlay option used in the operation is given as Fig.9.

IV. CONCLUSION

This method for surgery assistance is to reconstruct a three dimensional surface models of the medical tissues and display these renderings and other one- and two-dimensional conventional information on an HMD (Head Mounted Display) which is mounted on the surgeon's head. This possibility introduces the maximum benefits of a surgery assistance system by using real-time interactive information support

In this study, a surgery planning, education and surgery assistance system has been developed. The approach is Enhanced Reality (ER), donated by an HMD and a camera, and the combination of real world and real data. The system was evaluated for the brain operations, but, it can be used for any surgery of any area of human body.

Such systems can be used for educative purposes without any doubt for student and the patient. Studying computer models and performing virtual surgeries improves the experience required for a surgeon. Also this type of assistance may increase the concentration of the surgeon during the surgery and may cause improvements of the success rate. Therefore, we may prevent possible failures.

Comments given for this system by the surgeons indicate that this system may be useful in surgical actions. Some of the operators believe that this system is a new patient monitor and a surgery assistance tool.

Our system will be our first step to telemedicine. In the future, this system may be used to share surgical data, including patient vital signs and surgeon's treatment, therefore it could be possible to realize the surgeries with the help of remote experts consultancy.



Fig.8 (a) One and two Diemnsional Information assistance

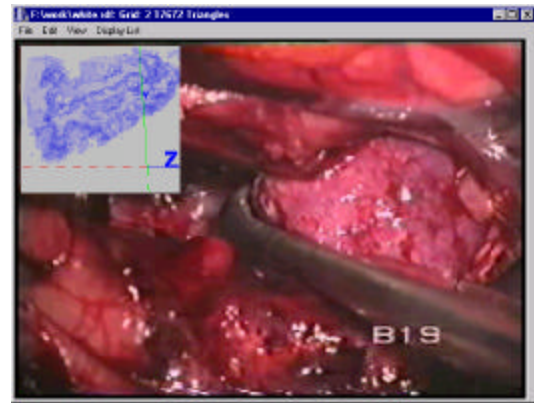

Fig.9 Three-Dimensional View of Computer Generated Transparent Model and Video Overlay Operation

REFERENCES

- [1] R. Kikinis, "Virtual Reality in MRI", *Inter. Conf. Proc. Combined Volumes*, 1994, pp.629-631.
- [2] S. Tang, C. Kwok, M. Teo, N.W. Sing, K. Ling, "Augmented Reality Systems for Medical Applications", *IEEE Engineering Medicine and Biology*, 1998, pp.49-58.
- [3] R. Kikinis, F.A. Jolesz, H.A. Cline, W.E. Lorensen, G. Gerig, "The Potential use of MRI Guidance for Computerized Surgical Procedures", *Annual International Conference of the IEEE Engineering and Medicine and Biology Society*, 1991, Vol:13, No:1, pp. 0303-304.
- [4] J.M. Rosen, H. Soltanian, R.J. Redett, D.R. Laub, "Evolution of Virtual Reality: From Planning to Performing Surgery", *IEEE Engineering in Medicine and Biology*, March/April 1996, pp.16-22.
- [5] A. Özkurt, "Interactive Medical Volume visualization for Surgical Operations", *Phd Thesis*, February 2001, Izmir, Turkey, p 60.
- [6] M. N. Ahmed, A.A. Farag, "3D Segmentation and Labeling Using Unsupervised Clustering for Volumetric Measurements on Brain CT Imaging" *ANNIE'96, Artificial Neural Networks in Engineering*, 1996, pp.1-15.
- [7] M. S. Atkins, T. Mackiewicz, Fully Automatic Segmentation of the Brain in MRI" *IEEE Trans. on Medical Imaging*, 1998, Vol:17, No:1, pp. 98-107.
- [8] N. Shareef, D. L. Wang, R. Yagel, "Segmentation of Medical Images Using LEGION", *IEEE Trans. on Medical Imaging*, 1999, Vol:18, No:1, pp. 74-91.
- [9] M. Clark, L.O. Hall, D.B. Goldgot, L.P. Clarle, R.P. Velthuisen, M.S. Silbiger, *MRI Segmentation Using Fuzzy Clustering Techniques*, *IEEE Engineering in Medicine and Biology*, November/December 1994, 730-733
- [10] K. Held, E.R. Kops, B Krause, W.M. Wells, R. Kikinis, H. Muller-Gartner, *Markov Random Field Segmentation of Brain Images*, *IEEE Trans. on Medical Imaging*, Vol:16,no:6, 1997, pp. 878-886
- [11] E. Gelenbe, Y. Feng, K. Ranga, R. Krishnan, *Neural Networks for Volumetric MR Imaging of the Brain*, *Int. Workshop on Neural Networks for Identification, Control, Robotics and Signal/Image Proc. (NICROSP'96)*, 1996, pp.194-202
- [12] T. Kohonen, *The Self-organizing Map*, *Proceedings of the IEEE*, Vol:78, No:9, 1990, pp.1464-1480.
- [13] T. Kohonen, *Self-organizing Maps*, Springer 1997.
- [14] W.E. Lorensen, H.E. Cline, *Marching Cubes: A High Resolution 3D Surface Reconstruction Algorithm*, *Proc. of SIGGRAPH'87 Computer Graphics*, Vol:21, No:4, 1987, pp.163-169.