



MEMORANDUM FOR PRS (In-House/Contractor Publication)

FROM: PROI (STINFO)

01 Mar 2001

SUBJECT: Authorization for Release of Technical Information, Control Number: **AFRL-PR-ED-TP-2001-043**  
Liu, C.T., "Investigating Near Tip Damage and Crack Growth Behavior in a Solid Propellant"

**JANNAF 34<sup>th</sup> Structures & Mechanical Behavior Subcommittee Meeting**  
**(Cocoa Beach, FL, 26-30 Mar 2001) (Deadline: 09 Mar 2001)**

**(Statement A)**

# Investigating Near-Tip Damage and Crack Growth Behavior in a Solid Propellant

C.T.Liu  
AFRL/PRSM  
10 E. Saturn Blvd.  
Edwards AFB CA 93524-7680

## Abstract

In this study, the local damage mechanisms near the crack tip in a solid propellant under a constant strain rate was investigated, using biaxial strip specimens. The effect of local damage on crack growth behavior was also investigated, and the results are discussed.

## Introduction

When cracks occur, whether resulting from the manufacturing process or from service loads, the stresses near the crack tip will be redistributed according to nonlinear material behavior. Depending on the magnitude of the local stresses and the local strength, various defects, microvoids or microcracks, can develop in the crack tip region. And, depending on the severity of these defects, crack growth behavior can be significantly affected. Therefore, to obtain a fundamental understanding of crack growth behavior in particulate composite materials, the effect of the defect on local fracture behavior near the crack tip needs to be determined.

In recent years, a considerable amount of work has been done studying crack growth behavior in particulate composite materials (1-4). This work was based on linear fracture mechanics. The principles of classical fracture mechanics are well established for single-phase materials. However, experimental evidence indicates that linear fracture mechanics theories have been applied to particulate composite materials with varying degrees of success.

In this study, pre-cracked specimens were used to study local damage near the crack tip and crack growth behavior in a solid propellant under a constant strain rate at room temperature. The local damage state and its effect on crack growth behavior were investigated and the results were discussed.

## The Experiments

In this study, the local fracture behavior, the local strain fields near the crack tip, and the crack growth behavior in a solid propellant specimen subjected to a constant strain rate of  $0.5 \text{ min}^{-1}$  were investigated. The specimens were 203 mm long, 51 mm wide, and 2.5 mm thick (Fig.1). Prior to the test, a 23 mm crack was cut at the edge of the specimen. Prior to testing, the specimens were conditioned at the test temperature for 1 hour and were then tested at a constant strain rate until the specimen fractured. During the tests, a video camera was used to monitor crack growth. In addition, a strip chart recorder was used to record the load and time during the test. These data were used to determine the crack growth rate.

## Data Reduction

In order to investigate the effect of pre-existing damage on the crack growth behavior in the particulate composite material, the crack growth rates  $da/dt$  as a function of time were calculated. In calculating  $da/dt$ , the secant method was used. In the secant method, the crack growth rate was computed by calculating the slope of a straight line connecting two adjacent  $a$  versus  $t$  data points. The calculated average crack growth rate was assigned at a point midway between each pair of data points.

## Results and Discussion

It is well known that, on the microscopic scale, a highly filled polymeric material can be considered an inhomogeneous material. When these materials are stretched, the different sizes and distribution of filled particles, the different crosslink density of polymeric chains, and the variation in bond strength between the particles and the binder can produce highly nonhomogeneous local stress and strength fields. Depending on the magnitude of the local stress and the local strength, damage can be developed in the material, especially near the crack tip region. The damage developed in the material may be in the form of microvoids or microcracks in the binder or dewetting between the binder and the filler particles. Damage growth in the material may occur as material tearing or as successive nucleation and coalescence of the microcracks. These damage processes are time dependent and are the main factor responsible for the time sensitivity of strength degradation as well as the fracture behavior of the material. Therefore, obtaining a better understanding of crack growth behavior requires detailed knowledge of damage mechanisms in the crack tip region.

A sequence of photographs showing the crack surface during the earlier stage of crack growth is shown in Fig. 2. Experimental results indicate that crack tip blunting takes place both before and after crack growth. The material at the tip of the crack suffers very large elongation and is nearly straight. The highly strained or damage zones extends ahead of the crack tip, appearing as an equilateral triangle with the crack tip as its base. This damage zone is known as the failure process zone, which is a key parameter in viscoelastic fracture mechanics (5-6). When the local strain reaches a critical value, small voids are generated in the failure process zone. Due to the random nature of the microstructure, the first void is not restricted to the surface where the maximum normal strain occurs. Since the tendency of the filler particle to separate from the binder under a triaxial loading condition is high, it is expected that voids, or a damage zone, will also be generated in the specimen's interior. Consequently, there are a large number of strands, essentially made of binder material, which separate the voids that form inside the failure process zone (Fig. 3). Under this condition, the transverse constant is minimized. As the applied strain increases with time, material fracture occurs at the blunted end of the crack tip. This will always be the location of the maximum local strain. The failure of the material between the void and the crack tip causes the crack to grow into the failure process zone. This kind of crack growth mechanism continues until the main crack tip reaches the front of the failure process zone. When this occurs, the crack tip resharpenes temporarily.

Add a space between the word "Fig." and the Figure number throughout.

As mentioned earlier, the development of damage at the crack tip will redistribute the stress in the immediate neighborhood of the damaged area, resulting in an increase in stress in the material outside the damage zone. Consequently, the material outside the damage zone will also accumulate damage. The damage intensity in the newly developed damage zone depends on the magnitude of the applied load, which is a function of time. When the material inside the old failure process zone fails, a new failure process zone has formed at the tip of the resharpener crack. Experimental evidence reveals that the time required for the formation of the failure process zone decreases as the applied load is increased. These local damage and fracture processes are time-dependent and are the main factor responsible for the time-dependent discontinuous crack growth in the material.

Experimental observation reveals that the common crack growth mechanism is void formation in a highly damage<sup>x</sup> zone ahead of the crack tip, and then extension due to ligament rupture. Examination of the specimen fracture surfaces showed that the crack fronts were ideally straight, but with local irregularities. A similar phenomenon was observed by Smith (7). It is well known that for thick specimens made of metallic materials, the crack front will bow in the direction of the crack growth, creating a thumbnail shape. This suggests that there is a plane strain constraint in the center portion of the specimen, which diminishes near the side boundary. However, this may not be true for highly filled polymeric materials. Experimental data obtained from crack propagation tests on highly filled polymeric material specimen<sup>s</sup> revealed that the crack front exhibited no "thumbnailing" both before and after growth. In other words, the crack front was ideally straight, but with local irregularities. The straight crack front observed in solid propellants is believed to be due to the development of a highly damaged zone at the crack tip. The development of the highly damaged zone together with the straight crack front suggest that, within the highly damaged zone, the transverse constraint is very small and that a plane strain fracture toughness may not exist for these materials, as shown in Fig<sup>4</sup>. Figure 4 indicates that the critical Mode I stress intensity for the onset of crack growth is insensitive to the specimen thickness. This phenomenon is discussed in the following paragraphs.

In order to obtain a fundamental understanding of the effect of damage at a crack tip on the fracture toughness, and also to determine damage initiation and evolution processes near the crack tip, three-dimensional numerical modeling analyses were conducted, based on a micro-macromechanical approach.

its symmetrical (?) shape

The specimen was 76.2 mm long, 25.4 mm wide, and 38.1 mm thick, and it had an edge crack of 10.2 mm. Because of symmetry condition, a quarter of the specimen was modeled. A uniform vertical displacement was applied to the top plan<sup>e</sup> of the finite element model. The displacement (strain) was applied incrementally to compute progressive damage. The results of the finite element analysis are discussed in the following paragraph.

The initiation and evolution of damage at the crack tip near the center and near the surface of the specimen <sup>were</sup> determined. It is noted that <sup>damage began</sup> ~~damage~~ <sup>was</sup> ~~initiated~~ earlier near the center than near the surface of the specimen. Since the damage state ~~is~~ <sup>was</sup> closely related to the stress state, the difference in the damage initiation processes is due to the differences between the stress states near the center and near the surface of the specimens. It is known that near the center of the

specimen, the stress state is close to the plane strain stress state as a result of relatively high constraint developed near the center of the specimen. However, near the surface of the specimen, the stress state is close to plane stress conditions. As mentioned earlier, under a triaxial loading condition, it is relatively easy to develop microcracks in the binder and/or debonds at <sup>the</sup> particle-binder interface. Therefore, it is expected that damage will initiate earlier near the center of the specimen. When the material is damaged, both the stiffness and the magnitude of the stress in the damaged region will be reduced. Consequently, redistribution of the stresses occurs and the material adjacent to the damaged material will be subjected to a higher stress that, in turn, will induce damage to the material. These stress redistribution and damage evolution processes continue, and eventually all of the material in the immediate neighborhood of the crack is damaged <sup>3</sup>, i.e., the thickness of the damaged material at the crack tip is equal to the thickness of the specimen <sup>5</sup>, as shown in Fig 5. Under this condition, the transverse constraint is minimized. The uniform distribution of the damage along the crack front will result in a uniform distribution of stress. A similar result was obtained by Liu in his study of damage effect on the distribution of Mode I stress intensity factor  $K_I$  along the crack front (8). The results of three-dimensional elastic finite element analysis reveal that if there is no damage at the crack tip, the largest value of  $K_I$  occurs at the center of the specimen while the smallest value of  $K_I$  occurs near the surface of the specimen. However, when the material at the crack tip is damaged, the distribution of  $K_I$  along the crack front is relatively uniform. Since the crack growth behavior is controlled by the local stress at the crack tip, the uniform distribution of stress along the crack front will also result in a relatively straight crack front, as observed experimentally. This indicates that highly filled solid propellants behave differently from metals, and concepts that appeared clear in one instance are only found to contradict physical reality in another.

The determination of the crack growth rate requires an analysis of discrete <sup>a</sup> data relating the instantaneous time,  $t$ , to the corresponding crack length,  $a$ . Due to <sup>the</sup> nonhomogeneous nature of the particulate composite material, the measured data shows a considerable scatter. Therefore, it is anticipated that a smooth and steadily increasing relationship between the crack growth rate and time is difficult to obtain <sup>3</sup>, and the different methods of  $da/dt$  calculation may result in different solutions. From the results of the crack growth rate calculation, the secant method introduces a pronounced fluctuation of  $da/dt$  <sup>5</sup>, as shown in Fig 6. In other words, the crack growth process consists of a slow-fast-slow phenomenon. As mentioned earlier, the damage process is a time-dependent process <sup>3</sup>, and it required some time to develop a failure process zone at the crack tip. Thus, the crack growth process consists of blunt-growth-blunt and slow-fast-slow phenomena, which is highly nonlinear. The fluctuation of  $da/dt$  is consistent with experimental observation. Based on experimental evidence, in general, the crack does not grow in a continuous and smooth manner. During the crack growth process, crack growth rate both accelerates and decelerates. Therefore, the secant method appears to provide the best estimate of both the actual crack growth process and the actual crack growth rate.

## Conclusions

In this study, local damage mechanisms and strain fields near the crack tip <sup>3</sup>, as well as crack growth behavior in a particulate composite material <sup>5</sup>, were investigated. Experimental results

indicate that, on the macroscale, the material can be considered a continuum, and plane strain fracture toughness may not exist for this material. In the highly strained region at the crack tip, material may be damaged and voids may develop and the crack <sup>can grow</sup> ~~grows~~ by the coalescence of the voids with the crack tip. The crack-damage interaction is a contributing factor to the fluctuation of the crack growth behavior. Experimental results also indicate that crack tip blunting occurs during the loading process, and the crack growth consists of a blunt-growth-blunt phenomenon, which appears to be highly nonlinear. - can grow

## References

1. Beckwith, S.W. and Wang, D.T., "Crack Propagation in Double-Base Propellants," AIAA Paper 78-170, 1978.
2. Liu, C.T., "Crack Growth Behavior in a Composite Propellant with Strain Gradients - Part II, Journal of Spacecraft and Rockets," Vol. 27, (1990), pp. 647-659.
3. Liu, C.T. "Crack Propagation in a Composite Solid Propellant," Proceedings of the Society of Experimental Mechanics, Spring Conference, (1990), pp. 614-620.
4. Liu, C.T. and Smith, C.W., "Temperature and Rate Effects on Stable Crack Growth in a Particulate Composite Material," Experimental Mechanics, Vol. 36, No. 3 (1996), pp. 290-295.
5. Schapery, R.A., On a Theory of Crack Growth in Viscoelastic Media, Report MM 2765-73-1, Texas A&M University, March 1973. italics
6. Knauss, W.G., "Delayed Failure - The Griffith Problem for Linearly Viscoelastic Materials," International Journal of Fracture Mechanics, Vol. 6, pp.7-20 March 1970.
7. Smith, C. W. and Liu, C.T., "Effects of Near-Tip Behavior of Particulate Composites on Classical Concepts," J. of Composites Engineering, Vol.1, No. 4, pp. 249-256, 1991.
8. Liu, C. T., "Three-Dimensional Finite Element Analysis of a Damaged Fracture Specimen," Paper No. AIAA 90-2088, AIAA/SAE/ASME/ASEE 26<sup>th</sup> Joint Propulsion Conf. July 16-18 1990.

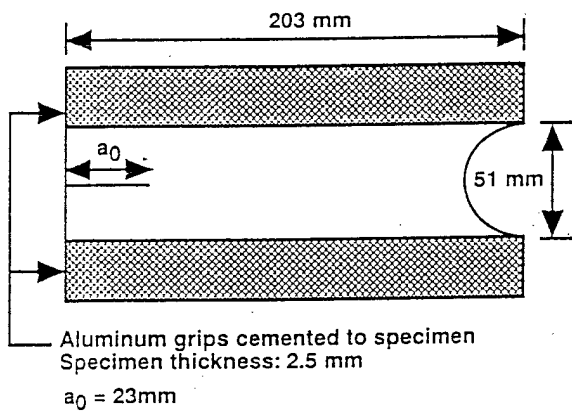

Figure 1 Specimen geometry.

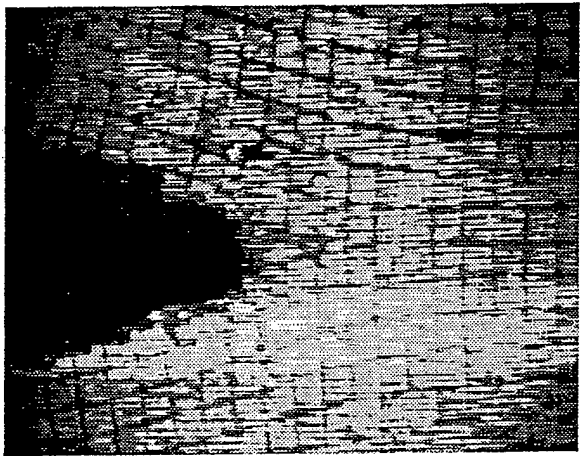
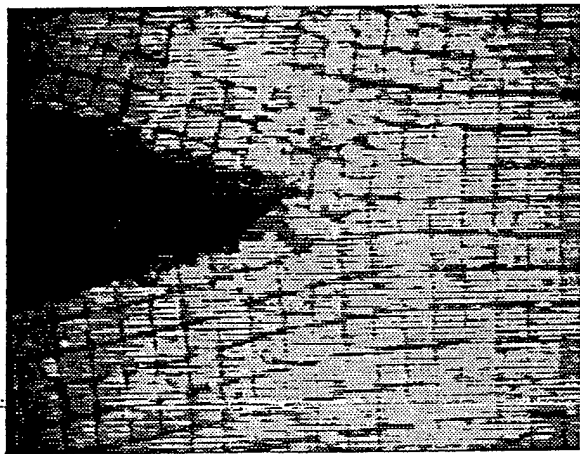
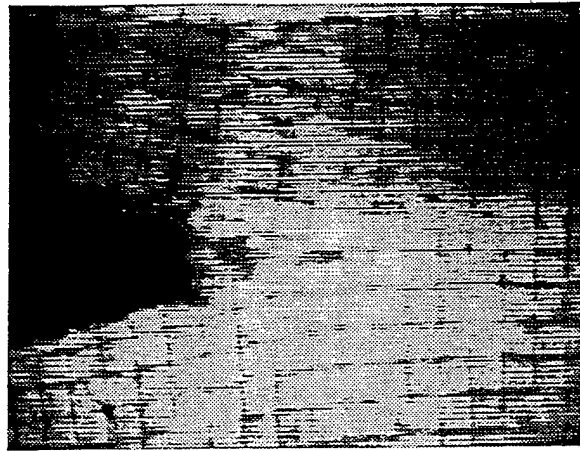

Figure 2 Crack tip profiles.

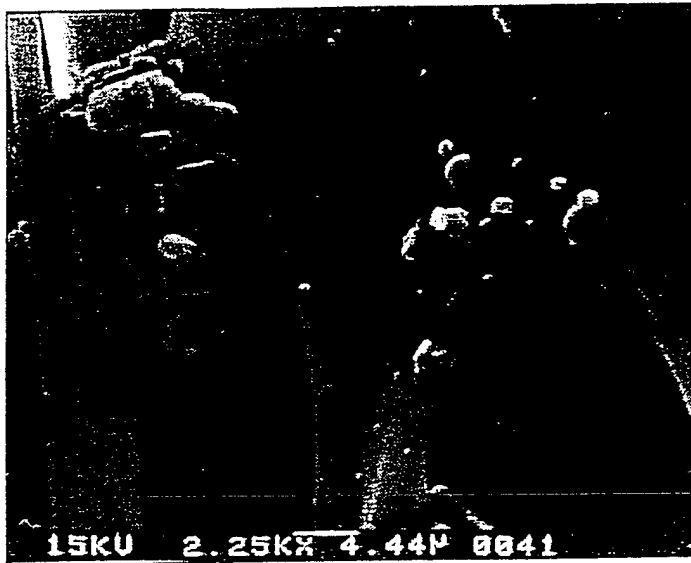

Figure 3 Failure process zone at crack tip.

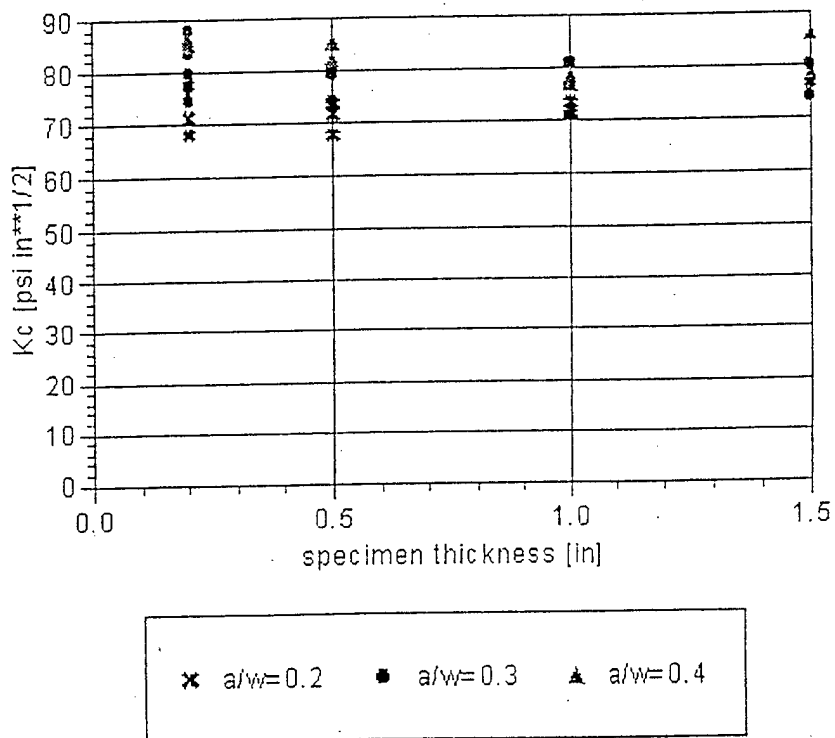

Figure 4 Critical stress intensity factor versus specimen thickness.

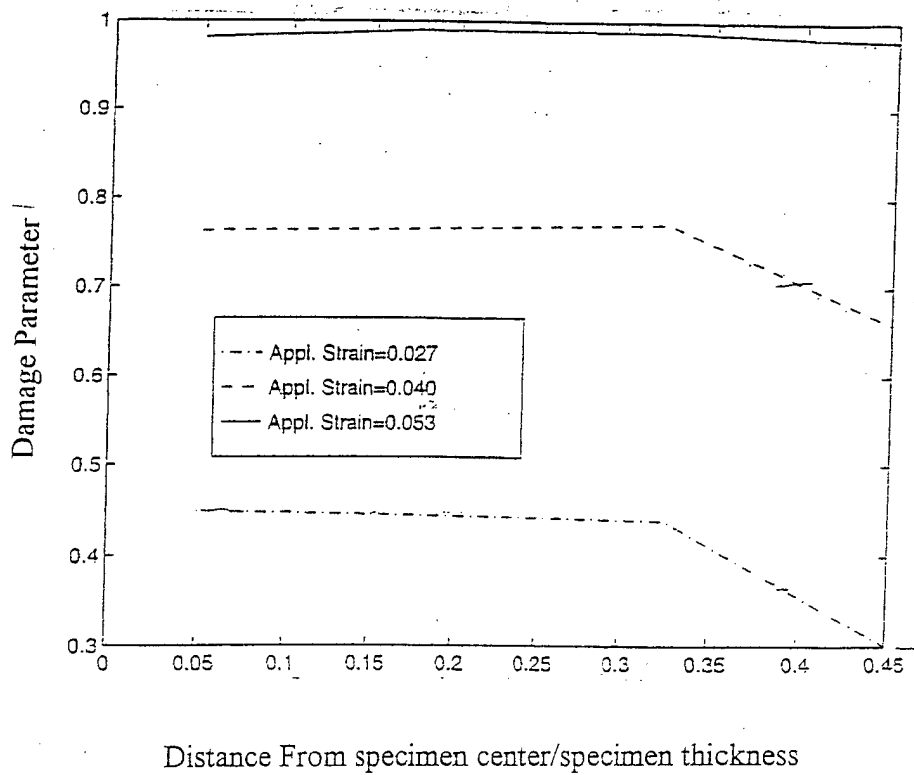

Figure 5 Damage variation along the thickness of the specimen as a function of the applied strain.

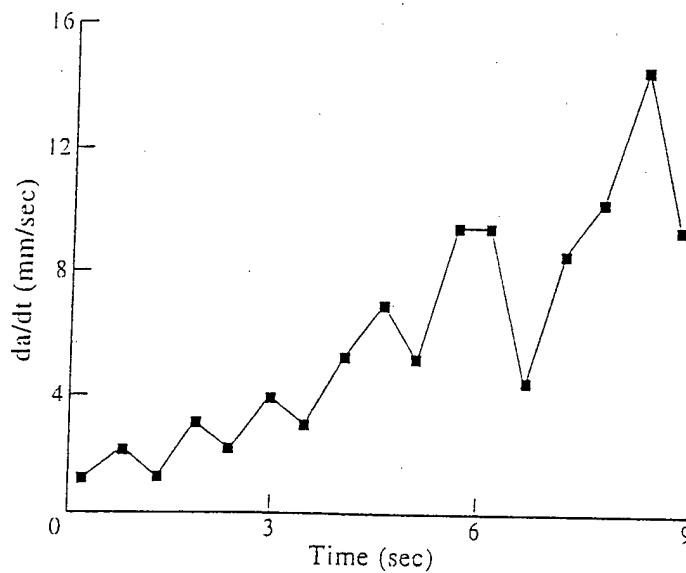

Figure 6 Crack growth rate versus time.