

AD _____

Award Number: DAMD17-99-1-9146

TITLE: Tamoxifen Resistant Breast Cancers: Inappropriate
Transcriptional Coregulators

PRINCIPAL INVESTIGATOR: Kathryn B. Horwitz, Ph.D.

CONTRACTING ORGANIZATION: University of Colorado Health Sciences Center
Denver, Colorado 80262

REPORT DATE: September 2002

TYPE OF REPORT: Final

PREPARED FOR: U.S. Army Medical Research and Materiel Command
Fort Detrick, Maryland 21702-5012

DISTRIBUTION STATEMENT: Approved for Public Release;
Distribution Unlimited

The views, opinions and/or findings contained in this report are those of the author(s) and should not be construed as an official Department of the Army position, policy or decision unless so designated by other documentation.

20030214 217

REPORT DOCUMENTATION PAGE

Form Approved
OMB No. 074-0188

Public reporting burden for this collection of information is estimated to average 1 hour per response, including the time for reviewing instructions, searching existing data sources, gathering and maintaining the data needed, and completing and reviewing this collection of information. Send comments regarding this burden estimate or any other aspect of this collection of information, including suggestions for reducing this burden to Washington Headquarters Services, Directorate for Information Operations and Reports, 1215 Jefferson Davis Highway, Suite 1204, Arlington, VA 22202-4302, and to the Office of Management and Budget, Paperwork Reduction Project (0704-0188), Washington, DC 20503

1. AGENCY USE ONLY (Leave blank)		2. REPORT DATE September 2002	3. REPORT TYPE AND DATES COVERED Final (16 Aug 99 - 15 Aug 02)	
4. TITLE AND SUBTITLE Tamoxifen Resistant Breast Cancers: Inappropriate Transcriptional Coregulators			5. FUNDING NUMBERS DAMD17-99-1-9146	
6. AUTHOR(S) Kathryn B. Horwitz, Ph.D.				
7. PERFORMING ORGANIZATION NAME(S) AND ADDRESS(ES) University of Colorado Health Sciences Center Denver, Colorado 80262 E-Mail: kate.horwitz@uchsc.edu			8. PERFORMING ORGANIZATION REPORT NUMBER	
9. SPONSORING / MONITORING AGENCY NAME(S) AND ADDRESS(ES) U.S. Army Medical Research and Materiel Command Fort Detrick, Maryland 21702-5012			10. SPONSORING / MONITORING AGENCY REPORT NUMBER	
11. SUPPLEMENTARY NOTES report contains color				
12a. DISTRIBUTION / AVAILABILITY STATEMENT Approved for Public Release; Distribution Unlimited			12b. DISTRIBUTION CODE	
13. Abstract (Maximum 200 Words) (abstract should contain no proprietary or confidential information) We speculated that in breast cancers, hormone resistance to antagonists involves the inappropriate recruitment of coregulatory proteins to the transcriptional machinery, which switches antagonists into agonists. We set out to discover transcriptional "coregulators" that influence this switch. We describe here the discovery of an entirely new protein. It has the unusual structural property of having three TPR domains involved in protein-protein interactions, plus four NR boxes, through which nuclear receptors interact with coregulators. We have dubbed this protein NRAP (Nuclear Receptor Accessory Protein). We have isolated and characterized the NRAP gene. We describe the full amino acid sequence of NARP. We have defined the tissue distribution of the transcript. We have raised antibodies to the protein, defined the protein's distribution and show high expression levels in ovarian and breast cancers. We have analyzed the biochemistry of the protein. It interacts simultaneously with heat shock protein 90 and with progesterone (PR) and other nuclear receptors. We have mapped the interaction site for PRs to one NR box. The trimeric NRAP/PR/hsp90 complex is stabilized by antagonist ligands and destabilized by agonists. We speculate that NRAP has scaffolding functions, and that it may be involved in regulating receptor levels by having a role in receptor destruction induced by some antagonists.				
14. SUBJECT TERMS progesterone receptor, estrogen receptor, tamoxifen, RU486, breast cancer, hsp90, corepressor, chaperonin, yeast chock proteins, PR, ER, endocrinology, hormone resistance, yeast two-hybrid, agonist, antagonist, coactivator			15. NUMBER OF PAGES 38	
			16. PRICE CODE	
17. SECURITY CLASSIFICATION OF REPORT Unclassified	18. SECURITY CLASSIFICATION OF THIS PAGE Unclassified	19. SECURITY CLASSIFICATION OF ABSTRACT Unclassified	20. LIMITATION OF ABSTRACT Unlimited	

Table of Contents

Cover.....	1
SF298.....	2
Table of contents.....	3
Body.....	4
Key Research Accomplishments.....	21-22
Reportable Outcomes.....	22
Conclusions.....	24
Appendices	
Figures.....	1-13

Body

Introduction. Patients whose breast cancers are estrogen (ER) and progesterone (PR) receptor-positive respond well to hormone antagonist therapies. However, development of resistance is common, and is a major obstacle to long-term treatment success. Estrogen antagonists like tamoxifen, or progesterone antagonists like RU 486, are "mixed antagonists" having both agonist and antagonist properties. We have shown that the balance between agonist vs. antagonist transcriptional activities can be influenced by the abundance of coregulatory proteins: the corepressors N-CoR and SMRT suppress the partial agonist activities of tamoxifen and RU486, while the coactivator L7/SPA enhances their partial agonist activity. Because of this dual property we proposed that resistance to antagonists is due to a shift in their activity towards the agonist state.

Purpose. The three coregulators above, are unlikely to be the sole players in transcriptional regulation by ER and PR under the influence of antagonists. We speculated that the full complement of coregulatory proteins that could influence the direction of transcription by antagonist-occupied steroid receptors, had yet to be completely identified. L7/SPA is the only antagonist-specific coactivator defined to date. It is unlikely to be the only, or even the most important, protein to have this property. Similarly, it is unlikely that SMRT and N-CoR are the only corepressors that interact with antagonist-occupied steroid receptors. We believe that these three represent a minor subset of the whole, for two reasons. First, screening for coregulators has not focused on receptor N-termini, yet AF1 may be critical to the agonist effects of mixed antagonists. Newer experimental strategies may correct this deficiency. Second, recent crystallographic analyses show subtle structural variations in the conformation of the C-terminal ligand binding domain, dictated by the identity of the ligand. For the most part, protein interaction screens for C-terminal binding proteins have not used antagonists. We proposed to use an antagonist-biased screen to identify antagonist-specific coregulators.

Description. In preliminary studies, we identified three partial cDNA clones encoding proteins that specifically interacted with antagonist-bound PRs. We proposed to clone the complete cDNAs and define their structure (Aim 1); to define the role of the unknown proteins on receptor activity (Aim 2); and, *if they look promising*, to determine the role of these proteins in hormone dependency of breast cancers (Aim 3). In the present studies, we focused on one novel cDNA fragment, initially designated ORF#93, whose features highlighted it as particularly interesting and relevant to our hypothesis. Therefore, the research effort was focused on completely cloning and characterizing this gene and its protein product. The results obtained continue to suggest that this protein may play an important role in nuclear receptor function, and so a series of approaches were undertaken to define the role of the ORF#93 protein that were not anticipated in the original proposal. Since this is an entirely new protein, we have the privilege of naming it. We are leaning towards "NRAP" for "Nuclear Receptor Accessory Protein" but will decide as 2 papers, that are in preparation, near their final stage. Herein we will refer to this protein as NRAP.

Summary. Transcriptional regulation by progesterone receptors (PRs) is a tightly controlled ligand-dependent process that requires receptor association with other cellular proteins. Nascent cytoplasmic PRs require the sequential binding of a large family of heat shock proteins, immunophilins and other chaperones for normal folding and stabilization of the receptors in the cytoplasm. Chaperones also play a role in trafficking PR through the cytoplasm to the cell nucleus, and are essential for transcriptional activity of the receptors. Lastly, transcriptionally active PRs are subject to "ligand dependent down regulation" a stage during which receptors are rapidly lost after transcription has started. Paradoxically, receptor downregulation is often associated with strong transcriptional activity.

We now describe isolation and characterization of a novel protein that interacts with both PRs and with heat shock protein (hsp) 90. It was discovered using antagonist-occupied PRs as bait. The protein is tentatively called NRAP for "nuclear receptor associated protein". We have isolated and characterized the NRAP gene locus which maps to chromosome 15q26.1. We have demonstrated a 3.3kb transcript that encodes a 933 amino acid protein. The transcript is highly expressed in lung, kidney, ovary and testis. We have generated antibodies to the protein. These reagents demonstrate the presence of endogenous NRAP in human ovarian and breast cancer cells.

NRAP contains three tetratricopeptide repeat (TPR) domains involved in protein-protein interactions, and four LXXLL motifs (NR boxes) that are always found in nuclear receptor binding proteins. The presence of these two different protein motifs on a single protein make NRAP entirely unique in structure.

NRAP binds hsp 90 through the TPR domains and PR through at least one NR box , (mapped to NR3 by mutagenesis) simultaneously. Neither site interferes with binding at the other. This suggests that NRAP is involved in assembly of multiprotein complexes. NRAP has a cytoplasmic localization, and does not prevent nuclear translocation of PRs. It has a weak transcriptional enhancing effect on the receptors. We postulate that NRAP plays an early role in the maturation and cytoskeletal trafficking of PRs and that it may have scaffolding functions.

We have entered into a collaboration with D. Toft (Mayo Clinic) to further analyze the chaperonin properties of NRAP and two papers are in preparation. Studies analyzing the role of NRAP in ligand-dependent downregulation are ongoing. The data have been presented at national and international meetings.

Introduction. Progesterone is an essential regulator of normal female reproductive function. It affects cell growth and differentiation in a variety of target tissues (1) by transcriptional regulation of a complex set of target genes (2). Specifically, the hormone is vital for normal growth and differentiation of the breast, but paradoxically, exposure to progesterone and synthetic progestins increases the risk of developing breast cancer. Progesterone effects are mediated by nuclear receptors (PRs) that are expressed as two forms called PR-A and PR-B (3) that have dramatically different functions. All progesterone target tissues including breast cancers, express both receptors. In the normal breast, PR-A and PR-B are equimolar. In cancers this balance is dysregulated and most tumors have an excess of one or the other receptor.

The normal molecular functions of PRs are inseparably linked to their association with other protein partners. Nascent unliganded PRs are associated with a multi-functional protein complex, which includes the heat shock proteins hsp70 and hsp90 and immunophilins. This heterocomplex is responsible for correct assembly and folding of the newly synthesized PRs, and for preventing receptor degradation (reviewed in 4). In particular, hsp90 interacts directly with the hormone binding domain of PRs to facilitate their folding into a high-affinity ligand-binding conformation. This assembly of PRs into their hormone-responsive form is an essential first step in transcriptional regulation by PRs.

Partial dissociation of PRs from this heterocomplex occurs at the time of hormone binding and is coupled with transcription by the receptors. At this point, progestin binding to PRs causes a conformational change and dimerization. This results in association of the liganded PR dimer with specific coactivators and general transcription factors, and with PR binding to DNA at progestin response elements (PREs) in the promoters of target genes (5-9). After transcription is initiated by ligand, the receptors "downregulate" rapidly; protein levels decrease more than 95% in six hours. Paradoxically downregulation is required for strong transcriptional activity. The mechanisms involved in this last stage are unknown.

In sum, the complexity of gene regulation by PRs is controlled in part by receptor interactions with multiple protein partners having chaperone, trafficking, scaffolding, enzymatic, degradative and transcriptional functions (9) and many of these regulators of PR transcriptional activity remain to be identified.

We report here the detailed cloning, structural characterization, and functional analysis of a novel PR interacting protein that also contacts chaperone heterocomplexes. Formation of the trimer between NRAP/PR and hsp90 is promoted by the antiprogestin RU486 and weakened by the progestin agonist R5020. The protein has tentatively been named NRAP, for nuclear receptor associated protein. We are testing the hypothesis that NRAP either 1) facilitates nascent receptor activation, or 2) is involved in ligand-dependent downregulation.

Materials and Methods. Yeast Two-Hybrid Screen. The yeast two-hybrid screen was described previously (10). The plasmid pLEXA:H-HBD was transformed into the *Saccharomyces cerevisiae* reporter strain L40 (Mata his3 Δ 200 trp1-901 leu2-3 112ade2 LYS2::*(lexAop)*₄-HIS3 URA3::*(lexAop)*₈-lacZ GAL4 gal80) to yield the L40-LEXA:H-HBD strain. This strain was transformed with a library of HeLa cell cDNAs fused to the GAL4 activation domain in the pGADGH vector (Clontech, Palo Alto, CA) and plated on selective media containing 10 μ M RU486. Interacting clones were detected by growth on histidine drop-out plates and confirmed by β -galactosidase assay.

GST Pull-down. The pGAD93 cDNA was sub-cloned into pGEX-4T-1 (Promega) and expressed in BL-21 codon+ *E. coli* (Stratagene, La Jolla, CA) as a C-terminal fusion to glutathione S-transferase. Crude bacterial extracts were prepared by sonication in PBS containing 1% triton X-100, 2.5mM DTT, 10% glycerol, 0.5mM PMSF, and Complete protease inhibitors (Roche) at 4 $^{\circ}$ C, followed by centrifugation 10,000 rpm, 10 minutes at 4 $^{\circ}$ C. Supernatants containing gst-93 or gst alone were bound to glutathione sepharose 4B (Amersham-Pharmacia Biotech) at 4 $^{\circ}$ C, for 1 hour. The sepharose slurry was washed three times with binding buffer (20mM HEPES, pH 7.9, 60mM NaCl, 0.1mM EDTA, 6mM MgCl₂, 1mM DTT, 0.5mM PMSF, 10% glycerol, Complete protease inhibitor), then incubated with HeLa whole cell extracts containing transfected PR-A, PR-B or GR, 2 hours at 4 $^{\circ}$ C. Where indicated, samples were incubated in the presence of 10nM R5020, 100nM RU486, 10nM dexamethasone or ethanol vehicle. In this instance, the PR or GR transfected HeLa cells had also been exposed to the same treatment for 1hour prior to harvesting and preparation of whole cell protein extracts. Samples were washed twice with binding buffer containing 0.05% NP-40, and twice with binding buffer alone. The sepharose pellets were resuspended in SDS-PAGE loading buffer and heated to 100 $^{\circ}$ C for 3-5 minutes. Bound proteins were separated on denaturing 7.5% polyacrylamide gels and visualized by immunoblotting, using antibodies to PR and GR.

mRNA detection. Total RNA was isolated from cells by solubilizing samples in a 4M guanidinium isothiocyanate solution and centrifuging through a 5.7M cesium chloride cushion at 100,000 x g. The RNA pellet was further purified by chloroform extraction and two rounds of ethanol precipitation. Total RNA (30 μ g) from HeLa cervical cancer and T47Dco breast cancer cell lines, and an RNA size standard were run on a denaturing 1% agarose gel, and transferred to Hybond N+ membrane (Amersham-Pharmacia Biotech). The pGAD93 transcript was visualized by hybridization to a ³²P-labeled 1kb C-terminal fragment of the pGAD93 cDNA, and exposure to film. A multiple human tissue RNA blot (Clontech) was also screened for pGAD93 transcript expression, following the manufacturer's instructions.

Antibody preparation and protein blotting. A polyclonal antibody was produced using a peptide sequence predicted to be antigenic from the total protein sequence. The antibody detects recombinant, denatured NRAP on immunoblots. The protein has an apparent molecular weight of 103 kDa. However, the polyclonal antibody does not recognize the folded native protein and fails to detect the endogenous protein in HeLa or T47D cells even under denaturing conditions, suggesting that ORF#93 is present in limiting quantities in these cells. Our collaborator, David Toft therefore produced a monoclonal antibody (pGAD93#2) that does detect the endogenous protein in a variety of rodent and human cells and tissues.

Cytosols from tissues and cells were made using the following buffer: 10mM Tris, 50mM KCl, 10mM monothio glycerol, 5mM EDTA, Protease inhibitors (Roche). To detect the protein in the cytosol, 30 µg of cytosolic proteins were loaded on the gel. Immunoprecipitations (IP) were carried out using 800 µg proteins from rat brain and cell lines cytosols and 5µl monoclonal antibody pGAD93#2 ascites coupled to 12.5µl protein G resin. Mixtures were incubated for 30 min at 30C. Resins were washed 4 x 1 ml of above indicated buffer without protease inhibitors supplemented with 0.01% NP40 and bound proteins were eluted with sample buffer, resolved on denaturing 10% polyacrylamide gel, transferred onto PVDF membrane and detected with pGAD93#2 at 1/5000 dilution. PRs were detected with AB-52 as previously described.

Site Directed Mutagenesis. Site directed NRAP mutants were prepared using Chameleon mutagenesis reagents (Stratagene) following the manufacturer's protocol. NRm3 and NRm4 were prepared by mutating the lysine to an alanine in position four of LXXLL motifs 3 and 4, respectively, in the C-terminal yeast 2-hybrid construct of pGAD93.

Cell culture and transcription assays. The T47Dco and T47D-Y, -YA and -YB breast cancer cell lines were generated in our laboratory and have been described previously (11, 12). HeLa cervical carcinoma cells were obtained from the ATCC, Manassas, VA. Cells were maintained as continuous monolayer cultures in modified Eagle's medium (MEM) supplemented with 6ng/ml insulin (Invitrogen-Gibco BRL) and 5% fetal bovine serum (FBS, Hyclone Laboratories, Logan, UT), at 37C and 5% CO₂.

For *transcription assays*, HeLa cells were plated at 2×10^5 cells/10cm dish or 1.2×10^5 /6cm dish, in phenol red-free MEM containing 5% charcoal-stripped FBS one day prior to transfection. Transient transfections were carried out using a standard calcium phosphate precipitate-mediated method. Cells were exposed to precipitates, containing a total of 20µg cDNA per dish, for 16 to 20h. cDNAs encoding PR-A (hPR2) and PR-B (hPR1) have been described. To express NRAP, the cDNA encoding the protein was cloned into the pSG5 expression vector and verified by sequencing. Precipitates were then removed, monolayers were washed with serum-free medium and hormones were added to the cells for 24h, in fresh medium containing 7.5% charcoal-stripped FBS. The cells were harvested, lysed in a detergent buffer, then β-galactosidase and luciferase activities were measured.

For immunohistochemistries, T47D-YB cells were plated onto coverslips in culture dishes at 4×10^5 cells per 6cm dish. The cells were transfected with the pEGFP-C1-93 construct, containing the pGAD93 cDNA fused C-terminally to green fluorescent protein. Two days after transfection, the cells were washed with PBS, and fixed in ice cold 70% acetone-30% methanol. Non-specific binding was blocked using 10% normal goat serum in PBS, 1 hour at room temperature. Cell nuclei were stained using DAPI reagent at 1:10,000 in methanol, 20 minutes at room temperature. After washing PR-B was visualized by incubation with the AB-52 monoclonal antibody to PR, at 1:50 dilution, 2 hours at room temperature, followed by rhodamine-conjugated anti-mouse secondary (1:500, 1 hour, room temperature).

Mammalian 2-hybrid assay. Interactions between pGAD93, hsp-90 and PR A and B were measured in the Mammalian Matchmaker 2-hybrid system (Clontech, Palo Alto, CA). In this system hsp-90 and PR A and B were sub-cloned into the pM vector and expressed as fusions with the DNA binding domain of Gal-4. pGAD93 and PR A and B

were sub-cloned into pVP16AD and expressed as VP16 activation domain fusion proteins. Combinations of the pM and pVP16AD fusion constructs were co-transfected into HeLa cells with a Gal4-tk-luciferase reporter construct containing two Gal-4 response elements upstream of the thymidine kinase promoter and luciferase gene, and interactions were quantitated by measurement of luciferase activity.

Results

Isolation of a peptide fragment (pGAD93) that binds NR HBDs. A construct containing the hinge and hormone binding domain of PR liganded by the antiprogestin RU486, was used as bait in a yeast 2-hybrid screen (10). A number of antagonist-specific PR-interacting proteins were discovered, including a novel 1kb clone with a STOP codon and polyA tail that encoded a 393 amino acid protein fragment, designated pGAD93. In additional screens, pGAD93 interacted with the PR bait only when RU486 was present, suggesting involvement in antagonist-specific effects. Confirmation of the interaction is shown in **Figure 1**. The pGAD93 C-terminal fragment interacted specifically with the PR hinge-HBD bait. In the yeast 2-hybrid verification shown in **Figure 1A**, transformed yeast were grown on selective media containing either RU486 or ethanol. Cotransformation of the cells with the PR hinge-HBD bait and the pGAD93 C-terminus relieved growth suppression in the presence of RU486, but not with vehicle (Fig 1A, segment 1). No growth was observed when cells were transformed with either pGAD93 or the PR bait alone (Fig. 1A, segments 4 and 5, respectively) or when the pGAD93 clone was cotransformed into cells with a lamin-bait vector control (Fig. 1A, segment 2). Cells transformed with the commercially supplied positive control (Fig. 1A, segment 6) or with a ligand-independent constitutively active library clone (Fig. 1A, segment 3) grew on the selective media in both the presence and absence of RU486.

To confirm the interaction between pGAD93 and PR or other steroid hormone receptors, the pGAD93 peptide was expressed as a fusion protein with glutathione S-transferase (gst-93) and used in gst pull-down experiments with whole cell extracts containing over-expressed PR-A, PR-B or glucocorticoid receptors (GR). Products were separated on denaturing polyacrylamide protein gels and immunoblotted for PR or GR. The gst-93 fusion interacts constitutively with both PR-A and PR-B, as well as with GR (**Figure 1B**). A decrease in binding was seen when receptor agonist was present but strong binding was observed in the presence of the mixed antagonist RU486. No binding was observed between the receptors and gst alone. Thus the pGAD93 peptide binds to PR and GR (and ER, not shown) making it a general nuclear receptor (NR) binding protein.

The full-length protein has been tentatively named NRAP for "Nuclear Receptor Associated Protein". NRAP apparently binds NRs well in the absence of hormone or the presence of antagonists, but agonists weaken the binding.

Isolation of the NRAP gene and structure of the full-length protein. The full length NRAP gene was then cloned by a second cDNA library screening and by 5'-RACE. Additionally, a search of the DNA database using the pGAD93 genomic sequence yielded a disorganized BAC clone of chromosome 15. This clone allowed us to identify upstream sequences in the gene, presumably in promoter regions 5' of the transcription start-site. The genomic structure is shown in **Figure 2**. The gene is found at 15q26.1 and is assembled from at least 19 exons, separated by 18 introns of variable size. The region designated as exon 9 in Figure 2 is uncertain and could include more than one intron/exon pair. An interesting splice variant is found in testis, in which the intron between exons 7 and 8 is retained in the transcript, and presumably in the protein product.

The NRAP gene gives rise to an approximately 3.3 kilobase transcript (see Figure 5), encoding a 944 amino acid protein with a predicted electrophoretic mobility of 103 kD. The amino acid sequence of the full-length protein is shown in **Figure 3**. The protein contains three tetratricopeptide repeat (TPR) domains at the N-terminus. Such motifs

are involved in protein-protein interactions in a diverse range of molecules (13). Additionally NRAP contains four LXXLL motifs, or "NR-boxes" designated NR1 – NR4. NR boxes are hallmarks of transcriptional coregulators and it is through these motifs that coregulators bind to nuclear receptors (NRs). Presence of 4 such motifs in NRAP explains its GR and PR, and probably general NR binding properties.

Mapping the NR box/PR interaction. Only the NR3 and NR4 would have been present in the pGAD93 peptide encoded by the initial 1kb clone isolated from the first yeast 2-hybrid assay. To determine whether one or both of these is involved in the interaction between NRAP and PR, mutant constructs were tested in a yeast two-hybrid assay. The constructs consisted of the initial 1kb C-terminal clone, with a single leucine to alanine mutation at position four of LXXLL motif 3 (NR3m) or 4 (NR4m) as indicated in **Figure 4**. Two assays were used: 1) an assessment of the ability of wild-type and mutant NRAP constructs to relieve growth suppression when cotransformed with the PR bait into L40 yeast cells and plated onto selective media containing RU486; and 2) a blue colorimetric assay that measures positive β -galactosidase activity from a cotransformed Gal4 reporter when the PR bait and pGAD93 fragment interact. As expected, the wild-type NRAP C-terminus relieved growth suppression in the presence but not the absence of RU486 (**Table 1**). The colorimetric assay confirmed these results. The NR3m mutant was unable to rescue growth while the NR4m behaved like wild-type NRAP. We conclude that an intact NR3 is required for NRAP interaction with PR.

NRAP transcript expression. The NRAP transcript is ubiquitously expressed, with highest levels found in the kidney and lung (**Figure 5**). The transcript is also detected in progestin target tissues including the ovary and mammary gland. Interestingly, the lowest levels are found in brain regions. Probing a northern blot of total RNA from HeLa cervical carcinoma cells and T47Dco breast cancer cells revealed a single RNA species, with a mobility close to the predicted 3.3kb (**Figure 5, inset**).

NRAP protein expression; a multiprotein complex with PR and hsp90. We generated a polyclonal antibody to NRAP that identifies the full-length exogenously expressed protein (not shown). David Toft's lab generated a monoclonal antibody to NRAP. It was used to detect the endogenous protein by immunoblotting in cytosols of rodent and human tissues (**Figure 6A**). Among the tissues examined, highest expression levels of NRAP were seen in mouse lung, kidney, liver, spleen and uterus. The protein was also present in tongue, brain and testis, and was lowest in heart and muscle cytosols. It is abundant in a human ovarian cancer cell line. The doublet most likely indicates presence of two isoforms or heterogenous phosphorylation states.

NRAP expression was next assessed in human breast cancer cells (**Figure 6B**) in relation to the expression of PRs and hsp90. Both T47D-YA and T47D-YB cells express the protein, and two isoforms may exist. NRAP appears to exist as part of a multiprotein complex that includes PR and hsp90. This experiment was performed in the laboratory of David Toft. Additional studies using purified components of the PR chaperonin complex including purified NRAP are ongoing in the Toft lab.

Subcellular localization of NRAP protein. To determine the cellular localization of NRAP, the protein was expressed as a fusion with green fluorescent protein (gfp-NRAP). The gfp-NRAP construct was transiently transfected into T47D-YB breast cancer cells, which express high levels of PR-B. The cells were either untreated or treated with R5020 or RU486, then fixed, and NRAP was visualized by direct green fluorescence. Nuclei were

stained blue using DAPI. As shown in **Figure 7**, NRAP was cytoplasmic regardless of hormone treatments.

To confirm that PRs were nuclear under these conditions, a second study was done in which NRAP and the receptors were simultaneously visualized; the receptors by immunohistochemically using a rhodamine-conjugated secondary antibody (**Figure 8**). In positively transfected cells green gfp-NRAP had a strong cytoplasmic expression. The majority of PR-B protein was detected in cell nuclei, however, with weak cytoplasmic staining in the untreated cells. Treatment with either R5020 or RU486, resulted in tight nuclear localization of PR-B. Under these conditions, gfp-NRAP remained cytoplasmic. Furthermore, PR-B localization was not affected by over-expression of gfp-NRAP and did not differ between NRAP transfected and untransfected cells. This suggests that the interaction between NRAP and PR is transient, perhaps occurring during the initial receptor translation and folding stages.

NRAP function: transcription. NRAP is not a reliable ligand-dependent transcriptional activator of PR (or GR) although it has weak transcriptional activation properties overall. When transfected into PR negative HeLa cells in increasing concentrations with a constant amount of PR-B and a progestin-responsive luciferase reporter, transcriptional activity is weakly enhanced (**Figure 8**) by the agonist R5020, but not by the antagonist RU486.

NRAP function: hsp90 cochaperone? Full length NRAP contains three TPR domains, usually involved in protein-protein interactions (13). TPR domains have been described in a number of hsp90 interacting proteins (14). Since NRAP is primarily cytoplasmic, we postulated that it is a component of the PR chaperone complex, required in the early stages of PR synthesis, folding and stabilization, or the initial nuclear relocation of the nascent receptors. Therefore, mammalian 2-hybrid assays were used to investigate a possible interaction between NRAP and hsp90, and to determine whether this influences the dynamics of the PR-chaperone complex. In this assay hsp90 was expressed as a fusion with the gal4 DNA binding domain, and NRAP was linked to the activation domain of VP-16. Interaction between the fusion proteins in a transient transfection assay was monitored by activation of a gal4-luciferase reporter (**Figure 10**).

When hsp90, PR-B and NRAP constructs were cotransfected into HeLa cells along with the reporter, a constitutive interaction was consistently observed among the proteins in the absence of hormone (**Figure 10A**). Thus, hsp90 interacts with NRAP; PR-B interact with NRAP; and PR-B interact with hsp90; all in dimeric complexes. In an effort to demonstrate existence of trimeric complexes with higher interactive capacity, the hsp90/NRAP interaction was assessed in the presence of cotransfected PR, and the hsp90/PR interaction was assessed in the presence of cotransfected NRAP. However addition of the third reactant had no significant effect on activity of the reporter. Reporter activity of hsp90 alone, or of NRAP alone, are shown as controls.

We next addressed the role of hormones, if any -- the agonist R5020 (stripped bars); the antagonist RU486 (open bars); or no ligand (grey bars) -- on interactions among any two of the proteins, and results are reported as fold activity above controls (**Figure 10B**) calculated as in Figure 10A. As in Figure 10A, trimeric protein assembly was also assessed by cotransfection of the third protein partner. The results are of considerable interest but require further study: First, the dimeric interaction between hsp90 and NRAP is not influenced by hormone (Group 1) as would be expected in the absence of

receptors. However, addition of PR-B disrupts the hsp90/NRAP dimer only in the presence of RU486 (Group 2). It is possible that hsp90 and NRAP compete for binding to PR-B under these conditions. Second, PR/NRAP dimeric interactions are constitutive and disrupted by R5020 and RU486 (Group 3). Third, PR-B/hsp90 interactions are inhibited by R5020, but enhanced by RU486 as would be expected if dissociation of hsp90 is involved in PR activation by agonist and if antagonist promotes hsp90 association. Interestingly, NRAP increases PR-B/hsp90 affinity, suggesting that it stabilizes the PR-B/hsp90 dimer thereby enhancing the ability of RU486 to block PR-B activation. We speculate that RU486 disrupts the PR/NRAP dimer but stabilizes the PR/NRAP/hsp90 trimer. The stabilizing effect of RU486 on PR-B/hsp90 interactions was not observed with the PR-A isoform, or with the pure antagonist ZK98299 (not shown).

Discussion

Association of nascent PRs with heat shock protein/immunophilin heterocomplexes is essential for proper protein folding and conformational assembly of the receptors. Hsp90 binds directly to the hormone binding domain of PRs and loss of this binding inhibits the transcriptional activity of the receptors. In turn, hsp90 associates with numerous other immunophilins and heat shock proteins that together form the multiprotein chaperone complex responsible for PR folding and stabilization. Immunophilins such as Cyp40 and FKBP52 do not interact directly with PRs but contain TPR domains through which they compete for specific binding to hsp90. The roles played by all the members of the chaperone complex are only partially characterized, but their assembly appears to be sequential, suggesting specific functions for each step.

We now describe a novel TPR-containing protein that binds not only hsp90 directly, but also binds directly to PRs through at least one of 4 NR box motifs. The presence of both TPR domains and NR boxes makes this a very unique protein. What are TPR domains? The function of TPR domains is still poorly understood but they invariably mediate protein-protein interactions in a variety of proteins. The TPR is a degenerate 34 amino acid repeat motif that is evolutionarily widespread. Proteins with TPR motifs are found from bacteria to man and are involved in functions as diverse as cell-cycling; transcriptional activation and repression; multiple enzymatic activities; etc. (15). As shown in **Figure 11** proteins having a variety of functions contain TPR motifs for protein-protein interactions, plus other motifs to perform the desired biochemistry on the associated protein partner. In the case of NRAP, the NR boxes indicate that the desired protein partners are nuclear receptors. No other TPR containing protein has been described having this secondary function.

TPR motifs are a highly versatile class of protein interaction motifs. They have a conserved architecture involving a "TPR fold" that has been defined by X-ray crystallography. Each 34 amino acid block forms a pair of antiparallel α -helices that arrange in a tandem array into a superhelical structure that encloses a central groove. This serves as a socket for the specific, high affinity binding of a protein partner.

The primary amino acids of TPR motifs are loosely conserved. Despite this, functionally related TPR domains from different proteins contain amino acids in key positions outside the limited consensus pattern that are well conserved. For example, key small vs. large, or hydrophobic vs. charged/polar amino acids from several hsp90-binding proteins – human and bovine Cyp40, human PP5, yeast ST11 and rabbit FKBP52 – were compared with the three TPR domains of NRAP (**Figure 12**). As shown, the same key residues that were conserved in the other hsp90-binding proteins were well conserved in NRAP's TPR1 and TPR2, and partially conserved in TPR3. It is therefore highly likely that NRAP binds hsp90 endogenously through one or more of its TPR domains, as we have shown experimentally.

A working model. The C-terminal fragment of NRAP that was first isolated with the PR bait does not contain the 3 N-terminal TPR domains, suggesting: 1) that NRAP does not bind PRs through these domains; and 2) that binding of PR to NRAP is not indirect by coupling through hsp90. Based on this, and the studies described in Figure 10, it is likely that PR/hsp90 and PR/NRAP can exist as separate dimeric complexes, and that formation of the PR/hsp90/NRAP trimer subserves a separate and distinct function. Furthermore, since mutation of an NR box-like LXXLL domain in the NRAP C-terminus abolishes its interaction with PRs (Figure 4), clearly at least one NR box, NR3, mediates

NRAP/PR association. NRAP contains four potential NR boxes. It is possible that the other NR boxes are targets of different nuclear receptors; such specialization has been described for coactivator proteins.

PRs are synthesized in the cytoplasm and localize to the nucleus in a hormone independent fashion. The interactions that take place between the nascent receptors and various chaperone components in the cytoplasm occur in a dynamic and sequential manner and probably play a role in nuclear trafficking. Thus, some chaperones are found associated with PR in the nucleus, while others associate only with the cytoplasmic state of the receptors. The fact that NRAP is localized to the cytoplasm and does not prevent nuclear translocation suggests that it associates with the chaperone heterocomplex early in PR formation.

Our working model is outlined in **Figure 13**. We speculate that formation of the trimeric complex is ligand independent (Figure 10) and occurs in the cytoplasm. Addition of agonist breaks up the complex, a step that may be needed for PR binding to DNA. Whether the entire complex dissociates, or only some of its components including NRAP, is unclear. The destabilized complex may be targeted for ubiquitination and ligand-dependent down-regulation. On the other hand, and antagonist stabilizes the trimeric complex, and this may be one way by which such ligands inhibit transcription.

Collaboration with David Toft

Because of the clear relationship between our new protein, and the PR/hsp90 multiprotein complex, as well as the differential effects of agonist and antagonist ligands on complex formation, we entered into a collaboration with David Toft, PhD (Mayo Clinic, Rochester, MN), a highly regarded expert on chaperonins and PRs. We asked him to determine whether NRAP is involved in the maturation of PR and/or the selective binding of hormones to activated PR. Dr. Toft and a postdoctoral fellow, Ahmed Chaldi, PhD have now demonstrated that NRAP is recruited to PRs in reconstituted complexes formed from purified chaperone components. By PR immunoprecipitation they have demonstrated that NRAP binds in a reconstituted complex that includes PR, hsp90, hsp70, Hop, hsp40 and p23. Interestingly, NRAP interaction with the complex is mediated by PR; namely NRAP is brought to the complex by the PRs. In an attempt to define a function for NRAP a ligand binding assay was performed. Ligand binding requires the NRAP-free multiprotein complex; addition of NRAP inhibits agonist binding by more than 50%. This suggests again that NRAP association with PR occurs at early stages after its synthesis. However even more intriguing is the possibility that NRAP is involved in silencing PR signaling after transcription, during the ligand-dependent downregulation stage. These hypotheses are being studied. Also underway is a study to demonstrate how RU486 binding to PR is influenced by the presence of NRAP.

In sum, during the course of these investigations we discovered and have characterized an entirely new protein that binds PRs and engages the multiprotein chaperonin complex. We have tentatively called this protein NRAP, nuclear receptor associated protein.

Two joint papers authored by members of the Horwitz and Toft labs, are in preparation.

Figure Legends

Figure 1. Characterization of a PR-interacting peptide "pGAD93"

A – The interaction between pGAD93 and the hinge-HBD region of PR was confirmed in the yeast 2-hybrid assay. The L40 yeast strain was transformed with the plasmid constructs: 1) pGAD93 + pBTM116:hHBD-PR, 2) pGAD93 + pBTM116:lamin, 3) pGAD112, 4) pGAD93 alone, 5) pBTM116:hHBD-PR alone, or 6) positive control construct. The transformed cells were plated on synthetic dextrose agar dropout plates (SD-LEU-TRP-HIS) containing 10 μ M RU486 or vehicle, as indicated, and growth was monitored for 3 to 5 days at 30C.

B – Interaction between gst-pGAD93 and PR-A, PR-B and GR: HeLa cell lysates containing transfected PR-A, PR-B or GR, were incubated 1h at 4C with gst-pGAD93-bound sepharose or gst-alone sepharose in the presence of 10nM R5020, 100nM RU486 or 10nM dexamethasone, as indicated. Protein-bound sepharose samples were pelleted and washed. Samples were fractionated on 7.5% SDS-PAGE and PR and GR were visualized by immunoblotting.

Figure 2. Genomic structure of the NRAP locus at 15q21.3

Exons that make up the coding region of the NRAP locus are represented as boxes corresponding to exon number. The size (in bp) of the intervening intronic sequences are below each exon separation. The corresponding basepair numbers of the cDNA coding region of each exon is above. A splice variant found in testis includes the 305 bp intronic sequences between exons 7 and 8 (circled). The size of the two introns between exons 8, 9 and 10 are not known (?) due to a discontinuity in the genomic database at this position in chromosome 15. The STOP codon and polyadenylation signal sequences are labeled in exon 19.

Figure 3. Amino acid sequence and protein structural features of the full-length protein "NRAP"

The sequence of the 944 amino acid full-length protein is shown. Three tandem TPR (tetratricopeptide repeat) domains at the N-terminus are marked in the cartoon and underlined in the sequence. The four NR (nuclear receptor) boxes are in red. NR3 is required for NRAP/PR interaction.

Figure 4. Mutational analysis of the NRAP C-terminal NR3 and NR4 show that NR4 is required for interaction with PR

A schematic of NRAP showing the three TPR domains and four putative NR box motifs are shown. Also indicated as "C-term" is the the start of the originally clone pGAD93 fragment. This fragment contains NR3 and NR4. The sequence substitutions of site-directed NR box mutants, NR3m and NR4m are indicated.

The ability of wild-type C-term fragments or ones containing a single bp L to A substitution in NR3 or NR4, were compared for their ability to interact with PRs using the yeast 2-hybrid assay. Interactions were measured by their ability to rescue cells from growth inhibition, or to induce β -gal transcription as measured by a colorimetric assay.

Figure 5. Size and tissue distribution of the NRAP transcript

A multiple human tissue RNA blot (Clontech) was probed with the 32 P-labeled 1kb C-terminal fragment of the NRAP cDNA, following the manufacturer's instructions. Relative spot intensities representing NRAP transcript levels in each tissue were estimated by densitometry. The transcript is highly expressed in lung and kidney. It is also expressed in several endocrine organs. Its lowest levels are in brain centers.

Inset – NRAP transcripts were visualized by northern blotting in 30 μ g total RNA isolated from HeLa cervical cancer and T47Dco breast cancer cell lines. Transcript size was estimated using a commercial RNA ladder, and the positions of 18S and 28S rRNA subunits are indicated. One major transcript of ~3.3 kb is detected.

Figure 6. Tissue distribution of the NRAP protein detected by immunoblotting and coimmunoprecipitation with PR and hsp90

A – Two types of antibodies to the protein were made: a peptide derived polyclonal serum by the Horwitz lab, and a peptide derived monoclonal (pGAD93#2) antibody by the Toft lab. Using the monoclonal, NRAP protein was detected by immunoblotting of rodent tissues and human cell lines. Cytosols from rodent tissues were: 1. Lung, 2. Heart, 3. Kidney, 4. Liver, 5. Spleen, 6. Muscle, 7. Tongue, 8. Brain, 9. Testis, 10. Uterus, 11. Rat brain cytosol, 12. IP from Rat brain cytosol. Human tissues were: 13. Human Ovarian cancer cell line OVCAR-8 cytosol, and 14. immunoprecipitated protein; 15. Human Ovarian cancer cell line MDAH2774 cytosol, and 16. immunoprecipitated protein; 17. Human Ovarian cancer cell line PA1 cytosol, and 18. immunoprecipitated protein.

B – Expression of NRAP and its in vitro interactions with PR and hsp90 in T47D human breast cancer cells. Cytosol was prepared from T47D-YA and -YB cells which express PR-A or PR-B respectively. Endogenous NRAP, PR-A or PR-B, and hsp90 were immunoprecipitated using respectively, a monoclonal antibody to NRAP (pGAD93#2); antibodies to the PRs (AB-52, PR6); and a monoclonal antibody to hsp90 (H90.10). Nonspecifically bound proteins were removed by washing and specifically bound proteins were eluted from the resin with sample buffer, separated by electrophoresis and transferred to a PVDF membrane. The membrane was probed with pGAD93#2 (panel A) to detect NRAP, then with AB-52 (panel B) to detect the PRs. Hsp 90 was detected as a large band migrating just below NRAP.

Figure 7. NRAP is a cytoplasmic protein

The NRAP cDNA was fused to green fluorescent protein cDNA to yield gfp-NRAP. gfp-NRAP was expressed in T47D-YB cells by transient transfection of the cDNA. Cells were treated for 1 hour without or with R5020 or RU486 and fluorescence was detected microscopically and photographed. Cell nuclei were visualized by DAPI staining.

Figure 8. Codetection of NRAP and PRs: the two proteins segregate to different cellular compartments

gfp-NRAP was transiently expressed in T47D-YB cells and the cells were treated without or with 10nM R5020 or 100nM RU486 for one hour before fixation and DAPI staining. PR were visualized by incubation with the anti-PR monoclonal antibody AB-52 followed by incubation with a rhodamine-conjugated anti-mouse secondary antibody. Cells were visualized by fluorescence microscopy and photographed.

Figure 9. NRAP has minimal effects on transcription by PR

HeLa cells were transfected with 10ng of the PR-B expression vector (hPR1), 1 μ g PRE₂-TATA-Luc and 250ng pCH110, in the presence of increasing quantities of an NRAP cDNA cloned into the pSG5 expression vector. Luciferase and β -galactosidase activities were measured in harvested cell lysates, 16-20h after treatment of the cells with 10nM R5020 or RU486 as shown. Reporter activity is shown corrected for β -galactosidase activity and corrected for the transcription in the absence of ligand.

Figure 10. Interactions among NRAP, hsp90 and PR.

A – Constitutive interactions. Constructs containing encoding NRAP, PR-B and hsp90 linked to the Gal4DNA binding domain and/or VP16 activation domain, were cotransfected into HeLa cells as indicated, and harvested two days later. Where indicated the PR-B and NRAP constitutive expression vectors were included in the transfection. Protein-protein interactions were estimated as luciferase activity arising from a cotransfected Gal4 response element reporter, and are shown corrected for β -galactosidase activity. The Gal4-hsp90 and pVP16-pGAD93 constructs were cotransfected with empty VP16 and Gal4DBD controls, respectively (right two bars). Error bars represent the standard deviations of triplicate determinations.

B – Hormone-dependent interactions. The effects of 10nM R5020 (striped bars), 100nM RU486 (open bars) or vehicle (filled bars) on the dynamics of interactions among PR-B, NRAP and hsp90 were estimated in the mammalian two-hybrid assay. Results are shown relative to the VP16-pGAD93 + empty Gal4DBD vector control, and represent triplicate determinations.

Figure 11. TPR domains are found in a variety of proteins with different functions but only NRAP contains NR boxes

A cartoon showing the structure of six proteins known to contain TPR domains, in comparison to NRAP. The other proteins have enzymatic, chaperonin and other functions as shown by the presence of motifs specifically associated with those functions. None resembles NRAP, which is unique in that it also contains 4 canonical NR boxes through which it binds PR and probably other NRs.

Figure 12. TPR domain residues are conserved among proteins that bind hsp90

The putative TPR domains of NRAP are compared with similar domains from known hsp90 interacting proteins of humans and other species. The degenerate TPR consensus sequence is shown above, and charged/polar (shaded black), small (boxed) and large hydrophobic (shaded gray) residues in key conserved positions are shown. Preservation of these residues strongly suggests that like the other proteins, NRAP is also an hsp90 interacting protein.

Figure 13. A working model of NRAP association with PR and hsp90 and the role of ligand

Model of NRAP interaction with nascent PR. The model envisions that agonist binding leads to PR dimerization which destabilizes binding of the chaperonins. The antagonist RU486 on the other hand stabilizes the affinity of the hsp90/NRAP complex for PR and inhibits activation.

Selected References

1. **Clarke, C. L. and R. L. Sutherland.** 1990. Progesterin regulation of cellular proliferation. *Endocr. Rev.* **11**:266-301.
2. **Graham, J. D. and C. L. Clarke.** 1997. Physiological action of progesterone in target tissues. *Endocr. Rev.* **18**:502-519.
3. **Kastner, P., A. Krust, B. Turcotte, U. Stropp, L. Tora, H. Gronemeyer and P. Chambon.** 1990. Two distinct estrogen-regulated promoters generate transcripts encoding the two functionally different human progesterone receptor forms A and B. *EMBO J.* **9**:1603-1614.
4. **Pratt, W. B. and D. O. Toft.** 1997. Steroid receptor interactions with heat shock protein and immunophilin chaperones. *Endocr Rev* **18**:306-360.
5. **Shibata, H., T. E. Spencer, S. A. Onate, G. Jenster, S. Y. Tsai, M. J. Tsai and O. M. BW.** 1997. Role of co-activators and co-repressors in the mechanism of steroid/thyroid receptor action. *Recent Prog Horm Res* **52**:141-164.
6. **Glass, C. K., D. W. Rose and M. G. Rosenfeld.** 1997. Nuclear receptor coactivators. *Curr. Opinion Cell Biol.* **9**:222-232.
7. **Horwitz, K. B., T. A. Jackson, D. L. Bain, J. K. Richer, G. S. Takimoto and L. Tung.** 1996. Nuclear receptor coactivators and corepressors. *Mol Endocrinol* **10**:1167-1177.
8. **Tsai, M.-J. and B. W. O'Malley.** 1994. Molecular mechanisms of action of steroid/thyroid receptor superfamily members. *Ann. Rev. Biochem.* **63**:451-486.
9. **McKenna, N. J. and B. W. O'Malley.** 2002. Combinatorial control of gene expression by nuclear receptors and coregulators. *Cell* **108**:465-474.
10. **Jackson, T. A., J. K. Richer, D. L. Bain, G. S. Takimoto, L. Tung and K. B. Horwitz.** 1997. The partial agonist activity of antagonist-occupied steroid receptors is controlled by a novel hinge domain-binding coactivator L7/SPA and the corepressors N-CoR or SMRT. *Mol Endocrinol* **11**:693-705.
11. **Horwitz, K. B. and G. R. Freidenberg.** 1985. Growth inhibition and increase of insulin receptors in antiestrogen-resistant T47DCO human breast cancer cells by progestins: implications for endocrine therapies. *Cancer Res* **45**:167-173.
12. **Sartorius, C. A., S. D. Groshong, L. A. Miller, R. L. Powell, L. Tung, G. S. Takimoto and K. B. Horwitz.** 1994. New T47D breast cancer cell lines for the independent study of progesterone B- and A-receptors: only antiprogestin-occupied B-receptors are switched to transcriptional agonists by cAMP. *Cancer Res* **54**:3868-3877.
13. **Blatch, G. L. and M. Lassle.** 1999. The tetratricopeptide repeat: a structural motif mediating protein-protein interactions. *BioEssays* **21**:932-939.
14. **Owens-Grillo, J. K., M. J. Czar, K. A. Hutchison, K. Hoffmann, G. H. Perdew and W. B. Pratt.** 1996. A model of protein targeting mediated by immunophilins and other proteins that bind to hsp90 via tetratricopeptide (TPR) repeat domains. *J. Biol. Chem.* **271**:13468-13475.
15. **Lamb, JR., Tugendreich, S., and Heiter, P.** Tetratricopeptide repeat interactions: to TPR or not to TPR? *Trends in Biological Sciences* **20**:257-259, 1995.

Key Research Accomplishments

- ✓ A cDNA was isolated (pGAD93) that encodes a novel peptide, which interacts with the antagonist occupied PR hormone binding domain.
- ✓ Starting with pGAD93 the full length cDNA clone was isolated and sequenced. The NRAP gene maps to chromosome 15q26.1.
- ✓ The organization of the gene has been determined: it consists of at least 19 exons with intervening introns of various sizes. A novel transcript is found in testis.
- ✓ The cDNA encodes a protein we have named NRAP (Nuclear Receptor Associated Protein) that has unique structural features. At its C-terminus, NRAP contains 3 tandem **tetratricopeptide repeat (TPR) domains**. Such domains are found in proteins involved in protein-protein interactions such as protein chaperones, trafficking and scaffolding proteins and proteins with a variety of enzymatic functions. The TPR domains anchor a protein partner being modified. Additionally, NRAP contains four LXXLL motifs, or **NR boxes**, that are found in proteins which bind to nuclear receptors (NR) like PRs. The combination of TPR domains plus NR box motifs makes NRAP an entirely novel protein.
- ✓ Of the 4 NR boxes, two have been studied for their role in PR binding. Mutation of NR box 3 leads to loss of PR binding. This proves that PR binds directly to NRAP though NR3
- ✓ Binding of NRAP to the hinge-HBD C-terminus of PR through the NR box is RU486 dependent. This has been analyzed by yeast 2-hybrid assays in which the PR bait and NRAP were fused to the VP16 activation domain or the Gal4 DNA binding domain, and interactions were monitored by a transcriptional readout.
- ✓ NRAP also forms heterodimers independently with PR and with hsp90. The TPR domains are involved in hsp90 binding. NRAP binds PR and hsp90 simultaneously and neither side interferes with binding by the other. Thus NRAP behaves like a scaffolding protein by separately bringing together hsp90 and PRs. This trimeric interaction is enhanced by RU486 and weakened by R5020.
- ✓ NRAP binds GR and ER making it a general NR binding protein, perhaps stabilized by antagonists.
- ✓ The open reading frame of the NRAP gene encodes a 2832 bp transcript of approximately 3.3Kb, which translates into a 944 aa protein product with a mass of approximately 104 kDa.
- ✓ The transcript is found in many tissues. It is especially high in the lung, kidney, ovary and testes; it is especially low in the brain.
- ✓ Polyclonal and monoclonal antibodies to NRAP have been generated. The antibodies demonstrate the presence of the protein (perhaps as two isomers or phosphorylation states) in a variety of rodent tissues.
- ✓ High levels of NRAP are found in human ovarian and breast cancer cells.
- ✓ A "green fluorescent protein" (gfp)-NRAP fusion protein has been constructed. Fluorescence microscopy shows that the protein is localized in the cytoplasm irrespective of hormone treatment or localization of PRs.

- ✓ An expression vector encoding the full-length NRAP protein has been generated. This vector has been used in transient transfection assays to probe 1) functional properties; and 2) protein-protein interactions. NRAP appears to have little if any effect on PR mediated transcription.
- ✓ In sum, the TPR domains of NRAP are homologous to those found on other hsp90 binding proteins, but the additional presence of 4 NR boxes makes the protein entirely unique. This protein appears to influence the inhibitory properties of steroid antagonists.

We set out to find new "coregulators" that influence the transcriptional activity of steroid receptor antagonists. What we have discovered instead, is a brand new protein, with entirely novel structural properties, that complexes binding of nuclear receptors to protein chaperones in a manner that is stabilized by antagonist hormones. We speculate that this protein has importance beyond simply tweaking transcriptional levels up or down. Instead, this protein may shed light on fundamental mechanisms by which hormone antagonists influence receptor protein levels and protein stability. This is key to understanding how antagonists actually work in cancer cells. For example, the pure antiestrogen, Fulvestrant, is now replacing tamoxifen for breast cancer treatments. Fulvestrant is preferred to Tamoxifen, because unlike Tamoxifen, binding of Fulvestrant to estrogen receptors leads to receptor degradation analogous to ligand-dependent down regulation. No one knows how this degradation occurs. Clearly transient loss of tumor ER temporarily prevents estrogens from stimulating tumor growth, which is desirable. We strongly suspect that a protein like NRAP is involved in this receptor loss caused by an antagonist like Fulvestrant.

Therefore, as is often the case in science, we set out to find one thing, and ended up finding something different and perhaps more important. While the funds supplied by the DOD for this project are now expended, the work will continue because we believe it is too important to drop.

While we have a lot of information on NRAP, as outlined above, our plan till now has been to hold off on publication of a description of this novel protein until we have a better handle on its function(s). To that end we entered into a collaboration with David Toft to further analyze the scaffolding and chaperonin functions of NRAP. A series of studies have been completed by Dr. Toft that are not reported here. Two comprehensive manuscripts co-authored by members of the two labs are therefore in preparation.

Reportable outcomes

Results generated over this reporting period are being prepared in manuscript form as discussed above, for submission under the tentative titles:

Graham DJ, Abel MG, Gordon DF, Chaldi A, Wood WM, Toft D and Horwitz, KB (2002) NRAP: a novel chaperonin protein with NR boxes that bind progesterone receptors and influence the function of mediates the function of the antiprogestin RU486. (manuscript in preparation).

Chaldi A, Abel GM; Graham JD; Horwitz KB and Toft D. (2002) The scaffolding protein, NRAP, is an early component of the PR chaperonin complex that influences progesterone receptor maturation and acquisition of hormone binding ability. (manuscript in preparation).

The data have however been presented at national and international meetings:

Presented at **Proceedings of the Keystone Symposium: Nuclear Receptors, USA, 2000 and 2002.**

NOVEL INTERACTORS MEDIATING MIXED ANTAGONIST ACTION ON ESTROGEN AND PROGESTERONE RECEPTORS IN BREAST CANCER.

J. Dinny Graham, M. Greg Abel, Twila A. Jackson, David F. Gordon, William M. Wood and Kathryn B. Horwitz.

Division of Endocrinology, University of Colorado Health Sciences Center Denver, Colorado 80262, USA.

The antiestrogen tamoxifen is one of the most effective treatments for estrogen receptor (ER) positive breast cancer. However, tumors inevitably develop resistance to the treatment, which we postulated is due to the emergence of inappropriate agonist-like effects of this mixed antagonist. We have shown that the balance of agonist and antagonist activities of mixed antagonists is influenced by the abundance of nuclear receptor coregulators. We demonstrated that the corepressors N-CoR and SMRT, suppress the partial agonist activities of tamoxifen and the mixed antiprogestin RU486 on ER and progesterone receptor (PR), respectively. Furthermore, a novel coactivator, L7/SPA, enhances partial agonist activity. These effects are mixed antagonist-specific, and are not observed with agonists or pure antagonists. In addition, we found that the expression levels of these coregulators may differ between tamoxifen sensitive and resistant breast tumors, suggesting that they may be determinants of tamoxifen responsiveness. We postulated that other novel factors may play a specific role in determining mixed antagonist effects in breast cancer. We have employed two different antagonist-specific screening strategies to identify proteins involved in tamoxifen and RU486 action. Conventional yeast 2-hybrid screening was performed in the presence of RU486, with the hinge and hormone binding domain of PR as bait. We have identified a novel protein of approximately 109 kDa, which interacts with PR only when liganded to RU486. The protein contains eight nuclear receptor (NR) binding LXXLL domains. Mutagenesis of one out of two NR boxes, contained in the original 2-hybrid clone, resulted in loss of PR interaction with that fragment. The protein also contains three putative tetratricopeptide repeat domains, which may be involved in nuclear targeting of RU486-liganded PR and act as a scaffold for assembly of PR into multiprotein complexes. Recent evidence suggests that mixed antagonist-specific interactions with ER and PR involve multiple contacts with both AF-1 and AF-2 of the intact receptors. To screen for such proteins we have used a Sos recruitment 2-hybrid screening strategy with a full length ER bait, in the presence of tamoxifen. A number of antagonist-specific ER interacting proteins have been isolated and will be described.

Presented at **Proceedings of the International Congress on Endocrinology 2000, Sydney, Australia, 2000**

RECEPTOR INTERACTING PROTEINS AND THE FUNCTION OF PROGESTERONE AND ESTROGEN RECEPTORS IN BREAST CANCER

Graham JD, Abel MG, Gordon DF, Wood WM and Horwitz KB

Division of Endocrinology, University of Colorado Hlth Sc Ctr, Denver, Colorado 80262, USA.

The nuclear receptors for estrogen and progesterone (ER and PR) are important therapeutic determinants in breast cancer. Tumors expressing both receptors are generally well differentiated, indolent, and likely to respond to treatment with the mixed antiestrogen, tamoxifen. However, responsive tumors inevitably become tamoxifen-resistant and progress, often in the face of continued ER expression. We postulated that this is due to an increase in the partial agonist activity of tamoxifen. To test this hypothesis we have been searching for novel proteins that interact with receptors and modify the activities of mixed antagonists like tamoxifen. Using mixed antagonist-biased interaction screening, we have identified proteins that interact with ER and PR, and regulate transcription. The corepressors N-CoR and SMRT suppress the partial agonist activities of tamoxifen and the antiprogestin RU486, whereas the coactivator L7/SPA enhances this activity, yet has no effect on pure agonists or antagonists. In tamoxifen-resistant tumors removed from patients, we see a trend towards decreased expression of corepressors. In the same screen we identified a cDNA fragment encoding a novel protein, that we have now cloned and fully sequenced. The 109 kD protein interacts best with unliganded and mixed antagonist-bound PR, and less well with agonist-bound PR. The 944 amino acid protein sequence contains four nuclear receptor interaction LXXLL motifs. Additionally, there are three tetratricopeptide repeat (TPR) motifs in the N-terminus, characteristic of chaperonin/immunophilin binding proteins. Indeed, hsp90 also interacts with the protein strongly in protein interaction experiments. When expressed as a green fluorescent fusion protein, it shows a punctate cytoplasmic localization, which persists in the presence of progestins. We are testing the hypothesis that this protein has a scaffolding function, and plays an integral role in the correct expression and folding of nascent receptors, and perhaps their subcellular localization.

Conclusions:

We have identified novel progesterone receptor interacting proteins using an antagonist biased two-hybrid assay. These interacting proteins may be involved in the modification of the transcriptional activity of PR either as direct coregulatory proteins (ie. CBP/p300, N-CoR, and SMRT), as scaffolding proteins involved in the maturation of PR within the chaperonin/heat shock protein complex, and/or as protein folding modifiers that influence the affinity and type of ligand binding to the activated transcription factor. ORF#93p has been identified in a variety of tissues and cell lines and with the generation of a very good monoclonal antibody, the endogenous protein has been identified. A direct influence of ORF#93p on the activity of PR has not been demonstrated but it has been well established that ORF#93p specifically interacts with the C-terminus of PR and that the interaction is influenced by ligand binding. Future work will include the characterization of this hormone dependent interaction and the inclusion of a number of other known PR agonist and antagonist ligands. The nature of the role of ORF#93p in the maturation of PR within the chaperonin complex will be further elucidated using the hsp90 inhibitor geldanamycin. Comparisons between the isoforms of PR (PR-B, PR-A) and ORF#93p binding, influence of ORF#93p on activity of each

isoform using cell lines stably expressing either PR-B or PR-A, and ORF#93p recruitment of other auxiliary proteins to the chaperonin complex will be undertaken in the near future. Experiments to being the characterization of the PR interacters also isolated in the original two-hybrid screen (ORF#61 and ORF#127) are being discussed and preliminary data should be generated over the next 6-8 months.

Figure 1

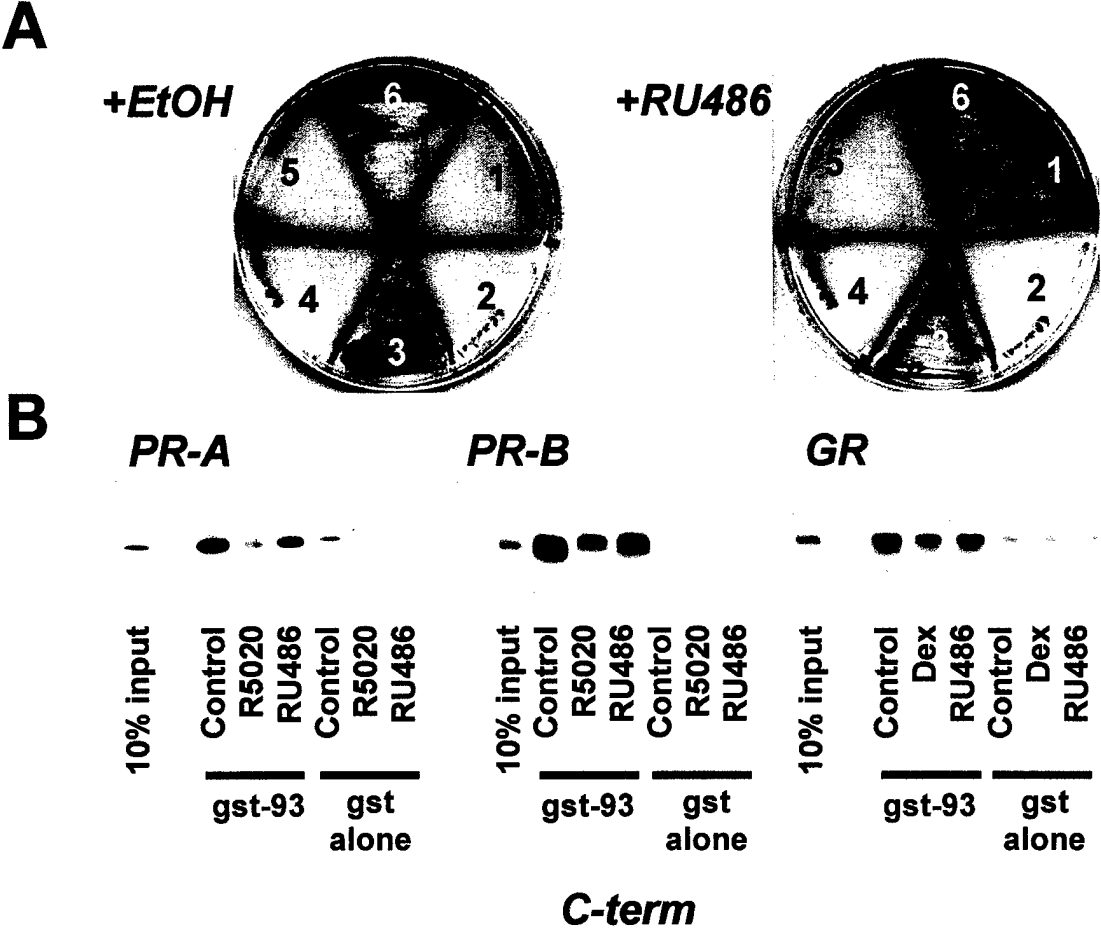

Figure 2

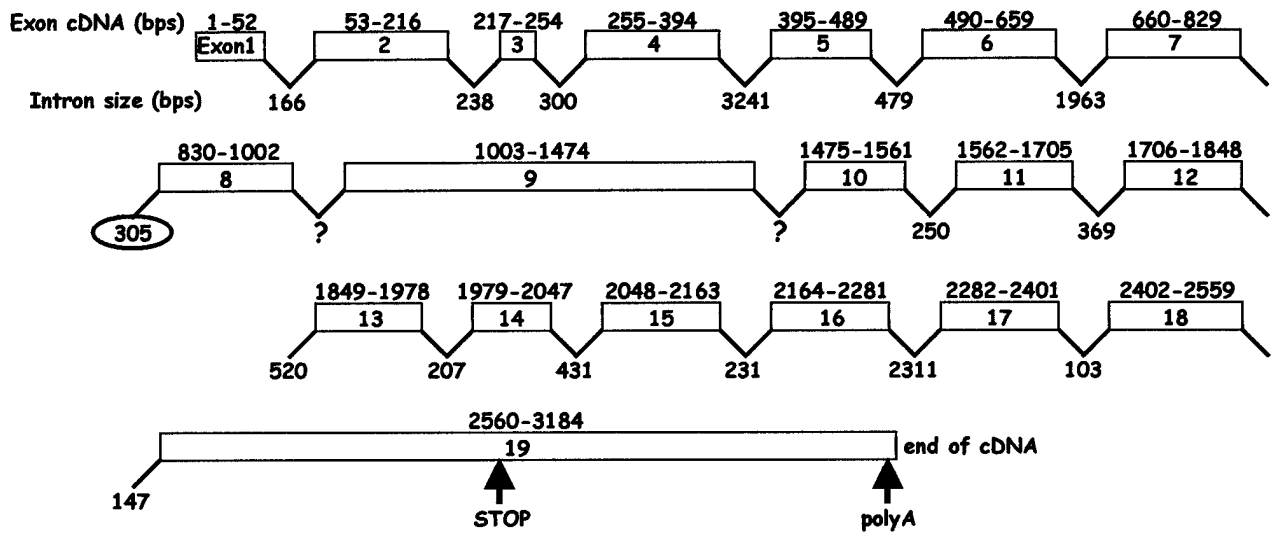
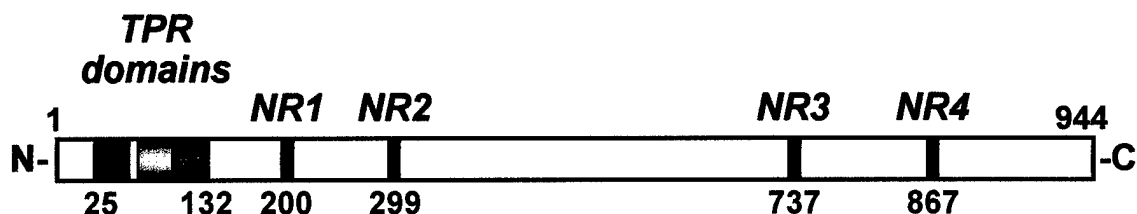
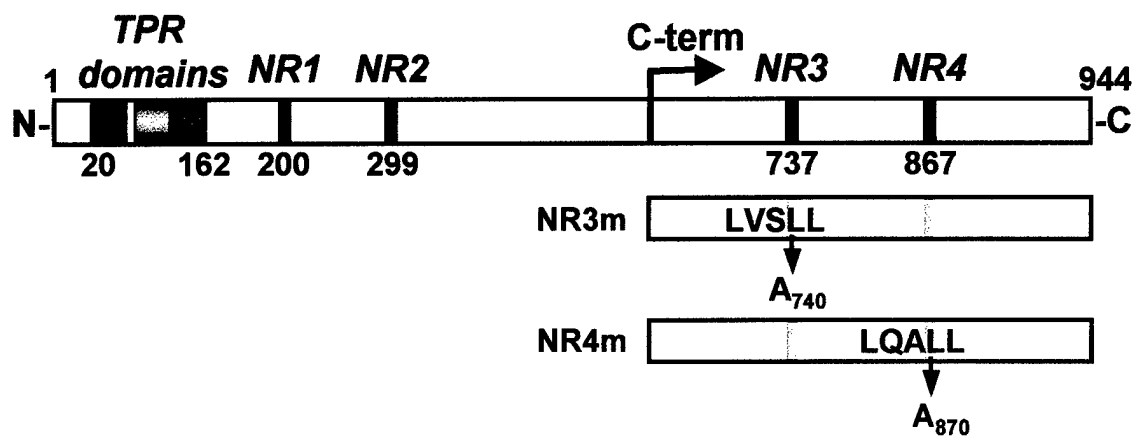

Figure 3



MTVSGPGTPE PRPATPGASS VEQLRKEGNE LFKCGDYGGA LAAYTQALGL
 DATPQDQAVL HRNRAACHLK LEDYDKAETE ASKAIEKDGG DVKALYRRSQ
 ALEKLGRLDQ AVLDLQRCVS LEPKNKVFQE ALRNIGGQIQ EKVRYMSSTD
 AKVEQMFQIL LDPEEKGTKE KQKASONLVV LAREDAGA EK IFRSNGVQLL
QRLLDMGETD LMLAALRTL V GICSEHQ SRT VATLSILGTR RVVSILGVES
 QAVSLAACHL LQVMFDALKE GVKKGFRGKE GAIIVDPARE LKVLISNLLD
LLTEVGVSGQ GRDNALTL LI KAVPRKSLKD PNNSLTLWVI DQGLKKILEV
 GGSLQDPPGE LAVTANSRMS ASILLSKLF D DLKCD AEREN FHRLCENYIK
 SWFEGQGLAG KLRAIQTVSC LLQGPCDAGN RALELSGVME SVIALCASEQ
 EEEQLVAVEA LIHAAGKAKR ASFITANGVS LLKDLYKCSE KDSIRIRALV
 GLCKLGSAGG TDFSMKQFAE GSTLKLAKQC RKWLCNDQID AGTRRWAVEG
 LAYLTFDADV KEEFVEDAAA LKALFQLSRL EERSVLFAVA SALVNCTNSY
 DYEEPDPKMV ELAKYAKQHV PEQHPKDKPS FVRARVKLL AAGVVSAMVC
 MVKTESPVL T SSCRELLSRV FLALVEEV E D RGTVVAQGGG RALIPLALEG
 TDVGQTKAAQ ALAKLTITSN PEMTFPGERI YEVVRPLVSL LHLNCSGLQN
 FEALMALTNL AGISERLRQK ILKEKAVPMI EGYMFEEHEM IRRATECMC
 NLAMSKEVQD LFEAQGNDR L KLLVLYSGED DELLQRAAAG GLAMLTSMRP
 TLCSRIPQVT THWLEILQAL LLSSNQELQH RGAVVVLNMV EASREIASTL
 MESEMMEILS VLAKGDHSPV TRAAAACLDK AVEYGLIQPN QDGE

Figure 4



	<i>Growth Rescue</i>		<i>Color Assay</i>	
	<i>RU 486</i> -	<i>RU 486</i> +	<i>RU 486</i> -	<i>RU 486</i> +
<i>C-term wt</i>	no	yes	no	yes
<i>NR3m</i>		no		no
<i>NR4m</i>		yes		yes
<i>none</i>	no	no	no	no

Figure 5

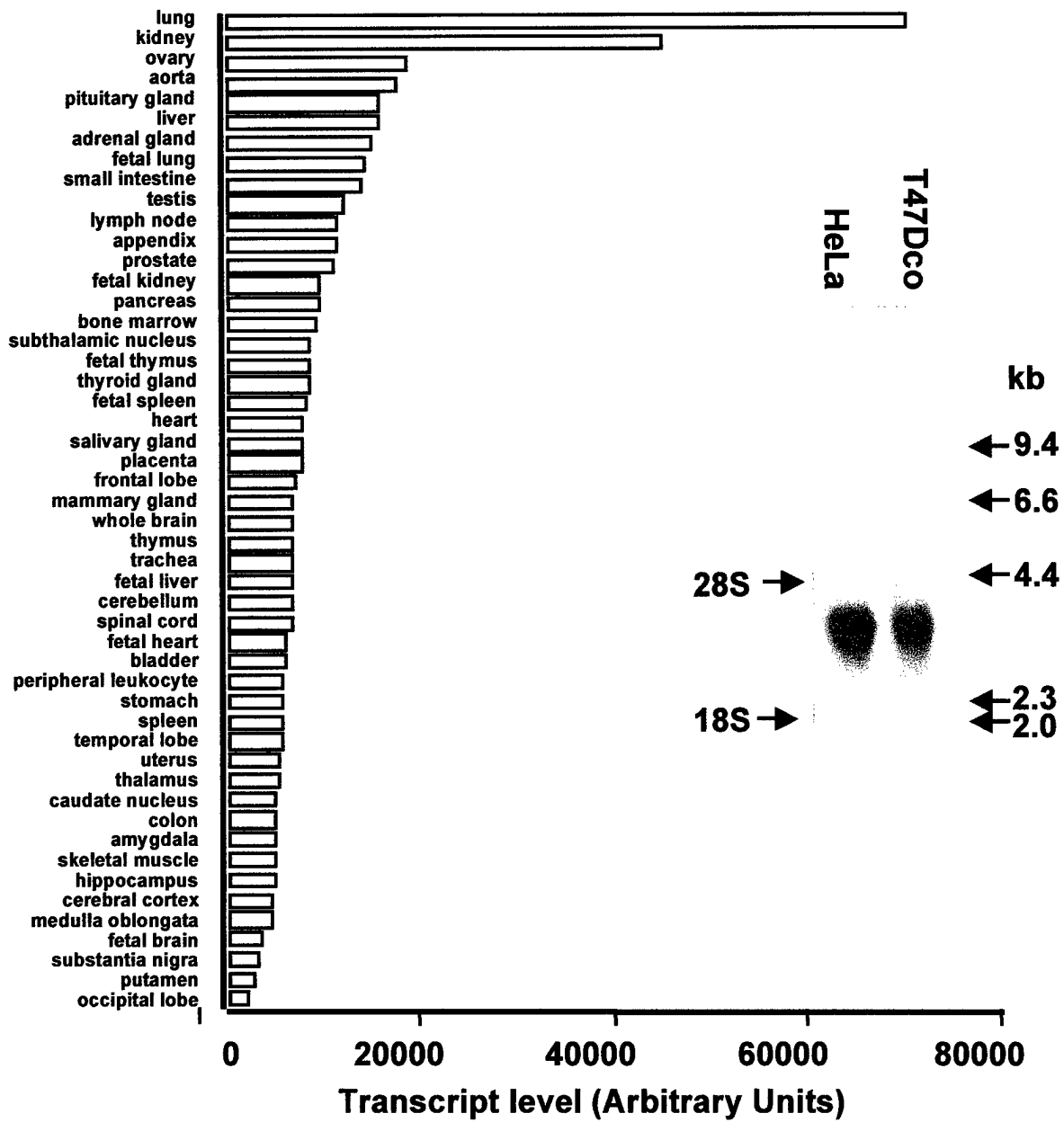

Figure 6

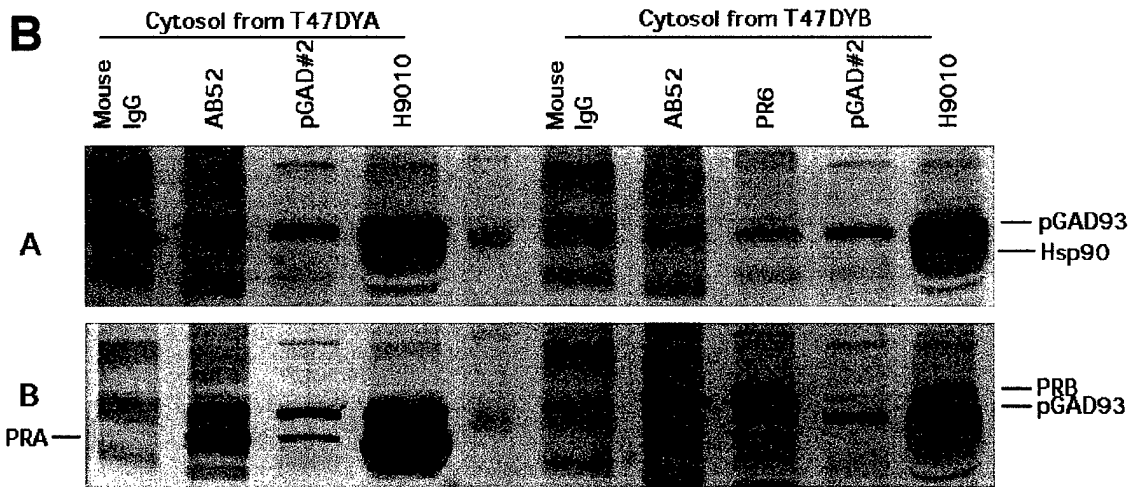
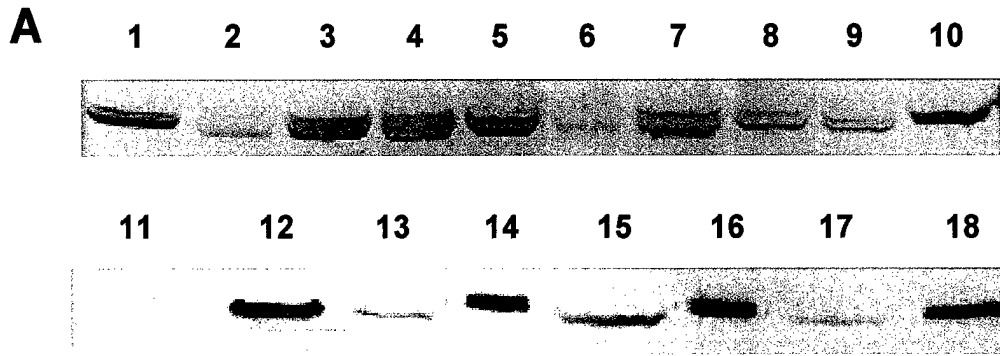
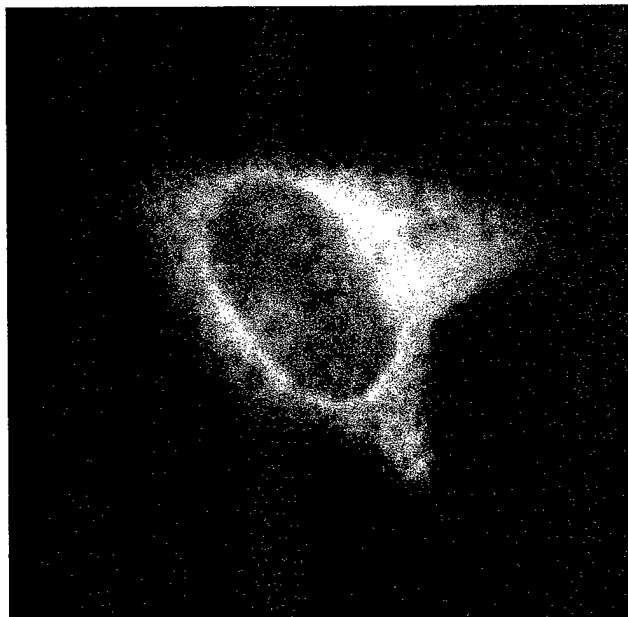

Figure 7

No hormone



10nM R5020



100nM RU486

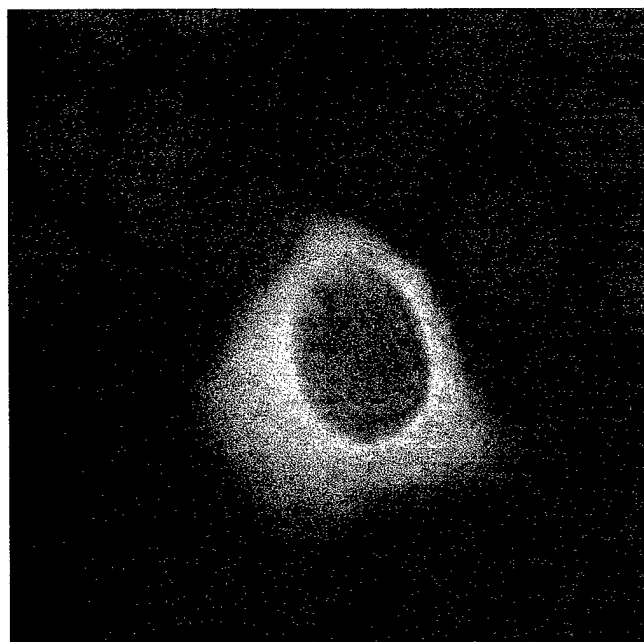

Green = GFP-ER-1A1

Blue = DAPI

Figure 8

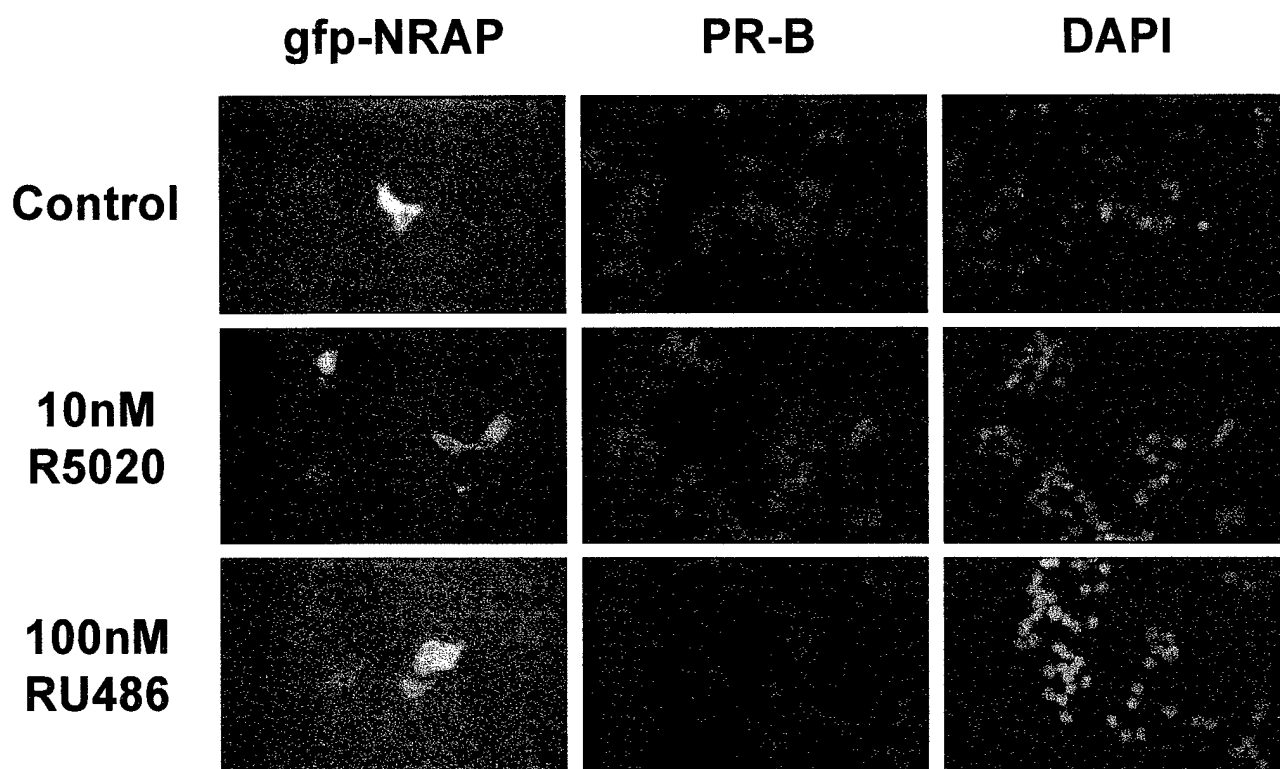

Figure 9

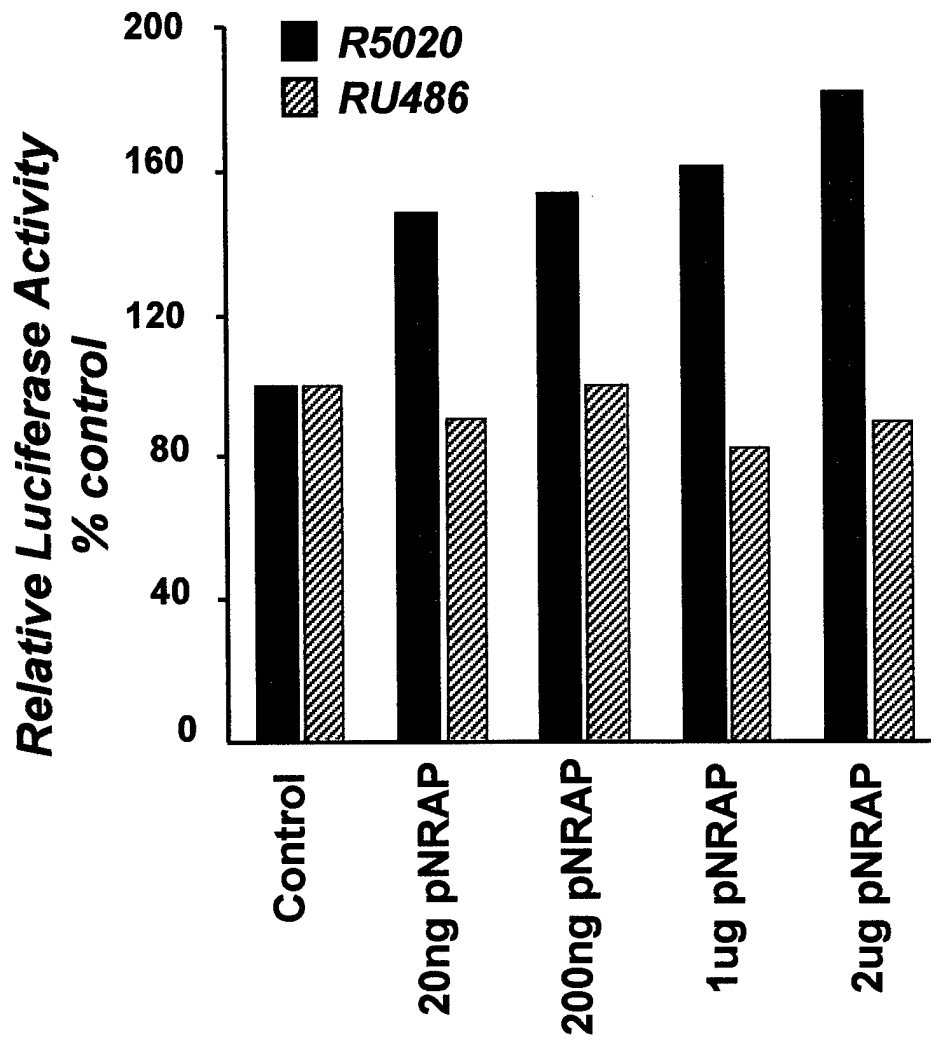

Figure 10

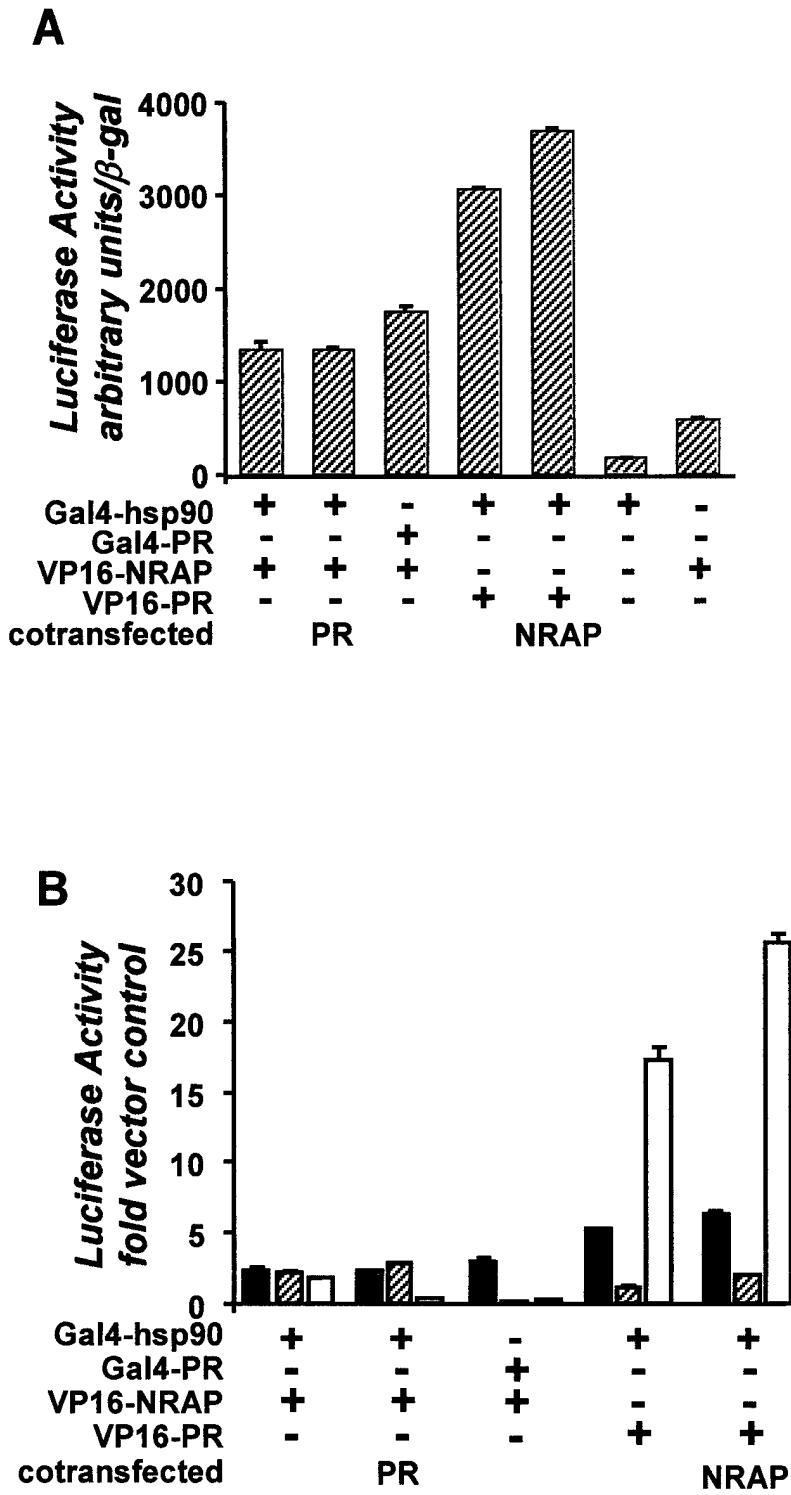

Figure 11

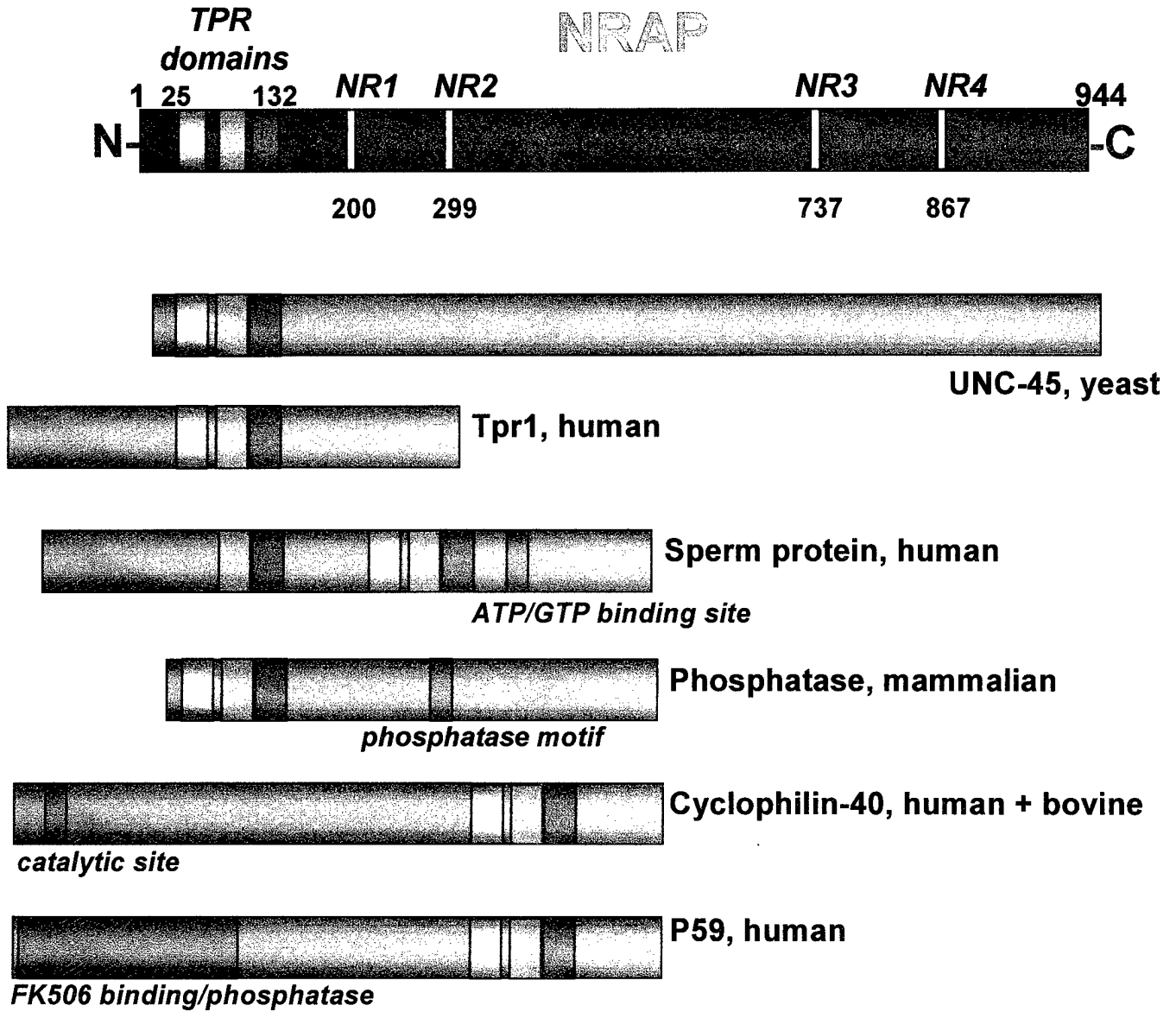

Figure 12

		W	L	G	Y		A	F	A	P						
		---	L	--	IA	--	L	-----	S	--	Y	--	S	----	K	--
		Y	M	S	F		E	L	L	E						
NRAP-TPR1:	20	VEQLRKEGNELEFKCGDYGGALAAYTQALGLDATP														
NRAP-TPR2:	92	VKALYRRSQALEKLGRLDQAVLDLQRCVSLEPKN														
NRAP-TPR3:	128	QEARLNIGGQIQEKVRYMSSTDAKVEQMFQILLD														
hCyp40:	223	TEDLKNIGNTFFKSONWEMAIKKYAEVRLRYVDSS														
bCyp40:	223	SEDLKNIGNTFFKSONWEMAIKKYTKVRLRYVEGS														
hPP5:	28	AELKIQANDYFKAKDYENAIKFYSQAIELNPSN														
ySTI1:	5	ADEYKQQGNAAF TAKDYDKAIELFTKAIEVSETP														
rFKBP52:	273	SAIVKERGTVYFEGKYKQALLQYKKIVSWLEYE														

Figure 13

