

USAARL Report No. 2003-03

Power Measurements for Microvision, Inc., Aircrew Integrated Helmet System Scanning Laser Helmet-Mounted Display

By Clarence E. Rash and Jessica A. Stelle (USAARL) and Thomas H. Harding (UES, Inc.)

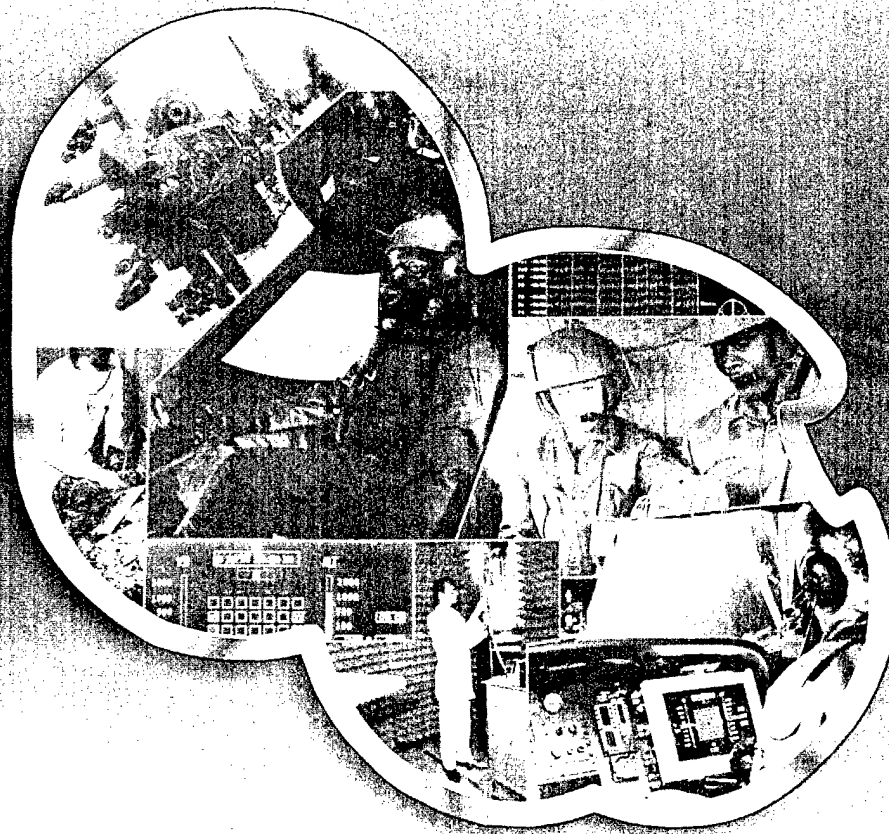

Aircrew Health and Performance Division

November 2002

Approved for public release, distribution unlimited.

20030213 023

U
S
A
A
R
L

U.S. Army
Aeromedical Research
Laboratory

Notice

Qualified requesters

Qualified requesters may obtain copies from the Defense Technical Information Center (DTIC), Cameron Station, Alexandria, Virginia 22314. Orders will be expedited if placed through the librarian or other person designated to request documents from DTIC.

Change of address

Organizations receiving reports from the U.S. Army Aeromedical Research Laboratory on automatic mailing lists should confirm correct address when corresponding about laboratory reports.

Disposition

Destroy this document when it is no longer needed. Do not return it to the originator.

Disclaimer

The views, opinions, and/or findings contained in this report are those of the author(s) and should not be construed as an official Department of the Army position, policy, or decision, unless so designated by other official documentation. Citation of trade names in this report does not constitute an official Department of the Army endorsement or approval of the use of such commercial items.

Unclassified

SECURITY CLASSIFICATION OF THIS PAGE

REPORT DOCUMENTATION PAGE				<i>Form Approved OMB No. 0704-0188</i>	
1a. REPORT SECURITY CLASSIFICATION Unclassified			1b. RESTRICTIVE MARKINGS		
2a. SECURITY CLASSIFICATION			3. DISTRIBUTION / AVAILABILITY OF REPORT Approved for public release, distribution unlimited		
2b. DECLASSIFICATION / DOWNGRADING					
4. PERFORMING ORGANIZATION REPORT NUMBER(S) USAARL Report No. 2003-03			5. MONITORING ORGANIZATION REPORT NUMBER(S)		
6a. NAME OF PERFORMING ORGANIZATION U.S. Army Aeromedical Research Laboratory		6b. OFFICE SYMBOL <i>(If)</i> MCMR-UAD	7a. NAME OF MONITORING ORGANIZATION U.S. Army Medical Research and Materiel Command		
6c. ADDRESS <i>(City, State, and ZIP Code)</i> P.O. Box 620577 Fort Rucker, AL 36362-0577			7b. ADDRESS <i>(City, State, and ZIP Code)</i> 504 Scott Street Fort Detrick, MD 21702-5012		
8a. NAME OF FUNDING / SPONSORING ORGANIZATION		8b. OFFICE SYMBOL <i>(If)</i>	9. PROCUREMENT INSTRUMENT IDENTIFICATION NUMBER		
8c. ADDRESS <i>(City, State, and ZIP Code)</i>			10. SOURCE OF FUNDING NUMBERS		
			PROGRAM ELEMENT NO. 62787A	PROJECT NO.	TASK NO.
11. TITLE <i>(Include Security Classification)</i> (U) Power Measurements for Microvision, Inc., Aircrew Integrated Helmet System Scanning Laser Helmet-Mounted Display					
12. PERSONAL AUTHOR(S) Clarence E. Rash, Jessica A. Stelle, Thomas H. Harding					
13a. TYPE OF REPORT Final		13b. TIME COVERED FROM TO		14. DATE OF REPORT <i>(Year, Month,</i> 2002 November	15. PAGE COUNT 11
16. SUPPLEMENTAL NOTATION					
17. COSATI CODES			18. SUBJECT TERMS <i>(Continue on reverse if necessary and identify by block number)</i> scanning laser helmet-mounted display (HMD), laser safety, Aircrew Integrated Helmet System (AIHS)		
FIELD	GROUP	SUB-GROUP			
01	02				
24	07				
19. ABSTRACT <i>(Continue on reverse if necessary and identify by block number)</i> Program Manager, Aircrew Integrated Systems (PM-ACIS) is developing a new helmet-mounted display (HMD) technology based on scanning lasers. Under this program, Microvision, Inc., Bothell, Washington, has developed a scanning laser HMD prototype for use with the Aircrew Integrated Helmet System (AIHS) Helmet Gear Unit - 56/P (HGU-56/P). As part of a comprehensive laser safety evaluation plan, power measurements of the prototype system were made at the design eye position for both normal and failure modes. For normal operation, right eye and left eye measurements of 1.48 and 1.58 microwatts were obtained. For total scanner failure, a value of 77 microwatts was obtained.					
20. DISTRIBUTION / AVAILABILITY OF			21. ABSTRACT SECURITY CLASSIFICATION		
<input checked="" type="checkbox"/> UNCLASSIFIED/UNLIMITED <input type="checkbox"/> SAME AS RPT. <input type="checkbox"/> DTIC USERS			Unclassified		
22a. NAME OF RESPONSIBLE INDIVIDUAL Chief, Science Support Center			22b. TELEPHONE <i>(Include Area</i> (334) 255-6907		22c. OFFICE SYMBOL MCMR-UAX-SS

Acknowledgments

The authors wish to thank the following Microvision personnel for their patience and expertise in the performance of power measurements: Jack Clevenger, Baldwin Ng, Bill Johnson, Karl Bylund, Matt Jakuc, Minhua Liang and Mircea Bayer.

Table of contents

	<u>Page</u>
Introduction	1
The Microvision scanning laser HMD	1
Methodology and results.....	4
Discussion and conclusions	6
References.....	7
Appendix.....	8

List of figures

1. Microvision prototype scanning laser HMD	2
2. An artist's conception depicting the ability of scanning laser HMDs to present symbology of sufficient luminance to be seen against daytime backgrounds	2
3. Functional block diagram of scanning laser HMD system	3
4. Flow diagram for optical path of laser energy	4

List of tables

1. Summary of requirements for AIHS scanning laser HMD.....	2
2. Laser specifications	3

Introduction

The U.S. Army under the auspices of the Program Manager, Aircrew Integrated Systems (PM-ACIS), has funded the development of a scanning laser helmet-mounted display (HMD). This system is being manufactured by Microvision, Inc., Bothell, Washington. This HMD is being designed for use with the Aircrew Integrated Helmet System (AIHS) Helmet Gear Unit 56/P (HGU-56/P) aviator helmet. The Microvision AIHS scanning laser HMD represents the first time that laser energy is purposely directed into the pilot's eyes as part of normal operation. Although this system is currently only in prototype phase, it has the potential of becoming a fielded system. In addition to ensuring that the system meets all standard laser related, hazard and safety requirements, there is an additional need to provide expanded information regarding safety to the Army aviation community in order to overcome engrained perceptions associated with directly viewing laser energy. In Rash and Harding (2002), a proposed laser safety evaluation plan was presented. One important element of this plan was to perform actual measurements of exposure power levels at the eye's position.

After providing a description and operational overview of the Microvision AIHS HMD system, this paper presents the results of actual power measurements made on the current prototype version during both normal and induced failure modes of operation.

The Microvision scanning laser HMD

Microvision is developing multiple HMD designs based on the technique of scanning lasers. The AIHS configuration, which is the system of concern herein, is a monochromatic design based on "green" lasers emitting at 532 nm. However, other ongoing designs incorporate red, green and blue lasers for full color applications; and appropriate laser hazard evaluations for these alternate configurations also will be addressed at future dates. Figure 1 presents the current prototype AHIS design. Figure 2, via an artist's conception, depicts the ability of scanning laser HMDs to present symbology of sufficient luminance to be seen against daytime backgrounds.

The AIHS scanning laser HMD design is intended for use in the Army rotary-wing environment. It is a monochromatic, binocular system that is required to provide a 52° horizontal by 30° vertical field-of-view (FOV) with a 30° overlap, a 15-millimeter (mm) exit pupil, and 25 mm of physical eye relief. It incorporates two 532 nm lasers, one per eye, operating in a bi-directional scanning mode. It has a requirement to provide luminance values in excess of 1200 footlamberts (fL). A summary of system requirements is provided in Table 1.

The current HMD system prototype consists of several primary components: an HMD comprised of a Pilot Retained Unit (PRU) (helmet) and an Aircraft Retained Unit (ARU) (Figure 1); an electronic and control module; interconnect cables and three lap top computers, two of which control imagery to the two HMD channels and a third which provides control of the electronic components; and a power supply that provides an external voltage source for controlling the HMD imagery luminance. Size and number of components continue to decrease as development continues.



Figure 1. Microvision prototype scanning Laser HMD.

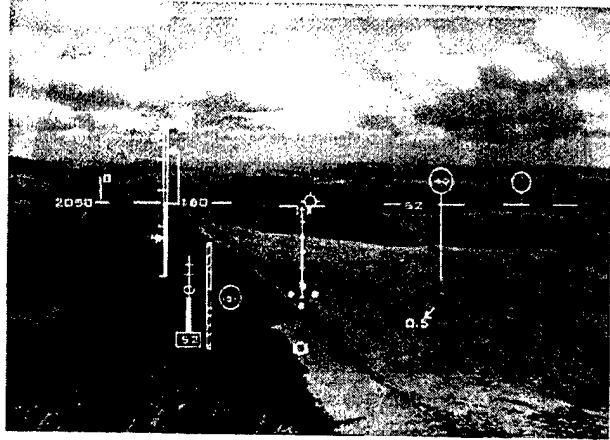

Figure 2. An artist's conception depicting the ability of scanning laser HMDs to present symbology of sufficient luminance to be seen against daytime backgrounds.

Table 1.

Summary of requirements for AIHS scanning laser HMD.

Parameter	Requirement
HMD Type	See-through
Color	Monochrome – Green
Configuration	Binocular
Field of view	52° x 30° (H x V)
Overlap	30° minimum
Resolution	1280 x 960
Luminance @ the eye	1200 fL
Exit pupil (On axis)	15 mm
Eye relief distance	25 mm
Helmet	HGU-56/P

As described previously, the AIHS system consists of two channels, one per eye. A functional block diagram of the system is provided in Figure 3. The diagram includes the power supply/management and drive (video processing) electronics subsystems, which are shared by the two channels, and those subsystems that are found in each channel: light source (photonics) module, fiber-optic cable, scanner assembly, exit pupil expander (EPE), and relay/viewing optics. Specifications for the operating parameters of the laser diode light sources are presented in Table 2.

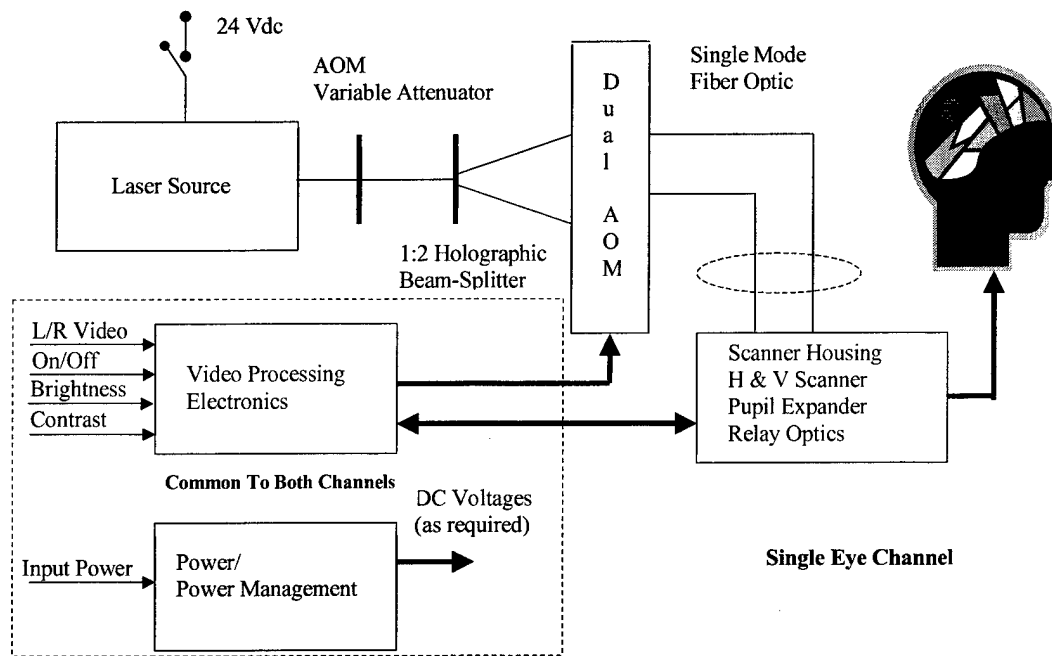

Figure 3. Functional block diagram of scanning laser HMD system.

Table 2.

Laser specifications.

Parameter	Specification
Wavelength	532 nm Green
Output power	100 mWatts
Spatial mode	TEM ₀₀
Roundness of beam	>95%, <1.1:1.0
Beam diameter (1/e ²)	0.32 ± 0.02 mm
Beam divergence	< 2.2 mrad

The functional block diagram in Figure 3 is useful for the understanding of the operation of the Microvision AIHS scanning laser HMD. For the purpose of this paper, to propose an approach and methodology to its laser safety evaluation, it may be more interesting and useful to look at the system from the perspective of how the laser light (energy) traverses the optical path from laser source to the eye. A flow diagram of this path is presented in Figure 4. This diagram is applicable to both channels. As can be seen, a theoretical power analysis predicts that only 0.48% of each laser's initial power reaches the eye.

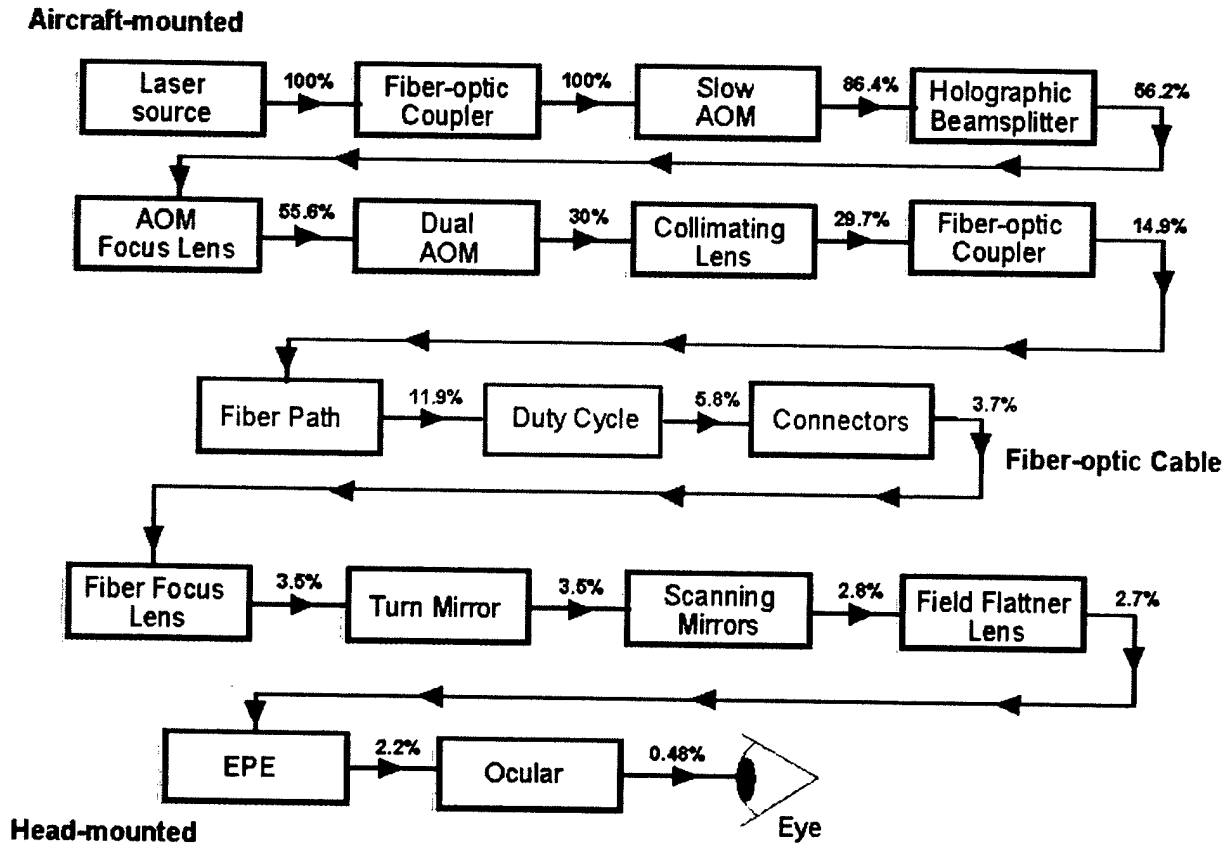

Figure 4. Flow diagram for optical path of laser energy.

Methodology and results

Measurements were conducted on 16-17 April 2002 at Microvision, Inc., Bothell, WA. Microvision personnel assisted in the operation of the AIHS system and test measurement setup. Measurements were performed for normal mode operation and for two identified failure scenarios, which were purposefully produced.

In previous discussions, the two possible major fault modes were identified as EPE failure and horizontal (mechanical resonance scanner (MRS)) and/or vertical (galvo) scanning failure. The function of the EPE is to expand the inherently small 1.5-mm exit pupil to the required 15-mm diameter circular exit pupil. Failure of the EPE would collapse the exit pupil back to the smaller size, increasing the power density on the exposed retinal area. However, it was agreed upon that the EPE failure has an extremely low probability and would occur only under conditions of water immersion or severe shock. Such conditions would be associated with damage that would result in total system failure. Therefore, the EPE failure mode was determined not to be of practical importance.

Failure of both scanners would collapse the laser energy to a pair of spots. While the energy entering the eye would remain the same, again there would be an increase in the power density

on the exposed retinal area. Microvision has integrated into the system hardware failsafe (HWFS) circuitry that monitors scanner output. The HWFS provides feedback signals to a timing card. If scanner feedback signals are not present or decrease below a preset level, power to the lasers is interrupted.

To duplicate the HWFS operation, fault injection was produced for both the MRS and galvo scanners. For duplication of the HWFS for a horizontal MRS failure, the power and feedback connector was mechanically removed. A digital storage oscilloscope was connected to the MRS feedback signal, to the HWFS low voltage detection circuitry, and to the output of a PIN photodiode detector that was monitoring the laser light output at the exit pupil position. The oscilloscope was triggered by the fault injection. Two time values were measured from the captured oscilloscope image. The first value was the time period from the fault injection to the failsafe detection. The second value was the time period from failsafe detection to a zero laser light output at the photodiode. This fault injection was performed six times. The range of values for the period of fault injection to failsafe detection was 840 microseconds (μs) to 1.34 milliseconds (ms). The range of values for the period of failsafe detection to total loss of laser output was 652-700 μs .

For a duplication of the HWFS for a vertical galvo failure, the scanner vertical sync signal was removed. Again, fault injection was performed six times. Each time, the value of the period between fault injection and failsafe detection was 6.32 ms. The values for the period between failsafe detection to a zero laser output were consistently 320 μs . However, the first value representing the period between fault injection and failsafe detection can range between practically zero to the frame period of 16.67 ms. The consistent 6.32 ms value obtained was due to the method of fault injection.

Therefore, the worst-case scanner failure is that of vertical galvo failure that would require up to 16.67 ms for detection and 320 μs for shutdown of laser output for a total of approximately 17 ms.

Following the demonstration of the implemented failsafe circuitry, actual power measurements were made at both eyes of the display, at the exit pupil location, for both normal operation and for total MRS and galvo scanner failure. For normal operation, measurements were made using an International Light model IL1700 Research Radiometer and SED033 silicon detector. A 7-millimeter (mm) iris and a 100-milliradian (mr) acceptance angle were used. The slow acoustic-optic modulator (AOM) used to attenuate the laser output and overall system brightness was set for maximum throughput. A full field pattern was used. For the right eye, two measurements of 1.48 and 1.46 microwatts (μW) were obtained. For the left eye, two measurements of 1.58 and 1.57 μW were obtained.

For the total scanner failure mode (MRS and galvo), measurements were made with a Newport integrating sphere and a model 1830-C Optical Power Meter, using a 7-mm aperture. The failure mode was achieved by bypassing the HWFS circuitry. A value of 77 μW was obtained.

Discussion and conclusions

The International Electrotechnical Commission (IEC) Class I radiance limit for extended viewing (>30,000 sec) of a scanned or modulated source is 23.6 mW/sr/cm². Based on the higher left eye power measurement of 1.58 microwatts, 7-mm aperture, and 100-mr acceptance angle, the calculated radiance is 0.523 mW/sr/cm². This results in a safety factor of 45. For total scanner failure and the unlikely event of the failure of the HWSF circuitry, the radiance based on the 77- μ W measurement would be 113,222 mW/sr/cm². The IEC Class I limit for continuous viewing time of 10 to 100 seconds is 573,464 mW/sr/cm². This results in a safety factor of 5.

Based on these measurements and the IEC classifications, this preliminary evaluation of the Microvision AIHS RSD shows this prototype to meet the requirements of a Class I laser system under both normal and failure (continuous source) mode operation. Class I is the safest classification of laser devices.

Microvision should be commended for their cooperation in the demonstration of the HWFS circuitry and the collection of the necessary power measurements. This exercise is part of a comprehensive laser safety evaluation being coordinated by USAARL (Rash and Harding, 2002).

Special note: The measurements and methodology presented in this paper are to be considered only as representative of the current prototype version of the Microvision AIHS scanning laser HMD. The numbers reported here should not be construed as an acceptance of this system. The U.S. Army Center for Health Promotion and Preventive Medicine (USACHPPM), Aberdeen Proving Grounds, MD, is the responsible U.S. Army agency for the verification of laser devices.

References

International Electrotechnical Commission (IEC). 2001. Safety of laser products – Part 1: Equipment classification, requirements, and user's guide. IEC 60825-1 (2001 Revision).

Rash, C.E., and Harding, T.H. (2002). A proposed laser safety evaluation plan for the Microvision, Inc, Scanning Laser Helmet-Mounted Display System. Fort Rucker, AL: U.S. Army Aeromedical Research Laboratory. USAARL Report No. 2003-01.

Appendix.

List of manufacturers.

International Light, Inc.
17 Graf Road
Newburyport, Massachusetts 01950-4092

Newport Corporation
1791 Deere Avenue
Irvine, CA 92606