

REPORT DOCUMENTATION PAGE

Form Approved
OMB No. 0704-0188

Public reporting burden for this collection of information is estimated to average 1 hour per response, including the time for reviewing instructions, searching existing data sources, gathering and maintaining the data needed, and completing and reviewing this collection of information. Send comments regarding this burden estimate or any other aspect of this collection of information, including suggestions for reducing this burden to Department of Defense, Washington Headquarters Services, Directorate for Information Operations and Reports (0704-0188), 1215 Jefferson Davis Highway, Suite 1204, Arlington, VA 22202-4302. Respondents should be aware that notwithstanding any other provision of law, no person shall be subject to any penalty for failing to comply with a collection of information if it does not display a currently valid OMB control number. PLEASE DO NOT RETURN YOUR FORM TO THE ABOVE ADDRESS.

1. REPORT DATE (DD-MM-YYYY)	2. REPORT TYPE Technical Paper	3. DATES COVERED (From - To)
------------------------------------	--	-------------------------------------

4. TITLE AND SUBTITLE	5a. CONTRACT NUMBER
	5b. GRANT NUMBER
	5c. PROGRAM ELEMENT NUMBER

6. AUTHOR(S)	5d. PROJECT NUMBER 2306
	5e. TASK NUMBER M1B3
	5f. WORK UNIT NUMBER 343120

7. PERFORMING ORGANIZATION NAME(S) AND ADDRESS(ES)	8. PERFORMING ORGANIZATION REPORT
---	--

9. SPONSORING / MONITORING AGENCY NAME(S) AND ADDRESS(ES) Air Force Research Laboratory (AFMC) AFRL/PRS 5 Pollux Drive Edwards AFB CA 93524-7048	10. SPONSOR/MONITOR'S ACRONYM(S)
	11. SPONSOR/MONITOR'S NUMBER(S)

12. DISTRIBUTION / AVAILABILITY STATEMENT

Approved for public release; distribution unlimited.

13. SUPPLEMENTARY NOTES

14. ABSTRACT

20030128 087

15. SUBJECT TERMS

16. SECURITY CLASSIFICATION OF:			17. LIMITATION OF ABSTRACT	18. NUMBER OF PAGES	19a. NAME OF RESPONSIBLE PERSON Leilani Richardson
a. REPORT Unclassified	b. ABSTRACT Unclassified	c. THIS PAGE Unclassified			19b. TELEPHONE NUMBER (include area code) (661) 275-5015

2306/mj B3

MEMORANDUM FOR PRS (In-House Publication)

FROM: PROI (STINFO)

13 Apr 2001

SUBJECT: Authorization for Release of Technical Information, Control Number: **AFRL-PR-ED-TP-2001-086**
P.G. Wapner and W.P. Hoffman, "Partial Wetting of Non-Smooth Surfaces and Shaped Microchannels"

Science Journal
(Deadline: N/A)

(Statement A)

PARTIAL WETTING OF NON-SMOOTH SURFACES AND SHAPED MICROCHANNELS

Phillip G. Wapner and Wesley P. Hoffman

Abstract

Liquids traditionally described as non-wetting on a solid surface are shown, under certain conditions, to completely fill an interstice in an experimental apparatus fabricated from smooth plates made of the solid. The conditions controlling whether filling of the interstice takes place or not are demonstrated to be a function of both the liquid-solid contact angle and the included angle within the interstice. This behavior is both reversible and reproducible. A simple relationship is developed to express the critical included angle as a function of contact angle. A symmetrical theory also appears to apply to capillary flow of wetting fluids.

Text

Recently, there has been a great deal of interest in the phenomenon of wettability as it applies to numerous fields. In particular, increasing attention is being given to partial wetting of micro-channels in MEMS micro-fluidic devices. Examples are pressure sensors and accelerometers (1) and so-called "labs on a chip" which perform chemical analyses (2-8). The behavior of liquids that have contact angles with a solid surface greater than zero but less than 180 degrees is also relevant to many other technologies, including adhesion, adsorption, lubrication, catalysis, and solid-liquid reaction kinetics. Moreover, when the solid surface is not perfectly smooth, liquid contact with that surface is poorly understood and the subject of considerable misconception. It is the purpose of

this article to report on experimental and theoretical observations that hopefully contribute to a better understanding of this complex phenomenon.

The field of MEMS devices has enlarged technologically in the last few years to include optical as well as fluidic components in their makeup. These additional working elements are evolving in much the same way as the original MEMS devices evolved. That is, as reduction from macro-sized to micro-sized applications takes place, a reappraisal of the relative magnitudes of parameters controlling the operation of such working elements must be undertaken. Optic elements in MEMS devices, for example, behave very differently when the wavelength of radiation involved is the same order of magnitude as the size of the working elements themselves. The same is certainly true for micro-fluidic devices. Surface tension and wettability are parameters that can safely be ignored in most macro-sized fluidic applications. The reason for this is that forces due to viscous flow and static gravitational head are usually several orders of magnitude greater than forces due to surface tension and wettability. This is a direct consequence of the relationship derived by Young (9) and Laplace (10) for the pressure difference, ΔP_s , across a curved liquid surface, the two possible radii of curvature of that surface, r_1 and r_2 , and surface tension of the liquid, γ :

$$\Delta P_s = \gamma(1/r_1 + 1/r_2)$$

However, whenever either radius of curvature approaches micron-sized the pressure difference across the curved surface can no longer be ignored. This is certainly the case in capillary flow.

Wettability enters into the process at this point with the derivation by Washburn (11) for the relationship between the pressure, P_c , needed to either force a liquid into or expel it from a capillary, the contact angle of the liquid with the capillary wall, θ , and capillary radius, r_c :

$$P_c = 2\gamma\cos\theta/r_c \quad (2)$$

It is assumed, for the discussion that follows, that the radius of the capillary and the two possible radii of the curved liquid surface are all equal; i.e.:

$$r_1 = r_2 = r_c \quad (3)$$

When the contact angle is between zero and 90 degrees, the liquid is traditionally said to "wet" the capillary wall and it will enter the capillary on its own accord. Pressure is then needed to expel it from the capillary. If the contact angle is between 90 degrees and 180 degrees, the fluid is termed "non-wetting" and pressure is needed to force it into the capillary. This latter property is, of course, the basis for mercury porosimetry (12). It is also easy to demonstrate that this behavior can be employed to make a variety of sensing devices if the radius of the capillary is allowed to either increase or decrease in a controlled fashion rather than remaining constant. This is particularly true if the liquid is non-wetting (1). If a liquid has a contact angle of exactly 90 degrees, it would therefore not enter a capillary having a constant diameter of its own accord, and would not require pressure to insert it into the capillary. The slightest pressure would, however, cause the liquid to flow into and through the capillary and then out the other side. Only viscous forces would affect the rate of flow. The definitions of wetting and non-wetting were established precisely because of this sharp demarcation in behavior within capillaries of

liquids having contact angles of 90 degrees. That is, however, for capillaries having constant diameters.

When the capillary geometry is allowed to vary, however, the traditional concepts of wetting and non-wetting have to be carefully examined. This is true not only for varying axial geometries but also for non-circular radial geometries. In order to clarify this point, refer to Figures 1, 2, and 3, which illustrate an experiment that was performed in our laboratory. In Figure 1, a drop of mercury has been placed directly over the juncture of two horizontal glass plates. The plates were mounted in an apparatus designed to keep the upper edges of the plates firmly together during rotation thereby maintaining a sharp interstice. The mercury on the two horizontal plates forms a symmetric sessile drop having a contact angle of 140 degrees. In Figure 2, the right glass plate has been rotated through an angle of 45 degrees with the horizontal so that the included angle, ϕ , between the two plates is 135 degrees. The outer surface of the mercury drop has assumed a modified sessile-drop curvature, but the juncture between the two plates is still completely filled. In Figure 3, rotation has been continued until the included angle is 60 degrees. The outer surface is still asymmetric, but the interstice is no longer filled. The included angle at which the mercury drop withdraws from the interstice can be easily determined by referring to Figure 4, which is a schematic drawing of the unfilled corner in Figure 3.

Clearly, the three points labeled A, B, and C, would form an isosceles triangle except that the base, line A-B formed by the mercury drop, is curved. If, however, the included angle forming the unfilled corner was increased, at some point the contact angles tangents drawn in at points A and B would point directly at one another and the

line drawn between them would have to be straight. The radius of curvature, r_{un} , would then be infinite. However, this is not possible because equation (1) would then indicate that there is no pressure drop across that surface. Thus, whenever the included angle increases to the value where a straight meniscus would be formed in the unfilled interstice, pressure within the drop caused by surface tension forces push the drop into the interstice filling it completely. Because the sum of angles in a triangle is 180 degrees, the relationship defining this crossover angle, ϕ_c , is as follows:

$$180 = (180 - \theta) + (180 - \theta) + \phi_c$$

or
$$\phi_c = 2\theta - 180 \quad (\theta \geq 90^\circ) \quad (4)$$

Therefore, for a mercury drop having a contact angle of 140 degrees on glass, the theoretical crossover angle is 100 degrees. Experimentally, the included angle at which the drop first started exiting or entering the interstice was observed to be approximately 100 degrees, at least to within error limits of plus or minus several degrees caused by distortion in the optical system used to view the apparatus. Thus, anytime the included angle is less than 100 degrees, mercury no longer fills the interstice. In addition, the inner surface of the drop also moves further away from the interstice when the included angle is reduced below 100 degrees. This behavior was both reversible and reproducible, and gave similar results when both glass plates were rotated upwards forming a vertical interstice.

If mercury is replaced with another liquid that has a contact angle of 90 degrees with a solid, this correlation predicts a critical included angle of zero degrees. This liquid would certainly, therefore, completely fill any geometrical features on a surface, such as square or rectangular grooves, whose walls are parallel. Carrying this logic one step

further, it is reasonable to expect that surface texture or roughness created by fissures or pits whose sides possess an included angle greater than zero degrees will also be completely filled, even though 90 degrees is almost universally defined as the crossover contact angle between "wetting" and "non-wetting" behavior. It should be noted that equation (4) is independent of the actual dimensions of the walls forming the included angle. Thus, it is possible to fill any surface texture or roughness created by features whose sides form an included angle greater than zero degrees with either a "wetting", or a "non-wetting" liquid as long as the relationship in equation 4 is not exceeded.

The possibility that a liquid having a contact angle with a solid greater than 90 degrees can still completely fill, or "wet", non-smooth surface features under the right conditions is not reported in the literature to the authors' knowledge. In fact, quite the opposite viewpoint is oftentimes taken. A recent article by Russell and Kim (13) clearly shows a liquid having a contact angle less than 90 degrees, yet still not completely contacting a rough surface. Even the highly regarded physical chemistry text by Adamson (14) illustrates a drop on a rough surface having unfilled contours that should be filled because included angles in the illustration are less than 90 degrees. Moreover, drop surfaces within the contours are also shown as being flat. Certainly, a large body of literature has been written dealing with the concept of wettability (15-19). More than 50 years ago, Wenzel proposed using a roughness factor to explain, or at least correlate, wetting with surface roughness (20). The roughness factor he defined is the ratio of actual surface to geometric surface, the latter parameter simply being the "smooth surface" area. This actual, or non-smooth, surface area is usually equated with area measured by a gas adsorption technique, such as the BET technique (21). However,

since these techniques provide no knowledge about surface geometry, such as the included angle between surface non-uniformities, they are an inaccurate measure of the actual non-smooth surface in contact with liquids having contact angles greater than 90 degrees.

There have been independent confirmations in the literature of non-wetting droplets filling sharp corners, although the correlation presented in Equation (4) went unrecognized. An interesting solder technology developed to fabricate MEMS devices is a good example (22). Hinged components on a microchip are "popped up" by molten solder having a contact angle greater than 90 degrees. Molten solder droplets contained within self-assembling hinged corners illustrated in this article are virtually identical to those presented in the current study with mercury. Figure 5 illustrates the behavior of a mercury drop on a non-smooth surface fashioned from plates of glass ground to a 55 degree angle, and then placed back-to-back forming a surface with 110 degree included angles. The mercury clearly fills and contacts the entire surface, just as if it was "wetting" it.

Interestingly, this concept of "wetting" behavior by "non-wetting" liquids on a non-smooth solid surface can be extended in a symmetrical manner to capillary flow of liquids into small V-shaped openings when the liquids possess contact angles between zero and 90 degrees. When the included angle is greater than 180 degrees minus 2θ , fluid will not flow into the expanding V-shaped capillary from the base. Figures 6 and 7 illustrate the behavior of a reservoir of distilled water containing green food color into which two plates of Plexiglas® have been dipped. The same apparatus was used for this experiment as was used for the mercury-on-glass study. The contact angle of the colored

water on Plexiglas® is approximately 75 degrees, which therefore presages a critical included angle of 30 degrees. In Figure 6, colored water clearly does not enter an interstice having an included angle of 45 degrees. While in Figure 7, colored water does rise up into an interstice with a 5 degree included angle, demonstrating the expected classical capillary wetting action. While this experiment is much more difficult than the previous one, the results appear to corroborate the theory even though they were not nearly as reversible or reproducible. Considerable hysteresis was observed taking place. However, by gently vibrating the table upon which the apparatus was mounted, an equilibrium position of the water droplet within the Plexiglas® channel was rapidly reached which verified, to within experimental error, a 30 degrees critical included angle for this system.

In addition to providing a theoretical foundation for liquid behavior in symmetrical and non-symmetrical channels, the concepts presented here apply to many practical applications. One of these that provided the actual impetus for this experimental study, is the behavior of fluids in non-circular micro-channels. When a mercury droplet is placed in a horizontal tapered circular glass capillary, it can be pushed further into the taper with a slight amount of gas pressure. This forms a simple kind of micro-pressure-sensor (1). The reason gas pressure can perform this task is that the drop contacts the capillary wall completely, thereby sealing it. When, however, a tapered channel having the cross-sectional shape of a triangle, for example, is employed, the mercury does not completely fill all the vertices, and the gas does not remain sealed behind the drop. This prevents the sensor from working. It can be made to function again by switching to a fluid having a lower contact angle. If one wishes to seal a micro-channel having a cross-

section shape in the form of an equilateral triangle, for example, the contact angle must be less than 120 degrees. This is obtained by solving equation (4) for the contact angle when the included angle is 60 degrees. This is certainly relevant for micro-fluidic applications, since separation of liquid reactants, and even gases, can be performed using non-miscible liquids. These must, of course, possess the necessary contact angles to provide a complete seal.

Other technologies that may be affected by this concept include metallurgy and fabrication of metal-matrix composites because surface tension and contact angles are both very large for liquid metals. Zero gravity and micro-gravity situations will similarly be influenced because surface tension and wettability become controlling parameters when viscous flow ceases taking place in these environments. Finally, as mentioned previously, mercury porosimetry is closely associated with this behavior and may benefit from its application. If another liquid having a smaller contact angle, 120 degrees for example, is employed secondarily after mercury, any difference in data plots of intrusion volume versus pressure should be capable of interpretation by this phenomenon.

The financial support from Dr. Joan Fuller of the Chemistry and Materials Directorate, Air Force Office of Scientific Research is greatly appreciated.

References and Notes

1. P. Wapner, W. Hoffman, *Sensors and Actuators B* **3564**, 1 (2000)
2. News Focus, *Science*, **282**, 396 (1998)
3. D. J. Harrison *et al*, *Science*, **261**, 895 (1993)
4. M. W. J. Prins *et al*, *Science*, **291**, 277 (2001)
5. A Special Section of *Science*, **254**, 1300 (1991)

6. J. M. Ramsey *et al*, *Nature Medicine*, **1**, 1093 (1995)
7. S. C. Jacobson *et al*, *Anal. Chem.*, **68**, 720 (1996)
8. C. M. Henry, *C & EN*, 5 March, 36 (2001)
9. T. Young, *Trans. R. Soc. London*, **95**, 65 (1805)
10. P. S. de Laplace, *Mechanique Celeste, Suppl.*, 10 (1806)
11. E. W. Washburn, *Proc. Nat. Acad. Sci.*, **7**, 115 (1921)
12. S. W. Gregg, K. S. W. Sing, *Adsorption, Surface Area, and Porosity* (Academic Press, New York, 1982)
13. T. P. Russell, H. C. Kim, *Science*, **285**, 1219 (1999)
14. A. W. Adamson, *Physical Chemistry of Surfaces* (John Wiley & Sons, ed. 3, New York, 1976)
15. E. A. Vogler, chapter in preparation for *Water in Biomaterials Surface Science* (Edited by M. Morra for John Wiley & Sons)
16. V. V. Krotov, A. I. Rusanov, *Physicochemical Hydrodynamics of Capillary Systems* (Imperial College Press, London, 1999)
17. Surfactant Science Series, vol. 49, *Wettability* (Edited by J. C. Berg for Marcel Dekker, Inc., New York, 1993)
18. *Modern Approaches to Wettability: Theory and Applications* (Edited by M. E. Schrader and G. I. Loeb for Plenum, New York, 1992)
19. S. Gheorghiu, P. Pfeifer, *Phys. Rev. Letters*, **85**, No. 18, 3894 (2000)
20. R. N. Wenzel, *Ind. Eng. Chem.*, **28**, 988 (1936)
21. S. Brunauer, P.H. Emmett, and E. Teller, *J. Amer. Chem. Soc.*, **60**, 309 (1938)
22. K. F. Harsh *et al*, *Sensors and Actuators*, **77**, 237 (1999)

PHIL WAPNER
22 MAR 01

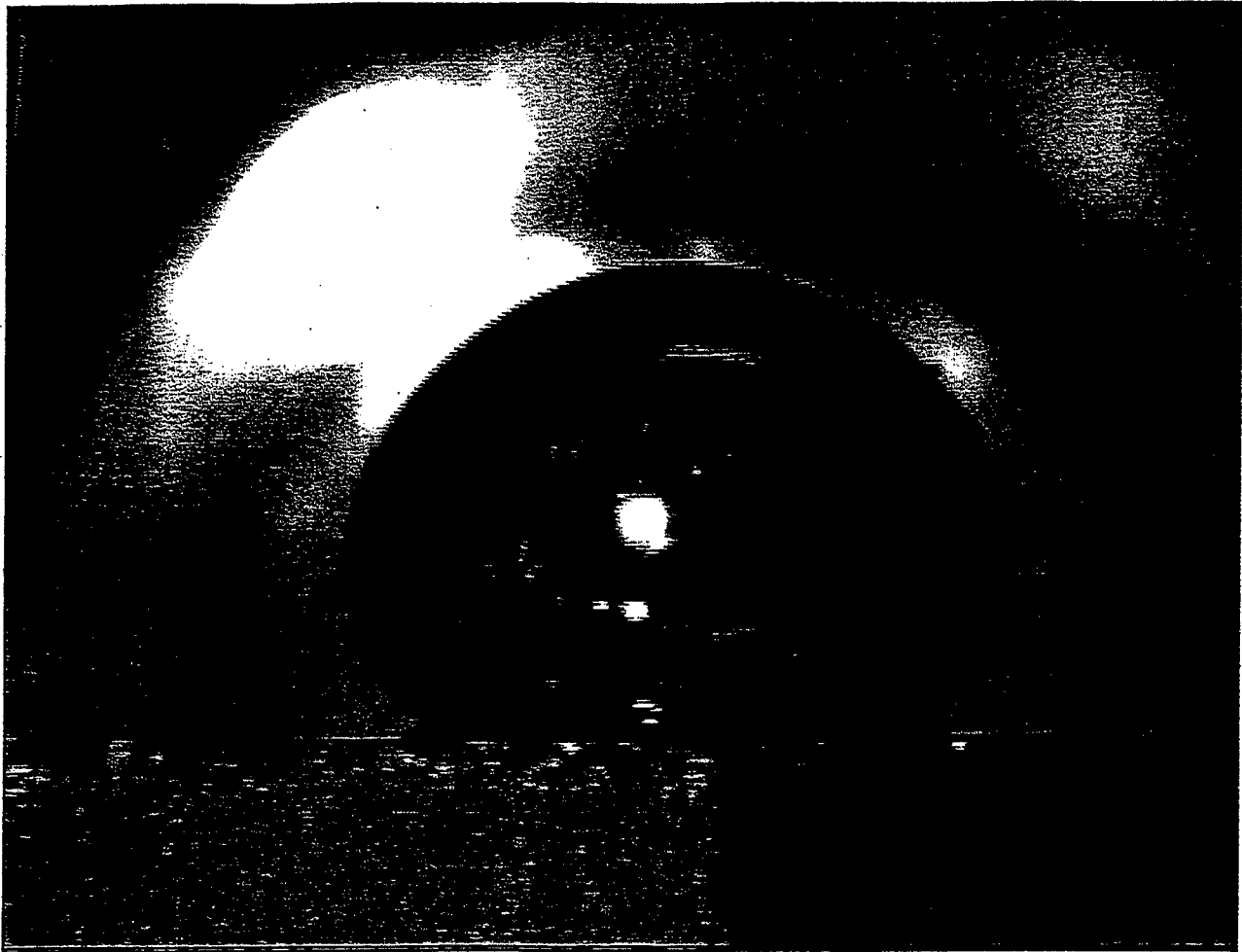

FIGURE 1

MERCURY

~~SPHERICAL~~ DROP
ON 180 DEGREE ~~CONTACT~~

VERTEX - COMPLETE FILLING

File => wettability_0001.BMP

PHIL WAPNER
22 MAR 01



FIGURE 2

~~STAR SHAPED MERCURY DROP~~
MERCURY
DROPS ON 135 DEGREE VERTEX -
↑
STILL COMPLETE FILLING

File => Wettability_0004.BMP

PHIL WARNER
22 MAR 01

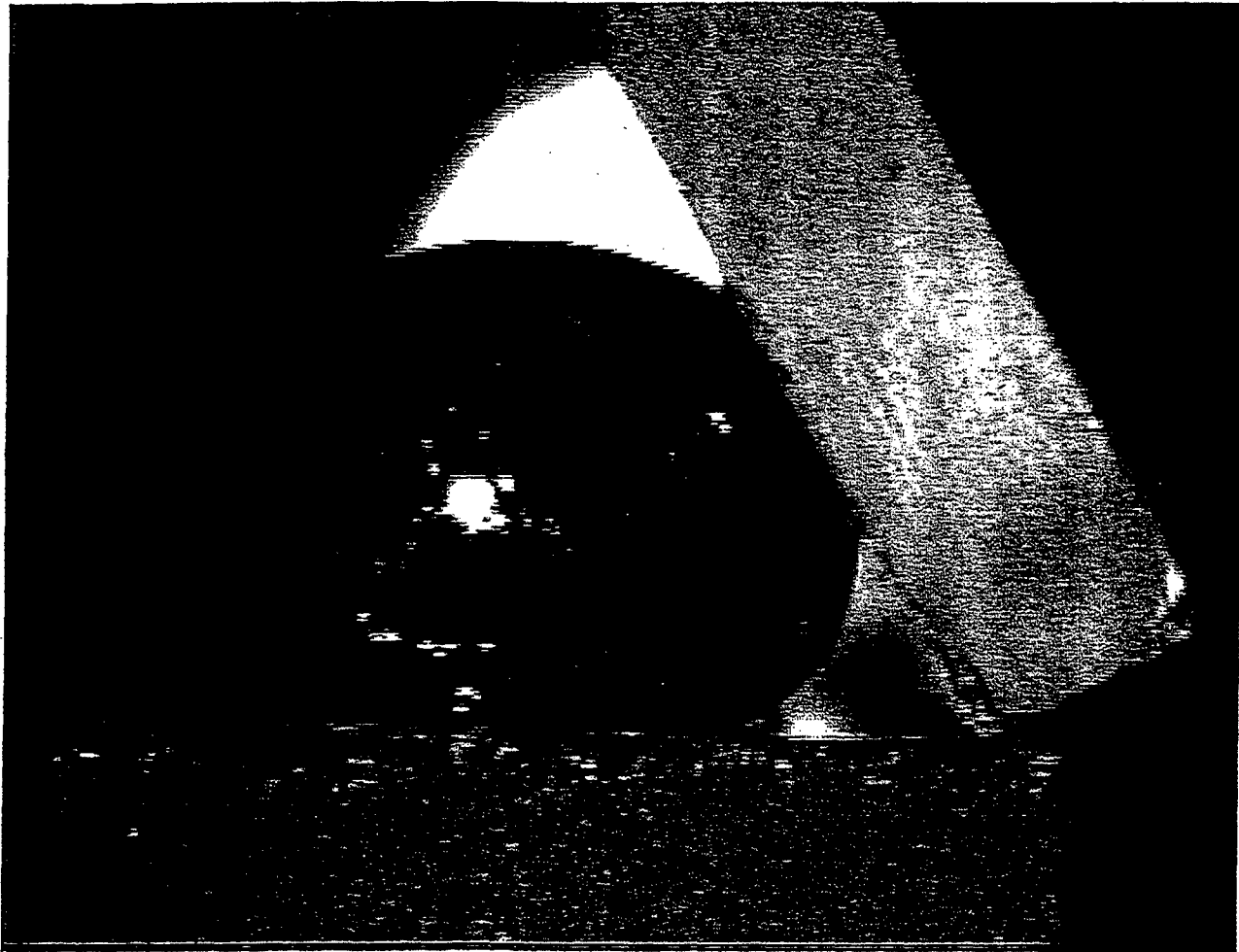
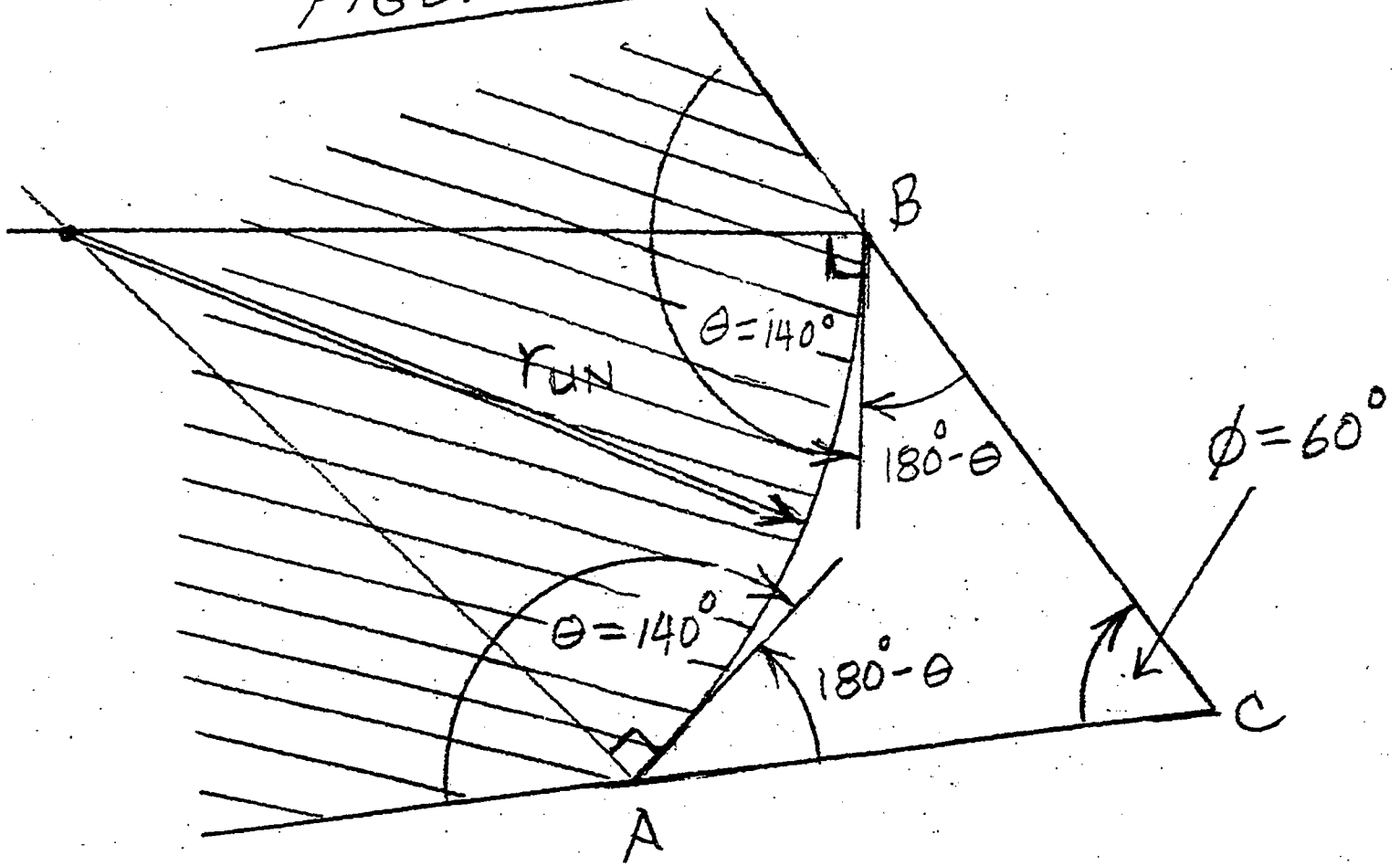

FIGURE 3

MERCURY DROP ON 60 DEGREE
VERTEX - INCOMPLETE FILLING

File \Rightarrow Wettability_0062.BMP

FIGURE 4



SCHEMATIC OF UNFILLED
VERTEX

PHIL WARNER

11 APR 01

FIGURE 5

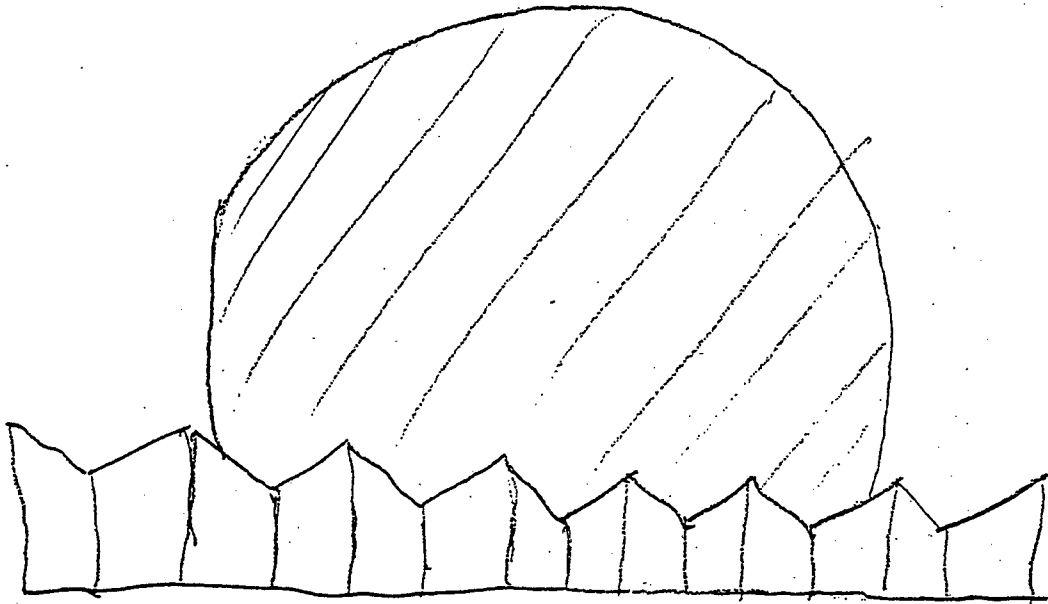

MERCURY DROP ON NON-SMOOTH
SURFACE HAVING 110° INCLUDED
ANGLE

22-141 50 SHEETS
22-142 100 SHEETS
22-144 200 SHEETS



PHIL WARNER
22 MAR 01

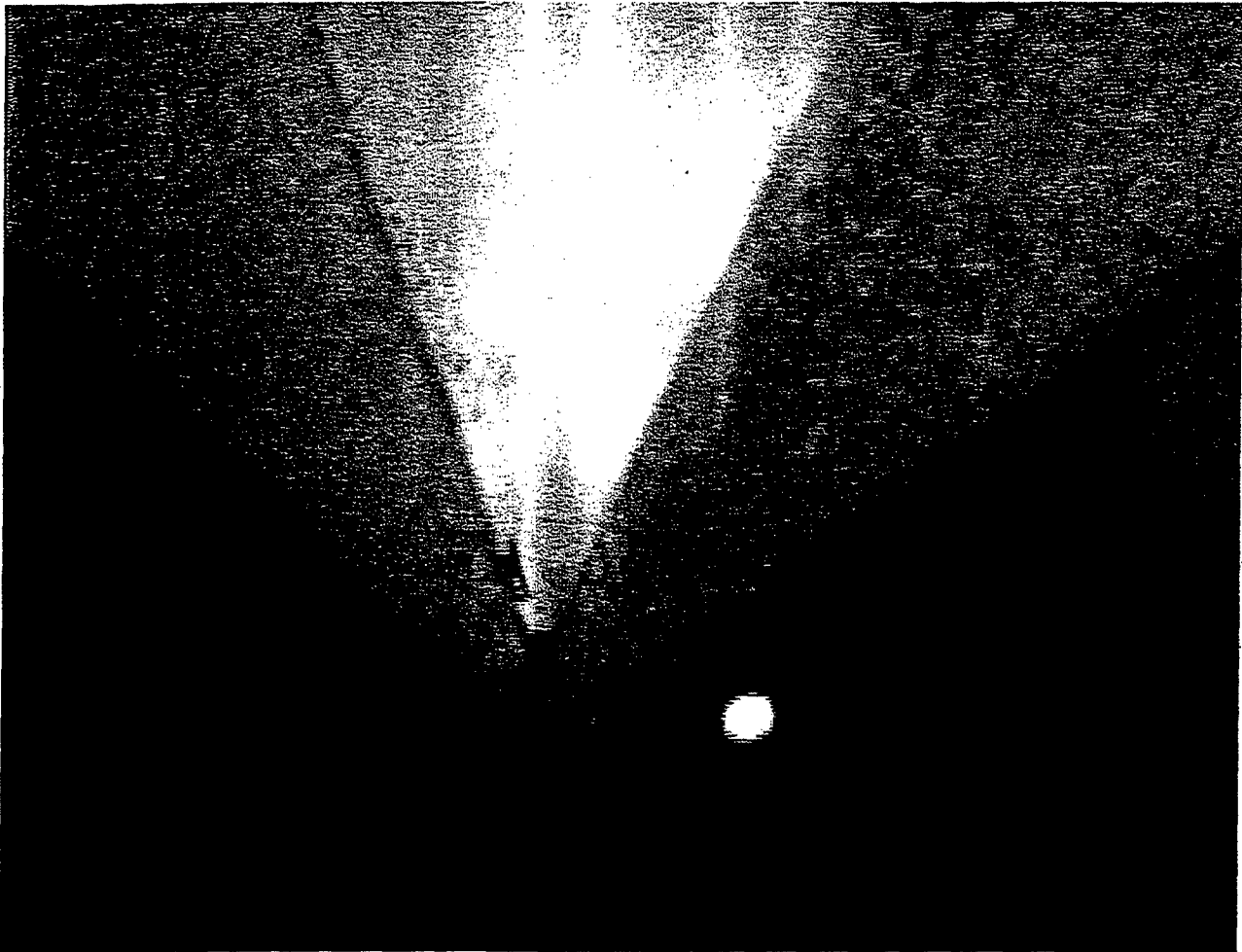

FIGURE 5

50 DEGREE VERTEX - NO
CAPILLARY FLOW OF WATER

File => wettability_0008.BMP

PHIL WAPNER
22 MAR 01

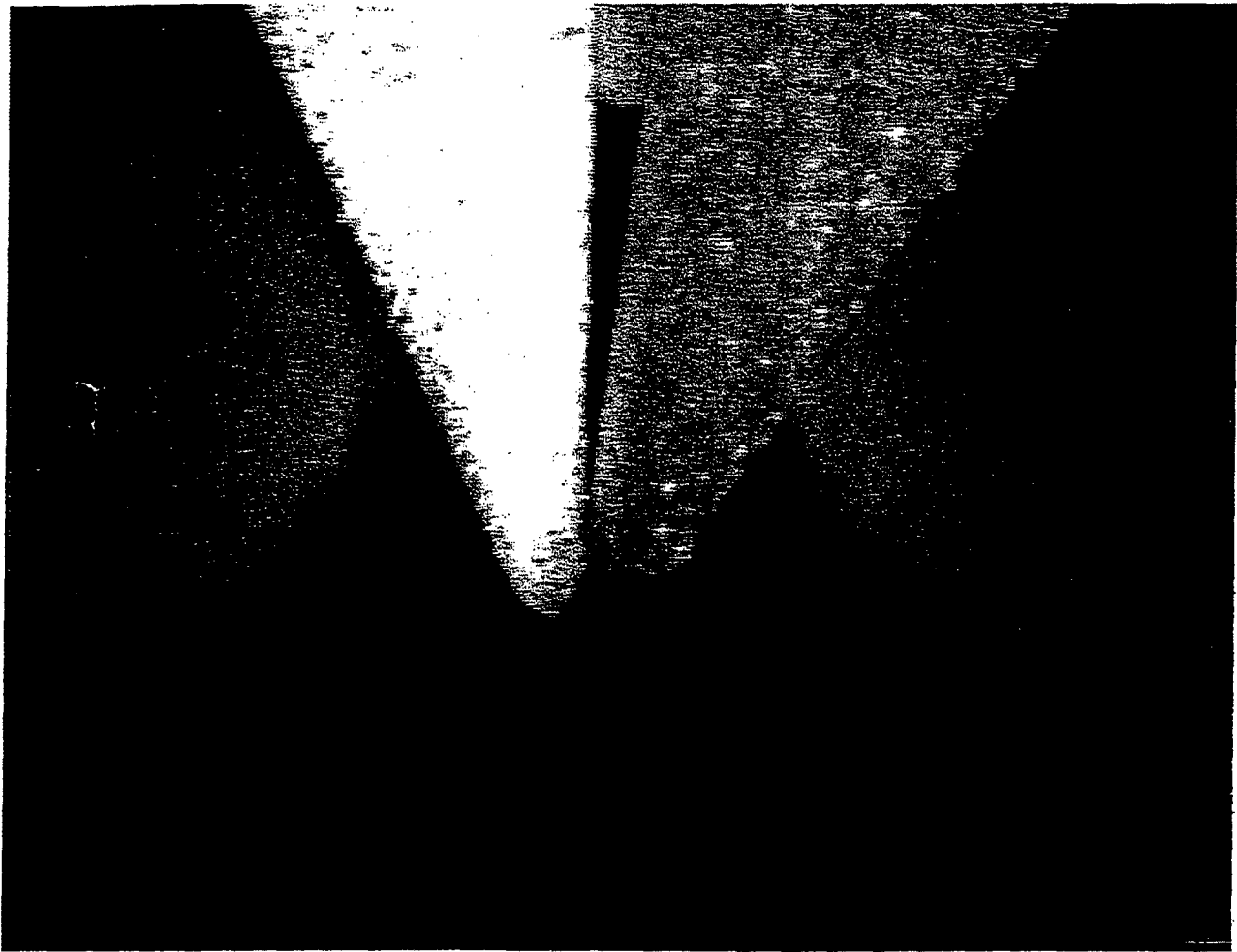

FIGURE 7

8 DEGREE VERTEX - ~~CAPOO~~

CONSIDERABLE CAPILLARY FLOW

OF WATER

File = 7 wettability 0012.BMP