



NAVAL FACILITIES ENGINEERING SERVICE CENTER
Port Hueneme, CA 93043-4370

Technical Memorandum TM-2357-AMP

AFTER ACTION REPORT

Freedom Banner – Cobra Gold 2002 Total Asset Visibility Experiment

by

Daniel J. McCambridge

Prepared for:

Office of Naval Research
Arlington, VA 22217-5660

December 2002

Approved for public release; distribution is unlimited.



Printed on recycled paper

The vendors and products identified in this report, including equipment, system components, and other materials are for information purposes only. Although the Navy/Marine Corps may have used these vendors and products in the past, mention in this report does not constitute the Navy's/Marine Corps' recommendation or endorsement of these vendors or products.

This page left blank.

REPORT DOCUMENTATION PAGE				Form Approved OMB No. 0704-0811	
<p>The public reporting burden for this collection of information is estimated to average 1 hour per response, including the time for reviewing instructions, searching existing data sources, gathering and maintaining the data needed, and completing and reviewing the collection of information. Send comments regarding this burden estimate or any other aspect of this collection of information, including suggestions for reducing the burden to Department of Defense, Washington Headquarters Services, Directorate for Information Operations and Reports (0704-0188), 1215 Jefferson Davis Highway, Suite 1204, Arlington, VA 22202-4302. Respondents should be aware that notwithstanding any other provision of law, no person shall be subject to any penalty for failing to comply with a collection of information, if it does not display a currently valid OMB control number.</p> <p align="center">PLEASE DO NOT RETURN YOUR FORM TO THE ABOVE ADDRESS.</p>					
1. REPORT DATE (DD-MM-YYYY) 16 December 2002		2. REPORT TYPE Final		3. DATES COVERED (From - To) April - May 2002	
4. TITLE AND SUBTITLE AFTER ACTION REPORT - Freedom Banner - Corba Gold 2002, Total Asset Visibility Experiment				5a. CONTRACT NUMBER	
				5b. GRANT NUMBER	
				5c. PROGRAM ELEMENT NUMBER	
6. AUTHOR(S) Daniel J. McCambridge				5d. PROJECT NUMBER	
				5e. TASK NUMBER	
				5f. WORK UNIT NUMBER	
7. PERFORMING ORGANIZATION NAME(S) AND ADDRESSES Amphibious and Expeditionary Department Expeditionary Systems Division Naval Facilities Engineering Service Center 1100 23 rd Avenue, Port Hueneme, CA 93044-4370				8. PERFORMING ORGANIZATION REPORT NUMBER TM-2357-AMP	
9. SPONSORING/MONITORING AGENCY NAME(S) AND ADDRESS(ES) Office of Naval Research Arlington, VA 22217-5660				10. SPONSOR/MONITORS ACRONYM(S)	
				11. SPONSOR/MONITOR'S REPORT NUMBER(S)	
12. DISTRIBUTION/AVAILABILITY STATEMENT Approved for public release; distribution is unlimited.					
13. SUPPLEMENTARY NOTES					
14. ABSTRACT This document describes an experimentation of technology that can bring the Marine Corps closer to the goal of achieving Total Asset Visibility. The venue used for this effort was the Freedom Banner/Cobra Gold 2002 exercise. This exercise was conducted in Thailand during April and May 2002. Several organizations were involved in the effort. The experiment had three objectives: (1) Provide the Third Force Service Support Group with technology that can enhance the TAV of equipment. (2) Identify and measure bandwidth parameters of the technology used to provide the TAV. This data will be used to compare this technology with the bar code scanning systems currently fielded in the Marine Corps. This data can also be used to evaluate sensor technologies that will be deployed in the battlefield. (3) Evaluate the capability to provide near real time visibility of deployed assets through existing or joint operational internet based systems. The three objectives were satisfied. Several conclusions and recommendations resulted from the effort. Total Asset Visibility technology has a significant impact on the Marine Corps process for offloading a Maritime Propositioning Ship. The impact is both a reduction in personnel required for the operation and in time required capturing data and providing information. The additional bandwidth burden resulting from the network traffic related to the technology was minimal. A residual was provided to the Third Force Service Support Group for the purposes of enhancing the visibility of their equipment.					
(1) Total asset visibility; bandwidth parameters; maritime propositioning ship, network traffic					
16. SECURITY CLASSIFICATION OF:			17. LIMITATION OF ABSTRACT	18. NUMBER OF PAGES	19a. NAME OF RESPONSIBLE PERSON
a. REPORT	b. ABSTRACT	c. THIS PAGE			19b. TELEPHONE NUMBER (include area code)
U	U	U	U	148	

This page left blank.

EXECUTIVE SUMMARY

This document provides a description of experimentation of technology that can bring the Marine Corps closer to the goal of achieving Total Asset Visibility. The venue used for this effort was the Freedom Banner / Cobra Gold 2002 exercise. This exercise was conducted in Thailand during April and May. Several organizations were involved in the effort. The experiment was performed at the request of BGEN Willie J. Williams, Commanding Officer, Third Force Service Support Group.

The experiment had three objectives:

- 1) Provide the Third Force Service Support Group with technology that can enhance the TAV of equipment.
- 2) Identify and measure bandwidth parameters of the technology used to provide the TAV. This data will be used to compare this technology with the bar code scanning systems currently fielded in the Marine Corps. This data can also be used to evaluate sensor technologies that will be deployed in the battlefield.
- 3) Evaluate the capability to provide near real time visibility of deployed assets through existing or joint operational internet based systems.

In order to measure the degree to which these objectives were achieved, several metrics were established and measured

The three objectives were satisfied. Several conclusions and recommendations resulted from the effort. Total Asset Visibility technology was demonstrated to have a significant impact on the Marine Corps process for offloading a Maritime Positioning Ship. The impact is both a reduction in personnel required for the operation and in time required capturing data and providing information. The additional bandwidth burden resulting from the network traffic related to the technology was minimal. A residual was provided to the Third Force Service Support Group for the purposes of enhancing the visibility of their equipment.

There is more work to be done. The scope of the experiment left questions unanswered. How will this technology perform under a full-scale Maritime Positioning Force operation? What are all of the commanders' requirements for information during a Maritime Positioning Force operation? What are the more global Marine Corps Total Asset Visibility requirements? These and other questions must be adequately answered in order to bring the technology solution to the Marine Corps that will truly add value and provide Total Asset Visibility.

This page left blank.

TABLE OF CONTENTS

	<u>Page</u>
FOREWORD	xiii
1. Introduction	1
2. Objectives	2
3. Background	3
3.1 Requirement	3
3.2 Challenge.....	4
4. Concept of Operations	4
5. Data Collection, Reduction and Analysis	4
5.1 Data Collection	4
5.2 Reduction & Analysis.....	5
5.2.1 Marine Corps Offload Process vs. RFID Technology.....	5
5.2.2 Information Systems: AVM and Army ITV.....	6
5.2.3 Network Analysis	10
6. Conclusions	12
7. Recommendations	13
8. Appendixes	1
Appendix A: CNA, UNISYS and SAIC After Action Reports	1
Appendix A1: CNA After Action Report	1
Appendix A2: Unisys After Action Report	1
Appendix A3: SAIC Iridium Report	1
Appendix B: Test Plan Documentation	1

TABLE OF CONTENTS (continued)

	Page
Appendix B1: Concept of Operations	1
1. CONOPS	1
1.1 Overview	1
1.2 MV WILLIAMS.....	2
1.3 Chuksamet Port.....	4
1.3.1 POG	4
1.3.2 MCC	7
1.3.3 LFSP	7
1.4 Samaesan	7
Appendix B2: System Setup and Operation	1
1. System Overview.....	1
2. RFID System.....	5
2.1 RFID Hardware	5
2.1.1 Tag Preparation and Installation	5
2.1.2 Frustrated Equipment Area.....	7
2.1.3 POG Entrance	7
2.1.4 MCC Exit	8
2.1.5 AAOE	8
2.1 Savi Asset Manager System Setup.....	9
3. Asset Viewer Manager (AVM).....	9
3.1 SAMS Client Agent Transfer (SCAT).....	9
3.2 AVM Database.....	9
3.3 Webserver	10
3.4 MDSS II Import/Export (MIE).....	10
4. Iridium Satellite Link.....	10
5. Network Monitoring.....	11
Appendix B3: Safety and Administrative	1
1. Safety and Administrative.....	1
1.1 Safety	1
1.2 Training	1
1.3 Roles and Responsibilities.....	1
Appendix B4: RFID and Iridium System/Component Description & Connections	1

TABLE OF CONTENTS (continued)

	Page
Appendix C: Data Collection	1
Appendix C1: Data Collection Procedure	1
1. General	1
2. Organic Marine Corps AIT Operations	1
3. RFID System Operations	2
4. Network Monitoring	2
Appendix C2: List of PEI to be Tagged (abbreviated)	1
Appendix D: Raw & Reduced Data	1
Appendix D1: List of PEI Tagged for Offload	1
Appendix D2: Selection of Completed Data Sheets	1
Appendix D3: Network Analysis Data	1
Appendix D4: AVM and Army ITV Screen Shots	1
Appendix E: Acronyms	1

This page left blank.

FOREWORD

This document describes the work that was performed by several organizations focusing on a common purpose – enhancing the Total Asset Visibility capability of the United States Marine Corps. The technology development that has been the result of previous efforts will be advanced further by the information gathered during this experiment. More importantly, this effort will contribute to the Marine Corps' focus of fielding state of the art technology that is necessary for achieving their logistics visions.

The Office of Naval Research provided the funding for this effort. The organizations involved in the planning, execution and documentation of this work are listed below. Specific personnel involved in the work are identified the table in Appendix B3.

Third Force Service Support Group
Marine Forces Pacific Experimentation Center
Headquarters Marine Corps
Naval Facilities Engineering Service Center
Army Logistics Integration Agency
Science Applications International Corporation
Center for Naval Analysis
Unisys
NAL Research Corporation

In an effort to ensure the continued research, development and testing of technology suitable for providing Total Asset Visibility in Marine Corps operations, a focus team has been established. The formation of the Total Asset Visibility Focus Team precipitated from the worked performed in preparation of this experiment and the past efforts that have focused on providing a Total Asset Visibility capability to the Marine Corps. The first task to be completed by the team is the development of a Universal Needs Statement addressing technology required for providing Total Asset Visibility. Information about this team may be obtained by contacting the following activities:

Third Force Service Support Group
CWO2 Paul Major
DSN: DSN 637-1679
Email: majorpe2@3fssg.usmc.mil

Marine Forces Pacific Experimentation Center
Mr. Shujie Chang, Director
DSN: DSN 88-315-477-8577
Commercial: (808) 477-8577
Email: changs@mfp.usmc.mil

Headquarters Marine Corps
Installations and Logistics (LPV)
Mr. Nick Linkowitz
DSN: 225-6101, x1139
Commercial: (703) 695-6101, x1139
Email: linkowitznm@hqmc.usmc.mil

Naval Facilities Engineering Service Center
Mr. Dan McCambridge
DSN: 551-1296
Commercial: (805)-982-1296
Email: mccambridgedj@nfesc.navy.mil

1. Introduction

This document provides a description of experimentation of technology that can bring the Marine Corps closer to the goal of achieving Total Asset Visibility (TAV). The venue used for this effort was the Freedom Banner / Cobra Gold (FB/CG) 2002 exercise. This exercise was conducted in Thailand during April and May. The experiment was performed at the request of MAJ GEN Willie Williams, Commanding Officer, Third Force Service Support Group.

The purpose of this work was not to prove the feasibility of using technology for providing TAV capability to the Marine Corps. That point has already been proven and accepted. This effort focused on furthering the familiarization of this technology for the Marine Corps and gathering data and information about the use of this technology in operational environments. This data and information can support current Marine Corps initiatives to bring sensors to the battlefield. One such initiative is the Autonomic Logistics Universal Needs Statement¹.

To facilitate the reading of this document, the main body of the document has been kept short and directed at what was learned from the experiment. Detailed information is contained in the appendices and referred to as necessary in the appropriate sections. The document is organized as follows:

Sections 1.0 through 3.0 - These sections provide general discussion. The questions what, why and how are answered here. What did we do, how did we do it and why did we do it.

Section 4.0 - Concept of Operations

Section 5.0 - The data collection, reduction and analysis are provided in this section. From this work, the conclusions were derived and recommendations followed.

Section 6.0 - Conclusions

Section 7.0 - Recommendations

Section 8.0 - Appendices

Appendix A: CNA, Unisys and SAIC After Action Reports - These independent assessments are presented in this appendix. Representatives from these organizations were involved in the experiment. The assessments are used in addition to the analysis performed on the data in this report to arrive at the conclusions and recommendations that are presented in Section 7.0.

¹ [Autonomic Logistics Universal Needs Statement](#); HQMC, I&L

Appendix B: Test Plan Documentation - This appendix contains Test Plan information. Appendix B provides the majority of the architectural and operational information on the technology that was used during the experiment. The administrative and safety information is also provided here.

Appendix C: Data Collection - This appendix contains the blank data sheets that were used for collecting data during the exercise and the procedure used to collect that data.

Appendix D: Raw and Reduced Data - Samples of the completed data sheets are provided in this appendix. The reduced data is also provided here.

Appendix E - Acronyms

2. Objectives

This experiment had three objectives:

- 1) Provide the Third Force Service Support Group with technology that can enhance the TAV of equipment.
- 2) Identify and measure bandwidth parameters of the technology used to provide the TAV. This data will be used to compare this technology with the bar code scanning systems currently fielded in the Marine Corps. This data can also be used to evaluate sensor technologies that will be deployed in the battlefield.
- 3) Evaluate the capability to provide near real time visibility of deployed assets through existing or joint operational internet based systems.

In order to measure the degree to which these objectives were achieved, the following metrics were established:

- 1) Reduce the number of personnel required for performing equipment-tracking functions during an MPF operation by 25%.
- 2) Reduce the time required to determine location of specific Principle End Items by at least 90%.
- 3) Reduce the number of personnel required to determine the location of specific Principle End Items by at least 50%.
- 4) Provide visibility of items in near real time – less than 15 minutes.
- 5) Reduce the time required to reconcile MDSS II data files at MPF transportation nodes (POG, MCC, AAOE...) by 50%.

Four component technologies were utilized to achieve these objectives and gather data to assess the metrics. The first was an RFID system that captured the identification of Principle End Items (PEI) at specific locations during the offload process. The second consisted of two information system tools, the Asset Viewer Manager (AVM) and the Army's In-Transit-Visibility (ITV) system. These tools displayed the data captured by the RFID system in a manner useful to personnel that needed near real time asset visibility of the PEI. The third component was an Iridium satellite link. This link will provide a global TAV of the offload process. The final component was the technology that was used to monitor the data traffic over the communications networks established by the Marine Corps for the exercise. A more detailed description of these four components is provided in Appendix B.

3. Background

3.1 Requirement

TAV is a critical capability required by the Marine Corps. This requirement is reflected implicitly and explicitly all throughout Marine Corps literature and activities. The Commandant of the Marine Corps has defined TAV as follows:

Total Asset Visibility (TAV)- The capability to provide users with the timely and accurate information on the locations, movement, status, and identity of units, personnel, equipment, material, and supplies. It also includes the capability to act upon that information to improve the overall performance of the Department of Defense logistics practices.

The current vision of logistics further addresses the need for this capability. The elements below address some specific areas of this vision²:

Guiding Principles

....

We will organize logistics capabilities to ensure the commander in the field can be absolutely confident that required support will be provided when and where it is needed.

....

1.3 Improve Distribution.

1.3.1 ...develop and field Automatic Identification Technology (AIT) capabilities to support the identification and processing of materiel within the storage and distribution processes.

1.3.4 Achieve 100% automated visibility, access and redistribution of all classes of supply...

² Marine Corps Logistics Campaign Plan 2002

- 1.4 Develop Logistics Command and Control Capabilities.
 - 1.4.2 ...conduct research and development of the Autonomic Logistics concept in conjunction with the Office of Naval Research.

3.2 Challenge

The Marine Corps has used AIT for many years as a means enabling this vision. The current AIT capability used during MPF operations consists of using linear barcode scanners. This technology is very useful in some areas. It is outdated in others. Two of the areas in which current AIT can improve on barcode scanning is addressed above in the Commandant's statement: **TIMELY AND ACCURATE INFORMATION**. The barcode capability used today does not serve these two areas well. TAV of equipment during MPF operations is currently latent and requires redundancies to ensure accuracy. The current process is also not automated to a large degree. This tends to suppress the flow of equipment from the ship to the Major Subordinate Command. Pier-side offload of equipment can take on the order of hours using the barcode system compared to minutes using more advanced AIT³.

4. Concept of Operations

The Concept of Operations (CONOPS) that was developed for this experiment is presented in Appendix B, Test Plan Documentation. The CONOPS was developed as part of the Test Plan prior to the start of the experiment. There were differences between the planned and 'as-tested' configurations. The differences are identified and explained in the appendix.

Also included in Appendix B is information on the set up and operation of the equipment, specifications of the equipment and administrative information related to the experiment. Appendix B serves to provide the majority of the architectural and operational information on the technology that was used during the experiment.

5. Data Collection, Reduction and Analysis

The data collected during the experiment was reduced and analyzed to draw conclusions on how the use of AIT can enhance Marine Corps processes. This analysis will also provide information that may be used to assess the impact of battlefield sensor technology on Marine Corps processes and equipment. The processed used to collect, reduce and analyze the data is contained in this section.

5.1 Data Collection

The process used for data collection is described in Appendix C. Two processes were used to collect the data. One process was that of objective observation. The other was by computer data acquisition. The observation process was used to

³ Technical Memorandum TM-2315-AMP: NAVAL ASSET VISIBILITY LIMITED TEST ASSESSMENT DURING PACIFIC IMPACT EXERCISE IN SUPPORT OF COMBAT SUPPORT GROUP III; Robert Paguio, Daniel McCambridge; May 1999

investigate all of the human-driven processes used by the Marine Corps during the offload. The computerized process was used to investigate the network parameters. The data collected by the CNA and Unisys representatives is not provided in this document.

The raw data that was collected is provided in Appendix D. Three sets of raw data were collected. The first set was the data captured on the sheets that were used during the installation of RFID tags on the PEI aboard the MV Williams. These data sheets document the specific tags that were installed on specific PEI. This data was used to associate that tags to the PEI in the AVM. The data was transferred from the original data sheets into electronic format. The electronic format is presented in Appendix D1. The second set of data is that capturing the human-driven processes. Selections of this data are presented in Appendix D2. Also included in Appendix D2 are copies of some of the data sheets filled out on the MV Williams to identify the PEI tagging process. The third set is the data captured by the network monitoring software that was run during the experiment. This data is presented in Appendix D3.

5.2 Reduction & Analysis

The data reduction and analysis effort was focused on being able to draw from the data that was collected, information that could be used to assess the metrics that are identified in Section 2. Three areas were addressed to satisfy this effort. The first was a comparative analysis of the current Marine Corps process used to offload the ships and the RFID capability. The second was a discussion on the two information systems used to present the RFID data, the AVM and Army ITV. The third was the network analysis. This reduction and analysis was the basis for the conclusions and recommendations presented in Sections 6 and 7.

The three reduction and analysis areas are discussed below. In each area, applicable metrics are identified. A discussion follows, first describing the process of the data reduction and analysis and ending with a finding that assesses the metric. Additional discussion outside that pertaining to the metrics is also provided when appropriate.

5.2.1 Marine Corps Offload Process vs. RFID Technology

1) Reduce the number of personnel required for performing equipment-tracking functions during an MPF operation by 25%.

Marine Corps Process

The Marine Corps equipment-tracking process used during MPF offloads consumes a significant number of personnel. Personnel are required to collect and reconcile data, produce reports, reconcile discrepancies, locate misplaced equipment and many other functions. The CNA report in Appendix A1 found that fully 63% of the billets required to staff the organizations supporting the offload are dedicated to equipment tracking.

By analyzing the different organizations conservatively, the number of personnel required to support only the scanning and data manipulation can be determined. There were ten points at which PEI were scanned during the operation. These are listed below:

POG In	NSE AAOE In
POG Out	CE AAOE In
MCC In	GCE AAOE In
MCC Out	ACE AAOE In
Disassociation Lot	CSSE AAOE In

Each of these locations required at least two personnel to conduct scanning operations. Seven of these locations were equipped with MDSS II functionality for reconciling and transmitting data. This task required at least one person per location. The locations of the LFSP and AAOG each required MDSS II functionality. This required two more people.

The conservative total number of personnel involved with these functions was 29.

RFID Technology

The RFID reader sites would be set up at each of the scanning points if this technology were to replace the scanning operations. These sites require personnel for set up but no personnel during operation. Assume that three 2-person teams are required for set up and monitoring each reader site. One team would monitor the POG and MCC. The other two teams would be responsible for the five AAOEs. Each computer operating the RFID readers would require one person to ensure consistent operation. The locations that would require computers during a fully RFID -equipped operation are the POG, MCC and each AAOE. This assumes that the Disassociation Lot (and/or Frustrated Equipment Area) would be within wireless connection range of the POG or MCC. This set up would require 7 personnel. One additional person would be required to operate the web server to which the RFID data would be posted.

The total number of personnel involved with these functions would be 14.

Finding

The number of personnel required to conduct equipment-tracking operations would be 14, reducing the requirement by 15 people or 52%.

5.2.2 Information Systems: AVM and Army ITV

The discussion in this section focuses on two areas. The first addresses the remaining metrics. The information systems (IS) that were used provided the type of TAV capability for which the Marine Corps is searching. Each of the metrics discussed

relate directly to capabilities that are realized through the information brought forth through TAV technology.

The second area of discussion pertains to the two IS used, the Asset Viewer Manager and the Army ITV. Each system provides different similar and differing aspects. These aspects are discussed.

Metrics

2) Reduce the time required to determine location of specific Principle End Items by at least 90%.

During the observation of the offload, many instances were observed involving personnel from the AAOG or LFSP attempting to locate specific PEI. One such instance involved personnel at the LFSP receiving requests to provide the location of a PEI. The request was provided by radio. At the time the request arrived at the LFSP, non-Marine Corps personnel checked an IS for the serial number of the PEI in question. The item was immediately visible on an IS. The PEI had arrived at the MCC. The LFSP determined the location of the PEI approximately 20 minutes later.

Finding

If one minute is used as the time required for the user to locate the PEI with the IS, the time required for the Marines to locate a specific PEI was reduced by 19 minutes, or 95%.

3) Reduce the number of personnel required to determine the location of specific Principle End Items by at least 50%.

In the above example, there were at least 3 people involved in the search for the PEI. These were the person at the LFSP handling the request, one person at the POG-In scan point and one person at the MCC-In scan point. Using the RFID system and the AVM, there was one person required.

Finding

The number of personnel required to locate a specific PEI was reduced from 3 to 1, or 66%. Note that this number is likely conservative. It is unknown if any, but probable that, Marines were dispatched at the POG and MCC to locate the PEI.

4) Provide visibility of items in near real time – less than 15 minutes.

The time required for visibility of items posted to the AVM was on the order of minutes. The time delay was predominantly a function of the hardware and software settings on the systems used.

The time required for visibility of items posted to the Army ITV was approximately minutes. Again, the time delay was predominantly a function of the hardware and software settings on the systems used. The reason for the ITV posting having a greater delay than the AVM is due to the Army servers used for that system. There is a 15-minute delay designed into those servers. Had that delay not been created, the visibility would have been on the order of minutes.

Finding

Visibility of PEI on the IS was less than 2 minutes, except as noted above.

5) Reduce the time required to reconcile MDSS II data files at MPF transportation nodes (POG, MCC, AAOE...) by 50%.

Data was not collected to directly assess this metric. As discussed in Appendix B2, the AVM interface to MDSS II was not operational during the experiment. As such, the only method used to reconcile the MDSS II data collected at each of the scan points was the current Marine Corps system. This method is discussed the CNA After Action report (see Appendix A1, p. 8-9).

Past experience and observations made during this experiment provide overwhelming evidence that the current system for reconciling data and subsequently transferring custody of PEI is at least cumbersome. Three items are the cause of this situation: insufficient data, data inaccuracy and system complexity. Data insufficiency is the result of incomplete Equipment Density Lists and missing data in the MDSS II data files. Data inaccuracy is the result of errors in the MDSS II database and data input errors occurring during operations. The latter errors occur when the barcodes cannot be scanned and the data is input manually and when users must manually populate vacant data fields. System complexity is the cause of many errors that are experienced by users when trying to reconcile equipment files. This complexity translates to time when users attempt to correct the errors. The amount of time required to correct the errors is a function of the user's knowledge and experience about MDSS II and the number of errors that exist.

Finding

The reduction of time required for MDSS II data reconciliation was unresolved. Experience indicates that the reconciliation process is a source of significant delays in moving equipment to the Major Subordinate Commands.

AVM and Army ITV Systems

The AVM and Army ITV systems used during this experiment provided the Marine Corps the ability to see how TAV can be used in the process of an MPF offload. These are the systems that provided information developed directly from battlefield sensors supplying data. In this case, the data fields were equipment identification and location. Both systems were similar in some ways and different in others. This section discusses those similarities and differences.

The AVM is a test and evaluation system developed to interface with RFID systems, operate on data to create information and provide that information to the user in some useful format. The purpose of it is to demonstrate the capabilities that can be realized through TAV technology. The level of detail available to the user can be the same as that provided in the Equipment Density List produced from MDSS II. The Army ITV system can provide the same functionality. Screen shots of both systems are provided in Appendix D4. Both systems provide views into, essentially, the same data.

The differences in these systems open a useful discussion into what will best serve the Marine Corps. These differences are provided below with discussion on how they affect capability. Some questions are generated based on the discussion. These and many others must be answered in order for the Marine Corps to be provided the type of technology that will best serve them.

Gate Reader vs. Vicinity Reader

The AVM collects data from both types of readers. The Army ITV collects only from vicinity readers. Gate readers provide event-driven location data. The gate reader will report immediately when a tag passes it. The vicinity reader will provide a snap shot in time about what tags are within its read range at that time. Gate readers are much more complex units.

Question – Is event-driven (near-real-time) asset visibility a requirement?

Data Source

The AVM collects only the tag manufacturer's hard coded identification number. A database association is then conducted to access information on the PEI. The Army ITV system takes advantage of the tag's write capability. PEI data is written to the tag and then collected by the reader.

Question – Should more than just the tag identification number be collected during use?

ITV vs. TAV

TAV capability is generally accepted as being a subset of ITV. ITV is associated with large-scale movements. TAV can be much more detailed. An example of having the manifest of a container electronically is a TAV capability. Knowing where the container is or on what ship or vehicle it is loaded is an ITV capability.

Question – When and where is TAV needed and when and where is ITV needed?

Visibility vs. Management

The ITV and AVM both provide TAV of the tagged equipment. The AVM allows the user to sort data via the web browser using various queries. This capability can provide management of the offload process by commanders.

Question – Is management functionality a requirement for an MPF offload tool?

The overarching question to be answered is ‘Who needs what information and when do they need it?’. Once there is a comprehensive answer, the Marine Corps should be able to procure one tag and only one tag (i.e. G-Tag specification compatible) that meets all needs.

(Note to the reader – The Army ITV is a fully mature, fielded system used by the Army today. The AVM is developmental. It should not be concluded that the AVM is ready for use in the field.)

5.2.3 Network Analysis

The software used to monitor the network is called Etherpeek. A description of this software is included in Section 5 of Appendix B2. A data collection template was created with the software and used on three computers. Two of these computers were the RFID software and the other computer was running the AVM.

The templates were designed to capture the first 128 bytes of data from each data packet transmitted on the network. This 128-byte capture contained all the header information for the data packet. Contained in this header were all of the parameters of the data packet that were necessary to perform the analysis. This data was logged to a file. Once the file reached approximately 4 megabytes, the file was saved and a new one started.

Appendix D3 contains graphical representations of selected data that was collected and the reduction of that data. These selections represent two sets of data. Each set consists of one data collection period on two different days. The data sets are represented in three variations. The first represents all of the data transmitted over the network as seen from the RFID computer connected to the network at the LFSP. The

second represents only the RFID traffic riding on the network. The third compares the first two variations.

As can be seen in the graphs for the third variation (Appendix D3, pages 4 and 7), the impact on the network budget from the RFID traffic was minimal. One must keep in mind, however, that there were only 133-136 tags used during this experiment. In addition, only the tag identification field (and the tag overhead data) was transmitted. During a larger offload, the impact of the RFID data transmissions on a network would be more significant. If two MPF ships were fully offloaded, more than 4000 tags might be used. The network impact would not be a linear progression, but interesting to investigate. System variables such as file size and transmission frequency could be varied to determine the impact on network efficiency.

Network efficiency is a key consideration in any network administrator's mind. The RFID data transmission efficiency was not a consideration during this experiment. Insight to the impact of its effect on efficiency can be seen in the graphs on pages 3 and 6 of Appendix D3. The most inefficient use of a network is the transmission of many small packets. These graphs show that the majority of the data packets transmitted were of a small size. File transmission efficiency is an important consideration when looking to increase the quantity of data flowing over organic Marine Corps communications equipment. It will be no less a consideration in their next generation (read Iridium...) of equipment.

Finding

RFID data transmission had little impact on the Marine Corps network budget. Further investigation is warranted to assess the impact in a larger exercise.

6. Conclusions

The conclusions provided here are done so as a compendium based on the organizations involved with the work. Basic metrics were established as guides on the path toward achieving the goals. While traveling the path, several other interesting items came forward. Findings and conclusions are provided throughout the document including the after action reports provided in Appendix A. The metric assessments are provided first with summaries of additional findings and conclusions following.

Metric Assessments

- 1) Reduce the number of personnel required for performing equipment-tracking functions during an MPF operation by 25%.

Personnel Reduction = 52%

- 2) Reduce the time required to determine location of specific Principle End Items by at least 90%.

Time Reduction = 95%

- 3) Reduce the number of personnel required to determine the location of specific Principle End Items by at least 50%.

Personnel Reduction = 66%

- 4) Provide visibility of items in near real time – less than 15 minutes.

NRT Visibility < 2 minutes

- 5) Reduce the time required to reconcile MDSS II data files at MPF transportation nodes (POG, MCC, AAOE...) by 50%.

Unresolved

Additional Findings and Conclusions

The findings and conclusions listed here are categorized by either a technical or operational nature.

Technical

1. RFID data transmitted in this experiment had minimal impact on the Marine Corps organic network that was established to support the MPF offload.

2. The lack of the ability to automate the data collection, distribution and reconciliation increases the errors encountered by personnel responsible for tracking equipment during the offload process.
3. The Iridium satellite technology can provide an order of magnitude increase in the communication capability of the Marine Corps. This technology will be necessary to achieve true boundless TAV.

Operational

1. The function of tracking equipment during an MPF offload requires a significant number of personnel and equipment. Commercial technology exists that can reduce this requirement.
2. Use of automated tracking technology would reduce the time required to move equipment from the entrance of the Port Operations Group to the Major Subordinate Command.
3. Many questions exist that must be answered prior to the Marine Corps being able to procure a system that will adequately satisfy their TAV requirements.

The goals of this experiment were achieved. A TAV capability was provided to the 3D FSSG. That unit is currently installing RFID sites in Okinawa and utilizing the Army ITV server to provide visibility. The impact of RFID data on Marine Corps networks was assessed. The apparent impact is minimal. The use of TAV technology was evaluated during an MPF offload exercise. The efforts put forth by the personnel involved in this experiment have furthered the cause of bring technology to the fleet. The next section addresses some of the additional work that must be performed to make sure that this technology adds value to the Warfighters.

7. Recommendations

Based on the conclusions provided in Section 6, there are several recommendations provided here that are deemed necessary to bring TAV technology to the fleet.

1. Develop a Universal Needs Statement applicable to the utilization of Total Asset Visibility technology in the Marine Corps.
2. Investigate, on a large scale, the application of TAV technology in a Marine Corps operation.
3. Investigate separate and independent RFID systems that are capable of reading a tag manufactured to the G-Tag specification when it becomes available.

4. Develop a concept of operations for applying TAV technology in all Marine Corps processes. The goal of this task would be to identify the common data and information requirements that would be satisfied in the design of a TAV technology. This work would be instrumental in achieving a 'one-tag-fits-all' solution.
5. Thoroughly investigate other services' TAV initiatives to leverage technology wherever possible.
6. Continue using the Iridium satellite technology to enable and enhance Marine Corps logistics processes.

8. Appendixes

Appendix A

CNA, UNISYS and SAIC After Action Reports

Appendix A1: CNA After Action Report

Appendix A2: Unisys After Action Report

Appendix A3: SAIC Iridium Report

Appendix A1

CNA After Action Report

Total Asset Visibility Demonstration

Freedom Banner O2

Limited Assessment

June 2002

Jonathan Geithner
MARFORPAC CNA Representative
Geithnerjd@mfp.usmc.mil
808-477-8578

SUMMARY	3
APPROACH.....	3
FINDINGS.....	3
CONCLUSIONS.....	4
INTRODUCTION	5
BACKGROUND.....	5
APPROACH.....	5
SCOPE AND LIMITATIONS.....	6
OVERVIEW OF FREEDOM BANNER 02	7
COMMAND RELATIONS.....	7
THE OFFLOAD FLOW.....	8
TRACKING THE OFFLOAD.....	8
TRANSFERRING ACCOUNTABILITY FOR EQUIPMENT.....	9
PERSONNEL/EQUIPMENT NEEDED TO TRACK THE OFFLOAD.....	10
COLLECTING AND PROCESSING SCAN DATA.....	11
OFFLOAD STATUS REPORTS.....	12
ACCURACY AND TIMELINESS OF THE REPORTS.....	13
<i>Timeliness of reporting</i>	13
<i>Report accuracy</i>	14
<i>Other tracking challenges</i>	16
<i>Were information delays/errors a problem?</i>	16
RFID TECHNOLOGY DEMONSTRATION (FB 02)	17
RFID BASICS.....	17
THE RFID DEMONSTRATION.....	17
<i>Collecting and processing the tag data</i>	18
<i>Displaying the data</i>	18
<i>RFID data issues</i>	20
CONCLUSIONS	21
APPENDIX A: OFFLOAD TRACKING PERSONNEL	22

Summary

The MARFORPAC Experimentation Cell (MEC) requested that CNA help assess the potential of radio frequency identification (RFID) technology for improving the visibility of equipment during MPF offloads. The Marine Corps currently uses bar codes and scanners to track the movement of equipment as it comes off the ships. This is time-consuming, manpower intensive, and often inaccurate. Our assessment is limited to data and observations collected during the demonstration of two RFID systems in *Freedom Banner (FB) 02*, a partial two-ship offload conducted in support of Exercise *Cobra Gold 02*.

Approach

We reviewed the methods and systems used by Marines to monitor the equipment flow. We focus on the different agencies involved, the personnel and systems required, how the data were collected and processed, and the timeliness and accuracy of status reports

Two RFID systems were run in parallel with the bar code scanning process on a subset of the equipment offloaded. This enabled us to identify potential advantages offered by RFID in satisfying the information needs of the commander and the arrival and assembly organizations.

Findings

Tracking the offload during FB 02 with bar code scanners required a lot of people and equipment. We estimated that upwards of 63 percent of personnel in the arrival and assembly organizations were involved in some aspect of the tracking process. This excludes Navy personnel and Marines on the ships preparing the gear to be offloaded. There also were multiple collection sites, each requiring a separate set of scanners and laptops.

Collecting and processing the data took an inordinate amount of time. Scan updates were required every two-hours. This data had to be manually processed, scrubbed, and fashioned into reports. Sometimes this required face-to-face meetings between personnel from different arrival and assembly organizations, and/or between the Navy and Marine Corps. Other times the scan data had to be verified against physical inventories.

Using the data to create reports took even more time. We estimated that it took on average 12 hours between the time an item was scanned in at the port and when the data made it into one of the offload status reports. And these reports were not always accurate. One showed equipment as being offloaded one or more days *before or after* it actually had been. Also, no two reports agreed on the total number of items to be offloaded. This resulted in an over- or understatement of the progress of the offload to higher headquarters.

To our knowledge these shortcomings had little affect on the conduct of the offload. But they cast doubt on the system's potential for handling a much larger pier-side evolution running 24 hours a day in conjunction with beach and air operations. This

scenario would require far more personnel and scanners to cover day and night shifts and the additional locations. Even with the added personnel we suspect there would be major challenges in keeping up, particularly if the offload sequence and/or distribution of equipment were to change.

In contrast to the bar code scanning process, RFID systems are almost completely automated, require far fewer people to operate, and provide offload data in near real time. While neither system produced a complete set of data, problems encountered either were resolved during the test or are thought to be easily correctable.

Conclusions

A more comprehensive assessment of sensor technology would be based on answers to questions the demonstration could not provide, such as cost and ownership of the system, training, security, bandwidth requirements, and durability, among others.

These issues aside, RFID technology would appear to offer significant advantages over the existing Marine Corps offload management system. Automating the data collection process would eliminate the need for scanning personnel and those responsible for processing the offload data.

Improving the accuracy of the data will reduce uncertainty over what's been offloaded and where it is in the distribution process. This will eliminate the need for lengthy reconciliation efforts.

Having access to the data in near real time will provide greater control over equipment, making it easier to reallocate gear if the commander's priorities change. Allowing this data to be viewed by the commander and his staff could eliminate the need for status reports to higher headquarters.

Introduction

Keeping track of assets and personnel while in transit has long been a challenge for all the military services. One famous lesson from the Gulf War was the need to open over 20,000 containers to see what was inside them.¹ The lack of good visibility can lengthen the time it takes to generate a combat ready force.

This paper reconstructs select aspects of the Maritime Preposition Force (MPF) offload conducted during *Freedom Banner (FB) 02* in Thailand from 3-10 May 2002. The main focus is on the processes and systems used to track and account for equipment as it was offloaded and distributed. Currently the Marine Corps uses bar code labels and scanners to manage offloads. This is time-consuming, manpower intensive, and often inaccurate. Radio frequency identification (RFID) technology demonstrated during FB 02 may reduce the burden on Marines for tracking gear and improve the timeliness and accuracy of offload data. The purpose of this paper is to examine how RFID technology might offer improvements over bar codes and scanners in managing force closure operations.

Background

The demonstration of RFID technology during FB 02 is the latest in a long line of initiatives within the Marine Corps and throughout DOD for improving the visibility of equipment and personnel as they are moved from one location to another. The Marine Corps' stated goal is *Total Asset Visibility* (TAV), defined as the ability to provide users with timely and accurate information on the location, movement, status, and identity of units, personnel, equipment, material, and supplies so as to improve the overall performance of logistics practices.² TAV is broadly thought to enhance warfighting capability and reduce operating costs.

Based on these objectives, the Marine Forces Pacific (MARFORPAC) Experimentation Center (MEC) in conjunction with the Third Force Service Support Group (3d FSSG) and Naval Facilities Engineering Service Center (NFESC) began a series of initiatives aimed at using sensor technology to achieve TAV. That dialogue resulted in various demonstrations of RFID technology during exercises over the last couple of years and ultimately in the deployment of an RFID system for FB 02.

Of all the services, the Army has made the greatest progress in applying sensor technology to achieve total asset visibility. To learn more about the Army system, 3d FSSG personnel arranged for a UNISYS representative to deploy a similar RFID system for FB 02. The combination of the two RFID systems it was hoped would provide insight into the potential of RFID in helping the Marine Corps achieve TAV.

Approach

We first outline the existing systems and processes used by Marines during FB 02 to monitor the flow of equipment from offload points on the pier through the port area

¹ James Miller, *Intransit Visibility: Capturing All of the Source Data*, graduate research paper, School of Logistics and Acquisition Management, Air Education and Training Command, May 1996.

² United States Marine Corps, *Logistics Campaign Plan*, 2002.

and ultimately to the arrival and assembly operations elements (AAOE). We discuss the different agencies involved, the personnel and systems required, how data is collected and processed, and the timeliness and accuracy of the status reports.

Two RFID systems were run in parallel with the bar code scanning process on a subset of the equipment offloaded. This enabled us to identify potential advantages offered by RFID in satisfying the information needs of the commander and the arrival and assembly organizations.

Scope and limitations

This is a quicklook report that relies exclusively on observations and data from a single offload. FB 02 involved the in-stream partial offload of roughly 500 principal end items (PEIs) from two MPF ships. The offload was conducted during daylight hours over an over an eight-day period. As such, the pace and scale of the offload is probably not a good proxy for the simultaneous pierside offload of one or more MPF squadrons and thousands of PEIs that might be expected to occur in a contingency.

The layout of the port and the proximity of the AAOEs to the port may have made it easier to keep track of the offload than might be the case at another facility. For example, the Movement Control Center (MCC) was only a couple of hundred yards from the pier. And the AAOEs were only a twenty-minute drive from the port. Increasing the distance between these locations would complicate tracking efforts. Flowing equipment simultaneously over the beach also would have added complexity.

The vast majority of exercise equipment was brought by sea. In a real contingency the arrival and assembly organizations would also have to manage the arrival of equipment by air. This too would add complexity to the tracking process.

Ideally, we would have liked to compare a mature RFID system with the bar-code scanning equipment currently in use. This would have given us truer indicators of the virtues and challenges associated with each. Instead, we focus on the *potential* vice the current suitability of either of the RFID systems demonstrated.

Our assessment of this potential is based solely on its contribution to enhancing in-transit visibility. Having greater visibility presumably could improve many other aspects of Marine operations such as supply support and follow-on sustainment. Sensor technology also could be used to relay data on the condition of an individual piece of equipment. We do not address these broader applications, but they likely will figure in decisions to pursue sensor technology.

Overview of Freedom Banner 02

Freedom Banner is the MPF component to exercise *Cobra Gold*, a combined, joint exercise between military forces from the U.S. and Kingdom of Thailand. The offload was conducted in-stream during daylight hours from 3-10 May with the *MV Lumus* and *MV Williams* at anchor roughly 3 miles from port and the *SS Gopher State* pierside.

Command relations

Various arrival and assembly organizations were established to conduct and manage the offload. CG 3d MEB assigned a portion of the MEB and major subordinate command staffs as the Arrival and Assembly Operations Group (AAOG). The AAOG's main function was to coordinate and control arrival and assembly operations.

Under the operational control of the AAOG were the Arrival and Assembly Operations Elements (AAOEs). These were established for each major subordinate element (MSE) of the MAGTF as well as the Naval Support Element (NSE). AAOEs received and distributed gear at the unit assembly areas.

Also under the control of the AAOG was the Landing Force Support Party (LFSP). The LFSP controlled the throughput of and distribution of equipment from the port to the AAOEs through two subordinate organizations: the Port Operations Group (POG) and Movement Control Center (MCC). The POG was responsible for preparing the port prior to the arrival of the MPF ships and for the subsequent throughput of equipment as it was offloaded. The MCC formed vehicles into separate MSC convoys for movement to the AAOEs.

Commander, Amphibious Group (PHIBRU) Three was designated as Commander, MPF (CMPF). Under the operational control of the CMPF were MPF Squadron (MPSRON) Three, the Naval Support Element (NSE), and the Naval Coastal Warfare (NCW) element. The MPSRON consisted of the MPS ships and personnel. The NSE handled the offload and the ship-to-shore movement. Figure 1 lays out these relationships.³

Figure 1. FB 02 command relations

³ Figures 1 and 2 were supplied by the CNA representative to III MEF.

information on each piece of equipment on every MPF ship. It is used to build unit density lists (UDLs) and source MAGTF requirements prior to deployment, and to track equipment throughout the deployment and backload.

There are two primary steps to using MDSS II to track offloads. The first is to construct a master file of items to be offloaded and distributed. This was given to each arrival and assembly organization before the offload began. The second step is to scan bar code labels on each piece of equipment, upload this data into MDSS II, and associate the data with the offload file. Bar code labels contain detailed data on each PEI to include unique serial numbers, a description of the item, and dimensional data, among other information.

Equipment was scanned as it entered and exited the OPP and MCC, and upon arrival at the AAOEs. Mobile loaded equipment was recorded as entering the dissociated cargo lot upon leaving the POG and prior to entering the MCC (see figure 1). Because each scanner was associated with an arrival and assembly organization, and because each arrival and assembly organization was associated with a geographic location, the AAOG could use the data to track the location of equipment.

Scan data was uploaded every two hours and sent by the LFSP and AAOEs to the AAOG. The AAOG, in turn, used the data to develop various recurring offload status reports. Each scan update overwrote the previous MDSS II file, providing a snapshot vice a moving picture of the offload.

Personnel at each scan site also were directed to maintain logbooks detailing the item ID, serial number, description, and date/time the equipment passed through their area. This was done by some, but normally at a more general level of detail.

Transferring accountability for equipment

MDSS II also served as the primary means for transferring custody of equipment. This was necessary to ensure that items were distributed to the correct location/unit and to facilitate regeneration.

The transfer of accountability of equipment from the Marine Corps Maintenance Officer (MCMO) to the Marine Offload Liaison Officer (MOLO) occurred as equipment was offloaded from the MPF ships. MDSS II scan files served as the interim receipt reflecting items transferred from ship to shore. These were reconciled by the MCMO and MOLO at the end of each day. Transfer of accountability from the MOLO to the BSSG (in the custody of the POG) occurred simultaneously with MCMO-to-MOLO transfer.

Accountability shifted from the BSSG to the unit AAOEs as equipment arrived at the AAOE, again using MDSS II scan data. Equipment was then distributed to each unit where it underwent a limited technical inspection (LTI). Based on the outcome of the LTI, each AAOE completed a consolidated memorandum of receipt (CMR) assigning official custody of the gear to a responsible officer (RO) within the unit. This was to be done using ATLASS software, but most simply e-mailed excel spreadsheets to the AAOG.⁴

⁴ ATLASS stands for "Asset Tracking Logistics and Supply System."

Personnel/equipment needed to track the offload

The physical aspects of offloading and distributing equipment are labor-intensive, requiring hundreds of Marines and Navy personnel. Many of these personnel also are involved in tracking/accounting for equipment as it comes off the ships. These personnel include scanners, MDSS II operators, MSE liaison officers, operations officers, clerks, and others. We examined the tables of organizations (T/Os) of each arrival and assembly organization to determine what percentage of the total was required for these tasks. The results are shown in table 1. We excluded Navy, BIC, OPP, and A/DACG personnel. As such, our estimates represent a lower bound.

Table 1. FB 02 personnel involved in tracking/distribution/accountability of equipment

<i>Arrival and assembly organizations</i>	<i>Total personnel</i>	<i>Personnel involved in tracking/accountability</i>	<i>Percent of total</i>
AAOG	38	23	61%
LFSP HQ	11	11	100%
POG	49	39	80%
MCC	7	5	71%
AAOEs (x5)	35	10	29%
Total	140	88	63%

Of note is the large number of agencies and personnel involved in the tracking/accountability process. We identified a total of 88 Marines, or 63 percent of the personnel that made up the different arrival and assembly organizations.⁵ Appendix A provides a breakdown by billet within each organization.

There are also considerable equipment and software requirements, to include multiple scanning devices, interface/cradle chargers, batteries, laptops with MDSS II/ATLASS software, printers, tactical phones, cell phones, and radios. Each arrival and assembly organization was responsible for providing and operating its own suite of equipment. The figure below shows the different scan locations requiring this equipment.

Figure 3. FB 02 AIT locations

⁵ Numbers for POG may be overstated since some of the Marines serving at the scan sites were receiving training on the use of bar code scanners.

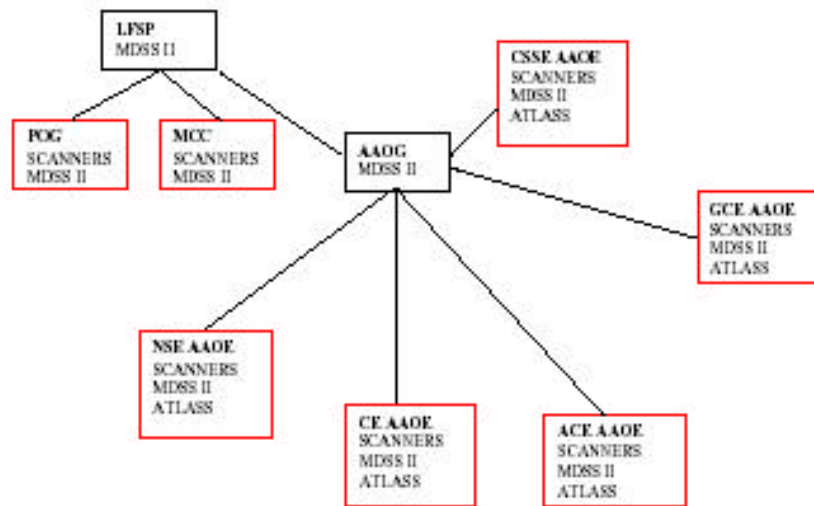

Collecting and processing scan data

Collecting and processing bar code scan data is a multi-step process. Once the laptops are set up and the scanners are charged, equipment passing through the site is scanned. This scan data is uploaded from the scanner to a floppy disk, imported into the MDSS II database, and processed for rejected records. The clean file is then sorted by location code and formed into a report for the AAOG that includes the item ID number, a brief description of the item, the location code of the scanner, and the item serial number. This report and a backup floppy disk must then be sent to the AAOG. For FB 02, this process was repeated five times a day.

The scanning itself can be difficult. For example, the bar code may be damaged or dirty. Glare from the sun can make it difficult to view the screen to verify that that scanner has successfully read the label. Some Marines wrapped the scanners in plastic to protect them from the rain. This also can interfere with a good scan. The combination of factors can cause delays and/or result in poor data.

Processing the data takes time. MDSS II creates error messages for data it can't reconcile. This may be because the NSN and/or serial number of the PEI don't match records in the database, or because the date/time stamp is wrong. These errors have to be manually corrected, sometimes by meeting face-to-face with other arrival and assembly personnel. This further delays the data flow. Below is a sample of LFSP scan data uploaded into MDSS II before it was scrubbed.

Figure 4. MDSS II Scan data excerpt

NSN	PKG ID	Serial Number	NSN Configuration	Item ID	Description
1080001081173	124841094		BARE ITEM	C4260	SUPPORT SYSTEM, SCREEN, CAMO
5820014318931	545745		BARE ITEM	A1957	
5820014318931	536048		BARE ITEM		
3830012789909	TRAM7298		BARE ITEM		
000000TRI/WALL	MLMULT10		BARE ITEM		
6115011504140	EZ08887	EZ08887	SKID MOUNTED	B0730	GENERATOR SET, 3 KW, 60 HZ SKID-MTD

6115011504140	EZ08829	61150111504146	SKID MOUNTED	B0730	GENERATOR SET, 3 KW, 60 HZ SKID-MTD
6896013333040	560736		NOT REDUCIBLE	A1955	RADIO TERMINAL SET

This is only a fraction of the problem records we found in the LFSP scan data. The NSN for one of the records appears to be a description of the item. Package ID numbers (2d column) are a mixture of data/time stamps, serial numbers, and item descriptions. Another record has what appears to be an NSN in the serial number column. Each of these discrepancies had to be corrected against the master offload file, increasing the time it took to build offload status reports.

Offload status reports

All of the arrival and assembly organizations maintained status boards and reports to track the offload. Table 3 lists the key reports, the information contained in each, the format in which they were developed, information sources, and the frequency with which they were updated.⁶ Many of these reports were printed out in poster-size form and hung throughout the HQs spaces. In other cases information was transferred to white boards for easy viewing.

Table 2. FB 02 offload status reports.

Agency/Report	Key offload info	Format/Medium	Data Sources	Updated
POG				
Offload Tracking Sheet	Vehicle type by MSC by ship	Excel	POG IN logs	Every 2 hrs
AAOG				
Offload/Throughput Forecaster	PEIs offloaded/to be offloaded by MSC by day by ship, current location/LTI status	Excel	MDSS II scan updates	Every 2 hrs
Offload/Throughput Status Report (O/TSR) (a.k.a. Transportation Closure Report)	Running total of PEIs received/LTIs complete by MSE as percentage of total/baseline	Excel	Master MDSSII Database, FAX from FMCC/AAOG	Daily (1800)
Master Location Tracker (Offload/Throughput)	Location of offloaded equipment	Excel	Master MDSSII Database/Excel location reports	Every 2 hrs
CMRs (AAOG consolidates)	PEIs in custody of units	ATLASS, MDSSII Report, or Excel	Master MDSSII Database ("LTI Complete" scan), reconciled w/final MOLO report/physical AAOE inventories	Daily (0800)
AAOG Sitrep	PEIs offload last 24 hrs by MSE (number LTI complete) /running total of all PEIs offloaded as percentage of total/Estimate of PEIs to be offloaded in next 24 hrs	E-mail (Word Doc)	O/TSR, etc.	Daily (1800)

The reports and the way in which they were created and updated offer some important insights into the tracking and accountability process. Most important is the *lack of automation*. For example, the POG's Offload Tracking Sheet was based on pen/paper

⁶ Excluded from this list are reports not related to the tracking or accountability of *equipment* such as morning reports, conference room schedules, Motor T. run rosters, etc.

logs kept by the Marines scanning vehicles on the pier. These logs were walked over to the POG trailer every two hours and keyed into an Excel spreadsheet. The information was then transcribed onto whiteboards.

AAOG reports also were created manually, first by importing the MDSS II scan data into Excel and then reformatting the data. This too had to be done every two hours. Excel was preferred to MDSS II in part because of the ability to create graphs. Occasionally this data had to be verified against physical inventories for accuracy. *The lack of automation delays the flow of information and increases the chances for errors.*

Also evident is that many of the reports were drawn from the same data source, primarily the consolidated scan reports generated every two hours in MDSS II. We would expect the data to agree, but they didn't in all cases. Reports were accessible on the shared drive and/or were posted to a local homepage.

Accuracy and timeliness of the reports

The offload status reports were the key means by which the AAOG kept track of the offload and provided updates to the MEB headquarters. Our analysis focuses on (1) the speed with which data was collected, reconciled, and reported, and (2) the accuracy of the reporting.

Timeliness of reporting

Several aspects of the tracking process created delays in recording the movement of equipment.

- **Update schedules had to be staggered.** The AAOG required the LFSP and AAOEs to submit scan data every two hours (at 0900, 1100, 1300, 1500, and 1700). To meet this deadline the POG and MCC were required to send their scan data to the LFSP one-half hour earlier (i.e., at 0830, 1030, 1230, etc). As such, data on a vehicle passing through the POG IN site at 0831 would not be sent by the LFSP to the AAOG until the 1100 update. This meant that scan data were as much as two-and-a-half hours old by the time they made it to the AAOG.⁷
- **The quality of the data was often poor.** Data uploaded by the LFSP and AAOEs had to be processed for rejected records, sorted into an interim report, and e-mailed to the AAOG. The AAOG then had to consolidate this data with scan data from the AAOE, adding additional time. The lower the quality of the data, the longer the scrubbing process.
- **Reports had to be created manually.** More time was lost building reports: (a) because data has to be exported into excel from MDSS II, and (b) because other data necessary for the report had to be added. For example, the scan data didn't contain the unit to whom the equipment was

⁷ Actual lags were not as great in some cases. For example the 0900 scan update at the LFSP was based on the last scan made by the POG IN at 0830. Similarly, the 1700 LFSP update to the AAOG was based on POG IN scans occurring up until 1630. What's important, however, is the average lag in data flow during twenty-four hour operations.

to be distributed. This was done by manually associating an item recorded by the bar code scanner with the appropriate MSE.

We calculated the average delay (or lag) between the time an item was scanned “POG IN” and when it first appeared on an AAOG offload status report. This helped us identify bottlenecks in the tracking process.

The Throughput Forecaster was the only AAOG report updated every two hours, corresponding to the scan upload schedule. The reports, however, were not available until some hours later as data were associated with MSEs and, when necessary, verified against physical inventories at the AAOEs.

The table below shows the time it took for data on a vehicle entering the POG at the start of the two-hour scan window to appear on the Throughput Forecaster. The last row is the average time delay (or lag) in hours. The column labeled “date/time available” indicates when the report was actually completed. This was based on the “last modified” date/time stamp on each file placed on the shared drive. The last column shows the cumulative lag.

Table 3. Time lags in data flow during FB 02

Max MDSS II scan lag	Throughput Forecaster Report		
	Lag (hrs)	Date/time of report	Date/time available
2:30	5/4/02 15:00	5/5/02 13:13	24:43:00
2:30	5/5/02 9:00	5/5/02 12:39	6:09:00
2:30	5/5/02 13:00	5/5/02 17:00	6:30:00
2:30	5/5/02 15:00	5/5/02 20:34	8:04:00
2:30	5/5/02 17:00	5/5/02 21:18	6:48:00
2:30	5/6/02 9:00	5/6/02 20:19	13:49:00
2:30	5/6/02 17:00	5/7/02 9:30	19:00:00
Average	2:30		12:09:00

The table shows a 12-hour average delay in the data flow. The delays on reports generated on 5 May were more reasonable, but even in these cases the information was three scan-updates old by the time the report was available.⁸

The Throughput Forecaster probably could have been updated more quickly. But it was a new report and it may have been more important to ensure its accuracy than to have it available quickly, at least during this test phase. Or it might not have been a priority given the workload and available personnel.

Report accuracy

We collected MDSS II scan data from the LFSP for every two-hour increment from 3-7 May and compared this data to summary reports generated by the AAOG. These summary reports were important since they formed the basis for daily updates to higher headquarters.

⁸ To be fair, the longest delays are associated with reports based on scan updates that occurred near or at the end of the workday (i.e., on 4 May at 1500 and on 6 May at 1700). Consequently, the delays reflect considerable dead time associated with non-working hours.

One of these reports, the *Throughput Forecaster*, was developed to give the MSEs a schedule of when they'd get their equipment. The report provided 17 pieces of information (updated every two hours) on all PEIs to be offloaded such as the serial number, item description, day offloaded/to be offloaded, current location, owning MSE, etc. We compared the "day-offloaded" field on the *Throughput Forecaster* updated on the morning of 7 May to scan data for the first four days of the offload. According to the *Throughput Forecaster* a total of 243 PEIs had arrived by this time. The results are shown below in Table 4.

Table 4. "Day-offloaded" discrepancies between the *Throughput Forecaster* and LFSP scan data.

	'Day-offloaded' discrepancies			
	- 1 day	- 2 days	- 3 days	+ 1 day
PEIs	28	2	2	2

We found discrepancies on 34 PEIs, or 14 percent of the total as of 7 May. In 28 cases the *Throughput Forecaster* showed a PEI arriving a day later than it actually had (column 1). Most of these errors (17) were associated with PEIs offloaded late in the afternoon on 3 May, the first day of the offload. Many of the remaining one-day errors were for PEIs offloaded in the afternoon of 5 May. We know of at least one instance in which LFSP personnel did not send their last scan update for the day to the AAOG until the following morning. This may help explain some of the one-day discrepancies.

In two other cases, the *Throughput Forecaster* showed a PEI as having been offloaded two days *after* it was scanned in by the POG at the port, and for two PEIs the error was three days. More significant were two cases in which the report indicated a PEI had been offloaded one day *before* it actually had been. To our knowledge these discrepancies had no effect on the conduct of the offload, but they do highlight the challenge of maintaining accurate visibility during the throughput process.

Another inaccuracy we uncovered was the total number of PEIs to be offloaded. This is an important number because it was the only way to show how the offload was progressing. The total changed every day as items were dropped or added. The table below shows total PEIs appearing in three different reports. We did not have reports for all days.

Table 5. Discrepancies in total PEIs to be offloaded

Report	Total PEIs				
	4-May	5-May	6-May	7-May	8-May
Throughput Forecaster	490	495	502	509	
Offload/Throughput Status Report		489	489		
AAOG SITREP			498	503	497

The differences are not dramatic, but they show some of the challenges in keeping up with the changes. We'd expect fewer problems in a full offload since the denominator used in calculating "percent offloaded" would not change.

Other tracking challenges

Tracking the flow of equipment within the Marine Corps system was one challenge. Reconciling the Marine offload data with the Navy's record was another. This occurred every day at 1800 after offload operations had shut down. Whereas the Marine's count PEIs, the Navy records "footprint items" (FPIs), and each FPI can equal multiple PEIs. This made it difficult to reach agreement on what had been offloaded and to plan for the equipment scheduled to move the following day.

Were information delays/errors a problem?

This is a difficult question to answer. Most of the data discrepancies were not significant considering the scale of the offload. And while it's true that no one seemed to know how many PEIs were to be come off the ships, the differences in the total were small. They may have resulted in an over- or understatement of the progress of the offload to higher headquarters, but only marginally. And again, in a complete offload the total wouldn't change.

What's more important is what these shortcomings suggest about the "system's" potential for handling a much larger pier-side offload running 24 hours a day in conjunction with beach and air operations. This scenario would require far more personnel and scanners to cover day and night shifts and the additional locations. And even with the added personnel we suspect there would be major challenges in keeping up, particularly if the offload sequence and/or distribution of PEIs were to change.

RFID technology demonstration (FB 02)

Two separate RFID systems were demonstrated during *Freedom Banner 02*, one by NFESC and one by UNISYS. Each system consisted of hardware for capturing the tag data and software for controlling the hardware and collecting and displaying the data. The same RFID tags were used by both systems.

For the purposes of this paper, we do not go into too much detail on the differences between systems. The intent is to identify RFID *potential* vice assess the current suitability of either system.⁹ Neither system was used by the arrival and assembly operations organizations to manage the offload.

RFID basics

RFID *tags* are like fancy bar codes. The difference is in the amount of information that can be stored, the ease with which that information can be written to the tag and modified, and hardware/software needed to access and display the information. Tags can be written before or after they are placed on equipment.

RFID *interrogators* are much like bar code scanners, but they don't require people to operate them. There are two types of interrogators: gate readers and wide-area readers. Gate readers are best suited for tracking movement. As such they typically are used along roads or paths traveled by equipment passing from one location to another, such as from the ship at the pier through the POG, MCC, and to the AAOEs. The gate reader interrogates the equipment tags as the equipment passes by.

Wide-area readers have a much longer range and are used to cover a large staging area such as a container operations terminal, frustrated cargo lot, or disassociated cargo lot. Every sweep records equipment within the designated area. This data can then be compared to the previous update to identify items that have entered or departed and what remains.

The RFID demonstration

A total of 134 vehicles on the *MV Williams* were tagged prior to the offload.¹⁰ During the tagging process, Marines noted the vehicle tag and serial number so that data could be written to the tags. This was done using TIPS software. Each tag contained dimensional data, NSN, serial number, and the unit to whom the vehicles were to be distributed, according to information contained in the master offload file. The master offload file was preloaded onto the laptops used by both RFID systems so that the tag data could be properly associated as it was collected. The actual tag writing was done on the ship in about four hours.

Two gate readers were used, one at the POG IN site and one at the AAOE entrance. A wide-area reader was placed at the MCC. In this way tag data could be

⁹ The Army uses RFID technology all around the world to track movement of equipment and personnel with accuracy rates approaching 100 percent.

¹⁰ For a detailed account of the tag writing, interrogator set-up, and data collection process, see the After Action Review submitted by the UNISYS rep.

recorded during each phase of the throughput process. It took roughly three hours to set-up the three sites with approximately five Marines from the POG.

Collecting and processing the tag data

Each RFID system collected and processed the tag data in much the same way. Tag data on vehicles passing by the gate readers (or in the area covered by wide-area reader) were relayed by solar-powered radio frequency links to computers that processed the data. Data collected by the UNISYS system was uploaded to a regional server located in Korea so that it could be viewed on the United States Forces Korea (USFK) In-transit Visibility (ITV) web site. This was done first via the LAN and subsequently by phone line when the LAN got too congested. The web site allows users to run pre-designated queries on the data. Uploading the offload data onto the USFK ITV site meant that it was viewable by a much wider audience. Two Iridium Data Terminals were brought to the demonstration to transmit data via satellite, but attempts to use these terminals were not successful. Direct satellite transmission would be useful either as a primary or back-up means to a LAN or phone lines.

The SAVI Industries system used by NFESC involved two sets of laptops. One set was used to receive the tag data from the interrogators and send it via file transfer protocol (FTP) to a second set of laptops equipped with software to process and manipulate the data. These laptops were preloaded with the master offload file allowing the computer to correctly associate the tag data as it was collected. The software for viewing the data also was able to export the data to MDSS II so that it could be updated with the information collected from the tags.

Once the equipment was set-up, personnel needed only monitor the data transmissions. With the exception of these individuals (one UNISYS and four NFESC reps) and a single Marine stationed at the POG IN gate reader to direct vehicles, no additional presence or action was required.

The *frequency* with which tag data was collected, transmitted, and uploaded also varied. Data captured by the UNISYS system was uploaded to the USFK server every 15 minutes so as to limit the size of the files. These files typically took as few as twenty seconds to upload using a modem. NFESC's SAVI system was set-up to transmit new data every five minutes. This contrasts sharply with the *two-hour intervals* established for the bar code scan updates. More significant, however, is that the data was automatically associated with the offload plan and almost instantly updated. The data could then be sorted and displayed in a variety of ways in *near real time*. *Allowing this data to be viewed by the MEB commander would eliminate the need for status reports.*

Displaying the data

Theoretically, data can be displayed in any manner desired by the user. The queries available through AVM allowed the user to sort by location, serial number, TAMN, MSE, etc. Below are two snapshots taken from AVM. The first shows all PEIs at the MCC.

AssetViewer

Page Viewed At: 5/6/2002 3:22:07 AM

Search Results

Show Location(s):

Location Search Results

ID#	Serial Number	TAG ID	Description	UNIT ID	Last Location	LAST PWRD	Last Update Time
202801027000	50000	DL100	TRAILER, DUMP, 640 ST W/BLV	WBL 0	E-MCC	2002 - MCC	05-27-2002 04:27:11
202801027100	50002	DL100	TRAILER, CARGO, TRP C W/DAW/HMMV	WBL 0	E-MCC	2002 - MCC	05-27-2002 04:12:11
202801027100	50003	DL100	TRAILER, CARGO, TRP C W/DAW/HMMV	WBL 0	E-MCC	2002 - MCC	06-02-2002 04:12:11
202801027100	50117	DL100	TRAILER, CARGO, TRP C W/PPHMMV	WBL 0	E-MCC	2002 - MCC	05-27-2002 03:42:11
202801027100	50109	DL100	TRAILER, CARGO, TRP C W/DAW/HMMV	WBL 0	E-MCC	2002 - MCC	05-27-2002 03:46:11
202801027100	50009	DL100	TRAILER, CARGO, TRP C W/DAW/HMMV	WBL 0	E-MCC	2002 - MCC	05-27-2002 03:42:11
202801027100	50294	DL100	TRAILER, CARGO, TRP C W/PPHMMV	WBL 0	E-MCC	2002 - MCC	05-27-2002 03:42:11
202801027100	50270	DL100	TRAILER, CARGO, TRP C W/DAW	WBL 0	E-MCC	2002 - MCC	05-27-2002 03:42:11
202801027100	50204	DL100	POWER UNIT, 32 HP, 30N	WBL 0	E-MCC	2002 - MCC	05-27-2002 04:12:11
42100102940	50000	DL100	TRAILER, AIRCRAFT, CLST, TRP	WBL 0	E-MCC	2002 - MCC	05-27-2002 03:42:11
20280102960	50000	AL100	RADIO SET, PRC-245	WBL 0	E-MCC	2002 - MCC	05-27-2002 04:12:11
20280102960	50007	AL100	RADIO SET, PRC-245	WBL 0	E-MCC	2002 - MCC	05-27-2002 03:42:11

The offload status reports maintained by the AAOG all focused on the number of PEIs received by each MSE compared to the total expected. This data had to be extracted from the MDSS II scan updates, a process that took hours in some cases. The screen shot below shows how AVM was able to convert the tag data into a stop light chart with the same information almost immediately and at any point in the offload.

AssetViewer

Page Viewed At: 5/6/2002 3:22:26 AM

Offload Status

Offload Status Report:

MSE	Total Expected	Units Delivered	Status
GC	30	9	■
GCX	29	20	■
GCY	22	14	■
GCZ	29	1	■

■ Less than 50% delivered
■ between 50% and 90% delivered
■ greater than 90% delivered

RFID data issues

Several problems were encountered collecting the RFID tag data resulting in processing delays and/or an incomplete/inaccurate data set. Some of the problems were resolved quickly; others will have to be fixed before the next demonstration. When all the data was tallied, the UNISYS system recorded more vehicles leaving the port and entering the AAOE than had arrived at the port. In contrast, the NFESC data showed only a subset of vehicles recorded at the port as having arrived at the AAOE. We know that the vast majority of tagged vehicles made it to the AAOE.

One of the problems involved loss of power to the interrogator at the AAOE sites. Data could not be collected during the time the generator was down and we do not know how many vehicles were missed because of this.

Tags on vehicles that made it to the AAOE were removed and turned off. The AVM software used by the NFESC interpreted this to mean the vehicles had never left the ship, creating inaccuracies in the database.

The TIPS software used by the UNISYS rep was not able to simultaneously collect data and upload it to the server. This was only a problem when the laptop was connected to the LAN, which was very slow at times. The problem was corrected by connecting the laptop to a modem, but not before some vehicles were missed.

Conclusions

A more comprehensive assessment of sensor technology would be based on answers to questions the demonstration could not provide. For example, how much would sensors and interrogators cost? Who would own and maintain them? What training would be required? How much bandwidth would they consume? How durable would they have to be?

These issues aside, RFID technology would appear to offer significant advantages over the existing Marine Corps offload management system. Automating the data collection process would eliminate the need for scanning personnel and equipment, as well as those personnel responsible for processing the offload data.

Improving the accuracy of the data will reduce uncertainty over what's been offloaded and where it is in the distribution process. This will eliminate the need for lengthy reconciliation efforts.

Having access to the data in near real time will provide greater positive control over equipment, making it easier to reallocate gear if the commander's priorities change. Allowing this data to be viewed by the commander and his staff will eliminate the need for status reports.

Appendix A: Offload tracking personnel

This appendix contains a list of individuals in the AAOG, LFSP HQ, POG, MCC, and each AAOE involved in some way with the tracking, distribution, and accountability of equipment as it was offloaded during FB 02. We do not include Navy, BIC, or POG personnel. Data on personnel for the AAOEs is notional. There were five AAOEs (CE, GCE, ACE, CSSE, and NSE), each with roughly 7 personnel, or 35 for all AAOEs. Of this total, we estimated a total of 10 Marines (two per AAOE) were needed to scan equipment and create CMRs.

Org Sub Total	Arrival/Assembly Org	Billet	Assignment	Tracker	Total Trackers	Org Total	% Org Total
1	AAOG	OIC		1			
2		INTEL OFFICER					
3		INTEL CLERK					
4		COUNTER INTEL OFF					
5		LANDWARD SEC OFF					
6		FORCE PROT OFF					
7		OPERATIONS OFFICER		1			
8		ASST OPS OFFICER		1			
9		AAOG CHIEF		1			
10		ASST AADG/LOGAIS CHIEF		1			
11		MDSS OPER		1			
12		SUPPLY OFFICER		1			
13		SUPPLY CLERK		1			
14		CE LNO		1			
15		GCE LNO		1			
16		ACE LNO		1			
17		CSSE LNO		1			
18		LOG OFFICER		1			
19		LOGISTICS CHIEF		1			
20		CLERK/DRIVER GA					
21		ADMIN CHIEF		1			
22		STRATEGIC MOBILITY OFFICER		1			
23		EMBARK NCO		1			
24		TRANS COORD		1			
25		ROADMASTER					
26		ROADMASTER					
27		COMM OFFICER		1			
28		RADIO OPER		1			
29		RADIO OPER		1			
30		DATA SYS OP		1			
31		DATA SYS OP		1			
36		PAO					
37		PA CHIEF					
38		PROTOCOL CHIEF			23	38	61%
1	LFSP HQ	LFSP CO		1			
2		LFSP XO/OPS OFF		1			
3		LFSP 1STSGT		1			
4		LANDING SUPPORT CHIEF		1			
5		LFSP OPS CHIEF		1			

Org Total	Sub Arrival/Assembly Org	Billet	Assignment	Tracker	Total Trackers	Org Total	% Org Total
6		LFSP LOG OFFICER		1			
7		LFSP LOG CHIEF		1			
8		LOGA/S NCO		1			
9		EMBARKER/LOGA/S NCO		1			
10		LOGA/S CLERK		1			
11		LOGA/S CLERK		1	11	11	100%
1	POG	POG OIC	POG HQ	1			
2		POG SNCOIC	POG HQ	1			
3		POG CHIEF	POG HQ	1			
4		LS TEAM LEADER	COT LOT	1			
5		LS TEAM LEADER	DCL	1			
6		LS SPECIALIST	DCL	1			
7		LS SPECIALIST	DCL	1			
8		LS SPECIALIST	DCL	1			
9		LS SPECIALIST	DCL	1			
10		LS SPECIALIST	DCL	1			
11		LS SPECIALIST	DCL	1			
12		LS SPECIALIST	DCL	1			
13		LS SPECIALIST	DCL	1			
14		LS SPECIALIST	DCL	1			
15		LS SPECIALIST	DCL	1			
16		LS SPECIALIST	MCC	1			
17		LS SPECIALIST	MCC	1			
18		LS SPECIALIST	MHE	1			
19		LS SPECIALIST	MHE	1			
20		LS SPECIALIST	MHE	1			
21		LS SPECIALIST	POG HQ	1			
22		LS SPECIALIST	POG IN	1			
23		LS SPECIALIST	POG IN	1			
24		LS SPECIALIST	POG IN	1			
25		LS SPECIALIST	POG IN	1			
26		LS SPECIALIST	POG IN	1			
27		LS SPECIALIST	POG IN	1			
28		LS SPECIALIST	POG IN	1			
29		LS SPECIALIST	POG IN	1			
30		LS SPECIALIST	POG IN	1			
31		LS SPECIALIST	POG IN	1			
32		LS SPECIALIST	POG IN	1			
33		LS SPECIALIST	POG OUT	1			
34		LS SPECIALIST	POG OUT	1			
35		LS SPECIALIST	POG OUT A	1			
36		LS SPECIALIST	POG OUT A	1			
37		LS SPECIALIST	POG OUT A	1			
38		LS SPECIALIST	POG OUT A	1			
39		LS SPECIALIST	POG OUT B	1			
40		LS SPECIALIST	n/a				
41		LS SPECIALIST	Medical				
42		LS SPECIALIST	Medical				
43		LS SPECIALIST	n/a				
44		LS SPECIALIST	Medical				
45		LS SPECIALIST	Duty Recovery				

Org Sub	Arrival/Assembly Org	Billet	Assignment	Tracker	Total Trackers	Org Total	% Org Total
46		LS SPECIALIST	Beach Detail				
47		LS SPECIALIST	Beach Detail				
48		LS SPECIALIST	Duty Recovery				
49		LS SPECIALIST	Beach Detail		39	49	80%
1	MCC	MCC OPS OFF		1			
2		MCC CHIEF		1			
3		MCC ASST. CHIEF		1			
4		LOGS REP		1			
5		LOGS REP		1			
6		MT OPR					
7		MT OPR			5	7	71%
1	NOTIONAL AAOE x 5	ASST HQ COMMANDANT					
2		EMBARK NCO		1			
3		SUPPLY CLERK		1			
4		MT OPERATOR					
5		MT OPERATOR					
6		AUTO MECH					
7		GENERATOR REPAIRMAN			10	35	29%
Totals					88	140	63%

Appendix A2: Unisys After Action Report

AFTER ACTION REVIEW Cobra Gold 2002 (Thailand)

Automated Information Technology (AIT) / In-Transit Visibility (ITV)

I **MISSION**

Three Force Service Support Group (3FSSG) worked in conjunction with Unisys to provide in-theater Intransit Visibility (ITV) for vehicles being off-loaded into Thailand in support of the exercise Cobra Gold 2002. The Automated Information Technology (AIT) used to support this Joint Chiefs of Staff (JCS) exercise was Radio Frequency Identification (RFID) tags. Additional equipment was used in support of the exercise, but this AAR will be limited to the support provided by Unisys Corporation.

II **BACKGROUND**

The RFID equipment used during the exercise is equipment that had been purchased by the Naval Facilities Engineering Service Center (NFESC) for testing and evaluation. The equipment used by the Unisys Representative was extra equipment that was not required by the personnel from NFESC. This equipment included two SAVI solar power kits, three Savi Interrogators, two SAVI RF Links, and two tripods. TIPS was loaded on two notebook computers, while the other test systems used by NFESC were loaded with SAVI Asset Manager. The one computer had Windows 98 and the other had Windows 2000 installed as the operating system. The software and configurations used by the Unisys Representative are similar to that which the US Army in Korea has used since 1994.

Once the data has been uploaded to the regional server located in CP Henry, Daegu, Korea, the information is made available on the USFKITV Home Page. The data is stored in a huge database and the web site allows a user to run pre-designated queries to obtain the information required. These are as simple as selecting queries; then query on a single key data element; enter "CG02" in the free text box, and all 134 tags associated with this movement are displayed. One could also select "Operation/Exercise" and then select CG02, which will then display the 134 tags. To support the exercise, the RF Tags were written so that a user to easily query for the group of tags they are interested in. The server and the home page were recently upgraded to meet DoD/DA/USFK/EUSA security requirements. This includes the requirement for a user account and password. Access to the site is only available to personnel trying to access for a computer on a military LAN or .mil.

III **OBJECTIVES**

- Provide visibility of off-load of selected equipment from the MV Williams through the port to the AAOE.
- Test various equipment and software to determine what is available, strengths, weaknesses and capabilities.
- Determine likelihood of utilizing Radio Frequency Identification (RFID) equipment to reduce the required number of personnel to support port operations.
- View the capabilities of the equipment, accuracy, reliability, and web page information for reporting off-load status, and the ability for higher headquarters to view this data via the web site to eliminate the requirement to submit said reports.
- Encourage use of ITV system at all command levels, as the system would be available during contingency operations.

IV CONCEPT

Based on a request from BG Williams, Commanding General, 3FSSG, a Unisys Representative was deployed to support tracking vehicles off-loaded from the MV Williams in support of Cobra Gold 2002. The NFESC was also deployed in-theater to test similar equipment and software. TIPS software was loaded on two systems for working with three SAVI interrogators. One computer was installed in a container not far from where the vehicles were lifted on the pier. The other interrogator was placed in an area next to where the vehicles would depart the port. The second computer and third interrogator were installed at an intermediate staging area to show that arrival.

A thorough analysis of the business process was not completed prior to the installation of the equipment. It was a matter of dealing with the site, power availability and communications assets that were made available.

V PREPARATION

A. Site Surveys. As stated above, site surveys were not completed.

B. Communication. Each site required some form of communications for the data to be uploaded to the USFKITV server located at Camp Henry, Daegu. This coordination began with the POC. He coordinated so that LAN support was available at one site and a phone was available on the other site. The phone dialed into the Army TSACS that allow for NIPR connectivity to the USFKITV server. Future communication requirements must be included as part of the planning process.

C. Training. Training was provided to various people of the use of the ITV web site. One individual was also trained on the use of TIPS and writing tags.

D. USFKITV Home Page. It was the intent of the command to utilize the existing home page that had recently been upgraded to meet DoD/DA/USFK/EUSA security requirements. This included the requirement to have a user account and password. Individuals were notified to request an account and this was accomplished. No changes were made to the existing web page to meet requirements for this exercise.

VI EXECUTION

For the purpose of this report, "execution" is defined as the period of time from when the Cobra Gold 2002 tags were written till they were taken off the equipment at the AAOE. There were 134 tags written and used for this exercise.

A. Placing Tags on Equipment and Entering Data into TIPS. Upon arrival in-theater we immediately began writing tags for the equipment. We stopped this process because of time constraints. We determined that, with the limited amount of time we had, additional support required, and the amount of time it would take to enter the data, we changed our process as follows. Our original intent was to write the tags and have 10 Marines match the tag up with the vehicles. As stated above, we didn't have time to write these tags prior to when we needed the Marines. Therefore, we had the Marines take the tags to a vehicle, attach the tag, write down the tag number and serial number, and bring that information back to the processing area where that data can be added to TIPS. We did have an export file generated by a Marine Corps system, but because of the flaws in the data, we could not properly import the data. So we prepared a template using TIPS with the key data desired to be available on the tag and on the ITV server. This template was then used for writing all 134 tags. The data included the Unit information, weight, cube, NSN, serial number, nomenclature, etc. Once the data was entered into TIPS, which took approximately three hours, it was time to write the tags.

B. Writing Tags using TIPS. The tags were spread on 4 different levels of the ship. We were able to read all the tags from one location on Deck B, but could not write to all the tags. Therefore, we took a computer and interrogator to each level of the ship. We then had a hidden compartment on Deck C that we also had to enter. Some of the tags from other decks could be written through the different levels, but we had to go to each level to accomplish the task. There was one tag that for some reason could not be written on-board the vessel. From an admin area, wrote the data to a different tag and replaced the bad tag with a good tag. Because of a bad phone line at that particular time, we sent the files associated with each tag via e-mail to the DBA to upload for us. This was accomplished we before the ship began to off-load.

C. AAOG Read Station. It was decided then to take available equipment and install a read site to cover the port entry and port exit. The vehicles would drive by the Port In site at about 5 miles per hour. The time in the interrogation zone was approximately 15 seconds. This amount of time was more than adequate to catch tags passing the read site. The Port Out interrogator happened to be located directly over the vehicle staging area. This required you to look carefully at the web page to determine that the tag was not longer being seen to determine that it was no longer at the site. A

system was placed in the AAOG office connected to an interrogator, working through 2 RF links and then a second interrogator covering the port exit. SAVI solar power kits powered all the RF links and interrogator at the port exit. Since the port operations were limited to daylight operations only, and had a good strong source, this provided more than adequate power for these items. The computer used for read operations was originally connected to the LAN. This LAN ran through tactical assets that were shared by many different units. Because of this, the connection was very slow requiring at times 15 minutes for a single upload of multiple files. A single file could take as much as 5 minutes. With the issue of using ODBC and, the time required for the upload meant tags could not be collected at the same time. Therefore we switched to a phone line that allowed for simultaneous upload and tag collection. This worked extremely well until some disconnected the phone line cause an interrupt in connectivity. The data continued to be collected and was uploaded when the problem was resolved. The uploads where set at every 15 minutes to limit the size of the files. Using modem, the file could be uploaded in as little as 20 seconds. This was far better than the same 5 minutes via LAN.

D. AAOE Read Station. With the availability of one more interrogator, we decided to install one more read station at the AAOE. This interrogator was placed slightly off the road capturing the data as the tag traveled by at approximately 5 miles per hour. This provided similar equipment at each location for analysis, comparing reliability, ease of use, requirements for installation and support. This particular site was connected using the existing Tactical LAN on-site. The upload frequency was set at 15 minutes to limit the size of the file. At this particular site the upload time was reduced and considered reasonable.

E. Results. A comprehensive analysis could not be completed because of several factors. Each site was not installed and operational prior to the start of vehicle processing. The business process was not followed throughout allowing each tag to have the opportunity to be seen at each read station. Because of time constraints, sites had to be disassembled prior to all vehicles being off-loaded. This data was all obtained from the USFKITV web page.

1. AAOG PORT-IN CHUK SAMET	54 TAGS READ
2. AAOG PORT-OUT CHUK SAMET	125 TAGS READ
3. AAOE UTAPAO	77 TAGS READ

VII FINDINGS / RECOMMENDATIONS

A. Site Survey/Business Process.

Finding. Knowledgeable personnel to determine the best fit and use of the ITV equipment were not able to conduct a site survey. Had a site survey been completed, several of the sites would have been relocated to a better location to prevent over interrogating tags and limiting the data that is collected to that which pertinent to the event. An example of this is placing the Port Out interrogator over a vehicle staging area versus placing up the road to act as a true truck exit site. The other issue was that the

business process as briefed was not followed which would have had the vehicles depart the staging area within 5 or so minutes of arrival at the Port Out area. The interrogators had to be adjusted to fit communications, power and the operational situations.

Recommendation. Conduct a site survey with knowledgeable personnel to best determine interrogator placement.

B. TIPS unable to interrogate while uploading using the LAN.

Finding. This problem with the software has been identified and is being worked on by the programmers. The slow LAN magnified the need for this to be corrected. The LAN connectivity in a controlled environment, such as that used in Korea would allow an upload to be completed within a matter of seconds. It is not known how many tags were missed at the Port In site because of this problem. The time to upload one tag at this site could take as much as 5 minutes. Once the phone line was used, this problem was illuminated.

Recommendation. Correct problem with the TIPS software to allow simultaneous upload using the LAN while the software is interrogating.

C. Writing Tags

Finding. The process used in writing tags worked out extremely well for this particular situation. In previous exercises we had problems matching the tag that had been written with the container or vehicle that it was to be attached. In some cases we weren't 100% sure that the container or vehicle was even in the area. By placing the tag on the container or vehicle prior to writing it and then matching it up on the computer later made the process much easier and less manpower intensive. The Marines took the tag out to a vehicle, wrote down the tag number and the vehicle serial number. In a situation where the data has been imported into the database, one could write down the tag number, serial number, TCN and type vehicle. The additional data would be used for a quality control check. Then you have to be able to move the computer and interrogator to the area where the vehicles are located. To prevent a tag being placed on a vehicle that could be bad, turn the batteries on and conduct a tag status check.

Recommendation. When possible consider using the process used in this particular exercise for writing tags. Or schedule sufficient time to write all tags prior to mounting any of them.

D. Limited Amount of Equipment Tagged.

Finding. Only a portion of the equipment that was off-loaded was tagged. This did not allow the operations personnel an opportunity to utilize the systems that were

made available to them. The utilization of this equipment would have required double work instead of tagging everything which would allow the computers to do the tracking work them. In this situation, they could have completely evaluated the data and determined exactly what data they need. They could have then looked at the site to get near real time visibility at all levels of command. Manual tracking and assessments would then be done by exception significantly reducing the personnel required to operate the port and track port operations. This could also eliminate the need to submit port operations reports to higher headquarters.

Recommendation. Tag all assets involved with an operation/exercise as part of the unit movement.

E. Identify Communications, Power, etc Requirements as Part of the Planning Process.

Finding. All support requirements need to be identified as part of the planning process.

Recommendation. Identified required support as part of the planning process.

F. Tags at Current Location.

Finding. It took effort to identify those tags that were at the location of the interrogator at the time of the last upload. There is often a need to know which tags are currently in range of the interrogator. This would assist in determining how many vehicles or containers need to be moved or even how many pieces of equipment or containers are at a given location at a given time.

Recommendation. Identify a column or asterisk or something on the web page that would identify that a particular tag was at the site or in range of the interrogator when the last upload occurred.

G. Use of the Iridium Data Terminal.

Finding. Two Iridium data terminals were brought to the site to test and see if they could be used for data communications requirements. We had the opportunity to test one using the TIPS software. This was done to see if it could be used as part of the Fly-Away Kit (EEDSK) to provide the communications required. Neither of the two terminals was successfully used on any system. The terminals had been tested using the commercial chips and just prior to the exercise, the chips were changed to DSN chips. They had not been tested and instructions were not provided. An additional issue is that there was no software or lights or anything telling you there were a problem with the

system. You could not tell if you were connected to a satellite, that it was successfully dialing out or anything.

Recommendation. Continue testing.

VIII CONCLUSION

Use of the RFID system was a success. The system worked as designed and provided the information on the ITV web pages, JTAV and GTN. Use of the equipment allowed for coverage of off-loads and vehicle movements for those vehicles tagged. This data was then available to all levels of command simultaneously.

Appendix A: RFID Sites used

INTERROGATOR SITE	LOCATION	TYPE SITE
837th Trans (Pier 8) Pier	Pusan	Active
837th Trans (Pier 8) Truck Gate	Pusan	Active
Pusan Storage Facility	Pusan	Active
MSC-K Rail Gate	CP Carroll	Active
Gwangju AB	Gwangju	Inactive
Jochiwon Rail Station	Jochiwon	Inactive
Suwon Rail Station	Suwon	Inactive
CP Casey Rail Head	CP Casey	Temporary
Masan Interchange	Masan	EEDSK
Sunchon Interchange	Sunchon	EEDSK
Gwangju AB	Gwangju	EEDSK
Yangsan ICD	Yangsan	EEDSK
Kyeongsan Rest Area	Kyeongsan	EEDSK
Chupungnyong Rest Area	Chupungnyong	EEDSK
CP Carroll Gate	CP Carroll	EEDSK
FROKA Boundary Change		EEDSK
FROKA Release Point	CP Eagle	EEDSK
TROKA Boundary Change		EEDSK

Additional Sites Activated to Exercise Equipment

INTERROGATOR SITE	LOCATION	TYPE SITE
Daegu (K2) AB	Daegu	Inactive
Kimhae AB	Pusan	Inactive
Miryang Rail Station	Miryang	Inactive

LEGEND:

- Active = A site that has been installed is operational 24/7
- Inactive = A site that has been installed but is only turned on in support of exercises or contingency
- Temp = A site that is installed only for the duration of the exercise or contingency requirement
- EEDSK = Portable kit that is setup to cover a specific event. The event could be of short duration or extended duration.

Appendix A3: SAIC Iridium Report

IRIDIUM Application

Cobra Gold Review

5 June 2002

Prepared for:
Naval Facilities Engineering Service Center
1100 23rd Avenue
Port Hueneme, CA 9303-4370



Prepared by:
Science Applications International Corporation
Advanced Information Technology Group
Expeditionary and Littoral Warfare Division
Point Loma Technology Center
4015 Hancock Street
San Diego, California 92110-5155



Security Classification – UNCLASS

Subject: Iridium Application during Exercise Cobra Gold 02 in the Kingdom of Thailand

1.0 Overview

The scope of the effort to support Cobra Gold was execution support and technical services support to the in support of 3rd FSSG during the Cobra Gold exercise of 2002. Specifically, engineering services were provided to perform an end-to-end test of the RFID system to include, MDSS II, the Savi RFID hardware/software system, and the Asset Viewer Manager system. Technical personnel also provided software development work to fix errors and stabilize the Asset Viewer Manager for use in CG. Technical personnel also provided engineering services to support the use of Iridium Satellite Phones to view Cobra Gold exercise data from the Continental United States. The intent of the Iridium application was to provide a communications link using two IRIDIUM terminals that will allow the AVM running outside the Marine Corps LAN used in Cobra Gold to be viewed at a second location.

2.0 Background.

Iridium difficulties and challenges became readily apparent when upon contract award when it was discovered no devices could be provided until shortly before the exercise commenced. While it was agreed this would limited our abilities to perform the Iridium link, it was also agreed that we would press on and make the best attempt possible based on time available and complexity engaged. This reduced timeline handcuffed the technical personnel due to the fact support personnel and the AVM system had to be deployed and equipment set-up executed and ops checked prior to the commencement of the MPF operation. Personnel deploying departed CONUS on 25 April. The Iridium devices arrived at the contractor's site in San Diego CA the evening of Thursday, 18 April. On inspection of the equipment, it was noted and reported that only 2 of the 3 Iridium devices appeared to function. One of the devices was inoperable. It was also noted that there were no power supplies provided with the equipment. Due to short time frames, technicians attempted to locate applicable power supplies via other contacts, but devices located were not suitable. Additionally, technicians were unable to locate appropriate power supplies at commercial locations. Simultaneous with the power supply search, technicians contacted identified POC who was unable to assist; however, he did provide technical contact at NAL Research. Contact was made with the NAL POC on Monday, 22 Apr who agreed to send power supply's and identified that Iridium SIM cards were incorrect. NAL POC FedEx'd proper equipment that was received on 24 & 25 April. The system was set up in a test environment and ops checked for connectivity. Additionally original SIM cards were removed and replaced with the DSN SIM cards provided by the NAL. At the time of the test, technicians were able to establish connectivity on 25 April between the 2 Iridium devices hyperterminal to hyperterminal using the commercial SIM cards originally provided. However, they were not able to establish an interface with the AVM server though an effort had been made to setup server beforehand based on research without having the devices in hand. NAL POC was unable to assist due to non-availability. Decision was made to deploy the Iridium devices

with the Team and to continue efforts, in concert with NAL, to develop AVM interface and run test once the AVM and devices were set up in Thailand. At this point, technicians re-configured the SIM cards with the DSN SIMS received from NAL.

On arrival in Thailand and equipment setup, the Iridium device was emplaced. Due to required DSN access, technicians in CONUS had to make special arrangements to acquire DSN access to conduct a connectivity test. After several attempts and discussions with the NAL, parties were able to connect – again, hyperterminal to hyperterminal and send digital messages to and from. However, access to the AVM server was still unable to be accomplished. On continued discussion with NAL technicians, both groups of technicians believed a work around could be developed, but also felt that without laboratory access to the server and phones – and time and distance between platforms, that further attempts would be futile. Lack of experience by both group of technicians with DSN SIMS, in addition to very limited availability of NAL technical personnel, exacerbated the difficulties.

3.0 Technical Observations/Challenges

- Not enough time to integrate/not enough time, nor availability, of right NAL personnel to determine best solution for integration.
- Unclear instructions on set up, primarily in what the connection string (phone number) should be dialed.
- Confusion with the SIM Cards between commercial and DSN and the different combinations required to dial.
- When attempting to use RAS versus hyperterminal, the Iridium server would never detect the ring state. Troubleshooting this became untenable because: None of the technician groups had a clear cut solution; dialup via limited access of DSN; and the physical separation between CONUS and OCONUS test sites.
- The integration method used was to set up the Remote Access Server (RAS) on the server connected to the Iridium modem so client machines could dial in to that machine and access the web server. Hyperterminal is an application that directly sends data to and receives data from a modem. Use of RAS uses "standard" Microsoft applications that come with the Windows operating system. To dial to RAS uses standard dial in to a Virtual Private Network. The RAS automatically detects a dial in, does authentication, and then assigns an IP Address to the client machine, putting the client on the same local area network. This configuration was tested using a "standard" modem on the Iridium server in place of the Iridium modem, so we knew the technology worked. It just wouldn't work when we installed the Iridium modem.
- This alternative probably wasn't the best after talking to the right people, but it was agreed it was the only choice due to time and resources. Other ways we may have

done this: send the SAMS file over hyperterminal to a server CONUS for processing and allow CONUS users to link to a website locally; use the Iridium "gateway" configuration.

Appendix B

Test Plan Documentation

Appendix B1: Concept of Operations

Appendix B2: System Setup and Operation

Appendix B3: Safety and Administrative

Appendix B4: RFID and Iridium System/Component Descriptions and Connection

Appendix B1: Concept of Operations

1. CONOPS

General

The CONOPS for the experiment is presented in this appendix. The setup location and purpose of the equipment used in the experiment is discussed here. The planned and as-tested configurations of the systems used were different. These differences are noted in the appropriate sections. This discussion is provided at a general level. More specific information about the setup and operation of the equipment is provided in Appendix B2.

The two principle reasons that the as-tested systems were different from the planned systems are shipping delays and software conflicts. The shipping delays prevented the use of all the gate readers that had been planned. The shipment of gate readers did not arrive in time to set them up for the offload. Software conflicts prevented data being transmitted using the Iridium satellite system. Hyperterminal was used establish the dial up connection to the satellite from the laptops containing the RFID data. The Asset Viewer Manager (AVM), which hosts the RFID data, must run on a Windows operating system. Hyperterminal would not function properly when being used to dial the satellite with Windows 2000 running.

Three independent systems were operating to provide TAV capability during this experiment. One system was the barcode scanning system currently used in the field by the Marine Corps. Detailed information about that system and how it was used during this experiment is contained in the CNA After Action Report in Appendix A1. The other two systems both used the same RFID equipment but different information systems. One system pushed RFID data to the Army ITV server, providing TAV capability. Details on this system can be found in the Unisys After Action Report located in Appendix A2. The other system provided TAV capability using the AVM. The AVM was populated by RFID data also.

1.1 Overview

Freedom Banner/Cobra Gold (FB/CG) 2002 is a combined and joint exercise that was conducted in Thailand. The TAV experiment was focused on the MPF operations that were conducted during the exercise. The MV LUMMUS and MV WILLIAMS were offloaded using an in-stream-to-pier process. The ships were 3 to 4 miles offshore. The Marine Corps was using the barcode system to track all equipment as it was offloaded from both ships and transported to the end users. Pen and logbooks were used as backup for the barcode system. The RFID system was used to track selected equipment being offloaded from the MV WILLIAMS.

The port to which the equipment was transported using Navy lightering is called Chuksamet Port. The Port Operations Group and the Movement Control Center were located at Chuksamet Port. The Major Subordinate Commands to which the equipment was transported was located in Samaesan. Samaesan is approximately 25 minutes by vehicle from the port. See Figures 1 and 2 for location reference.

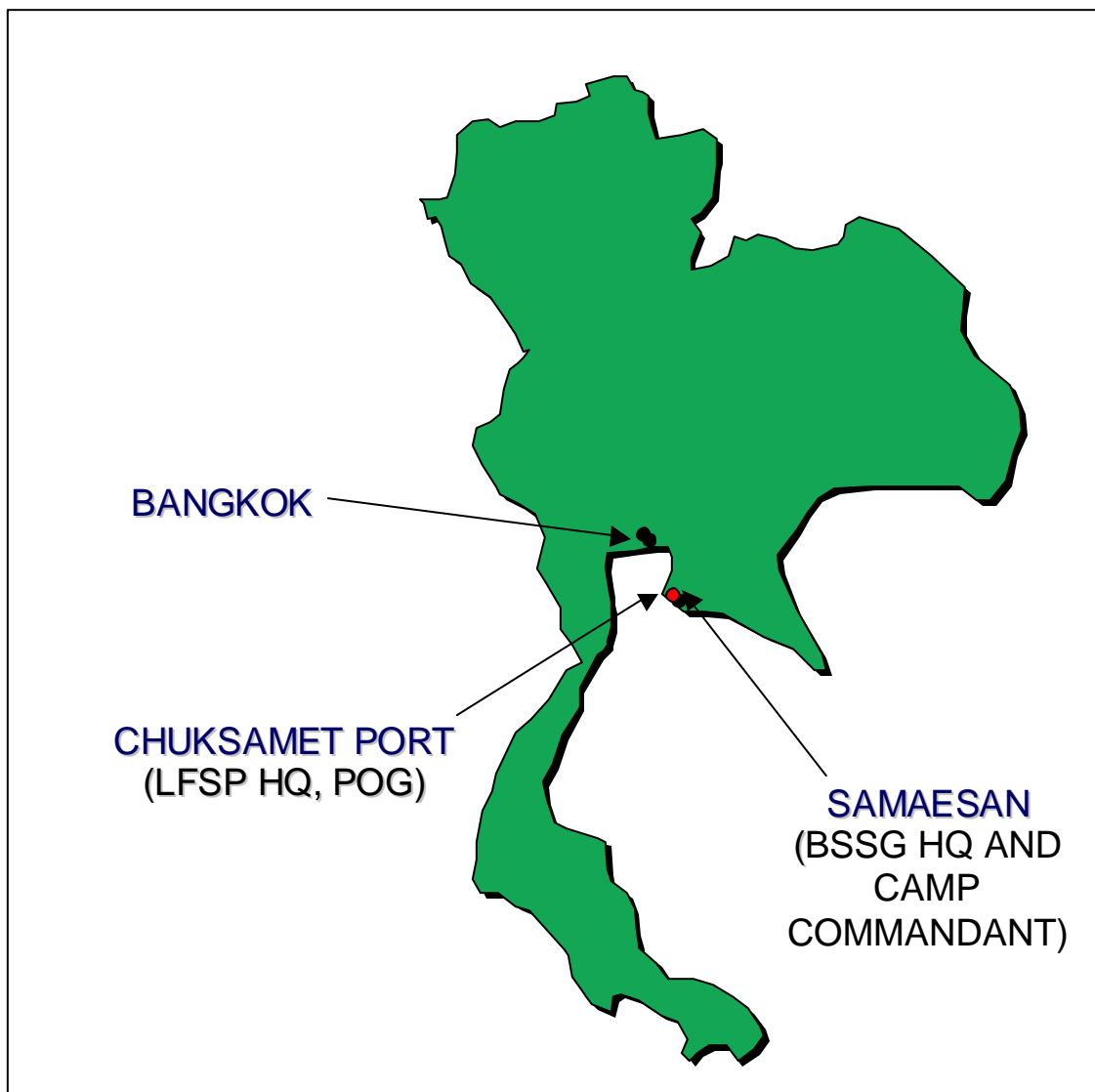

Figure 1: Thailand

1.2 MV WILLIAMS

RFID tags were applied to selected PEI while onboard the MV Williams. The plan was to tag 261 PEI. This plan was based on the Unit Deployment List that was provided by 3rd FSSG prior to the experiment. Data sheets were produced based on this UDL. An abbreviated data sheet is provided in Appendix C2 for reference. During

the tagging process, the use of the data sheets was modified. It was determined to be simpler to use blank data sheets and record only the tag ID and the PEI serial number.



Figure 2: Chuksamet Port

This allowed the person responsible for applying a tag to choose any vehicle that was to be offloaded instead of looking for a specific vehicle that was to be offloaded before applying a tag.

1.3 Chuksamet Port

The Arrival and Assembly Operations Group was located at the port. As a result, the Port Operations Group (POG), the Movement Control Center (MCC) and the Landing Force Support Party (LFSP) were also located at the port. RFID readers were set up at the port to capture PEI traffic flowing through this location on the way to the AAOEs. Communications and information systems were also established to provide the TAV capability.

Figure 3 shows the planned locations of the RFID readers at the port. Location 1 would be a fixed reader (~300-foot read radius) for providing visibility of equipment located in the Frustrated Equipment Area. Locations 2 and 3 would be gate readers providing visibility of equipment exiting the MCC and entering the POG, respectively. Figure 4 shows the as-tested locations. Locations 1 and 3 indicate where two fixed readers were installed. These readers captured RFID tag data that was used to populate the Army ITV site. These readers provided the ITV server with identification of PEI within the POG and MCC. Location 2 served as the POG-In chokepoint and was equipped with a gate interrogator. This gate reader captured RFID tag data that was posted onto the AVM. A third fixed reader was installed at location 4. This served as the MCC exit point to collect RFID data for the AVM. The computers operating the RFID system and the AVM computer were set up at the LFSP. The equipment and data flow at the POG, MCC and LFSP are described below.

1.3.1 POG

The POG is the first point at which TAV data was captured on equipment disembarking the MV WILLIAMS during operations. One gate reader (Location 2 in Figure 4) was set up to capture the PEI being removed from the Navy lighters as they arrive at the port from the MV WILLIAMS. This gate reader wirelessly transmitted RFID data to the AVM computer located at the LFSP. This capture point served as the entrance to the POG. One fixed reader (Location 1 in Figure 4) captured PEI located in the POG and transmitted this information to the ITV server. Refer to the Unisys After Action Report in Appendix A2 for more detailed information on the ITV system.

At the POG, the Marines were using barcode scanners to capture visibility of all equipment being offloaded from the MV LUMMUS and MV WILLIAMS. Barcode scanning information was periodically uploaded via a wireless RF link to a computer at the LFSP that was running MDSS II. Pen and logbooks were used as a redundant backup to the barcode scanners. Refer to the CNA After Action Report in Appendix A1 for more detailed information on the barcode scanning operations.

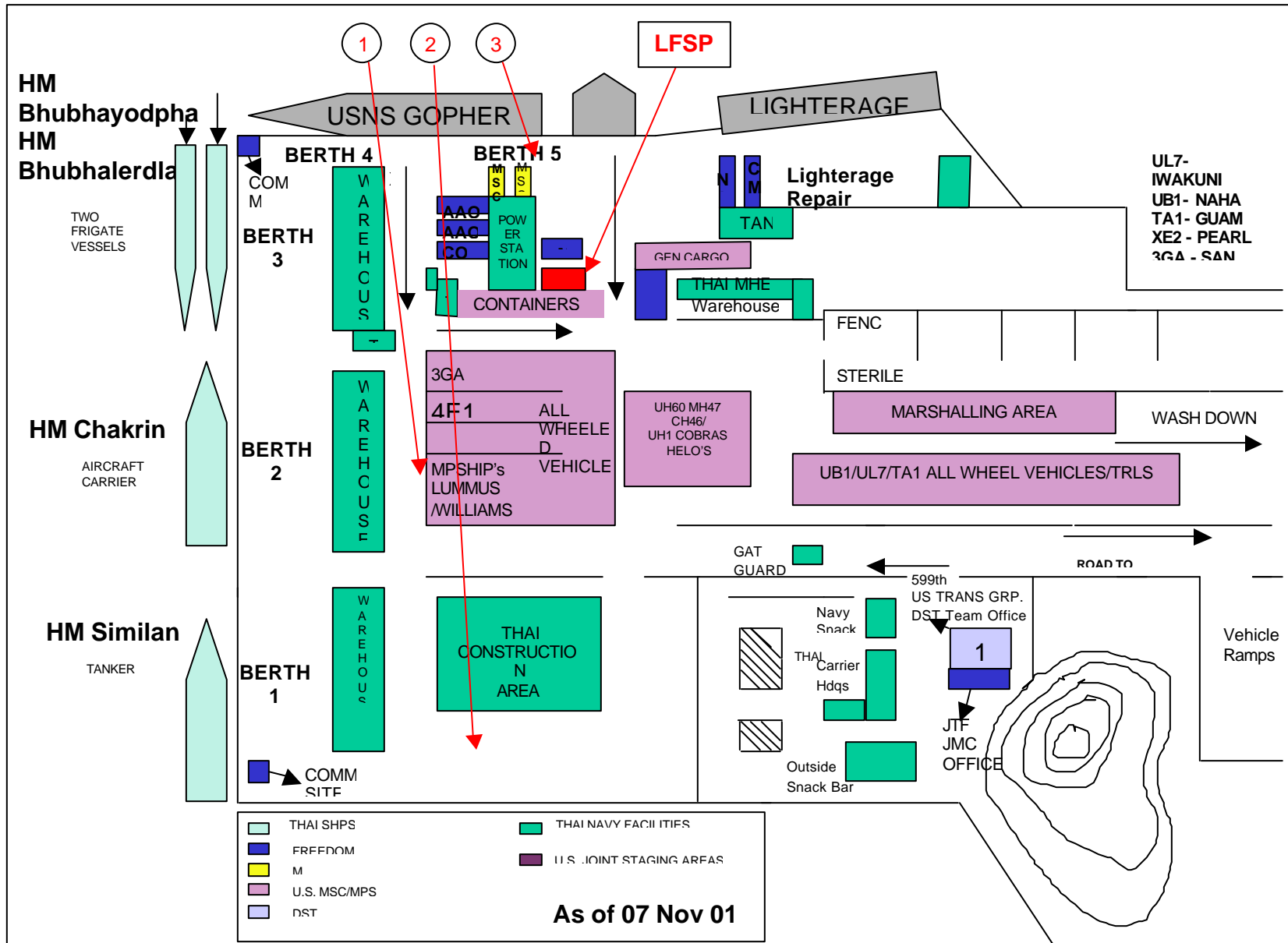

**Figure 3: Chuksamet Port Area Diagram
Planned Reader Locations**

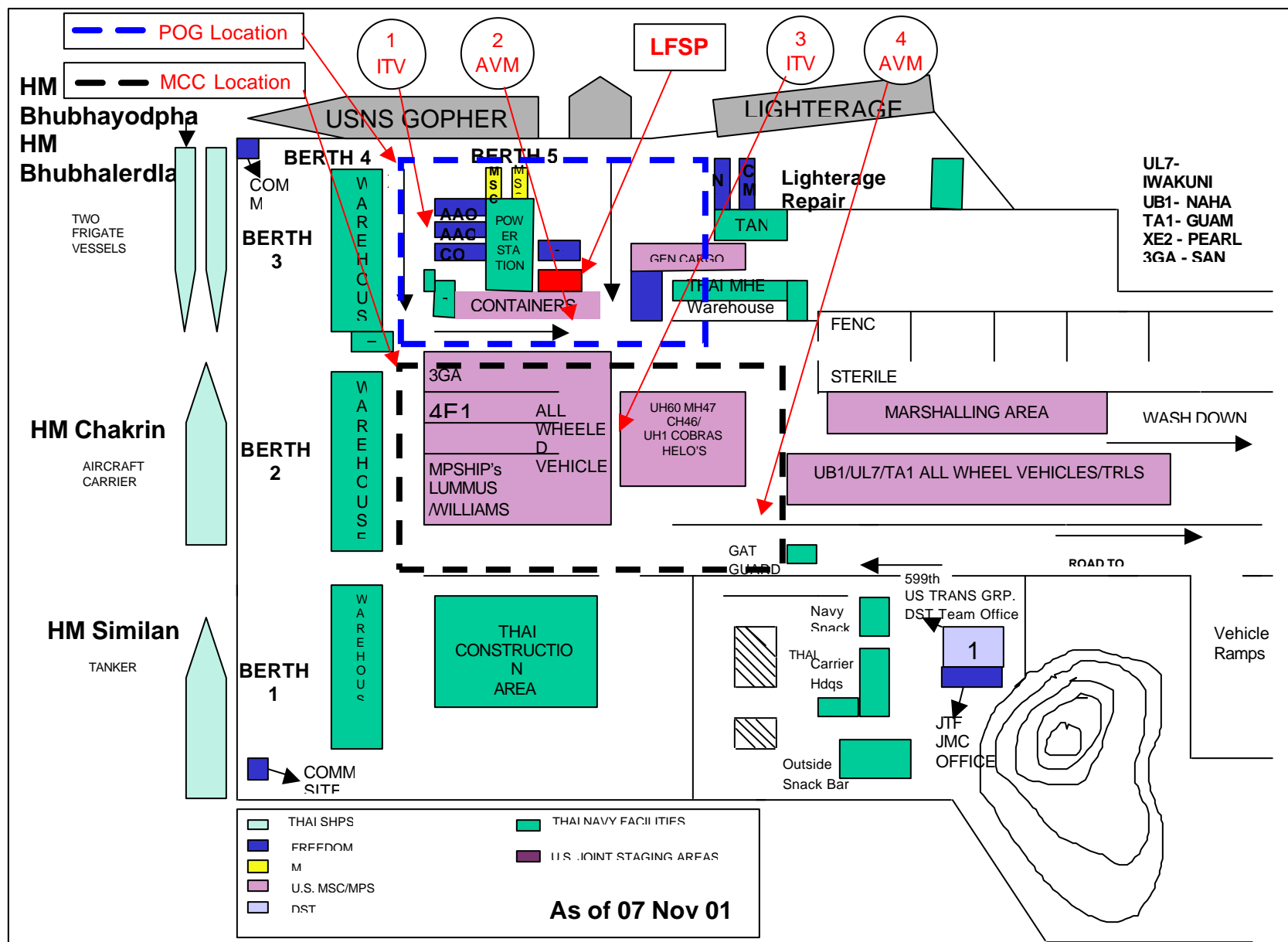

**Figure 4: Chuksamet Port Area Diagram
As-Tested Reader Locations**

1.3.2 MCC

After leaving the POG, the equipment moved into the MCC. At the MCC, the equipment was organized by the AAOE to which it would be convoyed. One fixed reader (Location 4 in Figure 4) was set up at the exit to the MCC to capture data for the AVM. One fixed reader (Location 3 in Figure 4) at the MCC captured data for the ITV server. Refer to the Unisys After Action Report in Appendix A2 for more detailed information on the ITV system.

The Marine Corps used the same barcode scanning process that was used at eh POG to capture visibility of the equipment exiting from the MCC.

1.3.3 LFSP

The LFSP was the central point at which all RFID data converged. The data from all RFID readers was transmitted wirelessly to this location. This included data streaming in over the Marine Corps network from the RFID readers capturing data at the AAOEs. The RFID data was posted to both the AVM computer and ITV server. The AVM website was available to users on the Marine Corps network. The ITV website was accessible on the internet.

Network monitoring software was installed on the RFID computers at the LFSP and AAOE. This software allowed data packet traffic to be monitored and captured during the experiment. This data was analyzed and is presented in Section 5 of this report.

1.4 Samaesan

The AAOEs were located at Samaesan, which is located approximately 20 minutes by vehicle away from the port. This location was much closer than was originally planned. One gate interrogator and one fixed reader were installed at the AAOEs. The gate interrogator captured data for the AVM. This data represented visibility of the equipment arriving at the AAOEs. The fixed reader captured data for the Army ITV site.

Barcode scanning operations will be conducted by the Marine Corps at each AAOE. Barcode scanning information is periodically uploaded to a computer at the AAOE that is running MDSS II. Pen and logbooks will be used as a backup to the barcode scanners.

Appendix B2: System Setup and Operation

This appendix discusses all the equipment that was used during this experiment. The discussion includes component descriptions, system descriptions and operational instruction. Diagrams are included where appropriate to provide system descriptions for hardware and data communications. The differences between the planned and as-tested configurations of the equipment is identified and discussed in the appropriate sections.

There are five subsections related to the equipment and operation. One subsection provides an overview of the system configuration. The other four subsections discuss the four technologies used during the experiment. These four subsections are: RFID System, Asset Viewer Manager, Iridium and Network Monitoring.

1. System Overview

Figures 4 through 6 below provide a graphical description of the system architectures that were planned for use during the experiment. Figure 4 describes the overall architecture for the experiment. The equipment flow and data flow is shown in this diagram. Figures 5 and 6 show in more detail the network architecture that was utilized for presenting the TAV information to users. These figures are based on the Operations Order for Cobra Gold⁴.

⁴ Cobra Gold 2002 Operations Order 01-02; Annex K, Appendix 7.

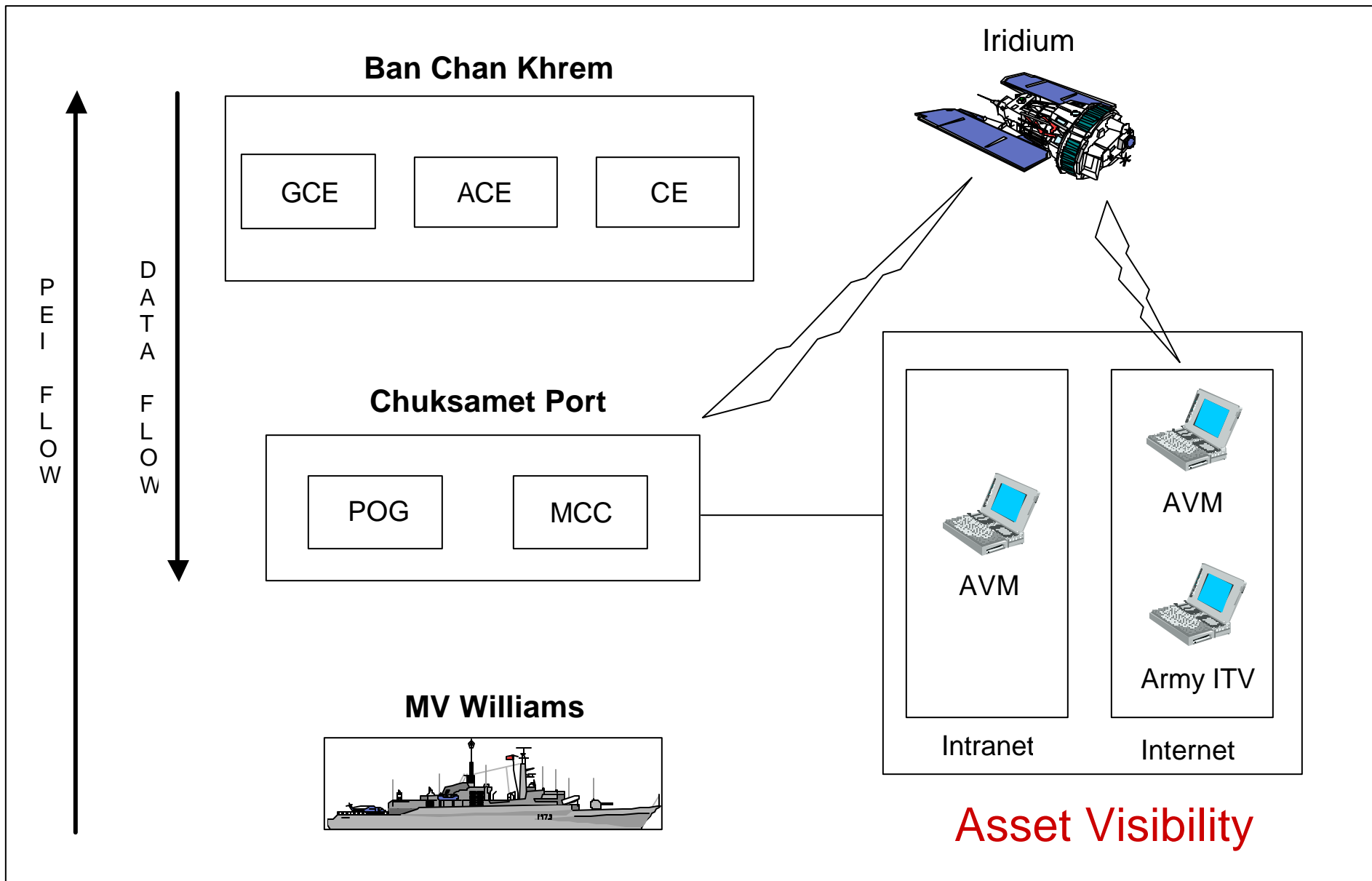

Figure 4: TAV Operational Architecture

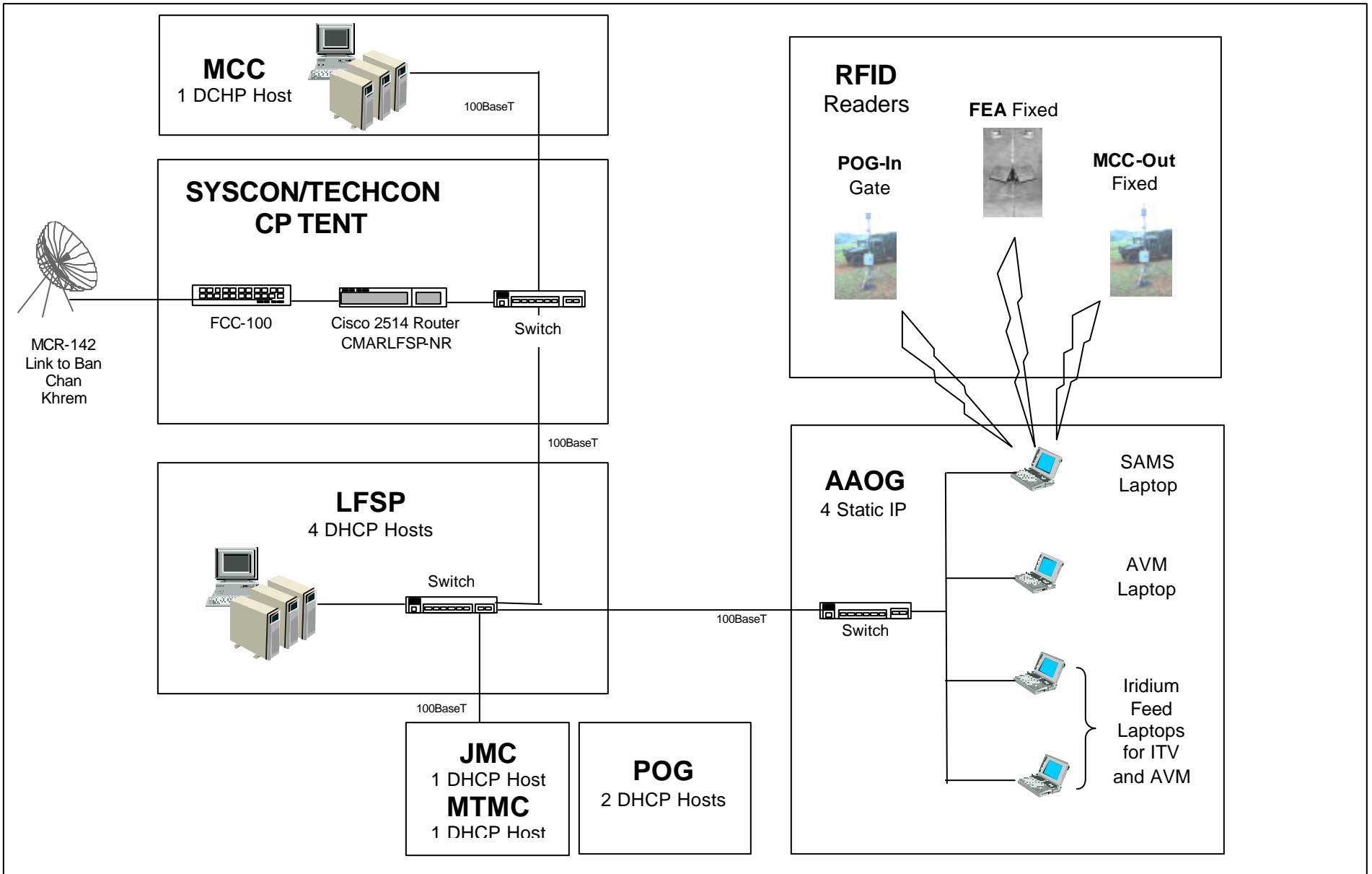

Figure 5: POG/MCC Network Architecture

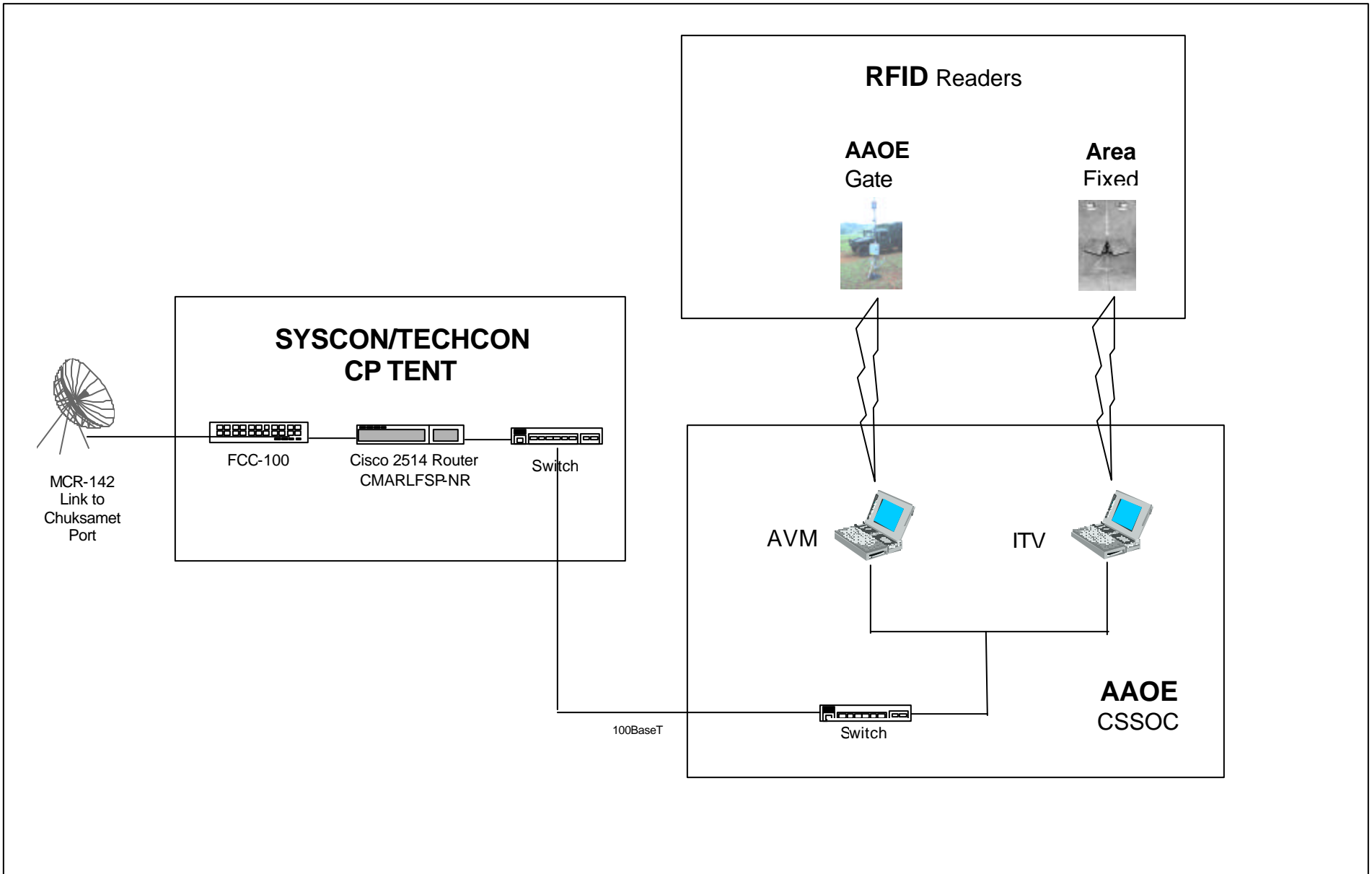

Figure 6: Ban Chan Khrem Network Architecture

2. RFID System

Savi Technologies, Inc manufactures the RFID system used for this experiment. This section describes the general configuration of the RFID system as it was set up for the exercise. Also included are general system operating requirements. Appendix B4 provides descriptions of the components and connections of the RFID system. Additional information and instructions on the set up and operation of the system may be found in the Draft User's Manual for the RFID system⁵.

There are two main components to the system:

1. The RFID hardware provides the capability for capturing the tag data
2. The software that controls the hardware and transmits tag data is called the Savi Asset Manager System (SAMS). SAMS will push tag data files to the Asset Viewer Manager (AVM), which is discussed separately.

These two components are discussed below. The discussion is organized primarily by the locations at which the equipment will be installed.

The software that controlled the RFID system for pushing data to the Army ITV website is discussed in Appendix A2.

Note for the reader: The terms portal reader and GateReader are synonymous in the context of this document. The terms wide area reader and SaviReader are also synonymous in the context of this document.

2.1 RFID Hardware

2.1.1 Tag Preparation and Installation

The SaviTag 410R model was the type of RFID tag used for this experiment. Tag preparation consisted only of performing an operational test on the tags. All tags identified for use were powered on and read by the RFID system to ensure operational integrity. No data was written to the tags. Only the tag identification number that is hard-coded into each tag was used during the experiment.

3D FSSG provided an Equipment Density List for the exercise. The Marine Corps identified 261 PEI from this EDL that were to be equipped with RFID tags. All of these PEI were located on the MV WILLIAMS. Data sheets were produced based on these PEI. An abbreviated data sheet is presented in Appendix C1. While onsite in Thailand, it was determined that the EDL had changed. This resulted in using a different approach than had been planned for applying the tags to the PEI. Instead of using the data sheets that had been prepared as they were, the tag installers tagged a vehicle and then annotated the identification number of that tag on that data sheet.

⁵ [Draft User's Manual for RFID System](#); Developed by SAIC for NFESC; 18 September 2002.

Only the RFID Tag Identification Number and the Serial Number columns were used in the data sheets provided in Appendix C1. Those data sheets were converted to electronic format and are provided in Appendix D1. The completed data sheets indicate that a total of 133 PEI were tagged.

The tags were installed on the PEI using zip ties to attach the tag to the side view mirror of the equipment. Refer to Figure 7 for a representative example of the location at which the tags were applied.



Figure 7: RFID Tag Placement

2.1.2 Frustrated Equipment Area

RFID equipment had been planned for installation at the Frustrated Equipment Area. Due to the shipping delay, this area was not set up.

2.1.3 POG Entrance

The location at which the POG was established is shown in Figure 4. The POG entrance for the RFID system that pushed data to the AVM is shown at location 2 in Figure 4. A GateReader system was setup at the POG entrance to capture all tagged PEIs entering the area. The GateReader system consisted of the following hardware:

- one RF unit (antenna)
- one primary wake-up antenna
- one motion sensor
- one GateReader control panel

The above hardware was mounted on a tripod. This GateReader configuration was used to track incoming PEI's that were traveling in a single-lane, single-direction into the POG.

A RF Relay 200 system was connected to the GateReader system and mounted on the same tripod. The RF Relay 200 system consisted of the following:

- one 2.4 GHz antenna
- one filter
- one up/down converter
- one RF Relay 200 LonWorks box

The antenna was mounted on the top of the tripod. The RF Relay 200 system transmitted the tag data via a wireless link to a second RF Relay 200 system located at the LFSP. The second RF Relay 200 system was mounted on the top of a separate tripod and was connected through LonWorks network protocol to a laptop PC running SAMS. This computer will be connected to the Marine Corps network. The transmit and receive channels on both RF Relay 200 systems were set to 100. The tag data was then be sent over the network to the AVM in the LFSP.

The GateReader system, RF Relay 200 systems and laptop will use 110V A/C power.

The ITV server was populated using a fixed reader. The location of this reader is shown at location 1 in Figure 4. The setup for this reader is discussed in Appendix A2.

2.1.4 MCC Exit

The location at which the MCC was established is shown in Figure 4. The MCC exit for the RFID system that pushed data to the AVM is shown at location 4 in Figure 4. A fixed reader was located at the exit to the MCC to capture all tagged PEIs exiting the area.

The main components of this system were:

- one Savi Reader
- two RF Links

The reader and one link were mounted on a tripod at the MCC exit. The reader collected tag data and transmitted this data by wire to the link. This link transmitted the tag data wirelessly to the second link. The second Link was mounted on a horizontal, metal arm attached to the top of a separate tripod and was connected through RS-485/RS-232 network protocol to a laptop PC running SAMS. The PC was connected to the Marine Corps network. SAMS then pushed tag data files over the network to the Asset Viewer Manager (AVM) PC located at the LFSP. The transmit and receive channels on both links was set to the same channel.

Savi Solar Power Modules powered the reader and links. The laptops used 110V A/C power.

The ITV server was populated using a fixed reader at the MCC. The location of this reader is shown at location 3 in Figure 4. The setup for this reader is discussed in Appendix A2.

2.1.5 AAOE

Two readers were set up at the AAOE, one a gate reader and the other a fixed reader. The gate reader collected tag data to populate the AVM. The fixed reader collected tag data and populated the ITV server.

The gate reader collected tag data and provided it to a SAMS computer at the AAOE. This computer was connected to the Marine Corps network. The network at the AAOE was connected to the network at the POC using an MCR 142 radio link. The tag data was pushed to the AVM computer at the LFSP using this link. Refer to Figures 5 and 6 for this configuration. The gate reader setup was identical to that used at the POG.

The fixed reader setup was the same as that used for the fixed reader used at the MCC and POG for tag data population of the ITV server. This setup is discussed in Appendix A2.

2.1 Savi Asset Manager System Setup

Savi Asset Manager System (SAMS) version 2.1.1 software was installed on two laptops for this experiment. The software consists of the SAMS Server and SAMS Client. These laptops received tag data collected by the Savi RFID equipment. The laptops were connected to the Marine Corps network. RFID data streaming into SAMS was sent to the AVM by FTP.

One SAMS laptop was located at the LFSP. This laptop used the RF Relay 200 system and the Savi Link at the LFSP to capture the tag data collected by the readers at the POG entrance and MCC exit.

The second SAMS laptop was located at the AAOEs. This laptop captured data being collected by the GateReader located at the entrance to the AAOEs.

Refer to the Draft User's Manual for the RFID system⁵ for specific information on the operation of SAMS.

The fixed readers collecting tag data for population of the ITV server were running software called TIPS. This software is discussed in Appendix A2.

3. Asset Viewer Manager (AVM)

One laptop was dedicated to run the AVM. This laptop was connected to the Marine Corps network. This laptop received tag data files from the SAMS computers connected to that same network. This configuration allowed Marines connected to the network visibility of the AVM.

The AVM consists of four software modules. Each module provides a critical function in the process of transforming the tag data generated and captured by the RFID hardware into information for the end user. The AVM laptop runs on Windows NT Server, Service Pack 4. The four modules and their functions are described below.

Refer to the Draft User's Manual for the RFID system⁵ for specific information on the operation of AVM.

3.1 SAMS Client Agent Transfer (SCAT)

The SCAT module detects files sent to the AVM laptop from the SAMS laptops. Upon detecting these files, SCAT pushes the data into the AVM database. The operation of SCAT is autonomous. No user action is required.

3.2 AVM Database

The AVM database is an Oracle relational database. This database contains the data that was obtained from the EDL for the exercise. The associations between the EDL and the RFID tags were made in this database. All of the tag data files produced

by the RFID system were imported into this database by SCAT. All user actions required to load, modify and administer the database were performed through the AVM Graphical User Interface.

3.3 Webserver

The Webserver served the purpose of posting the information generated within the AVM database to a website. This website was hosted on the Marine Corps network. The end user interested in the progress of the MPF operation could access that information through this website.

3.4 MDSS II Import/Export (MIE)

The MIE allows the AVM database to interchange data with MDSS II. This interface occurs under two situations. The first is when a final EDL has been generated for an exercise/operation. This file is exported from MDSS II as a data file with a 'pex' extension. This file is imported to the AVM database via the MDSS II interface. Once tags have been associated with PEI from the EDL within the AVM database, the RFID tag data files being imported through SCAT to the AVM database can be associated together. This data is compiled within the AVM database. The result is a file with current AIT LOCATION fields exported to MDSS II. This allows MDSS II to be updated on an as needed basis with the near real time data acquired by the RFID system.

The MIE functionality was not used for this experiment. The module was designed to function with MDSS II Version 6.0. MDSS II Version 6.2 was used during CG 02. Validation and verification of the module could not be completed prior to the experiment.

4. Iridium Satellite Link

The Department of Defense has purchased the Iridium satellite network and provided access to the armed services for data transmission. Headquarters Marine Corps has been developing equipment for the purposes of utilizing this satellite communications capability. Some of this equipment was provided for use during this experiment.

The system was not operational during the experiment. Challenges were experienced when attempting to transmit the data using the modem while Windows software was operating. A discussion on the Iridium issues is provided in Appendix A3. The planned use of this equipment is described here:

An Iridium modem and antenna will be used to transmit RFID data from Chuksamet Port to an Iridium gateway located in Hawaii. This gateway will have connectivity to the internet. With this connection, two capabilities will be added to the experiment. One will be accessibility to the AVM website by internet users worldwide. The other will be an RFID data transmission stream being sent to the Army ITV server in Korea. This data will be posted to the server. The data will be visible to users having

access to that ITV server. The hardware being used to establish this satellite connection is described in Appendix B4.

The impact of the failure to establish the satellite data link was mitigated by the fact that the network established by the Marine Corps had internet connectivity. The ITV server was populated using this connection means. The AVM was visible only to those on the network.

5. Network Monitoring

The network architectures used to transport the RFID data were set up essentially as planned. There were two differences. There were fewer interrogators set up and the Iridium satellites were not used. The architectures are illustrated in Figures 5 and 6. The intranet installed by the Marine Corps did have access to the internet. This allowed the fixed reader data to be posted on the Army's ITV site. The network IP addresses that were assigned to the computers monitored in the experiment are listed in the table below. The computer running TIPS for collecting RFID data and transmitting it to the ITV server was not monitored.

Computer/Location	IP Address
SAMS Laptop/AAOG	199.32.177.183
AVM Laptop/AAOG	199.32.177.182
SAMS Laptop/AAOE	199.32.130.215

Network monitoring was conducted to determine the impact that this TAV technology has on the Marine Corps network established for the exercise. Two network parameters were the focus of this monitoring. The first was the data packet sizes that were transmitted by the RFID system. The second was the speed at which those packets were transmitted over the network.

A commercially available network monitoring software tool was used for this task. The software is called EtherPeek. It is distributed by WildPackets. This software is considered to be among the best in the industry. In its evaluation, PC Magazine awarded EtherPeek 5 stars out of 5 in the 'Traffic Analysis' category. This category "is fundamental to the quality of a product. To evaluate this, we test packet filtering, capturing, and decoding capabilities, as well as the ability to generate packets."⁶

EtherPeek was installed on the AVM computer and the two RFID computers. The software was configured to monitor network transmissions concerning TAV data and information between those computers and any clients.

⁶ Sniff Out Trouble; James Sanders; PC Magazine; May 22, 2001

Appendix B3: Safety and Administrative

1. Safety and Administrative

1.1 Safety

The Cobra Gold 2002 TAV experiment was conducted by 3D FSSG. The Marine Corps experiment coordinators shared overall safety responsibility for the experiment. The equipment that was set up and operated for this experiment provided no additional hazard risk to that of normal Marine Corps operations. The equipment used was designed for use in commercial industry applications. All work performed by the NFESC team was done so in administrative areas. Heavy vehicles were operating in the vicinity. Each team member was alert at all times to minimize any risk presented by these vehicles.

RFID Team personnel were required to observe appropriate procedures and utilize appropriate personal protection equipment (PPE) as directed by the NFESC Safety Office. The minimum PPE required for this experiment was hard hats and safety shoes. All RFID Team personnel were to familiarize themselves with NFESC Instruction 5100.11, The Occupational Safety and Health Program Manual. Copies for inspection were readily available at the NFESC Safety Office.

All safety concerns were to be reported immediately to the local Marine Corps Safety Officer. When arriving onsite, the team familiarized themselves with the location of medical facilities in the area. Should conflicts or the need for clarification have arisen, attempts would have been made to resolve the situation with the local Safety Officer. Should further help have been needed, Ms. Robin Skinner at the NFESC Safety Office, (805) 982-1136 or DSN 551-1136, would have been contacted.

1.2 Training

One of the objectives of this effort was to provide 3D FSSG with a residual from the TAV experiment. This residual will allow them to become more familiar with the benefit that can be provided by the technology. To support this residual, key personnel were trained on the setup and operation of the system. NFESC and their support contractors provided this training. Part of this training was provided at CSSG 3 at Marine Corps Base Hawaii prior to the experiment. Additional training was provided to personnel attached to the BSSG and MEB staff during the experiment.

1.3 Roles and Responsibilities

This section discusses the personnel that were involved with the experiment. The table below lists the personnel and their responsibility.

Personnel	Organization	Role/Responsibility
CWO2 Paul E. Major	USMC – 3D FSSG	Experiment Director

Daniel J. McCambridge Robert Johnston	NFESC	Technical Directors
Gladis G. Aispuro	NFESC	System Engineer
Jessica K. Hiraoka	NFESC	System Engineer
Richard Webster	NFESC	System Technician
Jonathan D. Geithner	CNA	Analysis and Evaluation
John Bower	SAIC	Iridium/AVM Support
Peter James	SAIC	MPF Doctrine/Process Expert
Wendell Moon	Unisys	Iridium/Army ITV Interface
SSgt Jerald Cleveland	BSSG-3	Port Operation Group Director
Capt Raul Salcido	BSSG-3	USMC Network Administrator
Capt Carl Davis	JTF	CG-02 Inland Coordinator

Roles and Responsibilities

Appendix B4

RFID and Iridium System/ Component Description & Connections

RFID Hardware

Savi GateReader System

Control Panel

- The control panel contains the microprocessor that controls and provides power to all the GateReader components. It also provides the LonWorks connection between the system and either a computer or a RF Relay 200 system.

Primary Wake-up Antenna

- The wake-up antenna sends a 2.44 GHz wakeup signal from 20 to 50 feet away to the tag causing the tag to become active. In turn, the tag will transmit a 433 MHz signal at a range of approximately 200 feet that is received by the RF Unit.

Motion Sensor

- Approaching objects activates the motion sensor. It operates at 10.525 GHz (+/- 25MHz) using a microprocessor-analyzed Doppler microwave for its detection method. Once activated, it triggers the activation of the wake-up antenna. *This information can be found in TC-26B Vehicle Detector Installation Instructions, p.2.*

RF Unit

- The RF Unit is an antenna that transmits and receives a 433 MHz RF signal. This component receives information from tags traveling up to 25-MPH and transmits the information to the GateReader control panel.

Technical specification information listed above can be found in Savi GateReader 410R Installation Guide, Version 1.0, pages 1-3 to 1-5 (unless otherwise noted).

Savi RF Relay 200

RF Relay 200 LonWorks Box

- The RF Relay 200 LonWorks box contains a LongRanger 2000 RF modem and a LonWorks router. The modem is a spread spectrum modem that transmits and receives a 2.4 GHz signal. This component provides the LonWorks network protocol connection to either a GateReader or a computer. *Technical specification information found in Savi RF Relay Installation Guide, Version 1.0, pages 1-3 to 1-4.*

RFID Hardware

Omni-directional Antenna

- The RF Relay 200 uses a Mobile Mark, Inc. OD9-2400 omni-directional antenna. This 9-dBi antenna transmits and receives in the 2.4 to 2.485 GHz frequency range and has a 14-degree vertical beamwidth. Its range is up to 7500 feet. *Information found in the Mobile Mark, Inc. Product Specifications for OD Series Omni Antenna.*

Filter

- The RF Relay 200 system uses a Model NLP-2950 filter manufactured by Mini-Circuits. This filter functions with a passband of 2.7 GHz. *Information found in the Mini-Circuits 12.5 to 3000 MHz Specification Sheet.*

Up/Down Converter

- The up/down converter, model number UD2.4B-0C, takes the 2.4 GHz signal received by the antenna and down converts it to a 900 MHz signal for the modem. It also takes the 900 MHz signal from the modem and up converts it to 2.4 GHz to be transmitted out the antenna. The up/down converter operates in the 2.450 to 2.475 GHz frequency range. *Information found in UtiliCom Operator's Manual LongRanger 2020 Spread Spectrum Modem, Models ISM2.4-1C64 and ISM2.4-4C97.*

Savi Reader

The Savi Reader is a 433 MHz antenna used to transmit and receive tag information up to 200 feet away. It can be directly connected to a computer using RS-485/RS-232 network protocol. The Reader can also be connected via a wireless system using at least two RF Links.

RF Link

The Savi RF Link is a 433 MHz antenna used to transmit and receive information from a Savi Reader or another RF Link using RS-485/RS-232 network protocol.

SaviTag 410

The SaviTag 410 holds 128 KB of read/write memory. Both the GateReader and the Savi Reader can read the SaviTag. However, the GateReader can pick up 50 KB of information. A lithium battery that can be easily replaced by hand powers the tag and the overall enclosure is a plastic waterproof case that is able to withstand shock and vibration.

RFID Hardware

SaviTag 410 Battery

The SaviTags each contain one Model TL-5903 Lithium Thionyl Chloride AA battery. These batteries have a nominal voltage of 3.6V, nominal capacity of 2.40Ah, and a nominal discharge current of 2.0mA. These batteries provide:

- greater density of up to 710 Wh/Kg and 1300 Wh/l
- higher capacity
- higher operating voltage
- longer life: expected shelf life of 10 years

Battery information was found on Tadiran Lithium Batteries web sight at <http://www.tadiranbat.com/index2.htm>

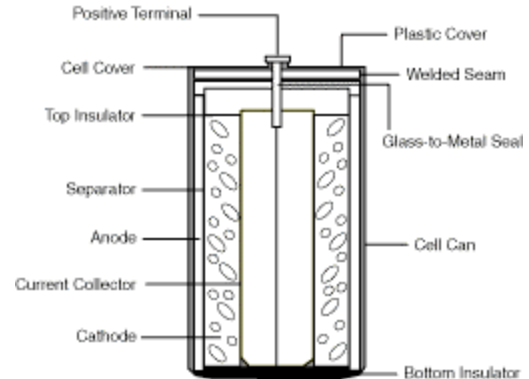

Solar Power Module

The Solar Power Module, Model Number CPA-1100, is able to generate the necessary power to run the Savi Reader and RF Link through the use of sunlight.

Equipment Connections

Primary Wakeup Antenna



Figure 1: Connections – Wakeup Antenna

**Motion Sensor
RFID Hardware**

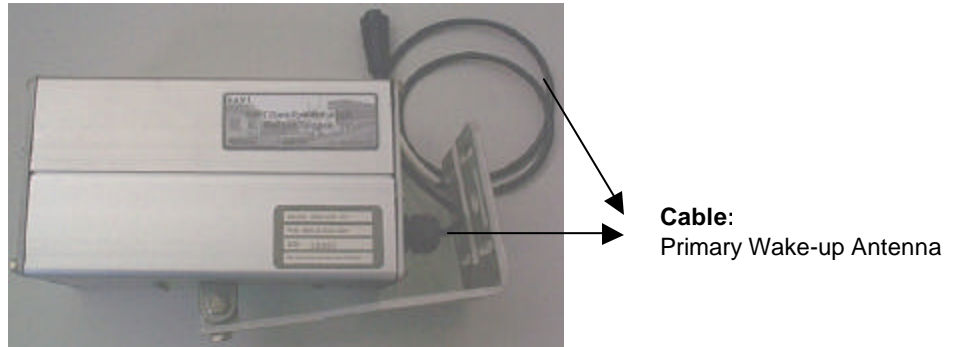

Figure 2: Connections – Motion Sensor

RF Relay 200- LonWorks Box

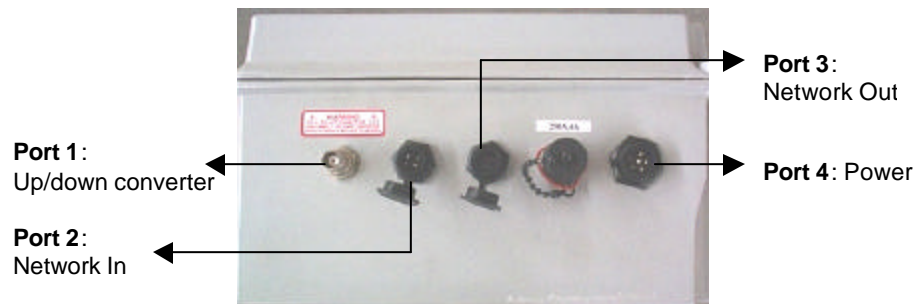

Figure 3: Connections - RF Relay LonWorks Box

RFID Hardware

Gate Reader control panel

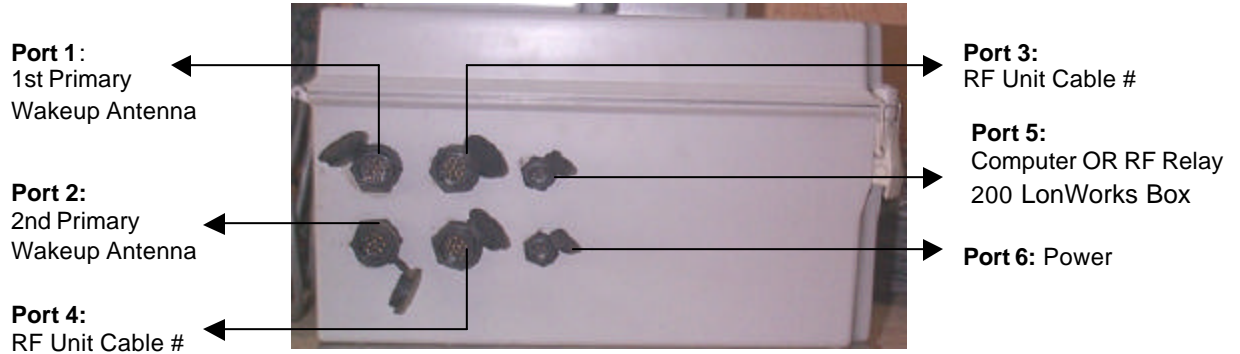

Figure 4: Connections – Gate Reader Control Panel

RF Relay 200- Antenna & Filter

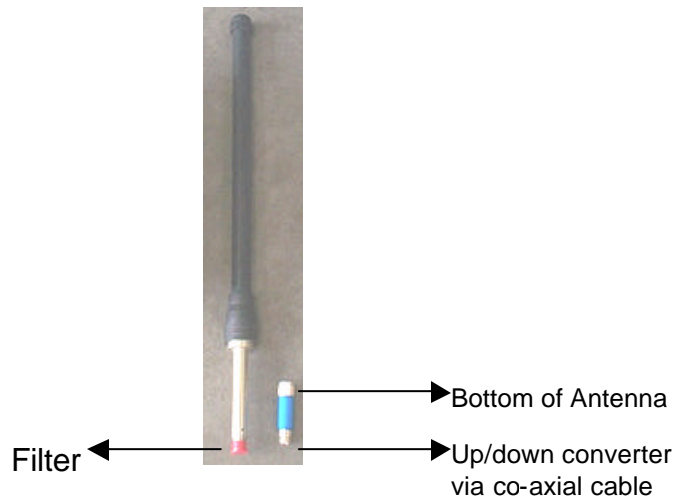

Figure 5: Connections – RF Relay Antenna & Filter

RFID Hardware

Savi Reader & RF Link

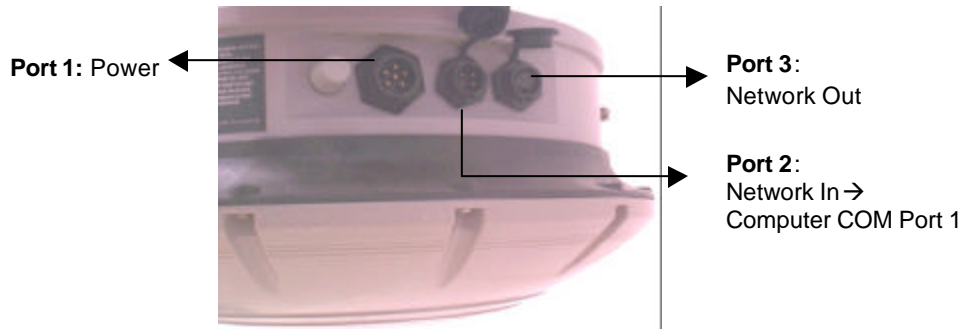

Figure 6: Connections – Savi Reader & RF Link

Solar Power Panel

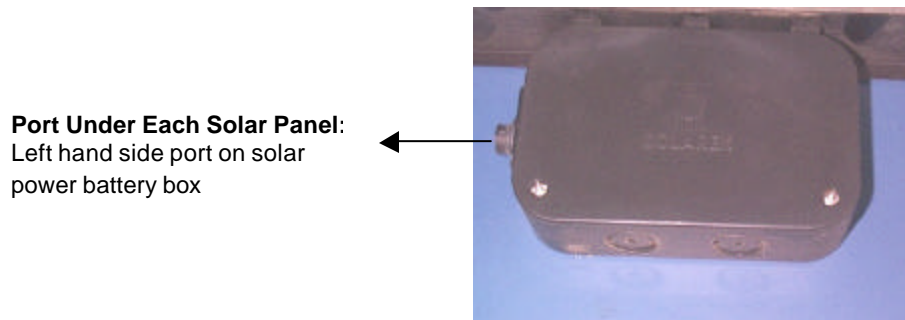

Figure 7: Connections – Solar Power Panel

RFID Hardware

Solar Power Battery Box

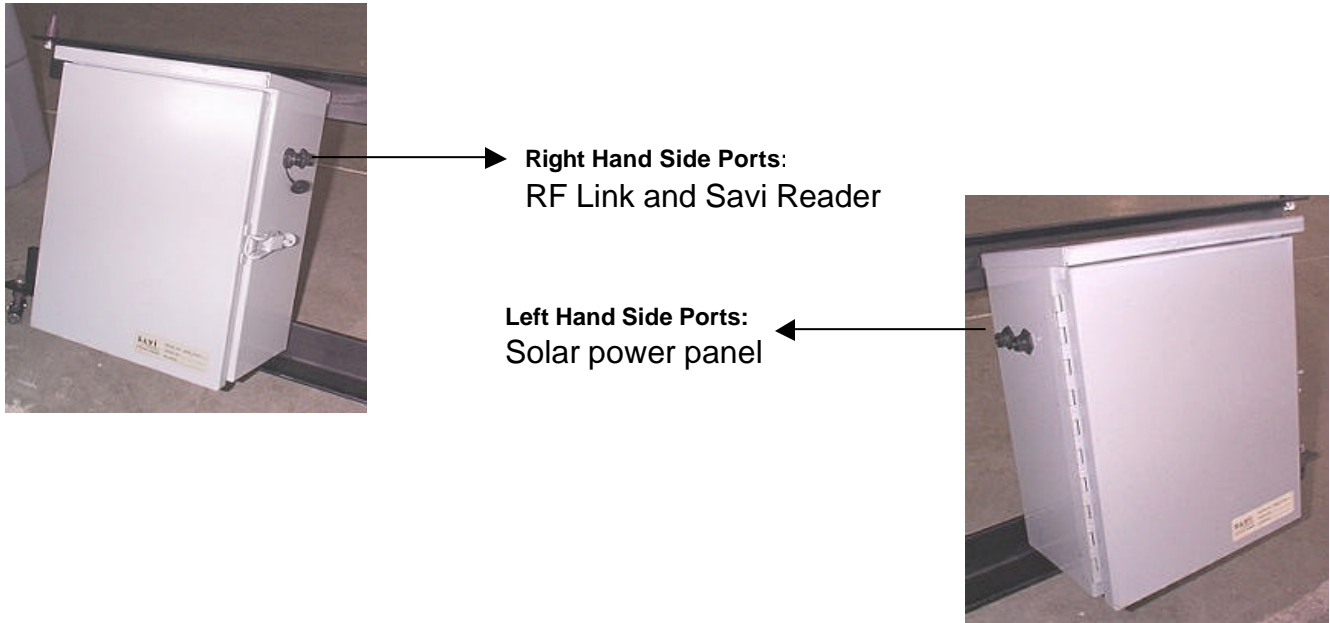

Figure 8: Connections – Solar Power Battery Box

Iridium Hardware and Connections

System Setup

NAL RESEARCH CORPORATION

Atmospheric Sensor Research and Development

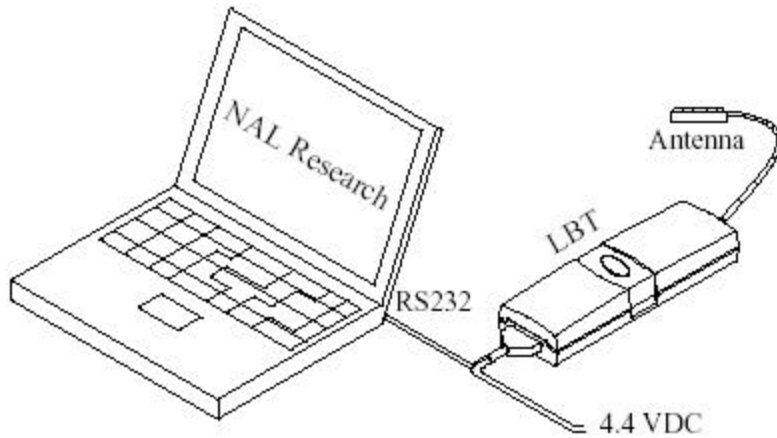
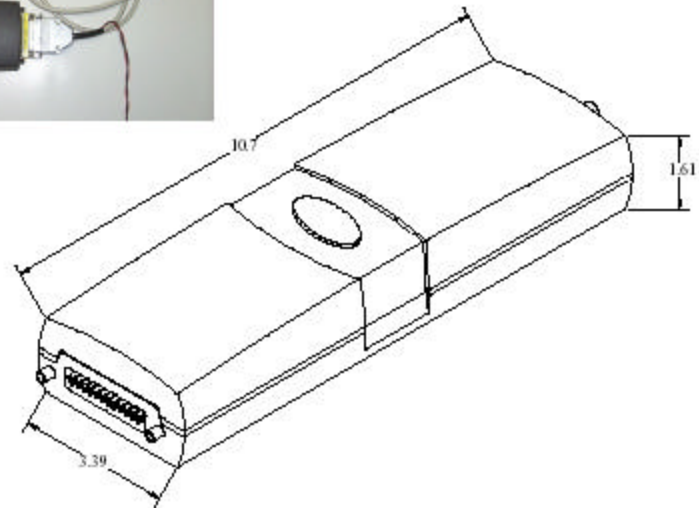

Iridium Hardware and Connections

Configuration Instructions

NAL RESEARCH CORPORATION

Atmospheric Sensor Research and Development

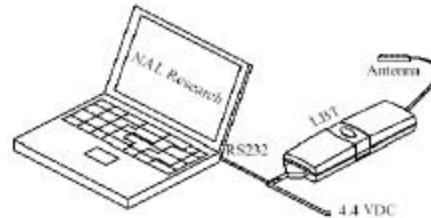

Instructions

- 1) Connect 25-pin connector to the Iridium modem
- 2) Connect antenna
- 3) Connect 9-pin serial port to an external device (computer)
- 4) Supply 4.4VDC (voltage can range from 4.0VDC to 6.0VDC)
- 5) Wait for about 10 seconds for the modem to establish connection with the satellite
- 6) Use Hayes modem commands (included in the package) to communicate between the modem and external device.
- 7) Examples:
 - To make a phone call to a land-line phone execute the following:
ATD 001 + phone number (ATD 0017033925676)
 - To make a phone call to another Iridium modem (or phone) execute the following:
ATD 00 + phone number (ATD 008816310XXXXX)
- 8) Recommended antenna cable types are listed below. Cable of any length can be used, however, make sure the signal loss is no more than 3dB.
 - LMR-195-PVC Coaxial Cable (Time Microwave Systems, 800-867-2629, <http://www.timesmicrowave.com>)
 - LMR-240 Coaxial Cable (Times Microwave Systems)
 - Andrew C2FP Coaxial Cable RG-8/U
 - Coaxial Cable RG-6 (Radio Shack)

Iridium Hardware and Connections

Internal View of Components

Only a single DC power source (ranging from 4.0VDC to 6.5VDC) is required through this connector

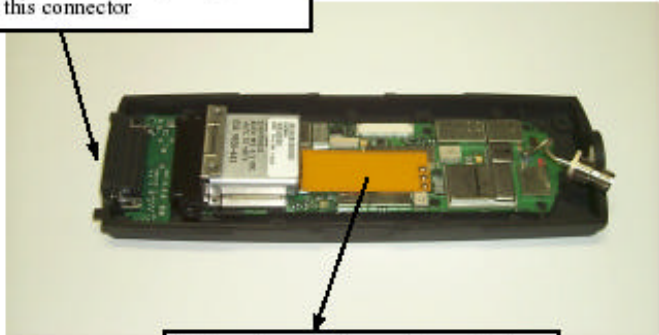

SIM card reader is mounted under the L-Band transceiver inside the case

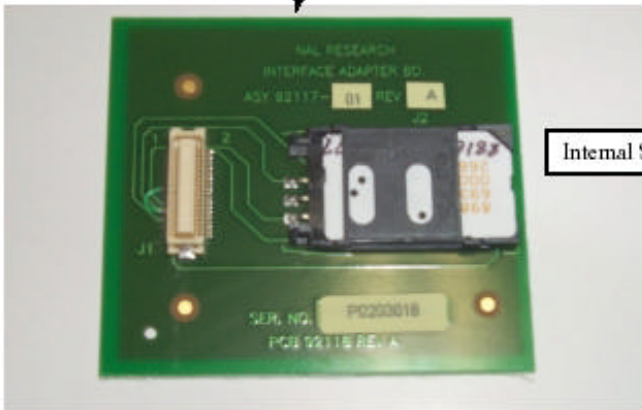
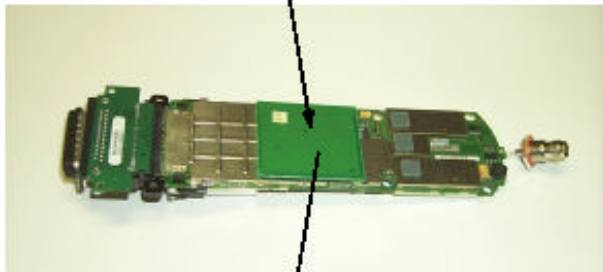

Internal SIM card reader

Iridium Hardware and Connections

Specifications

RS-232 Data Port Connector, 9-PIN D-SUB

PIN #	SIGNAL	DESCRIPTION
1	DCD	Data carrier detect
2	S_RX	Data receive
3	S_TX	Data transmit
4	DTR	Data terminal ready
5	SIGNAL GND	Ground
6	DSR	Data set ready
7	RTS	Request to send
8	CTS	Clear to send
9	RI	Ring indicator

DC Power

WIRE	SIGNAL	DESCRIPTION
BLK	SIGNAL GND	Ground
RED	4.0 to 6.5VDC	DC Voltage

Specifications:

Weight: 1.6 pounds
Dimensions: 10.7" L x 3.4" W x 1.6" D
SIM Card Reader: Internal
Operating Frequency: 1616 – 1626.5MHz
Operating Temperature: -30°C/+60°C
Duplexing Method: Time Division Duplex
Multiplexing Method: TDMA/FDMA
Link Margin (w/ external antenna): 12.5 dB average

Appendix C

Data Collection

Appendix C1: Data Collection Procedure

Appendix C2: List of PEI to be Tagged

Appendix C3: Offload Process Observation

Appendix C1: Data Collection Procedure

1. General

There are two areas in which data was collected: 1) RFID system data transmission/network monitoring and 2) the use of organic AIT and RFID equipment used to track equipment during the MPF offload process.

This section consists of three areas. The first focuses on the data collection requirements for the use of the organic AIT used to track equipment during the MPF offload process. The second identifies the data collection requirements for the RF ID network bandwidth parameters. The third addresses the network monitoring parameters.

All data collected was recorded on the data sheets included in Appendix C2 with the exception of the network monitoring data. That data was collected in electronic form. A selection of the completed data sheets is included in Appendices D1 and D2. Graphical representation of the network data is presented in Appendix D3. All data collected during the experiment can be obtained upon request from the Naval Facilities Engineering Service Center (Point of Contact is Daniel J. McCambridge, 805-982-1296, DSN 551-1296, mccambridgedj@nfesc.navy.mil).

During all operations, the following items were to be observed and recorded when applicable:

- Number of personnel required to perform specific tasks
- Amount of time required to perform specific tasks
- Hardware failures or problems
- Software failures or problems
- Unexpected events - narrative descriptions
- Methods used by personnel to collect data
- Methods used to transmit data
- Results of data reconciliation
- Frequency of data reporting

2. Organic Marine Corps AIT Operations

Barcode scanning operations occurred at the POG, MCC and AAOEs. The following data was to be captured at these locations.

- Indicate the number of personnel required to perform the barcoding operation. Describe the actions of each person.
- Describe the process by which the data from the barcode scanners is transferred to the MDSS II computer. Measure and record the time required for this data transfer to occur.

- Discuss how the reconciliation process is performed to match the equipment being barcode scanned at this location with the last time it was scanned.
- Record the number of times that the barcode scanner is required to be docked.
- Document the process used to track individual PEI, i.e. if trying to locate a misplaced or lost item. Measure and record the time required for this process. Requesting the Marines to locate a specific PEI may facilitate this.
- Describe the process used to forward reconciled MDSS II files to the next scanning point. Also document how that file is handled and used at that next point.
- Identify the highest level at which data is reconciled and describe how that data is utilized to support both logistical and operational requirements.

3. RFID System Operations

RFID readers were set up at or near the barcode scanning locations. The following data was to be captured at these reader locations.

- Indicate the number of personnel required to monitor the reader location. Describe the actions of each person.
- Describe the process by which the data from the RFID tags is transferred to the AVM. Measure and record the time, for approximately 10 RFID tags per day of operation, required for this data transfer to occur.
- Discuss how the reconciliation process is performed using the MDSS II export function of the AVM.
- Document the process used to track individual PEI, i.e. if trying to locate a misplaced or lost item. Measure and record the time required for this process. Requesting the Marines to locate a specific PEI may facilitate this.
- Identify the highest level at which data is reconciled and describe how that data is utilized to support both logistical and operational requirements.

4. Network Monitoring

The network monitoring process was autonomous. Data was captured by the software and logged on the computer. These logs were retrieved following the experiment for reduction and analysis.

Appendix C2: List of PEI to be Tagged (abbreviated)

RFID Tag Number	Item Id	Serial Number	Description	Qty	
	A1935		RADIO AN/wMRC138	10	1
	A1935		RADIO AN/wMRC138		10
	A1955		RADIO TERM SET MRC142	2	1
	A1955		RADIO TERM SET MRC142		2
	B0391		RTCH 50000LB	2	1
	B0391		RTCH 50000LB		2
	B0443		CRANE 25T	2	1
	B0443		CRANE 25T		2
	B0589		M9 ARMORED COMBAT EX	1	1
	B2460		MC1150 TRACTOR	2	1
	B2460		MC1150 TRACTOR		2
	B2462		D7G CATEPILLAR	4	1
	B2462		D7G CATEPILLAR		4
	B2482		TRACTOR AWD	1	1
	B2567		TRACTOR RT 10K	7	1
	B2567		TRACTOR RT 10K		7
	D0085		CHASSIS TRLR M116	6	1
	D0085		CHASSIS TRLR M116		6
	D0209		LVS MK48	19	1
	D0209		LVS MK48		19
	E0665		HOWITZER M198	6	1
	E0665		HOWITZER M198		6
	E0846		AAVP7A1	9	1
	E0846		AAVP7A1		9
	E1888		TANK COMBAT M1A	2	1
	E1888		TANK COMBAT M1A		2
Total PEI				261	--

Appendix C2: Offload Process Observation

Daily Log Sheets

Instructions:

This log shall be filled out on a daily basis. General narratives of the tasks being performed shall be recorded. All remarks shall be annotated with the specific paragraph of this document to which they apply. Refer to Appendix C1 for information on what types of data are to be collected.

Date: _____

Location: _____

Objective: _____

Remarks:

Data Logger Printed Name: _____

Organic Marine Corps AIT Operations

POG

1. Record the number of personnel required to perform barcoding operations:
2. Describe the actions of barcode scanners – include any use of pen and logbook:
3. Describe the process by which the data from the barcode scanners is transferred to the MDSS II computer. Measure and record the time required for this data transfer to occur.
4. Describe the process used to forward reconciled MDSS II files to the next scanning point. Also document how that file is handled and used at that next point.
5. Record the number of times that the barcode scanner is required to be docked at a docking station. Record the number of scans that the barcode scanner captured.
6. Discuss how the reconciliation process is performed at this location. The process is performed to compare the inventory of equipment established as arriving at this location using the barcode scanners with the inventory of equipment established at the previous location. Include in this discussion, the time required for the reconciliation, any discrepancies identified and how these were solved.

Date:

MCC

1. Record the number of personnel required to perform barcoding operations:
2. Describe the actions of barcode scanners – include any use of pen and logbook:
3. Describe the process by which the data from the barcode scanners is transferred to the MDSS II computer. Measure and record the time required for this data transfer to occur.
4. Describe the process used to forward reconciled MDSS II files to the next scanning point. Also document how that file is handled and used at that next point.
5. Record the number of times that the barcode scanner is required to be docked at a docking station. Record the number of scans that the barcode scanner captured.
6. Discuss how the reconciliation process is performed at this location. The process is performed to compare the inventory of equipment established as arriving at this location using the barcode scanners with the inventory of equipment established at the previous location. Include in this discussion, the time required for the reconciliation, any discrepancies identified and how these were solved.
7. Request the Marines to identify the location of one PEI. Describe the process used to locate the PEI. Include in this discussion, the time required to locate the PEI and the number of personnel involved in the process.

Date:

AAOE – ACE

1. Record the number of personnel required to perform barcoding operations:
2. Describe the actions of barcode scanners – include any use of pen and logbook:
3. Describe the process by which the data from the barcode scanners is transferred to the MDSS II computer. Measure and record the time required for this data transfer to occur.
4. Describe the process used to forward reconciled MDSS II files to the next scanning point. Also document how that file is handled and used at that next point.
5. Record the number of times that the barcode scanner is required to be docked at a docking station. Record the number of scans that the barcode scanner captured.
6. Discuss how the reconciliation process is performed at this location. The process is performed to compare the inventory of equipment established as arriving at this location using the barcode scanners with the inventory of equipment established at the previous location. Include in this discussion, the time required for the reconciliation, any discrepancies identified and how these were solved.

Date:

AAOE – GCE

1. Record the number of personnel required to perform barcoding operations:
2. Describe the actions of barcode scanners – include any use of pen and logbook:
3. Describe the process by which the data from the barcode scanners is transferred to the MDSS II computer. Measure and record the time required for this data transfer to occur.
4. Describe the process used to forward reconciled MDSS II files to the next scanning point. Also document how that file is handled and used at that next point.
5. Record the number of times that the barcode scanner is required to be docked at a docking station. Record the number of scans that the barcode scanner captured.
6. Discuss how the reconciliation process is performed at this location. The process is performed to compare the inventory of equipment established as arriving at this location using the barcode scanners with the inventory of equipment established at the previous location. Include in this discussion, the time required for the reconciliation, any discrepancies identified and how these were solved.
7. Request the Marines to identify the location of one PEI. Describe the process used to locate the PEI. Include in this discussion, the time required to locate the PEI and the number of personnel involved in the process.

Date:

AAOE – CE

1. Record the number of personnel required to perform barcoding operations:

2. Describe the actions of barcode scanners – include any use of pen and logbook:

3. Describe the process by which the data from the barcode scanners is transferred to the MDSS II computer. Measure and record the time required for this data transfer to occur.

4. Describe the process used to forward reconciled MDSS II files to the next scanning point. Also document how that file is handled and used at that next point.

5. Record the number of times that the barcode scanner is required to be docked at a docking station. Record the number of scans that the barcode scanner captured.

6. Discuss how the reconciliation process is performed at this location. The process is performed to compare the inventory of equipment established as arriving at this location using the barcode scanners with the inventory of equipment established at the previous location. Include in this discussion, the time required for the reconciliation, any discrepancies identified and how these were solved.

Date:

6.1.2 RFID System Operations

POG

1. Indicate the number of personnel required to monitor the reader location. Describe the actions of each person.
2. Measure and record the time between the moment the gate reader acquires tag data and the moment that that data is posted to the AVM. Perform this action for a minimum of 10 RFID tags per day of operation.

MCC

1. Indicate the number of personnel required to monitor the reader location. Describe the actions of each person.
2. Measure and record the time between the moment the gate reader acquires tag data and the moment that that data is posted to the AVM. Perform this action for a minimum of 10 RFID tags per day of operation.
3. Request the Marines to identify the location of one PEI. Describe the process used to locate the PEI. Include in this discussion, the time required to locate the PEI and the number of personnel involved in the process.

Date:

AAOE – ACE

1. Indicate the number of personnel required to monitor the reader location. Describe the actions of each person.
2. Measure and record the time between the moment the gate reader acquires tag data and the moment that that data is posted to the AVM. Perform this action for a minimum of 10 RFID tags per day of operation.

AAOE – GCE

1. Indicate the number of personnel required to monitor the reader location. Describe the actions of each person.
2. Measure and record the time between the moment the gate reader acquires tag data and the moment that that data is posted to the AVM. Perform this action for a minimum of 10 RFID tags per day of operation.
3. Request the Marines to identify the location of one PEI. Describe the process used to locate the PEI. Include in this discussion, the time required to locate the PEI and the number of personnel involved in the process.

Date:

Appendix D

Raw & Reduced Data

- Appendix D1: List of PEI Tagged for Offload
- Appendix D2: Selection of Completed Data Sheets
- Appendix D3: Network Analysis Data
- Appendix D4: AVM and Army ITV Screen Shots

Item	TAG ID	S/N	NSN	TAM/DODIC	DESCRIPTION	TAG ID-To-PEI Association Basis
1	106516	554456				data sheets recorded during tagging of PEI shipboard
2	106523	581129	2320011077155	D1158	TRUCK CARGO 5T W/W ISO	Asset Viewer Manager database
3	106525	581124	2320011077155	D1158	TRUCK CARGO 5T W/W ISO	Asset Viewer Manager database
4	106527	552485	2320011077155	D1158	POWER UNIT 12 1/2 TON	Asset Viewer Manager database
5	106531	581093	2320011077155	D1158	TRUCK CARGO 5T W/W ISO	Asset Viewer Manager database
6	106533	522967	2350010818138	E0846	SPEECH SECURITY EQP HALF-DUP W-B TACT AIRBORNE	Asset Viewer Manager database
7	106534	581935	2320011467189	D1159	TRUCK CARGO 5T W/W ISO	Asset Viewer Manager database
8	106535	582824	2320011077155	D1158	TRK UTIL CARGO TRP C W/W	Asset Viewer Manager database; not on data sheets
9	106536	554587				data sheets recorded during tagging of PEI shipboard
10	106539	523590	2350010818138	E0846	GENERATOR, 3 KW, 60 HZ	Asset Viewer Manager database
11	106540	557523	3805012793635	B2567	TRLR SEMI 5000GL REFUELER	Asset Viewer Manager database
12	107583	581861	2320011467190	D1159	TRUCK CARGO 5T W/W ISO	Asset Viewer Manager database
13	107603	529121	2320011077155	D1158	GENERATOR, 10KW,60HZ	Asset Viewer Manager database
14	107606	554494				data sheets recorded during tagging of PEI shipboard
15	107609	523380	2350010818138	E0846	GENERATOR, 3 KW, 60 HZ	Asset Viewer Manager database
16	107612	535757	2320011077155	D1158	TRAM	Asset Viewer Manager database
17	107613	539178	2320011077155	D1158	CHAS.TRLR GEN.PUR. 3.5TON	Asset Viewer Manager database; not on data sheets
18	107616	581885	2320011467190	D1159	TRUCK CARGO 5T W/W ISO	Asset Viewer Manager database
19	107637	582843	2320011077155	D1158	TRK UTIL CARGO TRP C W/W HMMV	Asset Viewer Manager database
20	107771	536048				data sheets recorded during tagging of PEI shipboard
21	107780	529209	2320011077155	D1158	GENERATOR, 10KW,60HZ	Asset Viewer Manager database
22	107793	566011	2410012541667	B2460	TRLR CARGO 1 1/2T 2-WHEEL	Asset Viewer Manager database
23	107795	582840	2320011077155	D1158	TRK UTIL CARGO TRP C W/W	Asset Viewer Manager database
24	108186	581932	2320011467189	D1159	TRUCK CARGO 5T W/W ISO	Asset Viewer Manager database
25	108190	528992	2320011077155	D1158	GENERATOR, 10KW,60HZ	Asset Viewer Manager database
26	108192	582217	2320011077156	D1158	TRK TOW CARRIER, W/SA, W/W	Asset Viewer Manager database
27	108193	545454				data sheets recorded during tagging of PEI shipboard
28	108195	582849	2320011077155	D1158	TRK UTIL CARGO TRP C W/W HMMV	Asset Viewer Manager database
29	108197	582221	2320011077156	D1158	TRUCK, TRACTOR, 6X6 5T	Asset Viewer Manager database
30	108200	539148	2320011077155	D1158	CHAS.TRLR GEN.PUR. 3.5TON	Asset Viewer Manager database
31	108203	522224	2410011551588	B2462	RADIO SET	Asset Viewer Manager database
32	108204	554435				data sheets recorded during tagging of PEI shipboard
33	108205	581139	2320011077155	D1158	TRUCK CARGO 5T W/W ISO	Asset Viewer Manager database
34	108225	582847	2320011077155	D1158	TRK UTIL CARGO TRP C W/FP HMMV	Asset Viewer Manager database
35	108228	568531	3805012793635	B2567	TRAILER, TANK, WATER, 400 GAL, 1 1/2T 2-WHL	Asset Viewer Manager database

Item	TAG ID	S/N	NSN	TAM/DODIC	DESCRIPTION	TAG ID-To-PEI Association Basis
36	108229	582809	2320011077155	D1158	TRK UTIL CARGO TRP C WO/W HMMV	Asset Viewer Manager database
37	108230	568498	3805012793635	B2567	TRAILER, TANK, WATER, 400 GAL, 1 1/2T 2-WHL	Asset Viewer Manager database
38	108239	536890	2320011077155	D1158	ROWPU	Asset Viewer Manager database
39	108240	561325	2320011775167	D0209	TRLR CARGO 1 1/2T 2-WHEEL	Asset Viewer Manager database
40	108247	535591				data sheets recorded during tagging of PEI shipboard
41	108253	539166	2320011077155	D1158	CHAS.TRLR GEN.PUR. 3.5TON	Asset Viewer Manager database
42	108256	531161	2320011077155	D1158	GENERATOR, 60KW,400HZ	Asset Viewer Manager database
43	108258	529081	2320011077155	D1158	GENERATOR, 10KW,60HZ	Asset Viewer Manager database
44	108259	581857	2320011467190	D1159	TRUCK CARGO 5T WO/W ISO	Asset Viewer Manager database
45	108263	561114	2320011775167	D0209	TRLR SEMI LOW BED 40T	Asset Viewer Manager database
46	108264	522603	2350010818138	E0846	RADIO SET	Asset Viewer Manager database
47	108266	582219	2320011077156	D1158	TRK TOW CARRIER, W/SA, WO/W	Asset Viewer Manager database
48	108272	545700				data sheets recorded during tagging of PEI shipboard
49	108286	545740				data sheets recorded during tagging of PEI shipboard
50	108288	522283	2350010809087	E0796	RADIO SET	Asset Viewer Manager database
51	108290	581133	2320011077155	D1158	TRUCK CARGO 5T WO/W ISO	Asset Viewer Manager database
52	108291	582218	2320011077156	D1158	TRK TOW CARRIER, W/SA, WO/W	Asset Viewer Manager database
53	108301	545421				data sheets recorded during tagging of PEI shipboard
54	108302	554480				data sheets recorded during tagging of PEI shipboard
55	108303	582214	2320011077156	D1158	TRUCK FIRE FIGHTING W/C4765	Asset Viewer Manager database
56	108307	581925	2320011467189	D1159	TRUCK CARGO 5T WO/W ISO	Asset Viewer Manager database
57	108310	535486	2320011077155	D1158	TRAM	Asset Viewer Manager database
58	108316	523263	2350010818138	E0846	GENERATOR, 3 KW, 60 HZ	Asset Viewer Manager database
59	108317	551928	2320011467190	D1159	POWER UNIT 12 1/2 TON	Asset Viewer Manager database
60	108318	535864				data sheets recorded during tagging of PEI shipboard
61	108319	581138	2320011077155	D1158	TRUCK CARGO 5T WO/W ISO	Asset Viewer Manager database
62	108325	581948	2320011467189	D1159	TRUCK CARGO 5T WO/W ISO	Asset Viewer Manager database
63	108328	544060	2310011467194	D1002	CHAS.TRLR GEN.PUR. 3.5TON	Asset Viewer Manager database
64	108330	845800				data sheets recorded during tagging of PEI shipboard
65	108341	560752				data sheets recorded during tagging of PEI shipboard
66	108343	523446	2350010818138	E0846	GENERATOR, 3 KW, 60 HZ	Asset Viewer Manager database
67	108344	581843	2320011467190	D1159	TRUCK CARGO 5T WO/W ISO	Asset Viewer Manager database
68	108345	553081	2320011077155	D1158	POWER UNIT 12 1/2 TON	Asset Viewer Manager database
69	108350	551041	2320011775167	D0209	CHAS.TRLR 1TON	Asset Viewer Manager database
70	108351	528920	4210011379943	D1064	GENERATOR, 10KW,60HZ	Asset Viewer Manager database

Item	TAG ID	S/N	NSN	TAM/DODIC	DESCRIPTION	TAG ID-To-PEI Association Basis
71	108352	517359	2320010478756	D1072	RADIO SET	Asset Viewer Manager database
72	108360	539356	2320011775167	D0209	CHAS.TRLR GEN.PUR. 3.5TON	Asset Viewer Manager database
73	108363	525587	2410011551588	B2462	GENERATOR, 10KW,60HZ	Asset Viewer Manager database
74	108364	548405	2420011602754	B2482	CHAS.TRLR GEN.PUR. 3.5TON	Asset Viewer Manager database
75	108365	581153	2320011077155	D1158	TRUCK CARGO 5T W/O/W ISO	Asset Viewer Manager database
76	108366	581140	2320011077155	D1158	TRUCK CARGO 5T W/O/W ISO	Asset Viewer Manager database
77	108367	529199	2320011077155	D1158	GENERATOR, 10KW,60HZ	Asset Viewer Manager database
78	108378	523149	2350010818138	E0846	GENERATOR, 3 KW, 60 HZ	Asset Viewer Manager database
79	108384	522738	2350010818138	E0846	RADIO SET	Asset Viewer Manager database
80	108387	535371	2320011077155	D1158	TRAM	Asset Viewer Manager database
81	108399	560897				data sheets recorded during tagging of PEI shipboard
82	108401	568549	3805012793635	B2567	TRAILER, TANK, WATER, 400 GAL, 1 1/2T 2-WHL	Asset Viewer Manager database
83	108407	552240	2320011077155	D1158	POWER UNIT 12 1/2 TON	Asset Viewer Manager database
84	108412	529250	2320011077155	D1158	GENERATOR, 10KW,60HZ	Asset Viewer Manager database
85	108442	566003	2410012541667	B2460	TRLR CARGO 1 1/2T 2-WHEEL	Asset Viewer Manager database
86	108453	537034				data sheets recorded during tagging of PEI shipboard
87	108455	529036	2320011077155	D1158	GENERATOR, 10KW,60HZ	Asset Viewer Manager database
88	108461	522233	2410011551588	B2462	RADIO SET	Asset Viewer Manager database
89	108467	581120	2320011077155	D1158	TRUCK CARGO 5T W/O/W ISO	Asset Viewer Manager database
90	108473	561336	2320011775167	D0209	TRLR CARGO 1 1/2T 2-WHEEL	Asset Viewer Manager database
91	108477	523273	2350010818138	E0846	GENERATOR, 3 KW, 60 HZ	Asset Viewer Manager database
92	108480	582233	2320011077156	D1158	TRK UTIL CARGO TRP C W/O/W HMMV	Asset Viewer Manager database
93	108483	582208	2320011077156	D1158	TRUCK, DUMP, 6X6 5T W/W	Asset Viewer Manager database
94	108490	536169	2320011077155	D1158	ROWPU	Asset Viewer Manager database
95	108492	545778				data sheets recorded during tagging of PEI shipboard
96	108493	581130	2320011077155	D1158	TRUCK CARGO 5T W/O/W ISO	Asset Viewer Manager database
97	108499	529110	2320011077155	D1158	GENERATOR, 10KW,60HZ	Asset Viewer Manager database
98	108508	568476	3805012793635	B2567	TRAILER, TANK, WATER, 400 GAL, 1 1/2T 2-WHL	Asset Viewer Manager database
99	108512	582227	2320011077156	D1158	TRK UTIL CARGO TRP C W/O/W HMMV	Asset Viewer Manager database
100	108513	525124	2320011775167	D0209	GENERATOR, 3 KW, 60 HZ	Asset Viewer Manager database
101	108517	545745				data sheets recorded during tagging of PEI shipboard
102	108518	519070				data sheets recorded during tagging of PEI shipboard
103	108525	581117	2320011077155	D1158	TRUCK CARGO 5T W/O/W ISO	Asset Viewer Manager database
104	108528	553343	2320011077155	D1158	POWER UNIT 12 1/2 TON	Asset Viewer Manager database
105	108531	545848				data sheets recorded during tagging of PEI shipboard

Item	TAG ID	S/N	NSN	TAM/DODIC	DESCRIPTION	TAG ID-To-PEI Association Basis
106	108544	582210	2320011077156	D1158	TRUCK, DUMP, 6X6 5T WO/W	Asset Viewer Manager database
107	108552	545670				data sheets recorded during tagging of PEI shipboard
108	108553	522139	2410011551588	B2462	RADIO SET	Asset Viewer Manager database
109	108558	560736				data sheets recorded during tagging of PEI shipboard
110	108564	581114	2320011077155	D1158	TRUCK CARGO 5T WO/W ISO	Asset Viewer Manager database
111	108569	582223	2320011077156	D1158	TRUCK, TRACTOR, 6X6 5T	Asset Viewer Manager database
112	108588	525230	2320011760469	D0876	GENERATOR, 3 KW, 60 HZ	Asset Viewer Manager database; not on datasheets
113	108588	551083				data sheets recorded during tagging of PEI shipboard
114	108590	582841	2320011077155	D1158	TRK UTIL CARGO TRP C W/W	Asset Viewer Manager database
115	108591	529782	2320011467189	D1159	GENERATOR, 10KW,400HZ	Asset Viewer Manager database
116	108593	515875	2320010478753	D1134	RADIO SET	Asset Viewer Manager database
117	108595	582215	2320011077156	D1158	TRK UTILITY,TOW CARR, W/W	Asset Viewer Manager database
118	108598	584328				data sheets recorded during tagging of PEI shipboard
119	108602	554505				data sheets recorded during tagging of PEI shipboard
120	108603	550940	2320011775167	D0209	CHAS.TRLR 1TON	Asset Viewer Manager database
121	108605	582201	2320011077156	D1158	TRUCK, DUMP, 6X6 5T WO/W	Asset Viewer Manager database
122	108606	564118	2320011760467	D0878	TRLR CARGO 1 1/2T 2-WHEEL	Asset Viewer Manager database; not on data sheets
123	108606	551121				data sheets recorded during tagging of PEI shipboard
124	108607	581547	2310011112274	D1001	TRUCK CARGO 5T WO/W ISO	Asset Viewer Manager database
125	108609	581955	2320011467189	D1159	TRUCK CARGO 5T WO/W ISO	Asset Viewer Manager database
126	108612	535927	2320011077155	D1158	TRAM	Asset Viewer Manager database
127	108614	535224	2320011077155	D1158	TRK FORKLIFT RGH. TERR. 4000	Asset Viewer Manager database
128	108615	546793	2320011467190	D1159	CHAS.TRLR GEN.PUR. 3.5TON	Asset Viewer Manager database
129	108616	581543	2310011112274	D1001	TRUCK CARGO 5T WO/W ISO	Asset Viewer Manager database
130	108617	582844	2320011077155	D1158	TRK UTIL CARGO TRP C W/FP HMMV	Asset Viewer Manager database
131	108626	582202	2320011077156	D1158	TRUCK, DUMP, 6X6 5T WO/W	Asset Viewer Manager database
132	108627	538743	2320011077155	D1158	ROWPU	Asset Viewer Manager database; not on data sheets
133	108633	517381				data sheets recorded during tagging of PEI shipboard
134	108637	569717				data sheets recorded during tagging of PEI shipboard
135	108640	552124	2320011467189	D1159	POWER UNIT 12 1/2 TON	Asset Viewer Manager database
136	108644	582203	2320011077156	D1158	TRUCK, DUMP, 6X6 5T WO/W	Asset Viewer Manager database
137	108648	554420				data sheets recorded during tagging of PEI shipboard
138	1065345	581935				Asset Viewer Manager database

Notes for List of PEI Tagged for Offload:

- 1) This spreadsheet was compiled from the data sheets that were recorded while the PEI were tagged on the MV WILLIAMS and the database of the AVM. The records are sorted on the 'TAG ID' column in ascending order. The column titled 'TAG ID-To-PEI Association Basis' indicates the source from which the data was derived. There were discrepancies between the two sources. Where the differences are irreconcilable, the data sheets filled in while shipboard are considered correct.
- 2) The total number of PEI that were tagged is indeterminate. There were between 133 and 136 PEI tagged. There are a total of 138 tags on the list. There are two tag IDs (108588 and 108606) duplicated on the list. The duplication exists because the PEI to which the tags are attached differs in the AVM and datasheets. This indicates that the AVM was incorrect, thus reducing the total of 138 to 136. There were 3 other tag IDs (106535, 107613 and 108627) recorded in the AVM database that were not recorded on the data sheets. This would indicate that there was either an error in the AVM database or omissions from the datasheets. In either event, this error results in the lowest number of PEI possibly being tagged to 133.
- 3) Record 81 – The last digit in the S/N on the data sheets was unclear. It may have been a 2 or a 4.
- 4) Record 138 – The tag ID on this item is incorrect. All tags used in the exercise had IDs consisting of 6 numeric characters in length.

Appendix D2: Selection of Completed Data Sheets

6.1.1 Organic Marine Corps AIT Operations

POG

1. Record the number of personnel required to perform barcoding operations:

2 # 0481 Mos ~~for~~ Others are from supply, getting training.

2. Describe the actions of barcode scanners – include any use of pen and logbook:

No logbook @ POG out

Vehicle drives up to station checkpoint. Barcode is scanned.
"Cradle Pump" (reconciliation) ~~when~~ after all ^{from the convoy} ~~indicated~~ vehicles arrive.

3. Describe the process by which the data from the barcode scanners is transferred to the MDSSII computer. Measure and record the time required for this data transfer to occur.

Docking – Data from the scanners is downloaded to LFSP MDSS II computer by docking the scanner into the cradle, which is connected to the MDSS II computer by serial cable ~~cradle~~. Band rate = 115K ^{a new}

Time req'd is short because ~~the~~ MDSS II database is created for LFSP-monitored assets.

Barcode scanners can also be ^{auto}downloaded using RF. If using PC card receiver, range is about 300 ft (max).

Date: May 3, 4 If using access point, range is up to 1000 ft.

POG

4. Describe the process used to forward reconciled MDSSII files to the next scanning point. Also document how that file is handled and used at that next point.

N/A at POG/LFSP
LFSP SSGF Garnitt POG downloads data to LFSP. LFSP emails to AAOG. LFSP doesn't email to AAOE. AAOE sends directly to AAOG, instead of through LFSP.

5. Record the number of times that the barcode scanner is required to be docked at a docking station. Record the number of scans that the barcode scanner captured.

LFSP S/4 SSGF Garnitt Docked every 2 hrs. (30 min before data sent to AAOG). ~17 scans per.

Date: May 4

POG LFSP and POG, MCC

6. Discuss how the reconciliation process is performed at this location. The process is performed to compare the inventory of equipment established as arriving at this location using the barcode scanners with the inventory of equipment established at the previous location. Include in this discussion, the time required for the reconciliation, any discrepancies identified and how these were solved.

The ~~POG~~ 5 stations (POG in, POG out, MCC in, MCC out, and ~~POG~~ = ^{DCL} Dissociated Lot) ~~are~~ each have their own barcode scanner. They are required to transfer their data to the LFSP MDSS II computer 30 minutes before the LFSP sends an email update to AADG (this is done every 2hrs from 0900-1700).

A new MDSS II database was created at the beginning of the exercise to store the items scanned at LFSP only. There is only one entry for each item. New location data overwrites the old location data. If, for instance, the ~~old~~ item's NSN and ser # don't match both the NSN + ser # of the existing record, then an error message ^{appears} ~~is generated~~.

When the new scanner data is downloaded to the MDSS II computer, a new Cargo ^{table} record is created. This data contains the barcode data only - i.e., UIC, NSN, PKG ID, Item ID, S/N, MSE, Nomenclature, length, width, Ht, Wt. It is imported to a local UDL (created for C602) where the item data is associated w/ the ^{local} UDL data.

exported
from MDSS II
for LOGMS

.pex MDSS II Table for LFSP only items is emailed to AADG.

Cobra Gold 2002
TAV Experiment
Appendix C
Page 4 of 23

AAOE – GCE

1. Record the number of personnel required to perform barcoding operations:

1 - 0431 - Sgt Sloan
1 - 3043 (Supply)

2. Describe the actions of barcode scanners – include any use of pen and logbook:

One scanner for arrival at GCE.

One scanner for completion of JLT1.

~~Pen~~ (logbook not used).

3. Describe the process by which the data from the barcode scanners is transferred to the MDSSII computer. Measure and record the time required for this data transfer to occur.

GCE has its own MDSSII Computer. File is emailed to AAOG every 2 hours from 0900-1700. ^{On current status}

Date: 5/6/02
Sgt Sloan

Cobra Gold 2002
TAV Experiment

1. LFSP SCANS RECORDS

- PDG IN / OUT / (DISSOCIATED LOT IN ALSO)
- MCC IN / MCC OUT \Rightarrow SEND TO AAOG

2. MOVEMENT TO AAOES

SCAN AAOE IN

~~\Rightarrow SEND TO LFSP~~

\hookrightarrow SENDS TO AAOG

3. AAOES SIMULATE/ELECTRON JLT1 COMPLETE

~~\Rightarrow SEND TO LFSP~~

\hookrightarrow SENDS TO AAOG

4. AAOG CREATES CMR in excel or MDSSII

\Rightarrow SEND TO AAOES

\hookrightarrow SIMULATE SENDING HARD COPY

\hookrightarrow USING UNIT

} end of daily

PRIORITIES OF COMMUNICATION:

1. ELECTRONIC MAILED DATA
2. COURIER DISK
3. PHONCON

LFSP 5/8/02

Gy Sgt Hanna

Cpl Lujan - 0431 keeps log of items scanned at PDG IN when scanner data is dumped. Also used to cross off unloaded items from the Load Plan.

Time, Ship (W/L), ^{PISTID} Str #, ^{Item ID} TAM, from New Cargo Table

POG IN goes to separate UDL, ~~starts~~ (started on 5/7 - new idea)

~~doesn't~~ doesn't go to LFSP UDL.

POG 5/8/02

~~HR~~
POG-IN

PVC Report - 2 hrs, manually tracked by POG-in every 2 hrs from start of offload

LCpl Pollack - POG IN 0481 Landing Spt

LCpl ^{Estrella} Duran - POG HQ 0481
Camp Foster, Okla - eaduran2000@cs.com

POG out keeps track of what needs to be dissociated.

POG IN Tracking Sheet (pm)

transmission
by
radio
↓
used
for
Timeline, etc

↓
Offload Tracking Sheet (excel)

↓
PVC
- to LFSP
Luminus

↓
Vehicle Totals
- sent to AAOE's

↓
PVC
Williams

Appendix A: List of PEI to be Tagged

CSSE
MK48 561114
ABS Mod Disabled
②

RFID Tag Number	Item Id	Serial Number	Description	Qty	
-106536 ✓	A1935	✓554587 GC2/145	RADIO AN/wMRC138	10	1 NO
-108531 ✓	A1935	✓545848 GC2/145	RADIO AN/wMRC138		2 NO
-107637	A1935	*582843	RADIO AN/wMRC138		3 ✓
-108272 ✓	A1935	✓545700 GC2/145	RADIO AN/wMRC138		4 NO
-108310	A1935	*535486	RADIO AN/wMRC138		5 ✓
-108302 ✓	A1935	✓554480 GC2/145	RADIO AN/wMRC138		6 NO
-108493	A1935	*581130	RADIO AN/wMRC138		7 ✓
-108483	A1935	*582208	RADIO AN/wMRC138		8 ✓
-107771 ✓	A1935	✓536048 GC2/145	RADIO AN/wMRC138		9 NO
-106516 ✓	A1935	✓554456 GC2/145	RADIO AN/wMRC138		10 ✓
-108387	A1955	*535371	RADIO TERM SET MRC142	2	1 ✓
-108480	A1955	*582233	RADIO TERM SET MRC142		2 ✓
-108195	A1957	*582849	RADIO SET MRC-145	17	1 ✓
-108307	A1957	*581925	RADIO SET MRC-145		2 ✓
108512	A1957	582849	RADIO SET MRC-145		3 ✓
-108512	A1957	*582227	RADIO SET MRC-145		4 ✓
-108496	A1957	*536169	RADIO SET MRC-145		5 ✓
-108247 ✓	A1957	✓535591 CS22/138	RADIO SET MRC-145		6 ✓
-108263	A1957	*561114	RADIO SET MRC-145		7 ✓
-107583	A1957	*581861	RADIO SET MRC-145		8 ✓
-108192	A1957	*582217	RADIO SET MRC-145		9 ✓

05/23/2002 12:22 7603625434 JOHN BOWMER PAGE 03

20 7

Appendix A: List of PEI to be Tagged

RFID Tag Number	Item Id	Serial Number	Description	Qty	
108615	A1935	* 546793	RADIO AN/wMRC138	10	1 ✓
108614	A1935	* 535224	RADIO AN/wMRC138		2 ✓
108612	A1935	* 535927	RADIO AN/wMRC138		3 ✓
108569	A1935	* 582223	RADIO AN/wMRC138		4 ✓
108225	A1935	* 582847	RADIO AN/wMRC138		5 ✓
108590	A1935	* 582841	RADIO AN/wMRC138		6 ✓
108626	A1935	* 582202	RADIO AN/wMRC138		7 ✓
108609	A1935	* 581955	RADIO AN/wMRC138		8 ✓
108290	A1935	* 581133	RADIO AN/wMRC138		9 ✓
108259	A1935	* 581857	RADIO AN/wMRC138		10 ✓
108640	A1955	* 552124	RADIO TERM SET MRC142	2	1 ✓
108341 ✓	A1955	✓ 560752 C552/142	RADIO TERM SET MRC142		2 ✓
108345	A1957	* 553081	RADIO SET MRC-145	17	1 ✓
108591	A1957	* 529782	RADIO SET MRC-145		2 ✓
108330	A1957	✓ 545800 C552/145	RADIO SET MRC-145		3 ✓
108344	A1957	* 581843	RADIO SET MRC-145		4 ✓
108558 ✓	A1957	✓ 560736 C552/142	RADIO SET MRC-145		5 ✓
108350	A1957	* 551041	RADIO SET MRC-145		6 ✓
108492 ✓	A1957	✓ 545778 C552/145	RADIO SET MRC-145		7 ✓
108204 ✓	A1957	✓ 554435 C552/145	RADIO SET MRC-145		8 ✓
108328	A1957	* 544060	RADIO SET MRC-145		9 ✓

Appendix D3: Network Analysis Data

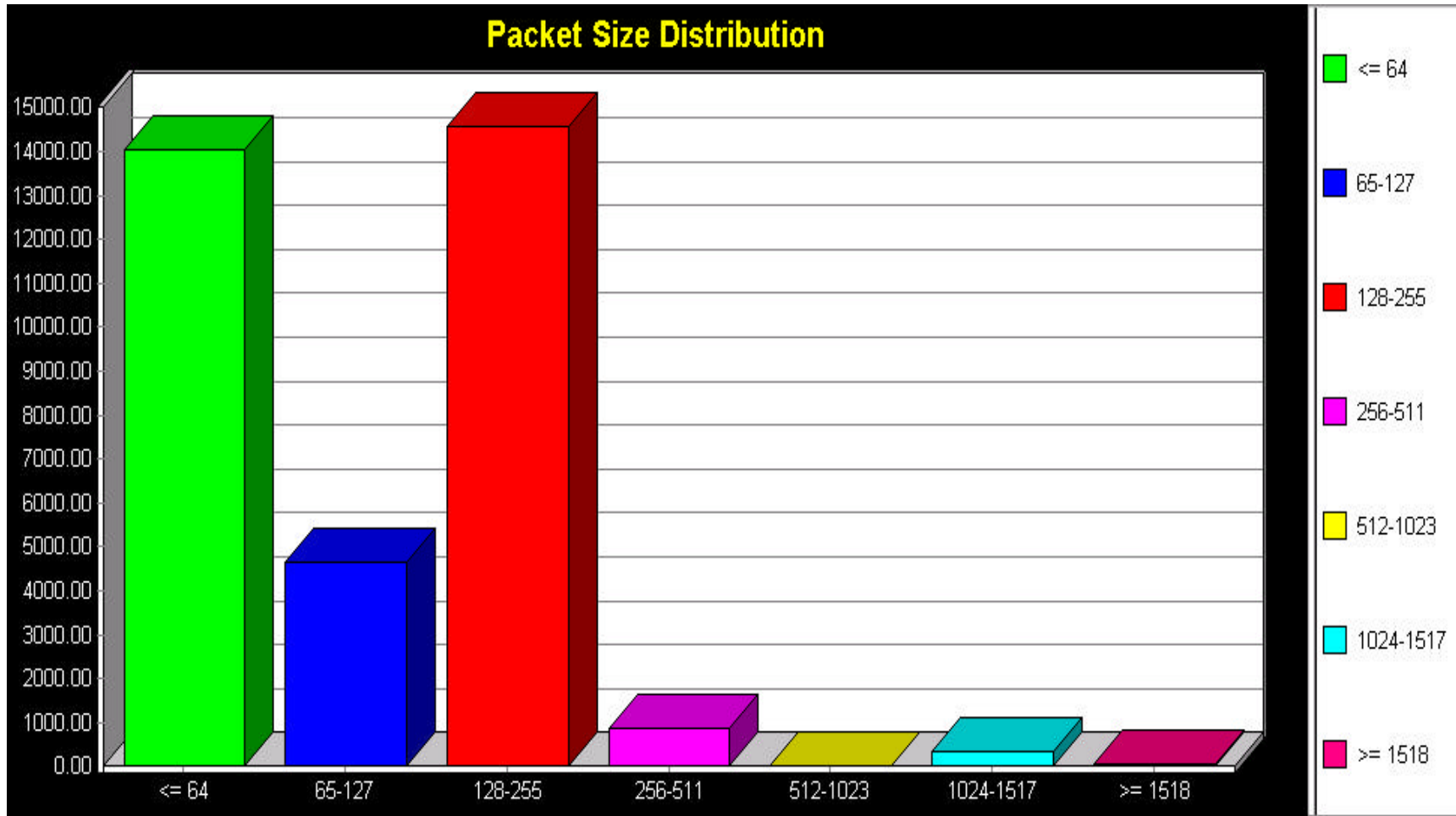

All Network Traffic Monitored by RFID Computer at LFSP

Total Bytes:	5,032,264
Total No. Packets:	34,517
Data Capture Start Time:	3 May 2002, 0517 hrs (local Thai time)
Data Capture Duration:	5 hrs, 42 min
Filename:	CG02 SAMS POG-MCC 3MAY2002205951.pkt

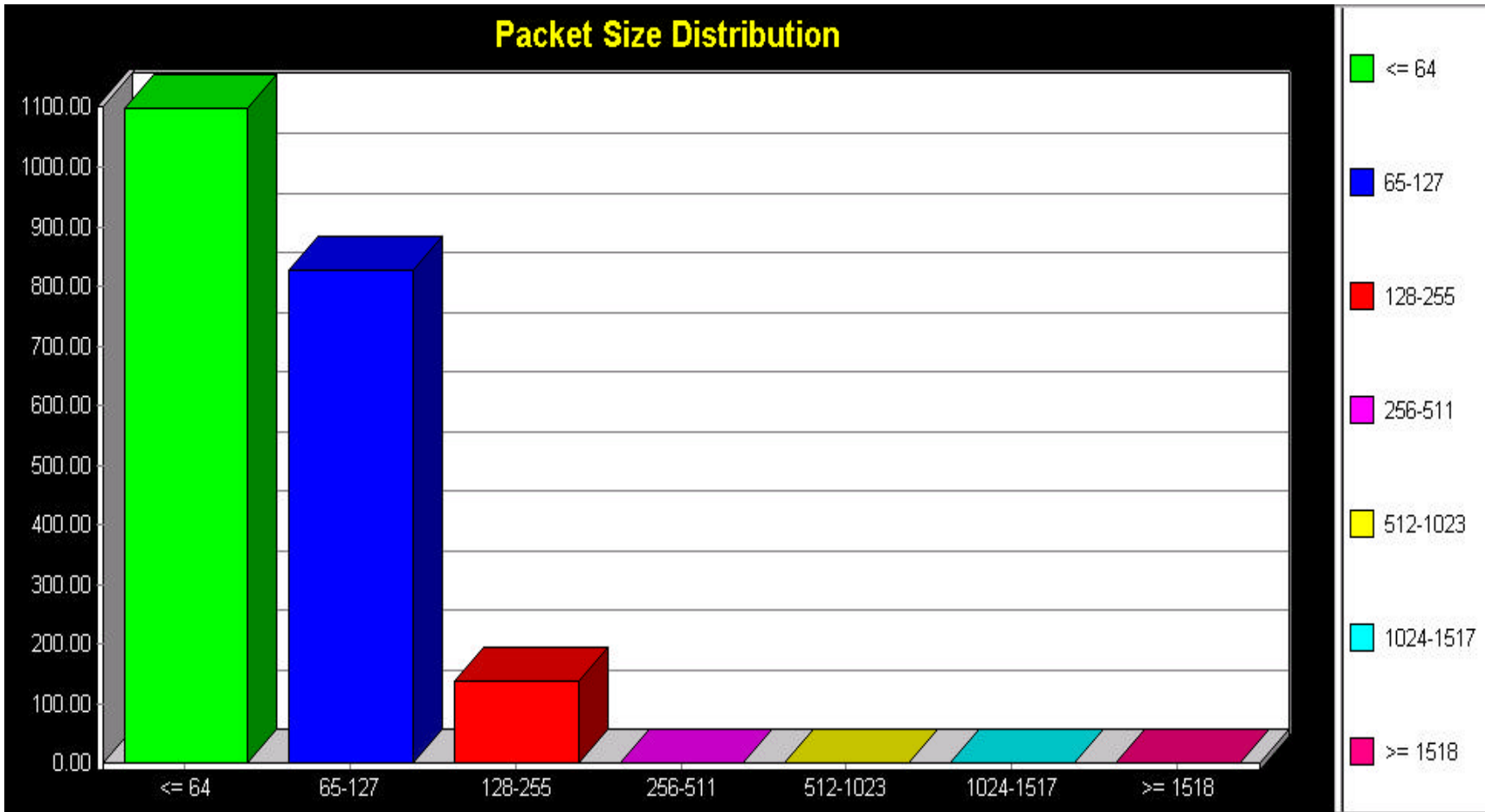

RFID Traffic on Network Monitored by RFID Computer at LFSP

Total Bytes: 163,467
 Total No. Packets: 2,064
 Data Capture Start Time: **3 May 2002, 0517 hrs** (local Thai time)
 Data Capture Duration: 5 hrs, 42 min
 Filename: CG02 SAMS POG-MCC 3MAY2002205951.pkt

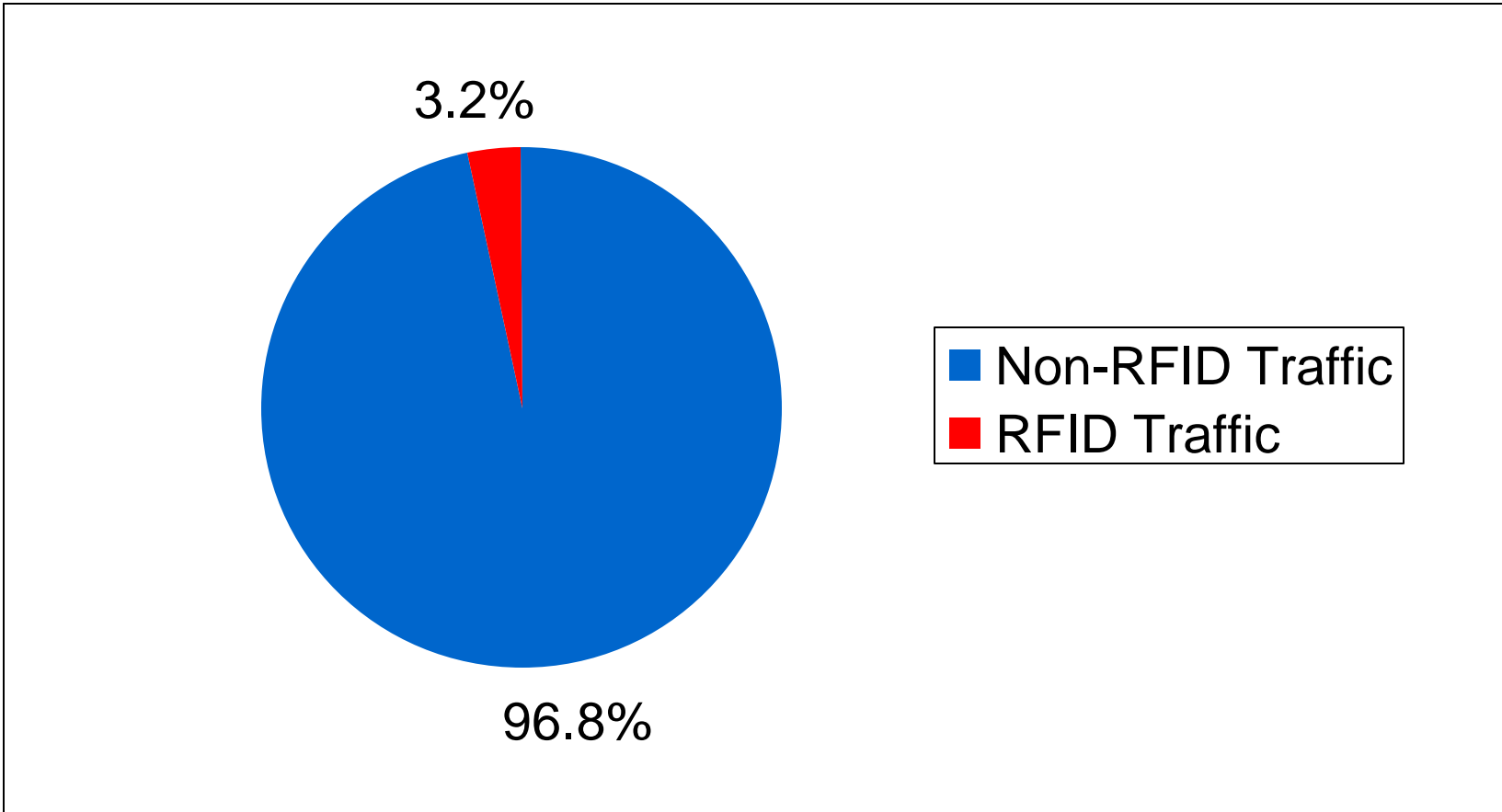

All Network Traffic vs RFID Traffic Monitored by RFID Computer at LFSP

Data Capture Start Time: **3 May 2002, 0517 hrs** (local Thai time)
Data Capture Duration: 5 hrs, 42 min
Filename: CG02 SAMS POG-MCC 3MAY2002205951.pkt

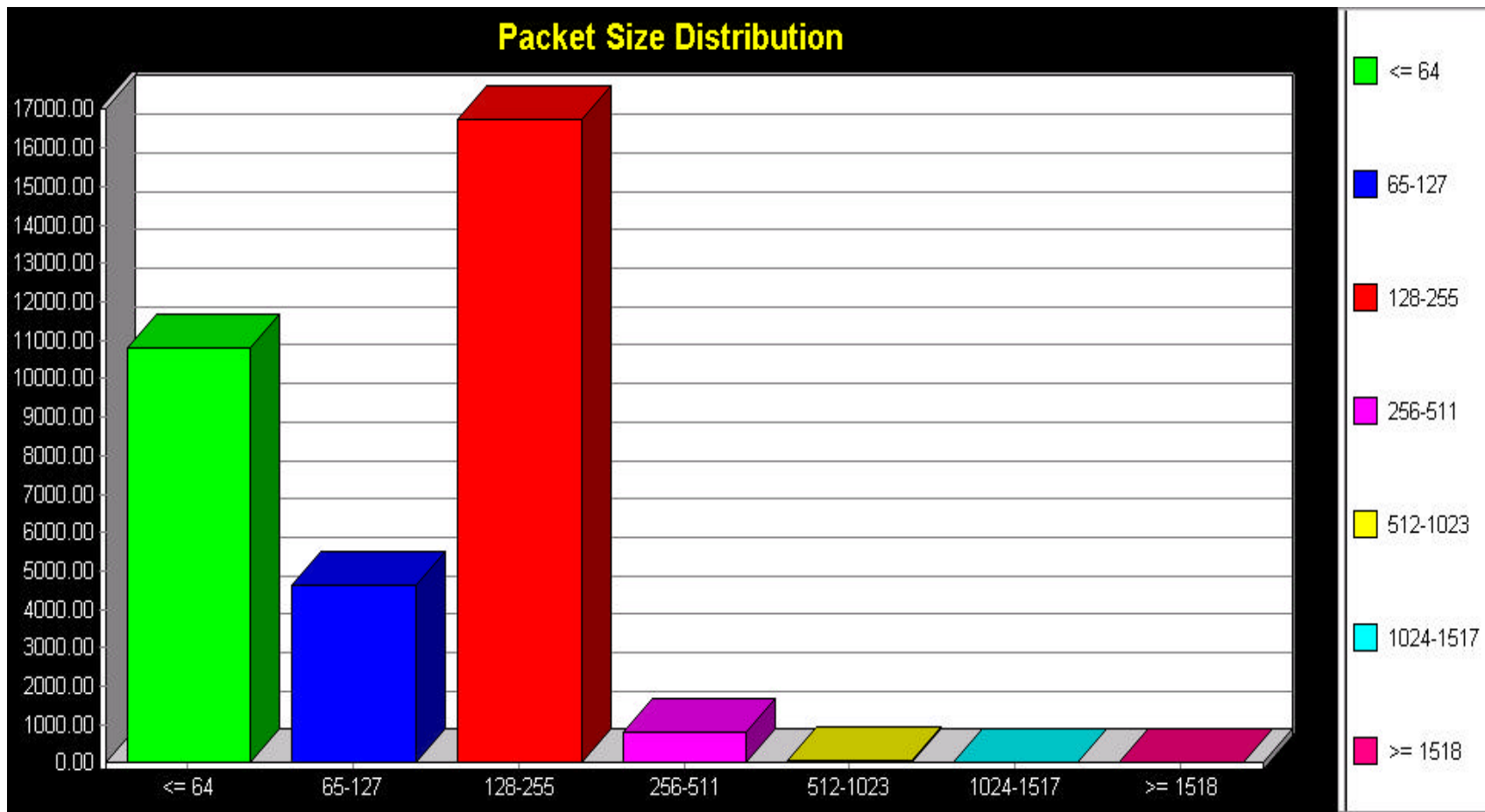

All Network Traffic Monitored by RFID Computer at LFSP

Total Bytes:	4,742,510
Total No. Packets:	33,112
Data Capture Start Time:	5 May 2002, 0502 hrs (local Thai time)
Data Capture Duration:	4 hrs, 10 min
Filename:	CG02 SAMS POG-MCC 4MAY2002191627.pkt

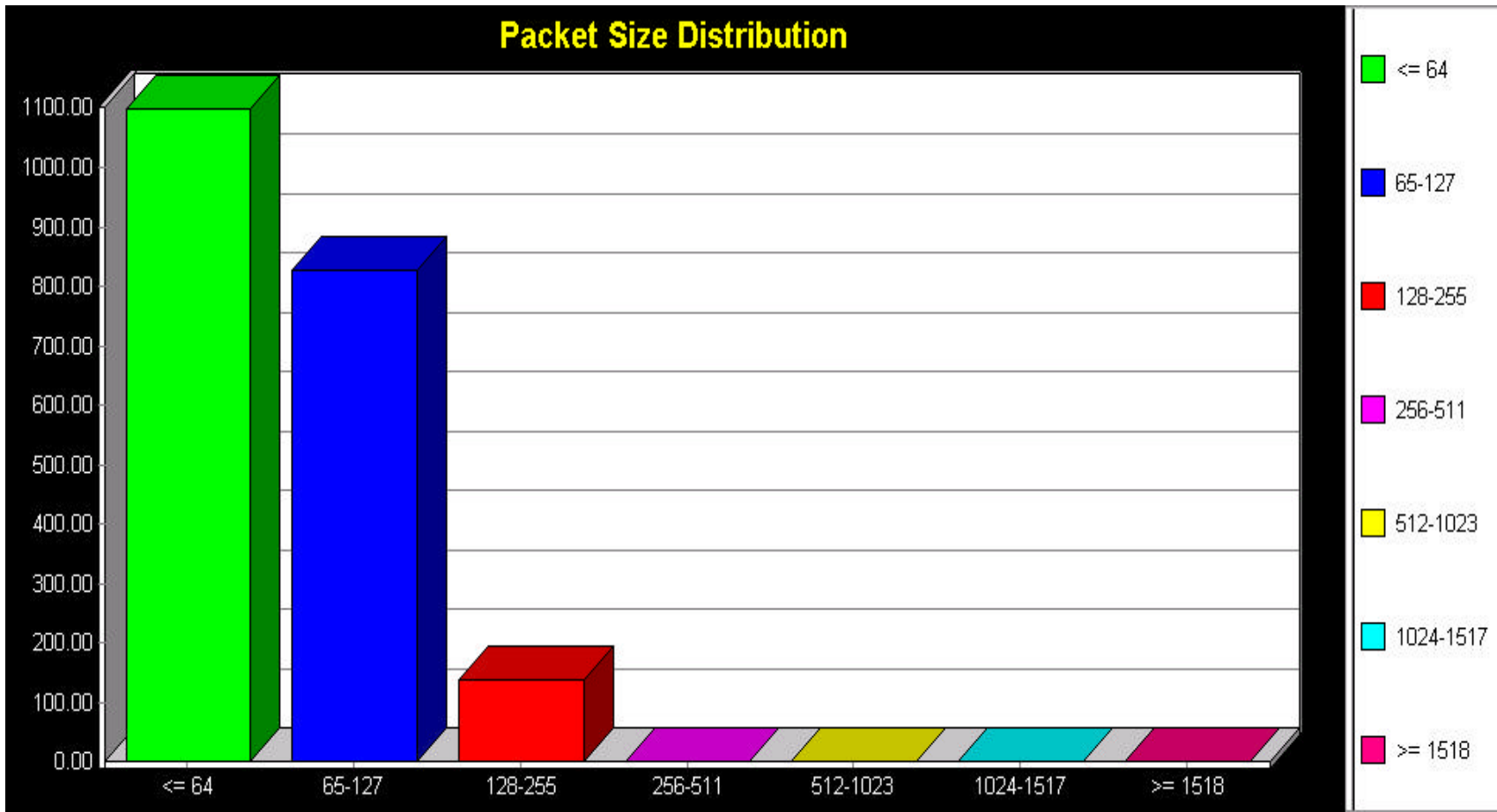

RFID Traffic on Network Monitored by RFID Computer at LFSP

Total Bytes: 149,764
 Total No. Packets: 1,527
 Data Capture Start Time: **5 May 2002, 0502 hrs** (local Thai time)
 Data Capture Duration: 4 hrs, 10 min
 Filename: CG02 SAMS POG-MCC 4MAY2002191627.pkt

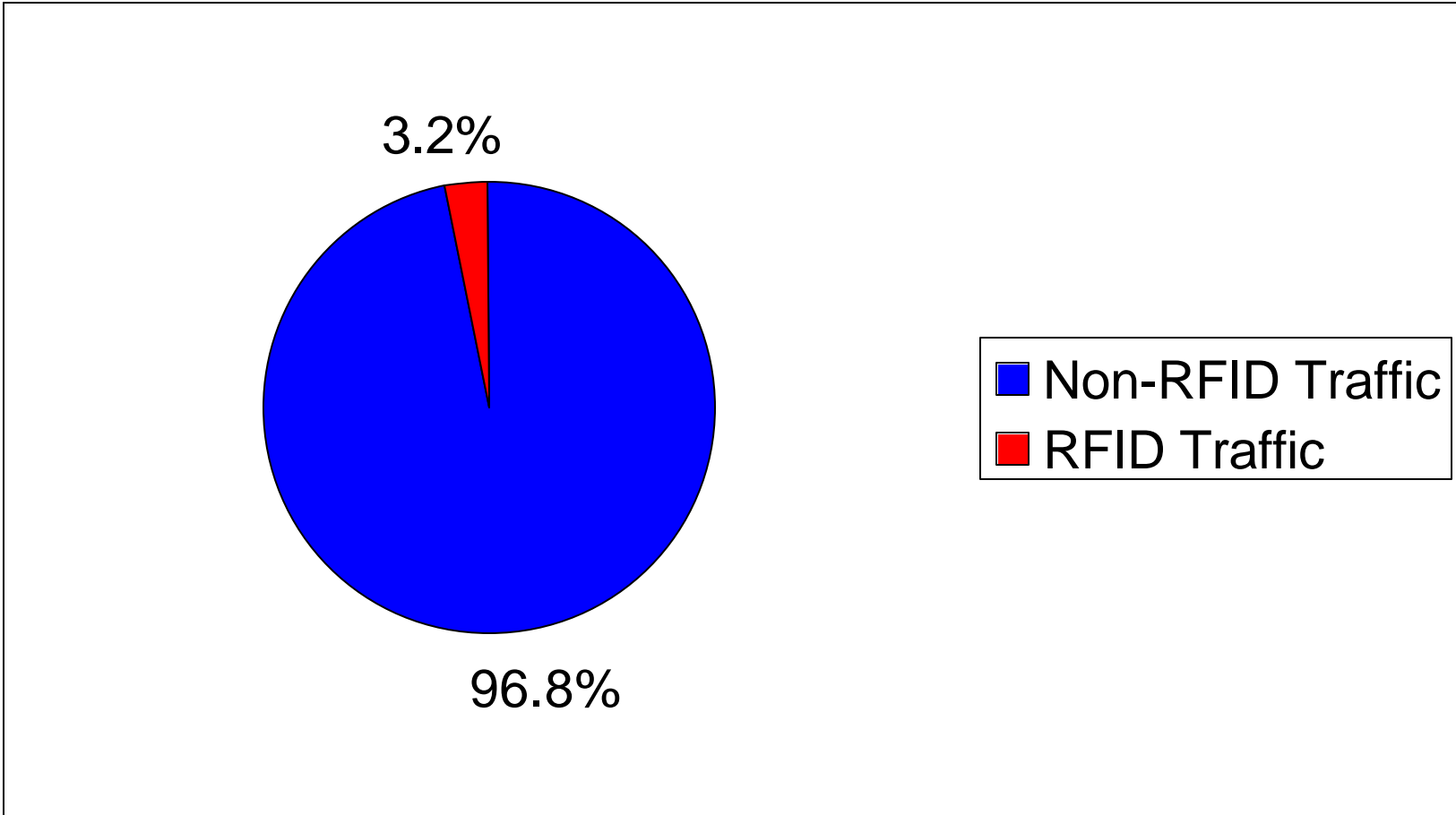

All Network Traffic vs RFID Traffic Monitored by RFID Computer at LFSP

Data Capture Start Time: **5 May 2002, 0502 hrs** (local Thai time)
Data Capture Duration: 4 hrs, 10 min
Filename: CG02 SAMS POG-MCC 4MAY2002191627.pkt

Appendix D4: AVM and Army ITV Screen Shots

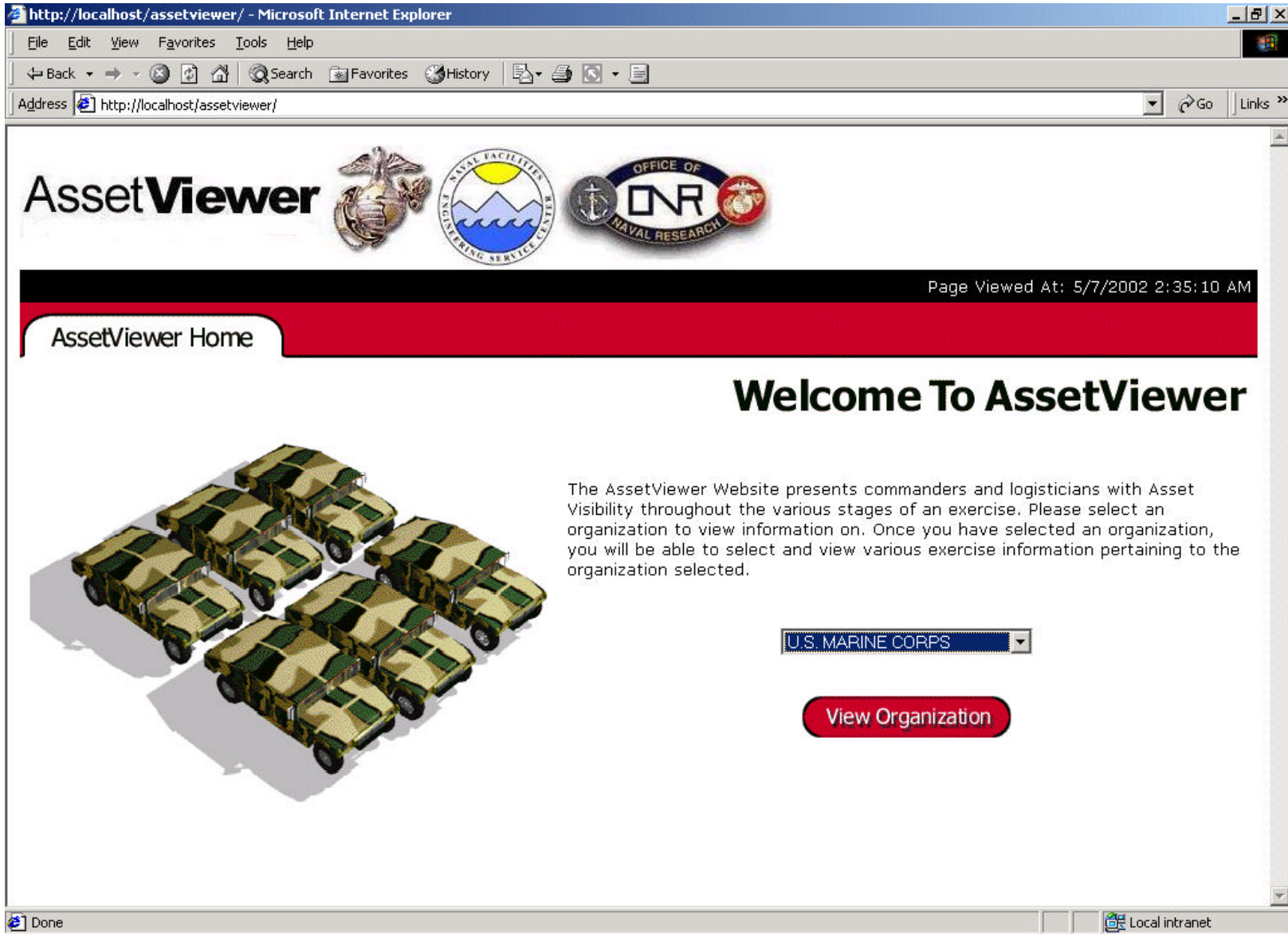

USMC AssetViewer Main Menu Page - Microsoft Internet Explorer

File Edit View Favorites Tools Help

Back Forward Stop Home Search Favorites History Print Refresh

Address <http://localhost/assetviewer/mainmenu.asp> Go Links >>

Main Menu



Search for Asset (NSN, TAMCN, etc...)

This option will allow you to search for an asset by searching on key fields, such as National Stock Number (NSN), TAMCN, etc.

go!!!



Search for Asset by Location

Selecting this option will allow LOCATION specific searching. Once a LOCATION is specified then 'ALL' assets at that current location for a given EXERCISE will be shown.

go!!!



Asset Sorter

This option will allow you to sort asset information by selecting key fields, such as National Stock Number (NSN), TAMCN, etc... The resulting page will display information ordered by the sorting criteria.

go!!!



Administration

This option will allow you to administrate various features of the Asset Viewer

go!!!



Local intranet

http://localhost/assetviewer/Locations/Results.asp - Microsoft Internet Explorer

File Edit View Favorites Tools Help

Back Forward Stop Home Search Favorites History Print Refresh

Address http://localhost/assetviewer/Locations/Results.asp Go Links >>



[Return to Main Menu](#)

Page Viewed At: 5/8/2002 3:22:07 AM

Search Results

Show Location(s):

Location Search Results

NSN	Serial Number	TAMCN	Description	Unit ID	Last Location	Last Reader	Last Reader Time
2320010478756	517359	D1072	TRUCK, DUMP, 6X6 5T WO/W	WILL 6	8 - MCC	21002 - MCC	05-07-2002 04:17:11
2320011077155	528992	D1158	TRK UTIL CARGO TRP C WO/W HMMV	WILL 6	8 - MCC	21002 - MCC	05-07-2002 04:17:11
2320011077155	536890	D1158	TRK UTIL CARGO TRP C WO/W HMMV	WILL 6	8 - MCC	21002 - MCC	05-07-2002 04:17:11
2320011077155	581117	D1158	TRK UTIL CARGO TRP C W/FP HMMV	WILL 6	8 - MCC	21002 - MCC	05-07-2002 03:42:11
2320011077155	581139	D1158	TRK UTIL CARGO TRP C WO/W HMMV	WILL 6	8 - MCC	21002 - MCC	05-07-2002 03:42:11
2320011077155	582809	D1158	TRK UTIL CARGO TRP C WO/W HMMV	WILL 6	8 - MCC	21002 - MCC	05-07-2002 03:42:11
2320011077155	582844	D1158	TRK UTIL CARGO TRP C W/FP HMMV	WILL 6	8 - MCC	21002 - MCC	05-07-2002 03:42:11
2320011077156	582218	D1158	TRK UTIL CARGO TRP C W/W	WILL 6	8 - MCC	21002 - MCC	05-07-2002 03:42:11
2320011775167	525124	D0209	POWER UNIT 12 1/2 TON	WILL 6	8 - MCC	21002 - MCC	05-07-2002 04:17:11
4210011379943	528920	D1064	TRK F-F AIRCRFT-CR/ST FIRE	WILL 6	8 - MCC	21002 - MCC	05-07-2002 03:42:11
5820014206621	545700	A1957	RADIO SET, MRC-145	WILL 6	8 - MCC	21002 - MCC	05-07-2002 04:17:11
5820014206621	560897	A1957	RADIO SET, MRC-145	WILL 6	8 - MCC	21002 - MCC	05-07-2002 03:42:11

Local intranet

http://localhost/assetviewer/Assets/Details.asp?NSN=5820014206619&SERIAL_NUMBER=535864 - Microsoft Internet Explorer

File Edit View Favorites Tools Help

Back Forward Stop Home Search Favorites History Print Refresh

Address http://localhost/assetviewer/Assets/Details.asp?NSN=5820014206619&SERIAL_NUMBER=535864 Go Links >>

Description: M1A1 Abram Tank

PLAN_ID 7414	UIC WILL 6	NSN 5820014206619	PKG_ID 535864
SERIAL_NUMBER 535864	NSN_CONFIGURATION	ITEM_ID A1935	ULN
TCN	LANDING_SERIAL	DESCRIPTION RADIO SET, MRC-138	
WEIGHT_LB	LENGTH_IN	WIDTH_IN	HEIGHT_IN
MAX_WEIGHT	LTI_CODE	JCS_CARGO_CATEGORY	IMO_CODE
UN_CODE	QUANTITY_PER_CARGO	NUMBER_OF_CARGOS	MSE GCE
UPTI_CODE	SUC	RUC	SECTION
SEAL_NUMBER	PRIORITY_ORDER	ASSOCIATION	PARENT_PKG_UIC
PARENT_PKG_NSN	PARENT_PKG_ID	STACK_LIMIT	GEOLOC_CODE
AIT_LOCATION_CODE	PACKAGE_LOT_NUMBER	REMARKS D	DATE_AND_TIME_GROUP
TEAM_NAME	APPLIED_MEASURE	COMMAND_ATTENTION	NET_EXPLOSIVE_WEIGHT
EMBARK_CATEGORY	SUPPLY_CLASS	TEMPLATE	X_COORDINATE_IN
Y_COORDINATE_IN	ROTATION_ANGLE_DEG	COMPLETION_TIME	SCALE_FACTOR
ROUTE	CONVOY_NAME	MOVEMENT_STATUS	PRIMARY_TCN
EXPIRATION_DATE	INVENTORY_DATE	OWNER_CODE	SHELF_LIFE_CODE
UNIT_OF_ISSUE	TEMPLATING_STATUS	LOCATION	MANUFACTURE_CODE
MANUFACTURE_DATE	MISSION_NUMBER	MANI_ONLOAD_SCHED_DEPART 1	MANI_ONLOAD_REPORT_DEPART
MANI_ONLOAD_SCHED_ARRIVE	MANI_ONLOAD_REPORT_ARRIVE	MANI_ONLOAD_GEO	MANI_OFFLOAD_SCHED_DEPART
MANI_OFFLOAD_REPORT_DEPART	MANI_OFFLOAD_SCHED_ARRIVE	MANI_OFFLOAD_REPORT_ARRIVE	MANI_OFFLOAD_GEO
LOGICAL_SET	ASSET_STATUS	MODEL_NUMBER	ASSET_TYPE
TAG	TSS_LOCATION	TAG_ID	PACK_TYPE



Done Local intranet

http://localhost/assetviewer/Sort/offloadStatus.asp - Microsoft Internet Explorer

File Edit View Favorites Tools Help

Back Forward Stop Home Search Favorites History

Address http://localhost/assetviewer/Sort/offloadStatus.asp Go Links >>

[Return to Main Menu](#)

Page Viewed At: 5/8/2002 3:25:39 AM

Offload Status

Offload Status Report

MSE	Total Authorize	Total Delivered	Status
CE	10	9	
GCE	69	23	
ACE	22	11	
CSSE	29	1	

Less than 60% Delivered
 Between 60% and 80% Delivered
 Greater than 80% Delivered





Done Local intranet

http://localhost/assetviewer/Sort/offloadStatusMSE.asp?MSE=GCE - Microsoft Internet Explorer

File Edit View Favorites Tools Help

Back Forward Stop Home Search Favorites History Print Refresh

Address http://localhost/assetviewer/Sort/offloadStatusMSE.asp?MSE=GCE Go Links >>

[Return to Main Menu](#)

Page Viewed At: 5/8/2002 3:26:00 AM

Offload Status

Offload Status Report for GCE

TAMCN	Total Authorize	Total Delivered	Status
A1935	4	3	Yellow
A1957	10	3	Red
B0589	1	0	Red
B2460	1	0	Red
B2462	4	0	Red
B2482	1	0	Red
D1001	2	0	Red
D1072	1	0	Red
D1158	34	16	Red
D1159	2	1	Red
E0796	1	0	Red
E0846	8	0	Red

Done Local intranet

Shipments associated with the Military Exercise / Operation
 Thu MAY 23 2002 19:23:13 GMT

Click [here](#) to download all the data from the query in a pipe delimited file.
 To save the data right click on the link and choose Save Link As and then give a file name, or click the link and use the File menu to save the file.

Number of Records: 100

Viewing : 1-100 of 134

[Top](#) [Next](#)

Exercise	Lead TCN	Consignee DODAAC	Consignor DODAAC	POE	POD	Service	Comm Class	Comments	Write Date
CG02	M2038101210130TIP	MI3001	WIL6	MPS	RE3	USMC	CLASS VII	MR MOON, 3FSSG, THAILAND, CG02-GCE	01-MAY-02 10:39:00
CG02	M2038101210063TIP	M29000	WIL6	MPS	RE3	USMC	CLASS VII	MR MOON, 3FSSG, THAILAND, CG02-CSSE	01-MAY-02 10:28:00
CG02	M2038101210064TIP	M29000	WIL6	MPS	RE3	USMC	CLASS VII	MR MOON, 3FSSG, THAILAND, CG02-CSSE	01-MAY-02 10:29:00
CG02	M2038101210093TIP	M01027	WIL6	MPS	RE3	USMC	CLASS VII	MR MOON, 3FSSG, THAILAND, CG02-ACE	01-MAY-02 10:33:00
CG02	M2038101210040TIP	M29000	WIL6	MPS	RE3	USMC	CLASS VII	MR MOON, 3FSSG, THAILAND, CG02-CSSE	01-MAY-02 09:58:00
CG02	M2038101210131TIP	MI3001	WIL6	MPS	RE3	USMC	CLASS VII	MR MOON, 3FSSG, THAILAND, CG02-GCE	01-MAY-02 10:39:00
CG02	M2038101210125TIP	MI3001	WIL6	MPS	RE3	USMC	CLASS VII	MR MOON, 3FSSG, THAILAND, CG02-GCE	01-MAY-02 11:11:00
CG02	M2038101210108TIP	M29000	WIL6	MPS	RE3	USMC	CLASS VII	MR MOON, 3FSSG, THAILAND, CG02-CSSE	01-MAY-02 12:05:00
CG02	M2038101210107TIP	M29000	WIL6	MPS	RE3	USMC	CLASS VII	MR MOON, 3FSSG, THAILAND, CG02-CSSE	01-MAY-02 12:04:00
CG02	M2038101210091TIP	M01027	WIL6	MPS	RE3	USMC	CLASS VII	MR MOON, 3FSSG, THAILAND, CG02-ACE	01-MAY-02 10:32:00
CG02	M2038101210109TIP	M29000	WIL6	MPS	RE3	USMC	CLASS VII	MR MOON, 3FSSG, THAILAND, CG02-CSSE	01-MAY-02 12:05:00
CG02	M2038101210073TIP	M01027	WIL6	MPS	RE3	USMC	CLASS VII	MR MOON, 3FSSG, THAILAND, CG02-ACE	01-MAY-02 11:05:00
CG02	M2038101210021TIP	MI3001	WIL6	MPS	RE3	USMC	CLASS VII	MR MOON, 3FSSG, THAILAND, CG02-GCE	01-MAY-02 10:26:00
CG02	M2038101210036TIP	MI3001	WIL6	MPS	RE3	USMC	CLASS VII	MR MOON, 3FSSG, THAILAND, CG02-GCE	01-MAY-02 09:57:00
CG02	M2038101210066TIP	M01027	WIL6	MPS	RE3	USMC	CLASS VII	MR MOON, 3FSSG, THAILAND, CG02-ACE	01-MAY-02 11:01:00
CG02	M2038101210078TIP	MI3001	WIL6	MPS	RE3	USMC	CLASS VII	MR MOON, 3FSSG, THAILAND, CG02-GCE	01-MAY-02 11:05:00
CG02	M2038101210067TIP	MI3001	WIL6	MPS	RE3	USMC	CLASS VII	MR MOON, 3FSSG, THAILAND, CG02-GCE	01-MAY-02 11:02:00
CG02	M2038101210027TIP	MI3001	WIL6	MPS	RE3	USMC	CLASS VII	MR MOON, 3FSSG, THAILAND, CG02-GCE	02-MAY-02 03:11:00
CG02	M2038101210002TIP	MI3001	WIL6	MPS	RE3	USMC	CLASS VII	MR MOON, 3FSSG, THAILAND, CG02-GCE	01-MAY-02 08:03:00
CG02	M2038101210030TIP	MI3001	WIL6	MPS	RE3	USMC	CLASS VII	MR MOON, 3FSSG, THAILAND, CG02-GCE	01-MAY-02 09:54:00
CG02	M2038101210068TIP	MI3001	WIL6	MPS	RE3	USMC	CLASS VII	MR MOON, 3FSSG, THAILAND, CG02-GCE	01-MAY-02 11:02:00
CG02	M2038101210094TIP	MI3001	WIL6	MPS	RE3	USMC	CLASS VII	MR MOON, 3FSSG, THAILAND, CG02-GCE	01-MAY-02 08:28:00
CG02	M2038101210081TIP	MI3001	WIL6	MPS	RE3	USMC	CLASS VII	MR MOON, 3FSSG, THAILAND, CG02-GCE	01-MAY-02 10:06:00
CG02	M2038101210072TIP	MI3001	WIL6	MPS	RE3	USMC	CLASS VII	MR MOON, 3FSSG, THAILAND, CG02-GCE	01-MAY-02 11:04:00
CG02	M2038101210031TIP	MI3001	WIL6	MPS	RE3	USMC	CLASS VII	MR MOON, 3FSSG, THAILAND, CG02-GCE	01-MAY-02 09:55:00
CG02	M2038101210097TIP	MI3001	WIL6	MPS	RE3	USMC	CLASS VII	MR MOON, 3FSSG, THAILAND, CG02-GCE	01-MAY-02 12:01:00
CG02	M2038101210092TIP	M01027	WIL6	MPS	RE3	USMC	CLASS VII	MR MOON, 3FSSG, THAILAND, CG02-ACE	01-MAY-02 10:37:00



Operation

give a file name, or click the link and use the File menu to save the file.

Service	Comm Class	Comments	Write Date	Last Location	Last Date	Tag ID
SMC	CLASS VII	MR MOON, 3FSSG, THAILAND, CG02-GCE	01-MAY-02 10:39:00	3MEB COBRA GOLD 02 WRITE	01-MAY-02 10:39:00	108539
SMC	CLASS VII	MR MOON, 3FSSG, THAILAND, CG02-CSSE	01-MAY-02 10:28:00	3MEB COBRA GOLD 02 WRITE	01-MAY-02 10:28:00	108473
SMC	CLASS VII	MR MOON, 3FSSG, THAILAND, CG02-CSSE	01-MAY-02 10:29:00	3MEB COBRA GOLD 02 WRITE	01-MAY-02 10:29:00	108360
SMC	CLASS VII	MR MOON, 3FSSG, THAILAND, CG02-ACE	01-MAY-02 10:33:00	3MEB COBRA GOLD 02 WRITE	01-MAY-02 10:33:00	108518
SMC	CLASS VII	MR MOON, 3FSSG, THAILAND, CG02-CSSE	01-MAY-02 09:58:00	3MEB COBRA GOLD 02 WRITE	01-MAY-02 09:58:00	108192
SMC	CLASS VII	MR MOON, 3FSSG, THAILAND, CG02-GCE	01-MAY-02 10:39:00	3MEB COBRA GOLD 02 WRITE	01-MAY-02 10:39:00	108384
SMC	CLASS VII	MR MOON, 3FSSG, THAILAND, CG02-GCE	01-MAY-02 11:11:00	3MEB COBRA GOLD 02 WRITE	01-MAY-02 11:11:00	108364
SMC	CLASS VII	MR MOON, 3FSSG, THAILAND, CG02-CSSE	01-MAY-02 12:05:00	3MEB COBRA GOLD 02 WRITE	01-MAY-02 12:05:00	108588
SMC	CLASS VII	MR MOON, 3FSSG, THAILAND, CG02-CSSE	01-MAY-02 12:04:00	3MEB COBRA GOLD 02 WRITE	01-MAY-02 12:04:00	108603
SMC	CLASS VII	MR MOON, 3FSSG, THAILAND, CG02-ACE	01-MAY-02 10:32:00	3MEB COBRA GOLD 02 WRITE	01-MAY-02 10:32:00	108633
SMC	CLASS VII	MR MOON, 3FSSG, THAILAND, CG02-CSSE	01-MAY-02 12:05:00	3MEB COBRA GOLD 02 WRITE	01-MAY-02 12:05:00	108606
SMC	CLASS VII	MR MOON, 3FSSG, THAILAND, CG02-ACE	01-MAY-02 11:05:00	3MEB COBRA GOLD 02 WRITE	01-MAY-02 11:05:00	108593
SMC	CLASS VII	MR MOON, 3FSSG, THAILAND, CG02-GCE	01-MAY-02 10:26:00	AAOE, UTAPAO, THAILAND	06-MAY-02 08:55:00	106536
SMC	CLASS VII	MR MOON, 3FSSG, THAILAND, CG02-GCE	01-MAY-02 09:57:00	AAOE, UTAPAO, THAILAND	05-MAY-02 06:44:00	108490
SMC	CLASS VII	MR MOON, 3FSSG, THAILAND, CG02-ACE	01-MAY-02 11:01:00	AAOE, UTAPAO, THAILAND	07-MAY-02 02:13:00	107612
SMC	CLASS VII	MR MOON, 3FSSG, THAILAND, CG02-GCE	01-MAY-02 11:05:00	AAOE, UTAPAO, THAILAND	04-MAY-02 08:27:00	108499
SMC	CLASS VII	MR MOON, 3FSSG, THAILAND, CG02-GCE	01-MAY-02 11:02:00	AAOE, UTAPAO, THAILAND	07-MAY-02 04:29:00	108205
SMC	CLASS VII	MR MOON, 3FSSG, THAILAND, CG02-GCE	02-MAY-02 03:11:00	AAOE, UTAPAO, THAILAND	06-MAY-02 08:52:00	108236
SMC	CLASS VII	MR MOON, 3FSSG, THAILAND, CG02-GCE	01-MAY-02 08:03:00	AAOE, UTAPAO, THAILAND	05-MAY-02 02:51:00	108301
SMC	CLASS VII	MR MOON, 3FSSG, THAILAND, CG02-GCE	01-MAY-02 09:54:00	AAOE, UTAPAO, THAILAND	04-MAY-02 08:27:00	106516
SMC	CLASS VII	MR MOON, 3FSSG, THAILAND, CG02-GCE	01-MAY-02 11:02:00	AAOE, UTAPAO, THAILAND	07-MAY-02 04:20:00	108525
SMC	CLASS VII	MR MOON, 3FSSG, THAILAND, CG02-GCE	01-MAY-02 08:28:00	AAOE, UTAPAO, THAILAND	06-MAY-02 06:33:00	108517
SMC	CLASS VII	MR MOON, 3FSSG, THAILAND, CG02-GCE	01-MAY-02 10:06:00	AAOE, UTAPAO, THAILAND	04-MAY-02 08:27:00	108455
SMC	CLASS VII	MR MOON, 3FSSG, THAILAND, CG02-GCE	01-MAY-02 11:04:00	AAOE, UTAPAO, THAILAND	07-MAY-02 04:08:00	108399
SMC	CLASS VII	MR MOON, 3FSSG, THAILAND, CG02-GCE	01-MAY-02 09:55:00	AAOE, UTAPAO, THAILAND	04-MAY-02 08:26:00	108387
SMC	CLASS VII	MR MOON, 3FSSG, THAILAND, CG02-GCE	01-MAY-02 12:01:00	AAOE, UTAPAO, THAILAND	06-MAY-02 09:00:00	108367
SMC	CLASS VII	MR MOON, 3FSSG, THAILAND, CG02-ACE	01-MAY-02 10:32:00	AAOE, UTAPAO, THAILAND	07-MAY-02 04:20:00	108351

Interrogator Detail - Microsoft Internet Explorer provided by MF50

File Edit View Favorites Tools Help

Address https://147.242.140.23/hsq/Int_Detail.xsq?int_id=21002

Interrogator Detail - Thu MAY 23 2002 19:28:07 GMT

Interrogator ID	21002
Interrogator Name	3MEB WRITE
Interrogator Description	3MEB COBRA GOLD 02 WRITE
Function	WRITE
Location	THAILAND
DODAAC	M20381
Registration Date	01-MAY-02 03:28:00
POC Name	CWO2 PAUL MAJOR
POC Email	majorp@2fssg.usmc.mil
POC Phone	DSN 637-1679
Interrogator Interval	
Upload Interval	
Software Version	B=2.06 C=2.16 U=2.04
Interrogator Mode	Kermit-Modem
Regional Server	KR

TAG = 106539 - Microsoft Internet Explorer provided by NRESC



File Edit View Favorites Tools Help

Address: https://147.242.140.23/cgi-bin/Q-tag.script?tag_id=106539

TAG = 106539

LICENSE PLATE

LEAD TCH: M2038101210130TIP CONTAINER: 23590
 POE: M98 POD: R83
 CONSIGNEE: M13001 CONSIGNOR: WIL6
 HAZMAT: X TP: 2
 SERVICE: USMC OPERATION: CG02
 COMM CLASS: CLASS VII
 FREE TEXT: MR MOON, 3F88G, THAILAND, CG02-GCE

 [TCMD](#)  [COMMODITY](#)

EVENTS

FIRST SIGHTING	LAST SIGHTING	EVENT STATUS	HITS	SITE
01-MAY-02 10:39:00	01-MAY-02 10:39:00	WRITE	1	3MEB COBRA GOLD 02 WRITE

Report: Thu May 23 19:29:35 GMT 2002

[Comments](#)

Commodity for Tag 106539 - Microsoft Internet Explorer provided by NFESC

File Edit View Favorites Tools Help

Address <https://147.242.140.23/TAGS/C106539.html>

Commodity for Tag 106539

COMMODITY

DOC	N&N	NOMEN	REC LIN	QTY	VOI
M2038101210151P	2350010818138	E0846		1	EA

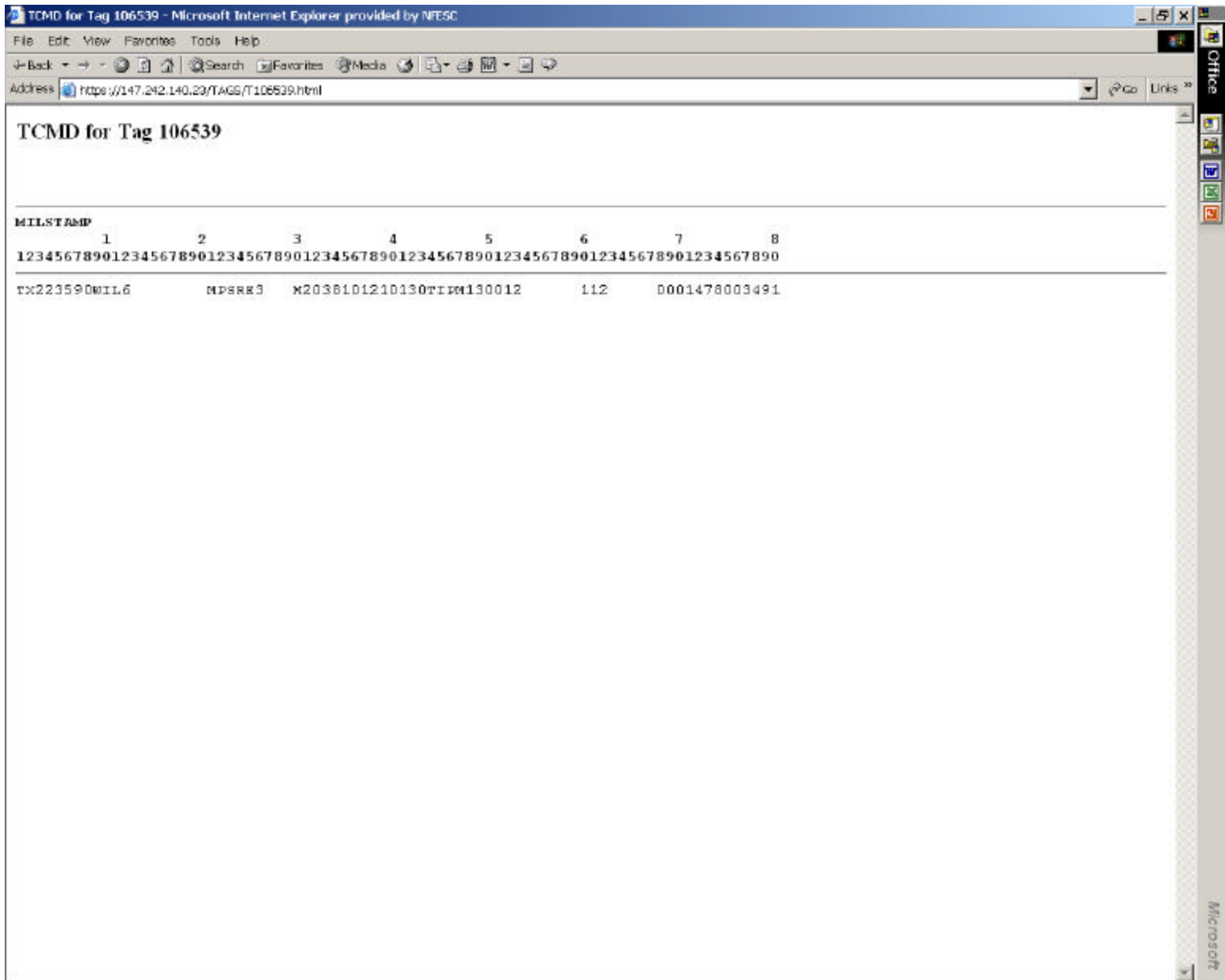

Appendix E: Acronyms

AAOE	Arrival Assembly Operations Element
AIT	Automated Identification Technology
AVM	Asset Viewer/Manager
CONOPS	Concept of Operations
CSSOC	Combat Service Support Operations Center
EDL	Equipment Density List
GR	GateReader
ITV	In Transit Visibility
LOGMARS	Logistics Marking and Reading Symbology
MDSS	MAGTF Deployment Service Support
MCC	Movement Control Center
MPF	Maritime Prepositioning Force
NFESC	Naval Facilities Engineering Service Center
NSN	National Stock Number
NTAV	Navy Total Asset Visibility
ONR	Office of Naval Research
PC	Personal Computer
PCMCIA	Personal Computer Memory Card International Association
PEI	Principle End Item
POG	Port Operations Group
PPE	Personal Protection Equipment
RFID	Radio Frequency Identification
RFL	Radio Frequency Link
RFR 200	Radio Frequency Relay 200
SAMS 2.1.1	Savi Asset Manager System 2.1.1
SN	Serial Number
TAV	Total Asset Visibility
TCP/IP	Transmission Control Protocol/Internet Protocol
UDL	Unit Deployment List
USMC	United States Marine Corps