

ARMY RESEARCH LABORATORY

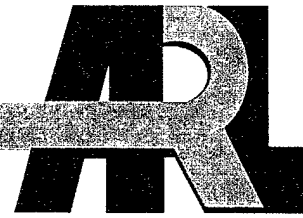

**Dynamic Analysis and Design System Modeling
of the Experimental Unmanned Vehicle**

Peter J. Fazio

ARL-TR-2841

DECEMBER 2002

20030225 044

Approved for public release; distribution is unlimited.

NOTICES

Disclaimers

The findings in this report are not to be construed as an official Department of the Army position unless so designated by other authorized documents.

Citation of manufacturers' or trade names does not constitute an official endorsement or approval of the use thereof.

DESTRUCTION NOTICE—Destroy this report when it is no longer needed. Do not return it to the originator.

Army Research Laboratory

Aberdeen Proving Ground, MD 21005-5066

ARL-TR-2841

December 2002

Dynamic Analysis and Design System Modeling of the Experimental Unmanned Vehicle

Peter J. Fazio

Weapons and Materials Research Directorate

Approved for public release; distribution is unlimited.

Contents

1.	Introduction	1
2.	Procedures	3
	2.1 Modeling the XUV	3
	2.1.1 Bodies and Joints	3
	2.1.2 Forces and Torques	5
	2.1.3 XUV Chassis-Suspension Data and Parameters	8
	2.2 Modeling the SSP	12
3.	Discussion	16
4.	Summary	20
	Bibliography	24
	Report Documentation Page	25

Figures

1. XUV	2
2. XUV, revised body	2
3. XUV frame	4
4. Steering suspension sub-assembly	5
5. Steering actuator, contact segment visible	7
6. Steering actuator, pitman arm contacting segment	7
7. XUV chassis, frame removed	9
8. XUV chassis, four-wheel steering	9
9. XUV complete chassis assembly	10
10. XUV model	11
11. SSP control flow diagram	13
12. Platform gain plot	13
13. Stabilized sensor platform model on board the XUV model	15
14. Stabilized sensor platform model with simulated sensor cone	15
15. XUV chassis pitch rate, generic bump course	17
16. XUV chassis vertical acceleration, generic bump course	18
17. Right front wheel vertical acceleration, generic bump course	19
18. Stabilized sensor platform pitch rate, generic bump course	20
19. XUV chassis and sensor platform pitch rate, comparison 1	21
20. XUV chassis and sensor platform pitch rate, comparison 2	22
21. XUV chassis and sensor platform pitch rate, comparison 3	22

Table

1. XUV physical characteristics	11
---------------------------------	----

INTENTIONALLY LEFT BLANK

DYNAMIC ANALYSIS AND DESIGN SYSTEM MODELING OF THE EXPERIMENTAL UNMANNED VEHICLE

1. Introduction

The Weapons Analysis Branch, Ballistics and Weapons Concepts Division, Weapons and Materials Research Directorate of the U.S. Army Research Laboratory (ARL) built a multi-body engineering-level model of the unmanned ground vehicle platform used in the Office of the Secretary of Defense Demo III Robotics program during fiscal years 2000 and 2001. The intended role of the autonomous robotic vehicle was to be a technology demonstrator to assess the possibility of an unmanned vehicle performing the armor scout mission. The unaided vehicle would travel ahead of the troop section and provide scout reconnaissance without the need for placing a human being into a hostile environment. The vehicle platform used as the basis for the model was the experimental unmanned vehicle (XUV) developed and built by General Dynamics Robotic Systems (GDRS)¹. The XUV is a four-wheeled, Ackerman-steered, all-wheel-drive autonomous vehicle that is approximately 10 feet long, 5 feet wide, and 4 feet high and has a curb weight of ~3000 pounds. The XUV uses a four-cylinder, 78-hp diesel engine that powers a four-wheel hydraulic drive system. A computer model of the XUV was subsequently developed as a further extension of the modeling tools used for analyzing robotic vehicle off-highway mobility and chassis dynamics and to further enhance the fidelity of battlefield simulations in which these vehicles are employed. The XUV is shown in Figure 1 and the XUV with revised body structure is shown in Figure 2.

The XUV was modeled within the structure of the Dynamic Analysis and Design System (DADS) software. DADS is a multi-body engineering computer simulation tool that allows the user to model mechanical system dynamics and kinematics. The user enters the mechanical system data in the form of masses, forces, and constraints, and then the software generates and solves the equations of motion describing the modeled system. DADS also contains control design elements that allow the user to implement a system controller for use during simulation of the modeled system.

Vehicle data for the XUV were obtained from GDRS in the form of computer-aided design (CAD) files and vehicle design parameters. A stabilized sensor platform (SSP) controller was modeled with the DADS control elements, based on a modified algorithm for a pitch-stabilized sighting system from an Abrams M1A1 main battle tank (MBT).

¹ formerly Robotics Systems Technology.

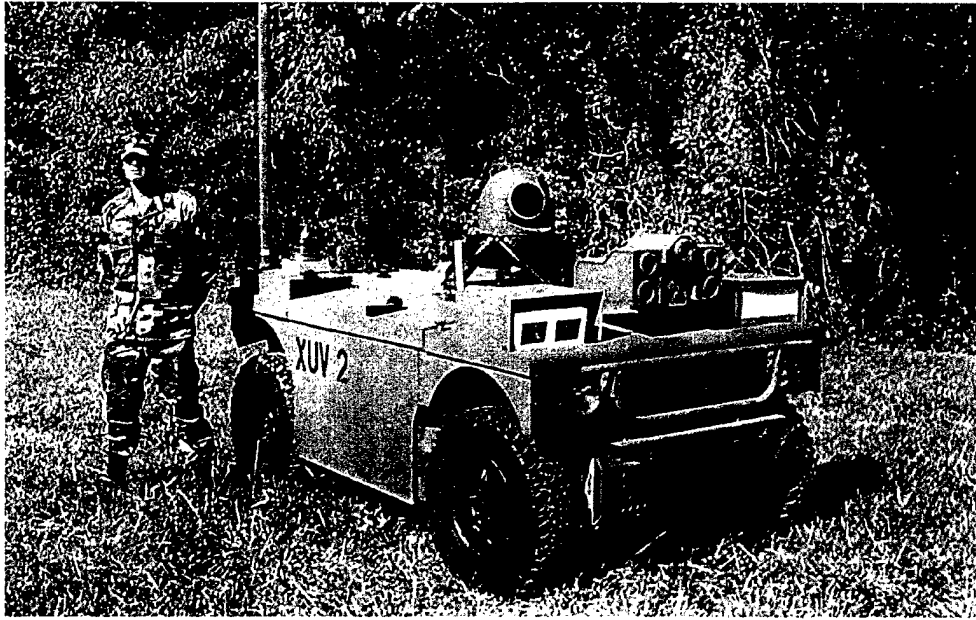

Figure 1. XUV.

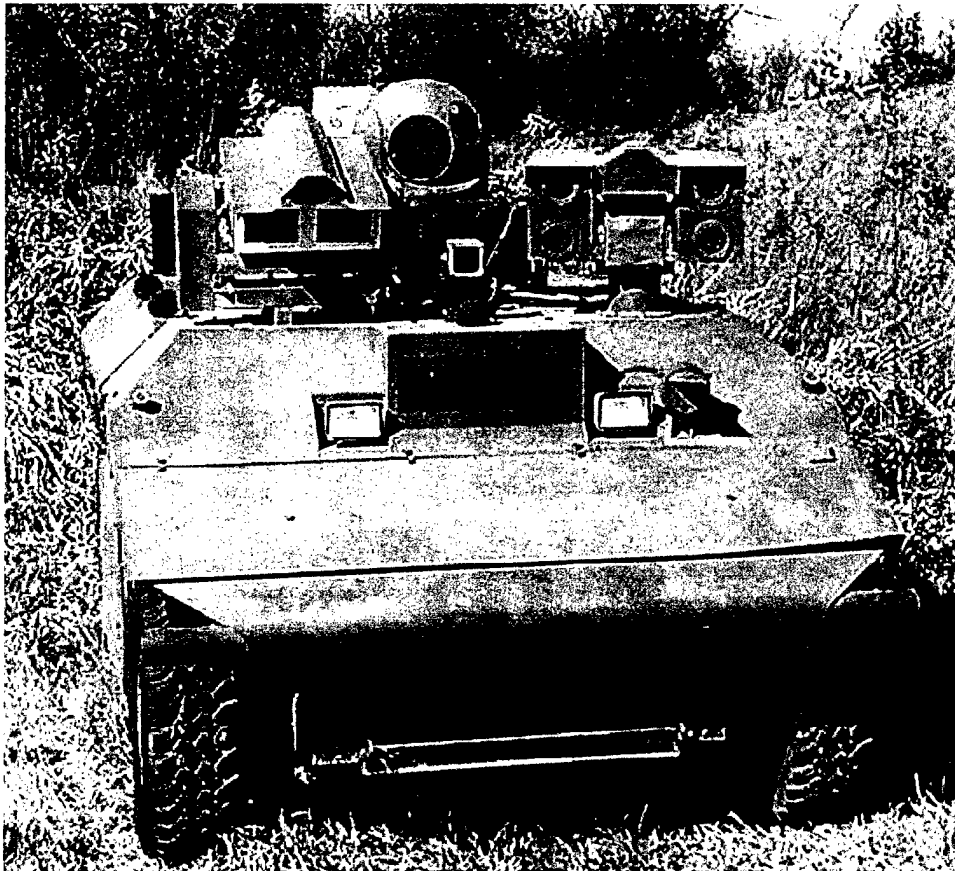

Figure 2. XUV, revised body.

Creation of the DADS XUV model provided us with a tool to evaluate engineering-level concepts down to the component level for small vehicle platforms. This component-level analysis provides for the fidelity necessary to further enhance the realism of robotic vehicle models when they are used as entities in large battlefield simulations. Further, the inclusion of sub-models, such as the SSP, allows us to evaluate the effects of stabilization controls on the driving sensors of an autonomous robotic vehicle.

2. Procedures

2.1 Modeling the XUV

2.1.1 Bodies and Joints

Modeling of the XUV began by our creating the virtual “bodies” in DADS, which represent the physical rigid bodies of the modeled system. The individual bodies are given attributes that represent the physical parameters of the actual body. For example, a body is given the dimensions, mass, inertias, and centers of gravity of the physical body. A virtual body is then assigned a graphical geometry, developed from basic geometric shapes or from CAD part files, which is used to visually represent the actual body. The CAD geometries are formatted as stereo-lithography files for import into DADS. The DADS XUV model presently contains approximately 100 individual bodies, most of which were developed from the CAD drawings of the actual robotic XUV. Bodies representing added subsystems (e.g., the SSP) were developed from geometric shapes and then given properties based on a generic representation of that particular system. Modeling of the vehicle continues as bodies are developed by “connection” of the individual bodies in their proper orientation with the proper linear and angular movement constraints. The connection of bodies begins with the XUV frame (see Figure 3) as the most basic assembly or body to which all the other bodies are attached. Connection of bodies within DADS is by joint constraints. Joint constraints (e.g., bracket, cylindrical, revolute, translational, spherical, etc.) are used to connect the individual bodies together while allowing for relative movement, if any, between the two bodies. A bracket joint between two bodies is used to represent any fixed connection, such as a bolted or welded connection, that allows for no relative linear or angular movement. A “revolute” joint connects two bodies, allowing no relative linear motion but allowing for angular motion about a single axis. For example, a revolute joint is used to represent the connection between a wheel hub and a steering knuckle. A cylindrical joint is similar to a revolute joint but allows for an added degree of freedom, that is, the relative linear motion along the axis of rotation.

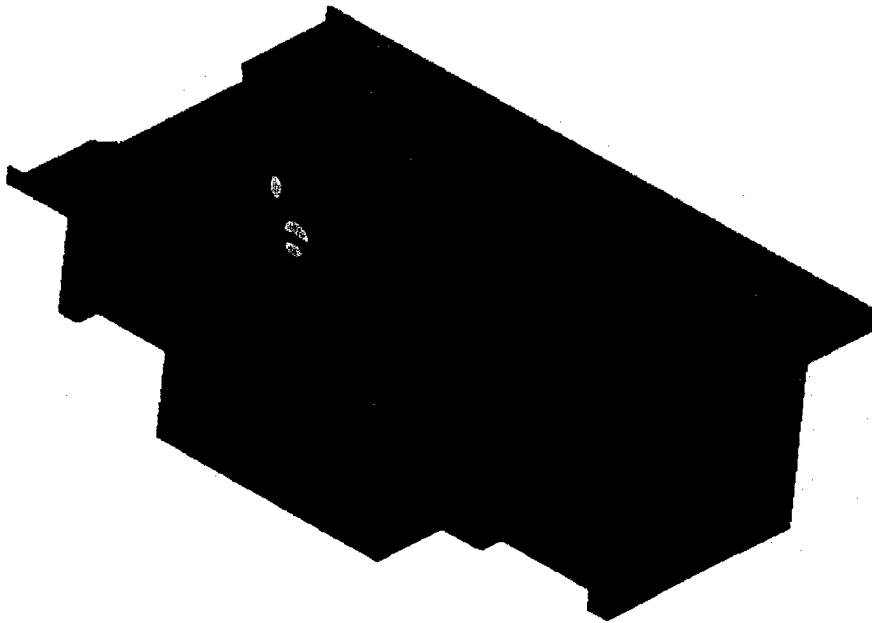

Figure 3. XUV frame.

A “translational” joint represents a connection between two bodies that allows for relative linear motion along a single axis but does not allow for any relative angular motion. An example of a translational joint would be the connection between a damper (shock absorber) rod and damper body. A spherical joint is a connection between two bodies that allows for angular motion about all three axes but allows for no relative linear motion. A physical example of a spherical joint connection would be a suspension ball joint or actual spherical joint in the vehicle’s control arm/steering knuckle assembly. Sub-assemblies are developed as joints connect and constrain bodies together. An example of one of the XUV’s sub-assemblies would be the steering-suspension sub-assembly. This particular sub-assembly contains 22 bodies and is connected by nine revolute joints, four bracket joints, three spherical joints, a single universal joint, and a single translational joint. The steering-suspension sub-assembly is shown in Figure 4. Completion of all joint connections between all the required individual bodies results in the generation of a set of dynamic equations describing the modeled system in a resting state. Adding motion to the model requires the addition of force, torque, and friction generators. These are added to the model through use of the DADS force elements, such as the translational spring damper actuator (TSDA), the rotational spring damper actuator, tire force models, friction force elements, and contact force elements.

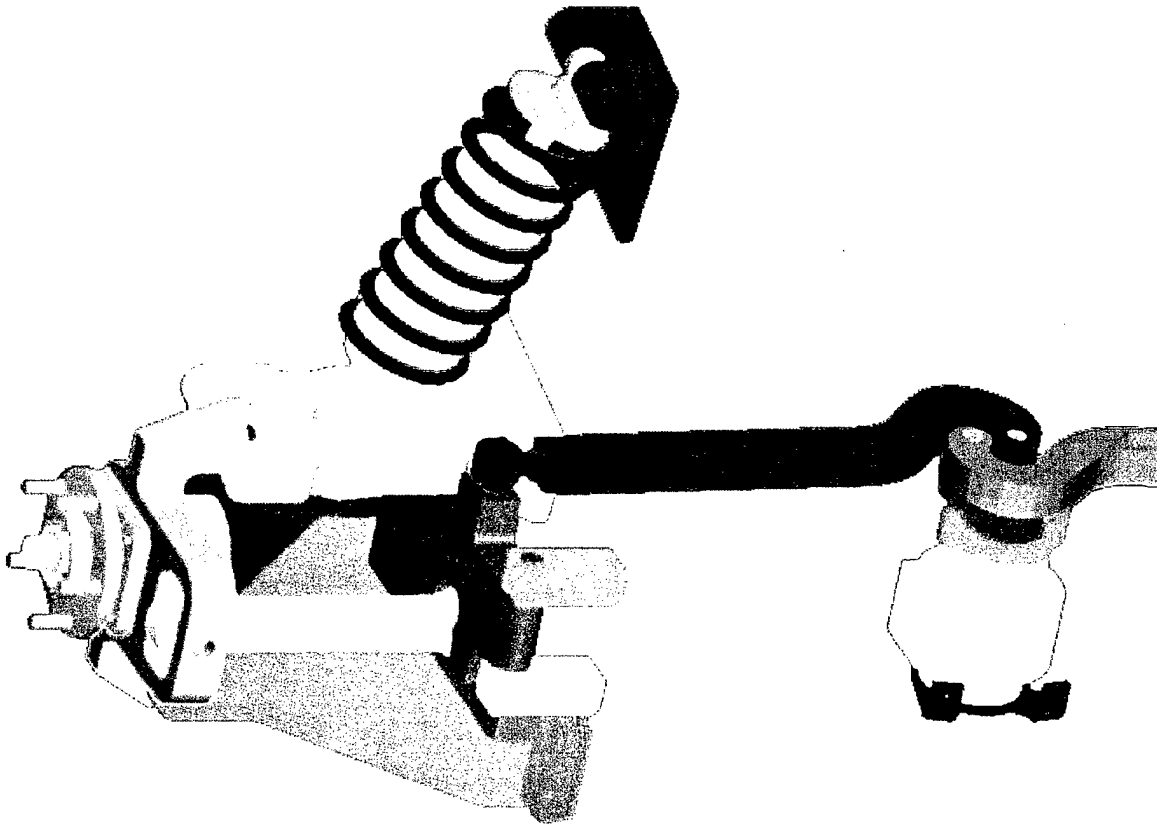

Figure 4. Steering suspension sub-assembly.

2.1.2 Forces and Torques

The addition of forces and torques to the collection of jointed bodies describing the robotic XUV gives the model its dynamic nature. The force elements used in the XUV model include the TSDA (used to model the vehicle's suspension springs and dampers), the tire force model (used to describe the forces developed at the vehicle's tire-ground contact points), the friction element (used to add friction to the vehicle's steering actuators), and the contact force element (used to model the vehicle's suspension jounce and rebound stops and to model the steering actuator stops). The TSDA element was used to model the spring and damper assemblies on the XUV model. Four TSDA elements were used, one for each spring and damper on the vehicle. Each TSDA was assigned particular connection points between the frame mount body and the upper control arm body. These points then define the geometric relationship of the force to the attached bodies. The TSDA is then assigned the actual spring length, spring constant (may be variable), damping coefficient and actuation force (if used as an actuator). The forces generated will then act between the points defined on the particular bodies.

DADS contains several tire force models. For the XUV model, the DADS simple tire force model was chosen because there were no detailed tire data for the robotic XUV. The simple tire

force model is a multi-point contact model that distributes the tire-terrain contact over a set of vertical “slices” through the tire cross section. One hundred slices or divisions was chosen to best represent the XUV’s tire characteristics, since it was typically to be used in the off-road environment where detailed micro-terrain requires a high degree of fidelity. The tire models, one for each of the vehicle’s four tires, were assigned parameters to match the tire’s physical characteristics. The assigned parameters are vertical stiffness (effective spring rate), vertical damping, frictional coefficient, rolling resistance, and cornering stiffness (lateral force generated per degree of slip angle). The tire data are listed in Table 1.

The DADS friction element was used to add friction to the vehicle’s steering actuators. These actuators represent the rotary hydraulic motors that are present in the actual robotic XUV steering system. Without the inclusion of friction in the steering system, small disturbances at the model’s tire-wheel assemblies would tend to deflect the steered wheels from their proper track. Friction in the actuator adds the needed resistance force to realistically represent the movement of the steering system when external deflecting forces are present. The friction element, which was applied to the actuator shaft body of the steering actuator, represents a form of bushing friction. The friction element is assigned values for static and dynamic friction coefficients, a threshold velocity, and dimensions of the virtual bushing for calculating the frictional resistance force.

The DADS contact element was used to model physical “hard” or contact stops within the vehicle. Examples of these are the right and left steering stops for the front and rear steering actuators and the jounce and rebound stops for each of the four suspension assemblies. The modeled steering actuators need to be limited to a certain degree of rotary travel to accurately represent the hydraulic steering motors in the robotic XUV. The actual hydraulic motors use a physical stop plate (steering stop) that is contacted by the pitman arm that is attached to the output shaft of the steering motor to limit rotary travel. In the modeled system, the steering actuator (hydraulic motor representation) rotates the steering actuator shaft body. A pitman arm body, which is attached to the steering actuator shaft body, swings through an arc and “contacts” a steering stop body. The pitman arm body and the steering stop body have an included contact element, which precludes them from occupying the same space at the same time. The contact element (a point-segment type) assigns a contact point to the pitman arm body and a contact segment or area to the steering stop body. The contact element generates compressive forces, based on the material properties assigned (Young’s modulus, coefficient of restitution), the geometric configuration of the point-segment pair and a threshold velocity for transitioning the forces. These contact forces are then generated whenever the two bodies have their point-segment pair within a defined proximity. The XUV model uses four contact elements to represent the four steering stops employed on the actual robotic vehicle. Figures 5 and 6 show the steering actuators, steering stops, and contact segments.

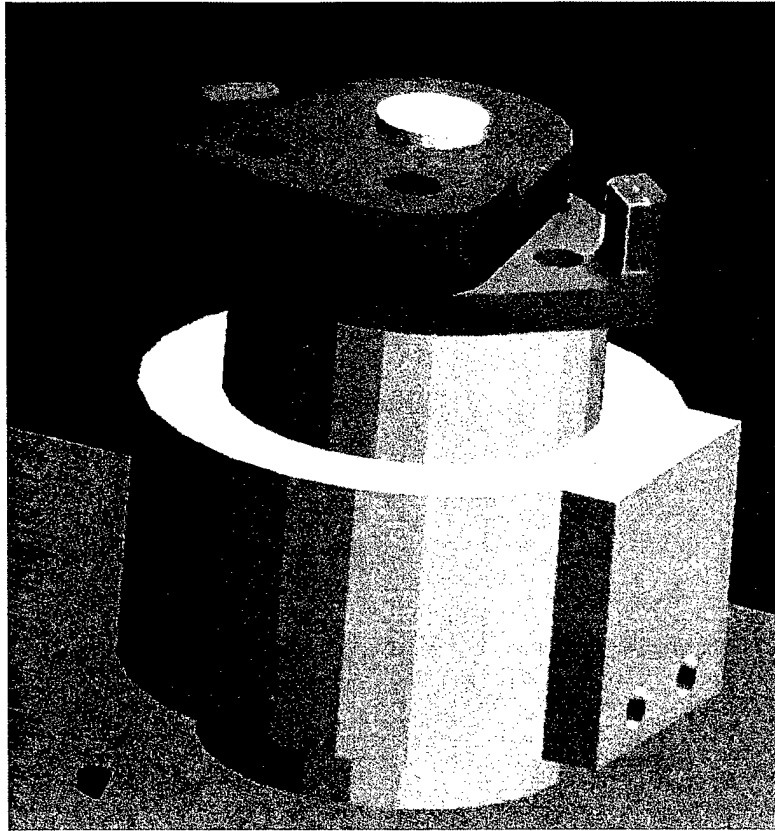

Figure 5. Steering actuator, contact segment visible.

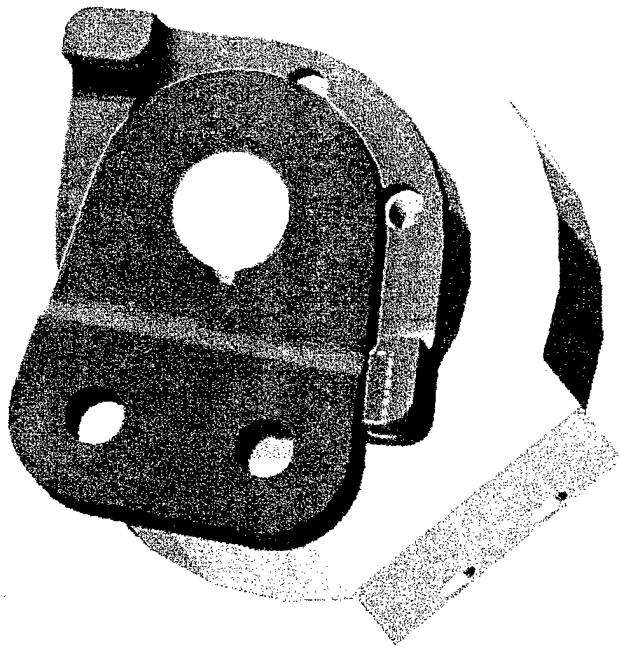

Figure 6. Steering actuator, pitman arm contacting segment.

Contact elements are also used in each of the four suspension assemblies. Each suspension assembly contains two contact elements within the damper body. The two contact elements are used to represent the jounce (compression) stop and the rebound (extension) stop of the assembly. The jounce stop is used to restrict wheel travel as the suspension spring is compressed upward toward the body, and the rebound stop is used to limit wheel travel as the spring decompresses toward its relaxed state. The rebound stop is set so that the stop is contacted before the spring fully decompresses to its relaxed state. This is done so that the spring always contains some pre-load force. The damper or shock body is assigned a contact point that will serve as a common point for both the jounce and rebound point-segment contact pairs. The jounce contact element assigns a contact segment to the corresponding shock cap body to create the jounce point-segment contact pair. The rebound contact element assigns a contact segment to the corresponding shock rod body to create the rebound point-segment contact pair.

Forces and torques are also used as drivers for certain subsystems. A torque curve or user-defined torque subroutine is used to apply torque to the vehicle's steering actuators, simulating hydraulically generated torque for steering the vehicle. The DADS user-defined force/torque subroutine (fr3512.f) is used as an interface to vehicle steering subroutines that are part of an autonomous driving software package (co-developed by the author), known as the Ground Vehicle Dynamics Model (GVDM). The GVDM provides the autonomous control and required steering torques to steer the XUV model around obstacles in the virtual terrain. Torque curves are also applied to the four individual wheels (bodies) to provide forward motion, while those torques are controlled by the speed controller within the GVDM. Torques are employed as part of the SSP subsystem, in which the SSP controller applies compensating torque to the SSP elevation drive body to reject chassis base motion pitch disturbances for an inertially stabilized view from the sensor platform. The SSP controller is discussed in detail in a later section.

The chassis assembly with the frame body removed for clarity is shown in Figure 7. The same chassis assembly performing a four-wheel steering maneuver is shown in Figure 8. The complete chassis assembly is shown in Figure 9.

2.1.3 XUV Chassis-Suspension Data and Parameters

GDRS supplied most of the engineering data and vehicle parameters for the XUV. Data about certain subsystems and components, such as dampers (shock absorbers) and tires, were acquired from the component manufacturers. Information about the characteristics of the XUV's tires was supplied by the tire manufacturer. The manufacturer was able to supply data about the tire's spring rate, but no information was available about the tire's damping characteristics. Therefore, a standardized value, acquired from Tank-Automotive and Armaments Command, was used within the XUV tire models instead. GDRS supplied detailed engineering information pertaining to the design of the XUV, such as physical placement of spring and damper assemblies, lengths of control arms, and turning angle of the wheels. Because of the limited availability of the vehicle, no static testing was performed on the XUV to determine its physical characteristics. All

the physical characteristics of the XUV were provided by GDRS. These data are shown in Table 1.

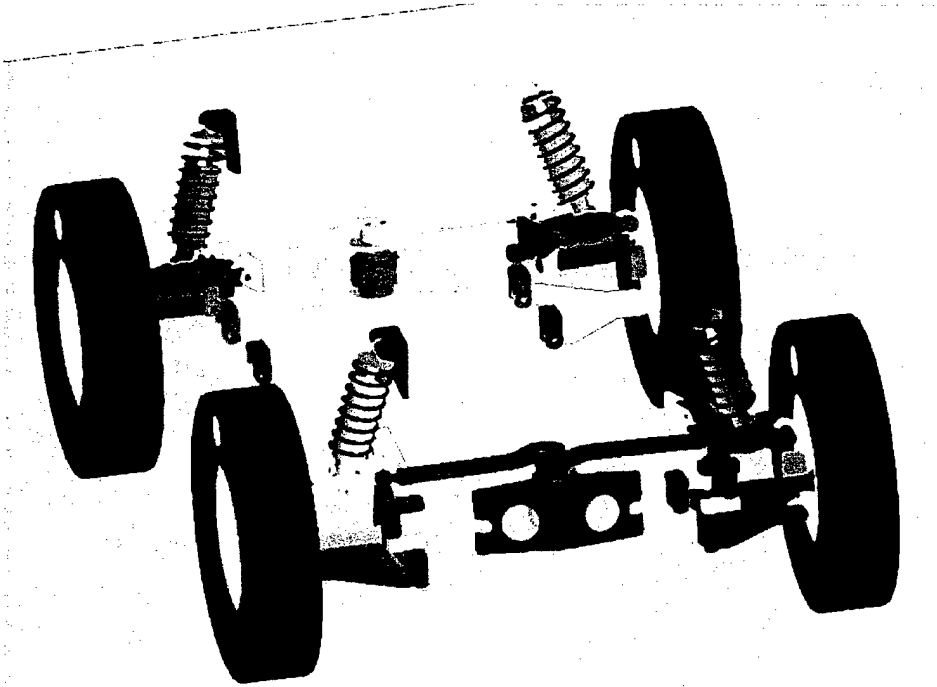

Figure 7. XUV chassis, frame removed.

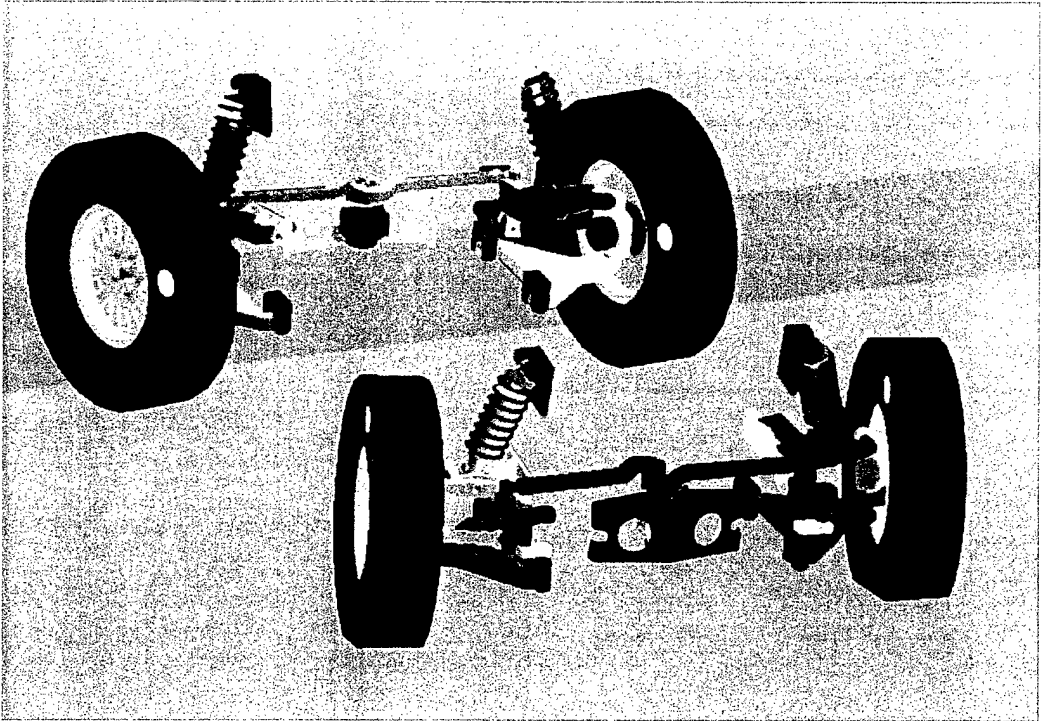

Figure 8. XUV chassis, four-wheel steering.

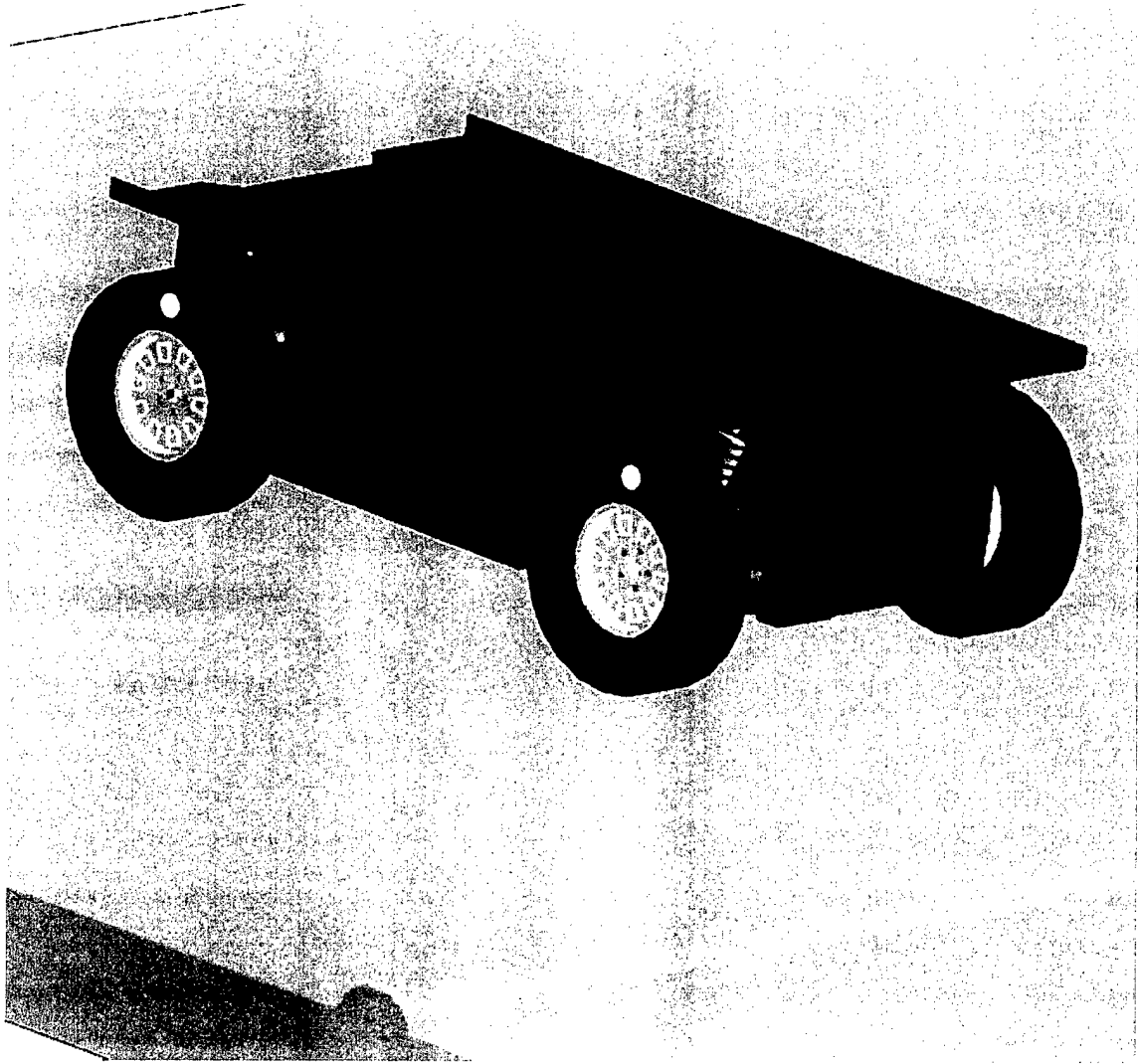

Figure 9. XUV complete chassis assembly.

The final addition to the basic XUV model was the inclusion of the CAD-generated stereo lithography file of the vehicle's outer hull. This outer hull file was imported into DADS and assigned to a "bodywork" body, which was given the appropriate dimensions and mass properties representing the characteristics of the vehicle's outer structure. The completed XUV model is shown in Figure 10.

Table 1. XUV physical characteristics

Parameter	XUV	Unit
Roll Moment of Inertia	230	Slug-ft ²
Yaw Moment of Inertia	707	Slug-ft ²
Pitch Moment of Inertia	558	Slug-ft ²
Curb Weight	3000	Pound
Unsprung Mass	9.94	Slugs
Vertical Center of Gravity	20.0	Inches, above ground level.
Lateral Center of Gravity	0.0	Inches, to right of vehicle center line.
Longitudinal Center of Gravity	34.7	Inches, forward of rear axle center line.
Length of Body	110.0	Inches
Width of Body	65.8	Inches
Height of Body	42.0	Inches
Length of Wheelbase	74.0	Inches
Width of Track	56.0	Inches
Front Weight Bias	47	Percent
Rear Weight Bias	53	Percent
Spring Stiffness, front	500	Pounds/inch
Spring Stiffness, rear	600	Pounds/inch
Damping Coefficient, front	125	Pounds*sec/inch
Damping Coefficient, rear	150	Pounds*sec/inch
Tire Vertical Stiffness	1500	Pounds/inch
Tire Damping Coefficient	50	Pound-sec/ft
Tire Cornering Stiffness	1500	Pounds/radian
Tire Frictional Coefficient	0.8	Rubber/Dry pavement
Tire Rolling Resistance	0.1	Percent of Normal Load

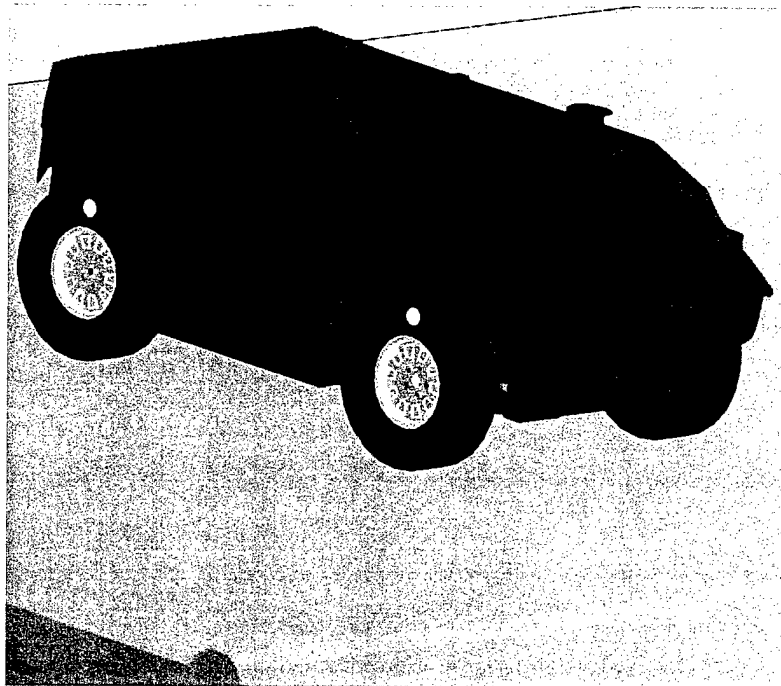

Figure 10. XUV model.

2.2 Modeling the SSP

The SSP model was developed as a subsystem model added to the XUV model. The intent of the SSP model was to develop a tool to evaluate the effects of inertially stabilizing the driving sensors of an autonomous robotic vehicle. The focus of this section of the report is to describe the modeling approach and to analyze the stabilization performance of the SSP controller. The SSP model, as of the date of this report, has not been used to evaluate the performance benefits of inertially stabilizing a driving camera system on board an autonomous robotic vehicle. When a vehicle traverses terrain, especially off-road terrain, pitch motions are induced into the vehicle's chassis because of irregularities in the surface. These motions, which tend to increase with greater speed, can create difficulties for the driving sensors used for autonomous navigation of robotic vehicles. In particular, increased vehicle chassis pitch rate can produce image blurring in a driving camera system, which necessitates slowing of the vehicle in an effort to eliminate this problem of "blurred vision". Inertial stabilization of the sensor platform strives to reject as much of the base (chassis) motion disturbance (pitch rate) as possible by sensing chassis pitch motion and actively driving the sensor platform in opposition to effectively cancel the pitch motion. The sensor platform would tend to stay on a fixed inertial reference as the vehicle chassis pitches. Because of the stabilization, autonomous vehicle speeds can be increased when the vehicles traverse pitch-inducing terrain because the sensing camera is isolated from the high pitch rates that cause image blurring.

Development of the SSP model was based on an algorithm from the Combat Vehicle Engineering Simulation (CVES) for a pitch-stabilized sighting system from an M1A1 Abrams MBT. The algorithm was modified for use with small vehicle platforms and extended to include the roll and yaw axes. The control algorithm was modeled within MatrixX, a commercial off-the-shelf (COTS) control design software package, to adjust and tune the controller for the particular needs of stabilizing a sensor platform mounted on board a small off-road vehicle. In particular, the goals were to reject pitch rate amplitudes as great as 200 degrees per second with a frequency content below 10 Hz. These values include the range of pitch rate amplitudes and frequencies that would likely be encountered by a small vehicle in the off-road environment. Physical parameters were based on a generic platform and sensor hardware of the type and size typically used on board small robotic vehicles. The control parameters were chosen and then adjusted to achieve the stated performance goals, based on frequency analyses. The control flow diagram is shown in Figure 11; the frequency analysis gain plot is shown in Figure 12.

The basic signal flow for the SSP controller can be seen in Figure 11 where a base disturbance (chassis pitch rate) is differenced with the inertial rate (platform pitch rate) to generate a relative rate. This relative rate, which is sensed by a rate tachometer mounted between the sensor platform and the chassis, is fed back and summed with the platform inertial rate. The platform inertial rate is sensed by a platform-mounted gyroscope. This combined feedback rate is fed to a motor dynamics model which then generates a motor armature current and thus, a motor output torque. The motor torque is then fed to a platform load dynamics model to generate a platform

angular acceleration. The platform angular acceleration is numerically integrated to generate the platform angular rate (platform inertial pitch rate). The goal is to make the platform inertial pitch rate approach zero by generating motor torques to drive the sensor platform at a rate that is similar to the chassis pitch rate but is 180 degrees out of phase.

Continuous SuperBlock Pitch Stabilized Platform Inputs 0 Outputs 2

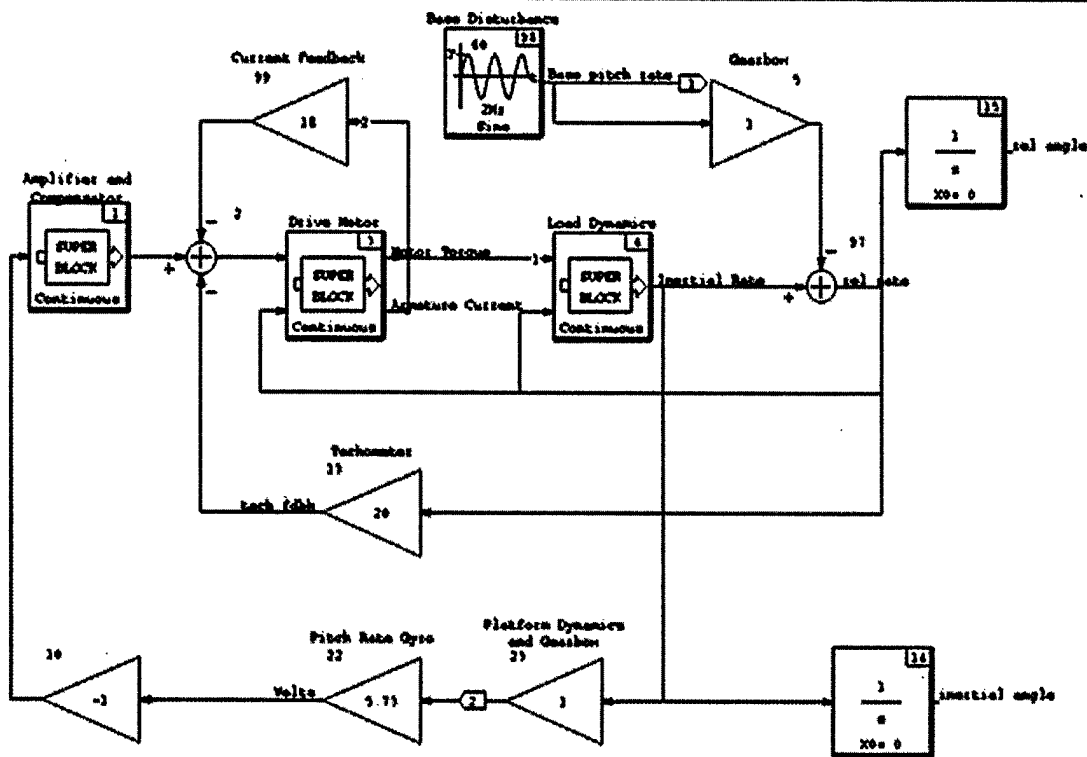

Figure 11. SSP control flow diagram.

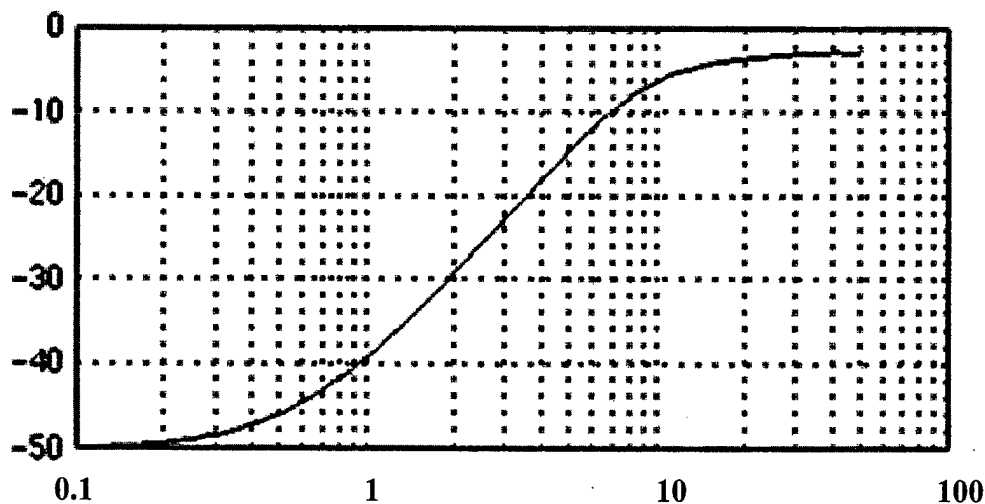

Figure 12. Platform gain plot.

When we examine the gain plot in Figure 12, it is clear that the effectiveness of the controller for rejecting base motion disturbance is highly frequency dependent. The goal during the frequency analysis was to have the controller reject disturbances below 10 Hz. The plot shows the relative amount of signal reduction in decibel over the range of frequencies. As the pitch rate frequencies approach 100 Hz, the signal amplitude reduction approaches 0 dB or a gain value of unity. Frequencies of 10 Hz and below show a marked reduction in pitch rate signal amplitude. For example, at a pitch rate frequency of 7 Hz, the plot shows a decibel value of -10 or a signal gain of approximately one third. This shows that with an input pitch rate disturbance at a frequency of 7 Hz, the output platform pitch rate will be one-third the amplitude of the input. Looking at a pitch rate input disturbance at a frequency of 2 Hz, the plot shows a decibel value of -30 or a signal gain of approximately one thirtieth. This shows that the input pitch rate disturbance signal amplitude will be reduced to approximately one-thirtieth of its original amplitude before it propagates through to the sensor platform. Further, when we look at the gain plot, it is clear that the SSP controller is performing like a “high pass” signal filter, in which high frequency signals (disturbances) pass through with little or no amplitude reduction, and low frequency signals have their amplitudes highly attenuated.

Upon completion of the frequency analysis, a model of the SSP was built in DADS as an added subsystem. The bodies and geometries of the SSP are simple structures requiring only two major parts: the `platform_elevation_drive` and the `platform_azimuth_drive`. These bodies were then connected to each other by a joint constraint and to the XUV model bodywork. The major effort for the SSP was in developing the model of the platform controller. The controller was modeled directly in DADS with the internal control elements. The SSP controller uses 21 DADS control elements to model the stabilization network. A description of two of the SSP control elements will suffice for describing the method of modeling the controller. The description includes the motor armature model and the amplifier-compensator network model. The armature is modeled as a first order analog transfer function control element. The input signal to the armature is `voltage_to_armature` with a transfer function numerator that has a constant value of 0.75. The transfer function denominator has a first order coefficient value of 0.003 and a constant coefficient of 1.0. The output of the armature is `armature_current_output`. The amplifier-compensator network is modeled as a second order analog transfer function control element. The input signal to the amplifier-compensator is `gyro_input_to_amplifier_compensator`. The transfer function numerator has a second order coefficient of 0.0002039184, a first order coefficient of 0.02856, and a constant coefficient of 1.0. The transfer function denominator has a second order coefficient of 0.06411024, a first order coefficient of 0.5064, and a constant coefficient of 1.0. The amplifier-compensator output signal is simply `amplifier_compensator_output`. After they are modeled, the individual control elements have their input and output connected in a manner matching the signal flow of the controller diagram. The SSP model mounted to the XUV model is shown in Figure 13. The SSP model with simulated sensor cone traversing a virtual bump course is shown in Figure 14.

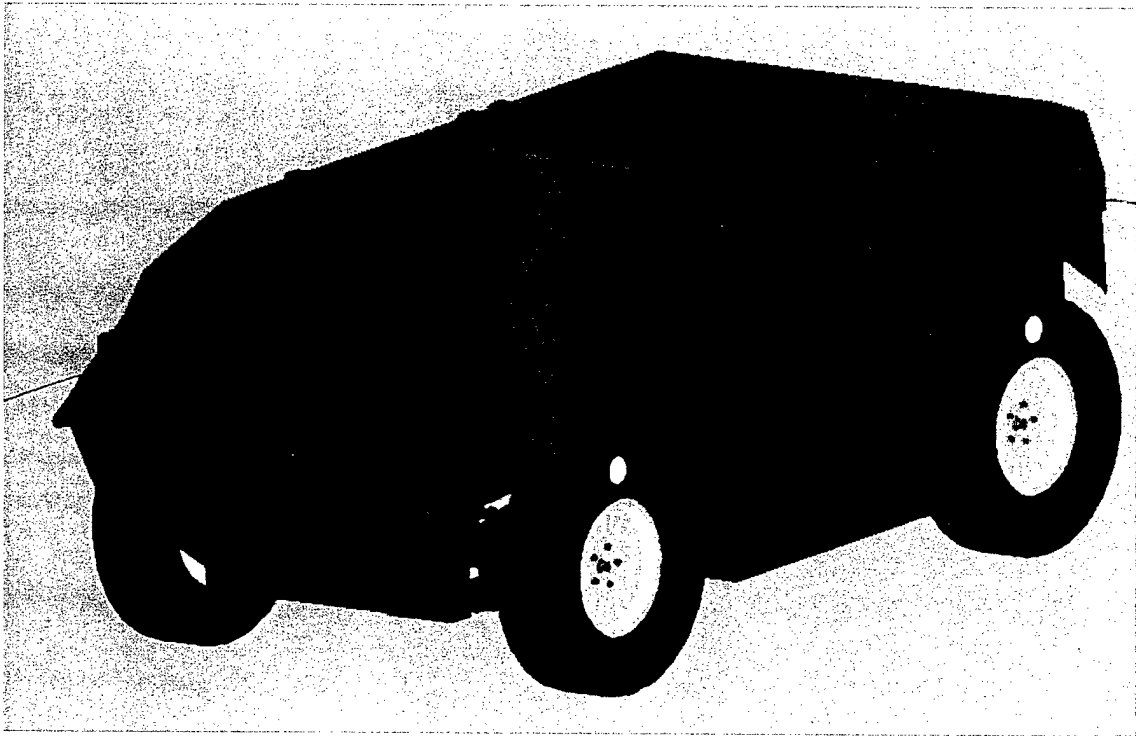

Figure 13. Stabilized sensor platform model on board the XUV model.

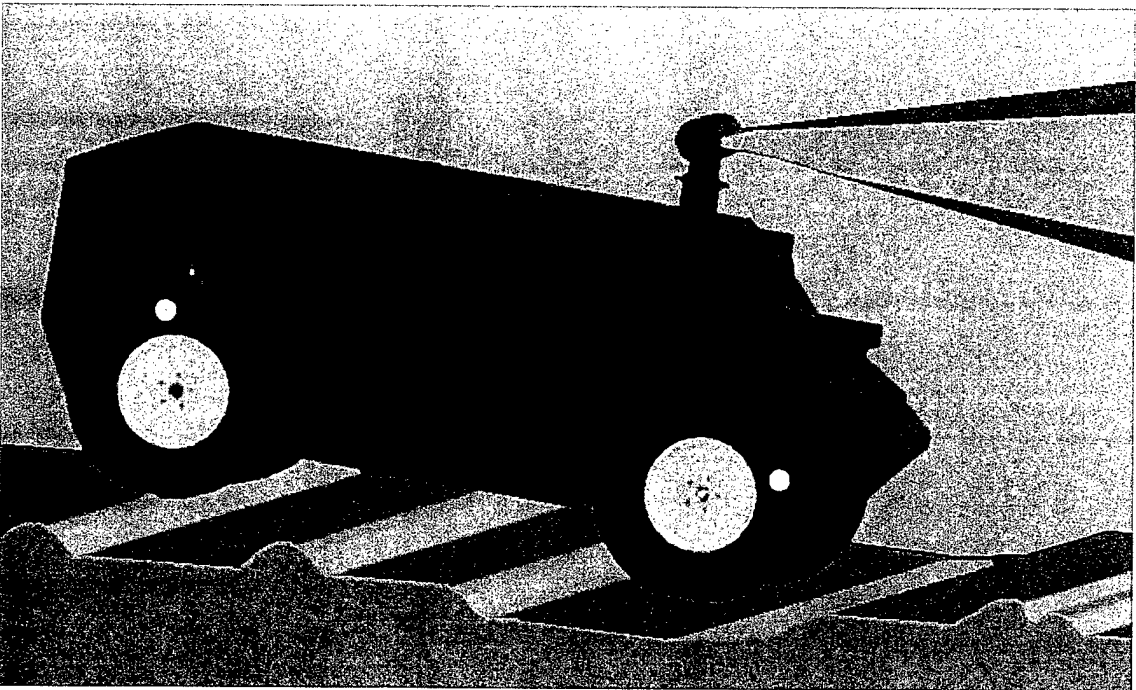

Figure 14. Stabilized sensor platform model with simulated sensor cone.

3. Discussion

Upon completion of the robotic XUV model and the SSP model, testing began to evaluate their ability to produce engineering output that would represent the characteristics and behavior of actual systems. We conducted testing by (a) developing virtual terrains that represented a generic off-road environment and parts of the Aberdeen Test Center's (ATC's) road shock and vibration course, (b) exercising the models on these terrains, and (c) collecting engineering data output from the models. The XUV model and the SSP model were exercised over various terrains at various speeds, and the pitch rates and vertical accelerations generated by the vehicle's chassis, wheels, and stabilized platform were collected and analyzed. The data collected about pitch rates and vertical accelerations for the vehicle model were consistent with values that would be expected to be generated from a small vehicle traversing off-road terrain. The robotic XUV, as of the date of this report, has not undergone any formal instrumented road shock and vibration testing. This lack of actual test data with which to compare the XUV model's virtual output precludes any scientific validation of the output generated by the vehicle model. When the robotic XUV is formally road shock and vibration tested and the test data are made available, then the robotic XUV model will be exercised in a manner that closely simulates the actual test scenarios, and the output data will be compared in an effort to validate the model. Until the opportunity to validate arises, the model's output can only be judged on the basis of its relative consistency with the output recorded from other vehicles of a similar type during similar conditions. As noted before, the engineering output for the vehicle model is consistent with actual output generated by small vehicles operating in an off-road environment. The chassis pitch rate of the XUV model while it traversed a generic off-road course with a varying bump amplitude and frequency is shown in Figure 15.

The chassis vertical acceleration of the XUV model for the same bump course is shown in Figure 16. The speed over this bump course ranged from zero (standing start) to approximately 20 mph.

Figure 17 shows the vertical acceleration of one the XUV model's component bodies, namely, the right front wheel, while it traversed the generic bump course.

The SSP model showed significant results in its ability to reject chassis base motion while the vehicle model traversed rough terrain. The pitch rates collected from the SSP model showed a trend consistent with the frequency analysis done on the SSP controller. The results show large reductions in pitch rate amplitude with low frequency terrain disturbance input and more modest reductions with higher frequency disturbances. The pitch rate of the stabilized sensor platform, while the XUV model traversed the generic bump course, is shown in Figure 18.

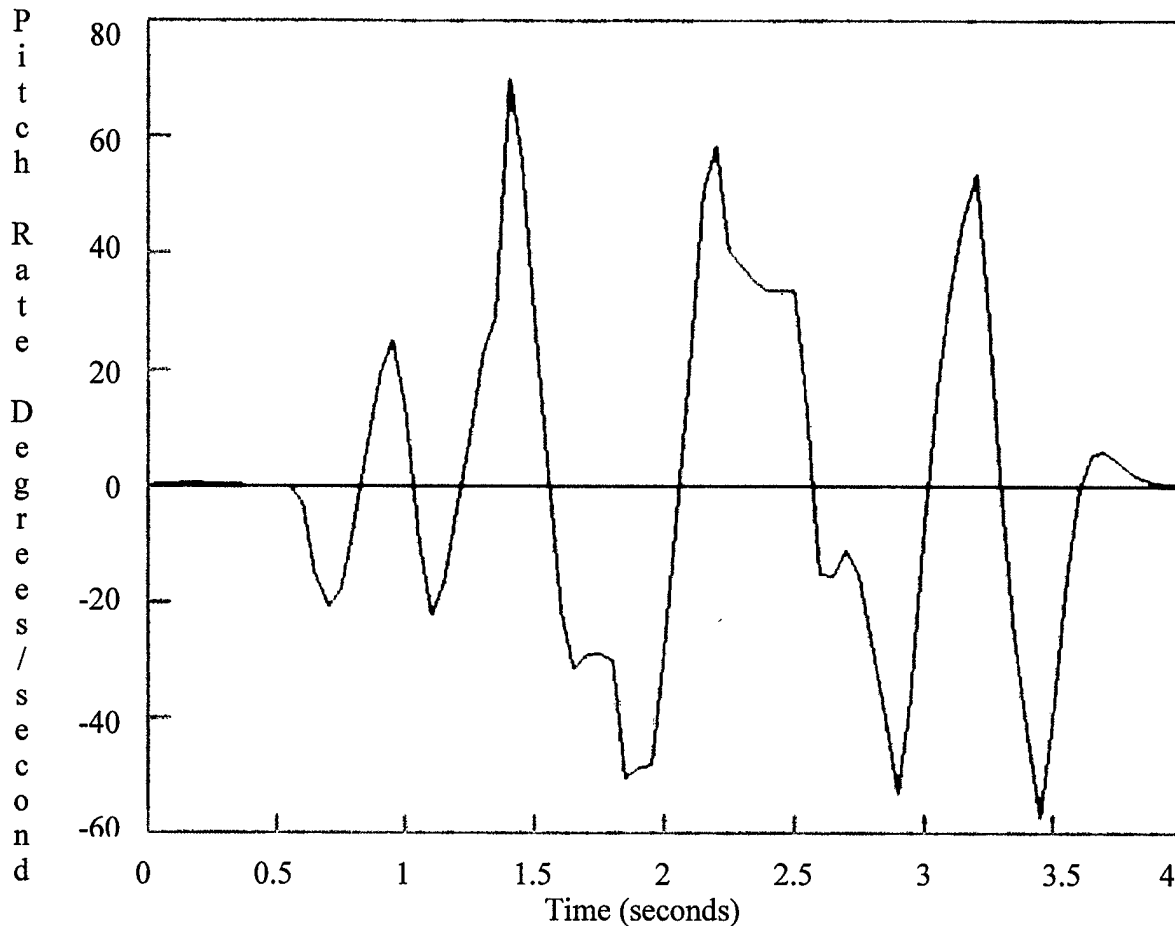

Figure 15. XUV chassis pitch rate, generic bump course.

A comparison between the pitch rate amplitudes of the XUV model chassis and of the SSP model platform shows that the SSP controller significantly reduces the level of pitch rate disturbance reaching the sensor platform. A pitch rate comparison between the XUV chassis and the sensor platform, while the XUV traversed the generic bump course, is shown in Figure 19.

The SSP controller removes most of the terrain-induced pitch disturbance as the model traverses the generic bump course. The terrain disturbance frequency propagated through the chassis is approximately 1.5 Hz; this input frequency lies in the range of frequencies where the SSP controller is very effective at attenuating the signal amplitude. Referring to Figure 12, the controller gain plot shows approximately -35 dB at 1.5 Hz or a gain value of 0.0178. This signal gain will reduce the output to less than one-fiftieth of the input, thus, greatly reducing the pitch rate at the sensor platform. Figure 20 shows a similar comparison of the pitch rates but with the vehicle model traversing a single 6-inch half-round bump at a speed of 15 mph.

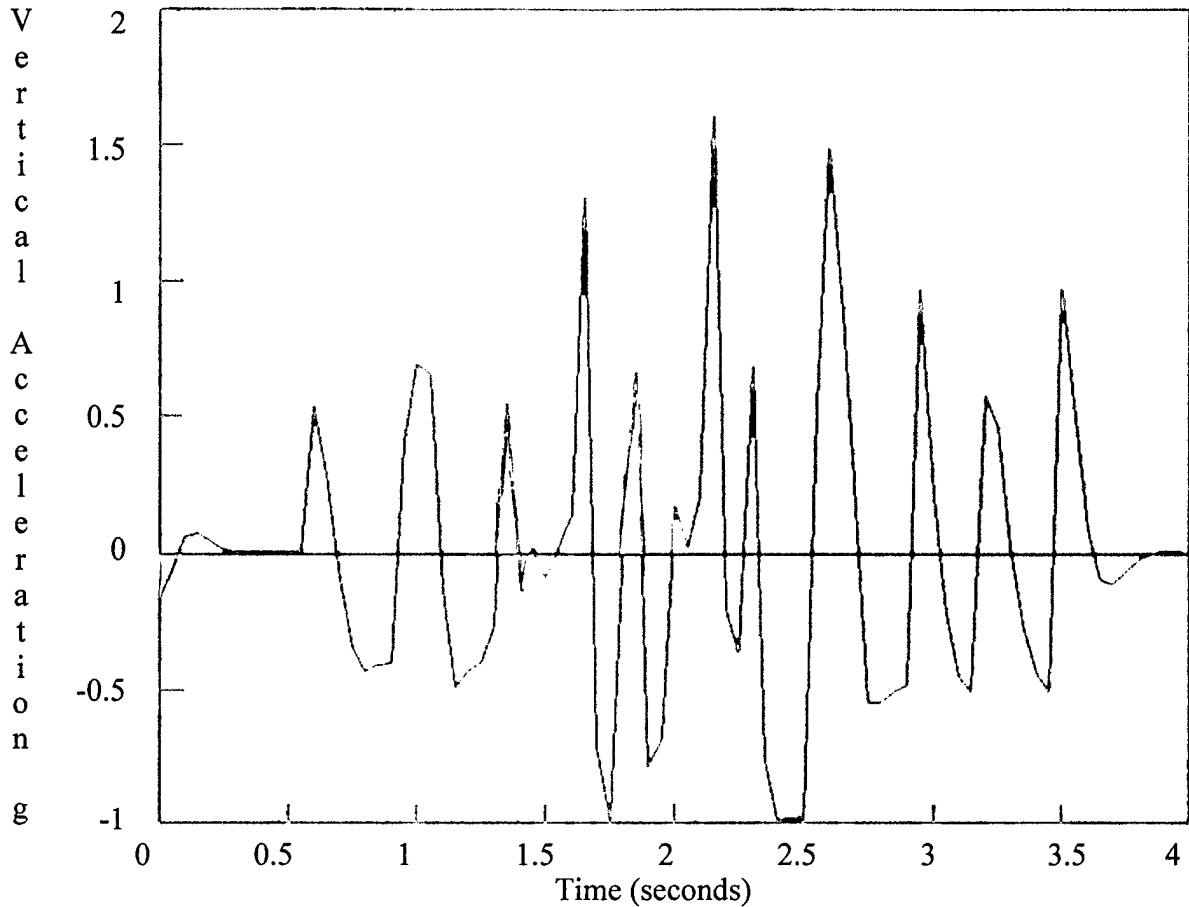

Figure 16. XUV chassis vertical acceleration, generic bump course.

Traversing the 6-inch half-round bump at 15 mph generates a terrain disturbance frequency of approximately 2 Hz, which has the controller operating in the range of approximately -30 dB for a gain of approximately 0.03. This terrain and speed scenario also lends itself well to significant reductions in pitch disturbance at the sensor platform. Certain terrain and speed combinations can lead to terrain disturbance frequencies that move into the range where the controller is not as capable of attenuating the signal amplitude. This frequency range tends to be above 7 Hz, where the controller generates larger gain values. One of the terrains used in the analysis was a model of the ATC 4-inch washboard course. The longitudinal cross section of the 4-inch washboard course can be described as a sinusoidal function with a 4-inch peak-to-peak amplitude and a wave length of 24 inches. A pitch rate comparison between the XUV chassis and the sensor platform, while the XUV traversed the 4-inch washboard course at a speed of 10 mph, is shown in Figure 21.

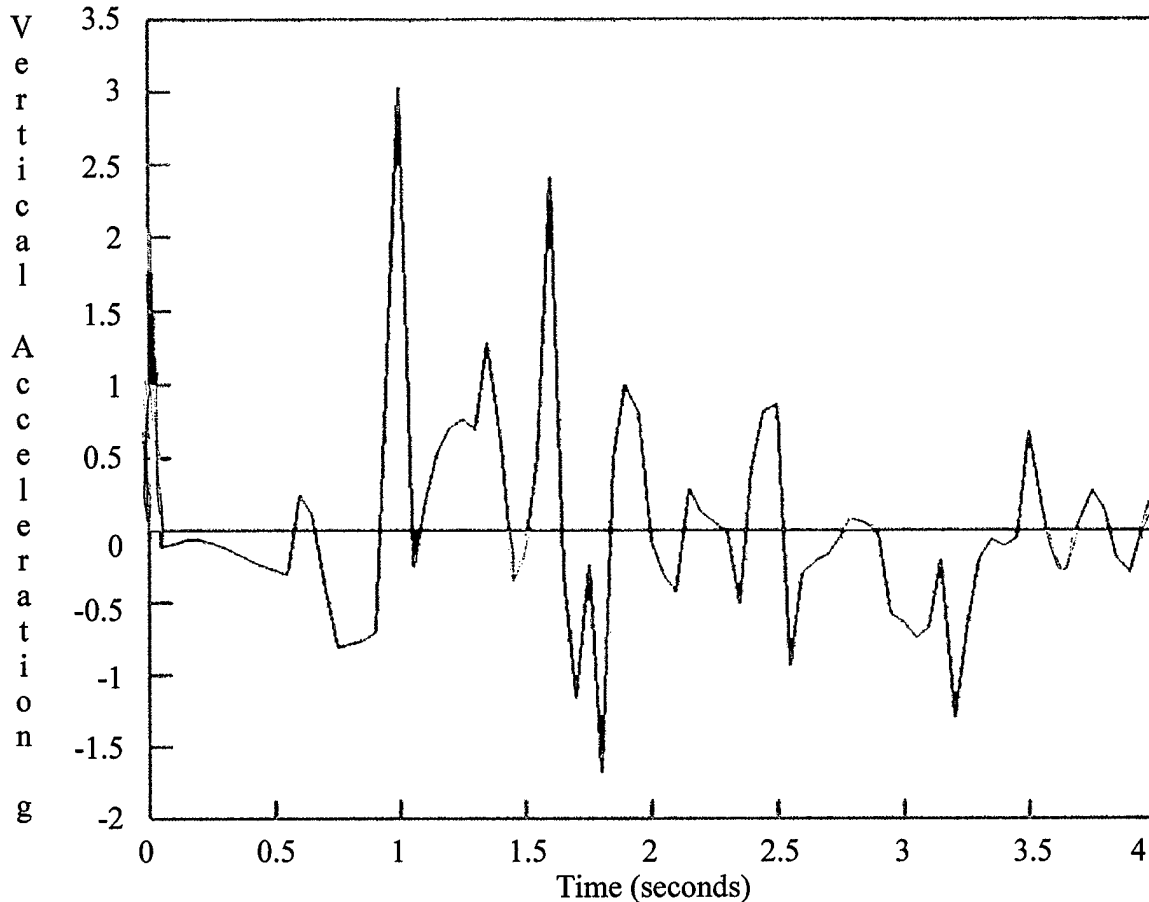

Figure 17. Right front wheel vertical acceleration, generic bump course.

Examining Figure 21, it is clear that the terrain-generated disturbance (chassis pitch rate amplitude) is not being attenuated nearly as significantly during this terrain traversal. The input terrain disturbance amplitude is relatively low, but the terrain disturbance frequency is considerably higher than on the previous terrains. Knowing that the terrain wave length is 24 inches and that the vehicle is traveling at 10 mph, which is approximately 15 feet per second, then the terrain disturbance frequency should be approximately 7.5 Hz. When we look at the figure, about 7.5 cycles exist over the 1-second time interval or a frequency of 7.5 Hz. Referring again to Figure 12, the platform gain plot, we see that at 7.5 Hz, the controller is in the range of only -8 dB or a gain of approximately 0.39. This indicates that at this higher frequency, the controller will only reduce the disturbance input to somewhat less than 40% of its original value. This 7.5-Hz signal is approaching the upper end of the frequency range for which the SSP controller was designed to suppress input disturbance. The SSP does a very good job of stabilizing the sensor platform for frequencies as great as 5 Hz, a fair job for frequencies over 5 Hz to 7.5 Hz, and provides little to no stabilization as frequencies approach 10 Hz. This is consistent with the initial frequency analysis of the controller and shows that the model performs the stabilization required by the original design specifications for signal attenuation below 10 Hz.

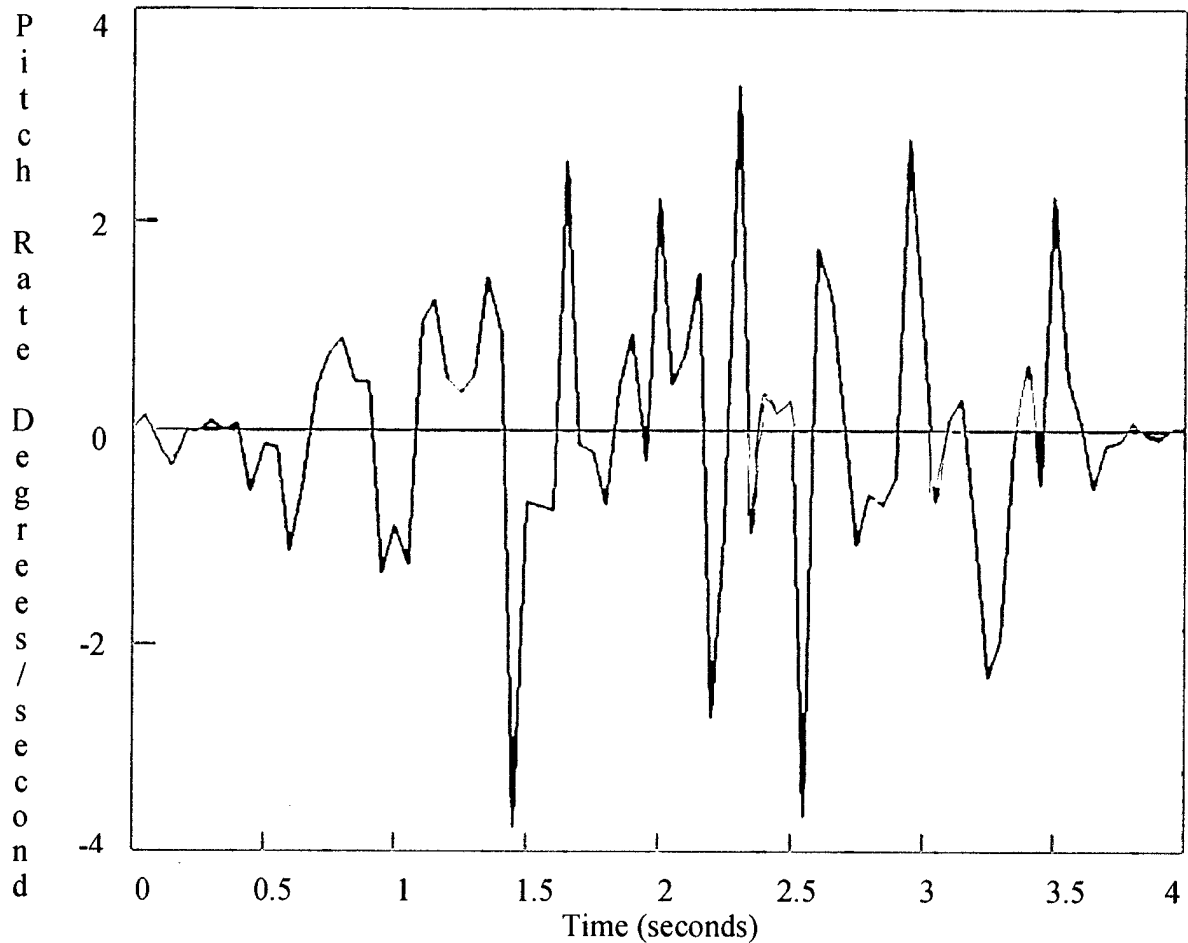

Figure 18. Stabilized sensor platform pitch rate, generic bump course.

4. Summary

The DADS XUV model was developed as a highly detailed multi-body engineering dynamics modeling tool for evaluating the performance of small robotic vehicles. The DADS XUV model is constructed with approximately 100 individual body elements, each of which is graphically represented by CAD-generated stereo lithography files. These stereo lithography files were imported into DADS to be used as the graphical geometries attached to the physical body elements. The individual body elements are connected to each other via DADS joint elements. The joint elements employed between individual bodies represent the form of attachment that exists between these parts in the actual vehicle. For example, a bolted or welded connection on the actual vehicle would be represented in DADS with a bracket joint connected between the two bodies. A bracket joint allows for no relative movement, linear or angular, to exist between the two bodies that it connects. Many forms of DADS joint elements were used in the building of the XUV model; these include bracket, revolute, planar, universal, and spherical joints. In total, 106

joint elements were used to represent the physical connections within the XUV. Upon completion, the XUV model was exercised over virtual terrains. These terrains were models of generic off-road courses and some of the ATC test courses. The ATC test courses modeled were the 4-inch washboard course and the 6-inch half-round bump course. Engineering data were collected from the XUV model as it traversed the test terrains at various speeds. The data collected were chassis pitch rates, chassis vertical accelerations, and wheel vertical accelerations. Since the robotic XUV has not undergone any formalized road shock or vibration testing, no actual test data were available to use as a comparison to the collected simulation data. The XUV model engineering data were evaluated by a relative comparison to engineering data output from vehicles of a similar type while they operated in an off-road environment. The XUV model's output compares favorably to data collected from other vehicles of this type while they traversed similar terrains. Until actual road shock and vibration test data from the robotic XUV become available, no thorough validation of the XUV model will be possible. It is recommended that static and dynamic tests be performed on the XUV to collect actual data to verify that the correct engineering parameters have been used within the model and to validate the performance of the simulation model.

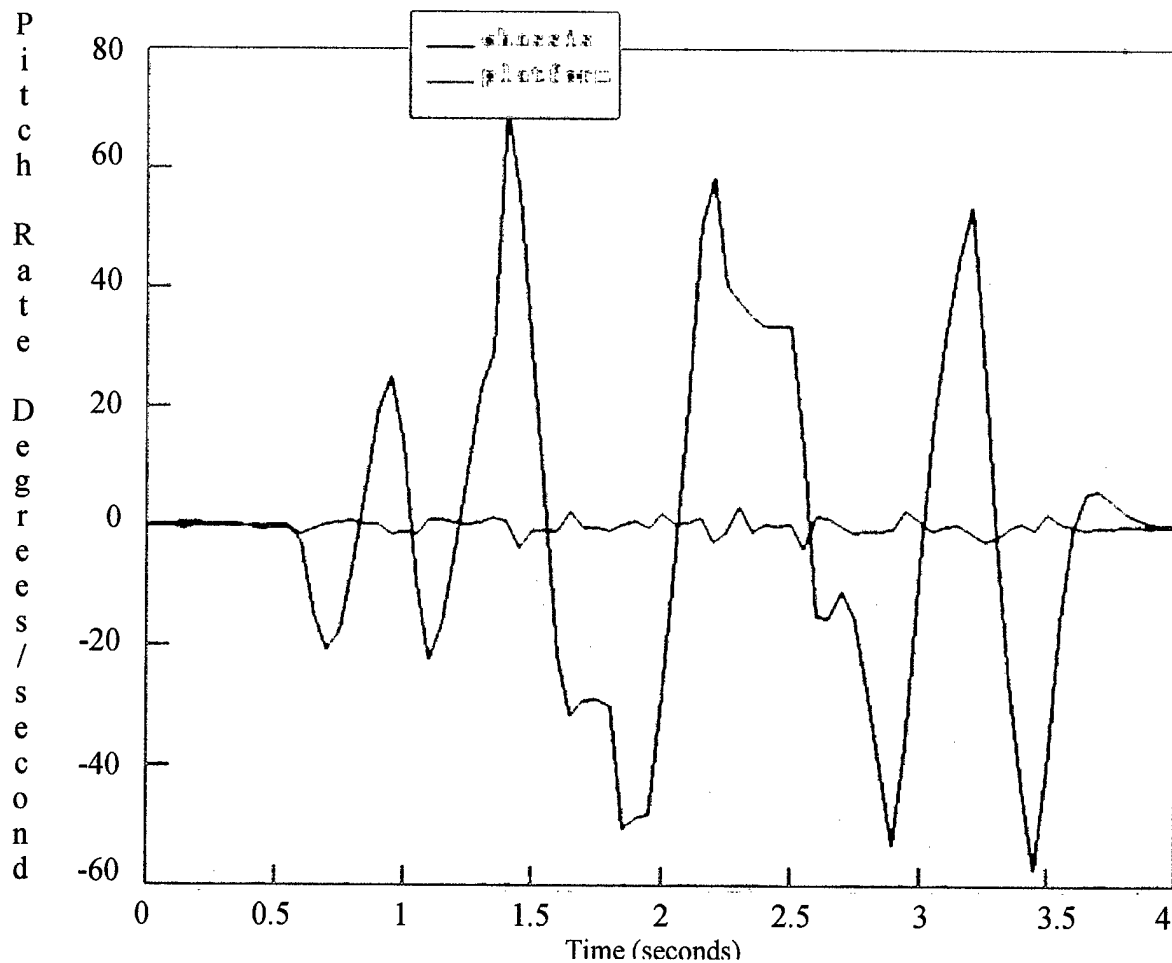

Figure 19. XUV chassis and sensor platform pitch rate, comparison 1.

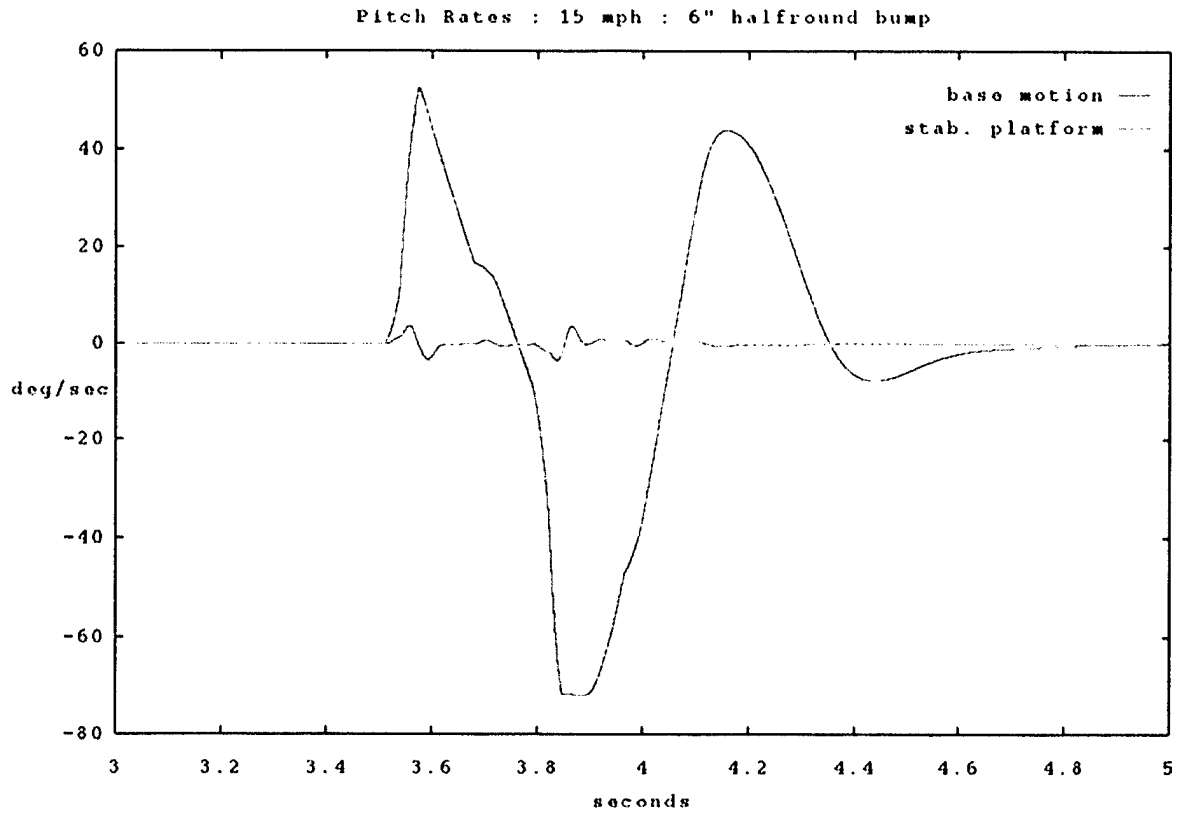

Figure 20. XUV chassis and sensor platform pitch rate, comparison 2.

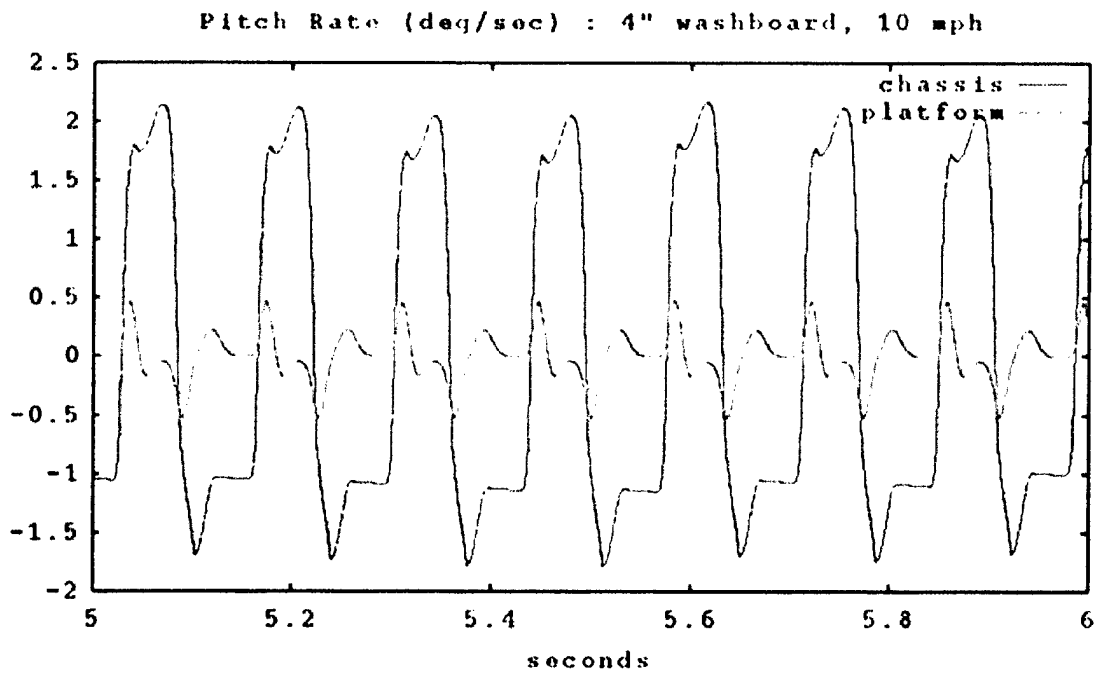

Figure 21. XUV chassis and sensor platform pitch rate, comparison 3.

The SSP model was developed as a tool to evaluate the benefits of inertially stabilizing the driving sensors of an autonomous robotic vehicle. This report describes the modeling approach and analyzes the stabilization performance of the SSP controller. The SSP model, as of the date of this report, has not been used to evaluate the performance benefits of inertially stabilizing a driving camera system on board an autonomous robotic vehicle. The SSP was originally developed from a CVES algorithm for a pitch-stabilized sighting system on an M1A1 Abrams MBT. The algorithm was modified for use with small vehicle platforms and extended to include the roll and yaw axes. The modified algorithm was then modeled within MatrixX, a COTS control design software package, to adjust and tune the parameters to meet the specifications for stabilizing a sensor package on board a small off-road vehicle. The specifications include the ability to reject base motion disturbance (chassis pitch rate) that is likely to be encountered by a small vehicle operating in the off-road environment. These likely disturbances are typically pitch rate amplitudes below 200 degrees per second with a frequency below 10 Hz. A frequency analysis was performed on the control algorithm in order to adjust the parameters to meet the required specifications. An SSP model and controller were then built in DADS as an added subsystem to the robotic XUV model. The XUV model and SSP model were subsequently exercised together over various terrains to examine the SSP's ability to reject chassis base motion disturbance. The results showed that the SSP did an excellent job of rejecting pitch disturbances at frequencies as great as 5 Hz, a fair job above 5 Hz to 7.5 Hz, and performed little to no rejection ability as disturbance frequencies approached 10 Hz. The SSP model results were consistent with the results of the frequency analysis, and thus, the required specifications for stabilization of a sensor platform on board a small vehicle operating in the off-road environment.

Bibliography

Corcoran, P.E., *Gunner Tracking Models for the BFVS-A3 Combat Vehicle Engineering Simulation*, ARL-TR-2588, U.S. Army Research Laboratory, Aberdeen Proving Ground, MD, November 2001.

Faller, J.G., and G.O. White, *The Effect on Acceleration Levels of Changing a HMMWV Computer Model Frame from a Rigid to a Flexible Body*, draft report, U.S. Army Aberdeen Test Center, Aberdeen Proving Ground, MD, undated.

Fazio, P.J., *A Comparison of the Mobile Detection Assessment Reconnaissance System (MDARS) and Experimental Unmanned Vehicle (XUV) Robotic Vehicle Models*, ARL-TR-2524, U.S. Army Research Laboratory, Aberdeen Proving Ground, MD, September 2001.

Perkins, T.R., and P.E. Corcoran, *MIAI Engineering Simulation for the Virtual Proving Ground: Description and User's Guide*, ARL-MR-360, U.S. Army Research Laboratory, Aberdeen Proving Ground, MD, May 1997.

REPORT DOCUMENTATION PAGE

Form Approved
OMB No. 0704-0188

Public reporting burden for this collection of information is estimated to average 1 hour per response, including the time for reviewing instructions, searching existing data sources, gathering and maintaining the data needed, and completing and reviewing the collection of information. Send comments regarding this burden estimate or any other aspect of this collection of information, including suggestions for reducing this burden, to Washington Headquarters Services, Directorate for Information Operations and Reports, 1215 Jefferson Davis Highway, Suite 1204, Arlington, VA 22202-4302, and to the Office of Management and Budget, Paperwork Reduction Project (0704-0188), Washington, DC 20503.

1. AGENCY USE ONLY (Leave blank)		2. REPORT DATE December 2002	3. REPORT TYPE AND DATES COVERED Final	
4. TITLE AND SUBTITLE Dynamic Analysis and Design System Modeling of the Experimental Unmanned Vehicle			5. FUNDING NUMBERS PR: 622618AH80	
6. AUTHOR(S) Fazio, P.J. (ARL)				
7. PERFORMING ORGANIZATION NAME(S) AND ADDRESS(ES) U.S. Army Research Laboratory Weapons & Materials Research Directorate Aberdeen Proving Ground, MD 21005-5066			8. PERFORMING ORGANIZATION REPORT NUMBER	
9. SPONSORING/MONITORING AGENCY NAME(S) AND ADDRESS(ES)			10. SPONSORING/MONITORING AGENCY REPORT NUMBER ARL-TR-2841	
11. SUPPLEMENTARY NOTES				
12a. DISTRIBUTION/AVAILABILITY STATEMENT Approved for public release; distribution is unlimited.			12b. DISTRIBUTION CODE	
13. ABSTRACT (Maximum 200 words) <p>The Weapons Analysis Branch, Ballistics and Weapons Concepts Division, Weapons and Materials Research Directorate, of the U.S. Army Research Laboratory built a multi-body engineering-level model of the unmanned ground vehicle platform used in the Office of the Secretary of Defense Demo III Robotics program during fiscal years 2000 and 2001. The vehicle platform used as the basis for the model was the experimental unmanned vehicle (XUV) developed and built by General Dynamics Robotic Systems (GDRS). The XUV is a four-wheeled, Ackerman-steered, all-wheel drive autonomous vehicle that is approximately 10 feet long, 5 feet wide, 4 feet high and has a curb weight of ~3000 pounds. The XUV uses a four-cylinder, 78-hp diesel engine powering a four-wheel hydraulic drive system. A computer model of the XUV was subsequently developed as a further extension of the modeling tools used for analyzing robotic vehicle off-highway mobility and chassis dynamics and to further enhance the fidelity of battlefield simulations in which these vehicles are employed. The XUV was modeled within the structure of the Dynamic Analysis and Design System (DADS) software. DADS is a multi-body engineering computer simulation tool that allows the user to model mechanical system dynamics and kinematics. The user enters the mechanical system data in the form of masses, forces, and constraints and then the software generates and solves the equations of motion describing the modeled system. A stabilized sensor platform (SSP) controller was also modeled with the DADS control elements, based on a modified algorithm for a pitch-stabilized sighting system from an Abrams M1A1 main battle tank (MBT). Creation of the DADS XUV model provided us with a tool to evaluate engineering level concepts down to the component level for small vehicle platforms. This component-level analysis provides the fidelity necessary to further enhance the realism of robotic vehicle models when they are used as entities in large battlefield simulations. Further, the inclusion of sub-models, such as the SSP, allows for evaluating the effects of stabilization controls on the driving sensors of an autonomous robotic vehicle.</p> <p>We evaluated the XUV model's performance by exercising the model over virtual test terrains that simulated a generic off-road environment and some of the Aberdeen Test Center's (ATC) road shock and vibration test courses. The data analyzed were chassis vertical accelerations, chassis pitch rates, and wheel vertical accelerations. Since the robotic XUV has not undergone any formal road shock and vibration testing, no actual test data were available for use in validation of the XUV model. The XUV model's performance was evaluated simply on the basis of a relative comparison to the performance of similar vehicles while they operated in an off-road environment.</p> <p>The SSP model was developed from an algorithm for a pitch-stabilized sighting system from an M1A1 Abrams MBT. The algorithm was modified for use in inertially stabilizing a driving sensor platform on board a small vehicle operating in an off-road environment. The SSP algorithm was analyzed and adjusted to reject base motion disturbances that were likely to be encountered by a small vehicle in the off-road environment. The targeted disturbances were chassis pitch rates below 200 degrees per second with a frequency below 10 Hz. The SSP model showed very good rejection of these disturbances while being exercised with the XUV model over virtual terrains.</p>				
14. SUBJECT TERMS blast loading military operations in urban terrain (MOUT) simulation modeling virtual simulation combat simulation real time modeling structural response			15. NUMBER OF PAGES 30	
			16. PRICE CODE	
17. SECURITY CLASSIFICATION OF REPORT Unclassified	18. SECURITY CLASSIFICATION OF THIS PAGE Unclassified	19. SECURITY CLASSIFICATION OF ABSTRACT Unclassified	20. LIMITATION OF ABSTRACT	