

AD _____

Award Number: DAMD17-98-1-8490

TITLE: Herpes Virus Therapy of Prostate Cancer

PRINCIPAL INVESTIGATOR: Robert L. Martuza, M.D.

CONTRACTING ORGANIZATION: Massachusetts General Hospital
Boston, Massachusetts 02114

REPORT DATE: August 2002

TYPE OF REPORT: Annual, Phase II

PREPARED FOR: U.S. Army Medical Research and Materiel Command
Fort Detrick, Maryland 21702-5012

DISTRIBUTION STATEMENT: Approved for Public Release;
Distribution Unlimited

The views, opinions and/or findings contained in this report are those of the author(s) and should not be construed as an official Department of the Army position, policy or decision unless so designated by other documentation.

20030220 091

REPORT DOCUMENTATION PAGE

Form Approved
OMB No. 074-0188

Public reporting burden for this collection of information is estimated to average 1 hour per response, including the time for reviewing instructions, searching existing data sources, gathering and maintaining the data needed, and completing and reviewing this collection of information. Send comments regarding this burden estimate or any other aspect of this collection of information, including suggestions for reducing this burden to Washington Headquarters Services, Directorate for Information Operations and Reports, 1215 Jefferson Davis Highway, Suite 1204, Arlington, VA 22202-4302, and to the Office of Management and Budget, Paperwork Reduction Project (0704-0188), Washington, DC 20503

1. AGENCY USE ONLY (Leave blank)		2. REPORT DATE August 2002	3. REPORT TYPE AND DATES COVERED Annual, Phase II (1 Aug 01 - 31 Jul 02)	
4. TITLE AND SUBTITLE Herpes Virus Therapy of Prostate Cancer			5. FUNDING NUMBERS DAMD17-98-1-8490	
6. AUTHOR(S) Robert L. Martuza, M.D.				
7. PERFORMING ORGANIZATION NAME(S) AND ADDRESS(ES) Massachusetts General Hospital Boston, Massachusetts 02114 E-Mail: rmartuza@partners.org			8. PERFORMING ORGANIZATION REPORT NUMBER	
9. SPONSORING / MONITORING AGENCY NAME(S) AND ADDRESS(ES) U.S. Army Medical Research and Materiel Command Fort Detrick, Maryland 21702-5012			10. SPONSORING / MONITORING AGENCY REPORT NUMBER	
11. SUPPLEMENTARY NOTES Original contains color plates. All DTIC reproductions will be in black and white.				
12a. DISTRIBUTION / AVAILABILITY STATEMENT Approved for Public Release; Distribution Unlimited				12b. DISTRIBUTION CODE
13. Abstract (Maximum 200 Words) (abstract should contain no proprietary or confidential information) Conditionally replicating herpes vectors offer unique advantages for cancer therapy. We have studied vector constructs with increased anti-tumor efficacy and demonstrated that the NV-series of vectors are more efficacious in the mouse prostate cancer models than the G-series of vectors. Moreover, in a bilateral tumor model, the IL-12 containing vector, NV1042, causes a markedly significant tumor growth inhibition of the treated tumor and lesser but significant inhibition of the untreated tumor as well. Further, in studies of systemic administration, we found that NV 1023 and NV1042 can be administered safely intravenously in mice and that G207, NV1023, and NV1042 show efficacy after intravenous administration in a mouse Tramp model system. This work for the first time demonstrates that two different transgenic systems can be used to study efficacy of herpes oncolytic vectors. This will allow us to then study these vectors in the tumors occurring in situ in these transgenic animals and also will allow us to study improvements in these vector systems which we expect to ultimately translate into clinical trials.				
14. SUBJECT TERMS prostate cancer, herpes virus therapy, NV1042			15. NUMBER OF PAGES 10	
			16. PRICE CODE	
17. SECURITY CLASSIFICATION OF REPORT Unclassified	18. SECURITY CLASSIFICATION OF THIS PAGE Unclassified	19. SECURITY CLASSIFICATION OF ABSTRACT Unclassified	20. LIMITATION OF ABSTRACT Unlimited	

Table of Contents

Cover	1
SF 298	2
Table of Contents	3
Introduction	4
Body	4-10
Key Research Accomplishments	10
Reportable Outcomes	10
Conclusions	10
References	10
Appendices	10

ANNUAL PROGRESS REPORT FOR AWARD DAMD17-98-1-8490

ROBERT L. MARTUZA, M.D. "*Herpes virus therapy of prostate cancer*"

INTRODUCTION: Our goals remain the same as those outlined in the original grant proposal where we stated that if Phase II of this grant process is funded, we expect these studies to lead to improved vector design for local prostate cancer therapy and for systemic therapy for metastatic prostate cancer using oncolytic herpes vectors. Since the awarding of this grant one year ago, we have made significant progress in several of the areas detailed in our original hypotheses and statement of work and have met or exceeded our timetable for these twelve months:

BODY:

STATEMENT OF WORK, EXPECTATIONS AND TIMETABLE:

HYPOTHESIS 1. The efficacy of intravenous administration of herpes vectors for metastatic prostate cancer can be improved with the use of other HSV vectors and part of the efficacy may be due to selective injury of tumor vasculature:

- The *in vitro* testing of prostate cell lines for oncolysis by G207, G47 Δ , NV1020, NV1023 will be completed within 12 months.
- The *in vivo* testing of G207 and the best of the above vectors as determined from the *in vitro* studies should be completed by the end of 15 months.
- *In vivo* testing of multiple dosing strategies will be completed in athymic mice by the end of 12 months.
- *In vivo* testing in the TRAMP model will be completed by the end of 18 months.
- *In vitro* HuVEC studies will be finished by the end of 18 months.
- *In vivo* studies of effects on vasculature and associated histology studies will be finished by 22 months.
- Hypothesis 1 is estimated to require 160 C57Bl/6 mice and 40 athymic mice.

HYPOTHESIS 2. HSV therapy may beneficially interact with commonly-used partially-effective chemotherapy agents.

- Studies in seropositive animals will be completed by the end of 18 months.
- Studies assessing the possible effects of dexamethasone or cyclophosphamide will be completed by 21 months.
- Studies involving cisplatin and HSV will be completed by 24 months.
- Hypothesis 2 is estimated to require 240 C57Bl/6 mice.

HYPOTHESIS 3. HSV vectors expressing soluble B7-1 and/or cytokines can stimulate systemic antitumor immunity effective against distant tumors.

- *In vivo* testing of dvB7lg/G207 and/or dvL12/G207 will be completed within 12 months.
- *In vivo* testing of systemic administration of various immunomodulatory factors in combination with the dvB7lg/G207 therapy will be completed by the end 21 months.
- *In vivo* testing of combining *gpt* suicide gene therapy with the dvB7lg/G207 therapy will be completed by the end of 21 months.
- Generation of dvB7lg using, as a helper virus, HSV with higher oncolytic activity than G207, and its *in vivo* testing will be completed by 24 months.
- Hypothesis 3 is estimated to require 360 C57Bl/6 mice.

PROGRESS IN THE FIRST YEAR OF THIS GRANT:

In order to explore the two complementary strategies of intravenous vector delivery (**Hypothesis 1**) and immune-based vector strategies (**Hypothesis 3**), it would be best to use immune competent animals and ideally study spontaneously arising tumors as are found in transgenic animals. This is important for both the intravenous delivery studies as well as for the immune strategies. For the immune-based strategies, a competent immune system is essential. However, even for the studies of intravascular delivery, studying vector performance in immune competent animals is important because an active immune system could theoretically impair delivery of the vector to the tumor or inhibit its intratumoral spread. Therefore, we have used transgenic animals that have recently been made available in preference over athymic mice for the *in vivo* testing of the multiple vectors and for the testing of the multiple dosing strategies as noted in Hypothesis 1. We have available in our laboratory two transgenic models: TRAMP and FVB/N C3(1) Tag mice. Male mice of these transgenics develop prostate cancer spontaneously and its progression closely mimics human prostate cancer. Prostate cancer cell lines, TRAMP-C2 and Pr14-2 established from the TRAMP or C3(1) mice respectively form tumors in syngeneic mice when implanted subcutaneously. We have conducted preliminary studies using TRAMP-C2 cells in C57BL/6 mice and Pr-14-2 cells in FVB/N mice with the ultimate goal of using the data obtained to study spontaneously arising tumors in each of these transgenic models. We recognize that human HSV-1 is known to replicate poorly in many rodent cells, nonetheless, we felt that studies in such a model system would be important to further vector development and use.

We have tested four HSV mutant vectors other than G207, namely G47Δ, NV1023, NV1034 and NV1042 in the above mouse prostate cancer cell lines. All the viruses are derived from strain F and carry mutations aimed at improving efficacy while maintaining safety. G47Δ is G207 with an additional deletion in the US11/ICP47 region resulting in increased replication in tumor cells and a blunting of the MHC1 down regulation that normally accompanies HSV infection. The following is the schema of G47Δ:

FIGURE 1: Structure of G47Δ

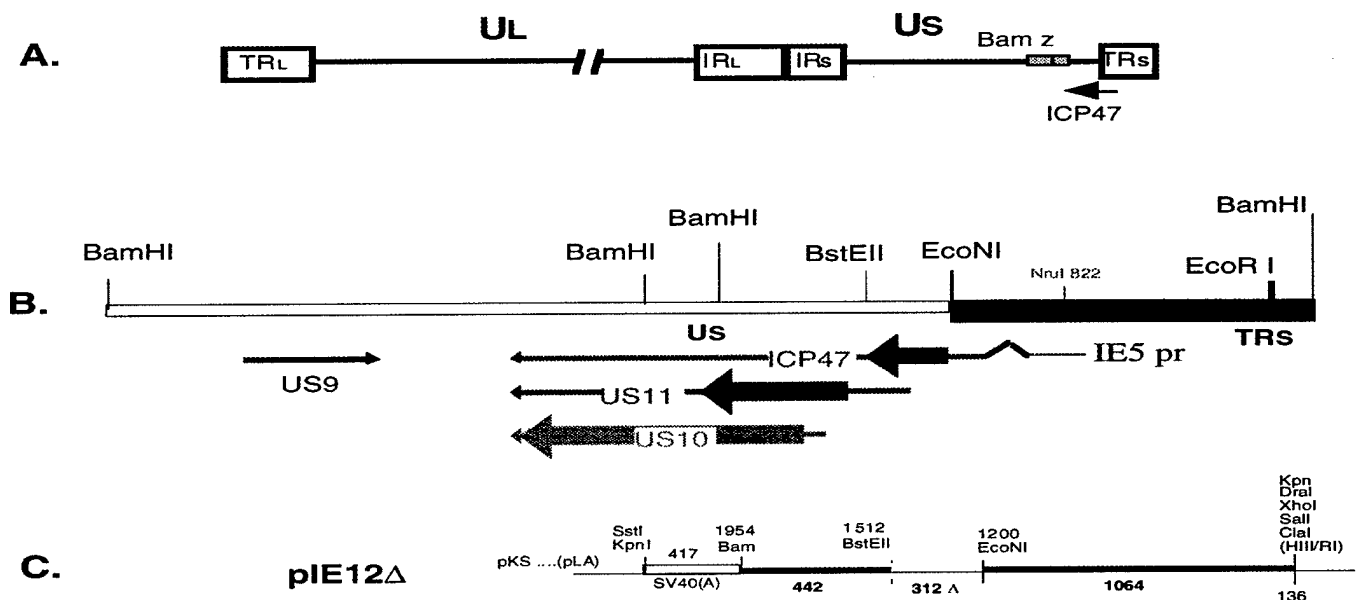

NV1023, NV1034 and NV1042 are later generation vectors and are derived from NV1020. NV1020 is an HSV1-HSV2 hybrid and retains one intact copy of the ICP34.5 gene. NV1023, derived from NV1020 contains deletion of the ICP47 gene similar to G47 Δ . NV1034 and NV1042 are both derived from NV1023 and carry the transgenes, GM-CSF and IL-12, respectively. In addition to the direct oncolytic effect of these viruses on prostate tumors, expression of GM-CSF and IL-12 elicit and enhance a cytotoxic lymphocytic response against the tumors. This feature is particularly significant in treating prostate cancers that have metastasized into other organs within the body. The following demonstrates the construction of NV1020, NV1023, NV1034, and NV1042.

FIGURE 2: Structure of NV Series Vectors

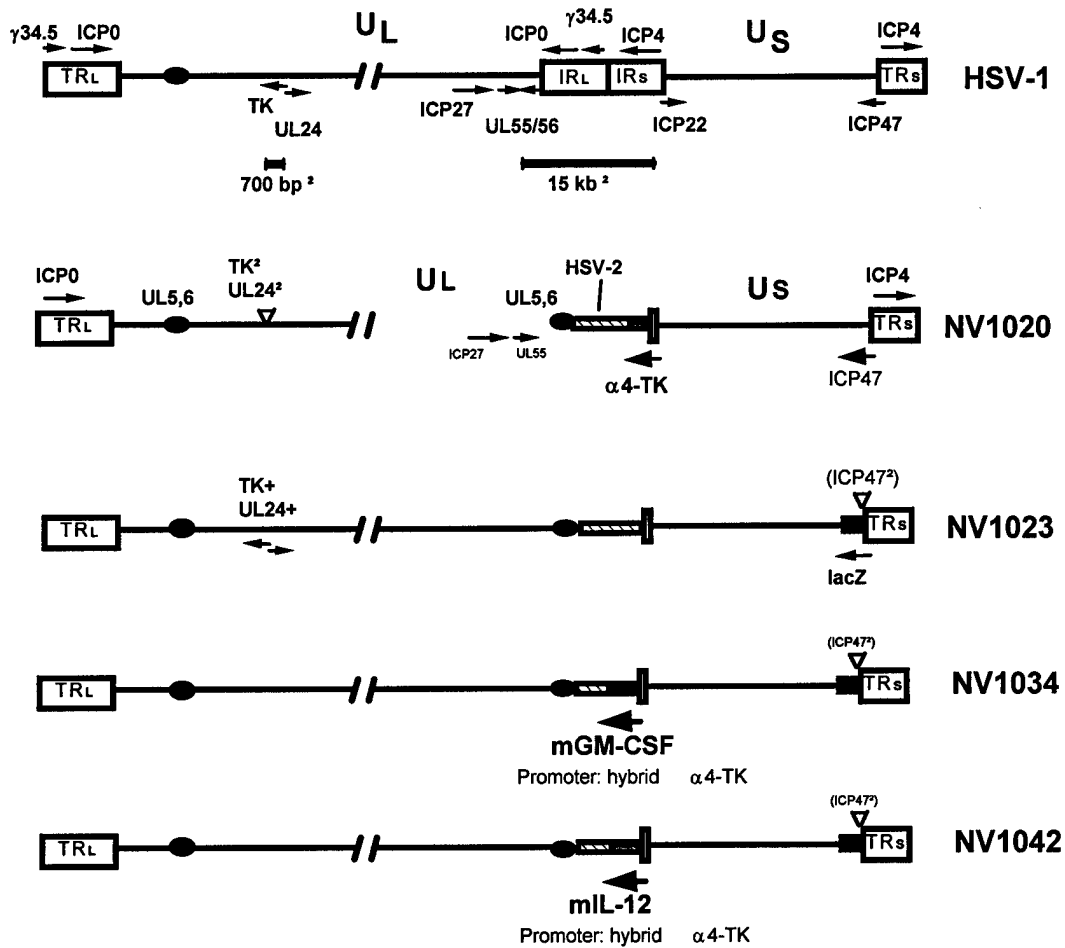

Initial *in vivo* studies have been done using a single prostate cancer implanted in the flank in the appropriate mice for the transgenic mice/ prostate cancer cell line pair being studied. Our first study was aimed at determining how the G-series of vectors (G207; G47 Δ) compares with the NV-series of vectors (NV1023, NV1034, NV1042). Therefore, a direct comparison of the tumoricidal efficacy of G207, G47 Δ and NV1023 was conducted using the TRAMP prostate tumor model. Subcutaneous tumors generated by injecting 1×10^7 TRAMP cells into the left flank of C57BL/6 mice were allowed to grow until a diameter of 5-6 mm. At that time they were treated intratumorally twice, on days 0 and 3, with 1×10^7 pfu of either G207 or G47 Δ or NV1023. We demonstrated that treatment with NV1023 resulted in both an inhibition of tumor growth and a concomitant increase in median survival at doses where both G207 and G47 Δ were ineffective (data not shown).

We also tested the oncolytic efficacy of the cytokine expressing vectors, NV1034 (GM-CSF) and NV1042 (IL-12) and the results for Pr14-2 tumors in C3(1) mice are shown in **Figure 3**. NV1023 was used as control because it is the backbone for NV1034 and NV1042. Subcutaneous flank Pr14-

2 tumors were established in C3(1) mice by transplanting 2 mm³ tumor fragments. When the tumors grew to a diameter of 5-6 mm, they were treated with four intratumoral injections administered on days 0, 3, 7 and 10 of 1 x 10⁷ pfu of either NV1023 or NV1034 or NV1042. Mock mice received virus buffer. The results demonstrate that NV1042 was most effective in inhibiting tumor growth with a reduction to approximately one-third the volume of mock tumor by day 31.

FIGURE 3: Pr14-2 vs. NV Series Intratumoral

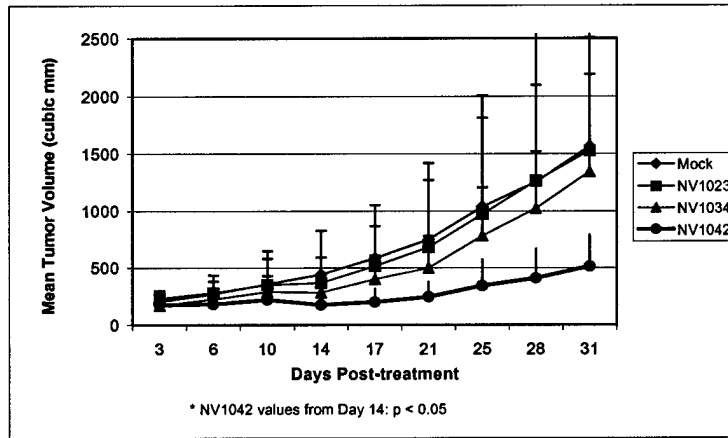

In order to assess the possible stimulation of anti-tumor immunity by NV1042, experiments were conducted using a bilateral TRAMP tumor model. TRAMP tumors were established on both flanks of C57BL/6 mice and NV1023 or NV1034 or NV1042 was intraneoplastically administered to one tumor (treated tumor). The results (Figure 4) demonstrate that the IL-12 containing vector, NV1042, causes a markedly significant tumor growth inhibition (p<0.05 vs. other treatments) of the treated tumor and lesser but significant inhibition (p<0.05 vs. mock) of the untreated tumor as well. This small result on the contralateral tumor (in comparison to other tumor models studied) is not totally unexpected, as TRAMP tumor cells have been reported to have very low levels of MHC class I expression in vivo.

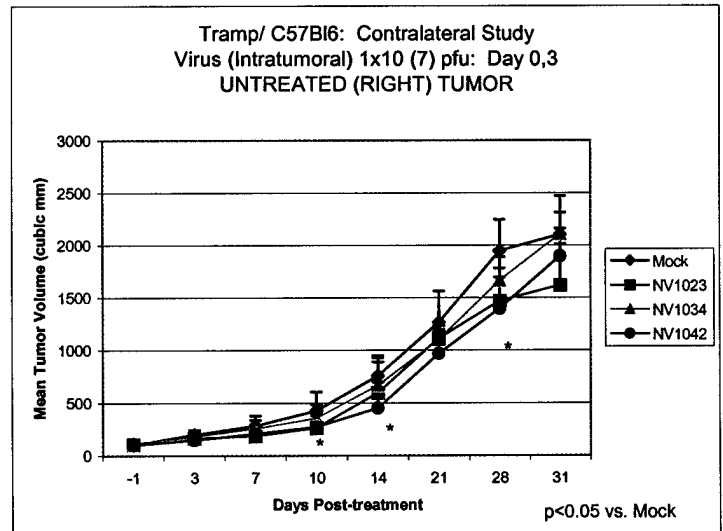
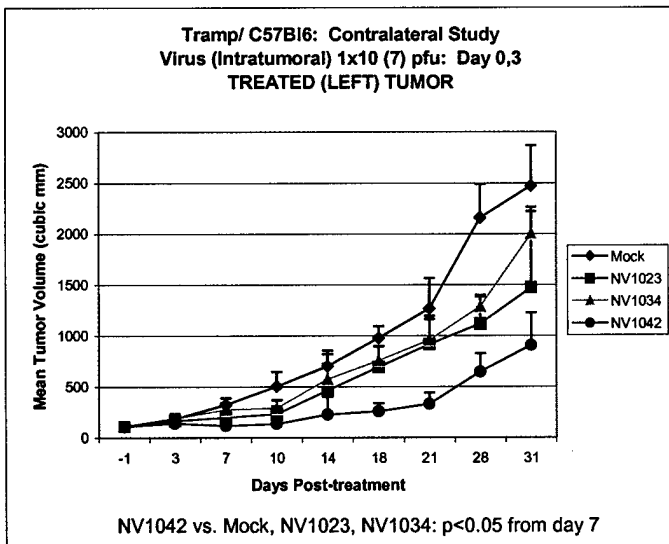

FIGURE 4: Tramp Bilateral Tumors/ Unilateral Intratumoral Treatment

Similar results were obtained with our second prostate cancer model, Pr14-2 tumors grown in FVB/N C3(1) TA_g mice. As shown below (Fig. 5), NV1042 treatment resulted in significant reduction of tumor volume on the treated tumor ($p < 0.05$ from day 21); however, in this particular study, it did not reach statistical significance on the contralateral side. We suspect that the lack of significance on the contralateral side in Pr14-2 tumor model in comparison to TRAMP, might be due to the following reasons: (1) The Pr14-2 tumors are generated from tumor transplants as compared to TRAMP in which tumor cells are used to generate tumors. Hence, the Pr14-2 tumors are pre-formed tumor fragments and the growth is much more variable with higher standard deviations than similar studies done with implanted cell suspensions, (2) In the Pr14-2 tumor model the number of animals that were available for studies were only 5 as compared to TRAMP where we had an "n" value of 10 animals. Both of the above factors could have contributed to the high degree of standard deviation observed with Pr14-2 thus affecting the significance value. This will need to be repeated with a higher "n".

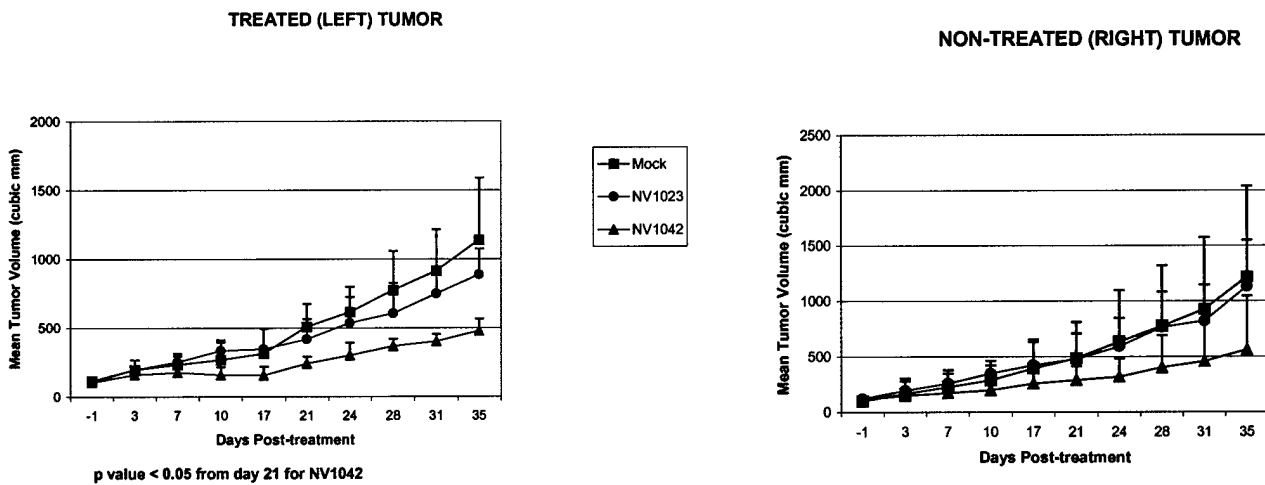

FIGURE 5: Pr14-2 Bilateral Tumors/ Unilateral intratumoral Treatment

We next wished to explore the use of HSV vectors delivered intravenously in these transgenic tumor models. In prior studies we demonstrated that intravenous administration of G207 inhibited human prostate cancers established in athymic mice, with tumor elimination observed in one-fourth of the tumors. Preliminary studies in our laboratory indicate that intravenous administration of 1×10^7 pfu of G207 is safe in Balb/c mice.

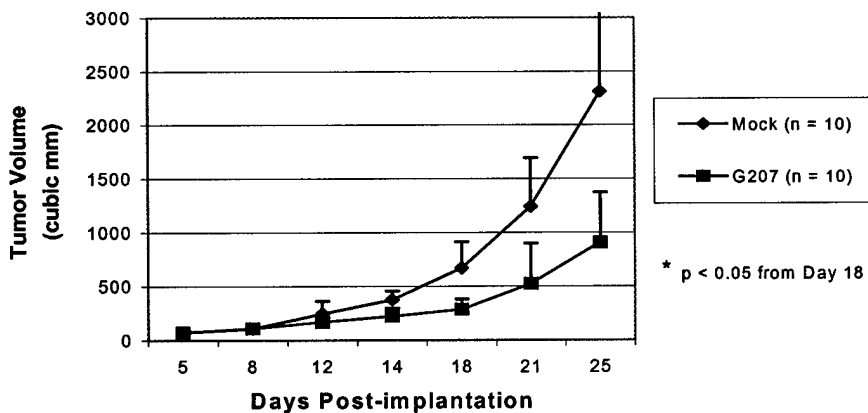
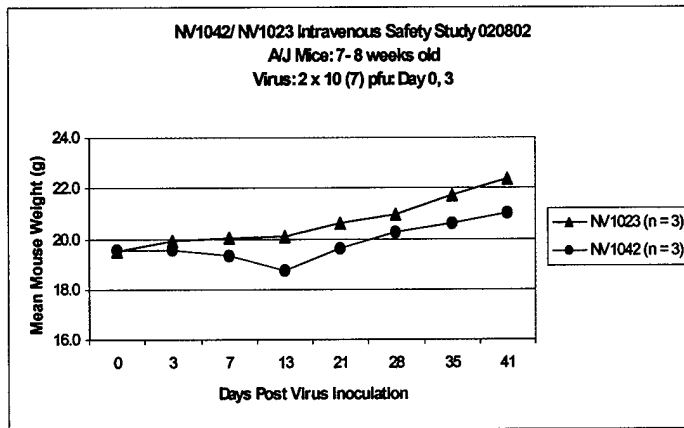

FIGURE 6: Intravenous G207 Treatment of Tramp Tumors

Based on these observations, we conducted experiments to determine the efficacy of several HSV vectors for systemic therapy of prostate tumors. Subcutaneous TRAMP tumors established by injecting 5×10^6 cells into the flanks of C57BL/6 mice were treated with 2×10^7 pfu of G207 administered via tail vein on day 0, 2, 4 and 6. Results are shown in Fig 6 above. The growth rate of treated tumors was reduced by approximately 50% as compared to mock treated tumors by day 25. Since our prior studies comparing G-series vectors with NV-series vectors demonstrated greater efficacy with NV1042 when administered intratumorally, we were interested in evaluating the efficacy of NV series vectors for systemic therapy, i.e., by intravenous administration. However, before we test the efficacy, we had to test their safety. Therefore, we conducted a pilot experiment to assess the toxicity of NV1023 and NV1042 delivered intravenously in A/J mice. The results are shown in Fig. 7. Only minor variations in body weight were observed in the NV1042 treated group as compared to NV1023, but no morbidity or mortality was observed.

FIGURE 7: Intravenous Safety of NV1042



After determining from the above pilot study that NV vectors can be delivered intravenously, we undertook the efficacy study. A positive systemic effect was observed using NV1023 and NV1042 virus administered intravenously in treating TRAMP tumors as shown below (Figure 8). Of note, with the NV series of vectors, efficacy was seen with only two intravenous inoculations rather than four used with G207.

FIGURE 8: Tramp Intravenous With NV-Vectors

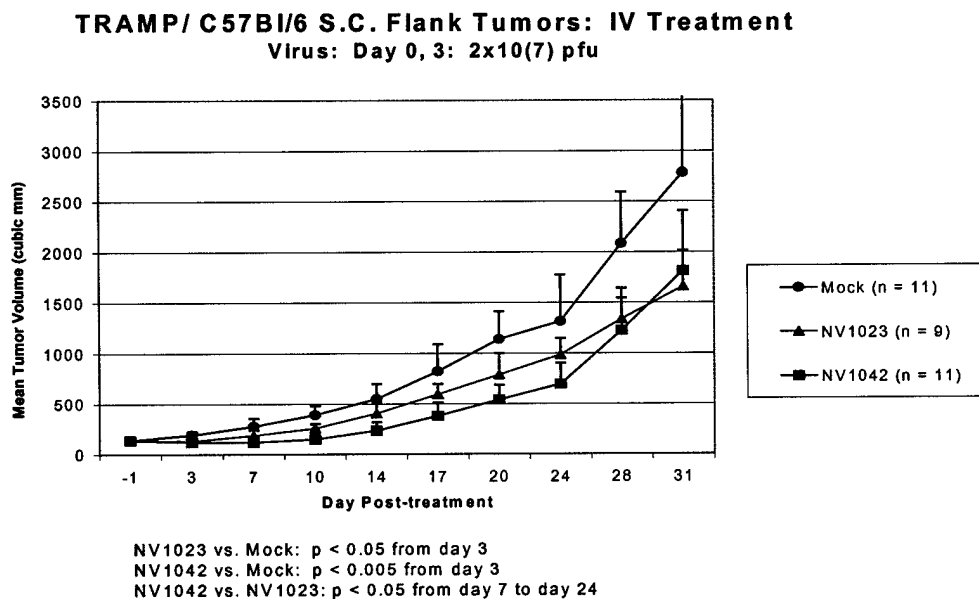

PLANS FOR THE UPCOMING YEAR:

Having accomplished not only our 12 month goals but even some of the goals initially planned out to 18 months, we are now in a position to go forth with our extended plans.

In this next year we will perform:

HYPOTHESIS 1:

- *In vitro* HuVEC studies will be finished by the end of 18 months.
- *In vivo* studies of effects on vasculature and associated histology studies will be finished by 22 months.

HYPOTHESIS 2:

- Studies in seropositive animals will be completed by the end of 18 months.
- Studies assessing the possible effects of dexamethasone or cyclophosphamide will be completed by 21 months.
- Studies involving cisplatin and HSV will be completed by 24 months.

HYPOTHESIS 3:

- *In vivo* testing of systemic administration of various immunomodulatory factors in combination with the dvB7lg/G207 therapy will be completed by the end 21 months.
- *In vivo* testing of combining *gpt* suicide gene therapy with the dvB7lg/G207 therapy will be completed by the end of 21 months.
- Generation of dvB7lg using, as a helper virus, HSV with higher oncolytic activity than G207, and its *in vivo* testing will be completed by 24 months.

KEY RESEARCH ACCOMPLISHMENTS:

- The NV-series of vectors are more efficacious in the mouse prostate models than the G-series.
- In a bilateral tumor model, the IL-12 containing vector, NV1042, causes a markedly significant tumor growth inhibition of the treated tumor and lesser but significant inhibition of the untreated tumor as well.
- NV 1023 and NV1042 can be administered safely by intravenous route in mice
- G207, NV1023, and NV1042 show efficacy after intravenous administration in a mouse Tramp model system

REPORTABLE OUTCOMES:

We are now using this data to prepare:

- An R01 grant to the NIH
- A grant to a private funding agency
- A manuscript on the results

CONCLUSIONS: This work for the first time demonstrates that two different transgenic systems can be used to study efficacy of herpes oncolytic vectors. This will allow us to then study these vectors in the tumors occurring *in situ* in these transgenic animals and also will allow us to study improvements in these vector systems which we expect to ultimately translate into clinical trials.

REFERENCES: none necessary

APPENDICIES: none