

3058RF9A

MEMORANDUM FOR PRS (In-House Publication)

FROM: PROI (STINFO)

18 June 2002

SUBJECT: Authorization for Release of Technical Information, Control Number: **AFRL-PR-ED-VG-2002-151**
Doug Talley (PRSA), "Recent Developments in Liquid Rocket Injectors" (viewgraphs only)

AIAA Short Course: Liq. Prop. Systems - Evol & Advancements
(Indianapolis, IN, 11-12 July 2002) (Deadline = 11 July 2002)

(Statement A)

1. This request has been reviewed by the Foreign Disclosure Office for: a.) appropriateness of distribution statement, b.) military/national critical technology, c.) export controls or distribution restrictions, d.) appropriateness for release to a foreign nation, and e.) technical sensitivity and/or economic sensitivity.

Comments: _____

Signature _____ Date _____

2. This request has been reviewed by the Public Affairs Office for: a.) appropriateness for public release and/or b) possible higher headquarters review.

Comments: _____

Signature _____ Date _____

3. This request has been reviewed by the STINFO for: a.) changes if approved as amended, b) appropriateness of references, if applicable; and c.) format and completion of meeting clearance form if required

Comments: _____

Signature _____ Date _____

4. This request has been reviewed by PR for: a.) technical accuracy, b.) appropriateness for audience, c.) appropriateness of distribution statement, d.) technical sensitivity and economic sensitivity, e.) military/national critical technology, and f.) data rights and patentability

Comments: _____

APPROVED/APPROVED AS AMENDED/DISAPPROVED

PHILIP A. KESSEL Date
Technical Advisor
Space and Missile Propulsion Division

Recent Developments in Liquid Rocket Injectors

Doug Talley
Liquid Rocket Combustion Group Leader
Space and Missile Propulsion Division
Air Force Research Laboratory

Liquid Propulsion Systems – Evolution and Advancements, 11-12 July 2002, Indianapolis, IN

Outline

- Introduction to rocket injectors
- Major trends since the end of the cold war
- Recent developments in rocket injector design tools
- Case study: gas/gas injector development
- Injection at supercritical pressures
- Closing comments

Introduction to rocket injectors

Major kinds of rocket injectors

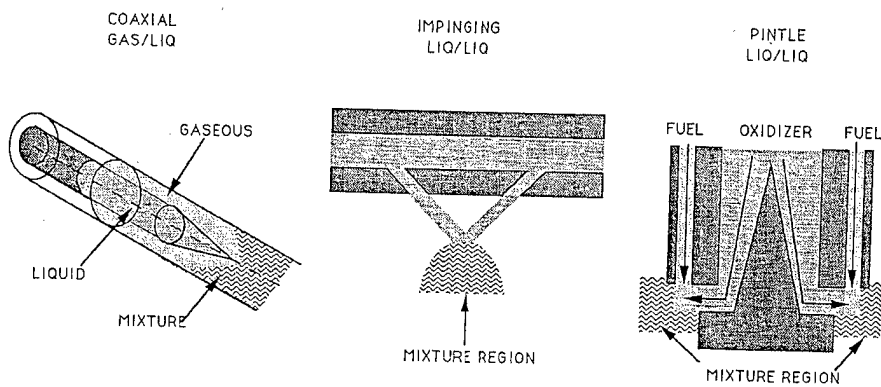



Major kinds of rocket injectors

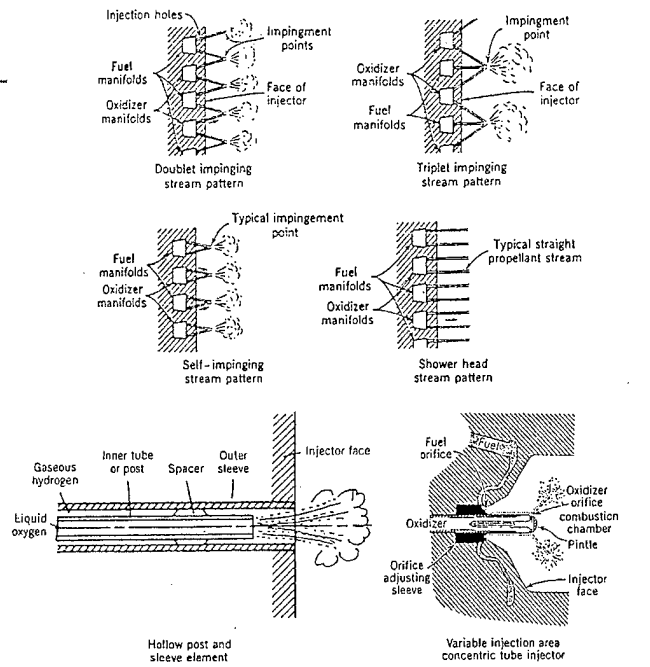

From Sutton, "Rocket Propulsion Elements," 6th ed., pg 299, Wylie 1992



Space Shuttle Main Engine Injector

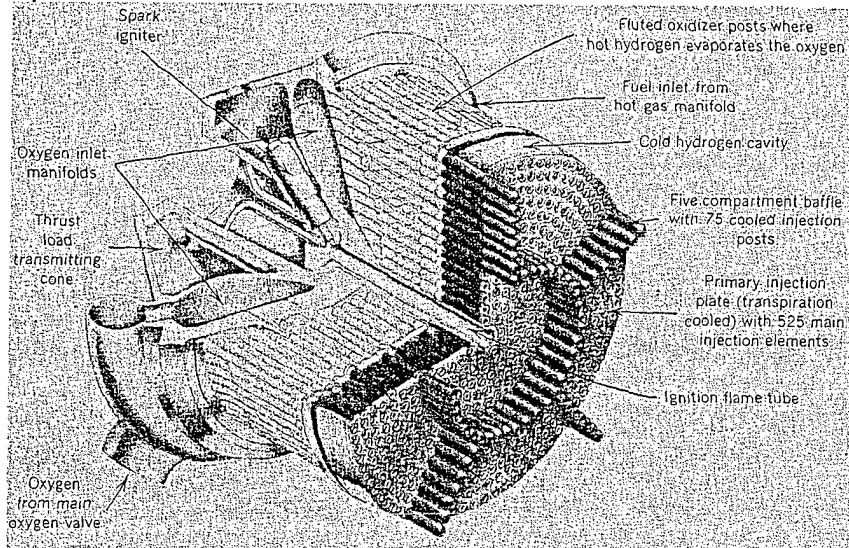

From Sutton, "Rocket Propulsion Elements," 6th ed., pg 277, Wylie 1992

SSME POWERHEAD COMPONENT ARRANGEMENT

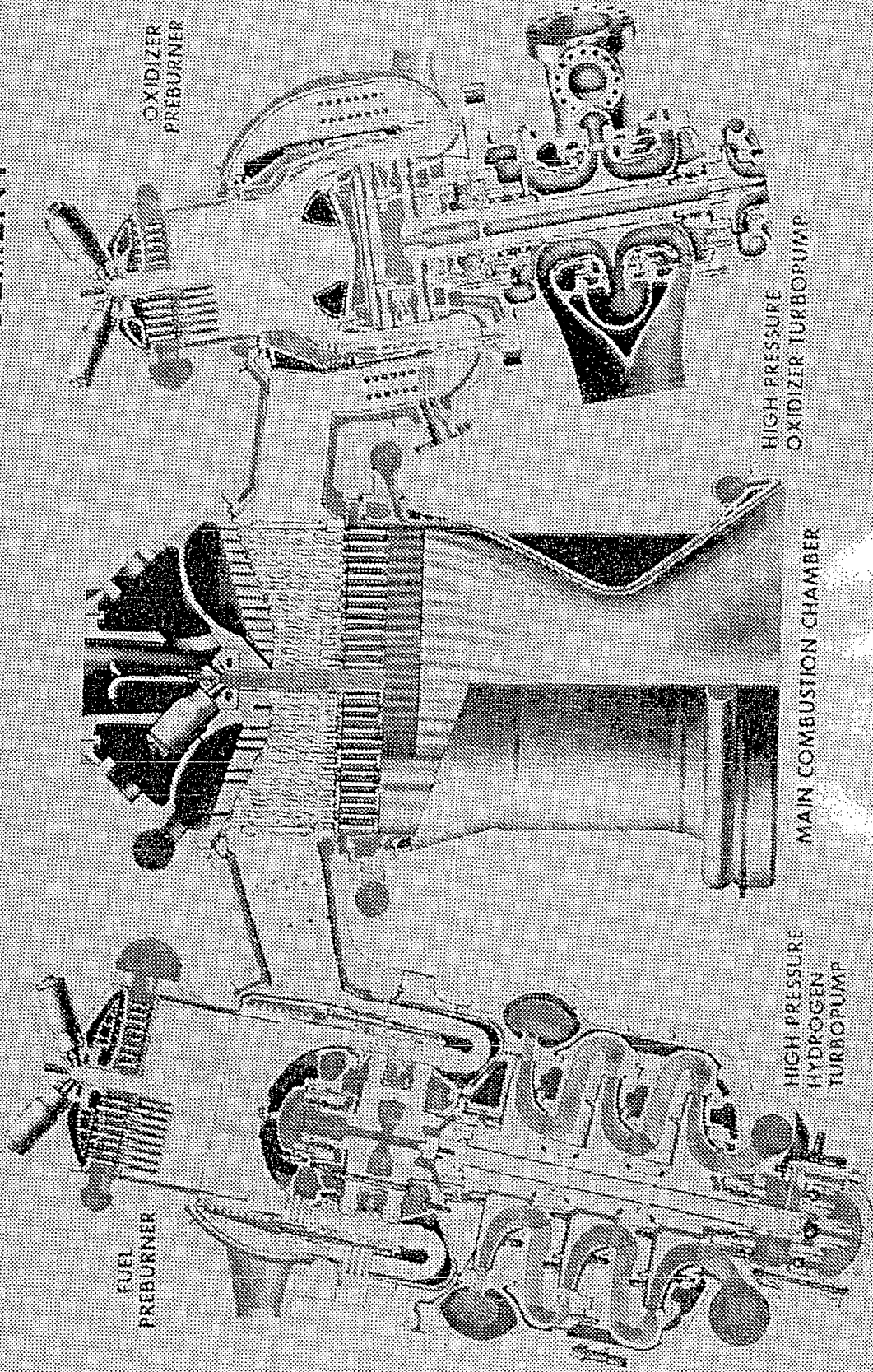

SSME fuel preburner element

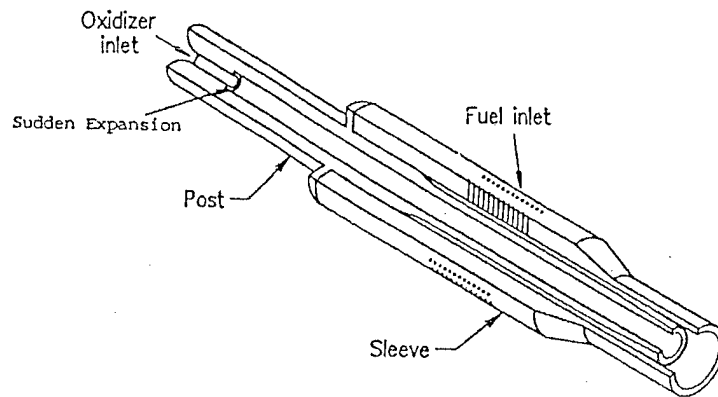

AIAA 90-2186

Impinging element injector

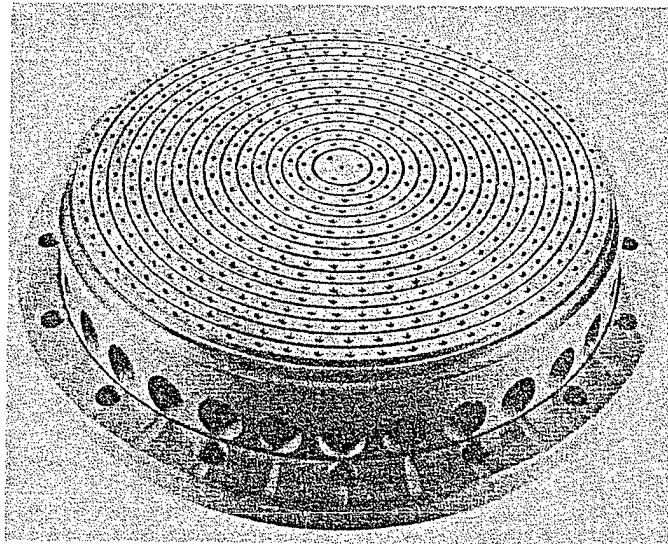
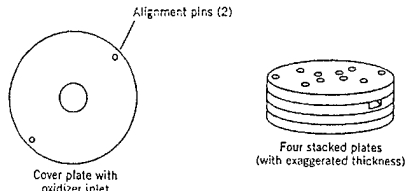
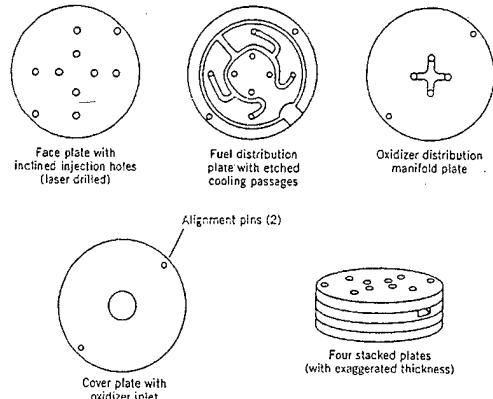
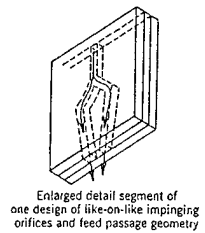
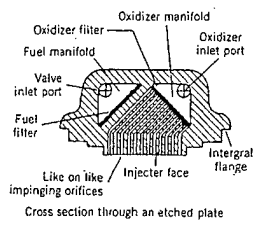

Photo from Sutton, "Rocket Propulsion Elements," 6th ed., pg 300, Wiley 1992

Platelette bonded injectors



(a)



From Sutton, "Rocket Propulsion Elements," 6th ed., pg 301, Wylie 1992

Separate slides

- SSME cutaway
- SSME injector
- SSME single element injector
- Platelette injector concept
- Henken platelette
- Spashplate platelette

Overall characteristics

- Pressures (main chamber):
500 – 4000 psi
- Flow rates:
 - very small (satellite thrusters) to rates that can drain average swimming pools in seconds (boosters).
- Combustion chamber volumes:
 - $O(1 \text{ in}^3)$ (satellite thrusters) to $O(1 \text{ ft}^3)$ (boosters)
- Propellants:
 - GOX, LOX, H_2 , RP-1 (kerosine), NTO/MMH, many more.

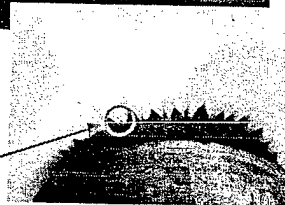
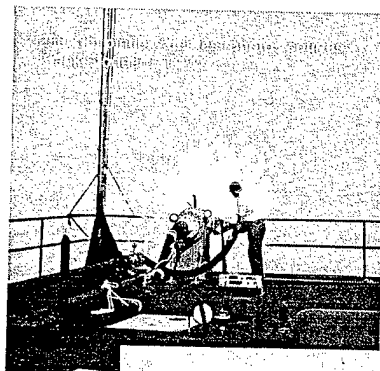

Single element
 $\epsilon - 10 \text{ lb/s/element}$

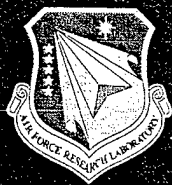

AFRL test stand 1A flare stack test

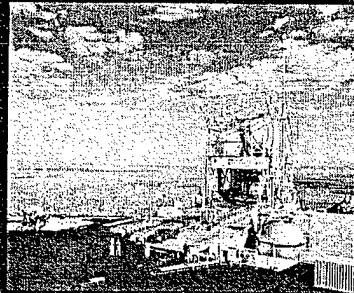
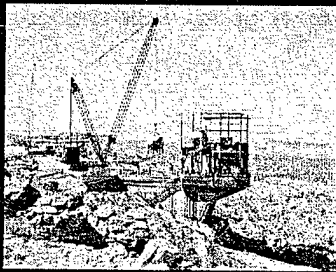

Air Force Research Laboratory Propulsion Directorate Edwards Research Site

Test Stand 1A is a liquid rocket engine test stand designed for static firing the largest rocket engines ever built, with thrusts up to 1,600,000 pounds. Originally built in 1956 for the Atlas Intercontinental Ballistic Missile Program, the stand was modified into a rocket engine stand in 1960 for the Apollo program. The first stage engine of the Saturn V moon rocket, the F-1, was test fired on 1A for most of the Apollo years. In 1995, a decision was made to modify Test Stand 1A for the Evolved Expendable Launch Vehicle (EELV) program. Liquid hydrogen systems were added to the stand to provide the capability of testing cryogenically-fueled engines. The instrumentation and control systems for the stand have been completely upgraded to the latest state-of-the-art.

The 1A test stand is an integral part of the I-120 Large Rocket Engine Development and Test Facility, where rocket engine technologies for the future are being developed for the U.S. Air Force. Testing capabilities have been improved, allowing both commercial and Government-funded programs to coexist within the test facility, maximizing use of the facility resources.

Test Stand 1A Specifications:

90,000 gal Liquid Hydrogen Run Tank	1.6Mibf Thrust Measurement System
75,000 gal Liquid Oxygen Run Tank	60,000 HP Facility Turbine Drive System
300 lb/sec Hydrogen Flare Capability	Separate Kerosene Run Tank
320 channel, 100K sample/sec Digital Data Acquisition System	
Flame deflector with 1,000,00 gallons cooling water	

About the Photo:

Main Photo: Test Stand 1A during a liquid hydrogen flow test. The large flame, which peaked at almost 700 ft above grade, was the result of flowing 200 lb/sec liquid hydrogen for 5 seconds into the main flarestack. The 1A superstructure is 100 feet high. The structure to the right in the foreground is Test Stand 2A, the facilities' component development stand.

Left Inset: Test Stand 1A during the installation of the 90,000 gallon liquid hydrogen run tank. The 900 ton Manitowoc crane is one of the largest mobile cranes in the world. The facility is positioned over the side of a mountain, allowing the rocket exhaust to travel 150 ft downward before impacting the water-cooled flame deflector.

Right Inset: This 1997 ribbon-cutting ceremony shows the completed test stand and gives a size perspective of the facility.

Injector requirements

- Complete combustion in the shortest possible length
 - Main injectors: performance vs weight tradeoffs
 - Preburners/GG's: downstream component interactions, eg, turbine blades, etc
- Acoustically stable
 - Chamber modes
 - Feed system coupling
- Chamber/wall compatibility
 - Heat transfer/cooling
 - Oxygen blanching
 - Lifetime
- Minimize pressure drop
- Throttling
- Ignitable; minimum ignition transients
- Cost, weight
- The "ilities:"
 - Reliability
 - Maintainability
 - Manufacturability
 - Durability
 - Operability
 - *PREDICTABILITY*

Major trends since the end of the cold war

Major trends since the end of the cold war

- Infusion of Russian (formerly Soviet) technology
- Continued rise of cost as a major consideration.
Injector impacts:
 - Aversion to risk
 - Interest in using CFD tools combined with subscale data
- Gas/gas injectors
- Understanding of injection phenomena at supercritical pressures.

Russian experience: injector impacts

Relative Soviet disadvantage in machining

- Fewer, coarser elements, larger thrust-per-element
 - O(10,000 lbf/element) vs O(1,000) lbf/element in the US.
- Tendency towards coaxial elements, typically swirl coaxial
 - Counter-swirl variants
- Injectors were highly performing despite coarseness

Russian experience: injector impacts

Use of coatings

- Injector impact: mitigates against streaking caused by coarse elements

Use of oxidizer-rich preburners

- Partially enabled by use of coatings
- Contrary to conventional US wisdom at the time
- Contributed to US interest in full flow staged combustion cycles

Full flow staged combustion cycle

Advantages

- Eliminate F/O seal in LO2 pump
 - Reduce weight
 - Eliminate catastrophic failure mode
- Reduce Ox turbine input temp
 - Reduced maintenance and failures
- No cryogenics downstream of preburner; "standard" piping

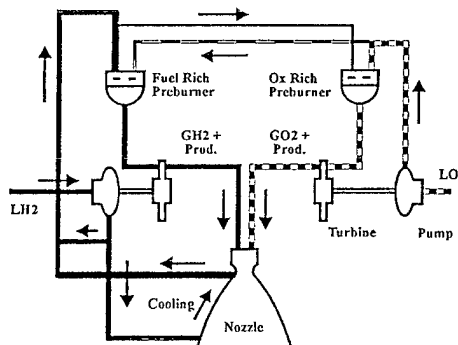

Injector impact

- Gas/gas main injectors
 - No previous experience at main injector scales

Injector-related developments of the 1990's +

Vehicle	Veh. yr.	Engine	Stage	Manuf.	Eng. yr.	Propellants	Inj. type	Notes
Allas V	2002	RD-0180	main	NPO Energomash	1999	Lox/kerosine	sw. coax	Two chamb. var. RD170 (1970's)
Allas V	2002	RL-10A-2	upper	Pratt	1995	Lox/H ₂	coax	Derivative of 1980's engine
Arienne 5	1996	Vulcain	main	SEP	1996	Lox/H ₂	coax	Europe
Arienne 5	1996	Aestus	upper	DaimlerChrysler	1996	N ₂ O ₄ /MMH	coax	Europe
Arienne 5E	dev	VINCI	upper		dev	Lox/H ₂		Europe
Baal BA-2	dev	Baal	main	Baal	dev	H ₂ O ₂ /kerosine	unk.	Privately funded
DC-X		RL-10A-5	main	Pratt		Lox/H ₂	coax	
Delta IV		RS-68	main	Rocketdyne		Lox/H ₂	coax	EELV
Delta IV		RL-10-B-2	upper	Pratt		Lox/H ₂	coax	EELV
H2		LE-7	main	Pratt		Lox/H ₂		Japan
H2		LE-5E	upper			Lox/H ₂		Japan
Kistler K-1		NK33, Nk43	main			Lox/kerosine	sw. coax	Russian engine on US vehicle
Long March		YF-40	main			N ₂ O ₄ /MMH		China
Rotary Rocket		RR	main	RR		H ₂ O ₄ /kerosine	unk.	Privately funded
Scorpion		Scorpion	main	Microcosm		Lox/kerosine	impinger	Privately funded
Shuttle		SSME block II	main	Rocketdyne		Lox/H ₂	coax	upgrade
Titan IV		LE-67-11, LE-91-11	main	Aerojet		N ₂ O ₄ /Aerozinc - 50	impinger	
X-33			main	Rocketdyne	dev.	Lox/H ₂		
X-34		Fastrac	main	NASA		Lox/kerosine	impinger	
SLI	dev	dev	dev		dev	dev		NASA Space Launch Initiative
-	-	RL-50/60	upper	Pratt		Lox/H ₂	coax	
-	-	Integrated Powerhead Demo	boost	Rocketdyne/Aerojet		Lox/H ₂	proprietary	IHPRPT*
-	-	TRW 600 Kibf pintle	boost	TRW		Lox/H ₂	pintle	

Rocket Propulsion Technology program

Injector-related developments of the 1990's +

General Trends

- Risk-adverse tendency to stick with proven injector types, with some exceptions:
 - Integrated Powerhead Demo preburner and main injectors
 - ❖ Gas/gas main injector development (discussed later)
 - Hydrogen peroxide injectors
 - ❖ Nearly all proprietary – not discussed here
 - Notable mention given to pintle injector development
 - ❖ Although the basic type was not changed, there was a respectably large extrapolation beyond existing experience (to a 600 Kibf H₂O₂ test).



Recent developments in liquid rocket injector design tools

Outline

- Overview of atomization
- Recent developments in modeling
- Recent developments in experimental methods
 - Cold flow characterization of rocket injectors at AFRL



Overview of atomization

Atomization steps

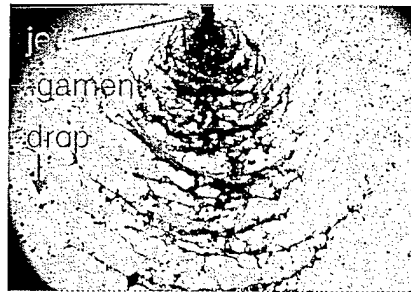

Impinging element spray; plane of jets perpendicular to slide

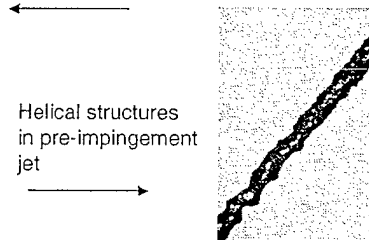

- Primary atomization

Breakup of jets and sheets into long irregularly shaped ligaments

- Secondary breakup

Breakup of ligaments into droplets
Breakup of drops into smaller drops

- Vaporization/combustion

Gasification so that fuel and oxidant can mix at the molecular level and burn

Breakup mechanisms

- Shearing
- Liquid phase turbulence
- Surface tension

An efficient atomization mechanism:

Stretch-Thin-Shear

(stretch liquid into the thinnest possible sheets, then shear)

Stretch-Thin-Shear illustrated for a typical prefilming atomizer (non-rocket)

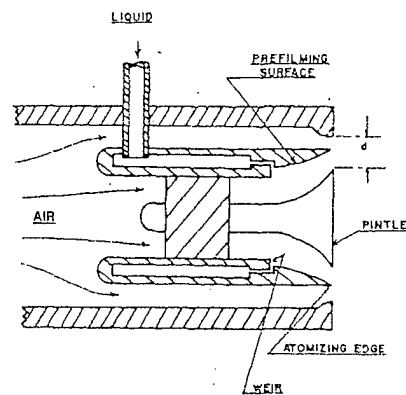

Rizk, N.K., and Lefebvre, A.H., "The Influence of Liquid Film Thickness on Airblast Atomization," Journal of Engineering for Power, vol. 102, pp. 706-710, July 1980.

Overview: drop size distributions

- Nukiyama and Tanasawa (four parameter)

$$\frac{dN}{dD} = aD^p \exp[-(bD)^q]$$

where a, b, p, q are parameters

- Rosin-Rammler (two parameter)

$$1 - Q = \exp[-(D/X)^q]$$

where Q is the fraction of the total volume contained in drops of diameter less than D , X is the diameter such that 63.2% of the total liquid volume is in drops of smaller diameter, and q is a parameter.

- Several others

experimental distribution
(form unspecified)

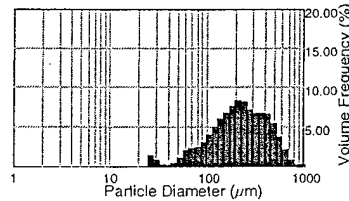

Overview: representative drop diameters

Mean diameters

$$D_{ab} = \left[\frac{\sum N_i D_i^a}{\sum N_i D_i^b} \right]^{1/(a-b)}$$

a	b	$a + b$ (order)	Symbol	Name of mean diameter	Expression	Application
1	0	1	D_{10}	Length	$\frac{\sum N_i D_i}{\sum N_i}$	Comparisons
2	0	2	D_{20}	Surface area	$\left(\frac{\sum N_i D_i^2}{\sum N_i} \right)^{1/2}$	Surface area controlling
3	0	3	D_{30}	Volume	$\left(\frac{\sum N_i D_i^3}{\sum N_i} \right)^{1/3}$	Volume controlling, e.g., hydrology
2	1	3	D_{21}	Surface area-length	$\frac{\sum N_i D_i^2}{\sum N_i D_i}$	Absorption
3	1	4	D_{31}	Volume-length	$\left(\frac{\sum N_i D_i^3}{\sum N_i D_i} \right)^{1/2}$	Evaporation, molecular diffusion
3	2	5	D_{32}	Sauter (SMD)	$\frac{\sum N_i D_i^3}{\sum N_i D_i^2}$	Mass transfer, reaction
4	3	7	D_{43}	De Brouckere or Herdan	$\frac{\sum N_i D_i^4}{\sum N_i D_i^3}$	Combustion equilibrium

Overview: representative drop diameters

Median diameters: $D_{0.xx}$

where $xx\%$ of the total liquid volume is in drops of smaller diameter

- $D_{0.5}$ is known as the Mass Mean Diameter, MMD
- NOTE: when the shape of the distribution is known, it is only necessary to report one diameter, plus ratios of diameters equal to the total number of free parameters in the distribution.

Rocket mean diameters from the 1960's

- Tend to be reported as D_{43}

$$D_{43} = \frac{\sum N_i D_i^4}{\sum N_i D_i^3}$$

which is a volume-weighted mean diameter

- Reason: old data used the molten wax technique
 - Sieving process gives a volume weighted mean.

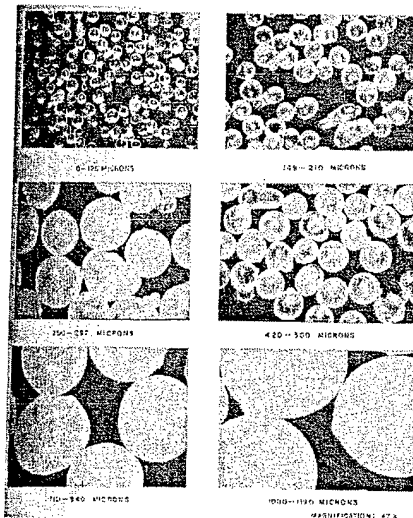

Wax sieve cuts

Sample advancement: secondary breakup

Secondary breakup regimes

$$We = \rho_g d_0 u_0^2 / \sigma$$

$$Oh = \mu_l / (\rho_l d_0 \sigma)^{1/2}$$

Chou, Hsiang and Faeth,
Int. J. Multiphase Flow, Vol.
 23, 1997

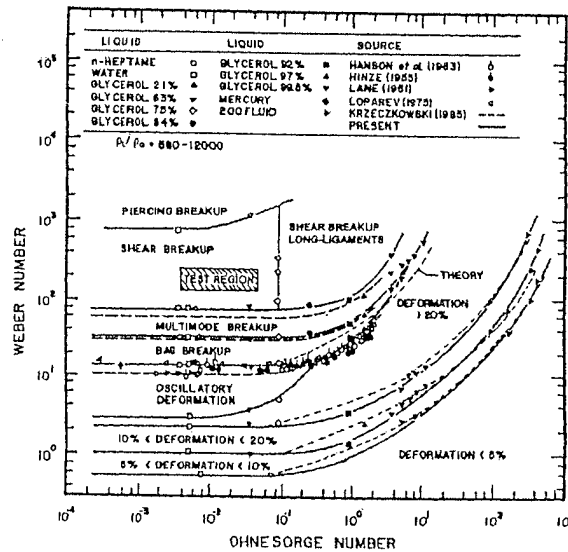

Advancements in secondary breakup

- Regimes mapping when different kinds of breakup occur, but that was all
- Chou and Faeth correlated data for the bag breakup regime which gives a complete picture:
 - How long it takes to breakup
 - Size of the parent droplet when breakup stops
 - Size distribution of all the daughter droplets
- NOTE: The results of this sample advancement pertain to liquid-to-gas density ratios of about 500, much larger than in most rockets
 - Many recent advancements in atomization don't pertain to rocket conditions

Chou and Faeth, *Int. J. Multiphase Flow*, Vol. 24, 1998



Recent developments in modeling



Computer resources

- Increases in processor speed
 - Currently O(2.2GHz)
 - <100MHz 10 years ago.
- Massively Parallel Computing
 - Multiple processor computers
 - Clusters
 - Reduced cost
- Increased computer power provides ability to compute flows with more physics, and with greater resolution and speed.

Advances in communication between codes

- Typically the design of components such as thrust chambers involves the use of more than one code to perform the required calculations
 - Feed system codes
 - Injector codes
 - Combustion chamber cooling codes
 - Film cooling codes
 - Nozzle codes
 - Instability codes
- Use of different codes requires transferring information between them, which can be extremely tedious
- Executive codes are being developed which automate the hand-offs between codes, saving significant time
 - Boeing Thrust Chamber Analysis Toolkit (TCAT)

Advances in gas-side CFD

- More robust numerical algorithms
 - Preconditioning
 - Choi, Y.H. & Merkle, C.L., "The Application of Preconditioning in Viscous Flows," *J. Comp. Phy.*, 72, 1987.
 - Discretization schemes
 - ◆ Multigrid
 - Mavriplis, D.J., "Multigrid Techniques for Unstructured Meshes," ICASE Report No. 95-27, April 1995.
 - ◆ Conservation Element/Solution Element (Wang et al.)
 - Wang, X.-Y., Chow, C.-Y., & Chang, S.-C., "Application of the Space-Time Conservation Element and Solution Element Method to Two-Dimensional Advection-Diffusion Problems," NASA-TM-106946, 1995.
 - ◆ Advection Upstream Splitting Method (AUSM)
 - Liou, M.-S., & Steffen, C.J., "A New Flux Splitting Scheme," *J. Comp. Phy.*, 107, 1993.

CASE =
unintentional
NASA, 1995

Advances in liquid-side CFD

• Surface Tracking Algorithms

■ Volume of fluid

Bussmann, M., Mostaghimi, J., & Chandra, S., *Phys. Fluids*, **11**, 1999.

■ Free surface tracking

Helenbrook, B.T., *Comp. Meth. Appl. Mech. Eng.*, **191**, 2001.

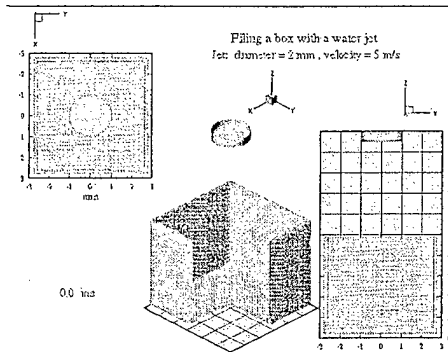

CFD for rocket applications

- Improved computer power allows more physics to be included with greater resolution, but the physical models continue to remain mostly not validated for rocket conditions
 - High pressure and temperature
 - Supercritical fluids
 - Dozens of species and scores of reactions
- Computer resources are still not adequate for simulating complex injector phenomena
 - Atomization is sensitive to upstream manifolding; upstream manifolding must also be modeled
 - Modeling atomization requires resolving turbulent length scales inside tiny orifices
 - Computing rocket design parameters such as wall heat fluxes requires resolution of the entire combustion chamber



CFD for rocket applications

Consequence

- Injector atomization performance currently tends to be an experimental input into, not a computation resulting from, most liquid rocket combustion design codes.



Recent developments in
experimental methods

The problem

- Most of engine development cost has historically been spent on trial-and-error fixes of problems developed after full scale design is complete.
- Problems not discovered until full scale testing tend to be extremely expensive to fix, and have historically required sacrificing original engine performance and/or lifetime goals.

Hierarchy of injector experiments

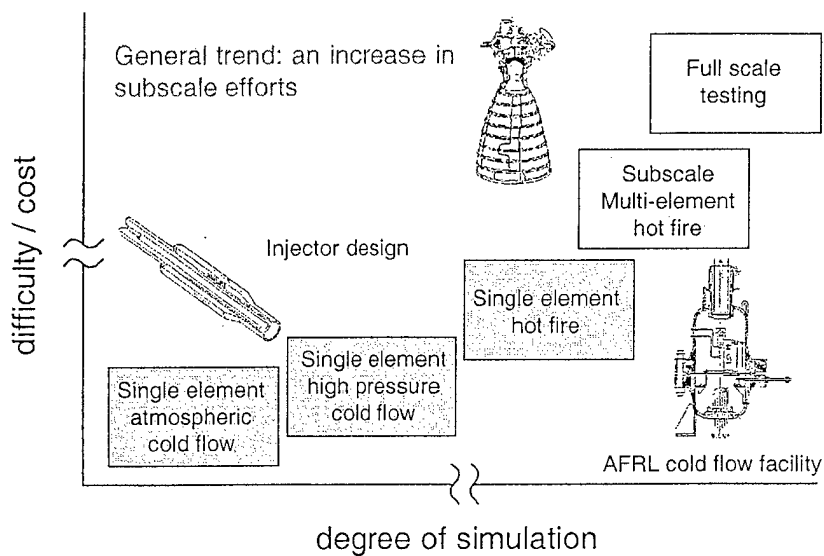

Subscale facilities with advanced measurement capability

All dates are approximate

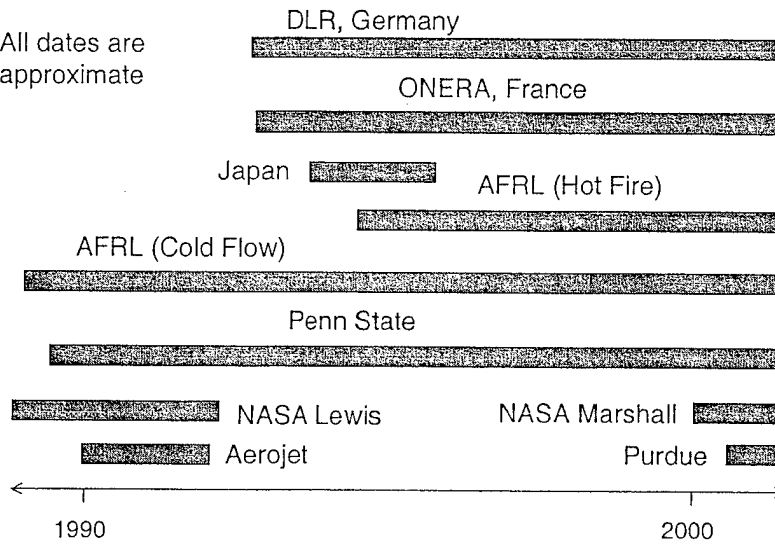

What good are subscale experiments?

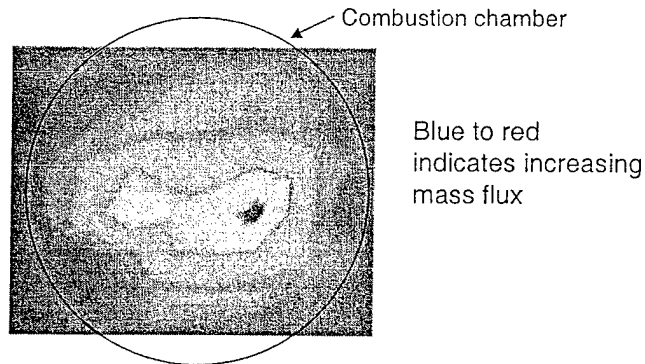

Would you hot fire an injector with this cold flow pattern?

What good are subscale experiments?

- The performance of these two injectors is projected to be essentially equivalent
 - Choose the one that's cheaper or that has some other advantage

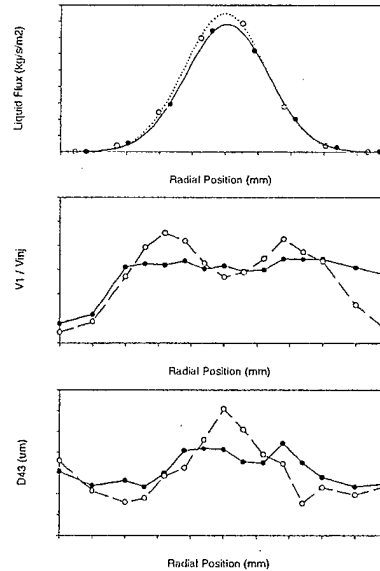

Thoughts on scaling

- *Trend analysis*: the expectation that trends, if not magnitudes, are often preserved between scales.
 - Supported by experience in rockets and elsewhere that injectors which do relatively better in cold flow tend to do relatively better in hot fire – eliminate obvious bad designs.
- *Bracketing and limiting*: case-dependent projections of the directions in which performance at one scale will deviate from performance at another scale.
 - Ex: an injector that has a c^* efficiency of 95% as a single element may often be expected to have a c^* efficiency of 95% or better as multi-element.
 - Ex: if you're burning something up at low pressures, chances are you're going to burn it up at high pressures.



Thoughts on scaling

- *Code validation*: if validated at one scale, codes may often have the necessary correct physics to extrapolate reliably to another scale.
- *Physical understanding*: If mysterious things are happening, any scale which provides understanding is usually useful.



Diagnostics

- At almost any scale, optical diagnostics remain notoriously difficult.
 - Often impossible at too large a scale
- Prior to the 1990's:
 - Cold flow injector data was limited to about 400 psi or less
 - Hot fire data was limited largely to simple visualizations
- At present:
 - AFRL routinely characterizes injectors in cold flow at pressures up to 2000 psi.
 - Many examples of advanced diagnostics applied in hot fire exist



Diagnostics

The development of effective subscale methodologies has been as much about the development of diagnostics that work as it has been about injectors

- Most existing diagnostics have been developed for low pressure applications and have significant difficulties at high pressures.
- Much if not most of the effort in the 1990's was spent developing diagnostics for only one kind of injector – coaxial injectors



Characterizing rocket injectors at
AFRL

Uses of single element rocket injector measurements

- Understand physics
- Provide input to existing codes that require injector performance as an input
 - Need accurate data
- Validate codes
 - Need accurate data
- Evaluate particular injector designs
 - Not providing an answer is the same as letting the designer go with his/her existing superstitions
 - Need to consider the data together with all its uncertainties and still give the best possible guidance

AFRL full scale single element cold flow injector characterization facility

- Atmospheric tests are used to:
 - Check for manufacturing defects
 - Check out diagnostics
- Elevated chamber pressures are required to:
 - Prevent cavitation when at realistic pressure drops
 - Match more scaling parameters
- AFRL facility:
 - Chamber pressures to 2000 psi using water as a simulant.
 - Mechanical patterning at full pressure.
 - Full suite of optical diagnostics

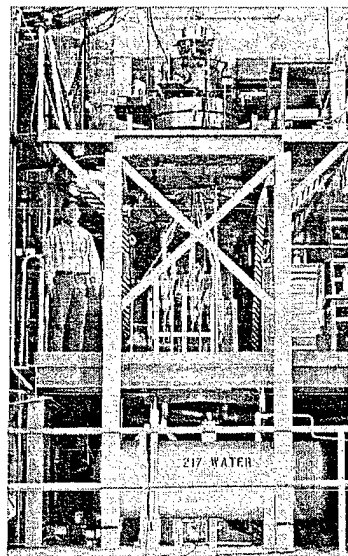

Pressure capability matches more scaling parameters

Atmospheric Pressure
 Geometry Scaling=1.0
 Velocity Ratio O/F=.084
 Ma=0.25

Pc=416 psig
 Geometry Scaling=1.0
 Velocity Ratio O/F=.084
 Ma=0.25
 Momentum Ratio O/F=.079
 Density Ratio O/F=29.2

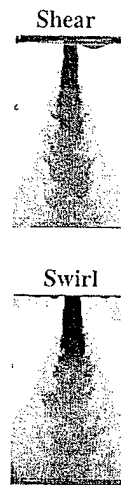
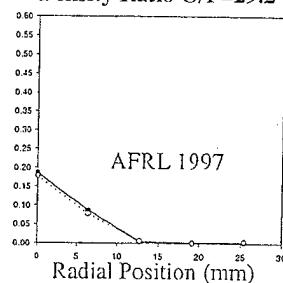
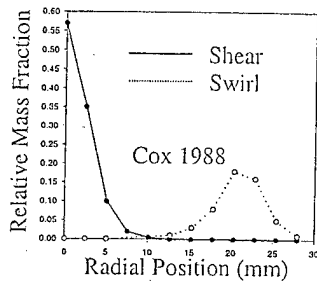

- SSME fuel preburner coax injector tests demonstrate reduced effectiveness of swirl on macro-scale mixing at pressure.

First step: always take a picture

GOX-centered swirl GOX/LHC injector
 outer liquid swirl flow only with core gas flow

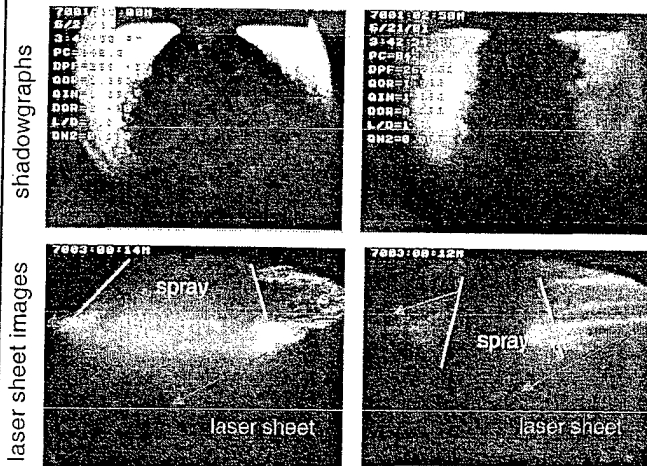

- Macro (shadowgraph, Schlieren, laser sheet)
 - Gross features
 - Relative fineness
 - Plan strategy
 - Videos usually sufficient
- Micro (sometimes)
 - Drop/blob sizes
- Sprays are almost always very dense
 - Light extinction often reaches 100%

Second step: mass distributions

- AFRL uses a traversable linear mechanical patternator to measure 2D mass flux distributions at pressure.
- Measuring collection efficiencies *a must*.
 - Liquid/liquid injectors: $\eta_{coll} = 80-90\%$
 - Gas/liquid injectors with large gas momentum: $\eta_{coll} = 30-50\%$
 - Current best practice is to correct patteration results by the collection efficiency
- In most cases we project that intrusive errors cause measured profiles to be smoother than they actually are.

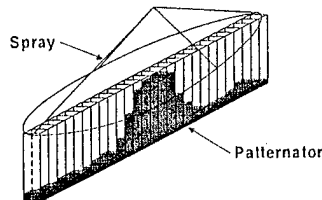
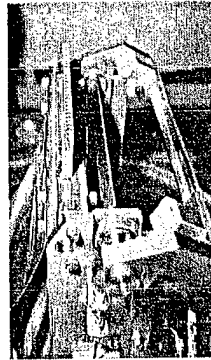

Optical patteration methods

Illumination of the spray with laser sheets

- Of qualitative value, but prone to quantitative errors in dense sprays
 - Extinction of the laser light
 - Attenuation of the signal light
 - Secondary scattering from particles outside the plane
- Significant advances in developing quantitative corrections were made in the 1990's, but these tend to remain insufficient for rocket applications

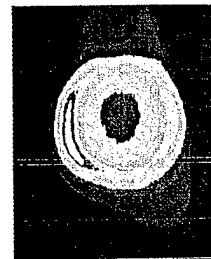
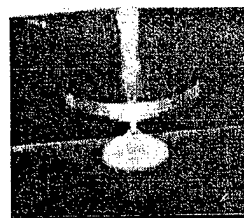

Errors caused by light extinction
(Illumination from left)

Third step: drop sizing and velocimetry

Categories of optical techniques

- Imaging (digital, film)
 - Image processors can perform focus discrimination by measuring edge gradients, and automatically measure sizes.
 - Depth-of-field depends on size; large drops preferentially sampled
 - Corrections can be made
 - Main advantage is ability to measure non-spherical droplets
 - Common in rocket sprays
 - Main disadvantage is slow sampling rates
 - Few significant advances in the 1990's except for faster computer speeds and increased resolution of CCD cameras.
- Phase Doppler interferometry (covered next)
- Forward scattering methods (covered next)

Phase Doppler interferometry

Droplet Size and Velocity

- Spatially and temporally resolved.
 - Single droplet counting technique.
 - Extension of the laser Doppler velocimetry technique.
 - Size range from 0.5 to 1000 μm (droplets must be spherical).
 - Up to three velocity components, droplet size and mass flux.

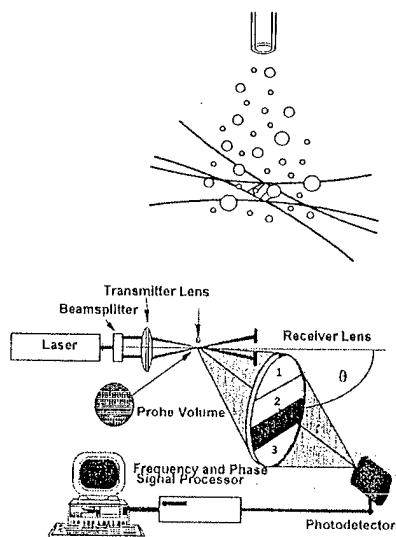

Phase Doppler interferometry

Simultaneous measurement of droplet size and velocity

- Phase shift proportional to droplet diameter.
 - 3 detectors yield 2 phase measurements.
 - Redundancy check
 - Prevents "wraparound"
 - Sphericity check
 - 160 MHz, 1-bit sampling, Fourier transform "real-time" processing.

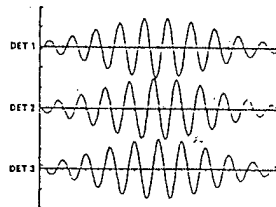

Figure 6. High pass filtered Doppler burst signals illustrating the phase shift

Bachalo and Husor, AIAA-84-1199, 1984

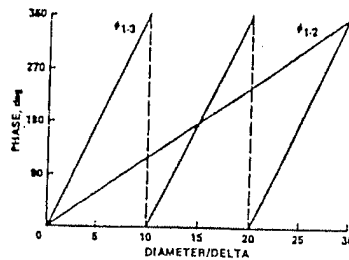

Figure 7. Phase/Doppler instrument response curve

Phase Doppler interferometry

Tracking "gas" and liquid phases

- For gas/liquid injectors, accounting for both phases is important
- With PDI, the smallest drop sizes can be assumed to mainly follow the gas. Therefore, filtering for the smallest drops traces the gas flow
 - Allows estimation of the mixture ratio

Non-spherical particles

- Size measurements don't work for non-spherical drops, and non-spherical drops are not always rejected by the signal processor
 - Photographic inspection of the measurement location should be performed to ensure that most of the droplets are spherical
- Valid velocity measurements are still obtained by operating the instrument as an LDV.

Phase Doppler Interferometry

Limitations in dense sprays

- Designed for "dilute" sprays.
 - Requires single droplet in the probe volume.
 - Beam waist usually much larger than maximum droplet size (uniform illumination).
- Dense sprays result in multiple droplet occurrences, beam attenuation and multiple scattering of signals.
- 1990's development - Reduce probe size to be much smaller than the largest droplet to be measured.

Technique works because only a fraction of the droplet surface is actually imaged into the receiver

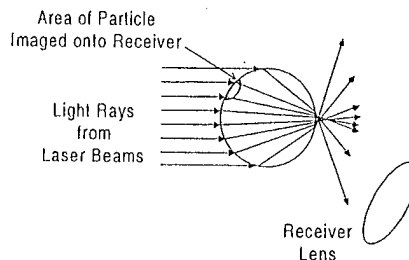

Phase Doppler interferometry

Small Probe Volume Technique

- Solving large probe volume problem creates another: Trajectory dependent scattering errors.
 - Uneven illumination can result in significant amounts of reflected light reaching the receiver.
 - Geometric optics modeling indicates that these errors can be rejected with intensity validation.

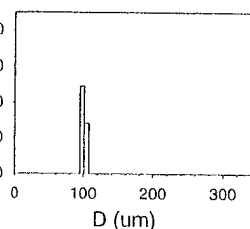
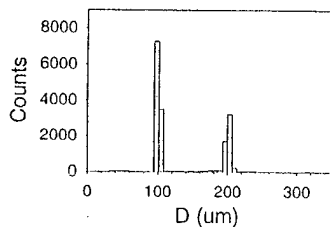

Model Calculations
D=100 μm
Random Trajectories

Light extinction

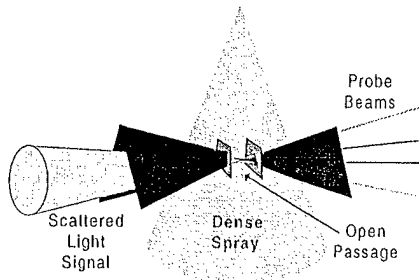

- Small probe volume technique is ineffective when light extinction reaches 100%.
- Preferred approach is to use beam guides / flow splitters.
 - Not always possible.
 - Flow effects assessed by noting trends as separation distance is varied.

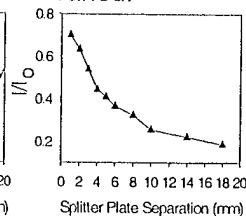
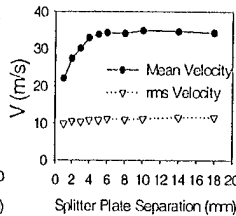
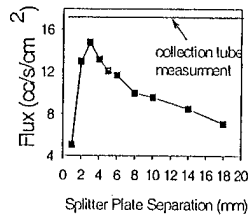

Phase Doppler interferometry

Small probe volume technique

- More complex than conventional PDI.
 - Requires simultaneous measurement of phase and peak scattered light intensity.
 - Small beam waist ($\sim 60 \mu\text{m}$) results in short transit times requiring high-speed data sampling (160 MHz).
 - Also requires a new method of probe volume correction (PVC) for accurate droplet sizing and mass flux measurements.
- Combined with a flow-splitter, the small probe volume technique can greatly improve accuracy of mass flux measurements in sprays with droplet number densities approaching 10^5 droplets/ cm^3 .

Phase Doppler interferometry

Effect of small probe volumes and flow splitters on measured mass fluxes

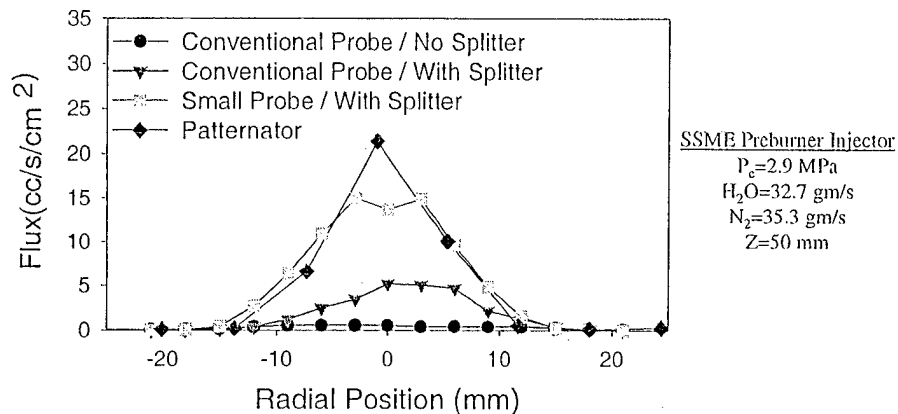

Forward scattering instruments

- Ensemble forward scattering
 - Yields droplet size distribution.
 - Transmissions down to 2% with multiple scattering correction.
 - Size range from 0.1 to 2000 μm (forgiving of slightly non-spherical droplets).
 - Droplet distribution calculated from inversion of light scattering distribution on a 31 ring detector.

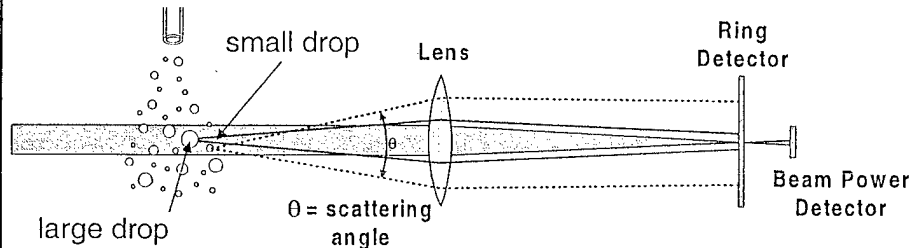

Forward scattering instruments

Ring Detector Approach

- Detector measures the diffraction pattern imaged by the Fourier transform lens.
 - Small droplets have large scattering angles.
 - Large droplets have small scattering angles.

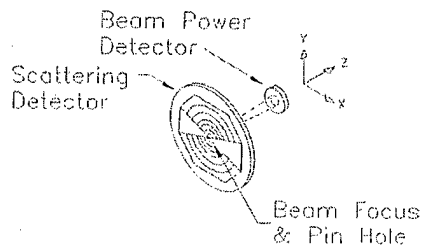

Mie Scattering Calculations
 $n = 1.33 - 0.0i$

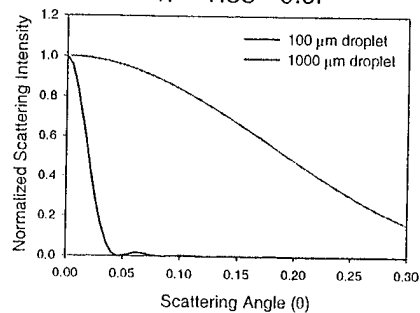

Forward scattering instruments

Scattering Theory

- Earlier instruments used Fraunhofer diffraction theory.
 - Limited to droplets much larger than the laser wavelength.
 - Fixed scattering cross-section ($C = 2 * A_{\text{cross-section}}$).
 - Does not account for anomalous diffraction (reflection + refraction).
- Newer instruments (1990's+) use Lorenz-Mie theory.
 - Mostly due to faster computers.
 - Eliminates limitations imposed by Fraunhofer diffraction theory.

Forward scattering instruments

Recent Advances

- Temporally resolved data (faster computers).
- Use of Mie scattering as opposed to Fraunhofer diffraction theory.
- Better multiple scattering corrections at large beam obscurations (model independent analysis).

Limitations

- Moderately dense sprays (Transmission > 2%).
- Can be sensitive to refractive index gradients (high-pressure & turbulent beam steering).
 - Depends on drop sizes
- Poor spatial resolution (line-of-sight, 10 mm beam diam.)

Forward scattering instruments

Dense spray corrections are used with forward scattering techniques

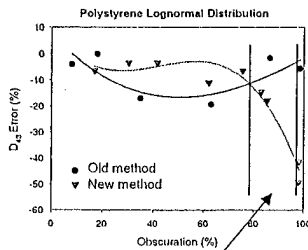

Regime often of interest

- Stirred cells of polystyrene beads currently being used to assess potential magnitude of errors.
- Approaches to index of refraction gradients masquerading as large droplets also being investigated.

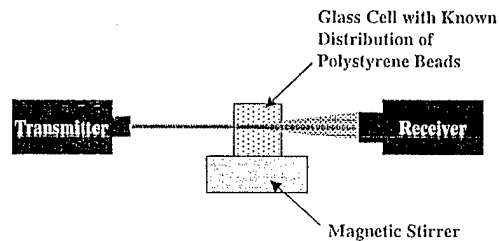

Forward scattering instruments

Beam wandering effects at high pressures

- Index of refraction gradients cause beam to wander off the center hole, hitting inner rings and appearing to be large droplets

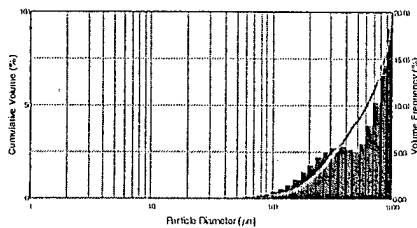

No saturation of gas with water vapor
Temperature control to +/- 7.0 C.

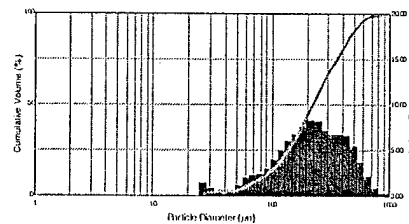

Saturation of gas with water vapor
Temperature control to +/- 0.7 C.

Forward scattering vs. PDI

Do forward scattering instruments and PDI give the same answer?

- Generally, no.
 - PDI is a point measurement (where the beams cross), while forward scattering is integrated along the length of the droplets in the beam.
 - PDI is flux-based, while forward scattering is volume-based
 - As a point measurement recording droplets going by a fixed location in space, PDI is biased towards size classes that are the fastest moving
 - Forward scattering is biased towards size classes that have the greatest number density in the beam at any given time.



Hot fire measurements

- Assuming windows are available in the combustion chamber (a non-trivial accomplishment), the same three steps generally apply, except:
 - Many diagnostics become significantly harder in hot fire; consequently, the range of choices becomes more limited.
- One silver lining is that hot fire tends to quickly burn off the fine particles.
 - Optical obscuration is sometimes improved



Hot fire measurements

- Measurements that have been relatively “straightforward” (i.e., difficult)
 - Visible emission
 - Shadowgraphy
 - Schlieren
 - Emission spectroscopy
 - Line-of-sight absorption
 - Disadvantages
 - ⊗ All these are line-of-sight
 - ⊗ Beam steering effects



Hot fire measurements

*Measurements that have been achievable
with significant difficulty*

- Velocimetry (laser Doppler velocimetry (LDV), particle imaging velocimetry (PIV))
- Phase Doppler interferometry
- Mie scattering
 - Location of liquids



Hot fire measurements

*Measurements that have been achievable
with great difficulty*

- Spontaneous Raman spectroscopy
 - Species concentrations
- Laser induced fluorescence (OH, CH, etc.)
 - Limited quantitative concentrations, but give reasonable locations of the flame front.
- Coherent anti-Stokes Raman Spectroscopy (CARS)
 - Species, temperatures



Major trend

Spontaneous Raman spectroscopy

- A weak effect where inelastic scattering causes a shift in wavelength by an amount dependent on the molecule.
 - Used primarily for species concentration measurements
- Signal strength proportional to density, inversely proportional to the fourth power of the wavelength
 - Favors high pressures and blue and UV wavelengths
 - Works best in single-phase flows; multiphase effects cause interference.
- Most of the major labs have developed this diagnostic.



Case study: gas/gas injector
development



Gas/gas injectors

- Two reasons to study gas/gas injectors
 - Motivated by US interest in a full flow staged combustion cycle
 - ◊ Required a gas/gas main injector to be developed at a size for which the US had no experience
 - Logical first step for research
 - ◊ Tendency to model or measure gas/gas first before introducing the potential complications of multiphase flows
- The Gas/Gas Injector Technology program (GGIT) was initiated in the mid 90's by a team composed of government, industry, and university.
- The effort attempted to combine data obtained at different scales with CFD to develop a design for the injector
 - Tucker, et. al., paper AIAA 97-3350.



GGIT objectives

- Provide Rocketdyne with data on candidate gas/gas injector designs for its planned FFSC engine (RS-2100)
- Develop a national gas/gas database
- Validate CFD codes for future gas/gas injector design

The team evaluated designs which were proprietary to Rocketdyne and other designs which were in the public domain

GGIT team responsibilities

- Rocketdyne Propulsion and Power (RPP)
 - Provided overall technical leadership
 - Designed and fabricated proprietary injector prototypes
 - Internally funded its own participation
- Penn State (PSU)
 - Evaluate propellant mixing and combustion of a single injector elements (uni-element testing)
- NASA Lewis (LeRC)
 - Evaluate propellant mixing and combustion of a multiple element injectors (multi-element testing)
- NASA Marshall (MSFC)
 - Managed overall funding and coordination
 - Performed CFD modeling.

GGIT design logic

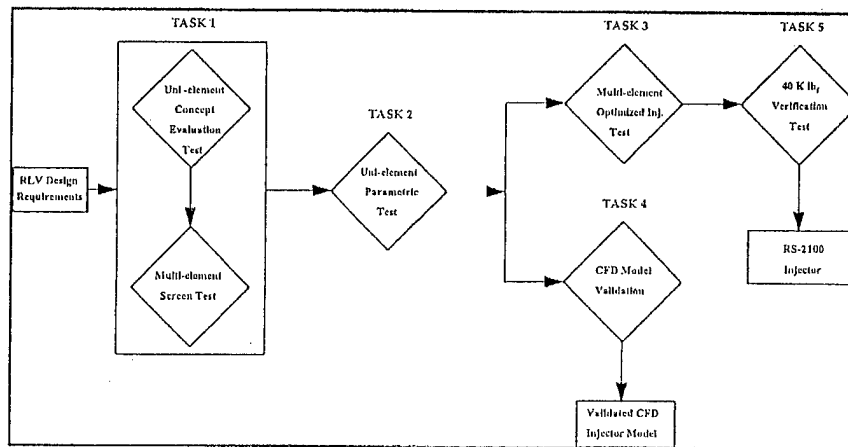

Figure 3. Gas-Gas Injector Technology Project Logic Diagram.

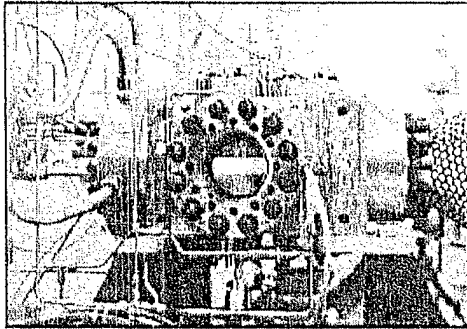

Figure 2. Gas-Gas Multi-Element Hot-Fire Test in the Rocketdyne Chamber at LeRC.

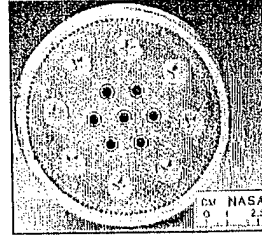

Figure 7. Team Multi-Element Shear Coaxial Injector

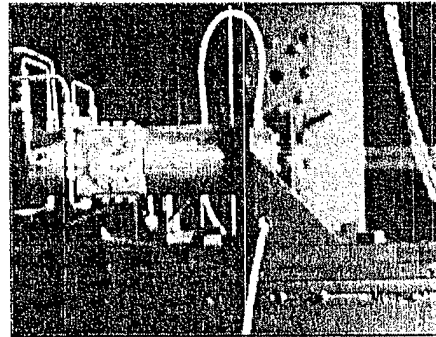



Figure 1. Gas-Gas Uni-Element Hot-Fire Test in the Optically Accessible Chamber at PSU.

GGIT results

- The program was discontinued before completion because the FFSC concept was not downselected for RLV
 - X-33 / Venture Star was
- Several proprietary and public injectors were uni-element tested.
- Only the proprietary injectors were fired as multi-elements



GGIT impact

- RPP used lessons learned in GGIT to demonstrate the combined firing of an ox rich preburner and a gas/gas main injector
 - Ref: Farhangi, et. al., paper AIAA 99-2757.
- RPP designed the main injector for the Air Force's Integrated Powerhead Demonstrator engine partially using GGIT results.
 - This engine is still under active development, and has not yet been fired.
- A data set survives for a gas/gas coaxial element that has been used as a benchmark case for model development.
 - Foust, et. al., paper AIAA 96-0646.



Gas/gas CFD modeling

- The Penn State coaxial gas/gas data has been modeled by several groups
 - Merkle code, Penn State
 - AS3D code, DLR, Germany
 - FDNS code, MSFC
 - CFD++ code, AFRL
 - Schley, et. al., paper AIAA-97-3350
 - Archambault, et. al., papers AIAA-2002-1088 and AIAA-2002-3594
- All exhibited comparable, although different, agreement with the data.
 - Only the AFRL results will be presented here

2002-1088
AIAA-2002-3594
9-000
2002-1088

Penn State configuration

- OH-radical imaging
- Velocity & species field (Raman) measurements

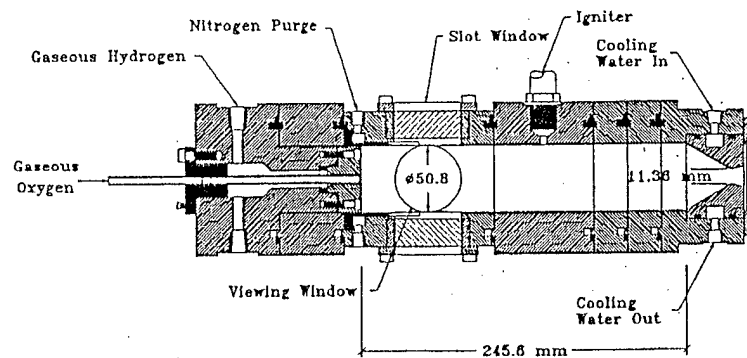

Computational configuration

- Solution exhibited extremely slow convergence with large residuals
 - Due to the attempt to force a steady solution on an inherently unsteady flow
- Subsonic injector flow meant that pressure waves inside the injector must be modeled
- Many tricks required to obtain solution
- Objective: compare steady solution with a time-averaged unsteady solution

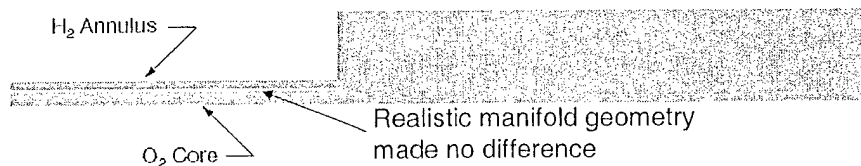

Axisymmetric results

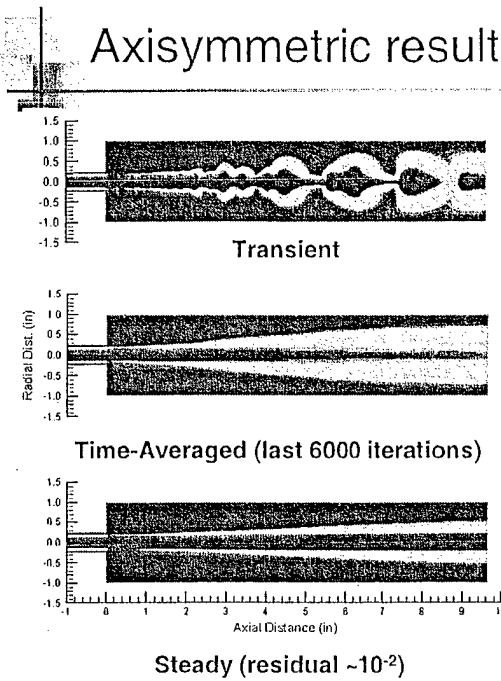

- Steady solution obtained in ~6000 iterations. 18,000 time-accurate iterations performed after steady state reached.
- Independent of initial conditions at 12000 iterations.
- OH concentration contours demonstrate differences between steady and transient solutions.
- Steady solution does not capture the effects of the flapping flame.

Comparisons with data

H₂ Mole Fraction

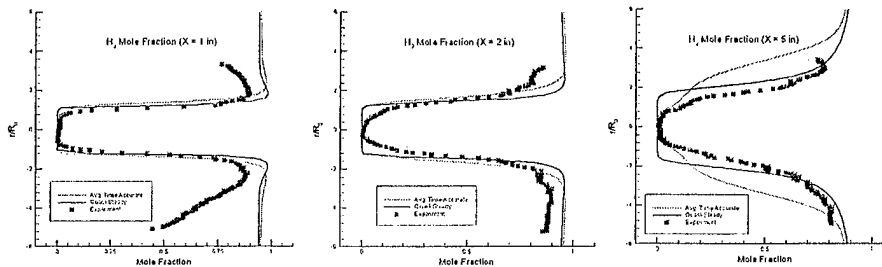

- Gaseous nitrogen curtain purge in experiment not modeled. This accounts for decrease in H₂ experimental mole fraction near walls in the data. Possibly also accounts for computed profiles broadening more rapidly than experimental data
- Steeper computational profiles may be due to unsteadiness in the experimental shear layer

Comparisons with data

O₂ Mole Fraction

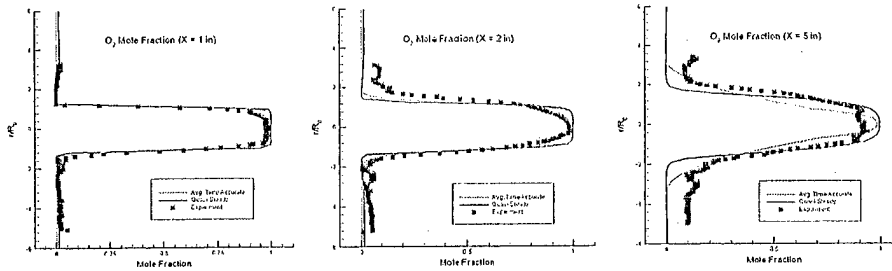

- Oxygen does not radially diffuse as does the hydrogen with downstream distance.
- O₂ and H₂ mole fraction calculations agree with data about as well as other reported results.

Comparisons with data

Mean Axial Velocity (m/s)

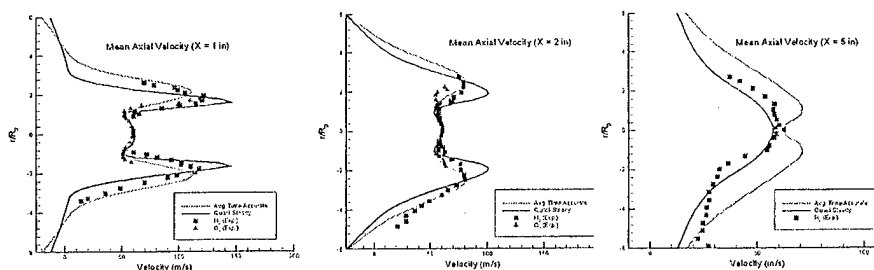

- Time-averaged peak velocities better match data than steady velocities near the injector. Full geometry of injector manifold was modeled to see if better agreement could be obtained, but no significant improvement was observed.

Comparisons with data

RMS Axial Velocity (m/s)

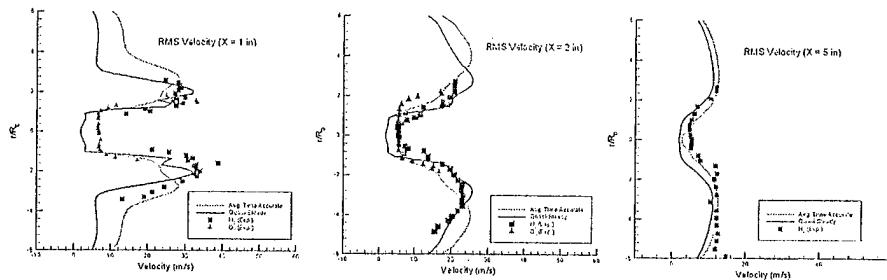

- Steady and time-averaged results compare about equally well with experiment.
- Differences in inlet turbulence boundary conditions may likely have a significant effect on RMS values.

Effect of window purge (axisym.)

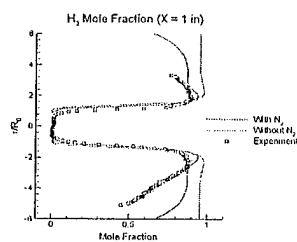

- Not modeling purge could partially explain earlier disagreements
- Axisymmetric purge computed here is only partially realistic
 - Real purge was on only one side of a square chamber
 - Realistic model requires 3D

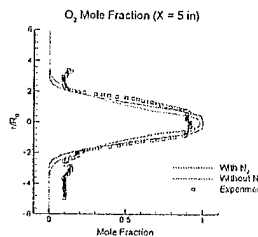
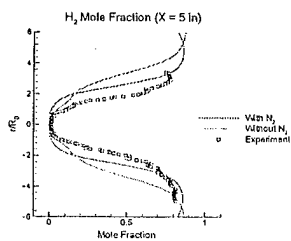

Effect of turbulence model

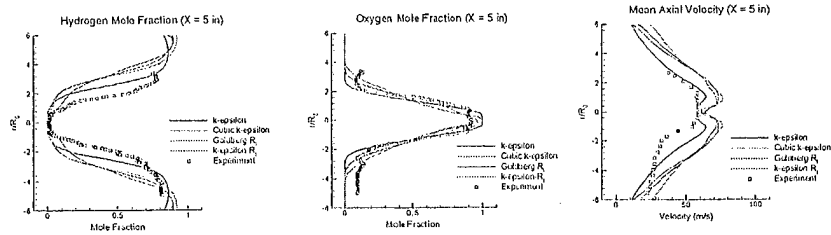

- The effect of the turbulence model is not small
- Should use a model appropriate for shear layers

Summary of gas/gas CFD

- Few shortcuts appear to be possible if one is to truly compare experiments with CFD.
- Range of variation suggests that steady and transient 3D computations should also be investigated
 - Underway at AFRL



Other available data sets

- Focus of the 2nd International Workshop on Rocket Combustion Modeling, 25-27 March 2001, Lampoldshausen, Germany.
 - Data set RCM – 1: Round liquid nitrogen jet injected into gaseous nitrogen (no combustion) at 3.97 and 5.98 MPa.
 - Data set RCM – 2: Coaxial LOX/H₂ combustion at 1 MPa.
 - Data set RCM – 3: Coaxial LOX/H₂ combustion at 6 MPa.

- Conference results:
 - Reasonable ability to model RCM – 1.
 - Questionable ability to model RCM – 2 and RCM – 3.



Injection at supercritical pressures

The problem

- Rocket combustion chambers often operate at pressures exceeding the critical pressure of one or more propellant, such as LOX.
- At supercritical pressures, the distinct difference between gas and liquid phases disappears.
 - Conventional “spray combustion” experience no longer applies.
- It is not known how to replace conventional “spray combustion” models in engine design codes.
 - *The lack of understanding leads to potentially large engine design errors.*

The problem

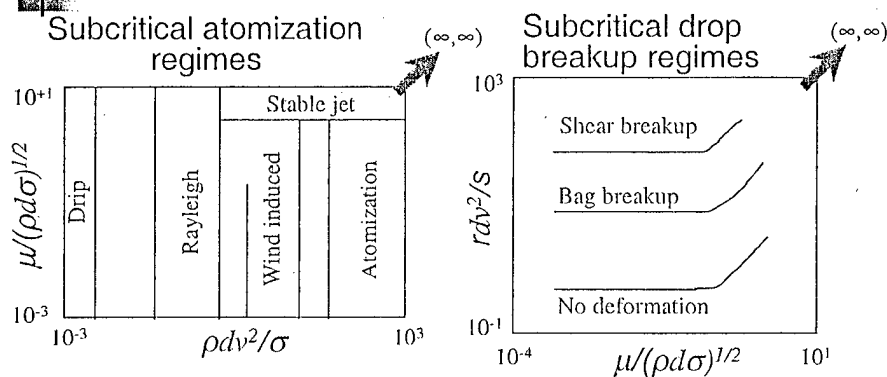

Surface tension σ vanishes at supercritical conditions. Conventional atomization and breakup parameters become *infinite*, where no data exists.

Supercritical atomization and breakup regimes are largely unknown

The problem

Other factors not normally considered in conventional spray combustion

- Vanishing surface tension and enthalpy of vaporization.
- Equivalent "gas" and "liquid" phase densities.
- Strongly enhanced solubility of one species ("gas") into another ("liquid").
- Reduced "gas" phase diffusivity (more liquid-like).
- Large property excursions near the critical point
 - Conductivity, viscosity, speed of sound, specific heats.
- Mixing induced critical point variations.
- Enhanced gas phase unsteadiness.
- Potentially different kinetics mechanisms.

AFRL facility

- Windowed pressure vessel operating at supercritical pressures.
- Cryogenic fluid capability (LOX, LN₂)
- Capability to produce supercritical droplets and jets.
- Shadowgraph, Schlieren, and Raman visualization of concentration fields.
- Capability to drive flows with an acoustic driver

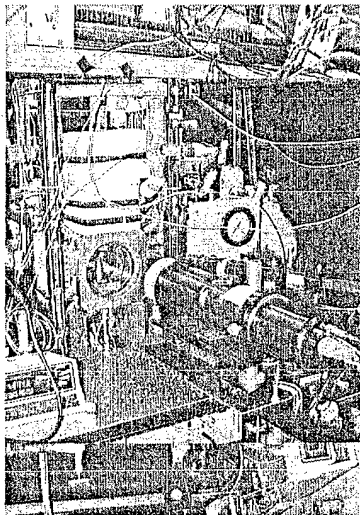

Low Reynolds number jet results

Low Reynolds
Number
Cryogenic Jets

Shadowgraph images of
liquid nitrogen jets is-
suing into a pressurized
chamber.

Inj. diam: 0.25 mm

Re: 3350 - 4090

LN2 Temp: 87K

Chamb. Temp: 292K

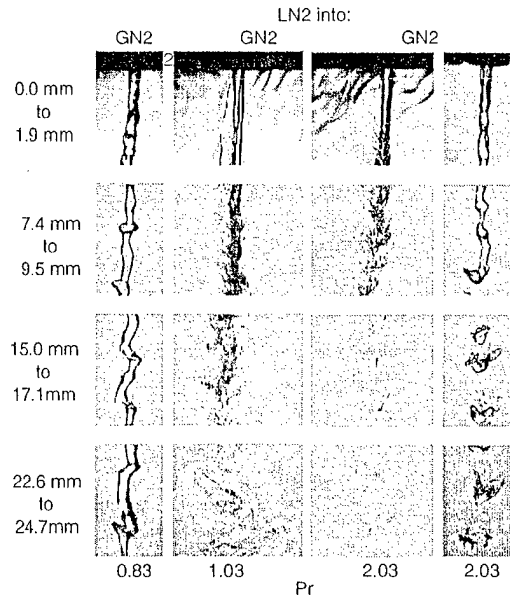

High Reynolds number jets

$P_{cr} = 3.39 \text{ MPa}$

$T_{amb} = 300 \text{ K}$

$Re = 25,000 - 75,000$

$T_{inj} = 126 \text{ K}$

$T_{inj} = 99 - 120 \text{ K}$

$\dot{V}_{inj} = 10 - 15 \text{ m/s}$

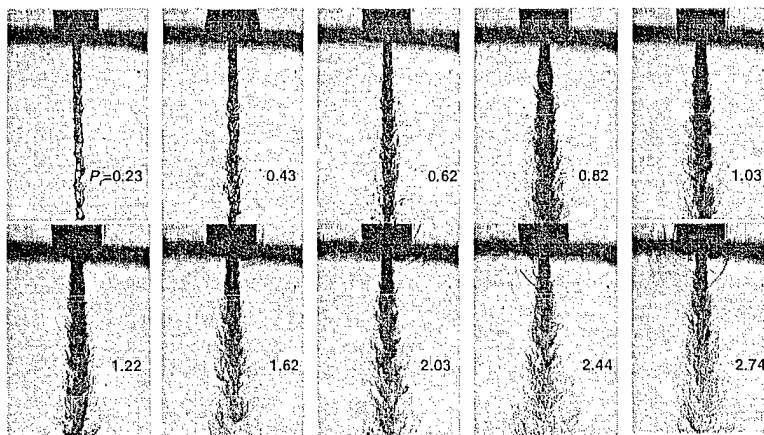

Jet Spreading Angles

- Steady Diesel-Type Spray L/D=4 (Reitz and Bracco)
- Steady Diesel-Type Spray L/D=85 (Reitz and Bracco)
- N2 jet into N2 L/D=200 (*)
- ◇ N2 jet into N2 Darkcore (*)
- ◆ Cold He jet into N2; L/D=200 (*)
- Cold N2 jet into He; L/D=200 (*)
- × Brown & Roshko (He/N2)
- △ O2 jet into N2; L/D=200 (*)
- O2 jet into N2; Darkcore (*)
- Theory (Papamoschou&Roshko)

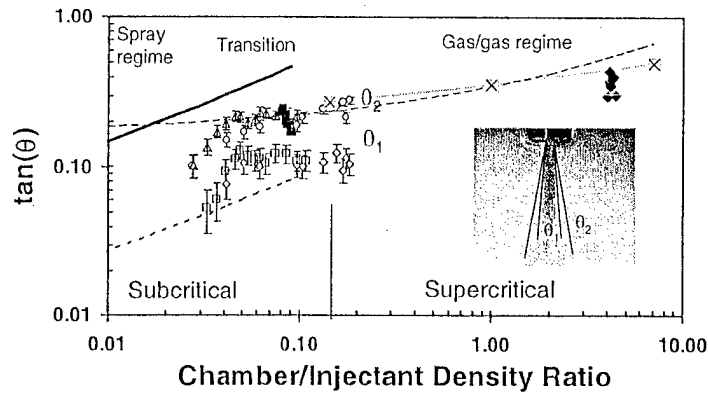

Mixing layer structure

$P_{cr} = 3.39 \text{ MPa}, T_{cr} = 126 \text{ K}, T_{inj} = 128 \text{ K}, T_{amb} = 300 \text{ K}$



*Low Pres.
Subcritical
Droplets*

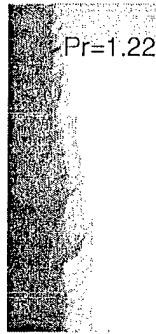

*Mod. Pres.
Supercritical
Transition*

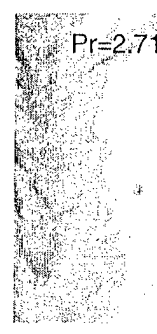

*High Pres.
Supercritical
Gas layers*

Empirical model

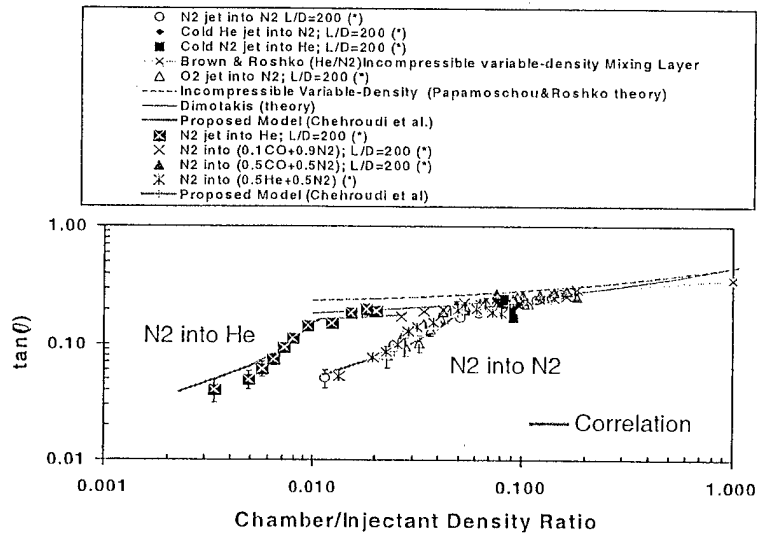

Gas-like behavior of supercritical jets

- It has quantitatively shown that supercritical jets behave like low Mach number variable density jets in several respects
 - They have the same appearance
 - They spread at the same rate
 - They have the same fractal dimension
- Thus there is a reasonable expectation that “conventional” turbulence research on low Mach number variable density jets will apply to supercritical jets

Instantaneous Images of Sub- and Super-critical Impinging Jets

N_2 into N_2
($P_{critical} = 3.39$ MPa; $T_{critical} = 126.2$ K)
($Re=25,000$ to $70,000$; injection velocity: $10-15$ m/s)
(Side-on view)

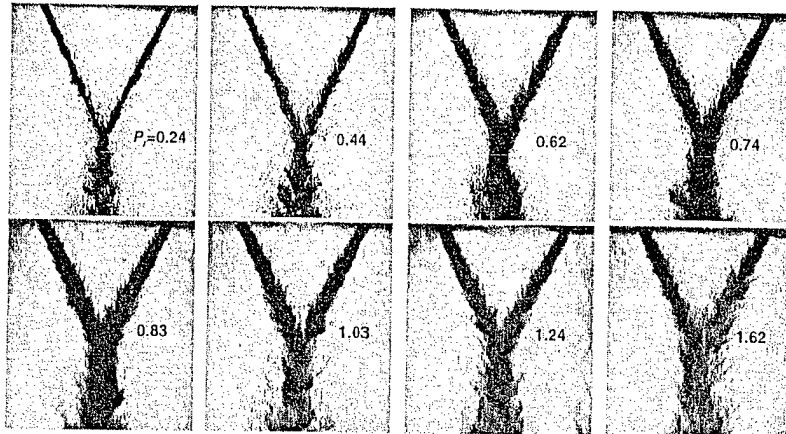

Instantaneous Images of Sub- and Super-critical Impinging Jets

N_2 into N_2
($P_{critical} = 3.39$ MPa; $T_{critical} = 126.2$ K)
($Re=25,000$ to $70,000$; injection velocity: $10-15$ m/s)
(90 degree rotation)

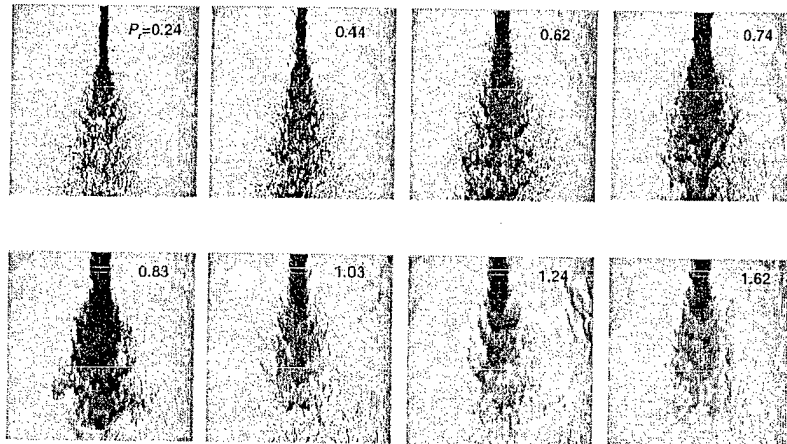

Acoustic results

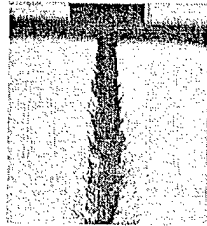

Acoustic waves impinging on jet

Cryogenic cooler

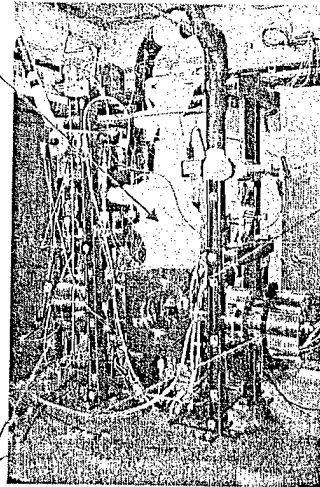

Windowed pressure vessel

Acoustic drivers

Acoustic results

LN2 into GN2

SPL = 140 – 189 dB

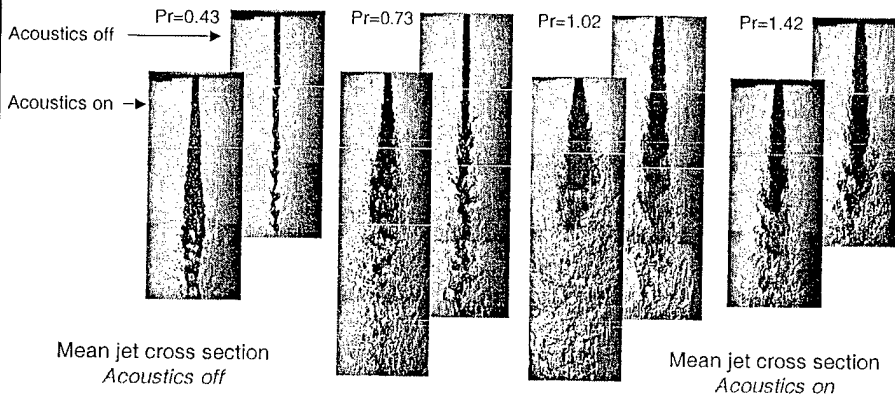

Mean jet cross section
Acoustics off

Mean jet cross section
Acoustics on

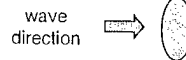

Jet deformation mechanism

Bag breakup of drops

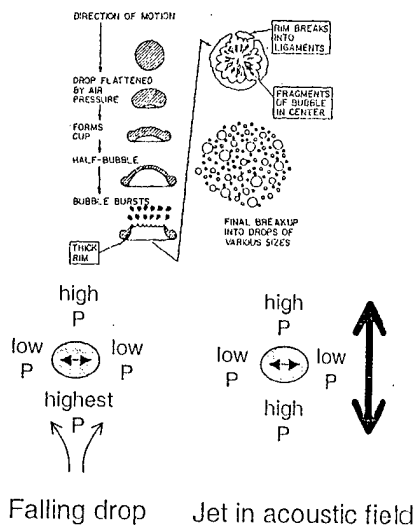

- Drops flatten perpendicular to the flow before breaking up because the higher velocities around the shoulders cause lower pressures there due to the Bernoulli effect.
- Similar pressure imbalances are set up, *in the mean*, around a jet (or drop) in an acoustic field.
- Therefore the jet deforms in the mean.

Main Conclusions from Acoustics Observations

- The effect of acoustics:
 - is largest near the critical pressure.
 - is strong at subcritical pressures.
 - decreases to negligible at supercritical pressures
- The effect of acoustics decreases at all pressures as jet velocity increases (residence time in the acoustic field decreases)

Conjecture

- Being in a supercritical regime may reduce the ability to couple with acoustic instabilities.

Transcritical LN2 drops in room temperature
GN2

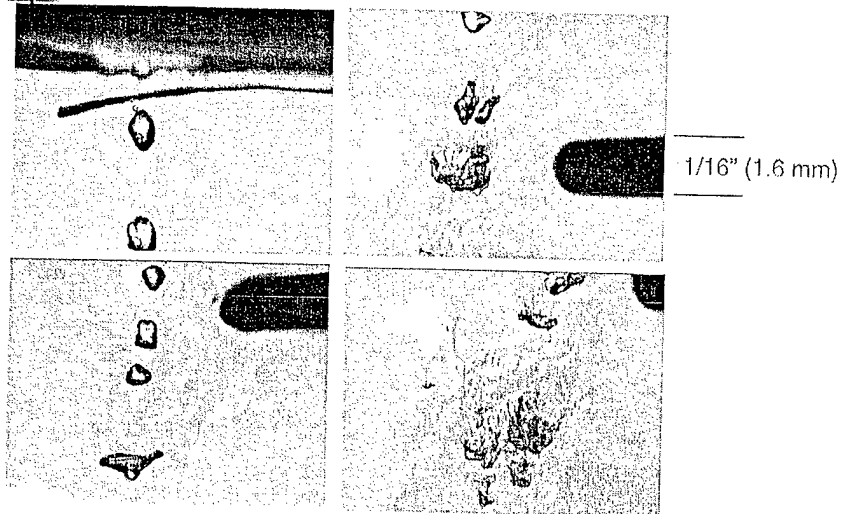

Representative evolution of transcritical drop disintegration

Messages from beyond?

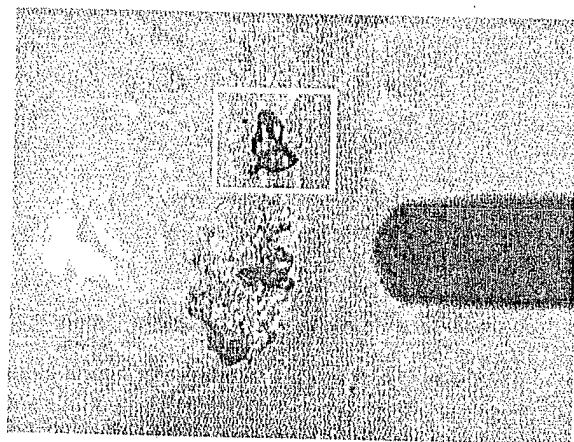

Super-critical natural droplets?