



MEMORANDUM FOR PRS (In-House Publication)

1011CAGF

FROM: PROI (STINFO)

06 May 2002

SUBJECT: Authorization for Release of Technical Information, Control Number: **AFRL-PR-ED-TP-2002-100**  
Tim Miller (PRSM) et al., "An Investigation of Interfacial Fracture Using Experiments, Modeling, and Simulation"

**Society for Experimental Mechanics**  
**(Milwaukee, WI, 11 June 2002) (Deadline: 30 May 2002)**

**(Statement A)**

1. This request has been reviewed by the Foreign Disclosure Office for: a.) appropriateness of distribution statement, b.) military/national critical technology, c.) export controls or distribution restrictions, d.) appropriateness for release to a foreign nation, and e.) technical sensitivity and/or economic sensitivity.

Comments: \_\_\_\_\_  
\_\_\_\_\_  
\_\_\_\_\_

Signature \_\_\_\_\_ Date \_\_\_\_\_

2. This request has been reviewed by the Public Affairs Office for: a.) appropriateness for public release and/or b) possible higher headquarters review.

Comments: \_\_\_\_\_  
\_\_\_\_\_  
\_\_\_\_\_

Signature \_\_\_\_\_ Date \_\_\_\_\_

3. This request has been reviewed by the STINFO for: a.) changes if approved as amended, b) appropriateness of references, if applicable; and c.) format and completion of meeting clearance form if required

Comments: \_\_\_\_\_  
\_\_\_\_\_  
\_\_\_\_\_

Signature \_\_\_\_\_ Date \_\_\_\_\_

4. This request has been reviewed by PR for: a.) technical accuracy, b.) appropriateness for audience, c.) appropriateness of distribution statement, d.) technical sensitivity and economic sensitivity, e.) military/national critical technology, and f.) data rights and patentability

Comments: \_\_\_\_\_  
\_\_\_\_\_

APPROVED/APPROVED AS AMENDED/DISAPPROVED

\_\_\_\_\_  
PHILIP A. KESSEL Date  
Technical Advisor  
Space and Missile Propulsion Division

# **An Investigation of Interfacial Fracture Using Experiments, Modeling, and Simulation**

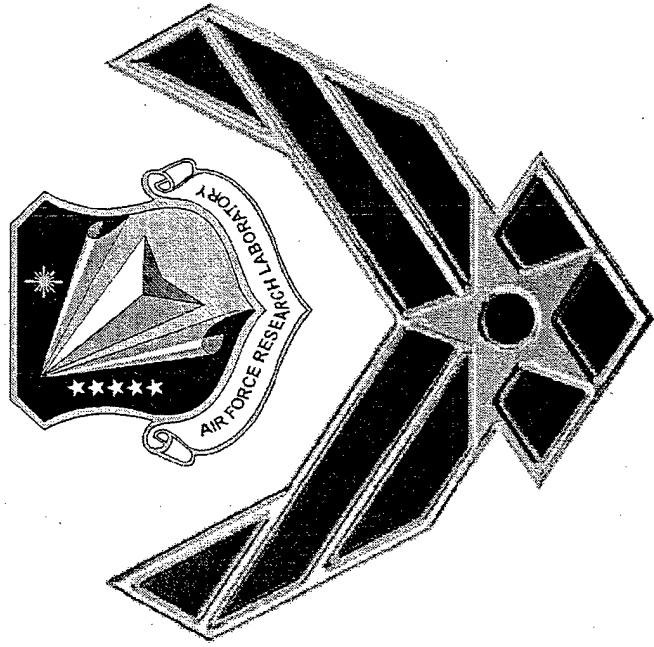

**T. C. Miller, Air Force Research Lab**

**E. Guan, SUNY Stony Brook**

**J. Todaro, SUNY Stony Brook**

**SEM Annual Conference**

**June 11, 2002**

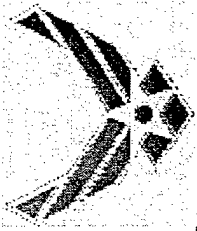

# Introduction



- Importance of Problem
- Problem Statement
- Technical Approach

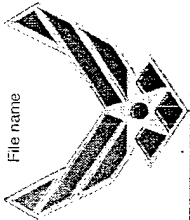

# Importance of Problem

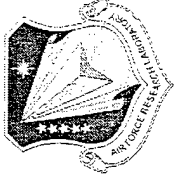

- High cost and complexity of modern rocket systems provide multiple possibilities for failure, any one of which could result in lost lives and large capital losses.
- One failure mode involves deterioration of the layered materials near the inside of the rocket motor case.

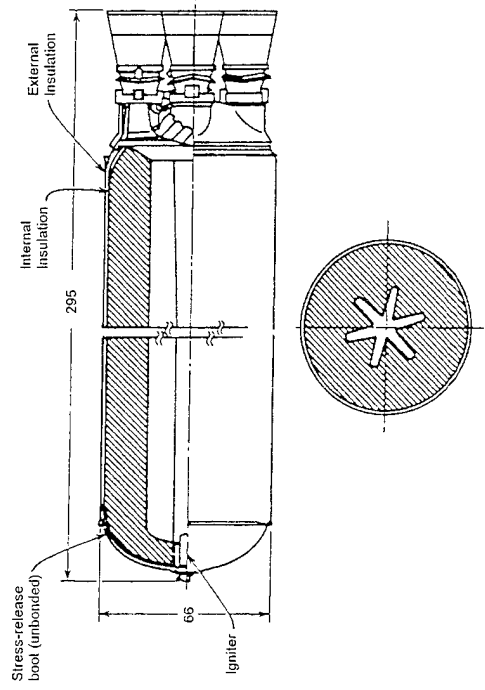
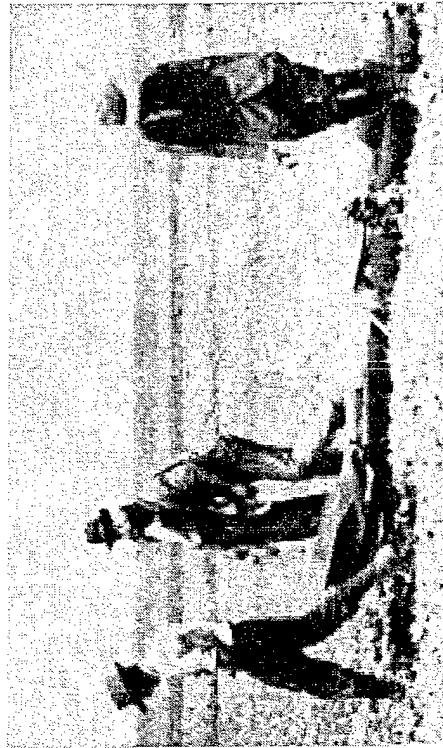

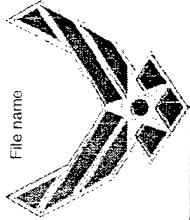

# Problem Statement



- Rocket motor incorporates four layers of materials.
- Each layer contributes to motor performance in some significant way, but adds complexity and increases the number of potential failure locations.
- One area that has caused problems is near the liner-propellant interface, which can have defects originating and evolving during the manufacturing, storing, handling, or launching of the rocket.
- Fracture mechanics of defects near these interfaces is not well understood. Nonlinear material behavior, property gradients, large deformations, and the damage in particulate composites all affect the mechanical behavior.

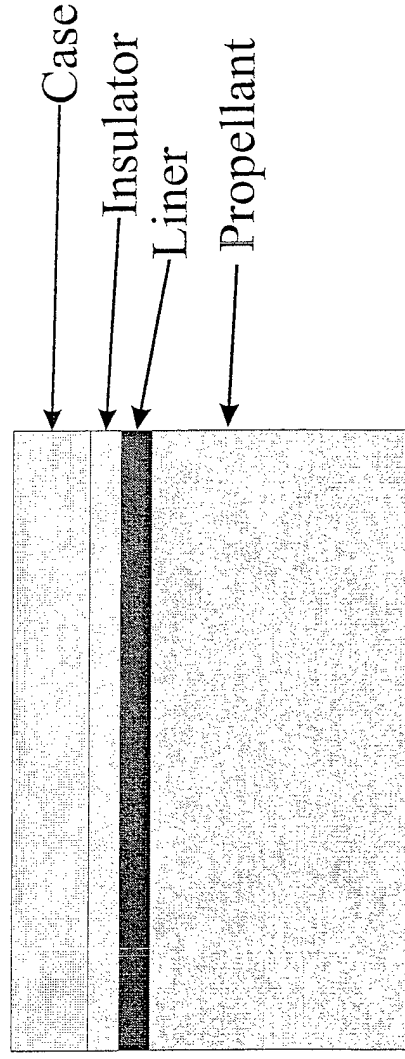

Inner bore of rocket

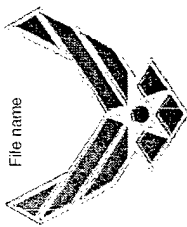

File name

# Technical Approach

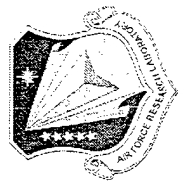

Initial experiments use a combination of speckle interferometry and computational modeling to examine a bimaterial specimen without cracks.

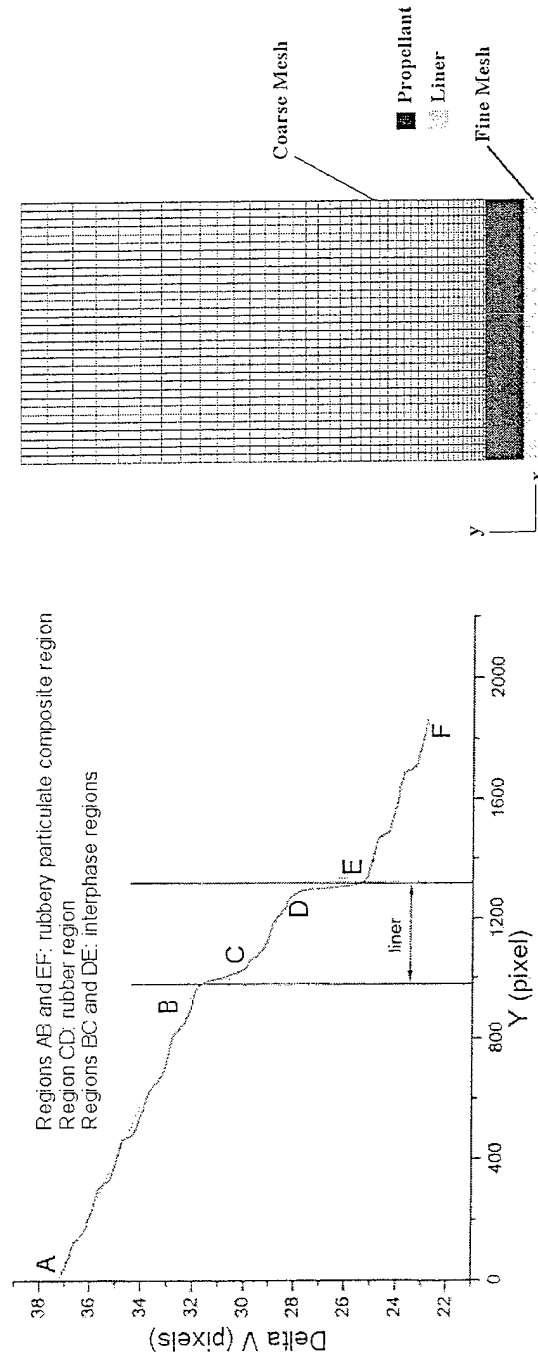

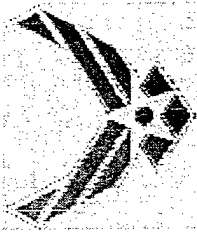

# Experimental Equipment and Procedures

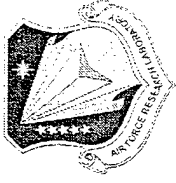

- Equipment
- Procedures

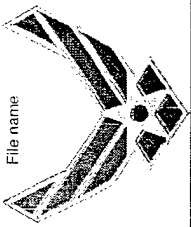

File name

# Equipment

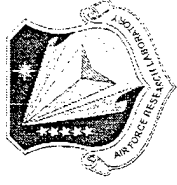

- Tensile testing machine deformed the bimaterial specimens while simultaneously capturing images using a charge-coupled device (CCD) camera.
- Specimen images were analyzed using the Computer-Aided Speckle Interferometry (CASI) method.
- Images used to determine the displacement of the specimen edges and the two rubber-RPC interfaces. These were the basis for the average strain measurements and the associated strain rate measurements shown later in the Discussion section.

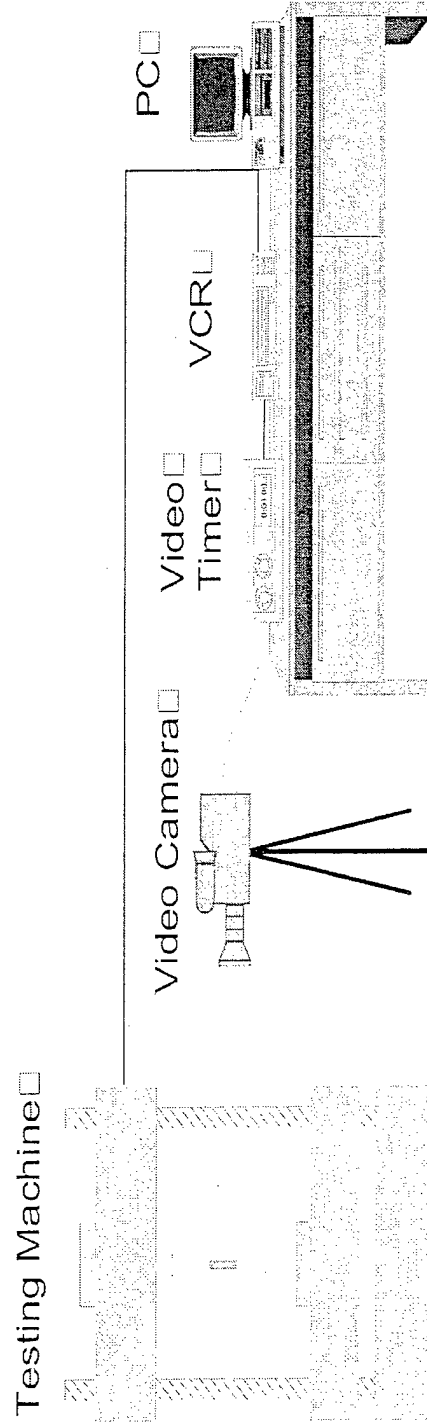

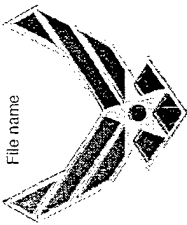

File name

# Procedures



- Typical specimen shown below.
- Thin liner layer (2.54 mm) sandwiched using thin layer of urethane adhesive (avoids property gradients).
- Application involved other materials as well.
- We used aluminum grips and a screw driven tensile testing machine.
- Specimen width was varied as shown in the table. For the figures shown in the Discussion section, the results are for a specimen with a width of 25.4 mm.

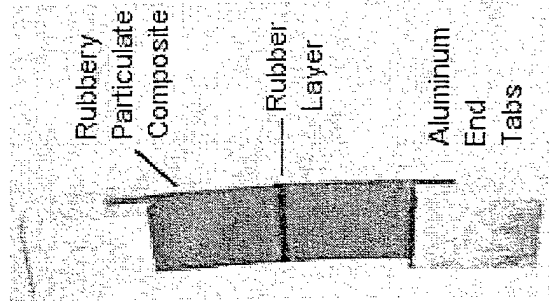

Specimen Width (mm)	Specimens Tested
25.4	2
12.7	9
5.08	2

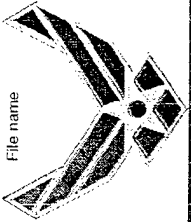

# Procedures

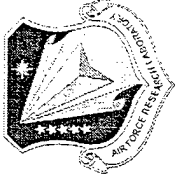

Images also used to determine relative displacements of the two interfaces and the specimen top and bottom edges, giving average strain values. These were then used to get strain rates as a function of time using a simple finite difference formula.

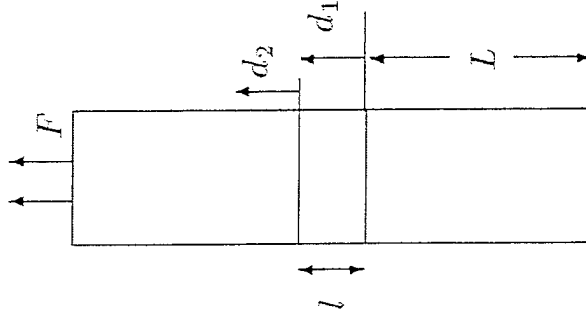

$$\varepsilon_{RPC}^L = d_1 / L$$

$$\varepsilon_{rubber}^L = \frac{(d_2 - d_1)}{L}$$

$$\varepsilon_{RPC}^E = \frac{d_1}{L + d_1}$$

$$\varepsilon_{rubber}^E = \frac{(d_2 - d_1)}{(l + d_2 - d_1)}$$

$$\frac{\partial \varepsilon}{\partial t}(t = t_i) = \frac{\varepsilon_{t_{i+1}} - \varepsilon_{t_i}}{t_{i+1} - t_i}$$

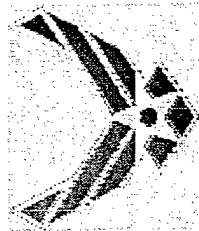

# Computational Modeling

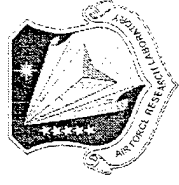

- **Constitutive Modeling**
- **Mesh and Boundary Conditions**

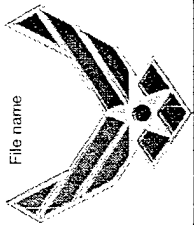

# Constitutive Modeling of Propellant

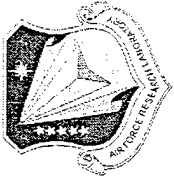

- Specimens were rectangular. Gage length and crosshead speeds designed to match bimaterial test specimen strain rates during first 10 minutes of deformation.
- Material experiences relatively small strains and was therefore modeled as linear elastic. Results: Young's modulus = 6.474 MPa and  $\nu = 0.499$ .

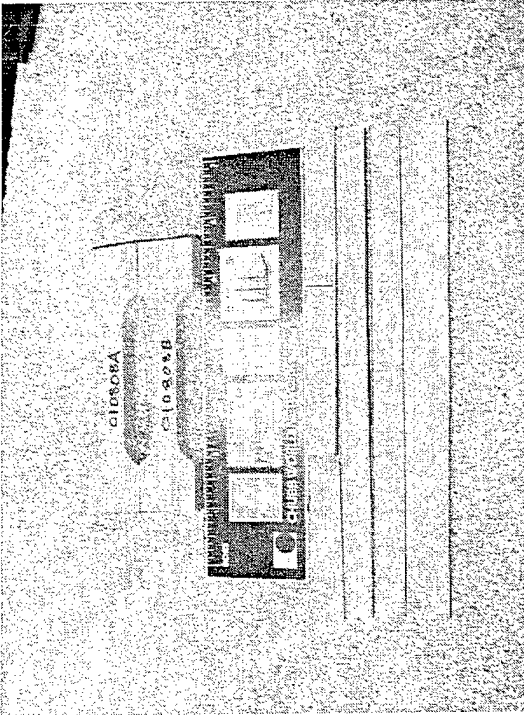

Specimen	Type	comments	GL [cm]	W [cm]	t [cm]
010808A	Dogbone	bimat block	6.985	1.270	0.930
010808B	Dogbone	bimat block	6.985	1.270	0.956
010813A	rectangle	other block	6.604	1.331	0.508
010813B	rectangle	other block	6.604	1.306	0.508
010815A	rectangle	other block	20.32	1.427	0.508
010815B	rectangle	other block	20.32	1.270	0.508

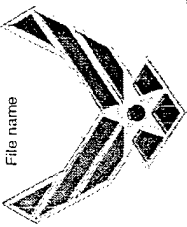

# Propellant Modulus Results

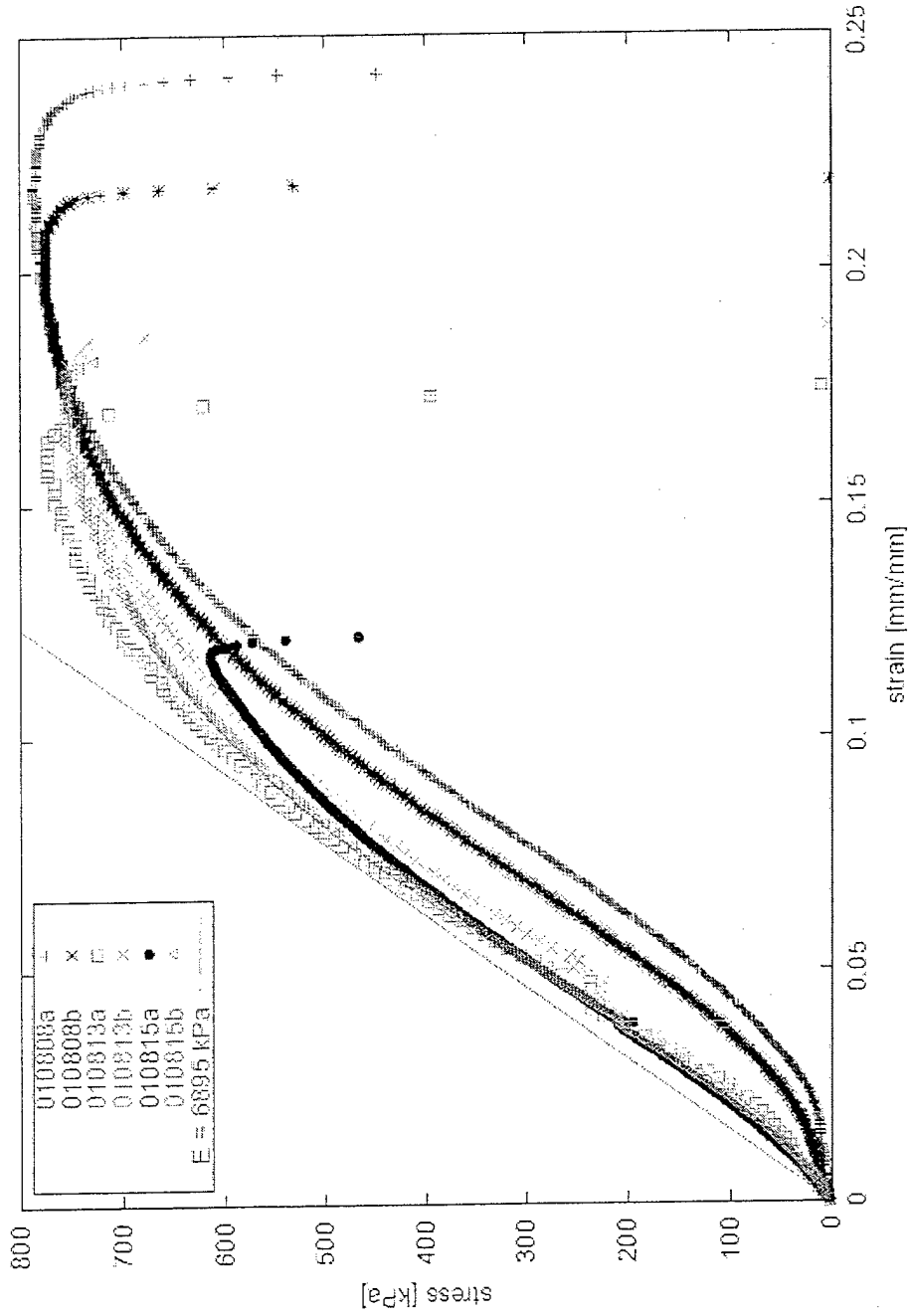

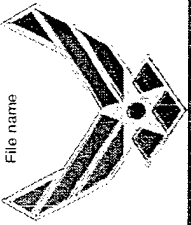

# Constitutive Modeling of Liner

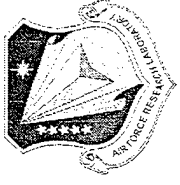

- Liner material experiences much larger strains during specimen deformation (about 0.7-0.8 mm/mm by the end of the test), so the nonlinear aspects of the problem had to be considered.
- Ramberg-Osgood curve fit used. It addresses nonlinearities due to large strains, but does not address the strain rate dependence of the stress-strain curve.
- Three dogbone shaped rubber specimens were cut from a sheet and tested (nominal dimensions were 69.9 x 4.2 x 9.5 mm).
- Procedure for Ramberg-Osgood curve fit:
  - Use average curve of three specimens for curve fitting purposes.
  - Use true stress and strains.
  - Determine the linear region and the modulus for this region, then find the yield point.
  - Take logarithms of the Ramberg-Osgood equation then determine the exponent and  $\alpha$ .

$$\frac{\epsilon}{\epsilon_0} = \frac{\sigma}{\sigma_0} + \alpha \left( \frac{\sigma}{\sigma_0} \right)^n$$

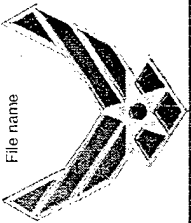

# Ramberg-Osgood Curve Fit Results

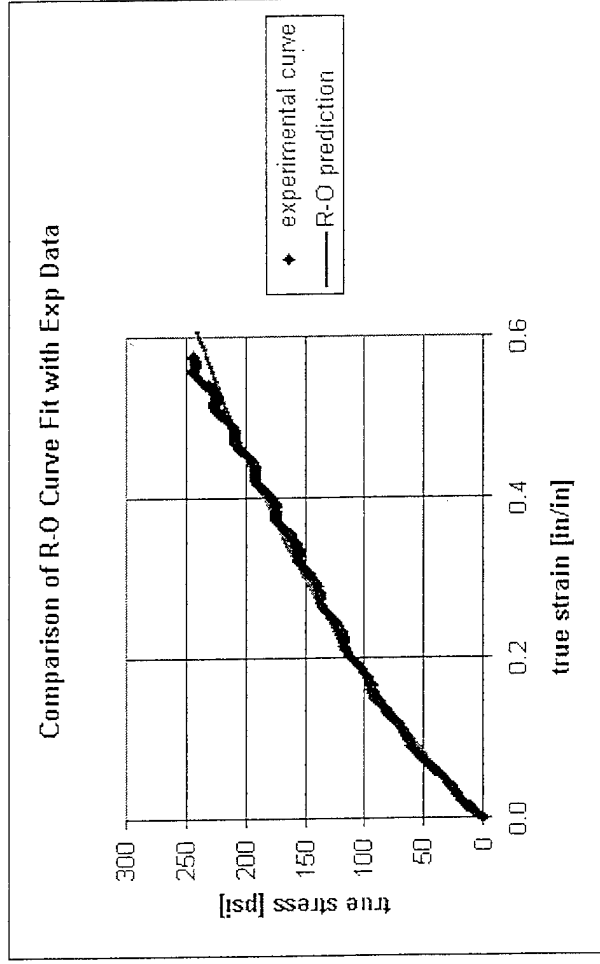
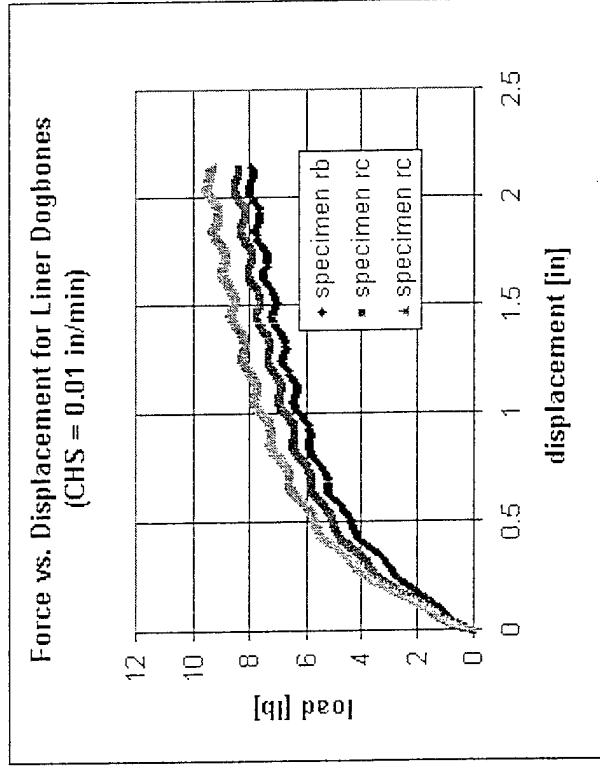

Parameter	Value
Modulus [psi]	625.0
Poisson's ratio	0.499
yield stress [psi]	95.41
exponent	2.41
coefficient	0.1111

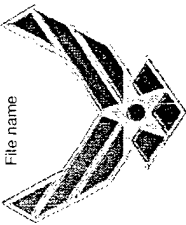

File name

# Mesh and Boundary Conditions

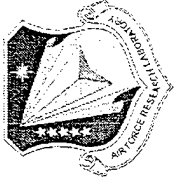

- Four meshes of varying levels of refinement were constructed and tested for convergence.
- The final mesh modeled the upper half of the bimaterial specimen using rectangular eight-noded plane stress elements, with a refined region in the rubber layer itself and extending a substantial distance away from it (to a height of 5.08 mm). Element height in this region was 0.0508 mm.
- Similar results when these variables were considered: plane stress vs. plane strain elements, reduced vs. full integration, and modeling of the whole specimen rather than just the upper half.
- Boundary conditions match the experiment. Each step in the analysis represents one minute of deformation (0.254 mm of deformation applied uniformly to top surface).
- Vertical displacement constraints along plane of symmetry.
- Nonlinear geometry effects included.

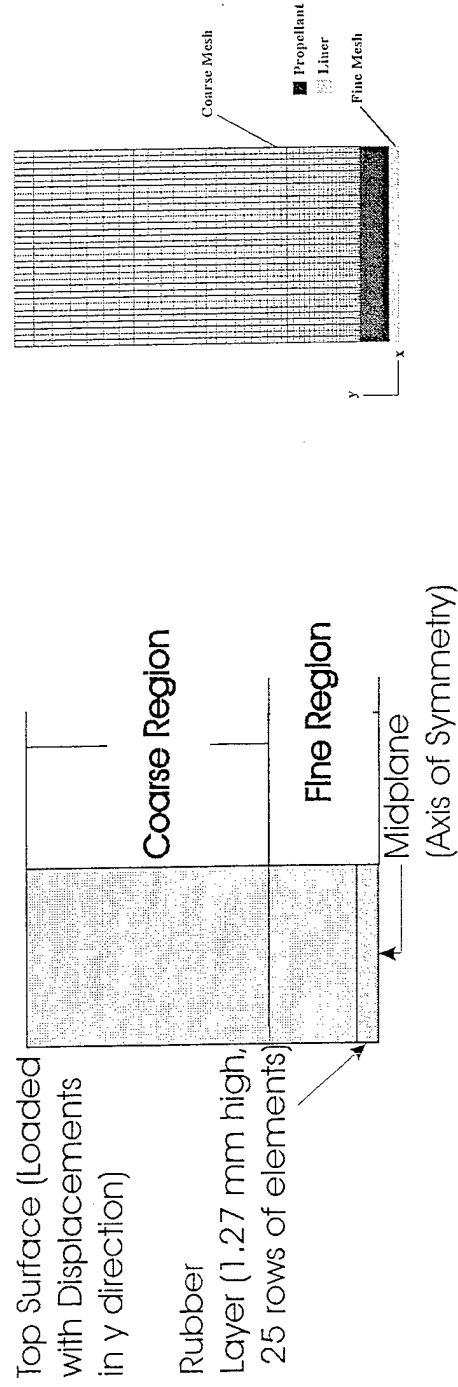

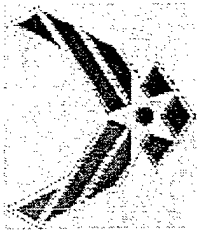

# Discussion

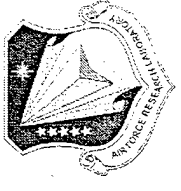

- Load vs. Displacement
- Displacement Profile
- Strain Rate Data

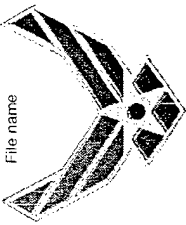

File name

# Load Versus Displacement

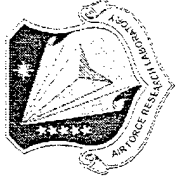

- Bimaterial specimen can be visualized as two large linear elastic springs connected by a short nonlinear spring. If the constituent properties are determined well, the overall behavior of the bimaterial experiments and the computational model should agree.
- Because most of the specimen is RPC material, this deformation dominates the overall specimen deformation. Differences in the bulk-bimaterial properties for the rubber material would affect on the overall load-displacement curve much less.

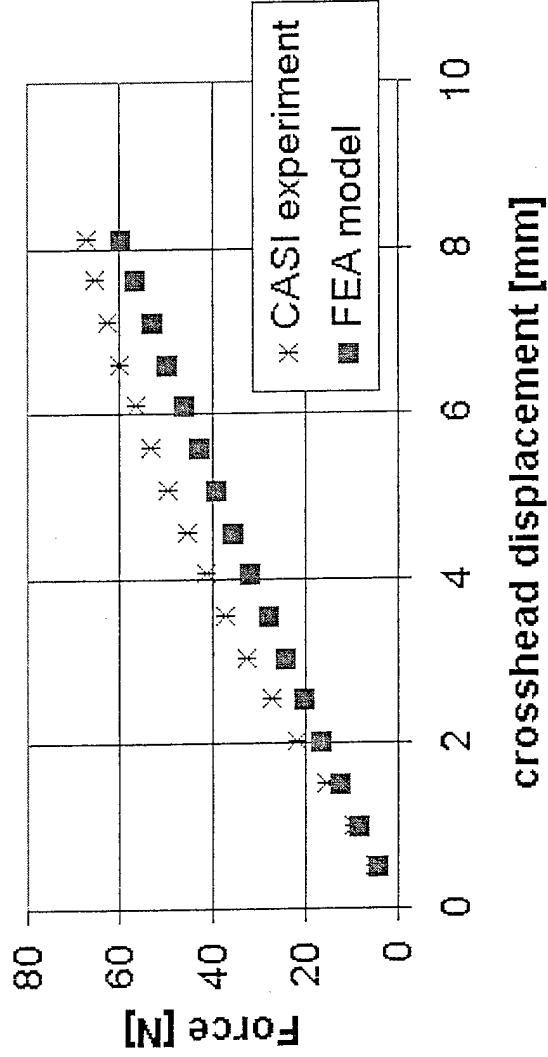

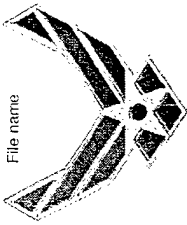

File name

# Displacement Profile



- Experimental result not shown in the computational model: the presence of five distinct regions in the bimaterial specimen. It is not known at this time what causes this.
- Further computational model refinement would probably include the use of additional constitutive properties for this region.

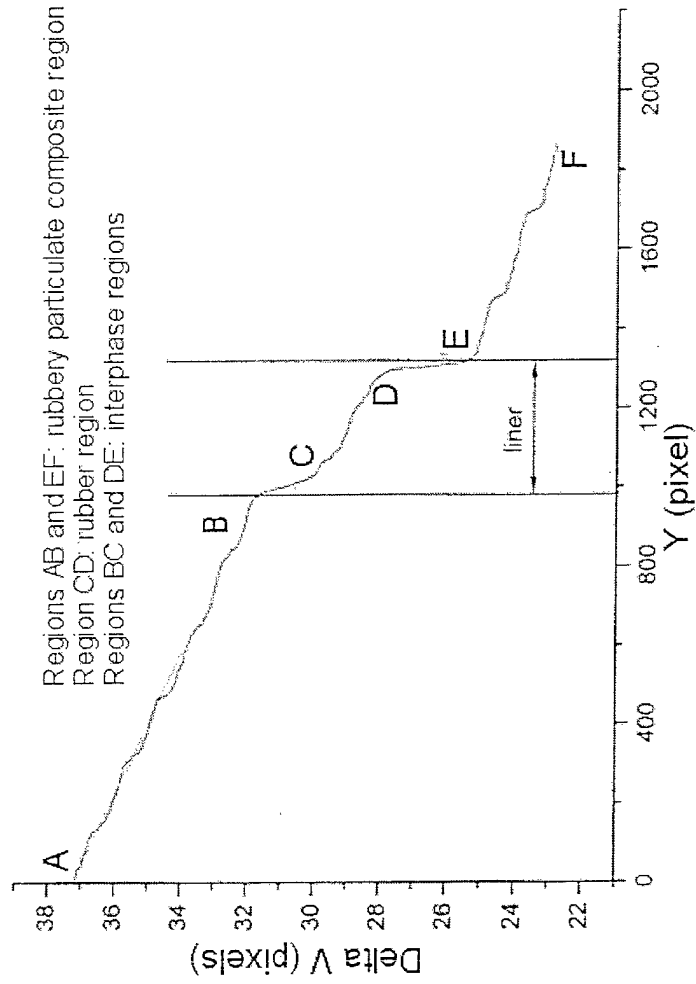

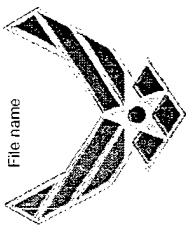

File name

# Experimental Strain Rate Determinations

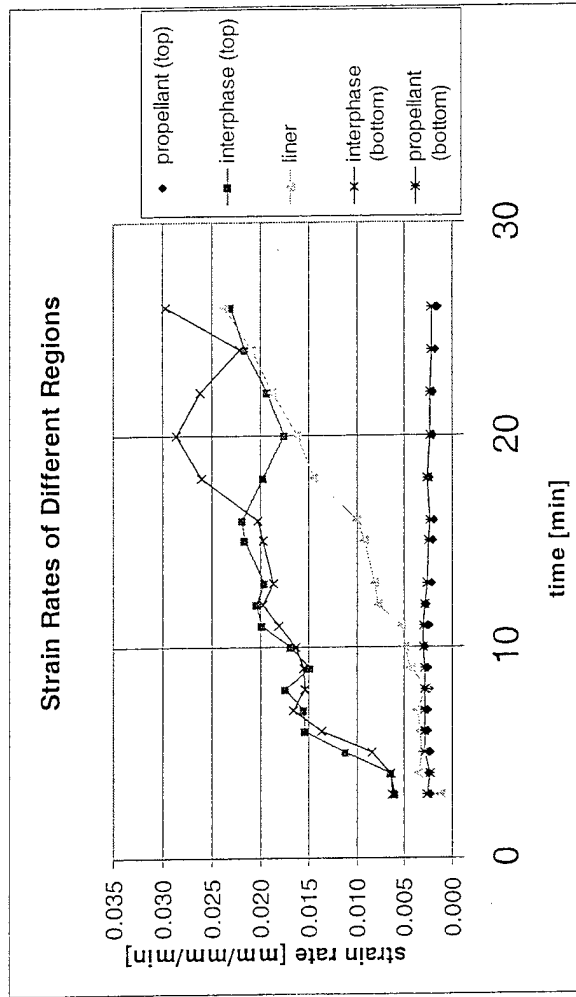

time (min)	propellant-top	top-interface	liner	interface-bottom	propellant-bottom
3	0.0024	0.0060	0.0013	0.0062	0.0026
4	0.0025	0.0064	0.0035	0.0064	0.0023
5	0.0024	0.0112	0.0031	0.0084	0.0028
6	0.0025	0.0154	0.0033	0.0137	0.0029
7	0.0026	0.0155	0.0036	0.0166	0.0029
8	0.0025	0.0175	0.0027	0.0155	0.0028
9	0.0025	0.0149	0.0044	0.0155	0.0029
10	0.0028	0.0168	0.0049	0.0163	0.0030
11	0.0024	0.0198	0.0053	0.0181	0.0030
12	0.0027	0.0204	0.0077	0.0198	0.0028
13	0.0022	0.0196	0.0081	0.0187	0.0026
15	0.0021	0.0216	0.0092	0.0198	0.0025
16	0.0019	0.0219	0.0100	0.0202	0.0023
18	0.0024	0.0197	0.0145	0.0261	0.0025
20	0.0021	0.0175	0.0163	0.0286	0.0023
22	0.0020	0.0194	0.0188	0.0262	0.0023
24	0.0018	0.0216	0.0209	0.0222	0.0021
26	0.0015	0.0231	0.0238	0.0297	0.0022

unit: 1/min

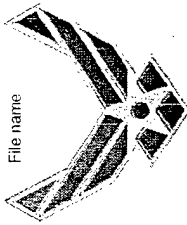

File name

# Strain Versus Time



- Figure shows strain vs. time for various regions based on image analysis (see previous slide).
- Good agreement before substantial debonding of the interface (less than 10 minutes).
- Experiments indicate increasing strain rates later in test for liner and interphase regions.
- No interphase region present in finite element model.

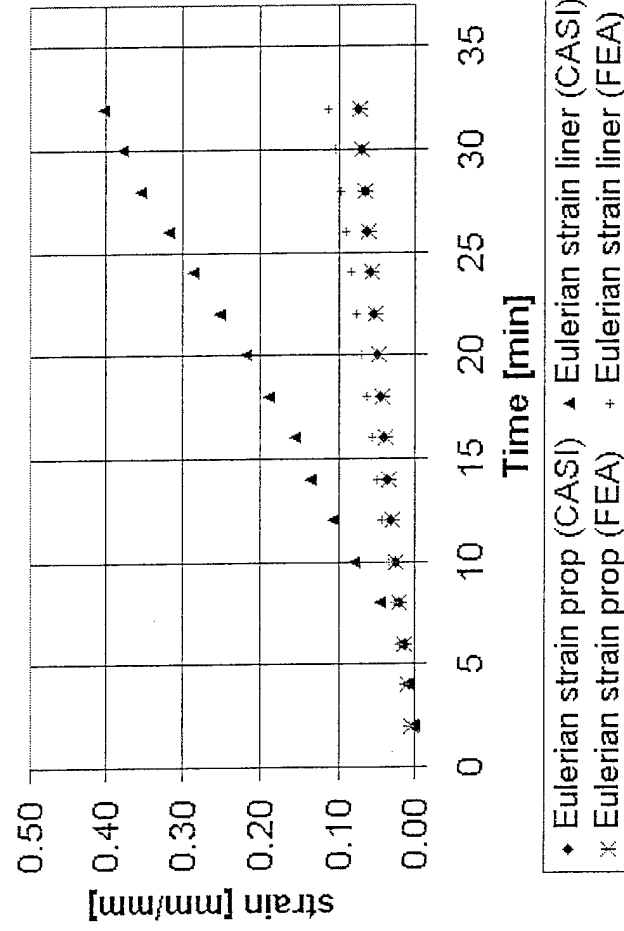

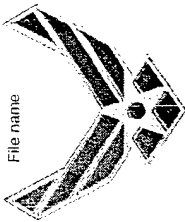

# Specimen Width Effect



- Width affected the site at which delamination of the interface occurred.
- Specimens with bigger widths (width-to-thickness ratio of 2.5 or more) delaminated near the center of the specimens.
- Specimens with width-to-thickness ratio less than 1.0 delaminated near the corner (at the intersection of the free surface and the interface).
- Bimaterial problem is a three-dimensional problem so this observation may only apply to the specimen thickness tested (5.1 mm).
- This feature of the problem has not been studied computationally.

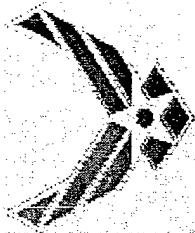

# Summary and Conclusions



- Different behavior is noticed in different regions of the bimaterial specimens. The RPC material experiences fairly uniform strain rates, but the strain rates in the rubber material increase during the specimen deformation.
- The experimental method shows that the bimaterial specimens have an interphase region that exhibits even higher strains, and that exists in a region between the rubbery particulate composite and the rubber material.
- The bimaterial specimens delaminate along the interface after about 10 minutes. The location on the interface at which this delamination occurs depends on the width-to-thickness ratio of the specimen, with more narrow specimens exhibiting edge delaminations and wider specimens exhibiting center delaminations.
- The computational model does not address the issues of the interphase region or the increasing strain rates in either the rubber layer or the interphase region.