

NAVAL POSTGRADUATE SCHOOL
Monterey, California



THESIS

**PRIME VENDOR SUPPORT (PVS) FOR THE AVENGER
M3P MACHINE GUN SYSTEM**

by

Glenn R. McPherson

December 2002

Principal Advisor:
Associate Advisor:

Michael W. Boudreau
Robert D. Overbeek

Approved for public release; distribution is unlimited

THIS PAGE INTENTIONALLY LEFT BLANK

REPORT DOCUMENTATION PAGE			Form Approved OMB No. 0704-0188
Public reporting burden for this collection of information is estimated to average 1 hour per response, including the time for reviewing instruction, searching existing data sources, gathering and maintaining the data needed, and completing and reviewing the collection of information. Send comments regarding this burden estimate or any other aspect of this collection of information, including suggestions for reducing this burden, to Washington headquarters Services, Directorate for Information Operations and Reports, 1215 Jefferson Davis Highway, Suite 1204, Arlington, VA 22202-4302, and to the Office of Management and Budget, Paperwork Reduction Project (0704-0188) Washington DC 20503.			
1. AGENCY USE ONLY (Leave blank)	2. REPORT DATE December 2002	3. REPORT TYPE AND DATES COVERED Master's Thesis	
4. TITLE AND SUBTITLE: Prime Vendor Support (PVS) for the Avenger M3P Machine Gun		5. FUNDING NUMBERS	
6. AUTHOR(S) Glenn R. McPherson		8. PERFORMING ORGANIZATION REPORT NUMBER	
7. PERFORMING ORGANIZATION NAME(S) AND ADDRESS(ES) Naval Postgraduate School Monterey, CA 93943-5000		10. SPONSORING/MONITORING AGENCY REPORT NUMBER	
9. SPONSORING /MONITORING AGENCY NAME(S) AND ADDRESS(ES) N/A		11. SUPPLEMENTARY NOTES The views expressed in this thesis are those of the author and do not reflect the official policy or position of the Department of Defense or the U.S. Government.	
12a. DISTRIBUTION / AVAILABILITY STATEMENT Approved for public release; distribution is unlimited		12b. DISTRIBUTION CODE	
13. ABSTRACT (maximum 200 words) The United States Department of Defense (DoD) is under pressure to improve the way it does business in order to save money, improve performance, and improve customer satisfaction. Numerous plans and declarations have been initiated in the past, only to be overcome by business as usual. In 1994, Secretary of Defense William Perry initiated Acquisition Reform policies, causing sweeping changes in many areas of acquisition that continue to evolve today. Reform has brought about changes in program planning, specifications, requirements, test and evaluation, systems engineering, and documentation. One area in DoD that has been a challenge for significant change is logistics. It is widely publicized that at least 60 percent of the life-cycle cost of a weapon system is in the years of sustainment after the development and production are complete. With very few new systems in development, we must find ways to improve the reliability and lower the support costs of our legacy equipment. Many pilot programs are now in place and are slowly starting to reap benefits. One program that has received recent attention is Prime Vendor Support (PVS). This thesis will examine the feasibility of Prime Vendor Support (PVS) for the M3P machine gun, a major subsystem of the Avenger air defense platform. Research will include a review of the current M3P support concept, an in-depth study of PVS and examples of where PVS is being implemented, and the advantages and disadvantages of support through PVS.			
14. SUBJECT TERMS Logistics, Prime Vendor Support (PVS), Contractor Logistics Support (CLS), Avenger, Air Defense, Small Arms, Machine Gun			15. NUMBER OF PAGES 67
			16. PRICE CODE
17. SECURITY CLASSIFICATION OF REPORT Unclassified	18. SECURITY CLASSIFICATION OF THIS PAGE Unclassified	19. SECURITY CLASSIFICATION OF ABSTRACT Unclassified	20. LIMITATION OF ABSTRACT UL

NSN 7540-01-280-5500

Standard Form 298 (Rev. 2-89)
Prescribed by ANSI Std. Z39-18

THIS PAGE INTENTIONALLY LEFT BLANK

Approved for public release; distribution is unlimited

**PRIME VENDOR SUPPORT (PVS) FOR THE AVENGER M3P .50 CALIBER
MACHINE GUN SYSTEM**

Glenn R. McPherson
DB-IV, Department of the Army
B.S.M.E.T, Southern Polytechnic College, 1981

Submitted in partial fulfillment of the
requirements for the degree of

MASTER OF SCIENCE IN PROGRAM MANAGEMENT

from the

**NAVAL POSTGRADUATE SCHOOL
December 2002**

Author: Glenn R. McPherson

Approved by: Michael W. Boudreau
Principal Advisor

Robert D. Overbeek
Associate Advisor

Douglas A. Brook, Ph.D.
Dean, Graduate School of Business and Public Policy

THIS PAGE INTENTIONALLY LEFT BLANK

ABSTRACT

The United States Department of Defense (DoD) is under pressure to improve the way it does business in order to save money, improve performance, and improve customer satisfaction. Numerous plans and declarations have been initiated in the past, only to be overcome by business as usual. In 1994, Secretary of Defense William Perry initiated Acquisition Reform policies, causing sweeping changes in many areas of acquisition that continue to evolve today. Reform has brought about changes in program planning, specifications, requirements, test and evaluation, systems engineering, and documentation. One area in DoD that has been a challenge for significant change is logistics. It is widely publicized that at least 60 percent of the life-cycle cost of a weapon system is in the years of sustainment after the development and production are complete. With very few new systems in development, we must find ways to improve the reliability and lower the support costs of our legacy equipment. Many pilot programs are now in place and are slowly starting to reap benefits. One program that has received recent attention is Prime Vendor Support (PVS). This thesis will examine the feasibility of Prime Vendor Support (PVS) for the M3P machine gun, a major subsystem of the Avenger air defense platform. Research will include a review of the current M3P support concept, an in-depth study of PVS and examples of where PVS is being implemented, and the advantages and disadvantages of support through PVS.

THIS PAGE INTENTIONALLY LEFT BLANK

TABLE OF CONTENTS

I.	INTRODUCTION.....	1
A.	PURPOSE.....	1
B.	BACKGROUND	1
C.	RESEARCH QUESTIONS	3
1.	Primary Question	3
2.	Subsidiary Questions	3
D.	SCOPE OF THESIS	3
E.	METHODOLOGY	3
F.	ORGANIZATION	4
G.	BENEFITS OF THE STUDY.....	4
II.	THE M3P, CURRENT SUPPORT CONCEPT AND ISSUES	5
A.	THE M3P.....	5
B.	THE CURRENT SUPPORT CONCEPT	6
C.	CURRENT SUPPORT ISSUES	8
D.	CHAPTER SUMMARY	9
III.	A CASE STUDY OF PVS.....	11
A.	INTRODUCTION	11
B.	WHAT IS PVS?.....	12
1.	PVS and Contractor Logistics Support (CLS)	12
2.	Performance-Based Logistics (PBL)	15
3.	Fleet Management and Reliability-Centered Maintenance (RCM)	16
4.	Virtual Prime Vendor (VPV) and Direct Vendor Delivery (DVD).....	16
5.	Partnering and Teaming	17
6.	Supply Chain Management (SCM).....	19
7.	Contractor Delivery System (CDS).....	20
8.	Reduction of Total Ownership Costs (R-TOC).....	22
C.	CHAPTER SUMMARY	23
IV.	ADVANTAGES AND DISADVANTAGES OF PVS FOR THE M3P	25
A.	INTRODUCTION	25
B.	ANALYSIS OF PVS CONCEPTS	25
1.	PVS and Contractor Logistics Support (CLS)	25
a.	Advantages.....	25
b.	Disadvantages.....	26
2.	Performance-Based Logistics (PBL)	27
a.	Advantages.....	27
b.	Disadvantages.....	28
3.	Fleet Management and Reliability-Centered Maintenance (RCM)	28

	<i>a.</i>	<i>Advantages</i>	28
	<i>b.</i>	<i>Disadvantages</i>	29
4.		Virtual Prime Vendor (VPV) and Direct Vendor Delivery (DVD)	29
	<i>a.</i>	<i>Advantages</i>	29
	<i>b.</i>	<i>Disadvantages</i>	30
5.		Partnering and Teaming	30
	<i>a.</i>	<i>Advantages</i>	30
	<i>b.</i>	<i>Disadvantages</i>	30
6.		Supply Chain Management (SCM)	30
	<i>a.</i>	<i>Advantages</i>	30
	<i>b.</i>	<i>Disadvantages</i>	31
7.		Contractor Delivery System (CDS)	31
	<i>a.</i>	<i>Advantages</i>	31
	<i>b.</i>	<i>Disadvantages</i>	31
8.		Reduction of Total Ownership Costs (R-TOC)	32
	<i>a.</i>	<i>Advantages</i>	32
	<i>b.</i>	<i>Disadvantages</i>	32
C.		CHAPTER SUMMARY	33
V.		ANSWERS TO RESEARCH QUESTIONS, CONCLUSIONS, AND RECOMMENDATIONS	35
A.		ANSWERS TO RESEARCH QUESTIONS	35
	1.	Primary Question	35
	2.	Subsidiary Questions	35
B.		CONCLUSIONS	37
	1.	Conclusion One	37
	2.	Conclusion Two	38
	3.	Conclusion Three	38
	4.	Conclusion Four	38
C.		RECOMMENDATIONS	38
	1.	Recommendation One	38
	2.	Recommendation Two	39
	3.	Recommendation Three	39
	4.	Recommendation Four	39
D.		RECOMMENDATIONS FOR FURTHER STUDY	39
		APPENDIX. EXPLODED DIAGRAM OF THE M3P	41
		LIST OF REFERENCES	51
		INITIAL DISTRIBUTION LIST	53

LIST OF FIGURES

Figure 1.	The Avenger Air Defense Weapon System.	2
Figure 2.	U.S. Army Avenger Fielded Locations.	2
Figure 3.	The Avenger M3P .50 Caliber Machine Gun System.	5
Figure 4.	Current M3P Support Structure.	7
Figure 5.	Avenger/M3P Sustainment Organization.	8
Figure 6.	DoD Life-Cycle Challenges.	12
Figure 7.	F/A-18E/F F.I.R.S.T.: How It Works.	19
Figure 8.	Sentinel CDS Development History.....	20
Figure 9.	Sentinel CDS Elements.....	21
Figure 10.	R-TOC Pilot Programs.	23

THIS PAGE INTENTIONALLY LEFT BLANK

ACKNOWLEDGMENTS

I would like to acknowledge the following management, staff, and Test Branch peers of the U.S. Army Short Range Air Defense (SHORAD) Project Office for supporting me in the pursuit of this degree, including the completion of this thesis:

- COL Robert Arnone (retired)
- COL Richard De Fatta (PM)
- Tom Hodge (DPM)
- Sandra Humphreys (Sec)
- Mike Bieri (Division Chief)
- Beverly Tierney (Sec)
- Art Allen (Test)
- Enrique Artalejo (Test)
- Mike McAlister (Test)
- Brad Volkmer (Test)

I would like to thank my advisors, Mike Boudreau (NPS) and Bob Overbeek (AMRDEC, RSA), for their insightful comments, suggestions, corrections, and guidance in the creation of this thesis. I would also like to acknowledge my children, Steven and Anna, for their patience and understanding while Dad went back to school. Lastly, a special thank you goes out to Ms. Nancy Sharrock for taking away the pain of formatting this document.

THIS PAGE INTENTIONALLY LEFT BLANK

I. INTRODUCTION

A. PURPOSE

The purpose of this thesis is to examine the feasibility of Prime Vendor Support (PVS) for the M3P machine gun, a major subsystem of the Avenger air defense platform. Research will include a review of the current M3P support concept, an in -depth study of PVS and examples of where PVS is being implemented, and the advantages and disadvantages of support through PVS. The objective of this thesis is to provide managers a background and point of departure when considering PVS in their life-cycle support strategy decisions.

B. BACKGROUND

The U.S. Army's Avenger air defense system is designed to counter aerial threats such as attack helicopters, cruise missiles, Unmanned Aerial Vehicles (UAVs), and low - level fixed-wing aircraft. The system integrates an electrically driven, gyro-stabilized, missile-firing turret on the rear of a High Mobility Multipurpose Wheeled Vehicle (HMMWV). The firing turret incorporates eight STINGER missiles (in two launch pods) with a .50 caliber machine gun (M3P) for close-in aircraft and ground attack protection. The fire control suite includes a forward-looking infrared (FLIR) sensor, laser rangefinder, heads-up optical sight and fire control computer.

Boeing's Avenger won the U.S. Army's Pedestal Mounted Stinger (PMS) Non - Developmental Item (NDI) competition and began full-scale production in 1990. Over 1000 fire units have been delivered to the Army, Army National Guard, and Marine Corps. Additional fire units have been sold via Foreign Military Sales (FMS) to Taiwan and Egypt.¹ The Avenger is currently in service at select locations in the United States and abroad as depicted in Figure 2.

¹ [<http://www.boeing.com/defense-space/space/md/avenger/>], 29 July 2002.



Figure 1. The Avenger Air Defense Weapon System.

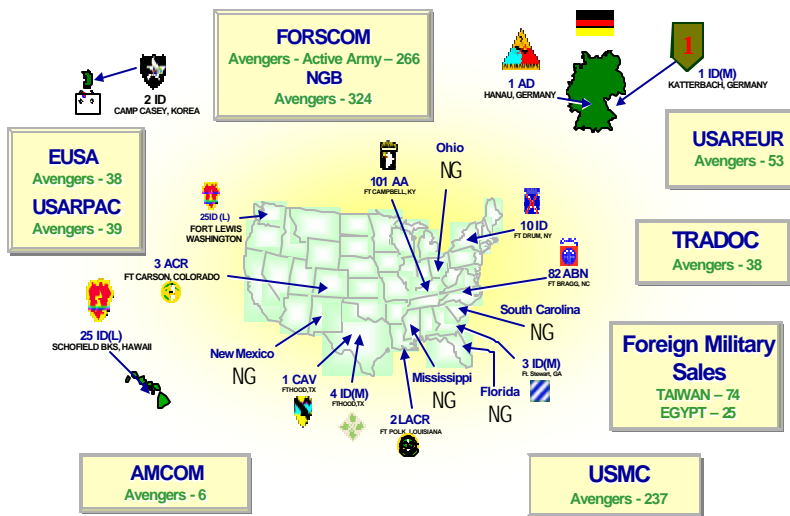

Figure 2. U.S. Army Avenger Fielded Locations.

C. RESEARCH QUESTIONS

1. Primary Question

- How might a PVS program be implemented for the U.S. Army's Avenger M3P machine gun system?

2. Subsidiary Questions

- What is the purpose of the Avenger weapon system and the M3P machine gun subsystem?
- What are the attributes of the M3P, where is it fielded, and what is the logistic support strategy?
- What is prime vendor support (PVS) and what are some examples of PVS in operation?
- What are the advantages and disadvantages of supporting the M3P through PVS?
- What conclusions and recommendations might be drawn from this case study, regarding application of PVS to weapons subsystems used by the Army or other services?

D. SCOPE OF THESIS

This thesis will be a general study of PVS and will consider the advantages and disadvantages of PVS for the M3P. The point of the study is to examine PVS programs around the DoD and “think outside the box” for the Avenger crew and repairman. The primary point of consideration is the most direct link (or links) to the source (or sources) for spare parts and technical expertise. This study will look at PVS examples, examine the advantages and disadvantages, and consider peacetime and wartime environments. This thesis will not be a detailed, Logistic Support Analysis (LSA), or attempt to provide a detailed cost study between the current support history and the proposed concept, although the savings is expected to be substantial. This thesis will be limited to support of the U.S. Army and Marine Corps M3Ps only. FMS sales of Avengers and the associated support requirements of their M3Ps will not be considered, although a direct PVS concept may be desirable.

E. METHODOLOGY

This thesis will first examine the current support concept for the M3P by interviewing key people at the Aviation and Missile Command (AMCOM), the Army Materiel Command (AMC), the Defense Logistics Agency (DLA) and users at selected

locations. The interviews will result in a summarization of the support tasks, the organizations involved, the time line, the geographical locations, and current support issues. Next, there will be a study of PVS in general and examples of PVS in both commercial and defense sectors. The analysis will continue with a comparison of the advantages and disadvantages of PVS for the M3P. Sources will include web searches, local commercial and military interviews, DoD publications, information from the NPS and other libraries, and interviews with the prime contractor. Interviews will include questions regarding spare part stocks (both on-hand and central warehousing), delivery, surge requirements, technical support (both on-site and remote), training, manuals, depot support (facilities, shipment, turn-around), special tools, and emergency/contingency operations. The PVS interview questions will be developed from the subsidiary questions in this thesis, as well as relevant questions derived from the interview discussions.

F. ORGANIZATION

- Chapter I will provide an introduction to this thesis, to include the purpose, background, research questions, scope, methodology, organization, and benefits of the study
- Chapter II will describe the attributes of the M3P, its geographical locations, and the current support concept
- Chapter III will be a case study of PVS, including examples where PVS has been implemented
- Chapter IV will describe the advantages and disadvantages of PVS for the M3P
- Chapter V will draw conclusions and recommendations of PVS application for the M3P and other weapons subsystems used by the Army or other services

G. BENEFITS OF THE STUDY

This case study could be the basis for a performance-based contract scope of work for PVS of the Avenger M3P machine gun system. The primary beneficiary of this study will be the SHORAD Project Office, should an alternate support concept be adopted. Additionally, other systems in DoD, that may have similarly unique subsystems or components, may use this study to streamline their support requirements.

II. THE M3P, CURRENT SUPPORT CONCEPT AND ISSUES

A. THE M3P

The M3P .50 caliber machine gun system is a high rate-of-fire, single barrel, recoil-operated, electrically fired machine gun based on the AN -M3 class of Browning-designed guns. The M3P is manufactured by Fabrique Nationale Herstal (FNH) in Belgium and was chosen by Boeing to meet the requirements for their PMS proposal. When the Army selected Boeing's proposal, the M3P came with it due to the nature of the NDI acquisition.



Figure 3. The Avenger M3P .50 Caliber Machine Gun System.
(ammunition box removed)

The Avenger machine gun is a system, consisting of the gun, the mounting system (an elastic, spring-loaded cradle forward and an adjustable aft mount for bore-sighting), an electric remote charger, a flexible feed chute, an ammunition box, and a catch -tray for spent ammunition cartridges and links. Additionally, there is an environmental cover to protect the gun from blowing sand, dust, and dirt. The Avenger fire-control computer has unique software to aim and fire the gun, using the gyro-stabilized turret and elevation drives, and information from the laser range finder. The Avenger M3P fires at a nominal rate of 1025 +/- 75 rounds per minute (rpm) and the basic load is normally 200 rounds of

.50 caliber ammunition. The gun system is normally fired in automatic mode, which restricts each burst to 25 rounds. The normal peacetime training routine for the M3P has been 200-400 rounds per gun, per year, with 200 rounds minimum per crew to be qualified. The Avengers were deployed during Desert Storm and in the Balkans, but no data could be found regarding the usage of the M3P.

B. THE CURRENT SUPPORT CONCEPT

Two levels of maintenance, organizational and depot, currently support the M3P. Most of the maintenance tasks are accomplished at the organizational level by the Avenger operator (MOS 14S) and the Avenger repairman (MOS 27T).² The organizational level includes regular cleaning, lubrication, and inspection by the 14S operator, as well as installing the gun, bore-sighting procedures, loading ammunition, and clearing minor jams.³ The Avenger repairman is trained to completely disassemble the gun, diagnose and replace broken parts, examine parts for noticeable wear patterns, and gage some parts for service life. The support concept includes round-dependent maintenance for many parts as a preventative measure to avoid sudden breakage and subsequent collateral damage. The crew of the Avenger records the total number of rounds fired during the life of the gun and will perform certain tasks as the rounds accumulate.⁴ The gun is required to be field stripped, cleaned and lubricated every 1250 rounds by the Avenger crew.⁵ There are certain parts (or groups of parts) that are replaced as a kit at 2500 and 5000 round intervals by the Avenger repairman. Additional parts are replaced at 10,000 rounds and the gun is nearing depot service at 30,000 rounds.⁶ If significant damage occurs, the gun is shipped to Fabrique Nationale Manufacturing Incorporated (FNMI) under a depot maintenance contract that has been extended several times over the years. The FNMI depot facility is in Columbia, South Carolina, and is a wholly owned subsidiary of FNH. This contract is for specific , depot-

² Interview with Dave Willis, PM SHORAD Logistics Team Lead for Avenger, 16 October 2002.

³ U.S. Army TM9-1425-433-10, Avenger Operator's Manual.

⁴ U.S. Army TM9-1440-433-24-1&2, Avenger Repair Manual.

⁵ U.S. Army TM9-1425-433-10, Avenger Operator's Manual.

⁶ U.S. Army TM9-1440-433-24-1&2, Avenger Repair Manual and FNH M3P Service Manual.

level support of the guns due to extreme wear or accidental damage that is beyond the capabilities of the unit-level Avenger repairman.⁷

The machine gun is supported by the traditional Army logistic support system as depicted in Figure 4.

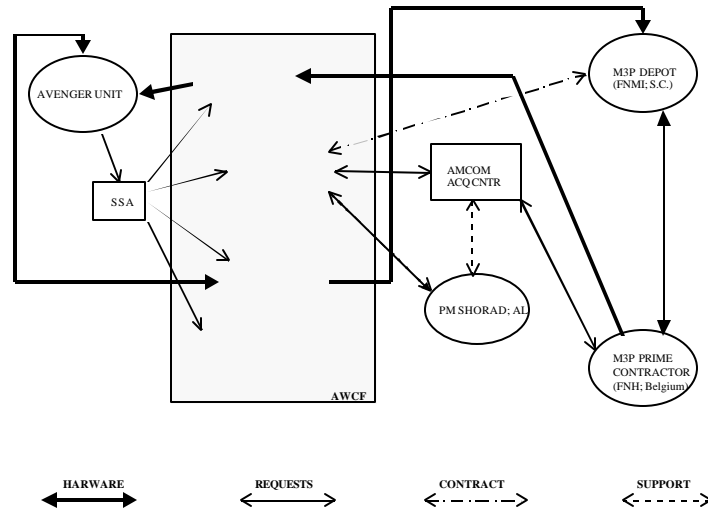

Figure 4. Current M3P Support Structure.

The unit places a requisition for M3P parts through the local Supply Support Activity (SSA), who directs the request to the appropriate command. Most of the M3P consumable parts are stocked by the Defense Logistics Agency (DLA) and are generally turned around in two to three weeks. Several parts are not stocked and must be ordered by the responsible command (AMCOM's Integrated Materials Management Center (IMMC) & Acquisition Center). As DLA stocks are depleted, automatic orders are generated to replenish the supply. The original equipment manufacturer (OEM) is the only source approved for replacement spares, except for the barrel. The OEM M3P barrel is interchangeable with the M3 barrel, of which the DoD has a large supply. Depending on the part, this ordering and delivery activity can take several months. If there has been a part number change, it often involves several letters between the IMMC,

⁷ IMMC Contract Statement of Work, Repair of Avenger and Secondary Items, 24 October 2002.

the AMCOM Acquisition Center and the OEM to clarify the nature of the change. In most every case, the change has not affected form, fit, or function, but the changing part numbers have caused confusion among the acquisition and logistics support community. Figure 5 outlines the complicated mix of organizations that are involved in the support of the Avenger and the M3P machine gun system.

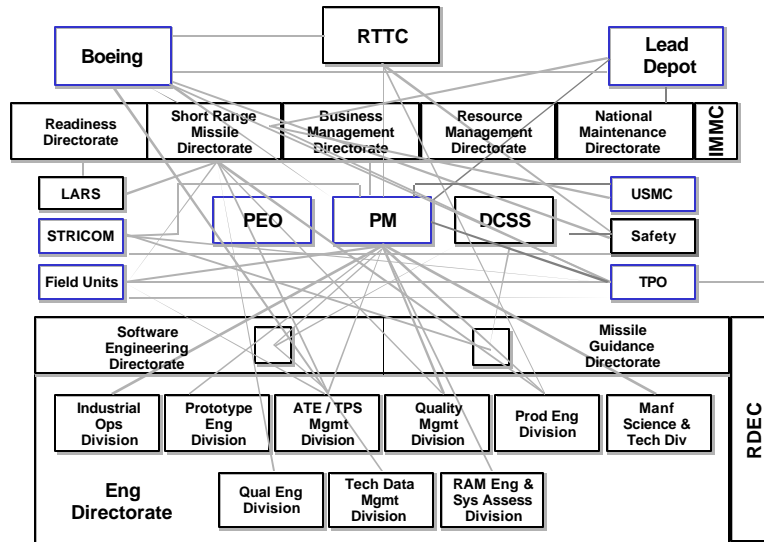

Figure 5. Avenger/M3P Sustainment Organization.

The entire machine gun system contains less than 200 individual parts (see Appendix A) that are available from the prime vendor. Most of the parts are relatively small, and are packaged and marked individually. The consumable parts, like roll pins, cotter pins and screws, are packaged in quantities equivalent to the amount found in a gun.

C. CURRENT SUPPORT ISSUES

The Avenger is the only user of this machine gun in the U.S. DoD. This presents both a problem and an opportunity. Most of the components of the M3P are unique and are not interchangeable with other .50 caliber weapons in the U.S. arsenal. In order to support the Avenger, the Army chose to fully provision the M3P, even though there are relatively few in service (less than 1000). The primary operational issues with the M3P

are supportability and readiness. The Avenger's maintenance concept and location within the division does not allow the machine gun to be serviced by qualified armorers (small arms repairmen), as with other small arms in DoD. Instead, the Avenger repairman is trained to service the gun while the Avenger crew is trained to perform additional crew-served, maintenance tasks. The maintenance tasks for the M3P are not unreasonable to learn and perform, but an armorer that is trained in small arms, is much more specialized and gets to practice his craft daily. The Avenger 27T repairman is primarily an electronics technician and gets limited, hands-on experience with the M3P, maybe twice per year. Additionally, there are very few resident machine gun "experts" at Boeing and AMCOM, and no contract currently exists for technical information and support through FNH or FNMI.

The U.S. Army does not own the Technical Data Package (TDP) to the M3P, which has been a problem over the years. Buying the TDP is cost prohibitive and just would not make good business sense, considering the small number of these weapons in service.⁸ In trying to maintain the spare parts inventory and keep the supply chain intact, AMCOM has had to devote an unusual amount of effort outside the norm.⁹ Additionally, in dealing with FNH in Belgium, there are language and time variables that can also exacerbate the problem. These problems are not insurmountable, but the resulting delays and miscommunications affect the soldier and Marine, who are the ultimate customers. More important, the soldier may lose confidence in the weapon as a result of logistics delays, which would reflect poorly on the acquisition community.

D. CHAPTER SUMMARY

The M3P machine gun is similar to other .50 caliber guns in the U.S. Army inventory, but is different enough to be in a class by itself. The gun fires almost three times as fast than any other .50 caliber machine gun and must be maintained more carefully. The gun maintenance is performed by the Avenger crew, who are not small-arms repairmen (armorers). Prior to fielding, the decision was made to not include an armorer in the air defense battalion force structure, so the Avenger crew and repairmen must perform all maintenance, except for catastrophic damage or excessive wear. In this

⁸ Interview with Ms. Kathy Torres, IMMC Lead for Avenger, 15 October 2002.

⁹ Interview with Ms. Kathy Torres, IMMC Lead for Avenger, 15 October 2002.

case, the gun is shipped to Columbia, S.C., where contractor depot technicians refurbish it. The M3P is a subsystem to the Avenger weapon system, an NDI acquisition. The U.S. Army does not own the TDP for the gun and does not have configuration control. The manufacturer has made many changes over the years, which have caused problems when trying to procure spares. In most every case, the change does not affect form, fit, or function, but the changing part numbers have caused confusion among the acquisition and logistics support community. The Army small-arms community at Rock Island Arsenal, under the Tank-automotive and Armament Command (TACOM), do not recognize the M3P and have absolved themselves of any support requirements. The M3P is the only machine gun supported by AMCOM.

III. A CASE STUDY OF PVS

A. INTRODUCTION

In 1994, Secretary of Defense William Perry initiated Acquisition Reform (now Acquisition Excellence) policies, causing sweeping changes in many areas of acquisition that continue to evolve today. Reform has brought about changes in program planning, specifications, requirements, test and evaluation, systems engineering, and documentation. One area in DoD that has been a challenge for significant change is logistics. It is widely publicized that at least 60 percent of the life-cycle cost of a weapons system is in the sustainment phase, after the development and production are complete. With very few new systems in development, we must find ways to improve the reliability and lower the support costs of our legacy equipment. In an oral statement before the House Armed Services Committee (Readiness Subcommittee) on June 27, 2000, the Honorable Jacques S. Gansler, Under Secretary of Defense for Acquisition, Technology and Logistics (USD(AT&L)), stated, "What we are trying to bring about in defense logistics has already been demonstrated in the commercial world." He continued by saying, "In defense logistics, however, such advances are more apt to move at a snail's pace, largely due to institutional resistance, outdated systems and numbing bureaucratic delays."¹⁰ Figure 6 depicts the current challenges associated with life-cycle management of defense weapon systems, according to Ms. Terry Whalen, Office of the Assistant Deputy Under Secretary of Defense for Logistics, Plans and Programs.¹¹

¹⁰ [http://www.acq.osd.mil/ousda/speech/log_hearing.html], 28 November 2002.

¹¹ Briefing, Total Life Cycle Systems Management, Ms. Terry Whalen, Office of the Asst. Dep. Under Secretary of Defense (Logistics, Plans and Programs), 10 April 2002.

- Estimated weapon systems sustainment cost of \$62B
 - Unable to link cost to performance
- Average Customer Wait Time for most items averages 18 days
 - Disconnects across the logistics functions
- Services implementing a variety of performance-based strategies
 - We need to accelerate implementation
- PMs responsible for life-cycle management
 - Limited sustainment expertise, guidance, funds
 - No formal oversight mechanism
- Requirements process that emphasizes weapon system performance
 - Limited attention to life-cycle sustainment

Figure 6. DoD Life-Cycle Challenges.

With acquisition reform, many programs are now in place and are slowly starting to reap benefits. Weapon systems managers are responsible for the overall management of the system life-cycle that includes timely acquisition that is affordable and meets the war fighter's needs, integration of sustainability/maintainability during the acquisition process, and weapon systems sustainment cost that will meet or exceed the war fighter's performance requirements.¹² One program that has received recent attention is Prime Vendor Support (PVS). The remainder of Chapter III will define PVS and examine some of the DoD programs that have, or are in the process of, implementing it.

B. WHAT IS PVS?

1. PVS and Contractor Logistics Support (CLS)

PVS could be called an offshoot of the more familiar Contractor Logistics Support (CLS). CLS has been defined as a support concept used to provide all or part of the materiel system's logistics support by contract throughout its life-cycle.¹³ CLS includes outsourcing (divesting any organic capability), partnering (sharing between

¹² Briefing, Total Life Cycle Systems Management, Ms. Terry Whalen, Office of the Asst. Dep. Under Secretary of Defense (Logistics, Plans and Programs), 10 April 2002.

¹³ CLS Implementation Best Practices Handbook, AMCOM IMMC/PEO Tactical Missiles, April 2001.

public and private sector), augmentation (planned use of public sector in times of war), and interim contractor support (planned use of public sector support while organic support is under construction). In CLS, the contractor provides maintenance, material management, and general system support according to a contract vehicle and predicted failure factors. CLS is generally contracted for specific support, but can include incentives for system performance metrics such as reliability and maintainability.¹⁴ The Avenger program used CLS through Boeing for about four years after the initial fielding began in 1990. During that time, the organic support was being structured and parts were being provisioned in order to “fill the pipeline.” Boeing acted as the depot, but also supplied parts and services as needed during the organic support build-up. The CLS contract was allowed to expire in 1995, after the Army supply system was adequately provisioned.

PVS is a more recent term, but is comparable to outsourcing under CLS. The primary difference between PVS and CLS outsourcing is that PVS is intended to involve only the prime vendor and the associated sub-contractors and vendors. CLS, on the other hand, can include open competition to any vendor that is qualified to perform the service. Under a PVS contract, the prime contractor assumes complete support responsibility for the system from the very beginning, and the contract is generally for long-term support. This includes repair, spare parts, technical support, upgrades, efficiency improvements, reliability, maintainability, and overall field performance.¹⁵ The contract is generally performance-based and typically includes incentives to drive down support costs and improve readiness and reliability by continual upgrades and modernization. A PVS approach provides single point accountability and reduced layers of support organizations. PVS builds on the best commercial practices that are in place and working daily outside of DoD.

The most publicized example of PVS has been the Army's Apache helicopter program. The Apache program accounts for 22% of the Army's Working Capital Fund (AWCF) expenditures, accounting for an estimated \$400 million per year. For Apache, the original equipment manufacturer (OEM) would assume nose-to-tail maintenance and

¹⁴ [http://www.acq-ref.navy.mil/topic.cfm?topic_id=26], 07 January 2002.

¹⁵ [http://www.acq-ref.navy.mil/topic.cfm?topic_id=23], 17 January 2002.

wholesale supply support for the entire weapons system. Under the proposed agreement, the prime vendor (Boeing) would team with the sensor-systems vendor (Lockheed-Martin) and the engine vendor (General Electric) to form a limited liability company called Team Apache Systems (TAS). TAS would operate under Army oversight and management and be responsible for all wholesale support of Apache helicopters all over the world. TAS would eliminate the need for Government personnel and facilities to support the Apache. The new organization would be responsible to acquire, manage, store and distribute spare parts and would interface directly with the soldier. The Army intended on taking advantage of commercial practices such as just-in-time-delivery and minimum inventories. TAS would be evaluated on its speed of delivery rather than its mass of inventory.¹⁶ Additionally, TAS guaranteed performance improvements to include 25% reduction in spares and repair costs, a 25% reduction in inventory investment, a 20% reduction in depot-level returns, unit-level requisition fill rates of 90% within five days for routine requests and aircraft-on-the-ground fill rates of 95% within 24-48 hours both in the United States and overseas.¹⁷ The audit firm of Price Waterhouse Coopers estimated the program cost to be \$4.8B over 20 years. The Government estimate for the same type of work over the same period was \$5.5B. The baseline estimate for current operations and support over the same 20 years was \$5.9B.¹⁸

Slightly less publicized than the Apache PVS attempt, Lockheed Martin has total PVS responsibility for the Air Force's F-117 Nighthawk aircraft. The contract was designed to eliminate duplication in support infrastructure and move some of the support tasks from the Government to private industry. The cost-plus-incentive contract provides for a 50-50 sharing of all cost reductions between the Government and the contractor. The objectives of the contracts are to see measured improvements in reliability and

¹⁶ AR Today, Vol. 4, No. 2, March-April 1999.

¹⁷ Williams, Richard L., *Apache PVS: A Case Study of Implementing the PVS Initiative World Wide in Support of the AH-64 Apache Helicopter*, Master's Thesis, Naval Postgraduate School, Monterey, California, September 2000.

¹⁸ [<http://www.afji.com/AFJI/Mags/2000/oct/milforce.html>], 10 October 2002.

system readiness.¹⁹ The F-117 support program is one of the more mature programs in operation, accounting for \$27.8 million in savings and improved aircraft performance.²⁰

2. Performance-Based Logistics (PBL)

Another support concept similar to CLS and PVS is Performance-Based Logistics (PBL). PBL is the combined support criteria that the war fighter has specified, possibly expressed as Operational Availability. PBL promotes making logistic capabilities integral to the system rather than piecemeal through all of the current logistical elements and organizations. The acquisition program would procure logistic support from a single vendor (most likely the prime vendor) and obligate the vendor by contract to performance metrics such as reliability and availability.²¹ Boeing was awarded a full development and PBL support contract for the Navy's new T-45 jet aircraft trainer and its flight simulator. The contract included the delivery of the aircraft and simulators to two sites, then all of the follow-on support. Boeing is required to guarantee the availability of a *training system* (aircraft and simulator) via a performance-based support contract.

The Air Force has established performance-based agreements with suppliers for the F-16 program, shifting total logistics sustainment to contractors for certain avionics. PBL programs are structured to measure and evaluate the contractor's performance by the end result, reliability improvements and/or a minimum acceptable availability of the system. PBL provides the contractors with longer-term contracts, allowing them to make investments to improve processes, procedures, and spare parts. The Air Force also awarded a contract to Boeing for "flexible support" of the C-17 Globemaster transport aircraft. The contract is not for certain products or services, but instead is focused on the capability of the aircraft to be mission-ready. Since the C-17 is a new aircraft, the Air Force and Boeing could start with a "clean sheet" for a support approach without the headaches of dealing with current programs, inventories, and personnel. Boeing is currently in a second, three-year PBL contract for CLS/PVS of the C-17.²²

¹⁹ Reduction of Total Ownership Costs (R-TOC), PM Magazine, January-February 2002.

²⁰ [<http://www.govexec.com/features/0900/0900s3s1.htm>], 30 July 2002.

²¹ [http://www.acq-ref.navy.mil/topic.cfm?topic_id=30], 07 January 2002.

²² [<http://www.avationnow.com/content/publication/om/200106/om71.htm>], 30 August 2002.

3. Fleet Management and Reliability-Centered Maintenance (RCM)

Fleet Management is a concept that provides support for a family of vehicles (tanks, trucks, helicopters, etc) by a competitive contract to the best-qualified contractor. Like CLS, this may or may not include the prime vendor for the particular vehicle.²³ Reliability Centered Maintenance (RCM) is the concept of developing a maintenance scheme based on the reliability of the various components of the system. Implementing a preventative maintenance program using RCM can greatly reduce the cost of ownership by focused attention on the reliability-drivers of the system. Modernization-through-spares is an element of RCM where systems are upgraded by technology insertion through the major components and Line Replaceable Units (LRUs). Using RCM and fleet management, the Army's Heavy Expanded Mobility Tactical Truck (HEMTT) is inserting new technologies to improve performance and reduce the O&S cost by replacement of high failure-rate items across the fleet. The Navy's Multi-Mission Helicopter (H-60 series) program will reduce the logistics requirements by consolidating the various makes/models of the H-60 aircraft, then employing RCM concepts to increase reliability, reduce costs and improve aircraft availability.

4. Virtual Prime Vendor (VPV) and Direct Vendor Delivery (DVD)

The older C-5 Galaxy transport aircraft is supported by a contract through the Defense Logistics Agency (DLA) as a partner in its Virtual Prime Vendor (VPV) and Direct Vendor Delivery (DVD) initiatives. The VPV contract gives responsibility for supply support of a weapon system to a single contractor. DVD allows shipping of spares directly from the vendor to the maintenance facility, without passing through a central warehouse. For the C-5, Lockheed Martin Aircraft & Logistics Center (LMALC), is responsible for managing all of the consumable parts and payment is based on cost and performance. LMALC is responsible for over a thousand suppliers as well as its own, internal production. LMALC and its host of direct vendors are required to deliver parts within eight days, anywhere in the world. The focus of the contractor is to also reduce the number of resources needed to manage the program by employing better forecasting techniques. LMALC is using Government data to populate its internal forecasting system, but with time, they will develop their own data, expecting a 20% improvement

²³ [<http://www.almc.army.mil/ALOG/issues/JanFeb99/MS383.htm>], 02 April 2002.

over the DLA system. According to LMALC, the Government data is often in complete and not up-to-date. LMALC's data system will be near real-time and more reliable. If successful, the C-5 program could be a model for other older aircraft support programs, such as the C-130 and P-3.²⁴

5. Partnering and Teaming

Partnering with industry is another variation of PVS. Government and industry have always had an obvious supplier-customer relationship. However, the partnering organizations have had separate management structures, information systems, and data, except where bound by a contract. The Navy's F/A-18E/F Integrated Readiness Support Teaming (FIRST) program retains core functions for the Navy, but expands the role of industry. The expansion is not just more contracts, but more sharing of information and integrated support roles. The contractor's role in engineering services is focused on reliability and maintainability improvements, rather than the normal role of development.²⁵ Partnering promotes the integration of Government/industry databases and information systems. The sharing of data and the integration of management controls by both organizations puts the emphasis on the quality of a product or service, and not in the interpretation of a contract. The primary driver of the FIRST program is readiness. The system is designed to improve the fleet material availability, improve reliability of the aircraft and its subsystems, and maintain a consistent pace of equipment modernization by incremental upgrades.

The Navy's FIRST program also includes a teaming arrangement between industry and the traditional Government supply-support organizations. Laws that place limits on the workload split between Government and industry govern all of the U.S. DoD depots. Congress has declared that it is essential to national security that DoD retains an organic, depot-level maintenance and repair capability in the U.S. Title 10 of the United States Code requires that Government employees must perform a minimum percentage work-share at the nation's depots. U.S. depots have been working under a Government-industry split for years, but the workload split has been creeping toward

²⁴ [<http://www.aviationnow.com/content/publication/om/200106/om71.htm>], 30 August 2002.

²⁵ Briefing, F/A 18E/F Integrated Readiness Support Teaming (FIRST), A U.S. Navy/Boeing Partnership to Improve Fleet Support and Lower Support Costs, Navy/Boeing, 02 November 2002.

more contracted-out services, within the interpretation of the law.²⁶ The FIRST program makes use of current aircraft depots and the Defense Logistics Agency (DLA), but also interjects Boeing within the scope. The Naval Air Systems Command (NAVAIR), the Naval Inventory Control Point (NAVICP), DLA, and Boeing will share the work, with NAVICP providing program oversight. Boeing will become the Inventory Control Point (ICP) for certain components, support equipment and consumables. DLA will be the ICP for F/A-18A-F common parts and multi-platform consumables. The Navy Depots (NADEPs) will continue to maintain organic repair capabilities for all platform variations, even receiving work from Boeing.²⁷ Boeing and the NADEPs (North Island, Cherry Point, and Jacksonville) have agreed to a Commercial Services Agreement (CSA) that defines the business relationship and both team members have agreed to a Task Description Document (TDD) that further defines the scope of work.

The Defense Logistics Agency (DLA) has recognized the value of partnering with industry and other Government organizations by building long-term relationships based on performance and quality. The DLA has aggressively pursued partnering arrangements to help reduce cost and turnaround time for its logistic core services, in both peacetime and war. DLA has expanded existing relationships and formed new ones, as their experience grows and they learn what is successful. Partnering with industry is an integral part of DLA's drive to improve. Such partnerships also includes elements of PVS, Vendor Managed Inventory, PBL, VPV, DVD and other demonstration projects. DLA's Defense Supply Center Columbus (DSCC) and its partner Deutsch Manufacturing found an innovative way to reduce backorders by a production line balancing technique. The effort reduced 900 backorders to 222 and prevented several potential backorders from happening. High priority backorders decreased by 20% and overall, backorders dropped by 75%. The DSCC has now expanded the effort to include nine other suppliers.²⁸

²⁶ USC, Title 10, Subtitle A, Part IV, Chapter 146, Section 2466.

²⁷ Briefing, F/A 18E/F Integrated Readiness Support Teaming (FIRST), A U.S. Navy/Boeing Partnership to Improve Fleet Support and Lower Support Costs, Navy/Boeing, 02 November 2002.

²⁸ [<http://www.dla.mil/Dimensions/Almanac/Part.htm>], 28 November 2001.

6. Supply Chain Management (SCM)

Supply Chain Management (SCM) is a commercial term and process that is being adapted more and more in the defense industry. The key ingredient in Supply Chain Management is communication. The information flow of orders, inventory, transportation, and billing for thousands of suppliers to several, worldwide locations is where the DoD is expecting to reap benefits. SCM includes the advantages of a just-in-time delivery system, but with greater visibility during the process. SCM is becoming an industry within industry, as independent companies are formed to provide this service to other companies. Although many companies adopt SCM internally, many are opting to contract out this supply support service.²⁹ The Navy's FIRST program is centered on the process of SCM and the associated integrated information systems. Figure 7 depicts the flow of information through the principle organizations of the FIRST program.

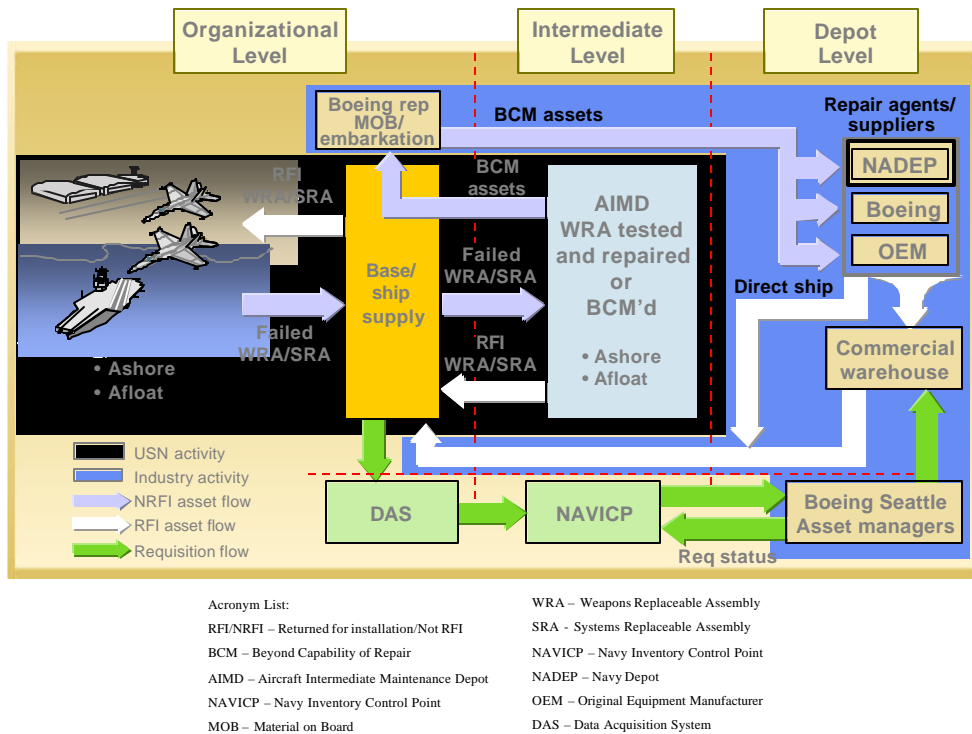

Figure 7. F/A-18E/F F.I.R.S.T.: How It Works.

²⁹ Briefing, F/A 18E/F Integrated Readiness Support Teaming (FIRST), A U.S. Navy/Boeing Partnership to Improve Fleet Support and Lower Support Costs, Navy/Boeing, 02 November 2002.

SCM supports the partnership between Government and industry by the sharing of data and resources, rather than duplication. SCM supports the reduction in total ownership costs by providing accurate and timely data to the decision-makers, suppliers and customers.

7. Contractor Delivery System (CDS)

The Army's Short Range Air Defense (SHORAD) Project Office recently awarded (October 2002) a contract to Raytheon for a PVS-like program called the Sentinel Contractor Delivery System (CDS). The Sentinel is the Army's ground-based, mobile air defense radar that provides a local air picture and target cueing to the SHORAD air defense commander and the associated fire units (Avenger, Linebacker, & the Man Portable Air Defense System (MANPADS)). The Sentinel CDS is the result of a life-cycle support study initiated in 1998. Figure 8 depicts the historical path of the CDS program.

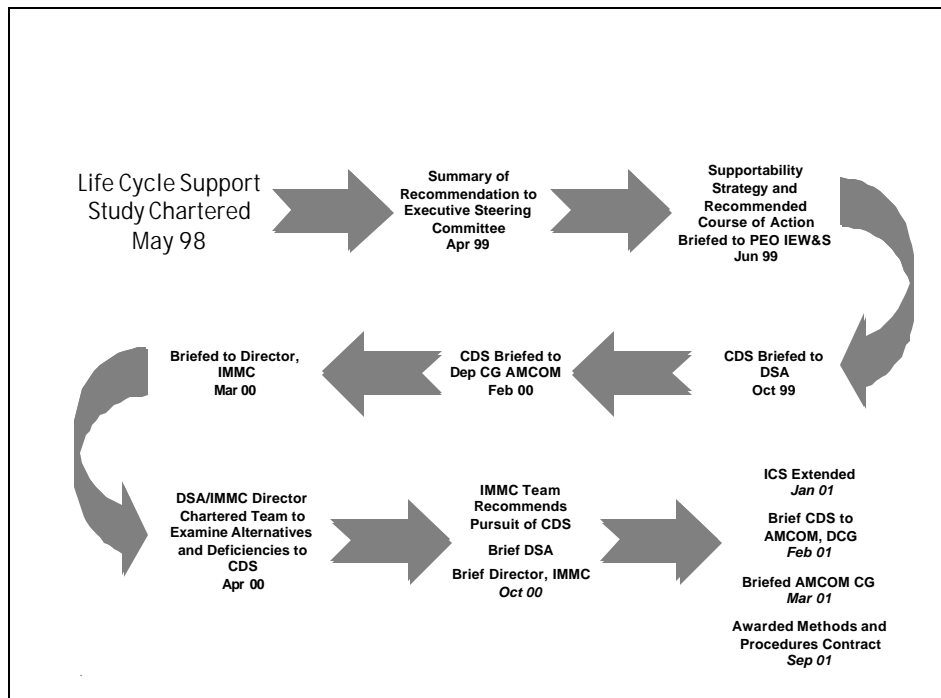

Figure 8. Sentinel CDS Development History.

The Sentinel CDS program is the result of an Integrated Product Team Process that evaluated five alternatives before selecting the CDS and Government Depot Partner concept. Figure 9 depicts the elements of the CDS program.

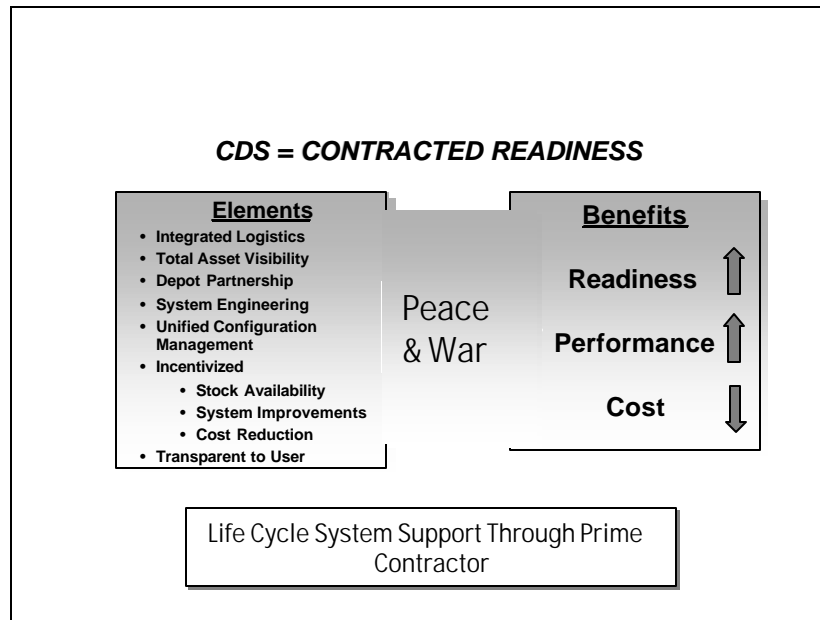

Figure 9. Sentinel CDS Elements.

The Sentinel CDS is designed to provide the Army a minimum readiness rate of 90% for both the fleet average and the unit-level readiness rate. The program will not have any Authorized Stockage List (ASL) spares and only 32 Prescribed Load List (PLL) spares to start. The contractor will be free to adjust PLL spares in order to optimize the readiness rate to meet or exceed the contracted readiness requirement. Under the contract, the user will receive repair parts for free, but documentation will still pass through the SSA. The contractor will provide a 24/7 Help Line and a Contact Team on request. The contractor is incentivized to improve readiness through redesign of high failure rate items (RCM), improved processes (PBL), and reduced administration burdens (PBL & SCM).

The Sentinel CDS IPPT did not want to impose this program without future assessments and possible reevaluation. The program is designed to first complete a

ninety-day Limited User Implementation (LUI) using CDS to support one Army Division. This will verify the validity of materiel issue without inclusion of a Defense Finance and Accounting System (DFAS) transaction, verify the unique parts catalog, verify the 24/7 Help Line and responsiveness, and verify the process for the Contact Teams, if needed. After implementation, there will be a follow-on assessment after two years, then additional assessments as required.³⁰ The contract for this service is with the PM rather than through the IMMC. The PM is now directly responsible for life-cycle support of the Sentinel radar and will control the contract and the funding. The Sentinel CDS program is one initiative that currently has the greatest control of life cycle funding by a PM to a single contractor.³¹ The initial contract award was in October 2002, so this will be a program to watch.

8. Reduction of Total Ownership Costs (R-TOC)

In 1999, Dr. Gansler established a process called the Reduction in Total Ownership Cost (R-TOC). This effort was started due to the concern for the rising cost of logistics and the simultaneous depletion of funds for modernization. Although R-TOC attacks the ownership cost issue from many fronts, a core element is PVS. R-TOC has remained intact through the most recent administration change and includes many projects from the three major services. In order to be considered an R-TOC pilot activity, the programs were required to focus on three areas for potential savings:

- Reliability and maintainability improvements (RM)
- Reduced supply chain delivery times (SC)
- Competitive sourcing of product support (PS)

All of these areas have benefits associated with PVS. For R-TOC, each service has ten weapon system projects listed as pilot programs (Figure 10). Per instruction from the USD(AT&L), each of the programs must focus their efforts on one, two, or all three of the above listed areas. Sixteen out of the thirty programs include all three areas in their savings approach (four for the Army, five for the Navy/Marine Corps, and seven for the Air Force). All of the sixteen include activities such as PVS, PBL, reliability-centered maintenance, performance-based support contracts, partnering with industry,

³⁰ Sentinel CDS Site Activation Briefing, LTC David Cook, Sentinel Product Manager, May 2002.

³¹ Briefing, Total Life Cycle Systems Management, Ms. Terry Whalen, 10 April 2002.

and CLS.³² The R-TOC programs are required to participate in Pilot Program Forums, which allow a free exchange of ideas across the various programs so that all may benefit from the experience of the other programs. The R-TOC forum consolidates the progress and performance of many initiatives across the DoD and will be a valuable source of lessons-learned, contracting incentives, measurement tools, legislative/regulatory barriers, and cost savings estimates.

<u>Army Pilots</u>	<u>Navy/Marine Pilots</u>	<u>Air Force Pilots</u>
Abrams Tank	Advanced Assault Amphibious Vehicle (AAAV)	Air Warning and Control System (AWACS)
Apache Helicopter	Aegis Cruiser	B-1B Long-Range Bomber Aircraft
CH-47 Chinook Helicopter	Aviation Support Equipment (ASE)	C-5 Cargo-Troop Transport Aircraft
Crusader	CVN-68 Nimitz Class Carrier	C-17 Cargo Aircraft
Fire Support C2	Common Ship	C/KC-135 Stratotanker Aircraft
Guardrail Common Sensor System (GCSS)	EA-6B Prowler Aircraft	Cheyenne Mountain (NORAD Combat Operations Center)
Heavy Expanded Mobility Tactical Truck (HEMTT)	H-60 Multi-Mission Helicopter	F-16 Tactical Aircraft
High Mobility Artillery Rocket System (HIMARS)	LPD-17 Class Carrier	F-117 Stealth Fighter Aircraft
Integrated Target Acquisition System (ITAS)	Medium Tactical Vehicle Replacement (MTVR)	Joint Surveillance Target Attack Radar (JSTARS)
	Standoff Land Attack Missile-Expanded Response (SLAM-ER)	Space-Based Infrared Systems (SBIRS)

Figure 10. R-TOC Pilot Programs.

C. CHAPTER SUMMARY

PVS is a term that has become synonymous with contracting out to prime vendors, lock, stock, and barrel. This chapter has shown that PVS is more than a single-faceted approach and that there are several features of PVS that are present in other logistics cost-saving programs. CLS, PBL, CDS, DVD, VPV, Partnering, RCM, SCM, and others have collectively encouraged integrated systems and communication, faster turnaround times for orders, reduced inventories, just-in-time deliveries, single point of contact, lower overhead costs, long-term contracts, work-sharing, performance-based

³² Reduction of Total Ownership Costs (R-TOC), PM Magazine, January-February 2002.

contracts and programs, reliability improvements, and modernization through spares. There is no “one size fits all” approach to improving DoD logistics. There are certain core tasks that cannot be contracted out due to current laws and/or unique expertise. The Army, Navy, Marine Corp, and Air Force are all participating in PVS -like programs. Acquisition reform has allowed PMs to explore alternative ways of doing business and many have been successful. The DoD has initiated the R-TOC pilot programs as a way to give visibility to many of these logistics improvement programs, but also to consolidate initiatives to gain lessons-learned. Newer programs such as the C-17, F/A-18E/F, and Sentinel may have the latitude to start with a clean slate for their logistic programs and experiment with alternate support concepts. Established programs like the C-5 and the Avenger have to look for ways to adapt these cost-savings programs within the existing, legacy support structure. The following chapter will outline the advantages and disadvantages of the various programs studied in this chapter, and recommend a PVS approach that may benefit the M3P machine gun system.

IV. ADVANTAGES AND DISADVANTAGES OF PVS FOR THE M3P

A. INTRODUCTION

By implementing PVS concepts, the DoD has the potential to reduce the cost of ownership (personnel, facilities, and inventory) and, at the same time, build an effective support network within the Defense Industrial Base. With PVS, the prime contractor provides much of the hardware and manpower, but also executes the appropriate contracts with subcontractors, Original Equipment Manufacturers (OEMs), system integrators and other specialty vendors.³³ PVS has the potential to provide a simplified management structure, a single point of accountability, reduced spares acquisition time and reduced inventory levels.³⁴ Using performance and incentive-based contracting, PVS promises to also improve the reliability of weapon systems by effective spares management and continuous upgrades to stay ahead of obsolescence issues. Additionally, the M3P is currently supported by two levels of maintenance, which means that PVS could be applied at the depot level without negative impact at the unit level. In total, PVS could result in a significant reduction in Operation and Support (O&S) costs, an increase in readiness, and systems that are more modern and capable.³⁵ This chapter will examine the PVS concepts from the previous chapter and analyze their advantages and disadvantages, as they apply to the M3P.

B. ANALYSIS OF PVS CONCEPTS

1. PVS and Contractor Logistics Support (CLS)

a. Advantages

An important advantage of PVS for the M3P is a single point of contact for any issues with support of the machine gun system. The unit can currently contact the depot (LEAD), Boeing, the IMMC, and the PM, but none can guarantee complete expertise on the system. The unit may try to contact small-arms repairmen within the division, but the M3P is unique and its support structure is not the same service as that of

³³ [http://www.acq-ref.navy.mil/topic.cfm?topic_id=23], 17 January 2002.

³⁴ Article: Prime Vendor Support - The Wave of the Future. [<http://www.almc.mil/ALOG/issues/JanFeb99/MS383.htm>], 02 April 2002.

³⁵ Article: AR Today, Volume 4, No. 2, March/April 1999, "Apache Prime Vendor Support".

other .50 caliber weapons. Under PVS, FNH/FNMI would be the “go to” contact for technical, operational, and logistics information. When an M3P machine gun system issue occurs in the field, there would be one place to call for support. The PVS/CLS contract could be structured to allow a contact team (if needed) to visit the location and provide emergency service support anywhere in the world. PVS could allow the unit to interface directly with the prime vendor when ordering spare parts for the gun system, reducing the chance of ordering the wrong parts. Additionally, direct interface would allow the unit to choose the method of shipment, depending on the circumstances and urgency of the order. Average wait time for parts could be 2-3 days rather than the current estimate of 18 days. PVS could also allow for technology insertions as a part of supply support, helping to keep the system current and improving reliability by employing RCM techniques. Lastly, ordering spare parts direct from the vendor would reduce the cost of the parts by eliminating AWCF overhead charges, which could be as much as 40%.

The primary argument for PVS centers on increased efficiency and some level of anticipated savings. For Apache, the Army had negotiated a 17 percent reduction in cost per flying hour through the period of performance of the firm fixed-price contract. This also included over \$325 million in modernization through spares, which was expected to contribute to the 17 percent reduction.³⁶ The Price Waterhouse Coopers estimate of savings for Apache PVS was \$1B over 20 years. The Government's estimate of PVS-like changes to Apache operations and support was about \$.7B over the same 20-year period. For the M3P, a baseline cost of doing business the current way would have to be established and used for comparison with a PVS/CLS program.

b. Disadvantages

An important concern of PVS/CLS is the obligation of contractors on the battlefield in times of war. Corporations have generally continued to service contracts in times of war, but will they be able to keep quality, knowledgeable people in the forward area, to include support from their subcontractors? As more contractors are added to logistics support, there will be a need to provide for their protection on the battlefield. Uniformed logistics specialists are also trained as soldiers and can supplement the

³⁶ AR Today, Vol. 4, No. 2, March-April 1999.

fighting force as required. Contract personnel are non-combatants and must be assured some level of protection by the military. This could lead to personnel increases in the battle area, negating some of the benefit of PVS. Today's threat of asymmetrical warfare only complicates the issue when it comes to protecting non-combatants. In the past, rear areas were thought to be relatively safe, but with chemical, biological, and nuclear threats, the boundaries of the battle area become blurred.³⁷

A primary reason for the failure of the Apache PVS was its effect on the Army Working Capital Fund (AWCF). The loss of the Apache spares revenue within the fund would virtually "bankrupt" the system unless the PVS contractor bought them from the Army at the "retail" price. The Apache parts represent an inventory valued between \$200 and \$500 million and the annual expenditure has been about \$400M, which affects the AWCF surcharge. Additionally, other Army officials, who were opposed to the PVS concept, contested the cost savings estimates, stating that estimates for emergencies and other "over and above" costs were not considered³⁸. Although the M3P spares at DLA aren't anywhere near this amount (estimated to be worth about \$2M³⁹), there would be an associated cost to extract those spares from the AWCF and hand them to a PVS contractor.

The implementation of PVS in general would displace Government workers to some degree. Much of the work being done at DLA, the depots and other support organizations would transfer to a PVS contract, depending on the contract scope. For the M3P, there are very few (if any) Government employees that are tied directly to the M3P, and only the M3P. For other programs, this might not be the case. Although it is a concern, it is not a major disadvantage for a PVS concept for the M3P.

2. Performance-Based Logistics (PBL)

a. Advantages

Each Avenger comes with a single M3P machine gun system. There are no spare guns (floats), so each gun contributes directly to the readiness of the Avenger.

³⁷ Article: Contractors on the Battlefield: Risks on the Road Ahead?, <http://www.almc.mil/ALOG/issues/JanFeb99/MS376.htm>, 03 June 2002.

³⁸ <http://www.afji.com/AFJI/Mags/2000/oct/milforce.html>; 10 October 2002.

³⁹ Interview via Email with Ms. Kathy Torres (IMMC-Maintenance) and Mr. Leon Stanley (IMMC-Item Manager), 05 November 2002.

Although the M3P does not have a direct reliability requirement, tests by the PM measured the Mean-Rounds-Between-Stoppage of the M3P to be in excess of 4000 rounds. This, of course, was with proper maintenance and the appropriate replacement parts. By implementing PBL, the contractor's support performance could be measured by the readiness of the Avenger, with particular regard to the M3P machine gun system. Although the exact performance metrics are not known at this time, the standard for the entire weapon system could be allocated to each of the primary components, including the M3P. Once the baseline is determined for the M3P, the PVS contractor could be incentivized to improve the reliability by material changes, additional training, or some other method. Increasing the reliability of the M3P would improve the readiness of the Avenger and instill confidence in the Avenger crew.

b. Disadvantages

PBL would be very difficult to implement for the M3P because it would be difficult to obtain realistic performance data on the guns. Although the M3P was tested and evaluated for reliability, there is not an established reliability standard or requirement. Availability of the machine gun is not a requirement associated with small arms. A gun is either available or it's not. Currently, Operational Availability of the Avenger is reported at the system level, but it is calculated based on the missile system and fire control components and does not include the M3P.

3. Fleet Management and Reliability -Centered Maintenance (RCM)

a. Advantages

Fleet Management is not directly applicable to the M3P. However, many of the PVS contracts examined contain RCM or incentives for modernization-through-spares. The contractor could be incentivized to insert system upgrades to keep the system up-to-date and to preclude obsolescence issues as the weapon system matures. RCM would track the reliability drivers of the system and implement material improvements that could improve the system reliability/maintainability and increase the service life. The M3P is based on a design from the 1920's, but is able to perform reliably at the elevated rate-of-fire because of the updated design and the advances in metallurgy. The M3P would continue to be an inexpensive, increasingly effective weapon as materials and manufacturing techniques improve and with future advances in ammunition, such as

the Sabot Light Armor Penetrator (SLAP) .50 caliber (12.7 mm) round, which could add range and penetration power to the M3P.

b. Disadvantages

RCM for the M3P will add cost by the Government to review each change proposal and modernization of components will involve some level of testing to confirm reliability and safety prior to fielding a change.

4. Virtual Prime Vendor (VPV) and Direct Vendor Delivery (DVD)

a. Advantages

VPV and DVD could allow the unit to interface directly with the prime vendor when ordering spare parts for the M3P gun system. Currently, ordering through the supply system does not require a working knowledge of the M3P by the supply clerks or item managers. Their expertise is in the part number, National Stock Number (NSN), nomenclature, and the “system” in which this information resides. Using VPV, an Avenger repairman would call the prime vendor and would connect to a knowledgeable technician manning a help desk, who possibly would be able to resolve the issue over the phone. If a part should need to be ordered, the repairman would more likely get the right part shipped at the right time, reducing the chance for the need to reorder. Like the commercial world, the unit could choose to have the parts shipped via normal common carriers (U.S. Postal Service, UPS, DHL, etc.), or overnight in an emergency. In a war environment, the unit would deploy with a pre-determined supply of spares for each gun in the battalion and replenishment spares would be shipped into the theater as needed by military transport.

The current inventory levels for the M3P at DLA are for “just-in-case” (an estimated 10,000 parts⁴⁰) rather than optimized for the demand (an estimated 500 requisitions per month⁴¹). PVS contracts are generally incentivized for the contractor to reduce cost and overhead and still meet or exceed the minimum readiness. PVS could allow the contractor to maintain the absolute minimum inventory levels and build his own database for determining what the level should be.

⁴⁰ Interview via Email with Ms. Kathy Torres (IMMC-Maintenance) and Mr. Leon Stanley (IMMC-Item Manager), 05 November 2002.

⁴¹ Interview via Email with Ms. Kathy Torres (IMMC-Maintenance) and Mr. Leon Stanley (IMMC-Item Manager), 05 November 2002.

b. Disadvantages

VPV does not apply to the M3P because very little service is performed at a central location, such as the depot. There are no disadvantages to DVD for the M3P, except for the possibility of displaced Government workers, which has been previously addressed in this chapter.

5. Partnering and Teaming

a. Advantages

Partnering or Teaming with industry for PVS (or some variant of PVS) would allow the defense industry to stay in the business. The U.S. defense budget has been in a net decline for over a decade and many defense-related companies have sold out to larger concerns, divested themselves of the defense business, or closed their doors altogether. The life-cycle support of current and future weapon systems could be enough to help keep small and medium-sized companies in business. FNH (through FNMI) is one of the largest suppliers of small arms to the U.S. DoD, but is small compared to many defense conglomerates. As defense budgets ebb and flow and new orders prove unreliable, the company could change the focus of its business from production to life-cycle support, allowing it to stay in the Defense Industrial Base. In the future, if there should be need for a small to medium arms production capability, FNMI would be in position to ramp up for production again very quickly.

b. Disadvantages

There are no disadvantages to Partnering/Teaming for the M3P as long as the relationship is clearly outlined and established to promote communication and information sharing. In support of other systems, discussions could well become mired in the pros and cons of Government support versus contractor support. In the case of the M3P, the arguments are framed in contractor support versus no support at all.

6. Supply Chain Management (SCM)

a. Advantages

Supply Chain Management could improve the communication between the operating units and the source for M3P parts and expertise. An SCM system could provide an information source for orders, inventory, transportation status, and billing for the M3P customers and would be relatively easy to implement because of the small

number of parts in inventory. An SCM system would allow Government organizations, the vendor, and the customer to access the same database of information regarding the M3P. SCM could include a just-in-time delivery system that could minimize the in-process inventory at FNH/FNMI, reducing overhead costs and improving material flow in their production process. A website for technical briefs, lessons -learned, “how to” information, recent part changes, system alerts, and a catalog ordering system could benefit the user and provide a common access point for all.

b. Disadvantages

Implementing an SCM system could possibly require a change in the normal operating procedures at the unit level, or at least changes to legacy software. Different forms, computer programs, and procedures may be perceived as a nuisance in the day-to-day operations of the Avenger repairman. Additionally, there is an up-front cost associated with implementing a SCM system and some level of yearly sustainment.

7. Contractor Delivery System (CDS)

a. Advantages

CDS could provide the same benefits discussed earlier in this chapter for CLS/PVS. CDS is a successful model for planning a PVS -like concept. The PM, the contractor and the user participated in an IPT process to design a system that could be mutually beneficial, efficient, and affordable. The implementation of CDS for Sentinel includes a trial period and a reassessment before full implementation. Another assessment is planned after two years to see if the program is working as planned or may need some adjustment. The Sentinel CDS system has recently been implemented (October 2002) and should be watched as model for other programs, to include the M3P. The M3P is managed out of the same PM office as Sentinel, so there should be real-time lessons -learned and experience available to the M3P program.

b. Disadvantages

The disadvantages of CDS for the M3P are the same as those discussed for PVS/CLS earlier in this chapter.

8. Reduction of Total Ownership Costs (R-TOC)

a. Advantages

The implementation of PVS for the M3P can benefit from the R-TOC pilot programs that are either in place or soon to be implemented. The R-TOC programs have projected a combined estimated fiscal savings in 2005 for the Army (12%), the Navy (18%) and the Air Force (10%)⁴². These projected savings are averages and should not be used to project the “goodness” of each service program. The goal of the R-TOC program is to achieve a 20% savings in life-cycle support costs. If the services are able to come close to these savings, other programs will more likely follow. The R-TOC programs could be a valuable source for lessons-learned and best practices that may apply to the M3P.

b. Disadvantages

The R-TOC Pilot Programs have already recognized that O&S funding restrictions are a distinct disadvantage. O&S support funding is one-year money, meaning it must be obligated yearly and there is no guarantee that the same level of funding will be available in subsequent years. PVS/CLS initiatives rely on long-term contracts and partnerships that guarantee a level of work the contractor can rely on. Annual budget issues such as limits on appropriations categories, reprogramming restrictions, and Continuing Resolution Authority (CRA) make PVS contracting an incomplete solution if funded by O&S alone.

R-TOC programs have also determined that tools and processes are inadequate to measure PVS savings and perform the trade-off analyses needed to make the strategic decisions. This only complicates the estimating and projections needed to implement and maintain a PVS-like contract on a yearly basis.

R-TOC programs have also discovered that if true savings are realized, there are no guarantees that the program can apply those savings to another area of their program. R-TOC savings are likely to cause a reduction in O&S funding across the services in the future, rather than be available for the program that earned it. Unless the anticipated savings of an M3P PVS contract can be applied to another area of Avenger (such as the modernization of another component), the PM has no incentive to put forth

⁴² Reduction of Total Ownership Costs (R-TOC), PM Magazine, January-February 2002.

the effort and change the process. The last major disadvantage is the PM's lack of control of the program's life-cycle support funding.⁴³ With no significant source of seed money for a new -start PVS program and limited control of long-term sustainment funds, there is little incentive for PMs to “rock the boat” and attempt to change the course.

C. CHAPTER SUMMARY

The M3P is a relatively obscure component on an established weapons platform that could be used to implement an alternative program, experiment with the process, measure the performance and either proclaim victory or quietly go back to the old way of doing business. Small size is a distinct advantage for change, rather than attacking a huge program like the Apache, with all of the established logistics stakeholders.

The virtues of PVS have yet to be proven over a period of time (including peacetime and wartime) and contractors have not had to deal with such a large area of logistics responsibility in the past. The DoD and defense contractors have always been notorious for over -estimating the savings projections and/or under-estimating the cost of other programs. How can we expect estimates for PVS concepts to be any different? Some projected the Apache PVS 20-year savings to be substantial while others argued that the estimates were “critically flawed” and “not defensible.” The Apache PVS program cost was difficult to estimate because it was so huge, complex, and controversial.

There are many advantages and disadvantages to PVS concepts in general, but the application of PVS must be tailored for the specific needs of the program. The research for this thesis shows there are many variations of PVS, and each has associated advantages and disadvantages, depending on the application. The idea of contractor support and contracting out are not new, but partnering with industry and sharing information between the public and private sector are new to the DoD. For the M3P, there is currently no working relationship (engineering services) with the prime vendor (FNH/FNMI). The advantages listed above would be welcomed by the end-user of the system, and that is where the effect should be measured. The Avenger crew -member would simply see more timely parts availability and more accurate information when needed. The cost-savings to the Army and improved readiness are the by-products from

⁴³ Reduction of Total Ownership Costs (R-TOC), PM Magazine, January-February 2002.

satisfying the support needs of the end-user (customer), but are difficult to accurately predict and effectively measure.

There are many disadvantages to PVS as a general strategy, but most (as with the advantages) are dependent on the application. For the M3P, contractors would not be needed on the battlefield to support the M3P. PVS for the M3P would be well suited as a preventative maintenance measure, which is where most of the effort is, except for rare occasions when Avengers might be deployed in a battle area for a long period. In this case, PVS could be applied to the rear areas, perhaps as the Avengers are off-loaded in theater, or as they return from the battle area for other service needs. As with any O&S support, PVS would be subject to the funding restrictions of O&S funding, impacting the contract support during normal budget fluctuations and funding trade-offs between other higher-priority programs.

The next chapter will draw conclusions and make recommendations about PVS for the M3P, and suggest topics for further study of this subject.

V. ANSWERS TO RESEARCH QUESTIONS, CONCLUSIONS, AND RECOMMENDATIONS

A. ANSWERS TO RESEARCH QUESTIONS

1. Primary Question

- How might a PVS program be implemented for the U.S. Army's Avenger M3P machine gun system?

A PVS program could be implemented for the M3P by a partnership with FNH/FNMI, using the IPT process to outline and structure a mutually beneficial arrangement, prior to entering into any contract negotiations. After the scope is defined, cost estimates could be made for a PVS program and funding could be identified. A PVS/CLS concept would work best for the M3P, since the prime vendor is the only source of support for the M3P. Using lessons -learned and best practices from the R-TOC programs and Sentinel CDS, an M3P PVS concept would have a starting advantage over support programs tried elsewhere.

2. Subsidiary Questions

- What is the purpose of the Avenger weapon system and the M3P machine gun subsystem?

The U.S. Army's Avenger air defense system is designed to counter aerial threats such as attack helicopters, cruise missiles, Unmanned Aerial Vehicles (UAVs), and low - level fixed-wing aircraft. The firing turret incorporates eight STINGER missiles (in two launch pods) with a .50 caliber machine gun (M3P) for close-in aircraft and ground attack protection.

- What are the attributes of the M3P, where is it fielded, and what is the logistic support strategy?

The M3P .50 caliber machine gun system is a high rate-of-fire, single barrel, recoil-operated, electrically fired machine gun based on the AN-M3 class of Browning-designed guns. The Avenger is fielded at fourteen CONUS locations, Hawaii, Germany, and Korea (see Figure 2). Two levels of maintenance, organizational and depot, currently support the M3P. Most of the maintenance tasks are accomplished at the organizational level by the Avenger crewman (MOS 14S) and the Avenger repairman (MOS 27T). Spare parts are requisitioned through the Army Supply Support Activity (SSA) and

warehoused at DLA. LEAD provides depot support for the Avenger, but ships the M3P to FNMI for depot service.

- What is prime vendor support (PVS) and what are some examples of PVS in operation?

PVS is a concept where the prime contractor of a weapon system assumes complete support responsibility for the system from the very beginning, and the contract is generally for long-term support. This includes repair, spare parts, technical support, upgrades, efficiency improvements, reliability, maintainability, and overall field performance. Examples of PVS in operation can be found within the RTOC Pilot Programs sponsored by the DoD and discussed in Chapters III and IV of this thesis.

- What are the advantages and disadvantages of supporting the M3P through PVS?

This thesis has shown that PVS could be an advantage for the M3P by increasing readiness and improving the performance of the machine gun system, and potentially reducing the life-cycle support cost. The Avenger's M3P machine gun is an ideal candidate for a PVS-like program because it is a clearly separate component on the Avenger and different from any other .50 caliber machine gun system in the U.S. DoD. The M3P is also clearly differentiated within the current logistic system and can be isolated for study. The primary disadvantages to PVS are the issue of contractors on the battlefield, the effect of PVS on the Working Capital Fund (WCF) and the displacement of Government employees.

- What conclusions and recommendations might be drawn from this case study, regarding application of PVS to weapons subsystems used by the Army or other services?

This thesis has shown that PVS could increase readiness and improve the performance of the M3P, and potentially reduce the life-cycle support cost. PVS must only be applied where it makes sense to do so, and after careful consideration of the requirements for peacetime and deployment for war. PVS contractors should be established DoD suppliers and have adequate quality systems, storage and warehousing for parts, and the core personnel (managerial, administrative, and technical) to administer a PVS support contract. PVS for large, established programs like the Apache proved to be “too much, too soon.” For the legacy systems, smaller programs or possibly

subsystems to larger programs could be considered as candidates for a PVS-like support concept. The recommendations listed in this thesis could apply to any program considering a PVS support concept.

B. CONCLUSIONS

This thesis has shown that PVS could increase readiness and improve the performance of the M3P. Although there is limited data, PVS concepts have also contributed to life-cycle cost savings (the F-117 program claims \$27.8M in savings and the Army, Navy, and Air Force R-TOC programs are forecasting 12%, 18%, and 10% reductions, respectively, starting in 2005). PVS must only be applied where it makes sense to do so, and after careful consideration of the requirements for peacetime and deployment for war. PVS contractors are generally established DoD suppliers and have adequate quality systems, storage and warehousing for parts, and the core personnel (managerial, administrative, and technical) to administer a PVS support contract. If the contractor is serious about customer satisfaction and wants to get into the life-cycle support business, then a PVS contract for the M3P will be more likely to be successful. The following conclusions have been reached by this thesis research:

1. Conclusion One

The Avenger's M3P machine gun is an good candidate for a PVS -like program because it is a clearly separate component on the Avenger, and different from any other .50 caliber machine gun system in the U.S. DoD. The M3P is also clearly differentiated within the current logistic system and can be isolated for study. The M3P machine gun system is currently almost entirely supported at the organizational level and will not likely be negatively affected by a PVS implementation. On the contrary, support at the retail level could be enhanced by a PVS help desk arrangement. Depot maintenance (where the bulk PVS would be applied) is for only the most extreme damage or extended wear from the cumulative effects of firing. M3P guns in need of depot-level maintenance currently are sent to LEAD, who forwards them to FNMI via an IMMC-FNMI contract. The Avenger crew currently receives little or no technical information from LEAD for M3P issues and LEAD does not serve as a conduit to FNMI for direct support information. This leads to the conclusion that the Avenger systems would receive depot-

level support more directly under a PVS contract and the crewmen and repairmen would have improved access to the source of technical information.

2. Conclusion Two

A PVS support concept for the M3P should include the direct ordering of spare parts from the prime contractor. The current supply system provides less-than-desirable service and speed of delivery in support of the M3P. The inventory of spare parts at DLA appears to be too large for the number of M3Ps in service. Over time, a PVS contract would drive that excess inventory down to a minimum, reducing cost and space. The M3P machine gun system contains less than 200 individual parts, making it a very manageable project for a PVS support concept.

3. Conclusion Three

A PVS contract could improve the training and deployment readiness of the M3P by having access to the prime contractor's knowledge and expertise. The Avenger units train once or twice each year, culminating in a combined live-fire for both the missile system and the machine gun. The successful firing of the M3P on the training range (gun fires at the specified rate with no stoppages) would better prepare the Avenger crew for the battle area.

4. Conclusion Four

It is the conclusion of this thesis that a PVS concept should be investigated, implemented, and evaluated for the Avenger M3P machine gun system. PVS implementation could improve the performance of the machine gun system, reduce the cost, reduce the spare parts inventory, and improve the soldier's and the Marine's confidence in the M3P.

C. RECOMMENDATIONS

The following recommendations are suggested to begin implementation of a PVS program for the Avenger M3P machine gun. These recommendations also apply to any other program considering PVS for all or part of their program.

1. Recommendation One

Establish baseline costs and performance metrics of the current M3P support system. If a new support system is to be implemented, there needs to be a method for predicting the savings and evaluating the results. The PM should establish an IPT to

measure the support performance in the areas that will be affected by a PVS contract. The metrics must be quantifiable, easily measured, and not easily subject to manipulation.

2. Recommendation Two

Contact the R-TOC Pilot Program representatives for more information, suggestions, lessons -learned, and best practices that may apply to the M3P. Attend the open pilot program forums and establish a relationship with programs that may have a similar PVS structure.

3. Recommendation Three

Initiate an IPT with the user and FNH/FNMI to discuss a PVS contract. The IPT should be tasked to outline a structure that includes technical support, spare parts, shipping, manuals, a website, contact teams, training, battle area support, depot support, warehousing, and contract administration. The focus of the IPT is to identify the scope of the support, taking into account the requirements of the contractor and the customer. After a common understanding of the scope, the contractor should be able to estimate the cost for a PVS contract.

4. Recommendation Four

Design a small-scale pilot program to test a PVS contract for the M3P. Select one or two units that would agree to be a test case, then implement and measure the results. Data and feedback from the user and the contractor could be used to adjust the program before a worldwide implementation.

D. RECOMMENDATIONS FOR FURTHER STUDY

- Follow-up study on the progress of the R-TOC Pilot Programs and the development of a combined lessons -learned document. These initiatives have been established to reduce the pilot program's total ownership costs and will be a valuable resource for programs considering a PVS support concept.
- An in-depth study of tools that are available for the measurement of logistics performance. The study should focus on measurement tools that are deficient or non-existent, and make recommendations for the development of special measurement and assessment tools.
- A study of the funding issues associated with long-term O&S contracts. The R-TOC programs have identified funding regulations and regulatory restrictions of O&S support contracts as a universal concern.

THIS PAGE INTENTIONALLY LEFT BLANK

APPENDIX. EXPLODED DIAGRAM OF THE M3P

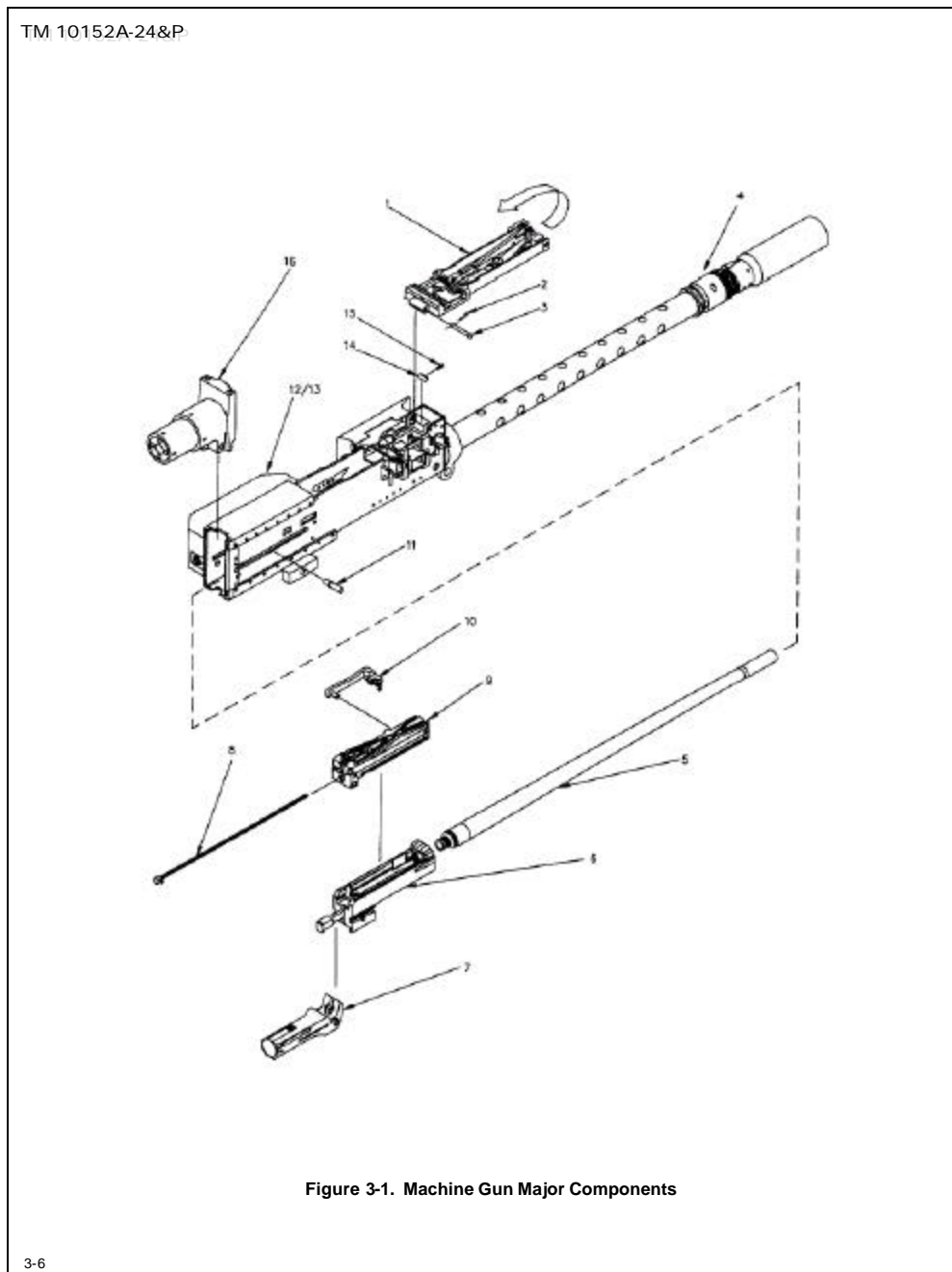

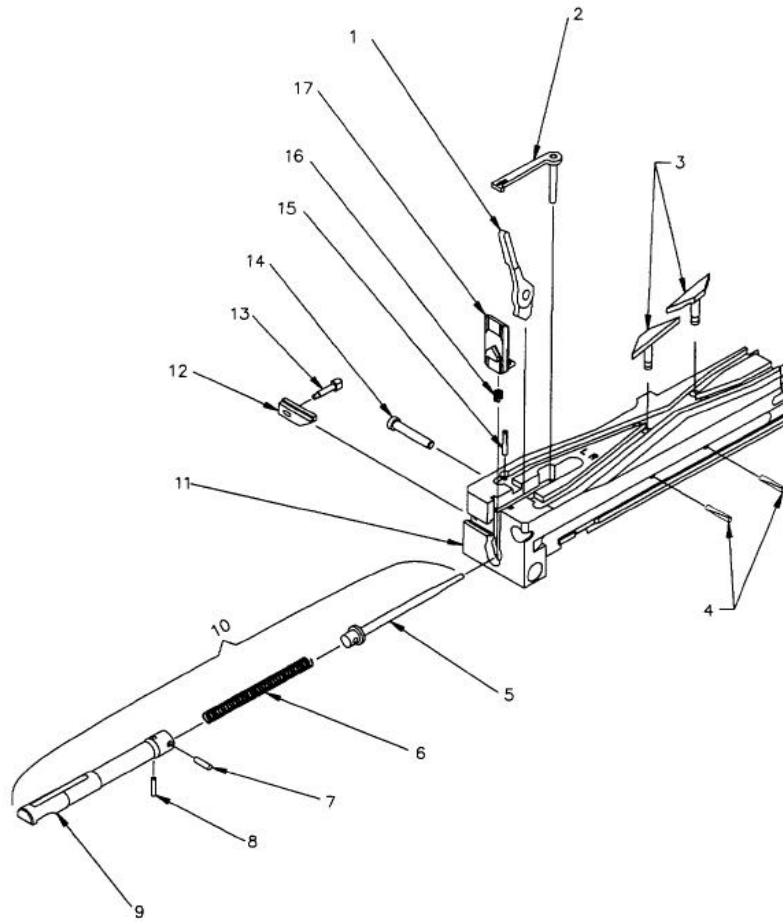

Figure 3-2. Bolt Assembly

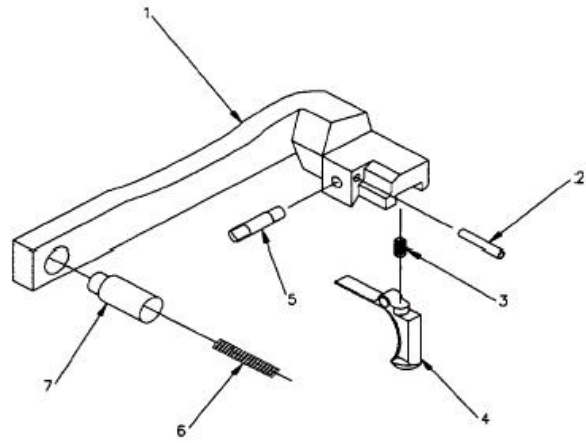

Figure 3-3. Extractor Assembly

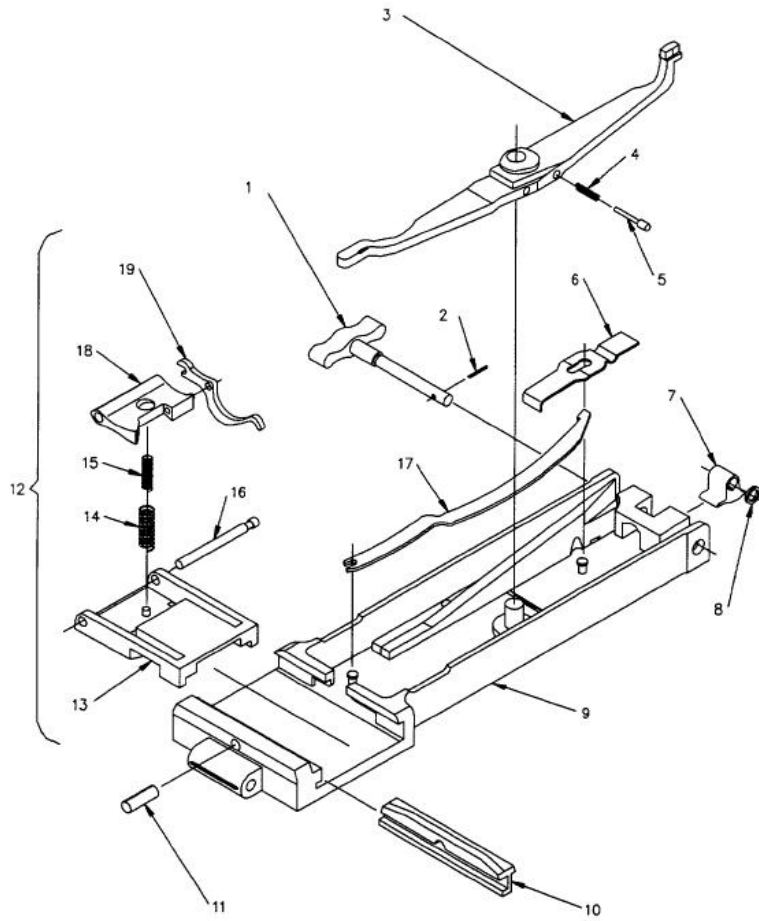

Figure 3-4. Feed Cover Assembly

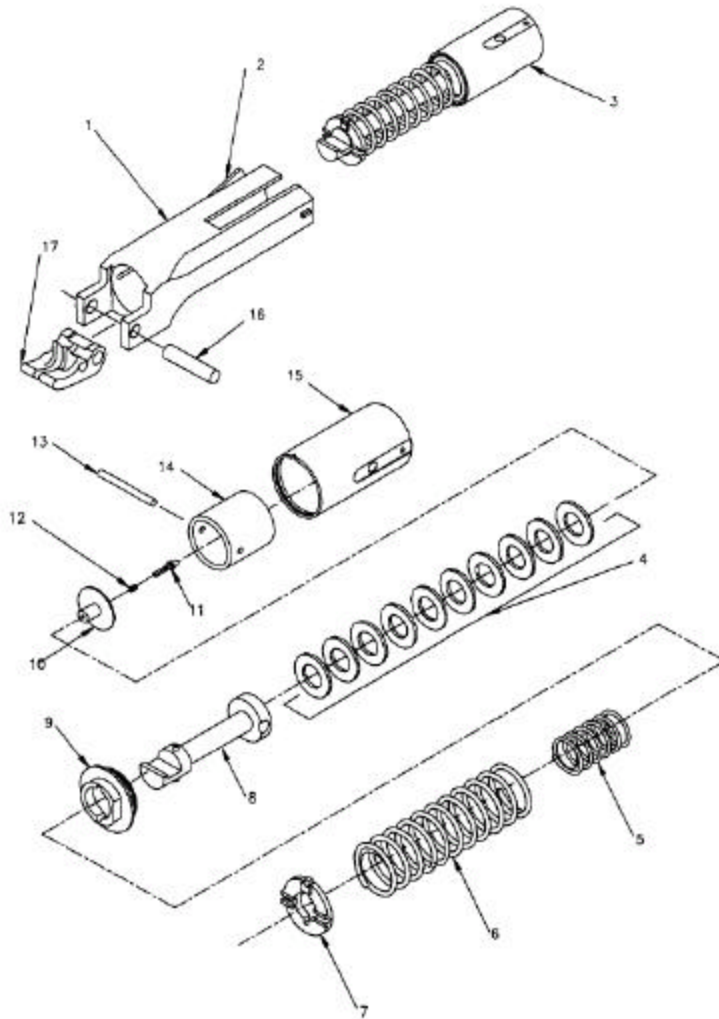

Figure 3-6. Barrel Buffer Assembly

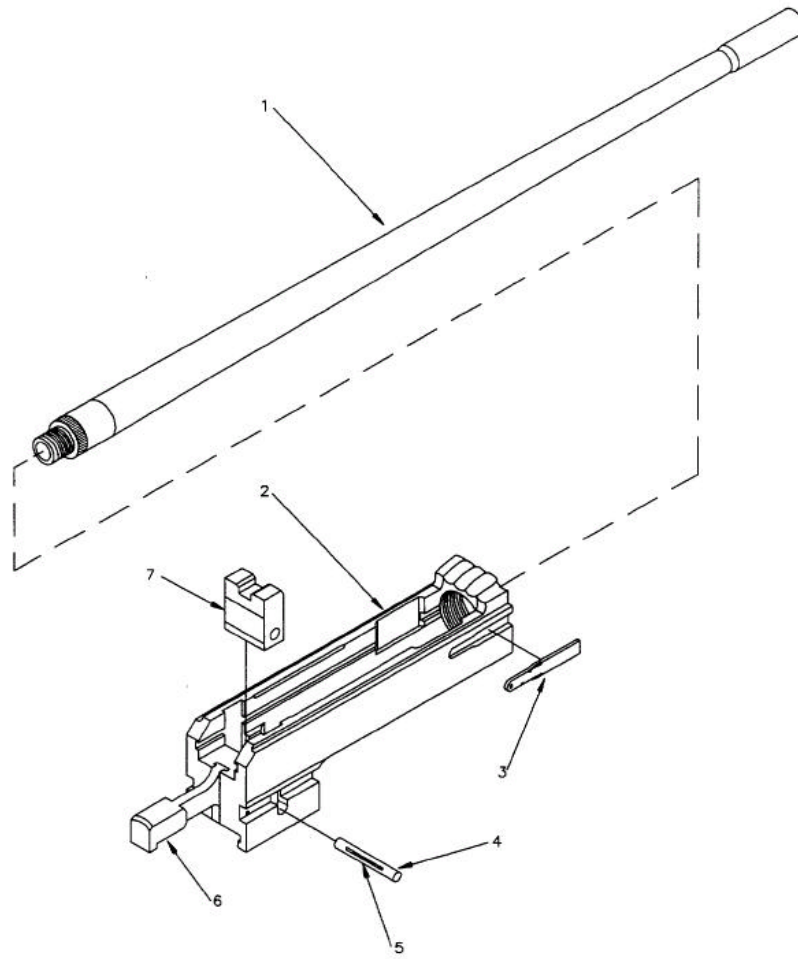

Figure 3-7. Barrel and Barrel Extension Assembly

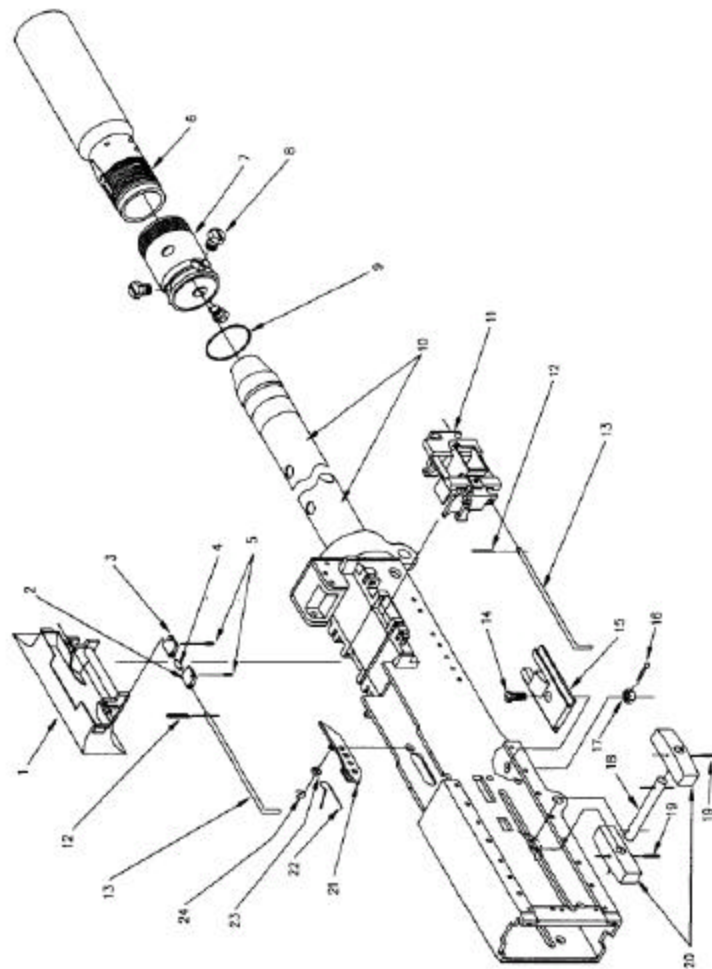

Figure 3-8. Receiver Assembly

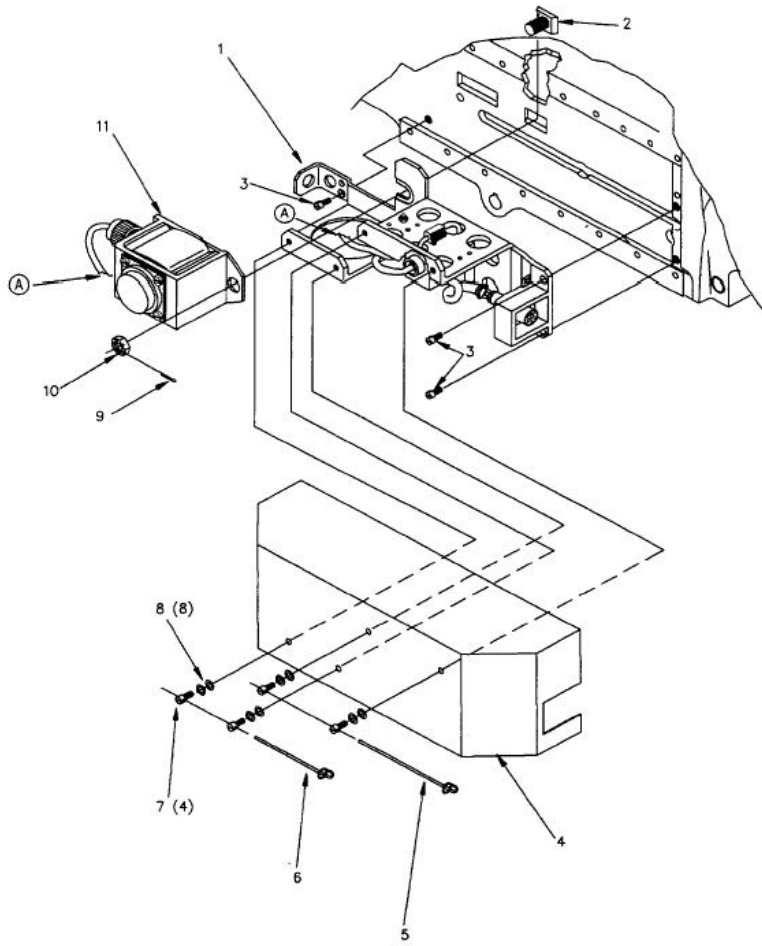

Figure 3-9. Solenoid and Sensor Assembly

THIS PAGE INTENTIONALLY LEFT BLANK

LIST OF REFERENCES

- AR Today, Vol. 4, No. 2, March-April 1999, 29 July 2002.
- Article, Apache Prime Vendor Support, AR Today, Vol. 4, No. 2, March/April 1999.
- Article, Reduction of Total Ownership Costs (R-TOC), PM Magazine, January-February 2002.
- Article: Contractors on the Battlefield: Risks on the Road Ahead?, [<http://www.almc.mil/ALOG/issues/JanFeb99/MS376.htm>], 3 June 2002.
- Article: Prime Vendor Support - The Wave of the Future, [<http://www.almc.mil/ALOG/issues/JanFeb99/MS383.htm>], 2 April 2002.
- Blanchard, Benjamin S., Logistics Engineering and Management, Prentice-Hall Inc., Fourth Edition, 1992.
- Briefing, F/A 18E/F Integrated Readiness Support Teaming (FIRST), A U.S. Navy/Boeing Partnership to Improve Fleet Support and Lower Support Costs, Navy/Boeing, March 2001.
- Briefing, Total Life Cycle Systems Management, Ms. Terry Whalen, Office of the Asst. Dep., Under Secretary of Defense (Logistics, Plans and Programs); 10 April 2002.
- CLS Implementation Best Practices Handbook, AMCOM IMMC/PEO Tactical Missiles, April 2001.
- FNH M3P Service Manual, No. 3648910023, January 1996.
- [<http://acqnet.salt.army.mil/acqref/ArmyContracting99/page6.htm>], 02 April 2002.
- [http://acq-ref.navy.mil/topic.cfm?topic_id=31], 07 January 2001.
- [<http://ness.external.lmco.com/ss/lifesupp/scpvs.htm>], 02 April 2002.
- [http://www.acq.osd.mil/ousda/speech/log_hearing.html], 28 November 2002.
- [http://www.acq-ref.navy.mil/topic.cfm?topic_id=23], 17 January 2002.
- [http://www.acq-ref.navy.mil/topic.cfm?topic_id=23], 17 January 2002.
- [http://www.acq-ref.navy.mil/topic.cfm?topic_id=30], 07 January 2002.
- [<http://www.acq-ref.navy.mil/topic.cfm?topic-id=26>], 07 January 2002.
- [<http://www.afji.com/AFJI/Mags/2000/oct/milforce.html>], 10 October 2002.

[<http://www.almc.army.mil/ALOG/issues/JanFeb99/MS383.htm>] 02 April 2002.

[<http://www.avationnow.com/content/publication/om/200106/om71.htm>], 30 August 2002.

[<http://www.boeing.com/defense-space/space/md/avenger/>], 29 July 2002.

[<http://www.dla.mil/Dimensions/Almanac/Part.htm>], 28 November 2001.

[<http://www.dla.mil/Dimensions/Almanac/Part.htm>], 28 November 2001.

[<http://www.govexec.com/features/0502/0502managetech.htm>], 30 July 2002.

[<http://www.govexec.com/features/0900/0900s3s1.htm>], 30 July 2002.

IMMC Contract Statement of Work, Repair of Avenger and Secondary Items, 24 October 2002.

Interview via Email with Ms. Kathy Torres (IMMC-Maintenance) and Mr. Leon Stanley (IMMC-Item Manager), 05 November 2002.

Interview with Dave Willis, PM SHORAD Logistics Team Lead for Avenger, 16 October 2002.

Reduction of Total Ownership Costs (R-TOC), PM Magazine, January February 2002.

Sentinel CDS Site Activation Briefing, LTC David Cook, Sentinel Product Manager, SHORAD PMO, May 2002.

U.S. Army TM9-1425-433-10, Avenger Operator's Manual.

U.S. Army TM9-1440-433-24-1&2, Avenger Repair Manual.

USC, Title 10, Subtitle A, Part IV, Chapter 146, Section 2466.

Williams, Richard L., *Apache PVS: A Case Study of Implementing the PVS Initiative World Wide in Support of the AH-64 Apache Helicopter*, Master's Thesis, Naval Postgraduate School, Monterey, California, September 2000.

INITIAL DISTRIBUTION LIST

1. Defense Technical Information Center
Ft. Belvoir, Virginia
2. Dudley Knox Library
Naval Postgraduate School
Monterey, California
3. Glenn R. McPherson
Huntsville, Alabama
4. Robert D. Overbeek
Redstone Arsenal, Alabama
5. Michael W. Boudreau
Naval Postgraduate School
Monterey, California
6. Michael A. Bieri
PM SHORAD
Redstone Arsenal, Alabama
7. Gail Alsbrooks
PM SHORAD
Redstone Arsenal, Alabama