

NAVAL POSTGRADUATE SCHOOL Monterey, California



THESIS

**ASSESSING THE RISK OF INADVERTENT NUCLEAR
WAR BETWEEN INDIA AND PAKISTAN**

by

Stephen A. Smith

December 2002

Thesis Advisor:
Second Reader:

Peter R. Lavoy
Surinder Rana

Approved for public release, distribution is unlimited

THIS PAGE INTENTIONALLY LEFT BLANK

REPORT DOCUMENTATION PAGE			Form Approved OMB No. 0704-0188	
Public reporting burden for this collection of information is estimated to average 1 hour per response, including the time for reviewing instruction, searching existing data sources, gathering and maintaining the data needed, and completing and reviewing the collection of information. Send comments regarding this burden estimate or any other aspect of this collection of information, including suggestions for reducing this burden, to Washington headquarters Services, Directorate for Information Operations and Reports, 1215 Jefferson Davis Highway, Suite 1204, Arlington, VA 22202-4302, and to the Office of Management and Budget, Paperwork Reduction Project (0704-0188) Washington DC 20503.				
1. AGENCY USE ONLY (Leave blank)		2. REPORT DATE December 2002	3. REPORT TYPE AND DATES COVERED Master's Thesis	
4. TITLE AND SUBTITLE: Assessing the Risk of Inadvertent Nuclear War Between India and Pakistan			5. FUNDING NUMBERS	
6. AUTHOR(S) Stephen A. Smith, MAJ, USA				
7. PERFORMING ORGANIZATION NAME(S) AND ADDRESS(ES) Naval Postgraduate School Monterey, CA 93943-5000			8. PERFORMING ORGANIZATION REPORT NUMBER	
9. SPONSORING /MONITORING AGENCY NAME(S) AND ADDRESS(ES) N/A			10. SPONSORING/MONITORING AGENCY REPORT NUMBER	
11. SUPPLEMENTARY NOTES The views expressed in this thesis are those of the author and do not reflect the official policy or position of the Department of Defense or the U.S. Government.				
12a. DISTRIBUTION / AVAILABILITY STATEMENT Approved for public release: distribution is unlimited			12b. DISTRIBUTION CODE	
13. ABSTRACT (maximum 200 words) Conventional warfare between India and Pakistan could inadvertently escalate to nuclear warfare. Asymmetries in military doctrine and capability undermine deterrence stability and could lead to the use of nuclear weapons if the two nations become engaged in a large-scale conventional conflict. Following the 1998 nuclear weapons test, the 1999 Kargil Conflict played out under the nuclear umbrella, but remained very limited. However, there is a growing gap in conventional military capabilities, and growing pressure in India to retaliate against Pakistan for its alleged support of terrorism and insurgency. India has invested heavily in force modernization, potentially changing the scope of conventional military operations and leading to Pakistan's inadvertent use of nuclear weapons. This thesis examines the possibility of inadvertent nuclear escalation between India and Pakistan. It analyzes the deterrence system that is evolving in South Asia, and describes the conditions under which the system could fail. Large-scale conventional war could threaten the survival of strategic forces, or threaten vital strategic command and control functions. Finally, Pakistan could adopt a launch-on-warning posture to guard against an Indian pre-emptive attack. This thesis concludes by recommending steps that the United States could take to ensure peace and decrease de-stabilizing factors in the region.				
14. SUBJECT TERMS India, Pakistan, United States, Nuclear Weapons, Ballistic Missiles, Deterrence, Escalation			15. NUMBER OF PAGES 109	
			16. PRICE CODE	
17. SECURITY CLASSIFICATION OF REPORT Unclassified	18. SECURITY CLASSIFICATION OF THIS PAGE Unclassified	19. SECURITY CLASSIFICATION OF ABSTRACT Unclassified	20. LIMITATION OF ABSTRACT UL	

THIS PAGE INTENTIONALLY LEFT BLANK

Approved for Public Release, Distribution is Unlimited

**ASSESSING THE RISK OF INADVERTENT NUCLEAR WAR BETWEEN
INDIA AND PAKISTAN**

Stephen A. Smith
Major, United States Army
B.A., The Evergreen State College, 1989

Submitted in partial fulfillment of the
requirements for the degree of

**MASTER OF ARTS IN
INTERNATIONAL SECURITY AND CIVIL-MILITARY RELATIONS**

from the

**NAVAL POSTGRADUATE SCHOOL
December 2002**

Author: Stephen A. Smith

Approved by: Peter R. Lavoy
Thesis Advisor

Surinder Rana
Second Reader

James J. Wirtz
Chairman, Department of National Security Affairs

THIS PAGE INTENTIONALLY LEFT BLANK

ABSTRACT

Conventional warfare between India and Pakistan could inadvertently escalate to nuclear warfare. Asymmetries in military doctrine and capability undermine deterrence stability and could lead to the use of nuclear weapons if the two nations become engaged in a large-scale conventional conflict. This is a grave situation given the history of conflict and the ongoing India-Pakistan standoff over the divided state of Kashmir.

Following the 1998 nuclear weapons tests, the 1999 Kargil Conflict played out under the nuclear umbrella. This conflict remained very limited, leading to the expectation that future conflicts will follow the same pattern. However, there is a growing gap in conventional military capabilities, and growing pressure in India to retaliate against Pakistan for its alleged support of terrorism and insurgency. India has invested heavily in force modernization, potentially changing the scope of conventional military operations and making more likely Pakistan's intentional use of nuclear weapons triggered by India unintentionally crossing the "red-line."

This thesis examines the possibility of inadvertent nuclear escalation between India and Pakistan. It analyzes the deterrence system that is evolving in South Asia, and describes the conditions under which the system could fail. It describes the effect that conventional force modernization could have on small nuclear arsenals. Large-scale conventional war could threaten the survival of strategic nuclear forces, particularly those of Pakistan. Conventional war also could damage vital strategic command and control functions. Finally, India's growing conventional military power may cause Pakistan to adopt a launch-on-warning posture where any air or ballistic missile attack could be interpreted as the beginning of a pre-emptive attack. Any of these situations could lead to inadvertent nuclear escalation. This thesis concludes by recommending steps that the United States could take to ensure peace and decrease de-stabilizing factors in the region.

THIS PAGE INTENTIONALLY LEFT BLANK

TABLE OF CONTENTS

I.	INTRODUCTION.....	1
	A. INTRODUCTION.....	1
	B. BACKGROUND	2
	1. Deterrence Theory and Stability	2
	2. Inadvertent Escalation.....	5
	C. ORGANIZATION	8
II.	COMPARISON OF FORCES.....	9
	A. INTRODUCTION.....	9
	B. COMPARING CONVENTIONAL FORCES.....	9
	1. Ground Forces and Role	10
	2. Air Forces and Role	14
	C. COMPARING STRATEGIC FORCES	16
	1. Nuclear Weapons and Fissile Material Capabilities.....	17
	2. Nuclear Delivery Systems.....	20
	D. NUCLEAR DOCTRINE	23
	1. India’s Nuclear Doctrine	23
	2. Pakistan’s Nuclear Doctrine	24
	E. CONCLUSION	26
III.	SURVIVABILITY AT RISK.....	27
	A. INTRODUCTION.....	27
	B. SURVIVABILITY OF STRATEGIC FORCES.....	28
	1. India’s Strategic Depth.....	28
	2. Pakistan’s Lack of Strategic Depth.....	29
	C. CONVENTIONAL WARFIGHTING IN A NUCLEAR ENVIRONMENT.....	30
	1. Historical Example.....	30
	2. Asymmetric Conventional Strategies.....	32
	3. Ground Campaign	33
	4. Air Campaigns	38
	D. CONCLUSION	41
IV.	COMMAND AND CONTROL THREATENED	43
	A. INTRODUCTION.....	43
	B. COMMAND AND CONTROL STRUCTURES.....	44
	1. India’s Strategic Command and Control	45
	2. Pakistan’s Strategic Command and Control.....	48
	C. CONVENTIONAL WARFIGHTING IN A NUCLEAR ENVIRONMENT.....	50
	1. Historical Examples	51
	2. Attacking Command and Control.....	52
	D. ALTERNATE COMMAND AND CONTROL STRUCTURES.....	55
	E. CONCLUSION	56

V.	FEAR OF PRE-EMPTION.....	59
A.	INTRODUCTION.....	59
B.	THE TOOLS OF PRE-EMPTION	60
	1. Historical Example.....	61
	2. Precision Targeting and Attack in South Asia.....	62
C.	EARLY WARNING AND DEFENSE POSTURE	64
	1. India’s Air and Missile Defenses	64
	2. Pakistan’s Air and Missile Defenses.....	65
D.	CONVENTIONAL WARFIGHTING IN A NUCLEAR ENVIRONMENT.....	66
	1. Air Campaign	66
	2. Ballistic Missile Attacks.....	67
E.	CONCLUSION	68
VI.	CONCLUSION	69
A.	FINDINGS.....	69
	1. Survivability at Risk	70
	2. Command and Control Threatened	70
	3. Fear of Pre-emption.....	71
B.	IMPLICATIONS	72
	1. Stability-Instability Paradox.....	72
	2. Crisis Instability in South Asia	73
	3. Future Changes in Force Structure and Doctrine	74
C.	U.S. POLICY.....	76
	1. U.S. Security Concerns	76
	2. U.S. Role in South Asia.....	76
D.	FINAL WORDS	79
	LIST OF ABBREVIATIONS	81
	BIBLIOGRAPHY.....	83
	INITIAL DISTRIBUTION LIST	93

LIST OF FIGURES

Figure 1.	India and Pakistan.....	29
Figure 2.	Possible Indian Ground Attack.....	35
Figure 3.	Possible Pakistani Counter-attack.....	37
Figure 4.	Suggested Nuclear Chain of Command.....	46
Figure 5.	Pakistan's Nuclear Release Authority	49

THIS PAGE INTENTIONALLY LEFT BLANK

LIST OF TABLES

Table 1.	India and Pakistan – Army.....	14
Table 2.	India and Pakistan – Air Force.....	16
Table 3.	Indian and Pakistani Fissile Material and Nuclear Weapons Capability.....	19
Table 4.	India and Pakistan – Ballistic Missiles	22

THIS PAGE INTENTIONALLY LEFT BLANK

ACKNOWLEDGMENTS

The author would like to thank Dr. Peter Lavoy for his guidance, enthusiasm, and patience during the research and completion of this thesis. I would like to give special thanks to Surinder Rana for his insights into the Indian perspective and for keeping me straight on regional history and sensitivities. A special thanks also goes to Dr. Rodney Jones for his superb research that proved so important to my thesis, and for his encouragement. At this time I would like to express my appreciation to the faculty and staff at the Naval Postgraduate School for their superb efforts to provide a first-rate education to all those fortunate enough to attend. Finally, I want to express my thanks to my wife Karyn, and our two daughters, Dana and Nicole, for their love and support over many lost evenings and weekends. Thank you all!

THIS PAGE INTENTIONALLY LEFT BLANK

I. INTRODUCTION

A. INTRODUCTION

Can India and Pakistan fight a conventional war and avoid the use of nuclear weapons? India and Pakistan have had contentious relations since each state gained independence in 1947. This has led to three wars and numerous skirmishes. Both India and Pakistan declared that they were nuclear weapon states following a series of nuclear weapons detonations in May 1998. The addition of nuclear arsenals to this enduring rivalry raises the stakes, not just for India and Pakistan, but also for the rest of the world. This thesis explores the circumstances that could cause conventional warfare between India and Pakistan to escalate inadvertently to nuclear warfare.

Barry Posen, an award winning author and currently a professor of political science at Massachusetts Institute of Technology, developed the framework that I use to examine the possibility of inadvertent nuclear war between India and Pakistan. Posen identified three possible causes of nuclear escalation that are applicable to India and Pakistan. First, conventional attacks could come into direct contact with the adversary's nuclear forces and threaten the survivability of those forces. Second, conventional attacks could degrade the adversary's use of nuclear forces in the time, place, and method of choosing, forcing major changes in its war-fighting strategy, especially if there is a loss of control in the strategic command and control infrastructure. Third, a conventional attack could be mistaken as a pre-emptive strike to destroy or neutralize strategic assets and possibly cause the attacked state to launch its strategic nuclear forces at the first sign of an attack. Any of these scenarios could lead to what Posen calls "inadvertent nuclear escalation."¹ This thesis also follows this sequence, based on how likely these events could lead to inadvertent nuclear war between India and Pakistan.

This thesis analyzes these three conditions in the context of the strategic relationship between India and Pakistan. I use deterrence theory, force posture and doctrine, and the lessons learned from previous conflicts as guides in this analysis. Neither state wants a nuclear war; an intentional nuclear war is very unlikely. I argue

¹ Barry R. Posen, *Inadvertent Escalation* (Ithaca: Cornell University Press, 1989), 2.

that there is a much greater risk of unintentional nuclear war due to the interplay of conventional and strategic forces in an asymmetric environment, characterized by India's superior conventional military power and Pakistan's lack of strategic depth. Steps to stabilize the region and limit the possibility of a crisis escalating to nuclear war must be undertaken. The United States can, and should, play a major role in stabilizing the region due to its close ties with both states.

B. BACKGROUND

Any war fought by nuclear-armed states has the potential to escalate to nuclear use. The use of force entails some degree of risk and potential loss of control and escalation. Predicting how the opponent will react and what impact that it will have on the conflict is part of the cost-benefit analysis. Understanding how deterrence operates is relevant to understanding the potential for escalation in South Asia. I examine how deterrence operates under ideal circumstances. This will be followed by an examination of inadvertent escalation theory, or how deterrence may fail to work in three real world conditions.

1. Deterrence Theory and Stability

How does deterrence work under ideal conditions? Generally, successful deterrence requires three components: capability, communication, and credibility. First, the party fearing attack must have the capability to use nuclear weapons, or any other type of "punishing force" against an aggressor. Second, the threat of retaliation must be clearly communicated to the potential aggressor by a reliable, authorized source. Third, the potential aggressor must understand that the first two elements exist and are credible, that is, a willingness to carry through with the threat exists.²

The first component of successful deterrence is capability. This requires the capability to punish the adversary to such a degree that this adversary is unwilling to risk further provocation. Deterrence optimists, such as Kenneth Waltz, argue that this

² Mario E. Carranza, "An Impossible Game: Stable Nuclear Deterrence After the Indian and Pakistani Tests," *The Nonproliferation Review* (spring/summer 1989), 16.

condition has been facilitated by the addition of nuclear weapons into the arsenals of various states.³ They point to the lack of war between nuclear powers as proof of this concept. This concept attracted many supporters during the Cold War, and many came to believe that the mission of the military in the nuclear age had changed from winning wars, to preventing wars.⁴ However, nuclear weapon states have been involved in wars with non-nuclear weapons states, and limited conflicts have been fought between nuclear powers.

Communication of the threat is the second component of deterrence. This threat must be made by a reliable or authorized source. For deterrence to work it is especially important “to communicate... capability and resolve to adversaries.”⁵ Signaling must be made in a clear manner that is understandable to the adversary. There can be significant problems with communicating a threat intended to deter an adversary. The threat can be lost in a crisis situation due to competing signals and information overload, or because the threat is conveyed in an unexpected manner that the adversary cannot pick up on.⁶

The final component of deterrence is that the adversary must believe that the threat is real, that is, there is a willingness to carry through with the threatened action. This means that for nuclear deterrence to succeed, the adversary must believe that nuclear weapons will be used if it continues with its actions. This is the most complex of the three components. It is based upon the existence of the first two components, capability and a communicated threat, and the belief that retaliation is probable. A nuclear response must appear to be credible, not a bluff.⁷ This may be the most difficult of the three components of nuclear deterrence to establish. Nuclear weapons have not been used in combat since the end of the Second World War. The intervening half-century of history has led many to believe that nuclear weapons only deter the use of nuclear weapons.

³ See Scott D. Sagan and Kenneth N. Waltz, *The Spread of Nuclear Weapons: A Debate* (New York: W.W. Norton and Company, 1995).

⁴ Bernard Brodie, “Implications for Military Policy,” in *The Absolute Weapon: Atomic Power and World Order*, ed. Bernard Brodie (New York: Harcourt, Brace, and Company, 1946), 76.

⁵ Richard Ned Lebow, “Conclusions,” in *Psychology and Deterrence*, ed. Robert Jervis, Richard Ned Lebow, and Janice Gross Stein (Baltimore: The Johns Hopkins University Press, 1985), 205.

⁶ *Ibid.*, 205-211.

⁷ David W. Tarr, *Nuclear Deterrence and International Security: Alternative Nuclear Regimes* (New York, Longman, 1991), 68-69.

Establishing deterrence is critical. However, once established the general goal is to maintain it over time. Stable nuclear deterrence is obtained when the following four requirements are met. All of these requirements can be considered as part of the capability portion of deterrence. First, the nuclear weapons must be technically reliable; that is, they must have a proven performance. Second, both sides must develop a secure second-strike capability, that is, strategic forces must be able to survive an attack and retaliate against the aggressor. Third, neither side can believe that it can destroy the opponent's nuclear capability in a pre-emptive attack. Finally, the nuclear forces must be secure against unauthorized or accidental use.⁸ India and Pakistan met the first requirement in May 1998; the other three requirements have not been fully met, as will be demonstrated below.

Finally, a key component of a stable nuclear deterrence is crisis stability, which has been defined as “a measure of a country's incentives not to pre-empt in a crisis.”⁹ This involves a cost-benefit analysis of whether a first-strike will succeed and incapacitate the opponent's second-strike nuclear capability. Small strategic arsenals, such as those of India and Pakistan, may provide an incentive for an opponent to pre-empt. Such a threat, if credible, or assumed to be credible, could undermine confidence that sufficient strategic forces would survive, and therefore undermine deterrence stability. The advent of precision-guided munitions in South Asia combined with the increased technical sophistication of intelligence gathering and targeting assets, may allow small nuclear arsenals to be severely damaged, if not completely destroyed, by conventional forces.¹⁰

The United States and the Soviet Union met the four requirements for stable nuclear deterrence and achieved crisis stability. Both conventional and nuclear war was

⁸ Carranza, “An Impossible Game,” 16.

⁹ James J. Wirtz, “Beyond Bipolarity: Prospects for Nuclear Stability after the Cold War,” in *The Absolute Weapon Revisited: Nuclear Arms and the Emerging International Order*, ed. T.V. Paul, Richard J. Harknett, and James J. Wirtz (Ann Arbor: University of Michigan Press, 1998), 142.

¹⁰ The U.S. 2001 Nuclear Posture Review recognizes that a new triad exists, with conventional munitions assuming a major role in the new deterrence posture. U.S. Department of Defense, *Findings of the United States Nuclear Posture Review*, 9 January 2002, at <<http://www.defenselink.mil/news/Jan2002/g020109-D-6570C.html>>; Donald H. Rumsfeld, *Nuclear Posture Review Foreward*, 9 January 2002, at <<http://www.defenselink.mil/news/Jan2002/d20020109npr.pdf>>; and J.D. Crouch, *Briefing on the Nuclear Posture Review*, 9 January 2002, at <<http://usinfo.state.gov/topical/pol/arms/stories/review.htm>>.

avoided partly as a result of this. Hundreds of nuclear weapons tests were conducted, proving the technical capability of both arsenals to do tremendous damage, if not destroy the world. The United States and the Soviet Union developed nuclear triads made up of an air component, land-based missiles, and submarine-based missiles to ensure survivability, thus meeting the second requirement. Both sides attempted to develop a pre-emptive or decapitating first-strike capability, however, the robustness of the triad coupled with the inability to destroy sufficient numbers of the opponent's incoming warheads if the first-strike failed put that possibility to rest, thereby meeting the third requirement. Both the United States and Soviet Union developed robust command and control systems and technically sophisticated nuclear weapons featuring advanced negative controls to guard against unauthorized or accidental use of nuclear weapons.

Many knowledgeable observers fear that new nuclear states will not be able to develop a stable deterrence capability. This is the crux of the proliferation pessimist argument, as advanced by Scott Sagan.¹¹ Posen surmised, “these countries are unlikely to deploy nuclear weapons in ways that enhance stability” due to the inability to provide survivable retaliatory forces in “numbers, basing modes, or early warning capabilities.”¹² These warnings ring more true today. The tremendous efforts made by the United States and the Soviet Union during the Cold War to build secure second-strike capabilities, robust command and control capabilities, and effective early warning systems have not been matched by India and Pakistan. This leads to greater instability and increases the risk of inadvertent nuclear escalation. Additionally, as Posen hypothesized, conventional forces may pose a threat to strategic forces. This is especially true in the case of India and Pakistan, which have sought to develop a minimum deterrence capability at a much lower cost, compared to the superpowers.

2. Inadvertent Escalation

What is escalation? Is there a difference between deliberate escalation and inadvertent escalation? These questions were asked during the Cold War, and some

¹¹ Sagan and Waltz, *The Spread of Nuclear Weapons; A Debate*.

¹² Posen, *Inadvertent Escalation*, 200.

understanding was reached that can help us in the context of a crisis in South Asia. Escalation of any kind is due to deterrence failing.

Escalation has been described as a process of increasing efforts in some way in the hope of gaining success, especially if the other side does not undermine this effort by responding in kind.¹³ Escalation is when “a would be escalator can increase, or threaten to increase his efforts: by increasing intensity, widening the area, or compounding escalation.”¹⁴ Herman Kahn outlined a process of escalation involving 44 rungs that ranged from a limited crisis to full-scale thermonuclear war. This initial concept of escalation as developed during the Cold War came to mean to expand or spiral upward. The most widely understood threshold in modern warfare is the distinction between the use of conventional and nuclear weapons.¹⁵

The decision to escalate is “a strategic issue, involving...difficult and often painfully uncertain calculation of the possibility of counter escalation by the enemy.”¹⁶ The decision to escalate is a cost-benefit analysis to expand or increase efforts in the hopes to gain success or win, and could include nuclear escalation. This is in stark contrast to Posen’s description of inadvertent escalation, where crossing the nuclear threshold is accidental and due to the unexpected results of conventional attacks. These escalation producing conventional attacks could take a number of forms, but the following three are the most likely, and will be used in this thesis. First, conventional attacks could affect the survivability of the adversary’s strategic arsenal. Secondly, conventional attacks could degrade the strategic command and control of the adversary’s nuclear forces. Finally, conventional attacks could be mistaken for a pre-emptive first-strike and start a nuclear alert cycle and cause a launch on warning.

The difference between deliberate escalation and inadvertent escalation may be easiest to illustrate by using a well-known case study. During the Cuban Missile Crisis of

¹³ Herman Kahn, *On Escalation: Metaphors and Scenarios* (New York: Frederick A. Praeger, 1965), 3.

¹⁴ *Ibid.*, 4.

¹⁵ For a more detailed explanation of escalation see Richard Smoke, *War: Controlling Escalation* (Cambridge, Mass.: Harvard University Press, 1977), 19–23; Bernard Brodie, *Escalation and the Nuclear Option* (Princeton: Princeton University Press, 1966), 103-112; and Herman Kahn, *On Escalation: Metaphors and Scenarios*, 94.

¹⁶ Smoke, *War: Controlling Escalation*, 4.

1962, and after intense deliberation by the senior leadership, the United States announced a quarantine of Cuba. The armed forces of the United States, including the nuclear forces, were put on full alert. This was a deliberate escalation on the part of the United States, and served as a profound warning to the Soviet Union of the seriousness of the situation.

At the same time that these deliberate actions were taking place, a series of unattended events transpired. A U2 reconnaissance over-flight of the Soviet Union proceeded as scheduled, as well as a missile launch from Vandenberg Air Force Base. These incidents could have been mistaken as a nuclear attack on the Soviet Union, and prompted the Soviets to launch a retaliatory nuclear strike against the United States. A U2 was shot down over Cuba on 27 October, and U.S. tactical aircraft were prepared to attack the Soviet surface-to-air missile (SAM) sites in Cuba. The results of such an attack could have been disastrous, putting conventional systems in direct contact with nuclear systems, and threatening the survival of the Soviet nuclear-armed missiles. U.S. intelligence thought that the Soviet missiles were operational, and that there were nuclear weapons somewhere in Cuba. The nuclear warheads themselves had arrived in Cuba on 4 October. Post-crisis imagery analysis showed that some warheads had been mated to the missiles when the crisis reached its peak. Individual missile battery commanders had the ability to launch the nuclear-armed missiles since there were no negative control features on early Soviet missiles and nuclear weapons.¹⁷ How close the world really came to nuclear warfare was fully appreciated only when classified documents were released following the end of the Cold War.

Posen analyzed how conventional military operations between NATO and the Warsaw Pact could have escalated into nuclear war in *Inadvertent Escalation*. He defined inadvertent escalation as conventional warfare that accidentally rises to nuclear warfare. This is in direct contrast to deliberate escalation, where the potential for nuclear

¹⁷ How close the world came to inadvertent nuclear escalation during the Cuban Missile Crisis has been revealed only since the end of the Cold War allowed a full discussion from all perspectives. For a thorough discussion of the operational readiness of Soviet missiles during the Cuban missile crisis see Dino A. Brugioni, *Eyeball to Eyeball: The Inside Story of the Cuban Missile Crisis* (New York: Random House, 1990), 452-463 and 538-548; Aleksandr Fursenko and Timothy Niftal, *One Hell of a Gamble: Khrushchev, Castro, and Kennedy, 1958-1964* (New York: W.W. Norton and Company, 1997), 217; and *CIA Documents on the Cuban Missile Crisis, 1962*, ed. Mary S. McAuliffe, CIA History Staff (Washington, D.C.: CIA, 1992), a collection of declassified documents pertaining to the subject.

warfare is either accepted as a risk, or deliberate steps are taken to use nuclear weapons. The analysis of the current situation in South Asia requires a comparison of conventional forces, strategic forces, and nuclear doctrine to assess whether similar conditions exist today on the subcontinent.

C. ORGANIZATION

This thesis examines the potential for conventional conflict between India and Pakistan to inadvertently escalate to the use of nuclear weapons. Conventional warfare could theoretically lead to nuclear escalation under certain conditions. Understanding those conditions could provide a basis for limiting any conventional conflict between India and Pakistan to ensure that those conditions are not met. The forces that bear on this situation include conventional forces and doctrine, strategic nuclear forces and doctrine, and possible interaction between the conventional and strategic systems that could lead to inadvertent use of nuclear weapons.

This thesis has six chapters. Chapter I introduces the theoretical aspects of deterrence and inadvertent escalation. Chapter II analyzes the conventional and strategic balance in South Asia. Chapter III presents a case study of how the survivability of the strategic nuclear weapons systems could be threatened, potentially leading to inadvertent nuclear escalation. Chapter IV consists of a case study on the potential for the loss of command and control of strategic forces in South Asia, thereby leading to nuclear escalation. Chapter V outlines the risks that advanced offensive and defensive conventional weapons present to India and Pakistan's small strategic arsenals, potentially causing any conventional attack to be mistaken for pre-emption of the strategic systems, and causing a launch-on-warning. Chapter VI concludes with a findings, implications, and recommendations for U.S. policy.

II. COMPARISON OF FORCES

A. INTRODUCTION

The study of the potential for inadvertent nuclear escalation in South Asia must be based on an assessment of the conventional military and strategic nuclear forces that could play a role in a military conflict. This chapter analyzes the conventional and strategic balance in South Asia, with a focus on those forces that could be employed in a conflict. This chapter describes the military asymmetries that currently exist in South Asia. It begins by comparing conventional military forces, focusing on ground and air forces, and includes the doctrinal roles of these forces. Strategic forces are then compared, including both nuclear weapons and their delivery systems. Finally, India and Pakistan's nuclear doctrines are compared.

These comparisons yield important results. India has achieved numerical and qualitative superiority in many categories, particularly in mechanized ground forces and in attack aircraft. India is also improving its military forces at a rate that Pakistan cannot match due to a lack of resources. Both India and Pakistan have relatively small nuclear arsenals. Pakistan is continuing to fall behind in aircraft quality and quantity, and has put a much greater emphasis on ballistic missiles as nuclear delivery systems. India had the initial lead in missile technology, but failed to follow through and lost its advantage. India enjoys a tremendous advantage in both quantity and quality of nuclear capable aircraft, and is currently putting more emphasis on its missile program. This asymmetry of military means is reinforced by the asymmetry of methods, especially in nuclear doctrine. Pakistan has attempted to offset India's conventional advantage by building a nuclear deterrent, including a first-use option, while India has a retaliatory doctrine and nuclear forces that are primarily designed to deter nuclear attack. These factors have a tremendous influence on the potential for inadvertent escalation.

B. COMPARING CONVENTIONAL FORCES

The conventional military balance in South Asia is in India's favor. It is the larger of the two countries in territory, population, and in economic capacity. This gives

India an advantage that Pakistan has attempted to address throughout its history in different ways. Pakistan was able to maintain a qualitative superiority in conventional arms until the 1970s. Pakistan lost U.S. support and India aligned itself with the Soviet Union during the 1970s. India was able to close the qualitative gap with Pakistan due to the combination of Soviet assistance and greater economic resources. A cursory examination shows that India has a greater number of personnel on active military duty, more tanks, and more combat aircraft.¹⁸ A thorough discussion of conventional forces is provided. These forces are grouped into ground and air components for the sake of clarity.

1. Ground Forces and Role

India's army is the largest and most prestigious of India's services and consists of 1,100,000 active duty personnel (see Table 1). The Indian army is a highly trained and highly professional service. The Chief of Army Staff (COAS) is the senior Army leader, and Army headquarters are located in New Delhi. The Indian Army consists of five major regional commands and a training command. The bulk of the armored and mechanized forces are part of Western Command and are adjacent to the Pakistan border. The army is based upon a corps model (twelve corps currently) for tactical control. India has four premier Reinforced Army Plains Infantry Divisions (RAPID), made up of mixed armor and mechanized infantry units, and 3 armor divisions, 18 infantry divisions, and 9 mountain divisions.¹⁹

India has many fairly modern tanks, infantry fighting vehicles, and other weapon systems. These include T-72 and T-90 tanks and BMP-1 and BMP-2 infantry fighting vehicles and equivalent indigenously produced weapons. India also has a large artillery force, primarily consisting of towed howitzers. There are insufficient quantities of self-

¹⁸ "Executive Summary, Pakistan" in *Jane's Sentinel Security Assessment South Asia*, no. 10 (3 September 2002), 5, at <<http://online.janes.com/>>; Anthony H. Cordesman, *The Conventional Military Balance in India Pakistan and South Asia: A Comparative Summary of Military Expenditures; Manpower; Land; Air; and Naval Forces; and Arms Sales* (Center for Strategic and International Studies, 27 December 2001), 6-7; and Sumit Ganguly, *Conflict Unending: India-Pakistan Tensions since 1947* (New York: Columbia University Press, 2001), 47-48.

¹⁹ "Army, India," in *Jane's Sentinel Security Assessment South Asia*, no. 10 (31 May 2002), 1-7, at <<http://online.janes.com/>>; and Cordesman, *The Conventional Military Balance*, 9-11.

propelled howitzers to support the armored and mechanized forces, and there is a new requirement for 600 howitzers. A mixture of low to high-level SAM and air defense artillery provide a fairly good air defense. The bulk of the Indian Army consists of light infantry armed with small arms and mortars and supported by towed artillery. Many of these units are deployed in the mountainous regions bordering Pakistan and China, which requires a commitment of nine infantry divisions.²⁰

India has developed an offensive-defensive military doctrine that calls for aggressive offensive action to pre-empt or counter-attack the enemy, thereby gaining the initiative. Currently, India is exploring the concept of limited conventional war based on the concept of strategic space between low-intensity, or proxy conflicts such as Kashmir, and full-scale conventional war. This concept is fueled by political and public pressure within India to launch a conventional attack on Pakistan in retaliation for Pakistan's alleged support of terrorism.²¹ A limited attack is designed to overcome the stability-instability paradox, or the use of nuclear deterrence to support conventional aggression.²² India is very much aware of Pakistan's military and geographic weaknesses, and has concentrated most of its conventional military power where it can threaten to cut Pakistan in two and defeat the Pakistan Army using a mechanized thrust by the strike corps. The Indian Army mounted a major counter-offensive towards Lahore during the 1965 War while attacking simultaneously in the Sialkot region that nearly succeeded in accomplishing exactly that. Chapter Three will explore these concepts further.

The Pakistani Army is also highly professional, well trained, and enjoys a great deal of status within Pakistan, although this reputation has been tarnished in recent months due to President Musharraf's manipulation of the Pakistani political process and the Army's continuing role in government. The COAS is the senior military leader. Army headquarters are located in Rawalpindi. Force structure is comprised of nine corps; the most important are the two strike corps and three corps defending the border

²⁰ Ibid; and "New Indian 155 mm Self-Propelled Artillery System," in *Jane's Armour and Artillery*, no. 22, ed. Christopher F. Foss (Coulson, UK: Jane's Information Group, 2002) 123-124.

²¹ Guarav Kampani, "Placing the Indo-Pakistani Standoff in Perspective," at *CNS Web Reports*, 8 April 2002, 14-15, at <<http://cns.miis.edu/pubs/reports/pdfs/indopak.pdf>>.

²² V.R. Raghavan, "Limited War and Nuclear Escalation in South Asia," *The Proliferation Review* (fall/winter 2001), 83.

with India. The army's total strength is 550,000 personnel on active duty, organized into 19 infantry divisions, 2 armored divisions, and 7 independent armored brigades (see Table 1).²³

Pakistan's armor forces consists of U.S., Soviet-type, and Chinese manufactured tanks and infantry vehicles, with no true infantry fighting vehicles. Much of this equipment is obsolete, though well maintained. Pakistan's best tanks are the Ukrainian T-80 and the older U.S. M48A5. Pakistan's artillery is a mixture of U.S. and Soviet cannons, mostly towed. Sufficient self-propelled howitzers are available to support the premier armor and mechanized units. Pakistani air defense relies upon large quantities of man-portable SAMs and light air-defense cannons. The bulk of Pakistan's army consists of light infantry similar to that of India, and is armed in a similar manner. The utility of light forces on the mechanized battlefield is probably limited, but they can perform admirably in more constrained terrain. Another potential weakness is the poor coordination of air support between the Army and the Air Force.²⁴

Pakistan has been unable to keep pace with India's conventional military growth. A major obstacle is simply expense, even though Pakistan spends at double the GDP rate of India (averaging about six percent per year compared to about three percent). Pakistan's defense expenditures were less than U.S. \$4 billion in 2000, compared to India's defense expenditures of about U.S. \$18 billion. The Army gets the biggest share of Pakistan's military budget, although a growing percentage has been spent on strategic systems rather than on ground forces.²⁵

The Pakistani army relies upon the offensive-defensive strategy, which is characterized by retaining adequate reserves at successive force levels, surprise, and aggressive leadership. This strategy, originally devised by General Aslam Beg and first tested during the 1989 Zarb-e-Momin exercises, calls for the Pakistan Army to discern

²³ "Army, Pakistan," in *Jane's Sentinel Security Assessment, South Asia*, no. 10 (31 May 2002), 1-5, at <<http://online.janes.com/>>; and Cordesman, *The Conventional Military Balance*, 9-11.

²⁴ Ibid.

²⁵ Rodney W. Jones, *Force Modernization Trends-India and Pakistan* (Policy Architects International, 23-25 October 2001) 10-12, at <http://www.policyarchitects.org/pdf/ForceModern_IndiaPakistan2.pdf>; and Rodney W. Jones, *Military Asymmetry and Instability in Emerging Nuclear States: India and Pakistan* (Policy Architects International, March 2002), at <http://www.policyarchitects.org/pdf/NucStability_IndiaPakistan1.pdf>.

the initial enemy thrust, take effective counter measures to limit penetration, and simultaneously attack the adversary to capture/threaten a strategic objective.²⁶ However, the two wars (1965 and 1971) with India saw Pakistan launching the initial major attacks with its main strike corps in the heart of Punjab, aiming to capture strategic objectives/territory, which could be used as a bargaining chip, or to show success for both internal and external consumption. A second strike corps, also called the army reserve south, is kept in reserve to counterattack against a subsequent offensive, or launch an offensive along a different axis.²⁷

India has a significant numerical advantage in armored and mechanized forces. It has a two-to-one advantage in tanks and a three-to-one advantage in modern tanks. India also has true infantry fighting vehicles, giving its mechanized infantry much more firepower and mobility than the Pakistani infantry. The qualitative gap between the Indian and Pakistani armies is continuing to grow since India has been able to purchase or develop more modern military equipment.²⁸ Joint operations between India's armed services are progressing, and all arms cooperation, particularly in the RAPID units, are well established. The Indian army is moving slowly but surely from an infantry centered model to a more modern mechanized force, giving it greater offensive capability.²⁹ Equipment plays an important role in analyzing the relative capability of a military force. Numbers are important, but the quality of equipment and level of training are equally important. Pakistanis contend that the quality of their armed services can make up for the lack of military capability on paper.³⁰ Internal security requirements are growing in India, and may detract from military readiness. India also may have to plan on guarding

²⁶ General Mirza Aslam Beg, "Deterrence, Defense and Development," *Defense Journal* (July 1999), at <http://www.defencejournal.com?jul99/deterrence.htm>; Jane's, "Army, Pakistan," 1-5; Cordesman, *The Conventional Military Balance*, 9-11; and Firdaus Ahmed, "The Need to Revisit Conventional Doctrine," 11 August 2002, at <http://www.ipcs.org/issues/800/816-ndi-firdaus.html>.

²⁷ See Brian Cloughley, *A History of the Pakistan Army: Wars and Insurrections* (Oxford: Oxford University Press, 1999), 341; Jane's, "Army, Pakistan," 1-5; and Cordesman, *The Conventional Military Balance*, 9-11.

²⁸ Jones, *Force Modernization Trends-India and Pakistan*, 10-12; and Jones, *Military Asymmetry and Instability in Emerging Nuclear States: India and Pakistan*.

²⁹ Jane's, "Army, India," 1-7; and Cordesman, *The Conventional Military Balance*, 9-11.

³⁰ Ahmad Faruqi, "Military Scales Don't All Tip India's Way," *Defence Journal* (April 2002), at <http://www.defencejournal.com/2002/april/military.htm>.

its border with China, further diluting its military strength.³¹ Another major factor in war fighting ability is the sustainment of military forces. India has the capability to produce and repair major pieces of military equipment, giving it a significant advantage in a longer war of attrition.

Table 1. India and Pakistan – Army³²

	Personnel	Tanks	Light Armor	Artillery (see note)
India	1,100,00	3,700	1,800	3,600 (T) /180 (SP)
Pakistan	550,000	2,500	500	2,000 (T) /270 (SP)

Note: (T) is towed artillery; (SP) is self-propelled artillery

2. Air Forces and Role

The Indian Air Force (IAF) is the fourth largest in the world, and is highly regarded for its professionalism. Its headquarters are in New Delhi, and there are six regional operational commands. The senior officer is the Chief of Air Staff. India has moved most of its strike aircraft out of range of air attack from potential enemies.³³

The IAF has a total strength of 150,000 personnel, and about 736 combat aircraft (see Table 2). These aircraft are a mixture of French, British, and Russian planes, primarily fighters or fighter-bombers, but with some bombers. The most common aircraft are the MiG-21 and the MiG-27. The MiG-21s are currently undergoing an upgrading process to extend both their life cycle and capabilities. India has attempted to manufacture an indigenous strike aircraft, Light Combat Aircraft, which is currently being tested. The IAF also has a growing long-range strike capability, which includes British Jaguar and Sukhoi SU-30 aircraft. The Minister of Defense and Air Force Chief Marshall announced that the first squadron of SU-30s was operational on 27 September 2002, and also noted the possibility of purchasing six air-to-air refueling tankers from

³¹ Cloughley, *A History of the Pakistan Army*, 339.

³² After Jane's, "Executive Summary, Pakistan," and Cordesman, *The Conventional Military Balance*, 6-7.

³³ "Air Force, India," in *Jane's Sentinel Security Assessment South Asia*, no. 10 (31 May 2002), 1-5, at <<http://online.janes.com/>>; and Cordesman, *The Conventional Military Balance*, 13-14.

Uzbekistan.³⁴ There is a shortage of in-flight refueling capability and of airborne early warning. However, these may receive a higher priority and increased funding in the future. India has experienced a high aircraft accident rate and has a shortfall of trained pilots. India has developed some indigenous production and maintenance facilities that play a major role in sustaining the force.³⁵

India's air doctrine is designed to support the offense-defense doctrine. The four components of Indian air doctrine are counter-air, destruction of enemy defense infrastructure, interdiction of enemy ground forces, and close air support. The IAF focused on close air support up to the 1971 War, but has since grown more independent and gained a wider variety of roles, including deep strike and maritime patrolling. The development and purchase of advanced and precision-guided munitions gives the Air Force a growing capability.³⁶ The IAF also may have a nuclear attack role since India is still developing and testing ballistic missiles.

The Pakistani Air Force (PAF) is assessed as being a well-trained, professional force. It established a good operational record in the wars with India. The PAF is headquartered in Chaklala, close to Islamabad, and consists of three major commands: Central, Northern, and Southern. It consists of eighteen squadrons, with greatest importance attached to the Central Command, which includes the capital and portions of the border with India.³⁷

The PAF has approximately 414 combat aircraft and personnel strength of about 45,000 (see Table 2). Most of Pakistan's combat aircraft are multi-role fighter-bombers; useful for both air defense and close air support. The aircraft are a mixture of U.S., French, and Chinese manufacture. The diversity of aircraft types and suppliers is probably a factor in the overall logistical problems experienced by the air force. Pakistan requires external support of parts and other equipment to maintain its aircraft. The U.S.

³⁴ Rajat Pandi, "IAF Inducts Sukhoi-30MKI" in *Times of India* (28 September 2002), 1.

³⁵ See Rahul Bedi "Technical and Cost Problems stall India's LCA," *Jane's Defense Weekly* (2 April 2000); "MOU Signed for LCA Production" *Times of India* (7 June 2002) at <<http://www.hinduonnet.com/thehindu/2002/06/07/stories/2002060702161200.htm>>; Jane's, "Air Force, India," 1-5, and Cordesman, *The Conventional Military Balance*, 13-14.

³⁶ Jones, *Force Modernization Trends-India and Pakistan*, 11.

³⁷ "Air Force, Pakistan," in *Jane's Sentinel Security Assessment, South Asia*, no. 10 (31 May 2002), 1-4, at <<http://online.janes.com/>>; and Cordesman, *The Conventional Military Balance*, 13-14.

arms embargo has had a significant impact on the operational readiness of Pakistan’s F-16s, its most capable aircraft. Pakistan has been able to upgrade some of its fighters, but many of these aircraft are past their prime, having been superseded by more modern aircraft in better-funded air forces.³⁸ Pilots receive about 210 flying hours per year, and have been able to achieve and maintain good proficiency.³⁹

The Indian Air Force has a qualitative and quantitative advantage over the Pakistani Air Force. The Mirage 2000, SU-30, and MiG-29 aircraft are much more modern than aircraft in the Pakistani Air Force, including the F-16. The two-to-one overall advantage in aircraft grows to almost a six-to-one advantage when one compares just the most modern and capable aircraft.⁴⁰ This has led some to contend that India would gain air superiority within several days of hostilities under general combat conditions, a position with which Pakistan strongly disagrees.⁴¹

Table 2. India and Pakistan – Air Force⁴²

	Personnel	Combat Aircraft
India	150,00	736
Pakistan	45,000	414

C. COMPARING STRATEGIC FORCES

Strategic forces include nuclear weapons and their delivery systems and the doctrine that guides their usage. The information used in this thesis is based upon unofficial sources or estimates, given that these are closely guarded state secrets. The available information does allow for a good understanding of the state of weaponization, including weapon design, type of fissile material, yield, and delivery systems. It is also

³⁸ Jones, *Force Modernization Trends-India and Pakistan*.

³⁹ Jane’s, “Air Force, Pakistan,” 1-4; and Cordesman, *The Conventional Military Balance*, 13-14.

⁴⁰ Jones, *Force Modernization Trends-India and Pakistan*.

⁴¹ Rodney W. Jones, *Pakistan’s Nuclear Posture: Quest for Assured Nuclear Deterrence-A Conjecture*, vol. 19 (Islamabad: Institute of Regional Studies, January 2002), 22-23; and Air Commodore (Retd) Jamal Hussain, “Pakistan’s Excellence in Air Combat: PAF’s Forte,” *Defence Journal*, April 2002, at <<http://defencejournal.com/2002/april/combat.htm>>.

⁴² After Jane’s, “Executive Summary, Pakistan,” and Cordesman, *The Conventional Military Balance*, 6-7.

probably fair to say that the semi-official pronouncements of nuclear policy are close to the actual policies, and can serve as a basis for the later application of conditions under which conventional warfare could escalate to nuclear warfare.

1. Nuclear Weapons and Fissile Material Capabilities

The exact number of India's nuclear weapons is a closely guarded state secret; however, there are a number of estimates available. On the low end of the spectrum, David Albright estimated that India had accumulated between 240 kg and 395 kg of weapons grade plutonium by 1999 (see Table 3). At 4.5 kg per bomb, this would be sufficient for approximately 65 bombs with a nominal yield of 10 to 20 kilotons if the weapons were simple fission bombs.⁴³ Ashley Tellis' low estimate corresponds to Albright's. However, Tellis also gives several other data points. The medium estimate is approximately 450 kg of plutonium, equating to about 90 nuclear weapons at five kg per weapon. The highest figure is 570 kg, which equals 115 nuclear weapons.⁴⁴ Peter Lavoy added additional quantities plutonium to these amounts to update the estimates to the 2002 timeframe.⁴⁵

If India is able and willing to use reactor-grade plutonium in the manufacture of nuclear weapons the above estimates may be low. Reports following the Pokhran test indicated that one of the bombs tested might have been made from "dirty plutonium." This is understood to mean non-weapons grade or reactor-grade plutonium. India has a large amount of reactor-grade plutonium since it has been running nuclear power stations for years. Additionally, India has a long-standing effort to produce highly enriched uranium (HEU) for its planned nuclear submarine, or advanced technology vehicle (ATV). When produced, this material could be used for nuclear weapons, giving India access to a significant increase in weapon grade material.⁴⁶

⁴³ David Albright, "India's and Pakistan's Fissile Material and Nuclear Weapons Inventories, end of 1999," (Institute for Science and International Security, 11 October 2000), at <<http://www.isis-online.org/publications/southasia/stocks1000.html>>.

⁴⁴ Ashley Tellis, *India's Emerging Nuclear Posture: Between Recessed Deterrent and Ready Arsenal* (Santa Monica: RAND, 2000), 55-56, 484.

⁴⁵ Peter R. Lavoy, "Fighting Terrorism and Avoiding War in South Asia: U.S. Relations with India and Pakistan after 11 September," forthcoming in *Joint Forces Quarterly*, Autumn 2002.

⁴⁶ Tellis, 231.

How many nuclear weapons does India need to feel secure? This is tied closely to India's doctrinal requirements for nuclear weapons, what they will be used for, and who will be deterred. India has not officially announced how many nuclear weapons it requires, but K. Subrahmanyam made statements that India initially needed about 60 weapons in 1994, later changed to 150 nuclear weapons in 1999.⁴⁷

Pakistan's nuclear weapons are based upon HEU produced by high-speed centrifuges, and total production is very difficult to assess. Estimates range from low to high in the total amount of special materials and number of weapons (see Table 3). Tellis provided a low figure of about 200 kg of HEU, and using 15 kg as the baseline amount needed for a simple fission weapon, this leads to about thirteen bombs producing a nominal yield of some 10 to 20 kilotons. His medium estimate, based upon continued HEU production, is about 400 kg of HEU, equating to approximately 23 to 26 weapons.⁴⁸ Albright estimated that Pakistan had about 690 kg of HEU in 1999, and again using 15 kg as the baseline amount needed for a weapon, this leads to about 46 weapons.⁴⁹ HEU production could be re-started at any time, especially if Pakistan has already produced low or medium enriched uranium. 175-200 kg of HEU could be produced within weeks, effectively doubling Pakistan's weapons inventory. Peter Lavoy again extrapolates these estimates out to 2002.⁵⁰

Pakistan may now also produce weapons-grade plutonium at the Khushab reactor. This reactor was commissioned in 1998, and is reportedly capable of producing about 10 to 15 kg of plutonium a year, equating to two to three weapons of more compact design than those of HEU. How much has been reprocessed is unknown.⁵¹ Plutonium not only would augment Pakistan's fissile material, but also would add to the size of its nuclear arsenal as by as many as a dozen if Khushab has been able to produce weapons grade plutonium at full capacity since commissioned. Perhaps most importantly, plutonium gives a more compact design, perhaps important in the weaponization process. Pakistan

⁴⁷ Ibid, 485.

⁴⁸ Ibid, 55-57.

⁴⁹ Albright, *India's and Pakistan's Fissile Material and Nuclear Weapons Inventories*.

⁵⁰ Lavoy, "Fighting Terrorism and Avoiding War in South Asia."

⁵¹ Tellis, *India's Emerging Nuclear Posture*, 56-57; Albright, *India's and Pakistan's Fissile Material and Nuclear Weapons Inventories*.

may have requirements for 70 nuclear weapons to meet its strategic needs, according to claims made by Pakistani scientists in 1998. Other Pakistani officials felt that the number of nuclear weapons was irrelevant since even limited numbers could serve as a useful deterrent.⁵²

The May 1998 nuclear tests by India and Pakistan provide a baseline for data on nuclear yields. India’s claimed yields were 43 kilotons, 12 kilotons, and a third device of less than a kiloton. Two other tests had minimal yields, and may have been used to test other design features.⁵³ However, seismic data puts these figures in doubt, and range from an estimated total yield from as low as 10 kilotons, to as high as 25-30 kilotons, with the latter figures thought to be the most accurate. Pakistan claimed yields of 25 and 12 kilotons, with the rest being less than one kiloton. In this case, seismic data also did not support the announced yields, and yields were estimated on the order of 9-12 kilotons total for the 28 May test, and 4-6 kilotons for the 30 May test.⁵⁴ While the total yield of the tests can be debated, the fact that both India and Pakistan have produced and tested weapons with sufficient yield to provide for significant destruction is proven. These yields would also seem to indicate that only simple fission weapons have been tested. Both sides also have sufficient numbers of weapons even at the lowest estimated numbers to do tremendous damage in a nuclear exchange.

Table 3. Indian and Pakistani Fissile Material and Nuclear Weapons Capability⁵⁵

	Weapon-Grade Plutonium (kg)			Weapon-Grade Uranium (kg)			Weapon Capability		
	Low	Medium	High	Low	Medium	High	Low	Medium	High
India	280	400	600	Unknown	Unknown	Unknown	40	70	120
Pakistan	5	15	45	815	1020	1230	35	60	95

⁵² Umer Farooq, “Pakistan Needs Up To 70 Nuclear Warheads,” *Jane’s Defense Weekly*, 10 June 1998, 3.

⁵³ David Albright, “The Shots Heard ‘Round the World,” in *Bulletin of the Atomic Scientists*, vol. 54, no. 4 (July/August 1998), 1, at <<http://www.thebulletin.org/issues/1998/ja98/ja98albright.html>>.

⁵⁴ “Pakistan’s Nuclear Forces, 2001,” in *NRDC Nuclear Notebook, Bulletin of the Atomic Scientists*, 7 June 2002, at <<http://www.thebulletin.org/issues/nukenotes/jf02nukenote.html>>.

⁵⁵ Lavoy, “Fighting Terrorism and Avoiding War in South Asia.”

2. Nuclear Delivery Systems

India probably still relies upon aircraft for the nuclear delivery mission, even though India pursued ballistic missile technology beginning at an early date. These missiles may also be nuclear delivery systems, though the operational capability may not be as well established as the aircraft.⁵⁶ India's nuclear-capable aircraft consist of the Jaguar, Mirage 2000, and Sukhoi SU-30s, with the SU-30 being the most capable, even if primarily designed as an air superiority fighter. The SU-30 is a two-seat aircraft and is capable of great range due to in-flight refueling, and has hard points for weapons and fuel up to 8,000 kg.⁵⁷ India is reported to be leasing two to four long-range TU-22 Backfire bombers from Russia, and has options to lease more.⁵⁸ Claims have been made that India has fully tested simulated nuclear weapons with the Mirage 2000 aircraft.⁵⁹ It is important to note that all of these aircraft are capable of being used in conventional roles, a fact that probably complicates Pakistani defensive measures.

India has also tested and produced several missile systems including the Prithvi 1 and 2 short-range ballistic missiles (SRBM), and the Agni medium range ballistic missiles (MRBM) (see Table 4). Approximately 75-150 Prithvi 1 have been produced.⁶⁰ These missiles belong to the Army's 333 Missile Group, and are stationed close to the Pakistani border. The Prithvi 1 is most likely to have a tactical role because of its short range, even though it is technically capable of carrying nuclear warheads.⁶¹ The Air Force is currently fielding the Prithvi 2, and may have as many as 25-50 on-hand.⁶² The

⁵⁶ Andrew Koch, "India, Pakistan: Nuclear Arms Race Off to a Slow Start," *Jane's Intelligence Review* (1 January 2001), 36-40.

⁵⁷ "Dassault Mirage 2000," and "Sukhoi SU-30M," in *Jane's All the Worlds Aircraft 2002-2003*, ed. Paul Jackson (Coulson, UK: Jane's Information Group, 2002), 114-118, 405-406.

⁵⁸ Mark Farrer, "India Moving to Dominate Indian Ocean," *Asia-Pacific Defense Reporter* (June 2002), 35.

⁵⁹ P.R. Chari, "India's Slow-Motion Nuclear Deployment," in *Proliferation Brief*, 7 September 2000, at <<http://www/ceip.org/files/nonprolif/templates/Publications.asp?p=8&PublicationID=437>>.

⁶⁰ Estimates on the number of Prithvi 1 manufactured varies, see "Prithvi (SS-150/-250/-350)(P-1/P-2/P-3) and Dhanush," in *Jane's Strategic Weapon Systems*, no. 37, ed. Duncan Lennox (Coulson, UK: Jane's Information Group, 2002), 83-84

⁶¹ Jane's, "Army, India"; and Jane's, "Prithvi (SS-150/-250/-350)(P-1/P-2/P-3) and Dhanush."

⁶² Anthony H. Cordesman, *Weapons of Mass Destruction in India and Pakistan* (Washington, D.C.: Center for Strategic and International Studies, 23 January 2001), 5; and "India's Nuclear Forces, 2002," in *Bulletin of the Atomic Scientists*, 28 August 2002, at <<http://www.thebulletin.org/issues/nukenotes/ma02nukenote.html>>.

greater range of the Prithvi 2 makes it a more likely candidate for a nuclear delivery system compared to the Prithvi 1, but is still handicapped by short range. A one-stage solid fuel version of the Agni 1 (MRBM) achieved a range of 700 km in 2002, but may have a range of 700-900 km. This version of the Agni can reach all of Pakistan, while the hybrid solid-liquid versions have a much longer range, about 2,500 to 3,000 km. The longer range Agni 2 cannot reach Beijing or other major cities in northwest China.⁶³ India may have fully tested simulated nuclear weapons in the Agni 2 missile, and as many as five to six missiles plus support equipment may be available for use. Indian authorities have stated that the Agni is fully operational and deployed.⁶⁴ As longer-range ballistic missiles become operational they may replace aircraft as the prime delivery system for nuclear weapons.

Pakistan has several types of aircraft, including the Mirage III and F-16, that are capable of being used for a nuclear strike.⁶⁵ However, these aircraft have limited ranges and are vulnerable to India's air defense systems, making them a less reliable nuclear delivery system than ballistic missiles. Pakistan is thought to rely upon ballistic missiles as the preferred nuclear delivery system, but air delivery should not be ruled out.⁶⁶

Pakistan has developed solid and liquid-fueled missile that are capable of delivering nuclear weapons (see Table 4).⁶⁷ Pakistan has been very aggressive in developing ballistic missiles, gaining the Hatf 3/M-11 SRBM from China, and several longer-range missiles, including the liquid-fueled Hatf 5/Ghauri, a North Korean No-Dong derivative, and the Hatf 4/ Shaheen 1, and the Hatf 6/Shahen 2.⁶⁸ The Hatf 3 has

⁶³ Alex Wagner, "India Test Short-Range Agni Ballistic Missile," in *Arms Control Today*, March 2002, at <http://www.idsa.org/agni-1-250102.htm>; "Agni I/II/III," in *Jane's Strategic Weapon Systems*, no 37, ed. Duncan Lennox (Coulson, UK: Jane's Information Group, 2002), 80-82; and K. Santhanam, "Agni-1 and National Security," 25 January 2002, at <http://idsa-india.org/agni-1250202.htm>.

⁶⁴ Chari, "India's Slow-Motion Nuclear Deployment"; Andrew C. Winner and Toshi Yoshihara, *Nuclear Stability in South Asia* (The Institute for Foreign Policy Analysis, spring 2002), 37 at <http://www.ifpa.org/pdfs/nssa.pdf>; and Rodney W. Jones, *Minimum Nuclear Deterrence Postures in South Asia: An Overview* (Defense Threat Reduction Agency Advanced Systems and Concepts Office, 1 October 2001), 17-21, at http://www.dtra.mil/about/organization/south_asia.pdf.

⁶⁵ "Lockheed Martin F-16 Fighting Falcon," in *Jane's All the Worlds Aircraft 2002-2003*, ed. Paul Jackson (Coulson, UK: Jane's Information Group, 2002), 642-651.

⁶⁶ Winner and Toshihara, *Nuclear Stability in South Asia*, 41.

⁶⁷ Koch, *India, Pakistan: Nuclear Arms Race Off to a Slow Start*, 3.

⁶⁸ Tellis, *India's Emerging Nuclear Posture*, 46-50.

a 290 km range with a 500 kg warhead, the Hatf 4 has a range of 6-700 km with a 500 kg warhead, and the Hatf 5 has a range of up to 1,500 km with a 760 kg warhead.⁶⁹ There are about 30 Hatf 3/M-11 missiles that may be stored in a facility close to Lahore at Sargodha, and could strike India with very little warning. Pakistan continues to develop the Hatf 6, a longer-range missile. Pakistan also may have as many as 12 Hatf 5/Ghauri missiles.⁷⁰ Pakistan's emphasis on ballistic missiles has probably allowed it to gain a better operational capability with its missiles than India has with theirs.

Once again there is a degree of asymmetry in the strategic force structure of India and Pakistan. India has a distinct advantage in the capability to deliver nuclear weapons via aircraft, while Pakistan may have an advantage in the quantity of nuclear-capable ballistic missiles. The numbers of advanced nuclear capable aircraft and the ability to widely disperse them gives India an assured retaliatory capability, while Pakistan's limited number of aircraft and bases may not. However, Pakistan's solid-fueled missiles enjoy a smaller signature on the ground compared to India's liquid-fueled missiles due to a reduced support infrastructure, but the short-range solid-fuel version of the Agni-1 will remedy this when operational. Pakistan's missiles also have the ability to move and fire quickly, making them very survivable. India and Pakistan both have very limited response time due to the proximity of strategic systems to the targets.

Table 4. India and Pakistan – Ballistic Missiles⁷¹

Country	Missile	Range	Status
India	Prithvi 1 (SS-150)	150 km	Army version, in service
	Prithvi 2 (SS-250)	250 km	Air Force version, tested, in development
	Prithvi 3 (Dhanush)	350 km	Navy version, failed test in 2000
	Agni 1	700-900 km	Tested 25 January 2002, in development
	Agni 2	2,000-3,000 km	Tested in 1999 and 2001, in development
	Agni 3	3,500-4,000 km	In early development
Pakistan	Hatf 1	80 km	In service since mid-1990s
	Hatf 2 (Abdali)	180 km	Tested May 2002, in production
	Hatf 3 (Ghaznavi)	290 km	M-11, tested May 2002, in service
	Hatf 4 (Shaheen 1)	600-700 km	Tested October 2002, in service
	Hatf 5 (Ghauri)	1,500 km	No Dong, tested in May 2002, in service
	Hatf 6 (Shaheen 2)	2,000-2,500 km	Not yet tested, in development

⁶⁹ "Hatf 3," "Hatf 4," "Hatf 5," and Hatf 6," in *Jane's Strategic Weapons Systems*, no. 37, ed. Duncan Lennox (Coulson, UK: Jane's Information Group, 2002), 124-130.

⁷⁰ Jones, *Minimum Nuclear Deterrence Postures in South Asia*, 12; and "Pakistan's Nuclear Forces, 2001," in *Bulletin of the Atomic Scientists*, 6 July 2002, at <<http://www.thebulletin.org/issues/nukenotes/jf02.nukenote.html>>.

⁷¹ After Lavoy, "Fighting Terrorism and Avoiding War in South Asia."

D. NUCLEAR DOCTRINE

The final factor to consider in the potential interplay of conventional and strategic forces in South Asia are India and Pakistan's nuclear doctrines. Nuclear doctrine defines the role that strategic weapons play, particularly how and under what circumstances these weapons will be used. Once again we must deal with a lack of transparency since both India and Pakistan have cloaked their nuclear doctrines in secrecy. However, public statements by senior officials provide sufficient details to make an informed analysis.

1. India's Nuclear Doctrine

The National Security Advisory Board produced India's draft nuclear doctrine in August 1999. The board represented a cross section of India's military, political, and scientific community. The draft doctrine is based upon a retaliatory, no-first-use policy with the goal of deterring nuclear attacks, although other reasons to use nuclear weapons may not have been ruled out completely. India may not have thought through other contingencies, such as Pakistan using a nuclear weapon on its own territory in response to an Indian invasion. The doctrine is based on minimum credible deterrence. This doctrine envisions the following cornerstones: survivability, robust command and control, effective intelligence and early warning capability, planning and training, and finally the will to employ these weapons should deterrence fail. The government refused to officially endorse this draft proposal, leaving India's nuclear doctrine in an ambiguous status.⁷²

India's views on nuclear weapons are much different than Pakistan's, and may be designed for political utility, as well as for deterrence value.⁷³ Targeting philosophy is not specifically spelled out in the draft nuclear doctrine, but there is a theme of punitive response that would seem to imply a counter-value strategy. Pakistan's major cities and

⁷² National Security Advisory Board on Nuclear Doctrine, *India's Draft Nuclear Doctrine* (17 August 1999), at < http://www.indianembassy.org/policy/CTBT/nuclear_doctrine_aug_17_1999.html>; Waheguru Pal Singh Sidhu, "India's Nuclear Use Doctrine," in *Planning the Unthinkable: How New Powers Will Use Nuclear, Biological, and Chemical Weapons*, ed. Peter R. Lavoy, Scott D. Sagan, and James J. Wirtz (Ithaca: Cornell University Press, 2000), 128; and Lt Gen. Pran Pahwa, *Command and Control of Indian Nuclear Forces* (New Delhi: United Service Institution of India, 2002), 47-48.

⁷³ Sidhu, "India's Nuclear Use Doctrine," 146.

industrial areas could be readily targeted and attacked with either aircraft or ballistic missiles.⁷⁴ Alternatively, India could target Pakistan's military or nuclear facilities in a counter-force attack given the short ranges and knowledge of Pakistan's military capabilities.⁷⁵ The survivability of India's nuclear forces may be ensured through secrecy and dispersal, including separating weapons from delivery systems. India's nuclear doctrine may be in a state of transition, since it does mention of a nuclear triad and command and control functions that may not currently exist.⁷⁶

2. Pakistan's Nuclear Doctrine

Pakistan has not publicly announced an official nuclear doctrine. However, there have been public statements by senior officials that may indicate what that policy is. Major General Khalid Kidwai, chief of Pakistan's Strategic Plan Division, provided a great deal of information on Pakistan's doctrine in an interview conducted in late 2000. Kidwai left no doubt that Pakistan's nuclear doctrine was directed at India. He claimed that four different scenarios could threaten Pakistan's existence as a state and cause the use of nuclear weapons. All four scenarios are in response to India's actions and include the loss of a large part of Pakistan's territory, destruction of a large part of Pakistan's military, economic strangulation, or other attempts to politically de-stabilize Pakistan.⁷⁷

Pakistan could use nuclear weapons if faced with a major military defeat or the occupation or threatened occupation of vital areas.⁷⁸ These circumstances are in agreement with three general themes that may outline what Pakistan believes are the "red-line" or point where it must use nuclear weapons. The first theme may be to deter a large-scale conventional war with India, particularly an Indian invasion with a goal of splitting Pakistan in half. The use of nuclear weapons in this scenario can be thought of

⁷⁴ National Security Advisory Board on Nuclear Doctrine, *India's Draft Nuclear Doctrine*, 17 August 1999

⁷⁵ Jones, *Minimum Nuclear Deterrence Postures in South Asia*, 29-30.

⁷⁶ Winner and Toshihara, *Nuclear Stability in South Asia*, 33.

⁷⁷ Paolo Cotta-Ramusino and Maurizio Martellini, *Nuclear Safety, Nuclear Stability, and Nuclear Strategy in Pakistan: A concise report of a visit by Landau Network-Centro Volta* (Landau Network, 21 January 2002), 4, at <<http://lxmi.mi.infn.it/~landnet/Doc/pakistan.pdf>>.

⁷⁸ Kampani, *Placing the Indo-Pakistan Standoff in Perspective*, 15.

as ensuring national survival. The second contingency could be to deter nuclear threats or nuclear coercion by India, and may include pre-emption of a nuclear attack by India. Finally, Pakistan could resort to the use of its nuclear weapons to deter India from using its stockpile of chemical weapons as declared under the Chemical Weapons Convention, although this does not resonate across other scenarios for the use of nuclear weapons.⁷⁹ India has committed to destroying its chemical weapon stocks.

Pakistan may have a simple counter-value nuclear targeting doctrine to deter India by holding major population and economic centers at risk. Pakistan has developed longer-range ballistic missiles capable of reaching many of India's major cities. An alternative to targeting India's cities would be to target India's military forces, particularly large mechanized formations that may be threatening Pakistan. Either missiles or aircraft would be capable of attacking major military formations. Pakistan could use one or two nuclear weapons as a warning shot, by detonating the weapons on its own soil as a sign that further escalation would be severely punished.⁸⁰

Pakistan's nuclear forces are an integral part of Pakistan's defensive strategy, and are viewed as the ultimate guarantee of national survival.⁸¹ This doctrine does not include a no-first-use clause, leaving Pakistan with a de facto first-use option to offset India's conventional superiority, somewhat akin to NATO doctrine during the Cold War. A no-first-use pledge could undermine the credibility of Pakistan's nuclear deterrence against a conventional attack by India.⁸²

⁷⁹ Zafar Iqbal Cheema, "Pakistan's Nuclear Use Doctrine and Command and Control," in *Planning the Unthinkable: How New Powers Will Use Nuclear, Biological, and Chemical Weapons*, ed. Peter R. Lavoy, Scott D. Sagan, and James J. Wirtz (Ithaca: Cornell University Press, 2000), 176.

⁸⁰ Jones, *Pakistan's Nuclear Posture*, 20; and Winner and Toshihara, *Nuclear Stability in South Asia*, 39.

⁸¹ Koch, *India, Pakistan: Nuclear Arms Race Off to a Slow Start*, 2-4; and Clay P. Bowen and Daniel Wolven, "Command and Control Challenges in South Asia," *The Nonproliferation Review* (spring/summer 1999), 26.

⁸² Cheema, "Pakistan's Nuclear Use Doctrine and Command and Control," 177.

E. CONCLUSION

This chapter describes the military asymmetries that currently exist in South Asia. India has achieved numerical and qualitative superiority in many categories, particularly in mechanized ground forces and in attack aircraft. India is also improving its conventional military forces at a rate that Pakistan cannot match due to a disparity of resources. Both India and Pakistan have relatively small nuclear arsenals. Pakistan has attempted to offset India's conventional advantage by building a nuclear force, while India's nuclear deterrence is designed primarily to deter nuclear attack. Pakistan has put most of its emphasis on ballistic missile delivery systems, and probably has achieved a good operational capability, while it continues to fall behind in nuclear delivery aircraft. India had the initial lead in missile technology, but failed to follow through, causing it to lose its initial advantage. India currently is putting greater emphasis on its missile program, and the number and quality of nuclear capable aircraft continues to grow. This asymmetry of means is reinforced by asymmetry of methods, especially in nuclear doctrine. India has a retaliatory doctrine, while Pakistan reserves a first-use option to deter India's conventional superiority. These factors have a tremendous influence on the potential for inadvertent escalation.

III. SURVIVABILITY AT RISK

A. INTRODUCTION

Can conventional warfare threaten the survival of strategic forces (that is, nuclear weapons and delivery systems)? Conventional warfare in this paper generally refers to larger scale conventional operations, not a more limited conflict such as that fought in Kargil in 1999. Large-scale conventional operations could potentially degrade the survivability of the opponent's nuclear option by coming into contact with the nuclear forces of an adversary and substantially affecting the victim's confidence in its future ability to operate those forces in ways that he had counted upon.⁸³ As Barry Posen observed, this possibility could be very problematic for "small or medium-sized nuclear powers, since they will have the most difficult time building nuclear forces that can survive."⁸⁴ This situation applies to the strategic relationship between India and Pakistan.

A secure second-strike capability is an essential part of deterrence. This means that the strategic force must be able to survive to retaliate if attacked first.⁸⁵ Traditionally, this has meant that strategic forces must be able to survive a nuclear attack. This led both the United States and the Soviet Union to develop nuclear triads made up of long-range bombers, land-based missiles, and submarine-based missiles. Posen's study demonstrated that NATO or Warsaw Pact conventional military operations could threaten the survival of strategic forces and consequently undermine stable nuclear deterrence. Can the same be said of India and Pakistan?

This chapter examines how conventional forces can threaten the survivability of strategic forces and potentially cause an inadvertent escalation to nuclear war. It begins by examining the question of strategic depth, one of the critical factors that dictate much of the military force structure and strategy in South Asia. Next, scenarios for ground and air campaigns are studied, with both India and Pakistan initiating military action. This

⁸³ Posen, *Inadvertent Escalation*, 2.

⁸⁴ *Ibid.*, 2.

⁸⁵ Carranza, "An Impossible Game," 16.

technique brings to light some of the shortfalls of equipment, doctrine, and strategy that could lead conventional forces to place strategic forces at risk. Pakistan's lack of strategic depth could lead to Indian conventional ground or air forces coming into contact with Pakistan's strategic nuclear forces. This could cause Pakistan to use nuclear weapons, since the loss of this asset would undermine its military strategy. The converse is probably not true; India's greater strategic depth and superior military capabilities would prevent Pakistan's forces from seriously threatening India's strategic forces with conventional forces.

B. SURVIVABILITY OF STRATEGIC FORCES

India and Pakistan rely primarily on secrecy and dispersal to ensure the survivability of their relatively small strategic nuclear forces. Strategic depth, or the lack of it, plays a major role in the potential for ground and air operations to threaten the survival of the strategic weapon systems and cause inadvertent escalation.

1. India's Strategic Depth

India has all of the advantages of strategic depth. This allows India to disperse strategic forces widely among numerous sites, installations, and airfields. India may still rely on aircraft for nuclear delivery, but this may be a workable solution for a secure second-strike capability due to India's comparatively large number of aircraft and units capable of performing nuclear delivery. India has been developing several types of missiles to deliver a nuclear warhead. The Prithvi may not have a nuclear delivery role due to its short range. There may be as few as six Agni missiles in India's arsenal, perhaps requiring them to be saved for a potential threat from China. The Agni's longer-range combined with India's strategic depth would probably make them invulnerable to Pakistani attack. Another factor that enhances the survivability of India's nuclear deterrent is the doctrinal separation of the nuclear weapons from the delivery systems, and the civilian control of the weapons themselves, as discussed in Chapter 2. Unlike aircraft, missile systems must rely upon what may be a limited number of ancillary support equipment, such as transporter erector launchers (TEL). The Prithvi and the

current two-stage version of the Agni are liquid-fueled, requiring intense logistical support to operate, and have a corresponding large signature. Strategic depth can compensate in large measure for this shortcoming (see Figure 1).

Figure 1. India and Pakistan⁸⁶



2. Pakistan's Lack of Strategic Depth

Pakistan's lack of strategic depth means many of its airfields and strategic assets are close to India. There are far fewer Pakistani aircraft and units able to perform the nuclear delivery role compared to India. However, Pakistan has offset this disadvantage by vigorously pursuing ballistic missiles. Several types of road-mobile missiles are available for use. The Hatf 3 and -4 use solid-fuel, with only the Ghauri using liquid-fuel, which makes for a very reliable delivery option. Solid-fueled missiles have a much smaller logistical support train and corresponding signature compared to liquid-fueled rockets, representing a major advance in military technology. The small signature of these systems may play a major role in their survivability. These missile systems must rely upon what may be a limited number of ancillary support equipment, like TELS.

⁸⁶ From "South Asia Map," at <http://www.travelersdigest.com/south_asia_map.htm>, downloaded 2 December 2002.

C. CONVENTIONAL WARFIGHTING IN A NUCLEAR ENVIRONMENT

Could the conventional and strategic forces of India and Pakistan interact in such a manner that inadvertent nuclear escalation could result? The force structure and doctrine of both nations reflect an aggressive, offensively oriented mindset, whether termed as offensive-defensive doctrine or riposte doctrine. Historical precedents show that both India and Pakistan are willing to engage in offensive military actions, either in an initial attack or a strong counterattack. India and Pakistan have invested in armored and mechanized forces with a good offensive capability, and dual-purpose fighter-bombers are very complementary to this strategy. Offensive actions consisted primarily of air and ground forces in previous military engagements, and will be the focus of this section.

1. Historical Example

The last two major wars fought in South Asia were in 1965 and 1971, and can serve as starting points for the study of large-scale conventional warfare on the sub-continent. The dispute over the Rann of Kutch, a marshy area located on the southern border between India and Pakistan, erupted into battle in April 1965. The Pakistan Army enjoyed the advantages of an established road network on its side of the border and quickly routed Indian outposts in the region with a well-coordinated attack. Pakistan became emboldened by its relatively easy success and by mid-August Indian and Pakistan regular Army forces were skirmishing in the border regions between West Pakistan and India. The Pakistani plan to link military forces with the guerrillas in Kashmir failed when local officials apprehended most of the guerrillas and turned them over to the Indian Army.⁸⁷

The Indian Army gained the initiative in late August 1965 when it crossed the border into Pakistan, which in turn caused the Pakistan Army to retaliate with its own offensive on 1 September. The PAF launched a series of relatively unsuccessful air attacks on Indian military bases and installation. Airpower was widely used by both

⁸⁷ Gowher Rizvi, "India, Pakistan, and the Kashmir Problem, 1947-1972," in *Perspectives on Kashmir: The Roots of Conflict in South Asia*, ed. Raju G.C. Thomas (Boulder: Westview Press, 1992), 69-70.

sides in support of ground operations, and the Pakistani Army was able to penetrate toward Akhnur. The Indian Army mounted a major counteroffensive through the Punjab towards Lahore on 6 September to remove pressure from other sectors, stopping only at the outskirts of the city. A simultaneous Indian thrust on a different avenue in the vicinity of the Pakistani city of Sialkot resulted in the largest clash of forces during the war with approximately 400-600 tanks joined in battle. The development of a military stalemate on the ground caused the conflict ground to a halt on 17 September. Total losses were much higher than in the 1947 war with nearly 7,000 total deaths, and approximately 100 aircraft and 400 tanks lost by the participants. The Line of Control (LOC) that now divides Indian-held Kashmir from Pakistani-held Kashmir became an un-welcomed fact of life, but little territory was lost during the war.⁸⁸

The next major clash between India and Pakistan occurred in December 1971. The cause of this war was complex. An internal civil war was being waged in East Pakistan between the Muslim Bengalis and the elite rulers of Pakistan who were overwhelmingly West Pakistani. Another important factor was Pakistan's assessment that the window of opportunity to confront India militarily was rapidly shrinking due to India's growing military and economic strength.⁸⁹ Pakistan launched a surprise air attack on Indian military bases in the Northwest Territories on 3 December 1971 in coordination with a ground attack into Kashmir, Punjab, and Rajasthan. India retaliated with its own air attacks and a counteroffensive, including naval bombardment of the port city of Karachi. There was heavy fighting in the border regions of India and West Pakistan, including a major tank battle in the Sialkot-Shakargarh area, and another northwest of the city of Jaisalmer. The IAF played a major role in this sector, mounting some 4,000 sorties, allowing the Indian Army to concentrate on their eastern front.⁹⁰

The Indian Army invaded Eastern Pakistan, which became the site of the heaviest fighting. The Pakistani Army assumed a defensive posture, destroying bridges in this mostly delta region and fortifying strong points. The IAF succeeded in destroying

⁸⁸ Sumit Ganguly, *The Origins of War in South Asia: Indo-Pakistani Conflicts Since 1947* (Boulder: Westview Press, 1994), 47-48.

⁸⁹ Ibid, 81, 87-89; and Ganguly, *Conflict Unending, India-Pakistan Tensions Since 1947*, 52-62.

⁹⁰ Ibid, 81-82.

Pakistan's limited air assets in the area in the initial air raids, and the Navy effectively blockaded the entirety of East Pakistan. The Indian Army was able to mount a sustained offensive by crossing the rivers using a combination of local shipping and helicopters. Indian forces continued to advance on Dacca, the regional capital, and reached the outskirts of the city by 16 December.⁹¹ Approximately 93,000 Pakistani troops surrendered in East Pakistan, which subsequently became Bangladesh. This eastern offensive was very successful and a ceasefire was brokered on 17 December. Pakistani losses were much heavier than those of India, with 200 tanks, 75 aircraft, 1 submarine and nearly 9,000 battlefield deaths compared to the loss of 80 tanks, 45 aircraft, 1 frigate, and 2,500 casualties by India.⁹²

These previous campaigns show that both India and Pakistan have the capacity for offensive ground and air actions. Current force structure and doctrine demonstrate that they retain this capacity. How could this play out on the subcontinent in the event of a large-scale conventional conflict?

2. Asymmetric Conventional Strategies

India and Pakistan have asymmetric conventional military strategies. India has recently developed a doctrine of limited war. This plan is designed to "punish" Pakistan without crossing Pakistan's nuclear "red-line."⁹³ Pakistan has a riposte strategy that calls for absorbing an initial attack and counter-attacking along a different line of approach.

India's limited war strategy seeks to undermine what it believes is Pakistan's use of the stability-instability paradox. The stability-instability paradox is defined as the use of nuclear deterrence to support conventional military aggression.⁹⁴ Indian Minister of Defense Fernandes and COAS General Malik announced in January 2000 that India

⁹¹ Ibid, 82-83.

⁹² Ganguly, *Conflict Unending*, 70; and Ganguly, *The Origins of War in South Asia*, 83-84.

⁹³ General V.P. Malik briefing, "Terrorism and Limited War with Kargil Backdrop," presented at National Defense University; Gaurav Kampani, "India's Compellance Strategy: Calling Pakistan's Nuclear Bluff over Kashmir" (Monterey, Calif.: Center for Nonproliferation Studies, March 2002), at <<http://cns.miis.edu/pubs/week/020610.htm>>; and Kampani, *Placing the Indo-Pakistani Standoff in Perspective*, 13-15; and "India Attacks Nuclear Blackmail," in *BBC News* (18 June 2002) at <http://news.bbc.co.uk/hi/english/world/south_asia/newsid_2051000/2051898.stm>.

⁹⁴ Raghavan, "Limited War and Nuclear Escalation in South Asia," 83.

could fight a conventional campaign against Pakistan, despite Pakistan's possession of nuclear weapons.⁹⁵ India's limited war doctrine recognizes the link between deterrence and limited war and is based upon the concept that waging a limited conventional war is the most important part of deterrence. Limited war primarily entails controlling escalation by limiting the duration of military actions, scope (depth) of actions, and/or force levels.⁹⁶

This limited war strategy gives India four basic options. The first option is to attack across the international boundary or LOC, but to keep the objectives limited. The second option is to attack at selected points along the LOC, presenting Pakistan with the option of escalating by responding with a riposte. The third option is to capture and hold a critical area along the LOC. The final option is to carry out surgical strikes across the border, then return.⁹⁷

The 1999 Kargil Crisis is yet another example of the Indian strategy of limited war. Indian forces responded to infiltration in the Kargil area of the LOC under orders not to cross the international border. However, Indian military forces operating on their side of the border were heavily reinforced in terms of numbers of troops, equipment, and amount of firepower used. This allowed India to gain the upper hand in the local area without causing escalation to a larger scale conflict.⁹⁸

3. Ground Campaign

The Indian armed forces completely mobilized in late 2001 following the terrorist attack on the Indian Parliament. Pakistan's *Defense Journal* provided a very detailed account of India's mobilization and possible strategies. Most of India's mechanized might was mobilized in positions from which they could strike Pakistan, with one strike corps threatening the southern part of Azad Kashmir, two in Punjab, and one oriented towards Sindh. The majority of the armored and RAPID units were positioned in

⁹⁵ Ibid, 84.

⁹⁶ Malik, "Terrorism and Limited War with Kargil Backdrop," slides 34-39.

⁹⁷ Maj. Gen. Ashok Krishna, "Deployment of India's Armed Forces along the International Border (IB), the Line of Control (LoC) and at Sea," 8 July 2002, at <http://www.ipcs.org/issues/700/788-mi-krishna.html>.

⁹⁸ Malik, "Terrorism and Limited War with Kargil Backdrop," slides 59-67.

Rajasthan where they could attack along the Jaisalmer-Rahimyar Khan or Barmer-Mirpurkhas routes.⁹⁹

There are historical precedents for this positioning and strategy. Indian offensive forces penetrated as far as Lahore during the 1965 war, and a supporting offensive threatened Sialkot that had the potential to cut Pakistan in half. India may choose not to mount a full-scale attack for fear of crossing Pakistan's "red-line" and provoking a nuclear response. This may prompt India to adopt a smaller-scale ground offensive with much more limited goals. Indian perception of Pakistan's "red-lines" appear to recognize that total military defeat could cause nuclear retaliation. However, recent military exercises continue to practice similar tactics to those used during the 1965 war (i.e., a full-scale mechanized thrust). Operation Divine Power in 1998 and Total Victory in 2001 put Indian mechanized forces into the Rajasthan region where they could rapidly attack into Pakistan.¹⁰⁰

An Indian attack akin to that launched in the 1965 war could penetrate deeply toward Lahore, which is in Pakistan's 4 and 5 Corps sectors (see Figure 2). If this attack is a diversion, then the main attack could be aimed further south, close to Rahim Yar Khan. This region is little more than 70 kilometers wide, and an attack there could cut Pakistan's vital north south supply routes again threatening to cut Pakistan in half at its narrow waist.¹⁰¹ This strategy gives India a numerical advantage in sector. India has an overall advantage in number of mechanized units and quality of equipment. India's larger number of tanks and infantry fighting vehicles may give it an edge in mobility and firepower. India has also worked hard to incorporate air assets in any offensive. Indian air superiority would provide India with a tremendous advantage on the ground, and could include the use of advanced ground attack aircraft, such as the Mirage 2000 or SU-30.

⁹⁹ Ikram Sehgal, "India's War Plan," *Defense Journal* (January 2002) at <<http://www.defensejournal.com/2002/january/war.htm>>.

¹⁰⁰ Rodney Jones, "India Exercises Military Muscle," in *Friday Times* (8 July 2001), at <<http://www.thefridaytimes.com/news6.htm>>.

¹⁰¹ Rodney Jones, *Pakistan's Nuclear Posture*, 16-17; and Jane's, "Army, Pakistan".

Figure 2. Possible Indian Ground Attack¹⁰²

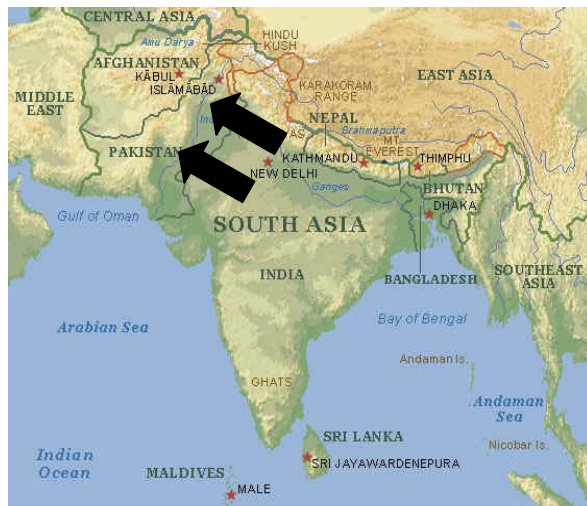

Pakistan most likely would deploy its strategic forces if facing a full-scale conventional war with India. Strategic weapons deployment was documented during the 1986-87 Brasstacks Crisis, 1990 Kashmir Crisis, and the 1999 Kargil Crisis. Air-deliverable nuclear weapons were reportedly readied and placed on aircraft during these crises. Reports of SRBM deployments surfaced in the 1999 Kargil Crisis, and in the December 2001 to October 2002 crisis.¹⁰³ Pakistan might use nuclear weapons if facing an Indian invasion with a goal of splitting Pakistan in half, as called for by the nuclear doctrine. The use of nuclear weapons in this scenario could be construed as ensuring national survival, and to use them purposefully would be deliberate escalation.

However, escalation also could occur inadvertently. A rapid advance by the Indian army could put the Hatf 3/M-11 missiles at risk if these missiles are stationed at Sargodha. The Hatf 3/M-11 may have to remain fairly far forward to range strategic targets in India because of their short range, placing these strategic systems at risk to a deep penetration by ground forces. The same is true of many of Pakistan's airbases. The longer-range systems developed recently, such as the Ghauri and Hatf 6, would probably

¹⁰² Modified by author from "South Asia Map."

¹⁰³ There are numerous accounts of the deployment of nuclear-armed strategic forces of India and Pakistan beginning with the 1987 Brasstacks Exercise. See Cheema, "Pakistan's Nuclear Use Doctrine and Command and Control," 169-171; Lee Feinstein, "Avoiding Another Close Call in South Asia", in *Arms Control Today* (July/August 2002); Devin T. Haggerty, *The Consequences of Nuclear Proliferation: Lessons from South Asia*, (Cambridge, Mass: MIT Press, 1998), 102-104; and the International Institute for Strategic Studies *Strategic Survey 2002/2001* (London: Oxford University Press, 2001), 221-213.

be invulnerable to ground attack. Any deep penetration could threaten to overrun or destroy nuclear weapons and delivery systems since Pakistan places great emphasis on nuclear deterrence to offset India's conventional power. This could potentially prompt a use-it-or-lose-it mentality that leads to the use of nuclear weapons. Pakistan could also mistake a major Indian military offensive for an attempt to destroy the country even if the attack was more limited and only intended as a demonstration of Indian resolve. All of these situations serve as examples of potential inadvertent escalation. A more limited Indian attack in terms of duration, depth, or force levels could be handled without resorting to Pakistani use of nuclear weapons. However, a strong Pakistani conventional response to a limited attack could result in escalation to a general war.

The Pakistan Army has completely mobilized in more recent crises.¹⁰⁴ Mobilization gives Pakistan three conventional military response options in a conventional war with India. First, Pakistan could take a defensive posture in the hope that the war would remain limited, or that the international community would step in and prevent further escalation. Second, Pakistan could remain primarily defensive, but then counter-attack either in a limited fashion, or cross the international border and put pressure on a different front using the riposte doctrine. Third, Pakistan could choose to mount a pre-emptive attack. Most of Pakistan's offensive ground capability is represented in the two strike corps that are generally pulled back from the border where they are positioned to counterattack, or riposte, against an Indian offensive.¹⁰⁵

The Pakistan Army attacked India in 1965 and 1971 using armored and mechanized offensive operations. Pakistan exercised the second option in 1965, with limited local counter-attacks and a major attack towards Beas that put pressure on a different front and threatened to cut off Amritsar and Indian forces facing Pakistan's Lahore front. Pakistan was prepared to launch a strategic riposte in both 1984 and during the 1987 Brasstacks Crisis (see Figure 3). Pakistan launched a pre-emptive attack in Punjab in 1971, representing the third option. These historical cases demonstrate that Pakistan has a tendency to take the offensive in the belief that such tactics are stronger

¹⁰⁴ Sehgal, "India's War Plan."

¹⁰⁵ See Anthony H. Cordesman, "In India, Pakistan Face-Off, An Uneven Military Match," in *San Diego Union-Tribune* (9 June 2002). For a somewhat different assessment of Pakistan's military options, see Jane's, "Army, Pakistan."

than defensive tactics, and that a weaker opponent with the initiative can defeat a numerically superior enemy, as shown throughout the Arab-Israeli wars. Pakistan's strike corps could attack across the border and advance towards New Delhi along routes in Punjab and the southern desert, or it could mount an offensive to cut Kashmir off from the India, as they did during the 1965 India-Pakistan War by launching a pre-emptive thrust towards Akhnur aiming to cut off the strategic Akhnur Bridge.

Figure 3. Possible Pakistani Counter-attack¹⁰⁶

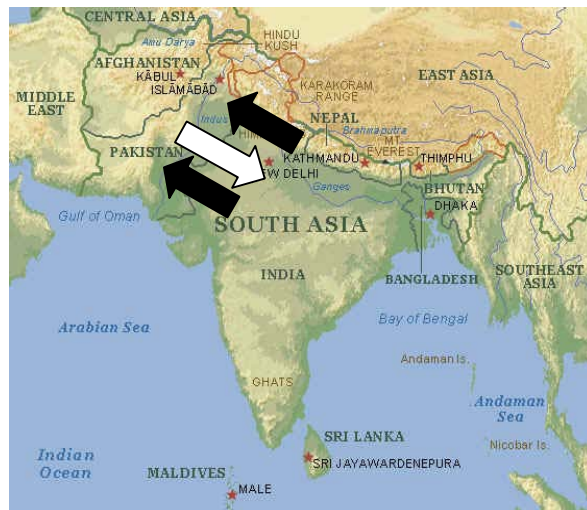

India enjoys a numerical advantage in ground forces and is roughly equivalent to Pakistan in the quality of men and equipment. Indian forces and defensive lines have been arrayed in such a way that probably would stop any Pakistani attack far short of the capital.¹⁰⁷ India may choose to deploy its strategic forces under the threat of full-scale conventional war. It is unlikely that a major Pakistan ground offensive would make contact with India's strategic forces, given India's strategic depth and the peacetime position of its strategic forces. Any such contact would be even more unlikely to undermine the central tenet of India's retaliatory-only posture. Any Indian escalation across the nuclear threshold in the context of a ground offensive by Pakistan would likely result from deliberate escalation, not inadvertent escalation. However, a major

¹⁰⁶ Modified by author from "South Asia Map."

¹⁰⁷ Cloughley, *A History of the Pakistan Army*, 341.

conventional Pakistani riposte would serve as a conventional escalation, with India responding in kind. Increased force levels could lead to a cycle of escalation, and then in turn lead to deliberate or inadvertent nuclear escalation.

Some commentators note that there seems to be a rough parity between the Indian and Pakistani armies despite the overall disparity in numbers. This view is based on several factors. First, despite their numerical advantage, India has to consider two military fronts, the other being China. Therefore, the entire armed might of India be able to be focused on Pakistan. Secondly, and perhaps most critical in this context, a near parity exists between the armies when one considers the armored and mechanized units that would be relied upon to make any offensive thrusts, or counterattacks. It is most likely that given this rough parity of forces, limited numbers of routes of advance, and years of training and preparation, that any conventional attacks in this region would result in a bloody draw, with no real advantage gained by either side.¹⁰⁸ The concentration of Indian forces on such a narrow front and the growing qualitative and quantitative superiority of Indian forces could undermine this parity if it exists today, and may completely disappear in the near future if the current trends continue.

4. Air Campaigns

India could launch deep air strikes or conventionally armed ballistic missiles against Pakistan as part of a general war strategy, or as surgical strikes as part of a limited response. Some of the attacks would be successful due to India's numerical superiority of strike aircraft and fighters and Pakistan's less developed network of air defenses. There are also sufficient numbers of Prithvi 1 and -2 missiles to be used in the conventional role to attack deep targets. These attacks could be in the form of pre-emptive attacks, or as interdiction to limit support for Pakistan ground forces.

Pakistan formed its Air Defense Command in 1975, and there are four subordinate headquarters. Pakistan has a comprehensive radar network incorporating a wide array of military sites and civilian air traffic control radars. Equipment is assorted,

¹⁰⁸ Brian Cloughley, "Pakistan's Army Still an Army," *Asia-Pacific Defense Reporter* (April/May 2000), 18.

and includes short-range, long-range, and low-level radars, giving Pakistan a good capability to detect aircraft. However, it has very limited time to respond since many important installations are very close to the Indian border. Pakistan's air defense capabilities consist of aircraft, SAMs, and air defense artillery. Pakistan uses the F-16, Mirage III, and Chinese F-7 fighters, which are all fairly capable in the air-to-air interceptor role.

Pakistan has very limited surface to air missile capability, consisting of six to eight squadrons of Crotale missiles, and one squadron of Chinese made SA-2s. However, there are large numbers of anti-aircraft guns, with possibly as many as forty-three separate units, nominally referred to as regiments, but with much less personnel and equipment.¹⁰⁹ While national air defense coverage is less than adequate, sensitive facilities may have adequate defensive coverage to make them difficult to attack. Pakistan does not have any type of defense against ballistic missiles and is unlikely to acquire them, since it deems them to be destabilizing.¹¹⁰ These advanced missile systems are also very expensive, and may be too much for an already strained defense budget.

Indian air and ballistic missile attacks have the potential to come into contact with Pakistan's strategic forces, particularly if Pakistan's forces have been mobilized and deployed. Indian air attacks could potentially threaten the survivability of Pakistan's strategic forces. Successful attacks upon Pakistan could lead to a use-it-or-lose-it mentality. Pakistan could escalate to the use of nuclear weapons under these circumstances for fear that they would lose this critical asset.

Pakistan could launch long-range air attacks on Indian airfields or logistical infrastructure similar to the events during the 1965 and 1971 wars, or even use conventionally armed ballistic missiles. Aircraft and longer-range ballistic missiles have sufficient range to hit many targets in India's western regions, where India may have

¹⁰⁹ Dr. Sanjay Badri-Maharaj, *Strategic Air Defenses in Nuclear South Asia*, 15 August 2002, at <<http://www.bharat-rakshak.com/IAF/Info/SAD.html>>.

¹¹⁰ Mutahir Ahmed, "Missile Defense in South Asia: A Pakistani Perspective," in *The Impact of U.S. Ballistic Missile Defenses on Southern Asia*, ed. Michael Krepon and Chris Gagne (Washington, D.C.: Henry L. Stimson Center, July 2002), 26.

strategic forces stationed. Such air attacks could be in the form of pre-emptive attacks, or as interdiction to limit support for Indian ground forces.

India has a much more robust air defense system than Pakistan. It has a nation-wide advanced air defense ground environment system linking military and civilian radars into a coordinated network. The first layer consists of mobile observation posts, which are small teams of observers equipped with binoculars and radios scattered around the border. The radar picket line is next, which is made up of several different radars linked into a cluster and tied into a reporting center. Finally, there are long-range surveillance radars based on a French design and produced in India for years, giving the air defenses the capability to detect aircraft out to 400 km. India also has local air defense zones to defend high value targets. This is in a three-layer array also, consisting of mobile observation posts, a line of air defense weapons with their associated radar control, and finally a line of low-level radars.¹¹¹

Most of India's interceptors are MiG aircraft, including the MiG-29, but dual-role aircraft such as the Mirage 2000 and SU-30s are available for defensive use. India also has thirty-eight squadrons of surface-to-air missiles. These are of mostly Soviet design, and include SA-6 and SA-8 systems.¹¹² India employs numerous radar directed 40mm anti-aircraft guns and man portable missiles for a last layer of defense of important facilities. India is currently building an anti-tactical missile (ABM) screen, consisting of Russian built S-300 (SA-10) and possibly the Indian designed and manufactured Akash missiles. The SA-10 has been successfully tested against Scud missiles, though the Akash has not demonstrated ABM capability yet. It is not clear when these systems will be operational.¹¹³ These missiles are considered to be capable of destroying short-range tactical ballistic missiles, potentially giving India the capability to defeat a limited number of shorter-range ballistic missiles in the not too distant future, perhaps protecting key installations.¹¹⁴ India has shown a great deal of interest in developing a missile

¹¹¹ Badri-Maharaj, *Strategic Air Defenses in Nuclear South Asia*.

¹¹² Jane's, "Army, India".

¹¹³ "SA-10/20 'Grumble' (S300, S-300 PMU, Buk/Favorit/5V55/48N6)," and "Akash" in *Jane's Strategic Weapons Systems*, no. 37, ed. Duncan Lennox (Coulson, UK: Jane's Information Group, 2002), 315-319 and 272-273.

¹¹⁴ Badri-Maharaj, *Strategic Air Defenses in Nuclear South Asia*.

defense, and supported the United States' withdrawal from the Anti-Ballistic Missile Treaty. While even the best missile defense system is incapable of defeating all missile attacks, it can limit damage, particularly if the attack itself is limited.¹¹⁵

Sufficient numbers of Pakistani aircraft or missiles could still penetrate India's defenses and come into contact with India's strategic arsenal. India probably has no real concerns that they would lose their strategic nuclear capability under these circumstances. India's greater strategic depth and redundancy of delivery systems serve to ensure that sufficient quantities of strategic systems would still survive. Additionally, India appears to have a retaliatory nuclear doctrine, and such contact would probably not lead to a nuclear response. Coupled with the advertised strong negative controls on nuclear weapons, there is little possibility of inadvertent escalation in this scenario.

D. CONCLUSION

Large-scale conventional warfare between India and Pakistan has the potential to threaten the survival of Pakistan's strategic nuclear forces. However, limited Indian attacks, such as a retaliatory strike on the ground or through the air, would not serve as a real threat to the strategic weapon systems.

The asymmetries of strategic depth and offensive military capability give India an advantage, and may lead to Indian large-scale conventional ground or air attack coming into contact with Pakistan's strategic nuclear forces. Pakistan's shorter-range Hatf 3/M-11 ballistic missiles must be stationed fairly far forward to range strategic targets in India, perhaps leaving them vulnerable to both air and ground attack. The same is true of Pakistan's forward airbases, which are within easy striking distance of the border. This is a very troubling scenario since Pakistan places great emphasis on its strategic nuclear forces to deter a large-scale conventional attack by India. The survival of Pakistan's strategic forces is critical to Pakistan, and a threat to them may prompt Pakistan to launch a nuclear attack while the strategic forces are still intact and capable of making a credible impression upon India.

¹¹⁵ Rajesh M. Basrur, "Missile Defense and South Asia: An Indian Perspective," in *The Impact of U.S. Ballistic Missile Defenses on Southern Asia*, ed. Michael Krepon and Chris Gagne (Washington, D.C.: Henry L. Stimson Center, July 2002), 10.

India's greater strategic depth gives it the ability to widely disperse its strategic nuclear forces to areas beyond the normal range of Pakistani ground and air operations. Longer-range platforms, such as the SU-30 and the Agni missile series, further decrease Indian vulnerability. When combined with India's presumed retaliatory only nuclear doctrine, this would seem to preclude inadvertent escalation on India's part.

IV. COMMAND AND CONTROL THREATENED

A. INTRODUCTION

Can conventional warfare threaten the command and control of the strategic forces? The second of Posen's conditions considers the effects of conventional attacks that could degrade the adversary's use of his nuclear forces in the time, place, and method of his choosing, forcing major changes in war fighting strategy.¹¹⁶ This could present a major problem if one nation depends on a limited nuclear strike to offset an opponent's conventional superiority on the battlefield. Of primary concern in this scenario is the loss of the capability to maintain adequate command and control of the nuclear weapons systems.

There are two general types of nuclear command and control –positive and negative– which closely correlate to the always/never problem. Positive control measures can be described as the “authorization and coordination of attack preparations or actual strikes,” and negative control as those measures that prevent “accidental or unauthorized launch of nuclear weapons.”¹¹⁷ Negative control can include such features as command disable functions, permissive action links (PAL), separation of warhead from the delivery system, personnel reliability program, and security functions. Positive control can be thought of as those measures that ensure that the nuclear weapons work as intended when needed. Included in this category are redundant command and control systems, the reliability of the delivery systems and nuclear weapons themselves, and perhaps pre-delegation of launch authority. There tends to be an inherent trade-off between these factors, commonly called the always/never problem, with improvements to one side of the equation leading to some loss on the other side.¹¹⁸ There may be a tendency towards negative control, or “never”, during peacetime. This may move toward positive, or “always”, under crisis or wartime conditions. As with the always/never

¹¹⁶ Posen, *Inadvertent Escalation*, 2.

¹¹⁷ Bruce G. Blair, *Strategic Command and Control: Redefining the Nuclear Threat* (Washington, D.C.: Brookings Institution, 1985), 68-69.

¹¹⁸ For a discussion of the always/never problem concerning the positive and negative controls of nuclear weapons see Peter D. Feaver, *Guarding the Guardians: Civilian Control of Nuclear Weapons in the U.S.* (Ithaca: Cornell University Press, 1992), 12-28.

problem there is tension between negative and positive control. If there is a shift between negative and positive control it should be done in an orderly, prescribed manner to meet the changing conditions.¹¹⁹

This chapter examines the structure of strategic command and control in South Asia. It begins by examining what is known about the respective command and control structures, including personnel and communication infrastructure. It then examines how conventional forces could pose a threat to command and control, using the 1990-1991 Persian Gulf War as an example of modern targeting and attacks on command and control. Both Indian and Pakistani precision targeting and attack capabilities are then discussed, leading to the conclusion that India has made a major investment in precision targeting and attack, perhaps giving it the potential to severely damage or disrupt Pakistani command and control, possibly even strategic command and control. This could cause Pakistan to use its nuclear weapons, since the loss of command and control of its strategic assets would undermine its military strategy. Pakistan has very limited capability to attack discreet functions such as command and control centers, leaving India in full control of all of its assets. Any successful attack on Indian command, control, communication, computers and intelligence (C4I) probably would only serve to delay a counter-attack. An alternate command and control system, where authority to use nuclear weapons is pre-delegated, is also examined. This system would be more prone to failure and possible inadvertent use of nuclear weapons if used by either India or Pakistan.

B. COMMAND AND CONTROL STRUCTURES

Command and control of strategic nuclear forces is an extremely important process. It is the link between the national command authority, the decision makers who ultimately control the release of the nuclear weapons, and the personnel who have physical control of the weapons themselves. Command and control has been defined as “an arrangement of facilities, personnel, procedures, and means of information acquisition, processing, and dissemination used by a commander in planning, directing,

¹¹⁹ Blair, *Strategic Command and Control*, 281-287.

and controlling military operations.”¹²⁰ I use the terms command and control and C4I interchangeably.

1. India’s Strategic Command and Control

India’s strategic command and control is made up of several components. The first component is the senior national leadership. India first formed a National Security Council (NSC) following the nuclear weapons tests in November 1998. The NSC consists of the prime minister and the ministers of defense, home affairs, finance, and external affairs. The principal secretary to the prime minister has gained the additional designation of national security advisor. The Strategic Policy Group (SPG) has twenty-seven members and consists of the NSC plus additional cabinet ministers, the head of the Atomic Energy Commission, the service chiefs and intelligence chiefs, and the scientific advisor to the minister of defense.¹²¹ Suggestions have been made to form a national command post (NCP) staffed by all services. The NCP would transmit nuclear release authority to a Strategic Command, who would then forward the message to the nuclear capable units.¹²²

The National Security Advisory Board (NSAB) was formed to draft India’s nuclear doctrine after the 1998 nuclear tests. The board was made up of twenty-two members from diverse backgrounds, only four of whom had military experience. India’s foremost defense strategist, K. Subrahmanyam, chaired the group.¹²³ The NSAB published India’s draft nuclear doctrine in 1999, and clearly outlined the basic tenets of command and control. The Prime Minister, or the constitutionally designated line of succession, has release authority. From here strategic command and control becomes murky, but the importance of ensuring the survivability of the C4I is clearly stated.¹²⁴ In 1999, A.P.J. Abdul Kalam, then the head of India’s nuclear weapons programs and now

¹²⁰ Paul J. Bracken, *The Command and Control of Nuclear Forces* (New Haven, Yale University Press, 1983), 3.

¹²¹ Rajesh Kadian, “Nuclear Weapons and the Indian Armed Forces,” in *Nuclear India in the Twenty-First Century*, ed. D.R. SarDesai and Raju G.C. Thomas (New York: Palgrave, 2002), 225.

¹²² Pahwa, *Command and Control of Indian Nuclear Forces*, 54, 57-63.

¹²³ Kadian, “Nuclear Weapons and the Indian Armed Forces,” 226.

¹²⁴ National Security Advisory Board on Nuclear Doctrine, *India’s Draft Nuclear Doctrine*.

the president of India, gave “assurances that India has all the resources necessary to build an adequate command and control structure.”¹²⁵

Figure 4. Suggested Nuclear Chain of Command¹²⁶

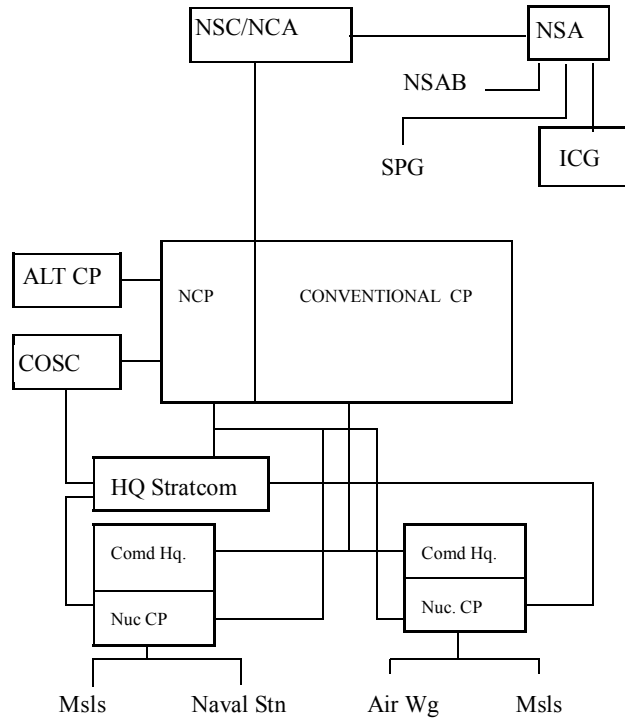

India did not unify the military under a single command structure until the creation of the Chiefs of Staff Committee (COSC) and an integrated military headquarters in 2001.¹²⁷ India recently specified a long-suggested strategic nuclear command to control all nuclear capable forces, when the Chief of the Integrated Defense Staff, Lt. Gen P.C. Joshi, announced the establishment of the Strategic Nuclear Command (SNC).¹²⁸ The first commander of the SNC may be Air Marshal T.M. Asthana, head of IAF Southern Command, and the headquarters may be at

¹²⁵ Bowen and Wolven, “Command and Control Challenges in South Asia,” 29.

¹²⁶ Pahwa, *Command and Control of Indian Nuclear Forces*, 58.

¹²⁷ “Ministry of Defense,” in *Global Security*, downloaded 2 November 2002, at <<http://www.globalsecurity.org/military/world/india.mod.htm>>.

¹²⁸ Kadian, “Nuclear Weapons and the Indian Armed Forces,” 226; and Pahwa, *Command and Control of Indian Nuclear Forces*, 54.

Thiruvananthapuram.¹²⁹ There also have been suggestions that these headquarters may ultimately be emplaced in the Andaman and Nicobar Islands, a remote region far from Pakistan's current strike range. Civilian elites maintain tight control over nuclear weapons, which may be stored in component form, and are kept separate from the delivery systems. The military controls the nuclear delivery systems. The degree of integration between these two entities is unknown.¹³⁰ India may be lacking critical links to a robust nuclear command and control structure by failing to adequately integrate the military into the system.¹³¹ Transporting the nuclear weapons could also be problematic in a crisis situation if the steps have not been adequately thought out or rehearsed.¹³² Joint custody by civilian and military authorities provides stringent safeguards against inadvertent or unauthorized use. However, release of nuclear weapons may be complicated, particularly if each service develops its own delivery systems, requiring multiple command and control channels.

The associated command and control infrastructure may grow as the nuclear arsenal and delivery systems increase over time. India has the resources and the capability to develop a command and control structure to live up to Abdul Kalam's promise. India has an advanced scientific and engineering infrastructure that includes an information and technology sector capable of designing and building advanced computers, software, and communication satellites. India has undergone a communications revolution in the last decade with a rapid growth in TV, radio, telecommunications, and Internet use across the nation.¹³³ This includes fiber-optic

¹²⁹ Rahul Bedi, "Start Date for Indian Strategic Nuclear Command," *Jane's Defense Weekly*, 22 May 2002, at <<http://www4.janes.com/search97>>; "Strategic Forces Command on Anvil," in *The Tribune*, 30 September 2002, at <http://www.tribuneindia.com/2002/20021001/main6.htm>>; and "Strategic Nuclear Command Being Put in Place: Lt. Gen Joshi," *Express India*, 30 September 2002, at <<http://www.expressinida.com/fullstroy.php?newsid=15303>>.

¹³⁰ Winner and Yoshihara, *Nuclear Stability in South Asia*, 34-35.

¹³¹ Sidhu, "India's Nuclear Use Doctrine," 155.

¹³² Howard Diamond, "India Releases Nuclear Doctrine, Looks to Emulate P-5 Arsenals," *Arms Control Today* (July/August 1999).

¹³³ See Arvind Singhal and Everret M. Rogers, *India's Communication Revolution: From Bullock Carts to Cyber Marts* (New Delhi: Sage, 2001) for an in-depth analysis of India's growing telecommunications industry.

cable, microwave radio relay, and a domestic satellite system with 254 earth stations.¹³⁴ The goal of this revolution is to wire the entire country together, but this goal has not been achieved. India has developed the capability to design and manufacture encrypted communication devices and is currently emplacing a national military C4I system.¹³⁵ It is reasonable to assume that India has, or will develop, secure and redundant strategic communications using a variety of methods since it has these technical capabilities.

India can probably be thought of as leaning towards the never side of the nuclear weapons never/always spectrum via stringent negative control features. Such a policy is in keeping with a retaliatory posture that doesn't need to be immediate, but that must be credible. It is also consistent with a cautious, civilian dominated approach to deterrence.

2. Pakistan's Strategic Command and Control

Pakistan has also developed a strategic command and control system made up of several components, and has been fairly open concerning these processes. Pakistan formally announced the creation of a National Command Authority (NCA) on 2 February 2000, following the release of India's draft nuclear doctrine. The head of government, constitutionally the prime minister but currently General Musharraf, has nuclear release authority. The NCA has two committees, the first of which is the Employment Control Committee (ECC). The ECC is chaired by the head of government and is made up of senior political, military, and scientific personnel, and would give the order to use nuclear weapons. The ECC is also charged with setting the employment doctrine, and would meet in a crisis situation. The second committee is the Development and Control Committee (DCC) has responsibility to develop nuclear weapons and their delivery

¹³⁴ *World Factbook 2002*, CIA, 18 October 2002, at <http://www.cia.gov/cia/publications/factbook/geos/in.html#comm>.

¹³⁵ "Army Radio Engineered Radio (AREN)," in *Jane's C4I Systems*, no. 14, ed. Giles Ebbutt (Coulson, UK: Jane's Information Group, 2002), 183; and "Analogue Code Encryption (ACE) Unit," "AZ 7308E Speech Encryption Unit," and "AZ 9870E Applique," in *Jane's Military Communication*, no. 23, ed. John Williamson (Coulson, UK: Jane's Information Group, 2002), 485.

systems. It is also chaired by the head of government, but consists of mostly military personnel and scientific advisors.¹³⁶

The military has significant input and control of all aspects of Pakistan’s strategic programs. The Strategic Plans Division (SPD) has responsibility for the actual command and control of the strategic weapons systems. The head of SPD is Major General Khalid Kidwai. The SPD has four directorates, one of which is the C4I network itself, and includes representatives from all the military services. The SPD appears to have responsibility for the actual security of the nuclear weapons, the delivery systems, and for nuclear targeting as well. However, the exact mechanisms for these separate functions have not been disclosed. The military plays a significant role at every step of the process from formulation of policy to actual control of the nuclear weapons.¹³⁷

Figure 5. Pakistan’s Nuclear Release Authority¹³⁸



¹³⁶“National Command Authority Established,” *Associated Press of Pakistan*, 3 February 2000, <<http://www.fas.org/news/Pakistan/20000/000203-pak-app1.htm>>; and Jones, *Minimum Nuclear Deterrence Postures in South Asia*, 32-33; and Cotta-Ramusino and Martellini, *Nuclear Safety, Nuclear Stability, and Nuclear Strategy in Pakistan*, 4-5.

¹³⁷ Cotta-Ramusino and Martellini, *Nuclear Safety, Nuclear Stability, and Nuclear Strategy in Pakistan*, 4-5; Timothy D. Hoyt, “Pakistani Nuclear Doctrine and the Dangers of Strategic Myopia,” *Asian Survey*, vol. 41, no. 6 (November/December 2001), 964-965; and Jones, *Minimum Nuclear Deterrence Postures in South Asia*, 32-33.

¹³⁸ From Pakistan’s Ministry of Foreign Affairs, 13 November 2002, at <<http://www.forisb.org/NCA.org>>.

Pakistan has not disclosed the communications channels that it uses to conduct strategic C4I. Pakistan has made a significant investment in a national telecommunications system since 1988, although it does not have a well-developed high-tech industry. This includes microwave radio relay, coaxial cable, fiber-optic cables, and satellite links.¹³⁹ Pakistan does not have an advanced information and technology sector capable of designing and building advanced computers or software, however, these are readily available on the commercial market. It is reasonable to assume that Pakistan has, or will develop, secure and redundant strategic communications since the strategic systems are critical to the state, and since the over-all funding of these programs appear to have a high priority. The strategic communications system may mirror the military operational communication system, or use the same infrastructure.

Pakistan can probably be thought of as leaning heavily towards the always side of the nuclear weapons never/always spectrum due to its posture of deterring conventional aggression with nuclear weapons.¹⁴⁰ The heavy influence of the military is also a factor in this assumption. This seems appropriate when one considers Pakistan's policy of nuclear first-use to deter India from making use of its conventional military advantage. Pakistan does have a stringent screening and control system to ensure that personnel involved in the nuclear weapons can be relied upon to perform their duties.¹⁴¹

C. CONVENTIONAL WARFIGHTING IN A NUCLEAR ENVIRONMENT

India and Pakistan last engaged in full-scale conventional war in 1971, prior to the advent of both nuclear weapons and modern precision targeting in South Asia. The Kargil Crisis of 1999 remained at the limited war level, and was largely a localized infantry and artillery battle along the contested border in Kashmir. No attempts were made to expand the scope of this conflict. Therefore, India and Pakistan were unable to fully test any doctrine corresponding to the current vogue of targeting C4I with the goal

¹³⁹ *World Factbook 2002*, CIA, 18 October 2002, at <http://www.cia.gov/cia/publications/factbook/geos/pk.html#comm>.

¹⁴⁰ Hoyt, "Pakistani Nuclear Doctrine and the Dangers of Strategic Myopia," 966.

¹⁴¹ Cotta-Ramusino and Martellini, *Nuclear Safety, Nuclear Stability, and Nuclear Strategy in Pakistan*, 4-5.

of depriving the senior leadership of command and control of the field forces. There is a growing gap between India and Pakistan's precision targeting and attack capabilities, with India having a distinct advantage. This could lead to the targeting of C4I nodes during wartime, especially since this may be the most efficient manner to undermine an opponent's military capability.

1. Historical Examples

Modern war fighting methodology has placed heavy emphasis on striking the enemy's C4I systems. Doctrine developed by the United States to defeat or suppress the opponent's C4I played a major role in U.S. success in Panama in 1989, the Persian Gulf War in 1991, and was also used in Yugoslavia in 1999. This was made possible by advanced intelligence gathering capability coupled with the advent of modern precision-strike munitions.

The 1991 Coalition campaign against Iraq relied heavily upon air power to destroy Iraq's capability to fight. Twelve air campaign target sets were included in the plan to defeat Iraq. Two of the twelve: leadership command facilities and telecommunication and command, control, and communications (C3) nodes, can be considered to be part of C4I. The goal was to isolate and incapacitate Iraq's senior leadership and keep them from influencing the battle.¹⁴² U.S. studies after the war determined that it is difficult to fully understand the effects of the attacks upon enemy C4I. This is partly due to the lack of metrics for measuring the effects of damage to a C4I system. How much of Iraq's C4I was disrupted was impossible to determine. However, there was fifty-seven percent less message traffic, indicating that there was some effect on these systems.¹⁴³ This contrasted with a different analysis of the air war that depicted the tonnage of munitions dropped per month in the Gulf War as roughly equivalent to that of the Second World War and the Vietnam War, but was more decisive in the outcome.¹⁴⁴ Conflicting analysis show the complexity of this issue, however,

¹⁴² Final Report to Congress, *Conduct of the Persian Gulf War* (April 1992), 95-96.

¹⁴³ GAO, *Operation Desert Storm, Evaluation of the Air Campaign*, GA/NSIAD-97-134 (June 1997), appendix III:9.2.2.

¹⁴⁴ FAS Military Analysis Network, *Operation Desert Storm*, 18 October 2002, at <http://www.fas.org/man/dod-101/ops/desert_storm.htm>.

continued emphasis and developments in this field would seem to indicate that this type of warfare will probably grow in emphasis over time, particularly for the well-developed countries.

2. Attacking Command and Control

India has been steadily upgrading its ability to identify and attack discreet targets. Pakistan's lack of strategic depth may make much of its C4I vulnerable. This has taken a dual track approach with a move towards acquiring a robust intelligence gathering capability and the addition of precision weapons. India launched its first imaging satellite in 1979. These early satellites had no real intelligence gathering capability since the best available resolution was 1 km. India's capabilities have matured since then, and higher resolution satellites were launched beginning in the mid-1980s, and the Indian Remote Sensing satellites have a 5.8 meter resolution. However, these satellites do not have advanced all weather or night capability, and they lack timely revisit rates. Indian satellites do not have a real-time capability; meaning imagery is not immediately available for use. Attempts were made to use satellite imagery in the 1999 Kashmir Crisis. The systems lacked the resolution to get a clear picture of what was mostly infantry action, and poor weather further limited its usefulness. However, India does carefully restrict dissemination of imagery of its own sensitive areas, probably indicating that these systems are capable of accurately depicting larger permanent facilities.¹⁴⁵

India has fielded unmanned aerial vehicles (UAVs), and has used them during the recent crisis with Pakistan. The Army is currently using the Searcher in the Kashmir region. The Searcher is a long-endurance multi-role UAV produced in Israel and is capable of giving the local commander a real time picture of events on the battlefield.¹⁴⁶ It does not appear that India will be able to field a longer-range UAV in the near term, but it has developed several short-rang UAVs indigenously.¹⁴⁷ India is also beginning to see a role for unmanned combat aerial vehicles (UCAVs), which will give it a capability

¹⁴⁵ *Commercial Observation Satellites: At the Leading Edge of Global Transparency*, ed. John C. Baker, Kevin M. O'Connell, and Ray A. Williams (Santa Monica: RAND and ANPRS, 2001), 246-258.

¹⁴⁶ Gaurav C. Sawant, "Smart Drones Silently Scan Enemy," in *Indian Express*, 8 June 2002; and "IAI Searcher," in *Jane's Unmanned Aerial Vehicles and Targets*, no. 18, ed. Kenneth Munson (Coulson, UK: Jane's Information Group, 2002), 97-98.

¹⁴⁷ "ADE Kapothaka," and "ADE Nishant," in *Jane's Unmanned Aerial Vehicles and Targets*, no. 18, ed. Kenneth Munson (Coulson, UK: Jane's Information Group, 2002), 62-64.

to not only develop intelligence, but quickly attack as well.¹⁴⁸ When this capability will be acquired is unknown. India also has reconnaissance aircraft, like the MiG-25, capable of providing deep reconnaissance and intelligence.¹⁴⁹

India has been rapidly expanding its arsenal of precision-guided munitions. India has produced several indigenously designed weapons, and acquired others on the arms market. These weapons include laser-guided weapons such as the AS-30L and Kh-29L/T, both of which are designed for attacking high value targets. India has also acquired a number of anti-radar missiles, giving it the capability to suppress Pakistan air defenses and go after the high value targets.¹⁵⁰ The Mirage 2000 has been equipped with laser designation pods, making it a true multi-role aircraft. Two squadrons of Mirage 2000s are currently operational, and more aircraft have been ordered to keep the units at full strength.¹⁵¹ The recently acquired and operational SU-30 is also equipped to perform missions in either the air superiority or ground attack mode. The SU-30 has both infrared and laser targeting equipment, and can perform almost any tactical mission.¹⁵² India has signed agreements with Russia to produce 140 SU-30 aircraft over the life of the contract, giving it a growing capability today and tremendous capability in the future.¹⁵³ India's Prithvi series of missiles have been developed to give sufficient accuracy to hit smaller targets.¹⁵⁴

India appears to be making a concerted effort to destroy high value targets, by making a real investment in precision-guided munitions and in the aircraft to deliver them. This gives India the potential capability to alter battlefield dynamics by attacking

¹⁴⁸ C.N.Ghosh, *Application of Unmanned Combat Aerial Vehicles in Future Battles of the Subcontinent*, 29 August 2002, at <<http://www.idsa-india.org/an-jly-9.01.htm>>.

¹⁴⁹ Satmir Singh, BG, *Shaping the Battlefield Through Remote Sensing and Satellite Imagery*, 29 August 2002, at <<http://www.idsa-india.org/an-feb00-5.html>>.

¹⁵⁰ "Missile Armoury," at *Bharat Rakshak* website, 15 August 2002, at <http://bharat-rakshak.com/IAF/Info/Missile.html>; and "AS-14 'Kedge' (KH-29)" in *Jane's Air Launched Weapons*, no. 40, ed. Robert Hewson (Coulson, UK: Jane's Information Group, 2002), 189-190.

¹⁵¹ "Mirage 2000," at *Bharat Rakshak* website, 15 August 2002, at <<http://www.bharat-rakshak.com/IAF/Info/Aircraft/Mirage-2000.html>>.

¹⁵² "SU-30 Flanker," at *Bharat Rakshak* website, 15 August 2002, at <<http://www.bharat-rakshak.com/IAF/Info/Aircraft/Su-30.html>>.

¹⁵³ Sanu Kainikara, "Indian Air Force: News Updates," *Asia-Pacific Defense Reporter* (February 2001), 62.

¹⁵⁴ Jane's, "Prithvi (SS-150/-250/-350)(P-1/P-2/P-3) and Dhanush".

C4I nodes. India's increased capability to identify and attack discreet targets may give it the capability to damage Pakistan's strategic C4I. India would likely attack corps level assets including unit headquarters, communication infrastructure, and critical units or equipment. The fact these some of these targets may be indistinguishable from, or overlap that of the strategic C4I, makes for a sensitive situation. This could lead to a loss of command and control of strategic forces by Pakistan. Under these circumstances the national command authorities might fear the loss of the ability to control the strategic nuclear force. This could lead Pakistan's leadership to give the release orders to the strategic forces that they are still in contact with while they can still affect some degree of deterrence. This is another example of inadvertent escalation.

Pakistan could try to attack India's C4I with fighter-bombers and conventionally armed ballistic missiles. However, it is difficult to identify and target such discrete command nodes, requiring both long-range intelligence gathering capability and precision munitions. Pakistan has not developed any imagery satellites, and is lacking in long-range reconnaissance aircraft. Pakistan has been developing and using remote piloted vehicles.¹⁵⁵ The Indian army identified and shot down a number of Pakistani UAVs in the Kashmir region. Pakistan is also developing the Vector UAV, which is advertised as having a range of 200km, and uses the global positioning system.¹⁵⁶ Pakistan also has identified a need for acquiring improved surveillance capability, and has requested the Predator UAV from the U.S. government.¹⁵⁷

Pakistan's inventory of air deliverable ordnance consists of less sophisticated general-purpose gravity bombs and rockets. Most of these munitions are based upon U.S. bomb designs and are advertised as being able to mate with laser-guided bomb kits.¹⁵⁸

¹⁵⁵ "AWC Bravo," "AWC Mk I and II," "AWC Vision I and II," "NDC Vector," and "DGMP Hud Hud I and II," in *Jane's Unmanned Aerial Vehicles and Targets*, no. 18, ed. Kenneth Munson (Coulson, UK: Jane's Information Group, 2002) 126-130.

¹⁵⁶ Sawant, "Smart Drones Silently Scan Enemy"; and "Pakistan Develops Unmanned Aerial Vehicle," in *Indian Strategic Review*, June 6, 2002, at <http://members.tripod.com/israindia/isr/june6/index.html>.

¹⁵⁷ Andrew Koch, "Pakistan Looks to USA to Fill UAV Gap," *Jane's Defense Weekly* (2 October 2002), 4.

¹⁵⁸ "124 kg and 250kg Prefragmented Bombs," "Mk 80 Series Bombs," "Mk P8 227 kg Bombs," and "PSD-1 and TSD-1 Hijara," in *Jane's Air Launched Weapons*, no. 40, ed. Robert Hewson (Coulson, UK: Jane's Information Group, 2002), 408-415.

Pakistan probably has some modern, sophisticated air deliverable precision munitions capable of destroying C4I targets, but the quantities are unknown. Pakistan's aircraft may not be equipped with the necessary avionics and sighting systems to attack discrete targets, although many aircraft have received some type of upgrades. Pakistan's ballistic missiles have a large circular error probability (CEP), which makes them suitable for attacking area targets only.¹⁵⁹ These shortages may lead to an overall inability to attack discrete targets to a sufficient degree necessary to cause failures in India's C4I.

Pakistan's relative inability to identify and attack India's C4I probably precludes any appreciable loss of command and control over India's strategic force during a conventional war. This is reinforced by a number of factors, including India's reliance on negative control features, and greater strategic depth. With India's probable separation of delivery systems and warheads it is highly unlikely that any loss of control would cause an unauthorized launch of India's nuclear weapons, or any real diminished discrimination in the use of its nuclear weapons. However, damage to India's strategic command and control system may delay the use of nuclear weapons in the retaliatory role.

D. ALTERNATE COMMAND AND CONTROL STRUCTURES

Are there alternatives to the command and control structures discussed earlier in this chapter? The general pronouncements made in India and Pakistan does not necessarily mean that survivable strategic command and control structures are in place. This is particularly true of India where little is known on the complete C4I structure due to the lack of official government statements. The pressures of conventional combat could place a strain on an immature or less developed system. During the Cold War the Soviet Union developed the capability to attack U.S. strategic C4I. This caused the United States to enhance its early warning capability. The United States also developed a more survivable C4I system, including an airborne strategic command post. There was also some consideration to pre-delegating nuclear launch authority to ensure a nuclear response in time of crisis.¹⁶⁰

¹⁵⁹ Jane's, "Hatf 3".

¹⁶⁰ Blair, *Strategic Command and Control*, 138, 284-286.

Pakistan may be predisposed to pre-delegate release authority for nuclear weapons to ensure that the nuclear option will be available during a crisis.¹⁶¹ There is some evidence of pre-delegation to support this proposal. Prof. Pervaiz Hoodbhoy, a noted anti-nuclear weapon activist, believes that release authority for Pakistan's nuclear weapons has been pre-delegated to subordinate commanders, possibly to corps commanders or even lower. Such pre-delegation of authority may be thought necessary to overcome communication difficulties caused by the wide dispersal of strategic weapons systems to remote areas as a hedge against a pre-emptive attack by India.¹⁶² Such a system would appear to be reasonable since Pakistan relies upon its strategic forces for deterrence. If Pakistan does pre-delegate nuclear release authority, then the degree of command and control of Pakistan's nuclear forces exercised by the senior leadership in a crisis situation might be questionable. Inadvertent nuclear escalation under these circumstances could be due to the mistaken assumption that the conditions for using nuclear weapons had been met. Pre-delegation of nuclear release authority has been strongly denied by Pakistan.¹⁶³

E. CONCLUSION

Large-scale conventional warfare between India and Pakistan has the potential to threaten vital strategic command and control functions. This is particularly true for Pakistan since India has made a major investment in intelligence gathering and precision-strike capability. In a military dominated system such as Pakistan's there may also be a significant overlap between the normal conventional operational command and control structures that would be subject to attack in a large-scale war and with it the strategic command and control structure. If Pakistan lost command and control of its strategic forces it could cause the national command authorities to order the use of its remaining strategic nuclear forces while they can still affect some degree of deterrence.

¹⁶¹ Hoyt, "Pakistani Nuclear Doctrine and the Dangers of Strategic Myopia," 964-966.

¹⁶² David Blair, "Finger on Nuclear Button is Not Musharraf's," *London Daily Telegraph*, 7 June 2002, at <<http://ebird.dtic.mil/Jun2002/e20020607finger.htm>>.

¹⁶³ Cotta-Ramusino and Martellini, *Nuclear Safety, Nuclear Stability, and Nuclear Strategy in Pakistan*, 4.

Pakistan's inability to identify and attack India's C4I probably precludes any appreciable loss of command and control over India's strategic force during a conventional war. This is reinforced by a number of factors, including India's reliance on negative control features, and greater strategic depth. A conventional attack on India's command and control structures would probably only delay a retaliatory nuclear attack, and not lead to the inadvertent use of nuclear weapons.

There are no indications that India has pre-delegated nuclear release authority. However, it may find that its strategic command and control functions are unable to cope with the effects of a full-scale conventional war. President Abdul Kalam's statements that "nuclear command and control is mostly for deployment" might indicate that some steps in the process are not in place.¹⁶⁴ Under such circumstances India's senior leadership may have to cobble together a system while under pressure. There are no indications that Pakistan has pre-delegated nuclear release authority. However, it too may find that its strategic command and control functions are unable to cope with the effects of a full-scale war. Pakistan would be under tremendous pressure to create a workable system if its strategic command and control system is at risk. Pakistan's reliance upon nuclear deterrence could force it to adopt pre-delegation of nuclear release authority if there were no other method to ensure delivery.

¹⁶⁴ Jay Solomon, "Indian President-Elect Kalam Says Nation's Nuclear Arsenal is Secure," *Wall Street Journal* (22 July 2002), at <http://ebird.dtic.mil/Jul2002/e20020722indian.htm>.

THIS PAGE INTENTIONALLY LEFT BLANK

V. FEAR OF PRE-EMPTION

A. INTRODUCTION

Can conventional warfare lead to the attacking forces being mistaken for a pre-emptive attack? Will India and Pakistan adopt a posture to guard against a pre-emptive strike? A third scenario can be added to the two previously discussed scenarios. Inadvertent escalation can be initiated if one side loses its early warning capability.¹⁶⁵ However, if one side adopted a launch-on warning or launch-under-attack policy to defend against the perceived threat of a pre-emptive attack, then any air or ballistic missile attack could be considered as pre-emption, and lead to escalation

A pre-emptive attack is a first-strike designed to destroy or neutralize strategic assets. A conventional attack could be mistaken for a pre-emptive attack, and could start a nuclear alert cycle and cause a launch-on-warning. Both the United States and the Soviet Union had nuclear forces on alert throughout much of the Cold War, and a launch-on-warning or launch-under-attack posture at times during the Cold War. The superpowers build extremely sophisticated early warning systems and a robust command and control infrastructure to ensure adequate warning. Under these circumstances any unidentified aircraft penetrations or missile launch could have been mistaken for an attack or first strike. India and Pakistan have not reached that level of technical sophistication. Other factors may over-ride technical capabilities and convince one of the states to adopt a launch-on-warning posture. Factors such as fear of pre-emption, and a lack of response time and inadequate warnings, could lead to strategic forces being placed in a launch-under-warning posture.

This chapter examines how conventional air or missile attacks in South Asia could be mistaken for a pre-emptive strike on strategic weapon systems. It begins by examining the early-warning and launch-on-warning postures of the superpowers during the Cold War. This chapter then examines India and Pakistan's ability to target and attack the adversary's strategic forces with conventional weapon systems. Next, India's growing defensive capability is examined with a focus on the potential for India to deny

¹⁶⁵ Posen, *Inadvertent Escalation*, 2.

success to a weakened Pakistani nuclear second-strike. Pakistan's less robust defensive capabilities are then explored. Finally, scenarios that consider the possibility of either air- or ballistic missile attacks prompting a launch-on-warning or launch-under-attack are studied. India's growing precision-targeting and -strike capability may pose a threat to the survivability of Pakistan's strategic nuclear assets, if not now, then in the near-term. Pakistan may come to fear an Indian pre-emptive attack upon its strategic nuclear assets due to India's growing capabilities. This may cause Pakistan to adopt a launch-on-warning or launch-under-attack posture during a crisis situation. This then could cause any Indian air or ballistic missile attack upon Pakistan to be mistaken for pre-emption, and compel Pakistan to use its nuclear forces.

B. THE TOOLS OF PRE-EMPTION

Is there a real threat of pre-emption in South Asia? This section will explore whether India and Pakistan have the tools necessary for a successful pre-emptive attack, especially precision targeting capability and precision-attack munitions. India and Pakistan are sensitive to any unknown aircraft or missiles entering its airspace due to the short time of flight for both aircraft and ballistic missiles, and signed an agreement in 1991 to prevent air space violations.¹⁶⁶ There is a risk of misinterpreting the other's actions during peacetime tests, or when under aircraft or conventional ballistic missile attacks during times of war or crisis.¹⁶⁷ A tenet of stable nuclear deterrence is that neither side can have the incentive, nor the capability to destroy the other's nuclear forces on the ground. The growing capability of precision conventional offensive weapon systems combined with improved intelligence gathering ability may be a threat to strategic weapon systems. A robust air and missile defense could then serve to deny the necessary level of punishment of a weakened second-strike, effectively undermining deterrence.

¹⁶⁶ "Agreement between India and Pakistan on prevention of air space violations and for permitting over Flights and landings by Military Aircraft," 6 April 1991, at

<http://www.indianembassy.org/South_Asia/Pakistan/Airspace_Violations_Agreement_April_6_1991.html>.

¹⁶⁷ Kent L. Biringier, "Missile Threat Reduction and Monitoring in South Asia," in *The Stability-Instability Paradox: Nuclear Weapons and Brinkmanship in South Asia*, ed. Michael Krepon and Chris Gagne (Washington, D.C.: The Harry L. Stimson Center, June 2001), 64-65.

1. Historical Example

Deterrence consists of having the capability and the will to retaliate with nuclear weapons, and your opponent clearly recognizing that such conditions exist.¹⁶⁸ The United States and the Soviet Union were aware of the advantages of striking first in the 1950s and 1960s.¹⁶⁹ Both the United States and the Soviet Union feared the possibility of pre-emptive attacks and began to build the infrastructure to ensure that they would be able to launch many of their strategic weapons even if under attack. This included putting nuclear forces on alert throughout much of the Cold War, and adopting a launch-on-warning or launch-under-attack posture at times of heightened tension such as during the Cuban Missile Crisis. Space based intelligence and reconnaissance satellites, radars, and airborne early warning systems were developed at great cost. Each side developed a robust and redundant command and control infrastructure to ensure adequate first-strike warning.¹⁷⁰

The United States and Soviet Union had good reason to develop a launch-on-warning capability. As nuclear arsenals matured they became more accurate, and gave each side the potential to launch a pre-emptive strike upon the other's strategic assets, especially with missiles armed with multiple warheads. There was about a thirty minute warning for an ICBM attack, and as little as 15 minutes for a SLBM attack. This caused both states to adopt a launch-on-warning posture. Parts of this system were still in place in January 1995 when a Norwegian scientific test rocket was mistaken for a missile attack on Russia, almost causing Russia to launch its missiles. Norway had notified Russia of the pending test, but the military personnel serving in the early-warning center did not receive this information.¹⁷¹

¹⁶⁸ Ibid, 16.

¹⁶⁹ Morton H. Halperin, *Limited War in the Nuclear Age* (New York: John Wiley and Sons, 1963) 11-13.

¹⁷⁰ Bracken, *The Command and Control of Nuclear Forces*, 5-73, 82-83.

¹⁷¹ Bruce G. Blair, Harold A. Feiveson, and Frank von Hippel, "Taking Nuclear Weapons Off Hair Trigger Alert," *Scientific American* (November 1997), 74-81.

2. Precision Targeting and Attack in South Asia

Does India have the necessary precision targeting and precision-strike munitions to conduct a pre-emptive attack on Pakistan? Pakistan's lack of strategic depth may make much of its strategic nuclear assets vulnerable to attack. India has been steadily upgrading its ability to identify and attack these types of targets. This includes acquiring a robust intelligence gathering capability and precision-strike munitions. India has imagery satellites, but these satellites do not have advanced all weather or night capability, lack timely revisit rates, and don't have real-time capability. Since India carefully restricts access of imagery of its own sensitive areas, this seems to indicate that these systems are capable of accurately depicting similar areas in Pakistan.¹⁷²

India has fielded UAVs, and has used them during the December 2001 to October 2002 crisis with Pakistan. The Army is currently using the Searcher, a long-endurance multi-role UAV produced in Israel, in the Kashmir region. It is capable of giving the local commander a real-time picture of events on the battlefield.¹⁷³ It does not appear that India will be able to field a longer-range UAV in the near term, but it has developed several short-range UAVs.¹⁷⁴ India is also beginning to see a role for unmanned combat aerial vehicles, which will not only give it a capability to develop intelligence, but quickly attack as well. However, this capability has not been acquired.¹⁷⁵ India also has reconnaissance aircraft, such as the MiG-25, capable of providing deep reconnaissance and intelligence.¹⁷⁶

India has been rapidly expanding its arsenal of precision-guided munitions. These weapons include laser-guided weapons and anti-radar missiles, giving it the capability to both suppress Pakistan air defenses and go after high value targets.¹⁷⁷ The Mirage 2000 has been equipped with laser designation pods, making it a true multi-role aircraft. Two squadrons of Mirage 2000s are currently operational, and more aircraft have been ordered

¹⁷² *Commercial Observation Satellites: At the Leading Edge of Global Transparency*, 246-258.

¹⁷³ Sawant, "Smart Drones Silently Scan Enemy"; and "IAI Searcher".

¹⁷⁴ Jane's, "ADE Kapothaka," and "ADE Nishant".

¹⁷⁵ Ghosh, *Application of Unmanned Combat Aerial Vehicles in Future Battles of the Subcontinent*.

¹⁷⁶ Singh, *Shaping the Battlefield Through Remote Sensing and Satellite Imagery*.

¹⁷⁷ Bharat Bakshak, "Missile Armoury"; and Jane's "AS-14 'Kedge' (KH-29)".

to keep the units at full strength.¹⁷⁸ The recently acquired and operational SU-30 is also equipped to perform missions in either the air superiority or ground attack mode. With both infrared and laser targeting equipment, it can perform almost any tactical mission.¹⁷⁹ India has signed agreements with Russia to produce 140 SU-30 aircraft over the life of the contract, giving it a growing capability today and tremendous capability in the future.¹⁸⁰ India's Prithvi series of missiles have been developed to give sufficient accuracy to hit smaller targets.¹⁸¹ India appears to be making a concerted effort to destroy high value targets by making a real investment in precision-guided munitions and in the aircraft to deliver them. This gives India the capability to potentially damage some, but not all, of Pakistan's strategic assets.

Does Pakistan have the necessary precision targeting and precision-strike munitions to conduct a pre-emptive attack on India? Pakistan could try to attack India's strategic nuclear assets with fighter-bombers and conventionally armed ballistic missiles. This would require the ability to identify and target these assets, requiring both long-range intelligence gathering capability and precision munitions. Pakistan has not developed any imagery satellites, and is lacking in long-range reconnaissance aircraft, but is developing and using remote piloted vehicles.¹⁸² The Indian army identified and shot down a number of Pakistani UAVs in the Kashmir region. Pakistan is also developing the Vector UAV, which is advertised as having a range of 200km, and uses the global positioning system.¹⁸³ Pakistan has also identified a need for acquiring improved surveillance capability, and has requested the Predator from the U.S. government, but approval has not been granted.¹⁸⁴

¹⁷⁸ Bharat Bakshak, "Mirage 2000".

¹⁷⁹ Bharat Bakshak, "SU-30 Flanker".

¹⁸⁰ Kainikara, "Indian Air Force: News Updates," 62.

¹⁸¹ Jane's, "Prithvi (SS-150/-250/-350)(P-1/P-2/P-3) and Dhanush".

¹⁸² Jane's, "AWC Bravo," "AWC Mk I and II," "AWC Vision I and II," "NDC Vector," and "DGMP Hud Hud I and II".

¹⁸³ Sawant, "Smart Drones Silently Scan Enemy"; and "Pakistan Develops Unmanned Aerial Vehicle".

¹⁸⁴ Koch, "Pakistan Looks to USA to Fill UAV Gap," 4.

Pakistan's inventory of air-deliverable ordnance consists mostly of less sophisticated general-purpose gravity bombs and rockets. Many of these munitions are based upon U.S. bomb designs and are advertised as being able to be fitted with laser-guided bomb kits.¹⁸⁵ Pakistan may have some modern, sophisticated air deliverable precision munitions capable of destroying strategic assets, but the quantities of these munitions are unknown. Pakistan's aircraft may not be equipped with the necessary avionics and sighting systems to attack small discrete targets, although many aircraft have received some upgrades. The current CEP of Pakistan's ballistic missiles makes them unsuitable for attacking point targets, but they are probably capable of severely damaging area targets like airfields.¹⁸⁶ These shortages may lead to an overall inability to attack small targets such as ballistic missiles or nuclear weapon storage bunkers necessary to destroy or neutralize India's second-strike capability.

C. EARLY WARNING AND DEFENSE POSTURE

Both India and Pakistan have the capability to detect aircraft using ground-based radar. Neither state is able to detect initial missile launches, but there is a limited ability to track incoming ballistic missiles. India is upgrading its air defenses, while Pakistan will in all likelihood lag even further behind India in this capability. This could have a major impact on the possibility of pre-emptive attacks.

1. India's Air and Missile Defenses

India has a much more robust air defense system than Pakistan, as explained in Chapter 3. India has a nation-wide advanced air defense ground environment system linking military and civilian radars into a coordinated network. This multi-layered air defense system could probably detect a Pakistani air attack. India's air defense system would probably be adequate to direct the defense against a Pakistani attack.¹⁸⁷ India's air defenses consist of fighter aircraft, SAMs, and air defense artillery.¹⁸⁸ India also has

¹⁸⁵ Jane's, "124 kg and 250kg Prefragmented Bombs," "Mk 80 Series Bombs," "Mk P8 227 kg Bombs," and "PSD-1 and TSD-1 Hijara."

¹⁸⁶ Jane's, "Hatf 3".

¹⁸⁷ Badri-Maharaj, *Strategic Air Defenses in Nuclear South Asia*.

¹⁸⁸ Jane's, "Army, India."

thirty-eight squadrons of surface to air missile. India is currently building an anti-tactical missile screen, made up of Russian built S-300 (SA-10 Giant) and Indian Akash missiles, but it is not clear when these systems will be operational.¹⁸⁹ Indian officials admitted that they have not completed a system that can defeat a Pakistani missile attack.¹⁹⁰ However, these missiles are considered to be capable of destroying tactical ballistic missiles, and may give India the capability to defeat a limited number of shorter-range ballistic missiles.¹⁹¹ While this system is incapable of defeating all missile attacks it can limit damage if deterrence fails, particularly if the attack itself is limited.¹⁹²

2. Pakistan's Air and Missile Defenses

Pakistan has a comprehensive radar network incorporating a wide array of military sites and civilian air traffic control radars, also explained in Chapter 3. Pakistan has a good capability to detect aircraft, but has very limited time to respond since many important installations are very close to the Indian border. Pakistan's air defense capabilities consist of a mixture of aircraft, SAMs, and air defense artillery. Pakistan has very limited surface-to-air-missile capability, but there are large numbers of anti-aircraft guns, with perhaps as many as 43 regiments.¹⁹³ While national coverage is less than adequate, sensitive facilities may have adequate defensive coverage to make them difficult to attack. Pakistan does not have any type of defense against ballistic missiles and is unlikely to acquire them, since it deems them to be destabilizing.¹⁹⁴ Pakistan requested U.S. Patriot missiles in November 2002, but is unlikely to receive them. There is recognition in Pakistan that India's growing ABM capability could erode Pakistan's deterrence capability.¹⁹⁵

¹⁸⁹ Jane's, "SA-10/20 'Grumble' (S-300, S-300 PMU, Buk/Favorit/5V55/48N6)"; and "Akash."

¹⁹⁰ "India buys Green Pine radars for missile defence," *Jane's Defense Weekly*, vol. 38 (10 July 2002), 2.

¹⁹¹ Badri-Maharaj, *Strategic Air Defenses in Nuclear South Asia*.

¹⁹² Basrur, "Missile Defense and South Asia: An Indian Perspective," 10.

¹⁹³ Badri-Maharaj, *Strategic Air Defenses in Nuclear South Asia*.

¹⁹⁴ Ahmed, "Missile Defense in South Asia: A Pakistani Perspective," 26.

¹⁹⁵ "Pakistan to Acquire Anti-ballistic Missile System," in *Defense Journal* (November 2002), at <http://www.pakistaniddefense.com/news/FullNews/November2002/Pak-US_ABM.htm>.

D. CONVENTIONAL WARFIGHTING IN A NUCLEAR ENVIRONMENT

Neither India nor Pakistan can be thought of as having well-developed early warning systems capable of detecting a nuclear strike under all circumstances. However, both countries have pretty good radar networks capable of detecting most aircraft intrusions. India is beginning to build an early warning system capable of detecting ballistic missiles. The biggest difference is in defensive capabilities. India's layered air defense system is designed to prevent the attack of key installations and centers from aircraft, and there is a growing anti-ballistic missile capability. Pakistan also has a layered air defense system, but it is more limited than India's, forcing Pakistan to rely more upon survivability and an assurance of a counter-strike. These asymmetrical strategic warning capabilities when combined with nuclear doctrine yields some interesting results in a conventional environment.

1. Air Campaign

Pakistan has the capability to detect an air attack from India, but probably could not stop a serious attack from reaching key installations. Pakistan's less developed defensive capabilities coupled with the greater number of Indian aircraft would seem to suggest that some Indian aircraft would get through, even if the qualitative superiority of aircraft and relative skills of pilots are totally discounted. Pakistan's strategic forces may have a launch-on-warning or launch-under-attack doctrine, given its reliance upon its nuclear deterrent. Pakistan may also believe that India may launch a pre-emptive strike to incapacitate Pakistan nuclear forces. The combination of India's conventional aircraft armed with precision-munitions and a growing air defense and anti-missile capability may lead Pakistan to think that India plans a pre-emptive strike. This could mean that the normal give and take of aerial combat surrounding a conventional conflict could quickly escalate and cross the nuclear threshold. Under these circumstances Pakistan's national level command could feel it necessary to adopt a launch-on-warning or launch-under-attack posture. This could cause any Indian air attack to be regarded as a pre-emptive attack and lead to Pakistani using its nuclear weapons.

If Pakistan were to launch an air attack on India it would probably be detected. India has a robust multi-layered air defense network and greater numbers of aircraft

available for air defense than Pakistan has to make an attack. Indian air defenses, consisting of SAM and fighter aircraft, would likely render a good account of themselves. However, it is inevitable that some aircraft will get through, and this may have serious results, particularly if the aircraft are armed with nuclear weapons. However, given India's defenses, strategic depth and retaliatory nuclear doctrine, India may not feel the need to adopt a launch-on-warning or launch-under-attack posture. India may not consider a Pakistani offensive air strike to be an attempt to pre-empt, nor may it care, given its doctrinal retaliatory posture. In this regard India's capabilities appear to match with its draft nuclear doctrine.

2. Ballistic Missile Attacks

Pakistan could not detect an Indian ballistic missiles attack until it was too late. Even if it could detect the attack it does not have any missile defenses, nor are they likely to be developed at any time in the near future. Pakistan may not be able to determine that it had been attacked with ballistic missiles until after the attack. A ballistic missile attack would be a major escalation of hostilities. The combination of India's ballistic missiles armed with a low CEP and a growing air defense and anti-missile capability may lead Pakistan to believe that any ballistic missile attack by India was an attempted pre-emptive strike designed to neutralize Pakistan's strategic nuclear weapons. Under these circumstances Pakistan's national level command could feel it necessary to adopt a launch-on-warning or launch-under-attack posture. This could cause any Indian ballistic missile attack to be regarded as a pre-emptive attack and lead to Pakistani using its nuclear weapons.

Pakistan's ballistic missiles are the biggest threat to India. India's current ballistic missile defenses are insufficient to completely stop such an attack. If Pakistan were to launch a ballistic missile attack on India it would probably be detected. Indian ballistic missile defenses, consisting of the S-300 Giant and Akash SAMs, would probably be able to destroy some of the incoming SRBMs. However, it is probably inevitable that some missiles will get through, particularly Pakistan's longer-range Ghauri missiles that have a much higher re-entry velocity. India may not feel the need to conduct a launch-on-warning or launch-under-attack, due to its defenses, strategic depth and retaliatory

nuclear doctrine. India may not consider a Pakistani ballistic missile attack to be an attempt to pre-empt, nor might it care, given its doctrinal retaliatory posture. In this regard India's capabilities appear to match up with its draft nuclear doctrine.

E. CONCLUSION

Large-scale conventional warfare between India and Pakistan could include air and ballistic missile attacks. These attacks have the potential to be interpreted as pre-emptive attacks to destroy or neutralize the adversary's nuclear capability. This is particularly true for Pakistan since India has made a major investment in improving its intelligence gathering and precision-strike capability. India also has made a major investment in defensive measures, including a limited ballistic missile defense. Pakistan may believe that India is trying to gain the ability to launch a pre-emptive attack and deny Pakistan the ability to counter with an effective second-strike with a reduced force. This may lead Pakistan to adopt a launch-on-warning or launch-under-attack posture where any Indian air- or ballistic missile attack could be interpreted as a pre-emptive strike and cause Pakistan to launch its nuclear weapons.

Pakistan's limited ability to identify and attack India's strategic nuclear assets probably precludes any appreciable loss of India's retaliatory capability even if Pakistan launched a pre-emptive attack. This is reinforced by a number of factors, including India's greater strategic depth, and superior air and ballistic missile defenses. An air- or ballistic missile attack on India's would probably elicit a strong response, but probably not a nuclear response.

VI. CONCLUSION

Conventional war in South Asia could lead to inadvertent nuclear escalation. The growing capabilities gap could lead to an even greater instability in the region. The United States has significant interests in helping the region reach a long-term solution, and is the only nation positioned to positively influence both India and Pakistan. This chapter concludes the thesis by citing findings, implications, and making some suggestions for U.S. policy to help India and Pakistan resolve their differences.

A. FINDINGS

Can India and Pakistan fight a conventional war and avoid the use of nuclear weapons? The answer is maybe. The circumstances and conditions outlined in this thesis show that conventional warfare between India and Pakistan could inadvertently escalate to the use of nuclear weapons. Asymmetries in strategic force structure and doctrine, and differences in strategic depth, coupled with an aggressive conventional war fighting doctrine combine to make conventional warfare between India and Pakistan, whether limited or full-scale, a very risky proposition. These structural factors undermine the concept of a stable nuclear deterrent.

This is particularly true for Pakistan since it has not eschewed a first-strike option. Pakistan's perceived vulnerability due to its lack of strategic depth and disparity in conventional military power compared to India has led to a dangerous situation on the subcontinent. A full-scale conventional war will most likely meet one, if not all, of the conditions under which conventional war could inadvertently escalate to nuclear war. There is a strong possibility that conventional forces will put strategic forces at risk, damage strategic C4I, or possibly prompt a launch-on-warning/launch-under-attack due to fears of a pre-emptive attack. A more limited war may reduce these risks, but could in turn escalate to a full-scale war where these risks are fully realized. In short, more intense fighting is the risks of inadvertent nuclear escalation.

1. Survivability at Risk

Large-scale conventional warfare between India and Pakistan has the potential to threaten the survival of strategic nuclear forces, particularly those of Pakistan. The asymmetries of strategic depth and offensive military capability give India an advantage, and may lead to Indian conventional ground or air forces coming into contact with Pakistan's strategic nuclear forces. Pakistan's shorter-range Hatf 3/M-11 ballistic missile must be stationed fairly far forward to range strategic targets in India, perhaps leaving them vulnerable to both air and ground attack. The same is true of Pakistan's forward airbases, which are within easy striking distance of the border. This is a very troubling situation since Pakistan places great emphasis on its strategic nuclear forces to deter a large-scale conventional attack by India. The survival of Pakistan's strategic forces is critical to Pakistan, and a threat to these forces may prompt Pakistan to launch a nuclear attack while the strategic forces are still intact and capable of being used. Survivability is less of an issue during a limited war. However, limited war could escalate to full-scale war, where issues of survivability could become a major concern. Pakistan's de-facto first-use option is intended to deter Indian attack, and is indicative of Pakistan's concerns.

India's greater strategic depth gives it the ability to widely disperse its strategic nuclear forces to areas beyond the normal range of Pakistani ground and air operations. Indian vulnerability is further decreased by longer-range platforms, such as the SU-30 and the Agni missile series. This would seem to preclude inadvertent escalation on India's part when combined with India's presumed retaliatory only nuclear doctrine.

2. Command and Control Threatened

Large-scale conventional warfare between India and Pakistan has the potential to threaten vital strategic command and control functions. This is particularly true of Pakistan since India has made a major investment in intelligence gathering and precision-strike capability. There may also be a significant overlap between Pakistan's conventional operational command and control structures that would be subject to attack in a large-scale conventional war, and the strategic command and control structure. If Pakistan lost command and control of its strategic forces it could cause the national

command authorities to order the use the strategic nuclear forces while Pakistani leadership can still exercise command functions over the strategic forces.

Pakistan's inability to identify and attack India's C4I probably precludes any appreciable loss by India of the command and control over its strategic force during a conventional war. This is reinforced by a number of factors, including India's reliance on negative control features, and greater strategic depth. A conventional attack on India's command and control structures would probably only delay a retaliatory nuclear attack, and not lead to the inadvertent use of nuclear weapons.

3. Fear of Pre-emption

Large-scale conventional warfare between India and Pakistan could include air and ballistic missile attacks. These attacks have the potential to be interpreted as pre-emptive attacks to destroy or neutralize the adversary's nuclear capability. This is particularly true of Pakistan since India has made a major investment in improving its intelligence gathering and precision-strike capability. India has also made a major investment in defensive measures, including a limited ballistic missile defense. Furthermore, Pakistan may believe that India is trying to gain the ability to launch a pre-emptive attack and deny Pakistan the ability to counter with an effective second-strike with a reduced force. Pakistan may feel it necessary to adopt a launch-on-warning or launch-under-attack posture to deter pre-emption. Pakistan's weaker defenses compound this threat, and if Pakistan adopts a launch-on-warning posture then any Indian air- or ballistic missile attack could be interpreted as a pre-emptive strike and cause Pakistan to use its nuclear weapons.

Pakistan's limited ability to identify and attack India's strategic nuclear assets probably precludes any appreciable loss of India's retaliatory capability even if Pakistan launched a pre-emptive attack. This is reinforced by a number of factors, including India's greater strategic depth, and superior air and ballistic missile defenses. An air or ballistic missile attack on India's would probably elicit a strong response, but probably not a nuclear response.

B. IMPLICATIONS

There are major implications to these findings. India's willingness to engage in a limited war effectively undermines the effectiveness of what has been called the stability-instability paradox. This increases the likelihood of conventional war in South Asia, the first step towards what could lead to nuclear escalation. The current situation in South Asia is crisis instable, and will force changes in the way security is viewed in the region. Recognition of these factors will ultimately lead to changes in force structure and doctrine in an attempt to improve security, but may add to greater risks in the short-term

1. Stability-Instability Paradox

India believes that Pakistan uses its nuclear weapons to deter India from responding to aggression in Kashmir, leading to what has been termed the stability-instability paradox.¹⁹⁶ Nuclear weapons are supposed to provide stability by preventing escalation to a major war. However, offsetting capabilities may allow an aggressor to use lower levels of violence (instability) in pursuit of its goals, without risk of major reprisal.¹⁹⁷ The stability-instability paradox assumes that a certain level of violence is sustainable, and is relatively risk free. India's response in the 1999 Kargil Conflict and subsequent adoption of a limited war doctrine was designed to put an end to Pakistan's alleged adventurism.¹⁹⁸

Indian officials, along with many deterrence optimists, expected that overt nuclearization following the 1998 nuclear weapons tests would ensure stability in South Asia. The 1999 Kargil Conflict was an unpleasant confirmation that nuclear stability means different things to different people. India and Pakistan completely mobilized military forces beginning in December 2001, and did not de-mobilize until October 2002. During this period a war of words ensued that included a series of threats that included nuclear threats. India was poised on the brink of war, and many thought that some sort of

¹⁹⁶ Raghavan, "Limited War and Escalation in South Asia," 83.

¹⁹⁷ Michael Krepon and Chris Gagne, "Introduction," in *The Stability-Instability Paradox: Nuclear Weapons and Brinkmanship in South Asia* (Washington, D.C.: The Henry L. Stimson Center, June 2001), vii.

¹⁹⁸ Raghavan, "Limited War and Escalation in South Asia," 86.

military attack would soon follow. India's willingness to take steps to "punish" Pakistan for its alleged support of terrorism could effectively undermine the stability-instability paradox. However, since India did not follow up its words with military actions there may be those that believe that the stability-instability paradox is still a usable doctrine.

2. Crisis Instability in South Asia

Crisis instability is the opposite of crisis stability. It is based upon the fear of a surprise attack that threatens the nuclear deterrent, and undermines a stable nuclear deterrence.¹⁹⁹ A number of factors are at play in a crisis unstable environment, the most critical being the absence of one or more tenets of a stable nuclear deterrence. These tenets are: reliable nuclear weapons, secure second-strike capability, no possibility of pre-emption, and weapons are secure against unauthorized use. India and Pakistan do not appear to have fully developed the middle two tenets of a stable nuclear deterrence as discussed earlier. While both sides have tried to develop a secure second-strike capability, they may not be as survivable as required in light of the growing intelligence gathering and precision-strike capability. Pakistan in particular is handicapped by its lack of strategic depth and by India's growing capabilities. This leads to a growing concern that India may develop the capability to destroy Pakistan's nuclear capability in a pre-emptive attack, or at least the perception by Pakistan that it is attempting to gain a pre-emptive capacity.

Preparing for the possibility of being a victim of a first-strike, i.e. increasing readiness levels of strategic weapons, increasing alert posture, etc., can also be mistaken as preparing to launch a first-strike.²⁰⁰ The classical security dilemma comes into play, making any steps taken by a state to increase its security to be interpreted as an attempt to undermine the security of other states.²⁰¹ Crisis stability can build a great deal of

¹⁹⁹ Wirtz, "Beyond Bipolarity and Prospects for Nuclear Stability after the Cold War," 142.

²⁰⁰ Robert Jervis, *The Meaning of the Nuclear Revolution, Statecraft and the Prospect of Armageddon* (Ithaca: Cornell University Press, 1989), 138-145.

²⁰¹ Robert Jervis, "Cooperation Under the Security Dilemma," in *World Politics*, vol. 30, no. 2 (January 1978), 171.

confidence that neither side will attempt to engage in nuclear warfare, while crisis instability provides the opposite effect.

Posen excluded the “occasional accidental conventional attacks on nuclear weapons” systems as part of the friction of war as well as the “deliberate and sustained attack on nuclear weapons” systems that were designed to alter the balance of forces as being deliberately provocative.²⁰² There is a tremendous difference between incidental attacks and deliberate sustained attacks. The occasional attack, while potentially damaging, should not change the strategic picture. However, a well-coordinated conventional attack using good intelligence and precision-guided weapons has the potential to undermine the strategic forces of the targeted country. Such an attack has the potential to change the strategic balance, and would therefore add a totally different dynamic to any conflict. Recognition of crisis instability in South Asia will lead India and Pakistan to take steps to ensure the security of their strategic forces.

3. Future Changes in Force Structure and Doctrine

All three scenarios discussed in this thesis give rise to the potential for both deliberate and inadvertent escalation. Deliberately escalating and crossing the nuclear threshold is a profound yet deliberate choice. However, inadvertent escalation, while just as profound, can be an unforeseen consequence of the opponent’s actions. Studying the three situations yields a number of elements that are destabilizing, and perhaps preventable. Small arsenals lead to a degree of vulnerability, command and control is vulnerable, and pre-emption may become a real possibility. Each situation has a possible short-term solution in terms of force structure and nuclear doctrine that increases the likelihood of nuclear war. These are an arms race, pre-delegation of nuclear release authority, or a launch-on-warning posture.

Will India and Pakistan engage in an arms race with a goal of building up their respective strategic arsenals to provide a hedge against vulnerability? Both states are currently expanding and modernizing their strategic forces, especially the delivery systems. Pakistan will be under greater pressure to strengthen its strategic arsenal as the

²⁰² Posen, *Inadvertent Escalation*, 2.

conventional balance continues to tilt in India's favor. India may feel the need to expand its strategic arsenal to meet its goal of being a major regional power. The history of tit-for-tat actions in South Asia seems to indicate that these actions will spiral upwards in an arms race of sorts, but not at superpower levels due to economic considerations. Both states may feel the need to resume nuclear weapons testing to reinforce perceptions of strength and resolve. An arms race in South Asia would be particularly de-stabilizing to Pakistan due to its already weak economy.

What will Pakistan do to ensure the effectiveness and safety of strategic command and control structures? Pakistan's nuclear release authority is centered on a small cadre of decision makers who may be more vulnerable than the strategic command and control structure itself. The only quick fix to threats to the current command and control structure, either physical infrastructure or personnel related, would be to pre-delegate launch authority to subordinate commanders. This strategy would ensure that if Pakistan's "red-lines" were crossed that the launching of nuclear weapons would surely follow, and thus could serve as an effective deterrent. This would increase the risks of inadvertent escalation, not diminish it. Building a robust and redundant strategic command and control infrastructure is the only practical long-term solution, but may be out of Pakistan's reach in the short-term.

Will Pakistan adopt a launch-on-warning posture to guard against pre-emption? India's growing advanced conventional capabilities; based upon increased intelligence gathering and targeting capability and precision munitions, may hold Pakistan's small strategic forces at risk. India's defensive capabilities against air and ballistic missile attack will continue to grow. Pakistan's fears of a pre-emptive or decapitating first strike may grow as well, even though India's defense systems cannot provide a complete defense. Pakistan must therefore factor any conventional air attack, or perhaps ballistic missile launch, as a possible strike upon its retaliatory capability. Pakistan may feel that its only recourse is to adopt a launch-on-warning posture to guard against pre-emption. This will increase the risk of inadvertent escalation.

C. U.S. POLICY

India and Pakistan's relations continued to deteriorate following the terrorist attack on the Indian Parliament on 13 December 2001. Forces were mobilized along the border, leading to a tense military standoff. Intense pressure was put on the Indian government to conduct retaliatory attacks against Pakistan. The situation only began to de-escalate following the direct intervention of the United States and other concerned nations. Forces were finally withdrawn from the border in October 2002. The crisis was only the most recent of a number of such crises between India and Pakistan that have had the potential to escalate to the use of nuclear weapons. As dangerous and as devastating as the deliberate use of nuclear weapons would be, of even greater concern is that asymmetries of doctrine, conventional and strategic forces, and command and control could lead to inadvertent nuclear escalation.

1. U.S. Security Concerns

Inadvertent nuclear escalation between India and Pakistan threatens several U.S. security interests. Escalation between India and Pakistan would be devastating not only to Indians and Pakistanis but also to U.S. efforts to stabilize the region after the war in Afghanistan. The 1998 nuclear weapons tests were a blow to global nuclear nonproliferation efforts; the use of nuclear weapons would further undermine the nonproliferation regimes. The use of nuclear weapons as a warfighting tool ultimately could serve as an incentive for other nations, particularly those that are already pariah states, to continue to develop nuclear weapons. This would be a direct threat to U.S. interests, and significantly complicate U.S. efforts to deter regional aggression, WMD use, and even terrorism. The casualties caused by a major nuclear exchange would be a humanitarian, economic, and ecological disaster.

2. U.S. Role in South Asia

The U.S. military can help reduce tensions in the region by providing an environment that fosters cooperation and reduces the threat of inadvertent escalation. The rapidly improving U.S.-India defense relationship and Pakistan's assistance in the

U.S. war effort provide an opportunity to convey U.S. concerns. The United State's influence with each country's political and defense establishment has improved considerably in recent years, providing some leverage in the region. The U.S. Department of Defense (DoD) can play an important role in managing crises should they arise. Three mutually supporting engagement roles are proposed for consideration. These engagement roles are focused on measures to keep the peace, maintain the military balance, and moving the peace process forward.

The single most important step to preventing nuclear war in South Asia is to keep the peace between India and Pakistan. The U.S. should take concrete steps to encourage Indian restraint in Kashmir and to pursue a political process in Indian-held Kashmir. The U.S. should caution Pakistan against supporting militants in Kashmir and encourage Pakistan to accept a political process there. Both India and Pakistan should be encouraged to reduce tensions, particularly in Kashmir. Encourage India and Pakistan to resolve other outstanding differences (water rights, economic zones of interest, etc.). The United States could help India and Pakistan negotiate bilateral arrangements for the disputed border areas that include information sharing, joint patrolling, and hot pursuit.

Maintaining the regional balance is imperative. The United States should help stabilize conventional and nuclear deterrence in the region. Cooperative threat reduction has been successful in reducing the over-all threat of nuclear war; the program should be extended to include India and Pakistan, taking into account the unique characteristics of the respective programs. The U.S. can help ensure that nuclear weapons are secure against unauthorized use by providing technical training and assistance on security issues and negative control measures. Technical training and assistance to ensure robust and redundant C4I are emplaced for strategic weapons systems could also be provided. A hotline between the respective heads of state to ensure direct communication in times of crisis should be emplaced. The U.S. should take steps to ensure that de-stabilizing weapons systems (ABM, first-strike weapons, etc.) are not introduced into the region, and if they are, take steps to ensure that some degree of parity is maintained. Steps should be taken to ensure that Pakistan has adequate conventional defensive armaments, primarily focused on air defenses, so that it can move away from over-reliance on nuclear deterrence.

Finally, the United States should take steps to move the processes forward so that a permanent peace could be established in South Asia. The United States should help develop a regional security cooperation strategy through the development of a “South Asia” engagement strategy to promote regional stability, provide direction to the rapidly evolving U.S.-India and U.S.-Pakistan defense relationship, and ultimately lead to Indo-Pakistani cooperation. Both states are important to the United States geopolitically, (as partners in dealing with China, Central Asia, or the Persian Gulf), militarily, (combating terrorism and in keeping regional sea lines of communication (SLOCs) open), while India is important economically (for trade and investment), and politically (as the world’s largest democracy). This strategy should include three elements. First, the United States should pursue a long-term security relationship with both India and Pakistan, and recognize that security cooperation with both is critical to regional stability. Second, the United States must make both India and Pakistan aware that they have a joint responsibility to ensure peace in South Asia, and emphasize war prevention in this strategy. Finally, the United States should help forge a common understanding between the two states on regional security issues and begin taking constructive steps towards cooperation.

The United States should accelerate U.S.-India and U.S.-Pakistan military training and exercises. One method is to continue to promote counter-terrorism training and cooperation, which is equally important to all parties. U.S.-India and U.S.-Pakistan military exercises that demonstrate the risks and futility of escalation could be conducted. Efforts should be made toward conducting a U.S.-India, and U.S.-Pakistan naval exercise in defending SLOC access. The United States should make an effort to promote military interoperability in the event of a military contingency in the Persian Gulf or Central Asia.

The United States should seek to establish close personal ties with defense officials. The new climate of cooperation enables U.S. Department of Defense (DoD) officials and uniformed personnel to develop closer working relationships with their Indian and Pakistani counterparts after years of misunderstanding and mistrust between the respective militaries. Routine talking points should include: Encourage Indian restraint in Kashmir to pursue a political process in Indian-held Kashmir. Caution Pakistan against supporting militants in Kashmir and encourage them to accept a political

process there. Encourage India and Pakistan to reduce tensions, particularly in Kashmir. Encourage India and Pakistan to resolve other outstanding differences (water rights, economic zones of interest, etc.). The goal should be to try to develop a common strategic understanding with counterparts on South Asia, Central Asia, the Persian Gulf, and China. Major emphasis should be made of the value that the U.S. places on good relations with both India and Pakistan, and on reducing regional tensions.

Another area with potential is the promotion of professional military education and exchanges. This will pay huge dividends in the long term as more Indians and Pakistanis understand our political and military systems and more Americans understand theirs. The United States should try to develop a common strategic understanding with counterparts on South Asia, Central Asia, the Persian Gulf, and China. Opportunities for India and Pakistani military officers and defense officials to attend the Asia-Pacific Center for Security Studies (APCSS) or universities such as the Naval Postgraduate School (NPS) could be offered. An exchange program with Indian and Pakistani military officers attending U.S. professional military education institutions such as Command and General Staff College and the War College and sending U.S. officers to service equivalents in India and Pakistan could be established. Also, in-country training sites in all three states could be established so officers can become familiar with language, customs, and culture so that they can facilitate increased military to military contact.

D. FINAL WORDS

India and Pakistan must find ways to solve their problems. Each side must realize that the nuclearization of South Asia has raised the stakes and that any conflict has the potential to lead to nuclear war. The risk of conventional war in South Asia is high, and so is the risk of inadvertent escalation to nuclear war. Steps must be taken to ensure that India and Pakistan do not become embroiled in a war, even if the military actions are limited. The United States can play a constructive role in the region by taking steps to help keep the peace, maintain the military balance, and move the peace process forward.

THIS PAGE INTENTIONALLY LEFT BLANK

LIST OF ABBREVIATIONS

ABM	Anti-Ballistic Missile
APCSS	Asia-Pacific Center for Security Studies
ATV	Advanced Technology Vehicle
CEP	Circular Error Probability
COAS	Chief of Army Staff
COSC	Chiefs of Staff Committee
C3	Command, Control, and Communications
C4I	Command, Control, Communications, Computers, and Intelligence
DCC	Development and Control Committee
DoD	Department of Defense
ECC	Employment Control Committee
GDP	Gross Domestic Product
HEU	Highly Enriched Uranium
IAF	Indian Air Force
ICBM	Intercontinental Ballistic Missile
ISR	Intelligence, Surveillance, and Reconnaissance
kt	Kiloton
LOC	Line of Control
MRBM	Medium-range Ballistic Missile
NATO	North Atlantic Treaty Organization
NCP	National Command Post
NSAB	National Security Advisory Board
NPS	Naval Postgraduate School
NSC	National Security Council
RAPID	Reinforced Army Plains Division
PAF	Pakistan Air Force
PAL	Permissive Action Link
SAM	Surface-to-air missile
SLBM	Submarine Launched Ballistic Missile

SLOC	Sea Lines of Communication
SNC	Strategic Nuclear Command
SPD	Strategic Plans Division
SRBM	Short-range Ballistic Missile
TEL	Transporter Erector Launcher
UAV	Unmanned Aerial Vehicle
UCAV	Unmanned Combat Aerial Vehicles

BIBLIOGRAPHY

“ADE Kapothaka,” in *Jane’s Unmanned Aerial Vehicles and Targets*, no. 18, ed. Kenneth Munson (Coulson, UK: Jane’s Information Group, 2002).

“ADE Nishant,” in *Jane’s Unmanned Aerial Vehicles and Targets*, no. 18, ed. Kenneth Munson (Coulson, UK: Jane’s Information Group, 2002).

“Agni I/II/III,” in *Jane’s Strategic Weapon Systems*, no 37, ed. Duncan Lennox (Coulson, UK: Jane’s Information Group, 2002).

“Agreement between India and Pakistan on prevention of air space violations and for permitting over Flights and landings by Military Aircraft,” 6 April 1991, at <http://www.indianembassy.org/South_Asia/Pakistan/Airspace_Violations_Agreement_April_6_1991.html>.

Ahmed, Firdaus, “The Need to Revisit Conventional Doctrine,” 11 August 2002, at <<http://www.ipcs.org/issues/800/816-ndi-firdaus.html>>.

Ahmed, Mutahir, “Missile Defense in South Asia: A Pakistani Perspective,” in *The Impact of U.S. Ballistic Missile Defenses on Southern Asia*, ed. Michael Krepon and Chris Gagne (Washington, D.C.: Henry L. Stimson Center, July 2002).

“Air Force, India,” in *Jane’s Sentinel Security Assessment South Asia*, no. 10 (31 May 2002), at <<http://online.janes.com/>>.

“Air Force, Pakistan,” in *Jane’s Sentinel Security Assessment, South Asia*, no. 10 (31 May 2002), at <<http://online.janes.com/>>.

“Akash” in *Jane’s Strategic Weapons Systems*, no. 37, ed. Duncan Lennox (Coulson, UK: Jane’s Information Group, 2002).

Albright, David, “India’s and Pakistan’s Fissile Material and Nuclear Weapons Inventories, end of 1999,” (Institute for Science and International Security, 11 October 2000), at <<http://www.isis-online.org/publications/southasia/stocks1000.html>>.

---. “The Shots Heard ‘Round the World,” in *Bulletin of the Atomic Scientists*, vol. 54, no. 4 (July/August 1998), at <<http://www.thebulletin.org/issues/1998/ja98/ja98albright.html>>.

“Analogue Code Encryption (ACE) Unit,” in *Jane’s Military Communication*, no. 23, ed. John Williamson (Coulson, UK: Jane’s Information Group, 2002).

“Army, India,” in *Jane’s Sentinel Security Assessment South Asia*, no. 10 (31 May 2002), at <<http://online.janes.com/>>.

“Army Radio Engineered Radio (AREN),” in *Jane’s C4I Systems*, no. 14, ed. Giles Ebbutt (Coulson, UK: Jane’s Information Group, 2002).

“Army, Pakistan,” in *Jane’s Sentinel Security Assessment, South Asia*, no. 10 (31 May 2002), at <<http://online.janes.com/>>.

“AS-14 ‘Kedge’ (KH-29)” in *Jane’s Air Launched Weapons*, no. 40, ed. Robert Hewson (Coulson, UK: Jane’s Information Group, 2002).

“AWC Bravo,” in *Jane’s Unmanned Aerial Vehicles and Targets*, no. 18, ed. Kenneth Munson (Coulson, UK: Jane’s Information Group, 2002).

“AWC Mk I and II,” in *Jane’s Unmanned Aerial Vehicles and Targets*, no. 18, ed. Kenneth Munson (Coulson, UK: Jane’s Information Group, 2002).

“AWC Vision I and II,” in *Jane’s Unmanned Aerial Vehicles and Targets*, no. 18, ed. Kenneth Munson (Coulson, UK: Jane’s Information Group, 2002).

“AZ 7308E Speech Encryption Unit,” in *Jane’s Military Communication*, no. 23, ed. John Williamson (Coulson, UK: Jane’s Information Group, 2002).

“AZ 9870E Applique,” in *Jane’s Military Communication*, no. 23, ed. John Williamson (Coulson, UK: Jane’s Information Group, 2002).

Badri-Maharaj, Sanjay, Dr., *Strategic Air Defenses in Nuclear South Asia*, 15 August 2002, at <<http://www.bharat-rakshak.com/IAF/Info/SAD.html>>.

Basrur, Rajesh, M., “Missile Defense and South Asia: An Indian Perspective,” in *The Impact of U.S. Ballistic Missile Defenses on Southern Asia*, ed. Michael Krepon and Chris Gagne (Washington, D.C.: Henry L. Stimson Center, July 2002).

Bedi, Rahul, “Start Date for Indian Strategic Nuclear Command,” *Jane’s Defense Weekly*, 22 May 2002, at <<http://www4.janes.com/search97>>.

---. “Technical and Cost Problems stall India’s LCA,” *Jane’s Defense Weekly* (2 April 2000).

Beg, Mirza Aslam, General, “Deterrence, Defense and Development,” *Defense Journal* (July 1999), at <http://www.defencejournal.com?jul99/deterrence.htm>>.

Biringer, Kent, L., “Missile Threat Reduction and Monitoring in South Asia,” in *The Stability-Instability Paradox: Nuclear Weapons and Brinkmanship in South Asia*, ed. Michael Krepon and Chris Gagne (Washington, D.C.: The Harry L. Stimson Center, June 2001).

Blair, Bruce G., *Strategic Command and Control: Redefining the Nuclear Threat* (Washington, D.C.: Brookings Institution, 1985).

---. Harold A. Feiveson, and Frank von Hippel, "Taking Nuclear Weapons Off Hair Trigger Alert," *Scientific American* (November 1997).

Blair, David, "Finger on Nuclear Button is Not Musharraf's," in *London Daily Telegraph*, 7 June 2002, at <<http://ebird.dtic.mil/Jun2002/e20020607finger.htm>>.

Bracken, Paul J., *The Command and Control of Nuclear Forces* (New Haven, Yale University Press, 1983).

Bowen, Clay P., and Daniel Wolven, "Command and Control Challenges in South Asia," *The Nonproliferation Review* (spring/summer 1999).

Brodie, Bernard, "Implications for Military Policy," in *The Absolute Weapon: Atomic Power and World Order*, ed. Bernard Brodie (New York: Harcourt, Brace, and Company, 1946).

---. *Escalation and the Nuclear Option* (Princeton: Princeton University Press, 1966).

Brugioni, Dino A., *Eyeball to Eyeball: The Inside Story of the Cuban Missile Crisis* (New York: Random House, 1990).

Carranza, Mario E., "An Impossible Game: Stable Nuclear Deterrence After the Indian and Pakistani Tests," *The Nonproliferation Review* (spring/summer 1989).

Chari, P.R., "India's Slow-Motion Nuclear Deployment," in *Proliferation Brief*, 7 September 2000, at <<http://www/ceip.org/files/nonprolif/templates/Publications.asp?p=8&PublicationID=437>>.

Cheema, Zafar Iqbal, "Pakistan's Nuclear Use Doctrine and Command and Control," in *Planning the Unthinkable: How New Powers Will Use Nuclear, Biological, and Chemical Weapons*, ed. Peter R. Lavoy, Scott D. Sagan, and James J. Wirtz (Ithaca: Cornell University Press, 2000).

CIA Documents on the Cuban Missile Crisis, 1962, ed. Mary S. McAuliffe, CIA History Staff (Washington, D.C.: CIA, 1992).

Cloughley, Brian, *A History of the Pakistan Army: Wars and Insurrections* (Oxford: Oxford University Press, 1999).

---. "Pakistan's Army Still an Army," *Asia-Pacific Defense Reporter* (April/May 2000).

Commercial Observation Satellites: At the Leading Edge of Global Transparency, ed. John C. Baker, Kevin M. O'Connell, and Ray A. Williams (Santa Monica: RAND and ANPRS, 2001).

Cordesman, Anthony H., "In India, Pakistan Face-Off, An Uneven Military Match," in *San Diego Union-Tribune* (9 June 2002).

---. *The Conventional Military Balance in India Pakistan and South Asia: A Comparative Summary of Military Expenditures; Manpower; Land; Air; and Naval Forces; and Arms Sales* (Center for Strategic and International Studies, 27 December 2001).

---. *Weapons of Mass Destruction in India and Pakistan* (Washington, D.C.: Center for Strategic and International Studies, 23 January 2001).

Cotta-Ramusino, Paolo and Maurizio Martellini, *Nuclear Safety, Nuclear Stability, and Nuclear Strategy in Pakistan: A concise report of a visit by Landau Network-Centro Volta* (Landau Network, 21 January 2002), at <<http://lxmi.mi.infn.it/~landnet/Doc/pakistan.pdf>>.

Crouch, J.D., *Briefing on the Nuclear Posture Review*, 9 January 2002, at <<http://usinfo.state.gov/topical/pol/arms/stories/review.htm>>.

"Dassault Mirage 2000," in *Jane's All the Worlds Aircraft 2002-2003*, ed. Paul Jackson (Coulson, UK: Jane's Information Group, 2002).

"DGMP Hud Hud I and II," in *Jane's Unmanned Aerial Vehicles and Targets*, no. 18, ed. Kenneth Munson (Coulson, UK: Jane's Information Group, 2002).

Diamond, Howard, "India Releases Nuclear Doctrine, Looks to Emulate P-5 Arsenal," *Arms Control Today* (July/August 1999).

"Executive Summary, Pakistan" in *Jane's Sentinel Security Assessment South Asia*, no. 10 (3 September 2002), 5, at <<http://online.janes.com/>>.

Farooq, Umer, "Pakistan Needs Up To 70 Nuclear Warheads," *Jane's Defense Weekly*, 10 June 1998, 3.

Farrer, Mark, "India Moving to Dominate Indian Ocean," *Asia-Pacific Defense Reporter* (June 2002).

Faruqi, Ahmad, "Military Scales Don't All Tip India's Way," *Defence Journal* (April 2002), at <<http://www.defencejournal.com/2002/april/military.htm>>.

FAS Military Analysis Network, *Operation Desert Storm*, 18 October 2002, at <http://www.fas.org/man/dod-101/ops/desert_storm.htm>.

Feaver, Peter D., *Guarding the Guardians: Civilian Control of Nuclear Weapons in the U.S.* (Ithaca: Cornell University Press, 1992).

Feinstein, Lee, "Avoiding Another Close Call in South Asia", in *Arms Control Today* (July/August 2002).

Final Report to Congress, *Conduct of the Persian Gulf War* (April 1992).

Fursenko, Aleksandr and Timothy Niftal, *One Hell of a Gamble: Khrushchev, Castro, and Kennedy, 1958-1964* (New York: W.W. Norton and Company, 1997).

Ganguly, Sumit, *Conflict Unending: India-Pakistan Tensions since 1947* (New York: Columbia University Press, 2001).

---. *The Origins of War in South Asia: Indo-Pakistani Conflicts Since 1947* (Boulder: Westview Press, 1994).

GAO, Operation Desert Storm, Evaluation of the Air Campaign, GA/NSIAD-97-134 (June 1997).

Ghosh, C.N., Application of Unmanned Combat Aerial Vehicles in Future Battles of the Subcontinent, 29 August 2002, at <<http://www.idsa-india.org/an-jly-9.01.htm>>.

Haggerty, Devin T., *The Consequences of Nuclear Proliferation: Lessons from South Asia*, (Cambridge, Mass: The MIT Press, 1998).

Halperin, Morton H., *Limited War in the Nuclear Age* (New York: John Wiley and Sons, 1963).

"Hatf 3," in *Jane's Strategic Weapons Systems*, no. 37, ed. Duncan Lennox (Coulson, UK: Jane's Information Group, 2002).

"Hatf 4," in *Jane's Strategic Weapons Systems*, no. 37, ed. Duncan Lennox (Coulson, UK: Jane's Information Group, 2002).

"Hatf 5," in *Jane's Strategic Weapons Systems*, no. 37, ed. Duncan Lennox (Coulson, UK: Jane's Information Group, 2002).

Hatf 6," in *Jane's Strategic Weapons Systems*, no. 37, ed. Duncan Lennox (Coulson, UK: Jane's Information Group, 2002).

Hoyt, Timothy D., "Pakistani Nuclear Doctrine and the Dangers of Strategic Myopia," *Asian Survey*, vol. 41, no. 6 (November/December 2001).

Hussain, Jamal, Air Commodore (Retd), "Pakistan's Excellence in Air Combat: PAF's Forte," *Defence Journal*, April 2002, at <<http://defencejournal.com/2002/april/combat.htm>>.

"IAI Searcher," in *Jane's Unmanned Aerial Vehicles and Targets*, no. 18, ed. Kenneth Munson (Coulson, UK: Jane's Information Group, 2002).

"India Attacks Nuclear Blackmail," in *BBC News* (18 June 2002) at <http://news.bbc.co.uk/hi/english/world/south_asia/newsid_2051000/2051898.stm>.

"India buys Green Pine radars for missile defence," *Jane's Defense Weekly*, vol. 38 (10 July 2002).

"India's Nuclear Forces, 2002," in *Bulletin of the Atomic Scientists*, 28 August 2002, at <<http://www.thebulletin.org/issues/nukenotes/ma02nukenote.html>>.

International Institute for Strategic Studies *Strategic Survey 2002/2001* (London: Oxford University Press, 2001).

Jervis, Robert, "Cooperation Under the Security Dilemma," in *World Politics*, vol. 30, no. 2 (January 1978).

---. *The Meaning of the Nuclear Revolution, Statecraft and the Prospect of Armageddon* (Ithaca: Cornell University Press, 1989).

Jones, Rodney W., *Force Modernization Trends-India and Pakistan* (Policy Architects International, 23-25 October 2001), at <http://www.policyarchitects.org/pdf/ForceModern_IndiaPakistan2.pdf>.

---. "India Exercises Military Muscle," in *Friday Times* (8 July 2001), at <<http://www.thefridaytimes.com/news6.htm>>.

---. *Military Asymmetry and Instability in Emerging Nuclear States: India and Pakistan* (Policy Architects International, March 2002), at <http://www.policyarchitects.org/pdf/NucStability_IndiaPakistan1.pdf>.

---. *Minimum Nuclear Deterrence Postures in South Asia: An Overview* (Defense Threat Reduction Agency Advanced Systems and Concepts Office, 1 October 2001), at <http://www.dtra.mil/about/organization/south_asia.pdf>.

---. *Pakistan's Nuclear Posture: Quest for Assured Nuclear Deterrence-A Conjecture*, vol. 19 (Islamabad: Institute of Regional Studies, January 2002).

Kadian, Rajesh, "Nuclear Weapons and the Indian Armed Forces," in *Nuclear India in the Twenty-First Century*, ed. D.R. SarDesai and Raju G.C. Thomas (New York: Palgrave, 2002).

Kahn, Herman, *On Escalation: Metaphors and Scenarios* (New York: Frederick A. Praeger, 1965).

Kainikara, Sanu, "Indian Air Force: News Updates," *Asia-Pacific Defense Reporter* (February 2001).

Kampani, Gaurav, "India's Compellance Strategy: Calling Pakistan's Nuclear Bluff over Kashmir" (Monterey, Calif.: Center for Nonproliferation Studies, March 2002), at <<http://cns.miis.edu/pubs/week/020610.htm>>.

---. "Placing the Indo-Pakistani Standoff in Perspective," at *CNS Web Reports*, 8 April 2002, at <<http://cns.miis.edu/pubs/reports/pdfs/indopak.pdf>>.

Koch, Andrew, "India, Pakistan: Nuclear Arms Race Off to a Slow Start," *Jane's Intelligence Review* (1 January 2001).

---. "Pakistan Looks to USA to Fill UAV Gap," *Jane's Defense Weekly* (2 October 2002).

Krepon, Michael and Chris Gagne, "Introduction," in *The Stability-Instability Paradox: Nuclear Weapons and Brinkmanship in South Asia* (Washington, D.C.: The Henry L. Stimson Center, June 2001).

Krishna, Ashok, Major General, "Deployment of India's Armed Forces along the International Border (IB), the Line of Control (LoC) and at Sea," 8 July 2002, at <http://www.ipcs.org/issues/700/788-mi-krishna.html>>.

Lavoy, Peter R., "Fighting Terrorism and Avoiding War in South Asia: U.S. Relations with India and Pakistan after 11 September," forthcoming in *Joint Forces Quarterly*, Autumn 2002.

Lebow, Richard Ned, "Conclusions," in *Psychology and Deterrence*, ed. Robert Jervis, Richard Ned Lebow, and Janice Gross Stein (Baltimore: The John Hopkins University Press, 1985).

"Lockheed Martin F-16 Fighting Falcon," in *Jane's All the Worlds Aircraft 2002-2003*, ed. Paul Jackson (Coulson, UK: Jane's Information Group, 2002).

Malik, V.P. General, briefing, "Terrorism and Limited War with Kargil Backdrop," presented at National Defense University.

"Ministry of Defense," in *Global Security*, downloaded 2 November 2002, at <<http://www.globalsecurity.org/military/world/india.mod.htm>>.

"Mirage 2000," at *Bharat Rakshak* website, 15 August 2002, at <<http://www/bharat-rakshak.com/IAF/Info/Aircraft/Mirage-2000.html>>.

“Missile Armoury,” at *Bharat Rakshak* website, 15 August 2002, at <http://bharat-rakshak.com/IAF/Info/Missile.html>>.

“Mk P8 227 kg Bombs,” in *Jane’s Air Launched Weapons*, no. 40, ed. Robert Hewson (Coulson, UK: Jane’s Information Group, 2002).

“Mk 80 Series Bombs,” in *Jane’s Air Launched Weapons*, no. 40, ed. Robert Hewson (Coulson, UK: Jane’s Information Group, 2002).

“MOU Signed for LCA Production” in *Times of India* (7 June 2002) at <http://www.hinduonnet.com/thehindu/2002/06/07/stories/2002060702161200.htm>>.

“National Command Authority Established,” *Associated Press of Pakistan*, 3 February 2000, <http://www.fas.org/news/Pakistan/20000/000203-pak-app1.htm>>;

National Security Advisory Board on Nuclear Doctrine, *India’s Draft Nuclear Doctrine* (17 August 1999), at http://www.indianembassy.org/policy/CTBT/nuclear_doctrine_aug_17_1999.html>.

“NDC Vector,” in *Jane’s Unmanned Aerial Vehicles and Targets*, no. 18, ed. Kenneth Munson (Coulson, UK: Jane’s Information Group, 2002).

“New Indian 155 mm Self-Propelled Artillery System,” in *Jane’s Armour and Artillery*, no. 22, ed. Christopher F. Foss (Coulson, UK: Jane’s Information Group, 2002).

“Pakistan Develops Unmanned Aerial Vehicle,” in *Indian Strategic Review*, June 6, 2002, at <http://members.tripod.com/israindia/isr/june6/index.html>>.

Pakistan’s Ministry of Foreign Affairs, 13 November 2002, at <http://www.forisb.org/NCA.org>>.

“Pakistan’s Nuclear Forces, 2001,” in *Bulletin of the Atomic Scientists*, 6 July 2002, at <http://www.thebulletin.org/issues/nukenotes/jf02.nukenote.html>>.

“Pakistan to Acquire Anti-ballistic Missile System,” in *Defense Journal* (November 2002), at http://www.pakistaniddefense.com/news/FullNews/November2002/Pak-US_ABM.htm>.

Pandi, Rajat, “IAF Inducts Sukhoi-30MKI” in *Times of India* (28 September 2002).

Posen, Barry R., *Inadvertent Escalation* (Ithaca: Cornell University Press, 1989).

Pahwa, Pran Lieutenant General, *Command and Control of Indian Nuclear Forces* (New Delhi: United Service Institution of India, 2002).

“Prithvi (SS-150/-250/-350)(P-1/P-2/P-3) and Dhanush,” in *Jane’s Strategic Weapon Systems*, no. 37, ed. Duncan Lennox (Coulson, UK: Jane’s Information Group, 2002).

“PSD-1 and TSD-1 Hijara,” in *Jane’s Air Launched Weapons*, no. 40, ed. Robert Hewson (Coulson, UK: Jane’s Information Group, 2002).

Raghavan, V.R., “Limited War and Nuclear Escalation in South Asia,” *The Proliferation Review* (fall/winter 2001).

Rizvi, Gowher, “India, Pakistan, and the Kashmir Problem, 1947-1972,” in *Perspectives on Kashmir: The Roots of Conflict in South Asia*, ed. Raju G.C. Thomas (Boulder: Westview Press, 1992).

Rumsfield, Donald H., *Nuclear Posture Review Foreward*, 9 January 2002, at <http://www.defenselink.mil/news/Jan2002/d20020109npr.pdf>.

Sagan, Scott D. and Kenneth N. Waltz, *The Spread of Nuclear Weapons: A Debate* (New York: W.W. Norton and Company, 1995).

Santhanam, K., “Agni-1 and National Security,” 25 January 2002, at <http://idsa-india.org/agni-1250202.htm>.

Sawant, Gaurav C., “Smart Drones Silently Scan Enemy,” in *Indian Express*, 8 June 2002;

“SA-10/20 ‘Grumble’ (S300, S-300 PMU, Buk/Favorit/5V55/48N6),” in *Jane’s Strategic Weapons Systems*, no. 37, ed. Duncan Lennox (Coulson, UK: Jane’s Information Group, 2002).

Sehgal, Ikram, “India’s War Plan,” *Defense Journal* (January 2002), at <http://www.defensejournal.com/2002/january/war.htm>.

Sidhu, Waheguru Pal Singh, “India’s Nuclear Use Doctrine,” in *Planning the Unthinkable: How New Powers Will Use Nuclear, Biological, and Chemical Weapons*, ed. Peter R. Lavoy, Scott D. Sagan, and James J. Wirtz (Ithaca: Cornell University Press, 2000).

Singh, Satmir, Brigadier General, *Shaping the Battlefield Through Remote Sensing and Satellite Imagery*, 29 August 2002, at <http://www.idsa-india.org/an-feb00-5.html>.

Singhal, Arvind and Everret M. Rogers, *India’s Communication Revolution: From Bullock Carts to Cyber Marts* (New Delhi: Sage, 2001).

Smoke, Richard, *War: Controlling Escalation* (Cambridge, Mass.: Harvard University Press, 1977).

Solomon, Jay, “Indian President-Elect Kalam Says Nation’s Nuclear Arsenal is Secure,” in *Wall Street Journal* (22 July 2002), at <http://ebird.dtic.mil/Jul2002/e20020722indian.htm>.

South Asia Map, at <http://www.travelersdigest.com/south_asia_map.htm>, downloaded 2 December 2002.

“Strategic Forces Command on Anvil,” in *The Tribune*, 30 September 2002, at <http://www.tribuneindia.com/2002/20021001/main6.htm>.

“Strategic Nuclear Command Being Put in Place: Lt. Gen Joshi,” *Express India*, 30 September 2002, at <<http://www.expressindia.com/fullstory.php?newsid=15303>>.

“Sukhoi SU-30M,” in *Jane’s All the Worlds Aircraft 2002-2003*, ed. Paul Jackson (Coulson, UK: Jane’s Information Group, 2002).

“SU-30 Flanker,” at *Bharat Rakshak* website, 15 August 2002, at <<http://www.bharat-rakshak.com/IAF/Info/Aircraft/Su-30.html>>.

Tarr, David W., *Nuclear Deterrence and International Security: Alternative Nuclear Regimes* (New York, Longman, 1991).

Tellis, Ashley, *India’s Emerging Nuclear Posture: Between Recessed Deterrent and Ready Arsenal* (Santa Monica: RAND, 2000).

U.S. Department of Defense, *Findings of the United States Nuclear Posture Review*, 9 January 2002, at <<http://www.defenselink.mil/news/Jan2002/g020109-D-6570C.html>>.

Wagner, Alex, “India Test Short-Range Agni Ballistic Missile,” in *Arms Control Today*, March 2002, at <http://www.idsa.org/agni-1-250102.htm>.

Winner, Andrew C., and Toshi Yoshihara, *Nuclear Stability in South Asia* (The Institute for Foreign Policy Analysis, spring 2002), 37 at <<http://www.ifpa.org/pdfs/nssa.pdf>>.

Wirtz, James J., “Beyond Bipolarity: Prospects for Nuclear Stability after the Cold War,” in *The Absolute Weapon Revisited: Nuclear Arms and the Emerging International Order*, ed. T.V. Paul, Richard J. Harknett, and James J. Wirtz (Ann Arbor: University of Michigan Press, 1998).

World Factbook 2002, CIA, 18 October 2002, at <<http://www.cia.gov/cia/publications/factbook/geos/in.html#comm>>.

World Factbook 2002, CIA, 18 October 2002, at <<http://www.cia.gov/cia/publications/factbook/geos/pk.html#comm>>.

“124 kg and 250kg Prefragmented Bombs,” in *Jane’s Air Launched Weapons*, no. 40, ed. Robert Hewson (Coulson, UK: Jane’s Information Group, 2002).

INITIAL DISTRIBUTION LIST

1. Defense Technical Information Center
Ft. Belvoir, Virginia
2. Dudley Knox Library
Naval Postgraduate School
Monterey, California
3. Peter R. Lavoy
Naval Postgraduate School
Monterey, California
4. Surinder Rana
Naval Postgraduate School
Monterey, California
5. United States Ambassador to India
Shantipath, Chanakyapuri
New Delhi, India 11021
6. United States Ambassador to Pakistan
Ramna 5, Diplomatic Enclave
Islamabad, Pakistan
7. Dr. Rodney Jones
Policy Architects International
Reston, Virginia
8. Sharon Houy
Defense Intelligence Agency
Washington, D.C.