

February 2001

Mill Creek

Flood Control Project
Radial Gate Investigations

DISTRIBUTION STATEMENT A
Approved for Public Release
Distribution Unlimited

20030305 034



US Army Corps of Engineers, Walla Walla District

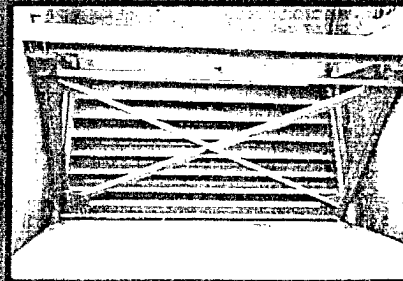
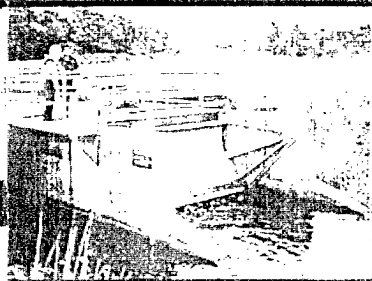

HDR Engineering, Inc.

REPORT DOCUMENTATION PAGE

*Form Approved
OMB No. 0704-0188*

Public reporting burden for this collection of information is estimated to average 1 hour per response, including the time for reviewing instructions, searching existing data sources, gathering and maintaining the data needed, and completing and reviewing the collection of information. Send comments regarding this burden estimate or any other aspect of this collection of information, including suggestions for reducing this burden, to Washington Headquarters Services, Directorate for Information Operations and Reports, 1215 Jefferson Davis Highway, Suite 1204, Arlington, VA 22202-4302, and to the Office of Management and Budget, Paperwork Reduction Project (0704-0188), Washington, DC 20503.

1. AGENCY USE ONLY (Leave blank)		2. REPORT DATE February 2001	3. REPORT TYPE AND DATES COVERED Inspection	
4. TITLE AND SUBTITLE Mill Creek Flood Control Project Radial Gate Investigations			5. FUNDING NUMBERS	
6. AUTHOR(S) HDR Engineering Inc. Wayne Edwards, P.E. Sam Planck, P.E.				
7. PERFORMING ORGANIZATION NAME(S) AND ADDRESS(ES) HDR Engineering Inc. 505 14th Street Suite 940 Oakland, CA. 94612			8. PERFORMING ORGANIZATION REPORT NUMBER	
9. SPONSORING/MONITORING AGENCY NAME(S) AND ADDRESS(ES) U.S. Army Corps of Engineers Northwestern Division Walla Walla District 201 North 3rd Avenue Walla Walla, WA. 99362-1876			10. SPONSORING/MONITORING AGENCY REPORT NUMBER	
11. SUPPLEMENTARY NOTES None				
12a. DISTRIBUTION AVAILABILITY STATEMENT DOD - Distribution Statement A. Approved for public release; distribution is unlimited.			12b. DISTRIBUTION CODE	
13. ABSTRACT (Maximum 200 words) This report is an evaluation of the overall condition of the spillway tainter gates at Mill Creek Flood Control Project, Walla Walla, Washington				
14. SUBJECT TERMS radial, gates, inspection, testing			15. NUMBER OF PAGES 145	
			16. PRICE CODE	
17. SECURITY CLASSIFICATION OF REPORT Unclassified	18. SECURITY CLASSIFICATION OF THIS PAGE Unclassified	19. SECURITY CLASSIFICATION OF ABSTRACT Unclassified	20. LIMITATION OF ABSTRACT UL	

AQU03-05-1170

MILL CREEK

Contents

MILL CREEK FLOOD CONTROL PROJECT RADIAL GATE INSPECTION AND TESTING	1 ✓
INTRODUCTION	1 ✓
Purpose	1
Scope of Inspection	1
Limitations	1
PROJECT BACKGROUND	2 ✓
6 ft. x 14 ft. (Armco) Radial Gate Inspection Observations	6 ✓
Member Section Dimensions.....	8
Radial Struts and Brace	8
Horizontal Girders	9
Skin Plate	9
Trunnion	10
Rivets and Connections	10
Hoist and Gate Operation Observations	10
8' x 18' Radial Gates General Inspection Observations	11 ✓
Member Section Dimensions.....	13
Radial Struts and Braces.....	13
Horizontal Girders	13
Rivets and Connections	15
Trunnion	15
Skin Plate	17
Side and Bottom Seals	19
Hoist and Gate Operation Observations	21
Individual Gate Observations	22
8 ft by 6 ft Sluice Gate (North Radial Gate) inspection observations	27 ✓
Member Section Dimensions.....	29
Radial Struts and Braces.....	29
Horizontal Girders	29
Rivets and Connections	29
Trunnion	31
Skin Plate	31
Side, Top and Bottom Seals.....	31
RECOMMENDATIONS	33 ✓
6 ft. x 14 ft. (Armco) Radial Gate:.....	33
8' x 18' Radial Gates:.....	33
8 ft by 6 ft Sluice Gate (North Radial Gate):.....	34
APPENDICES	
A – Inspection Sheets ✓	
B – Inspection Photographs	
C – As-built Drawings ✓	

MILL CREEK FLOOD CONTROL PROJECT RADIAL GATE INSPECTION AND TESTING

INTRODUCTION

Purpose

The Corps of Engineers, Walla Walla District, requires a comprehensive evaluation of the radial gates at the Mill Creek Flood Control Project. The District retained HDR Engineering, Inc. to perform inspection and testing of the radial gates through Task Order No. 5 under Contract DACW68-00-D-0001. The task order scope of work includes review of project information, an initial meeting and inspection, comprehensive field inspection of the radial gates, testing of gate hoist machinery, and preparation of a report.

Scope of Inspection

The scope of this inspection includes:

- Review of design, construction, maintenance and operations information provided by the District.
- Hands-on visual inspection of accessible upstream and downstream portions of six radial gates.
- Visual inspection of the hoists and hoist equipment.
- Observation and testing (where possible) of gates and hoists while operating.
- A report including documentation of the design and operation of the gates and hoists, inspection and testing results, conclusions and recommendations.

Limitations

The services under this contract include the professional opinion and judgment on the data and information reviewed. The conclusions and recommendations presented in this report are based on the information provided by the District and the inspection of the radial gates and hoists. The

inspection was visual only and only accessible portions of the components were inspected. No field or laboratory testing was performed in the course of the inspection.

PROJECT BACKGROUND

Project Description

The Mill Creek Flood Control Project is located three miles east of Walla Walla, Washington on Mill Creek, a tributary to the Walla Walla River. The project includes an off-stream earthfill storage dam, two concrete-lined outlet channels, a diversion dam, intake canal headworks to Mill Creek Lake and division works on Mill Creek with an intake to the Yellow Hawk - Garrison Canal. Construction of the project was completed in 1942.

The diversion dam is a 250-foot-long concrete ogee with a maximum height of 14 feet with the crest at Elev. 1261.0. The intake canal headworks is located at the south end of the diversion structure. The intake invert is at Elev. 1252.0.0 with four radial gates. The gates are 8-feet-high and 18-feet-wide. The intake gates are identified as Gate 1 on the East end and Gate 4 on the West end. There is an 8-feet-high by 6-feet-wide radial gate adjacent to Gate 1 that is used as a sluice gate. The sluice invert is at Elev. 1247.0.

The radial gate at the Yellow Hawk - Garrison Canal intake is 6-feet-high and 14-feet-wide and was installed in 1971 when the division works were modified.

The Standard Project Flood (SPF) is 11,300 cfs. The largest historical flood occurred on April 1, 1931 with an estimated peak discharge of 6,000 cfs. The flood on May 30, 1906 had an estimated peak discharge of 5,200 cfs. The project is designed to provide flood control by directing floodwaters above 1,400 cfs from Mill Creek to Mill Creek reservoir. From 1941 to 1991, 20 floods have occurred that would have required flood regulation under the current procedures.

Gate Design and Construction

The Corps of Engineers designed the gates and project facilities. The intake canal headworks gates and hoists were fabricated by Schmidt Steel Company of Portland, Oregon. Armco supplied the radial gate and hoist at the Yellow Hawk - Garrison Canal intake. The Walla Walla District provided copies of the engineering drawings and shop drawings for the gates. The gate and hoist specifications and calculations were not available. The following information was obtained from the documents.

8 ft by 18 ft Intake Gates

The structural steel for the gates is listed in the plans as Federal Specification QQ-S-721a. Records of this particular specification could not be found, however, the steel is believed to be type A7. The rivets are listed as Federal Specification QQ-S-721a Class C. The cast steel is Federal Specification QQ-S-681a Class I. The 3/8-inch skin plate is supported by eight 15-inch horizontal channels. The horizontal channels span between vertical end girders fabricated from 1/2-inch plates. Each end girder is supported by two gate arms made of two 4-inch by 4-inch angles. The gate arms are not braced in the vertical plane but have horizontal bracing.

Each trunnion has a 6-inch diameter steel pin with a bronze bushing. The trunnions rest on a 10-inch I-beam spanning between the piers. The trunnion support beams are anchored embedded in the piers and anchored with reinforcing rods.

The intake gates are each raised and lowered manually by a portable power driver. Wire ropes (5/8" diameter) on each side of the gate wind on separate drums mounted on a common shaft. This shaft is driven by the output shaft of the self-locking worm gear unit with a 30:1 ratio. The gates have a maximum discharge capacity of 7,000 cfs.

8 ft by 6 ft Sluice Gate (North Radial Gate)

The structural steel for the gates is listed in the plans as Federal Specification QQ-S-721a. Records of this particular specification could not be found, however, the steel is believed to be type A7. The 3/8-inch skin plate is supported by seven 8-inch channels. The channels span between vertical end girders made from 3/8-inch plate. Each end girder is supported by two gate arms made of two 4-inch by 4-inch angles. There is no vertical bracing on the gate arms but there is horizontal bracing. There is also a 3-inch by 3-inch angle between the trunnions.

Each trunnion has a 3-1/2 -inch diameter steel pin and a bronze bushing with a high pressure lubrication fitting. The trunnions bear directly on the concrete and are connected by embedded bolts.

The gate is raised and lowered manually with a portable engine drive. The maximum discharge capacity is 400 cfs.

6 ft by 14 ft Gate – Yellowhawk / Garrison Division

The gate is an Armco overflow type with a J-bulb bottom seal and rubber flap side seals. The hoist an Armco 4A type with a Limitorque SMB-000 operator. The trunnion pin is cast iron, 2-1/2 inches in diameter, embedded in the side walls of the gate structure. The radial struts are 2-1/2 inch by 2-1/2 inch angles, 1/4 inch thick. The top horizontal channel is 6 inches deep. The lower horizontal channels are 9 inches deep. Wire ropes on each side of the gate wind on separate drums mounted on a common shaft.

Gate Operation

Diversions to Mill Creek Lake for flood control begin when the Mill Creek flow exceeds 1,400 cfs at the project office gage (USGS gage No. 14015000). During major flood events, it may be necessary to increase the regulation objective to 3,500 cfs. When flows in Mill Creek are less than or equal to 400 cfs, the sluice gate at the diversion dam is operated as needed to maintain the water level in the forebay between Elev. 1253 and 1256.

Whenever the Mill Creek flow is 1,400 cfs or greater, the diversion dam intake gates are opened as necessary to regulate flow according to rule curves.

The Yellowhawk headwork gate diverts water from Mill Creek for irrigation. The gate is closed during flood operation.

Gate Maintenance

The District performs routinely inspects, tests, and lubricates the gates and hoists. Recent significant maintenance consists of:

- Intake gates and sluice gate – replaced J-bulb seals in 1984. And installed electrical heat trace to seals.
- The left trunnion pin on Gate 1 of the 8-ft x 18-ft intake gates was re-installed in 1999 after it was observed to have displaced beyond it's normal position.

Inspection Program

General

Wayne Edwards and Mike Haynes of HDR Engineering performed an initial site visit and inspection on April 5, 2000. Based on information collected during the initial inspection, HDR prepared an inspection plan and inspection sheets that were submitted to the District for review prior to the detailed inspection. The inspection of the radial gates was performed on September 19th, by Samuel M. Planck, P.E., and Tony Barela, of HDR Engineering, Inc. Marvin Brammer of HDR Engineering was also present during the inspections. Archie Milam performed mechanical observations. Mike Van Stone and Bob Radke (USACE) were present during the inspections and provided on site assistance. The weather was clear with temperatures ranging from 70 to 80 degrees F.

Procedures

The gates were inspected from the spillway apron and by climbing along the horizontal girders and radial struts. Where required, inspection rigging for the downstream inspections was anchored to the gate hoist equipment. Unless noted otherwise, all observations, and notes pertaining to the radial gates are identified as right or left looking downstream. Visual observations made for excessive sweep and camber of the main struts were recorded only if an abnormal condition was observed.

Measurements of the relative movement of the trunnion hub versus the trunnion yoke were not made at the three locations due to the following :

- 6-foot by 14-foot (Armco) gate: The trunnion consists of a 1/2-inch thick bushing rotating around a 2-1/2 inch diameter pin embedded in the pier. No part of the pin extended beyond the bushing, thus measurements for the upstream/downstream and vertical movements could not be made. At the time of the inspection, the gate was partially opened and water was flowing under the gate. There are no stoplogs or cofferdam for the site in order to dewater the gate, thus loaded versus unloaded measurements could not be made. Due to the water flowing under the gate, the channel sill was inaccessible as a reference and racking measurements could not be made.
- 8-foot by 18-foot radial gates: The water was below the spillway crest at this site and there was no means to load the gates in order to measure loaded versus unloaded movement of the trunnion. Racking measurements were recorded at all of the gates.
- 8-foot by 6-foot sluice gate (north radial gate): At the time of the inspection, the gate was partially opened and water was flowing under the gate. There are no stoplogs or cofferdam for the site in order to dewater the gate, thus loaded versus unloaded measurements could not be made. Due to the water flowing under the gate, the channel sill was inaccessible as a reference and racking measurements could not be made.

In the inspection sheets and this report, corrosion is classified as light, moderate or heavy as follows:

- Light - Surface rust with no flaking or packing. Rust can not be scraped off by hand.
- Moderate - Some flaking, beginning to pack, but thickness of the pack is less than approximately 1/16". There is no observable loss of section.
- Heavy - Pack rust with measurable or observable section loss to the member.

6 FT. X 14 FT. (ARMCO) RADIAL GATE INSPECTION OBSERVATIONS

The inspection of the gate was performed on September 19th, by Samuel M. Planck, P.E., and Tony Barela, of HDR Engineering, Inc. Marvin Brammer of HDR Engineering were present during the inspections. Archie Milam performed mechanical observations. The gate was open approximately six inches with water flowing beneath the gate during the inspection.

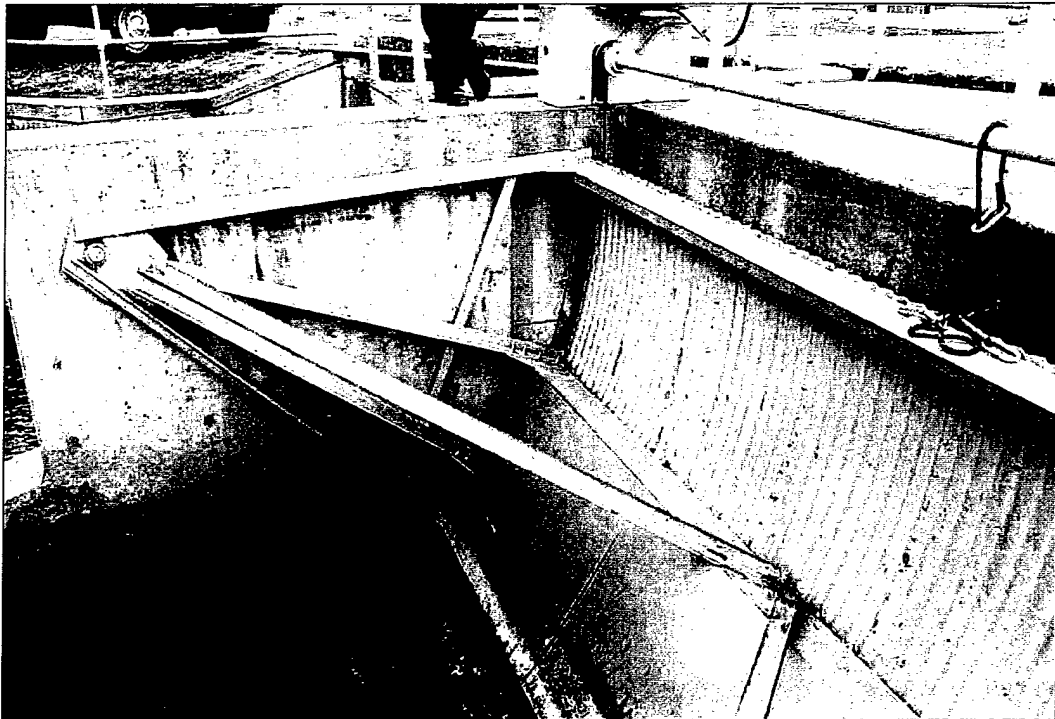

Photo 1- 6 ft. x 14 ft. Armco Gate

MILL CREEK

For the radial gate inspection observations and the photographs, the member designations indicated in Figures 1 and 2 apply.

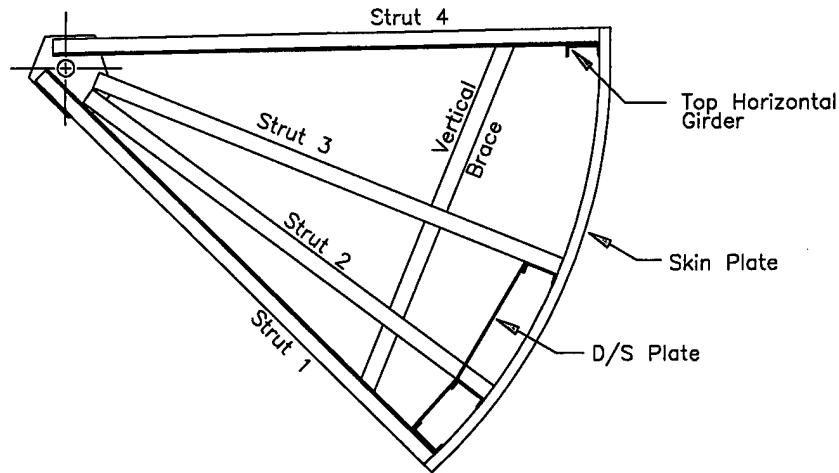

Figure 1 - 6 ft. x 14 ft. gate - Side Frame

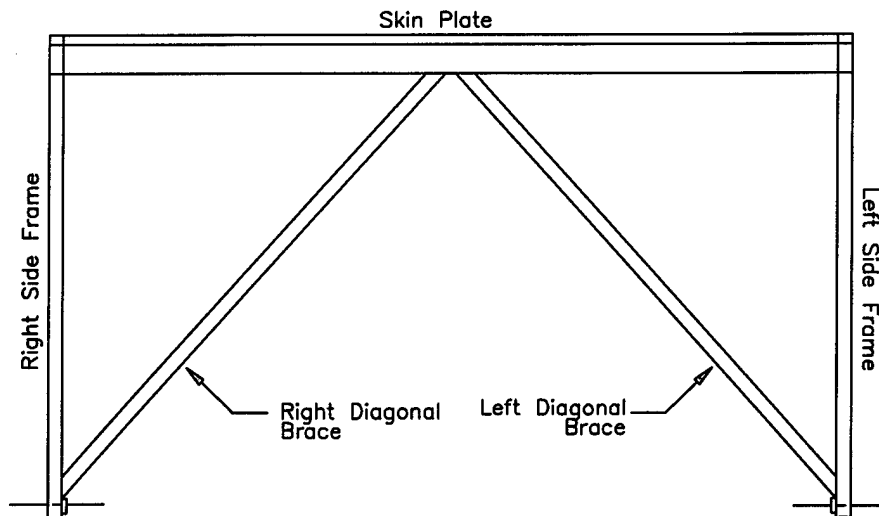

Figure 2 - 6 ft. x 14 ft. gate - Plan

Member Section Dimensions

Section dimensions of main structural members are typically measured to verify conformance with the design drawings. Since no as-built drawings or design information was available, no comparisons to the intended design could be made. The measured member section dimensions and the assumed member type are given in the individual component inspection observations below.

Radial Struts and Brace

The radial struts for the Armco gate consist of four 2-1/2 inch by 2-1/2 inch by 1/4 inch thick angles. The angles are braced vertically by a 2 inch by 1/2 inch bar. At the upstream end the struts are connected to the horizontal girders with 1/4 inch thick gusset plates. At the trunnions the struts are welded to a 1/2 plate which serves as both a gusset plate and connection to the trunnion bushing. The struts are in good condition with only isolated locations of delaminated paint and light surface corrosion. The vertical brace is also in good condition with similar spots of light corrosion and delaminated paint.



Photo 2 - Radial strut and diagonal brace connection to trunnion showing light corrosion.

Horizontal Girders

Based on the measured dimensions, the top horizontal girder (girder 4) is believed to be a C6 x 8.2. Horizontal girders 1, 2 and 3 (bottom 3 girders) are covered with an aluminum cover plate riveted to the girders and full section measurements were not able to be obtained. The depth of Horizontal Girder 3 was measured at 9 inches. Girders 1 and 2 appeared to be the same depth, although measurements could not be made. Horizontal Girder 1 and the top of Horizontal Girder 2 are in good condition with isolated spots of delaminated paint and light corrosion.

Skin Plate

The skin plate is comprised of three sections of corrugated, galvanized steel with the corrugated ribs running in the vertical direction. The plate is 3/32 inch thick, with a span between corrugations of 2-3/4 inches and a section depth of 3/4". The skin plate is in very good condition. There are spots of delaminated paint, however, very little corrosion is visible through the galvanizing.



Photo 3 - Downstream surface of skin plate showing typical worst case delamination.

Trunnion

The trunnion consists of a 2-1/2 pin contained by a 1/2 inch thick bushing. The bushing is welded directly to the 1/2 inch thick trunnion plate. All components of the trunnion are in good condition with only light surface corrosion at isolated locations.

Rivets and Connections

The bolted, welded and riveted (skin plate) connections on the gate were in very good condition with only isolated spots of light surface corrosion present.

Hoist and Gate Operation Observations

External portions of the hoist equipment, support platforms and gate connections were visually inspected for signs of excessive corrosion, wear or damage. The hoist and hoist machinery are in generally good condition. The gate was operated from the partially open position to the open position and appears to be operating smoothly.

8' X 18' RADIAL GATES GENERAL INSPECTION OBSERVATIONS

The inspection of the gate was performed on September 19th, by Samuel M. Planck, P.E., and Tony Barela, of HDR Engineering, Inc. Marvin Brammer of HDR Engineering was present during the inspections. Archie Milam performed mechanical observations. The gates were closed during the downstream inspection and opened approximately two feet to allow access under the gate for the upstream face inspection. The reservoir elevation was approximately two feet below the crest of the spillway. The observations below apply generally to gates 1 through 4. Observations or deficiencies specific to individual gates begin on page 10. Field inspection sheets for the gate are included in Appendix B.

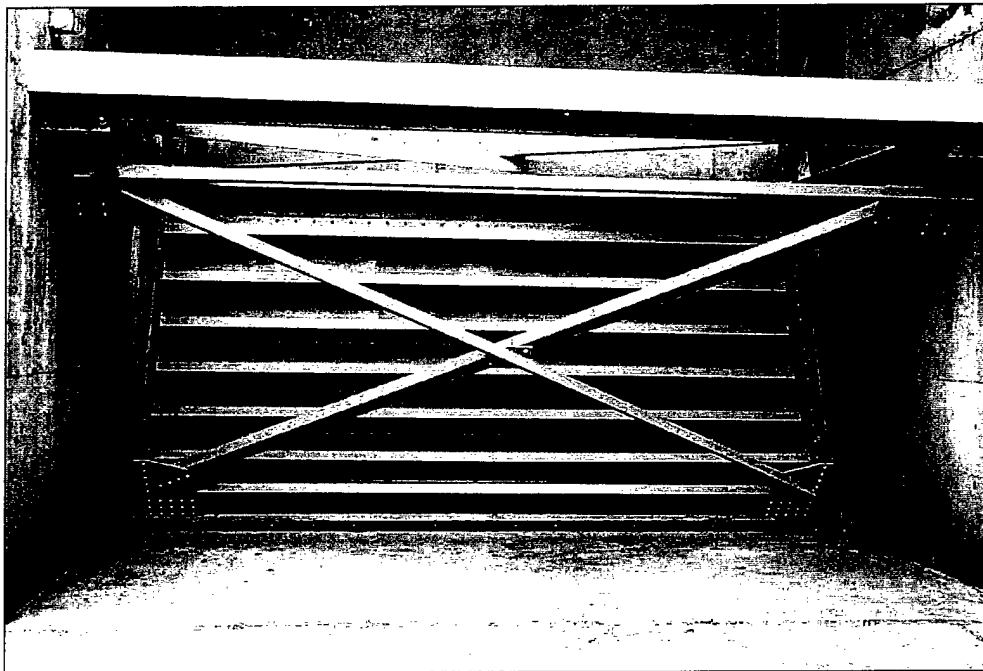

Photo 4 - 8 ft. x 18 ft. Radial Gate (typ).

MILL CREEK

For the radial gate inspection observations and the photographs, the member designations indicated in Figures 1 and 2 apply.

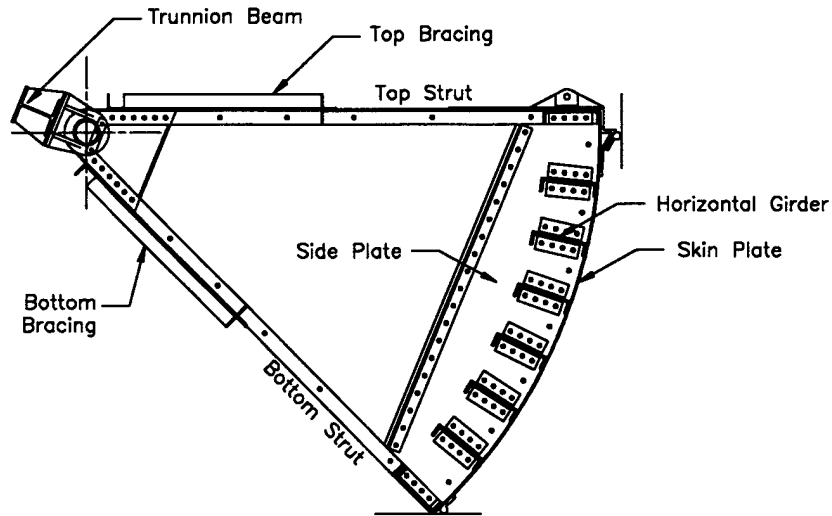

Figure 4 - 8 ft. x 18 ft. Radial Gate Side Frame

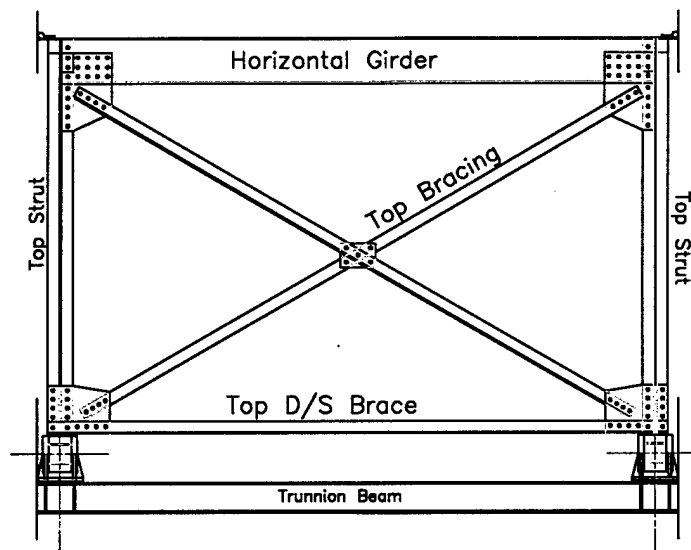

Figure 5 - 8 ft. x 18 ft. Radial Gate Top Plan

Member Section Dimensions

Section dimensions of main structural members were measured to verify conformance with the design drawings. These members included radial struts, top and bottom bracing, the side plate and the horizontal girders. Measured dimensions were recorded on inspection sheets found in Appendix B. The data sheets also contain nominal section dimensions from the American Institute of Steel Construction (AISC) *Manual of Steel Construction, Seventh Edition, 1970*. Section measurements typically include the depth, d (measured at the edges of the flanges), the flange width, b_f and the flange thickness, t_f . Web thickness, t_w , was only measured if there was an exposed portion of the web or drain holes large enough for calipers.

Differences between the design drawings and the actual field conditions of $1/16^{\text{th}}$ inch or less were deemed to be insignificant. All members in the field were found to be greater or equal in dimension than what was required in the design drawings. The larger dimensions were probably due to inaccuracies on the field measurements resulting from difficult access or with the thickness of the paint on the members.

Radial Struts and Braces

The radial struts for the 8 foot by 18 foot gates consist of back-to-back 4 inch by 4 inch by $3/8$ inch thick angles. The struts are in good condition with only isolated locations of delaminated paint and light surface corrosion. The riveted, gusset plate connections are in good condition, as are the connections to the trunnion. Top and bottom bracing is also comprised of 4 inch by 4 inch by $3/8$ inch thick angles. The bracing was also in good condition with only isolated locations of delaminated paint and light surface corrosion.

Horizontal Girders

The horizontal girders are C 15 x 40 channels spanning between the end plates at the side frames. The channels are riveted to the skin plate on the upstream flange and riveted the side plates with angle connections at the ends. The flanges of the channels are oriented downward, with the exception of the bottom channel, which has flanges oriented upward. The girders are in generally good condition with little corrosion present. There is evidence of standing water and clogged drain holes on the channels due to their radial orientation which can trap water between the web and the skin plate.

On the bottom horizontal girder there is a timber bumper bolted to the bottom side of the web. The plans indicate a 3-inch by 6-inch S4S fir bumper, fastened with $5/8$ -inch carriage bolts. The spacing of the carriage bolts is not indicated in the plans. There are holes through the web of the

MILL CREEK

channel at approximately 6-inches on-center, however, there are bolts at only every other hole. See photos 5 and 6, below. Note: The 6-inch spacing matches that of the connections to the skin plate. Since the spacing of the bolts is not indicated on the plans, it is not known if the holes were intended for bolts to fasten the bumper to the channel or if the holes are intended for drainage. The holes are not continued through the timber bumper and are consistently clogged with debris at the girder web.

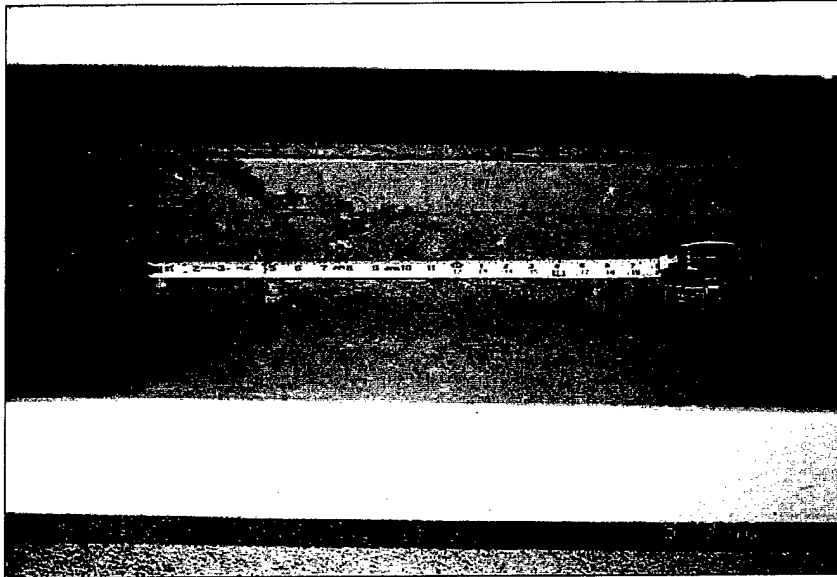

Photo 5- Debris and clogged holes on bottom channel (typ).

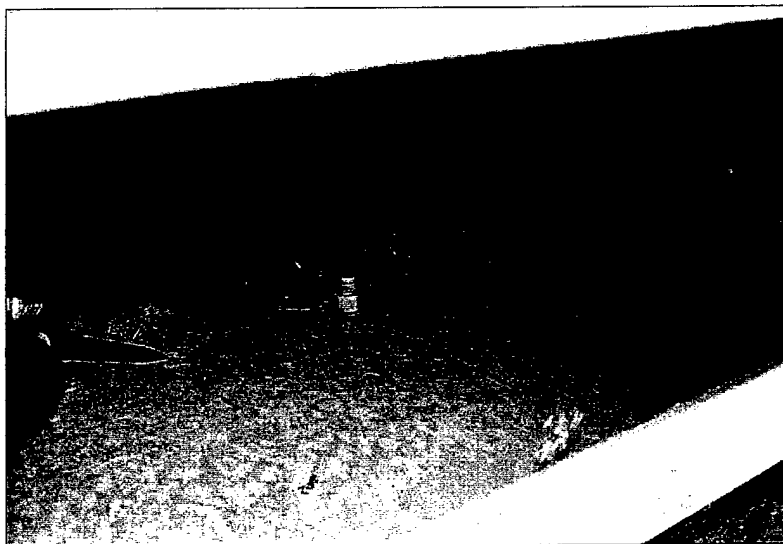

Photo 6- Debris and clogged holes on bottom channel (typ).

Rivets and Connections

All of the connections on the gate were in very good condition. Small amounts of rivet head loss due to corrosion were found at isolated locations, however, the rivets were in generally excellent condition.

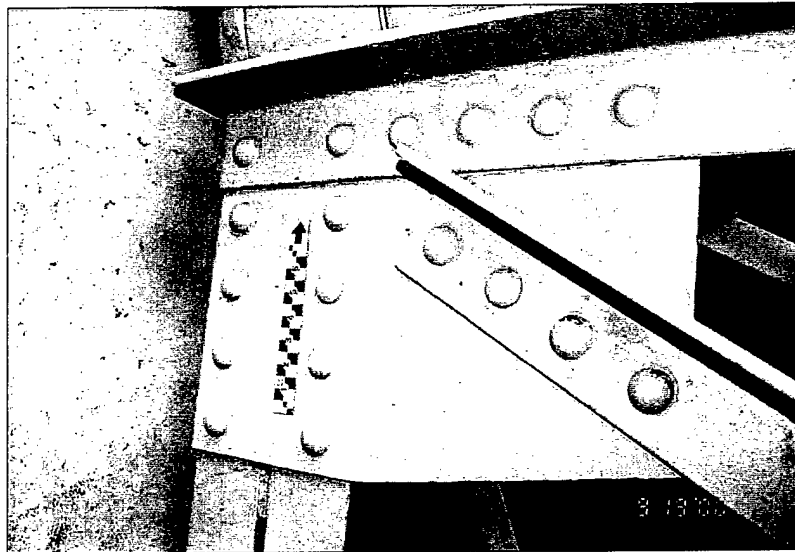

Photo 7 - Typical condition of rivets.

Trunnion

The trunnions at all of the gates are in generally good condition and appear well lubricated. There are isolated spots of light surface corrosion on the trunnion hub or yoke at some of the trunnions, however, no section loss is visible. Photo 8, below, shows the typical condition of the trunnions.

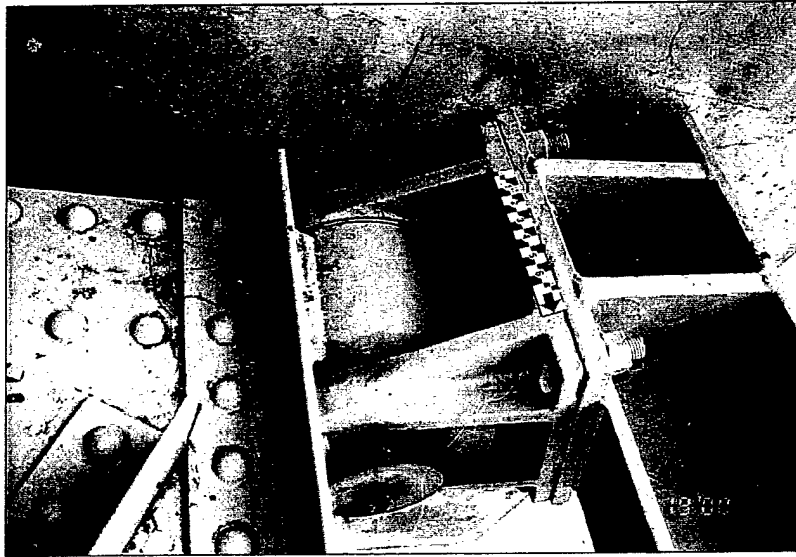

Photo 8 - Typical condition of trunnion.

The trunnion beam is a 10 WF 60 with the flanges oriented vertically and no drainage. There is evidence of standing water on the web, between the flanges, for this member at all of the gates. Light to moderate surface corrosion and cracked and delaminated paint is also evident on the member at all of the gates. See photo 9, below.

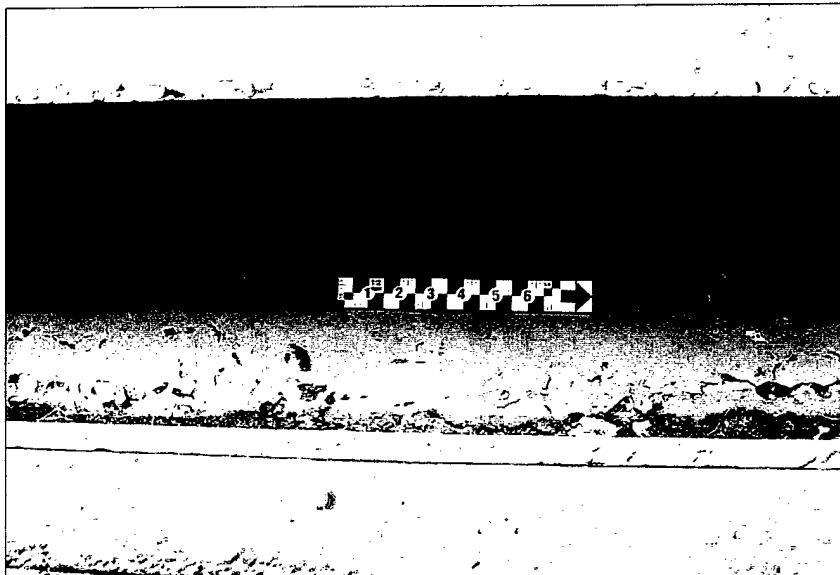

Photo 9 - General condition of trunnion beam, evidence of standing water, cracked and delaminated paint.

Skin Plate

The condition of the skin plate varied on each gate from generally good on the top six feet of the gate, to light to moderate corrosion on the bottom two feet. Small patches of paint delamination could be found at all heights on all of the gates, however, the majority of the corrosion occurred near the bottom of the gate. Photo 10 shows the general condition of the skin plate.

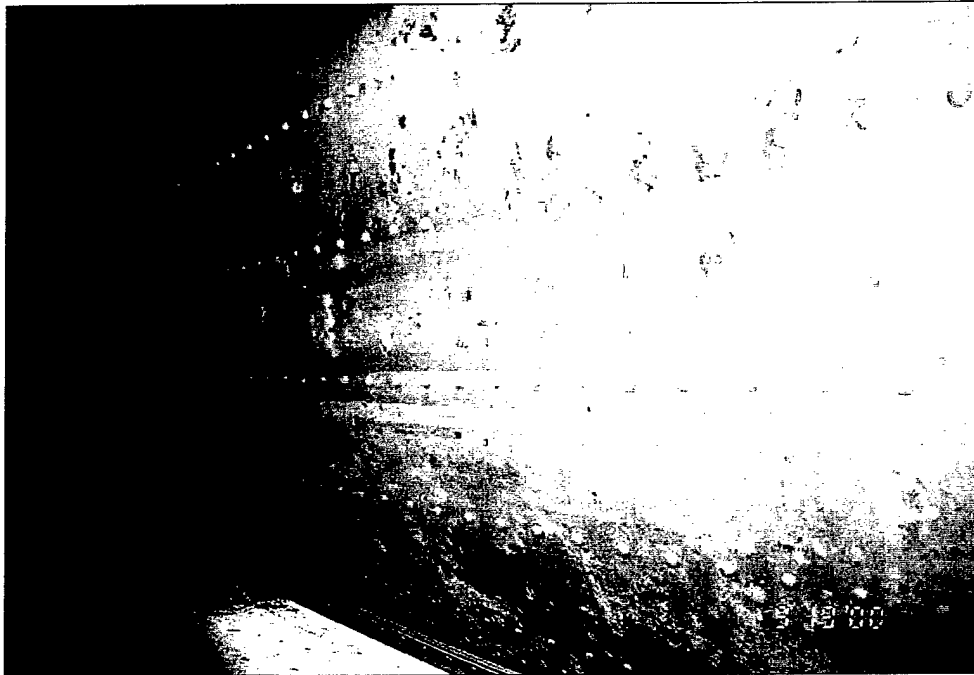

Photo 10 - Typical skin plate condition.

Photo 11 shows a close-up of the delaminated paint and moderate corrosion typical on the gate faces. Photo 12 shows a close-up of moderate corrosion near the bottom seal on Gate 2 (Note: good condition of rivets and bolts).

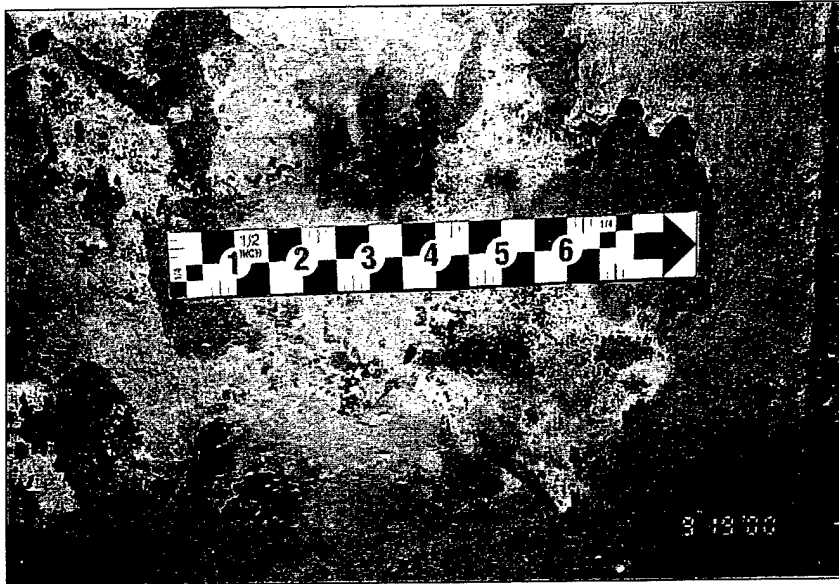

Photo 11 - Delaminated paint and light to moderate corrosion, typical on all gates.

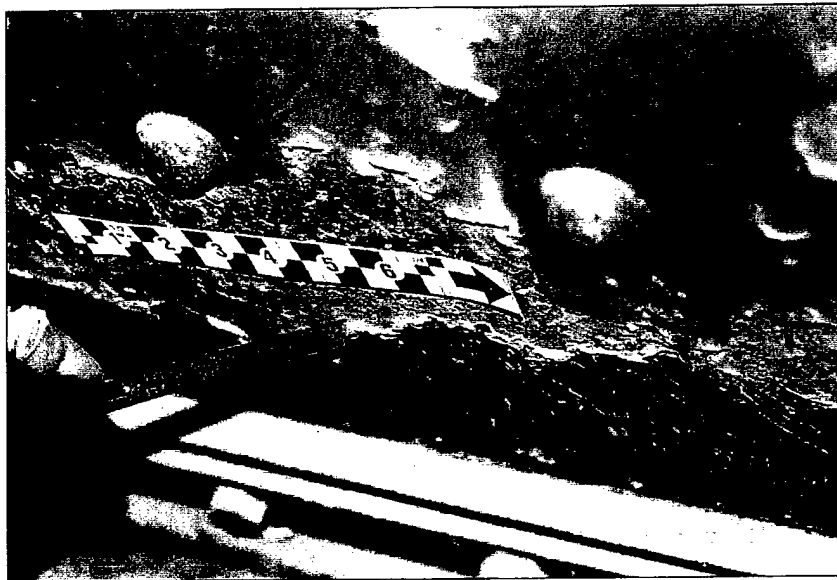

Photo 12 - Moderate corrosion on skin plate at bottom seal.

Side and Bottom Seals

The side and bottom seals are in good condition with only light cracking and deterioration evident. Due to the water level below the spillway, no determination of leakage was possible. There is no evidence of excessive corrosion on the members likely to be caused by side seal leaks.

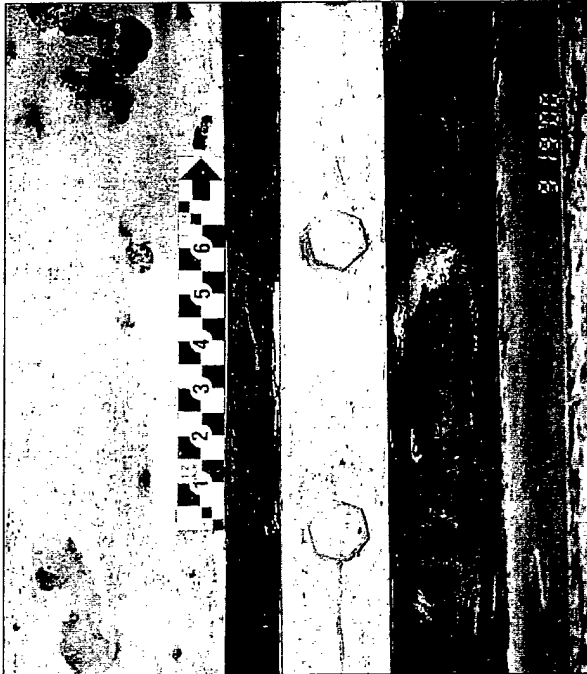

Photo 13 - Typical condition of side seal as seen from upstream side of gate.

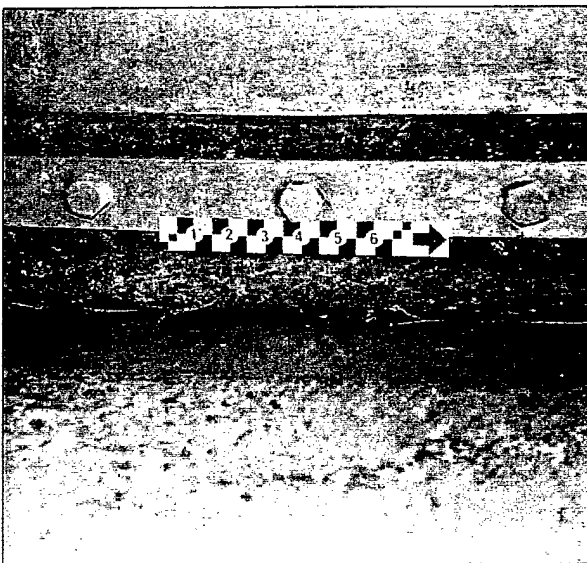

Photo 14 - Typical condition of bottom seal as seen from upstream side of gate.

MILL CREEK

Timber bumpers are installed at the bottom of the gate on the downstream side. The timbers are bolted to the web of the bottom horizontal girder. At all of the gates, on at least one end, the timbers are split or deteriorated. See photo 15 below, typical.

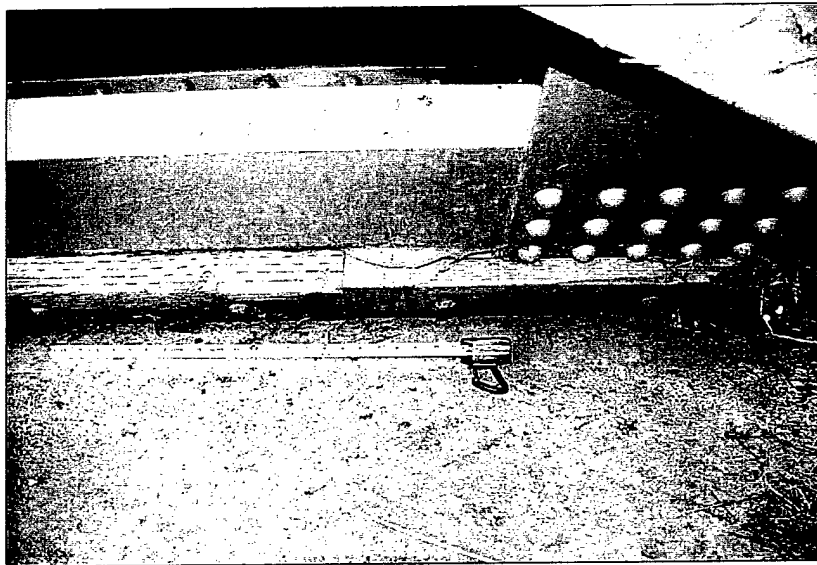

Photo 15 - Splitting of bottom timber at right side (looking upstream) of Gate 1.

Electric side seal heaters have been installed on the gates at some time in the past. None of the operations personnel present were aware of the presence of the heaters. No determination as to the working condition of the heaters was made. See photo 16, below

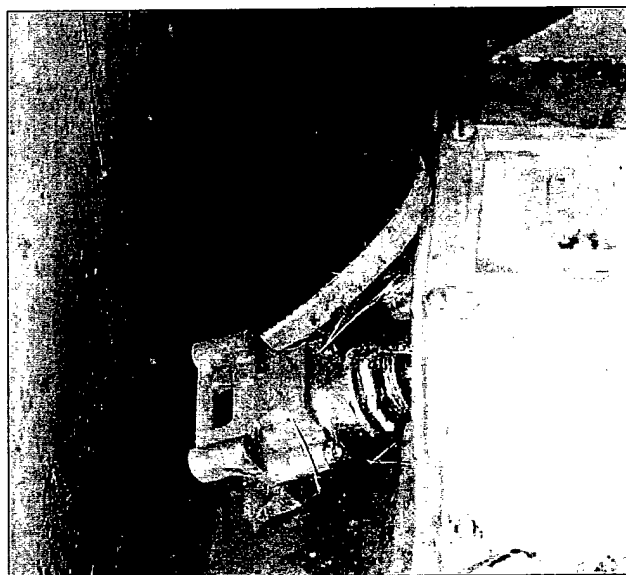

Photo 16 - Apparent side seal heater, typical all gates.

Hoist and Gate Operation Observations

External portions of the hoist equipment, support platforms and gate connections were visually inspected for signs of excessive corrosion, wear or damage. The hoist and hoist machinery are in generally good condition. All of the gates were raised to approximately two feet open in order to check for racking and to allow access to the upstream side. Racking measurements were made at the left and right side of the gates, between the bottom corner of the bottom horizontal girder and the top of the spillway. There is no apparent racking occurring at any of the gates and all measurements were within 1/8-inch from one side to the other. Measurements for each of the gates are given in Table 1, below. The 2:1 reduction, lifting pulleys on the top of the gates were in good condition with only light corrosion on some of the wheels or linkages. See photo 17 below.

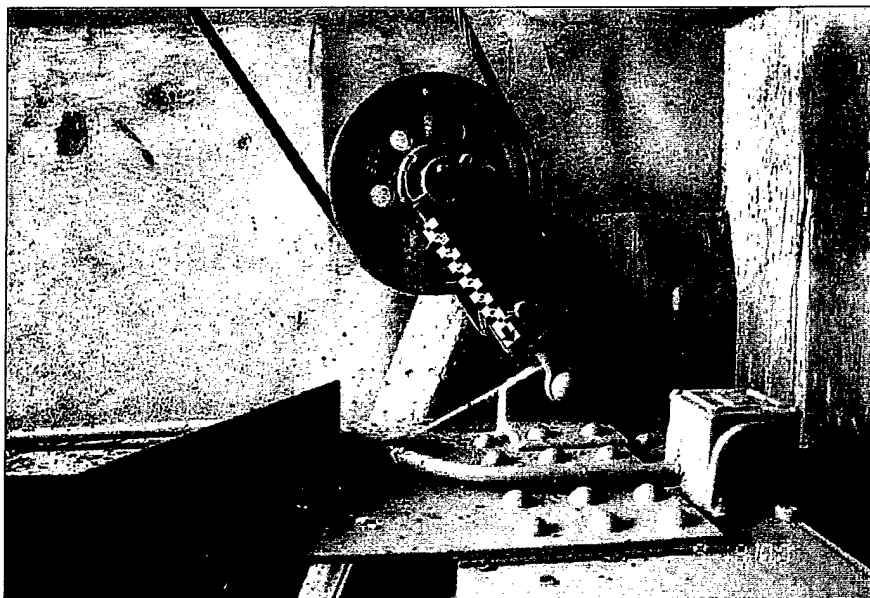

Photo 17 - Hoist reduction pulley at top of gate, typical.

Gate	Opening (in)	
	Left	Right
1	22 1/8	22 1/8
2	22 5/8	22 5/8
3	23 5/8	23 5/8
4	14	14 1/8

Table 1 - Racking Measurements.

Individual Gate Observations

The following observations apply only to the gate indicated.

Gate 1

- The bottom strut along the right frame at the bottom girder connection is moderately corroded and deformed. See photo 18.

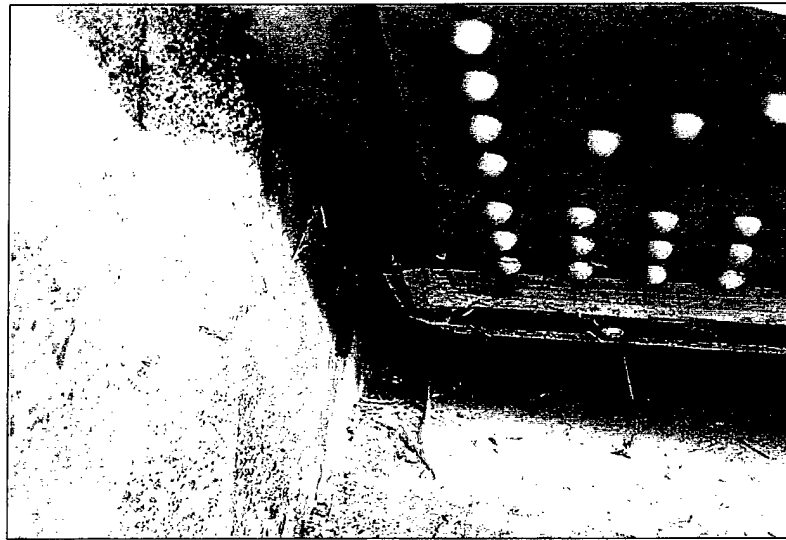

Photo 18 – Bottom strut, right frame at bottom girder connection. Bottom strut is deformed and wooden bumper cracked.

- During the operation of Gate 1 heavy vibration and scraping was observed beginning at an opening height of approximately one foot. Operation of the gate was discontinued at that point. The bottom bracing angles were observed to be vibrating significantly in the out-of-plane direction (approximately vertical).

- The gate is shifted significantly to the right (looking upstream). The left side frame appears to be in contact with the pier wall near the upstream end of the bottom radial strut, see photo 19. This condition is likely the cause of the vibration observed during operation.



Photo 19 - Left frame in contact with pier wall.

Gate 2

See general observations.

Gate 3

- There are two bolts missing between the top girder and the top seal. Some bolts appear to have been tack welded while others were not. One bolt was loose enough to turn by hand. See photo 20.

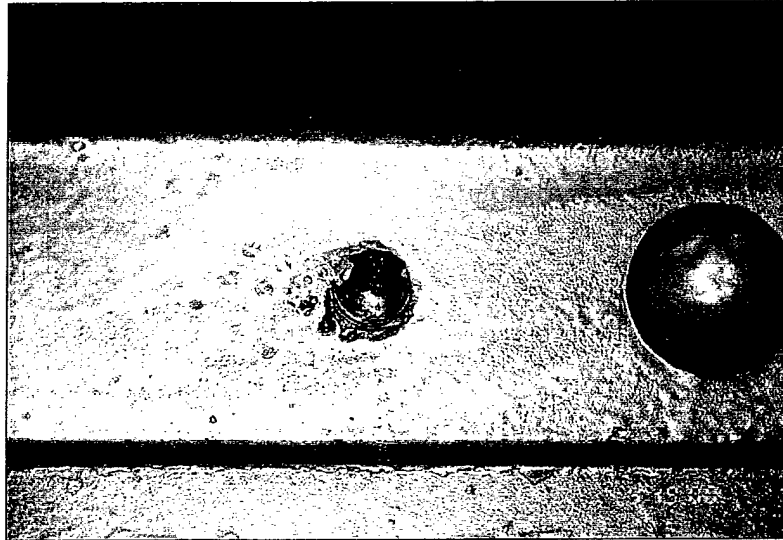

Photo 20 - Bolt at top girder to top seal. Note broken tack weld.

- Right side frame, bottom strut, inside angle. A punched hole in located just above rivet point. There is no evidence of additional stress or deformation due to the added hole. See photo 21.



Photo 21 - Punched hole in bottom strut, right frame.

Gate 4

- There are five missing bolts at the top of the gate. The bolts attach the upstream top seal bracket to the skin plate and the web of the top horizontal channel. There is no apparent distress or evidence of leakage due to the missing bolts. See photo 22 below.

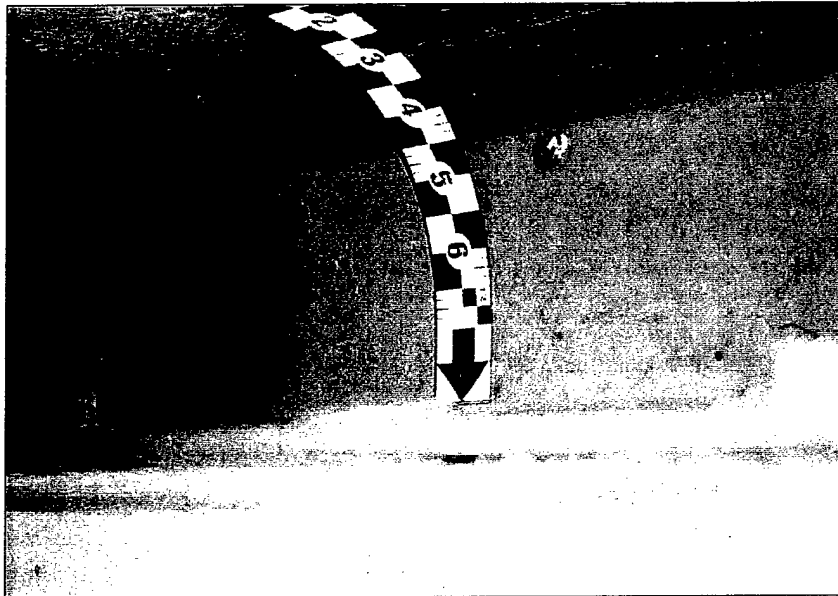

Photo 22 - Missing bolt at top seal bracket, typical of five locations. Note: presence of washer without bolt head.

MILL CREEK

- The entire gate is shifted significantly to the right (looking upstream). The left side frame is in contact with the pier wall near the upstream end of the bottom radial strut. Scraping and gouging of the concrete pier is evident at the bottom of the pier. See photo 23.



Photo 23 - Left frame in contact with pier wall. Note: small steel ruler in gap between radial strut brace and concrete pier wall.

8 FT BY 6 FT SLUICE GATE (NORTH RADIAL GATE) INSPECTION OBSERVATIONS

The inspection of the gate was performed on September 19th, by Samuel M. Planck, P.E., and Tony Barela, of HDR Engineering, Inc. Marvin Brammer of HDR Engineering was also present during the inspections. Archie Milam performed mechanical observations. The gate was open with water flowing through the sluice during the downstream inspection. Field inspection sheets for the gate are included in Appendix B.

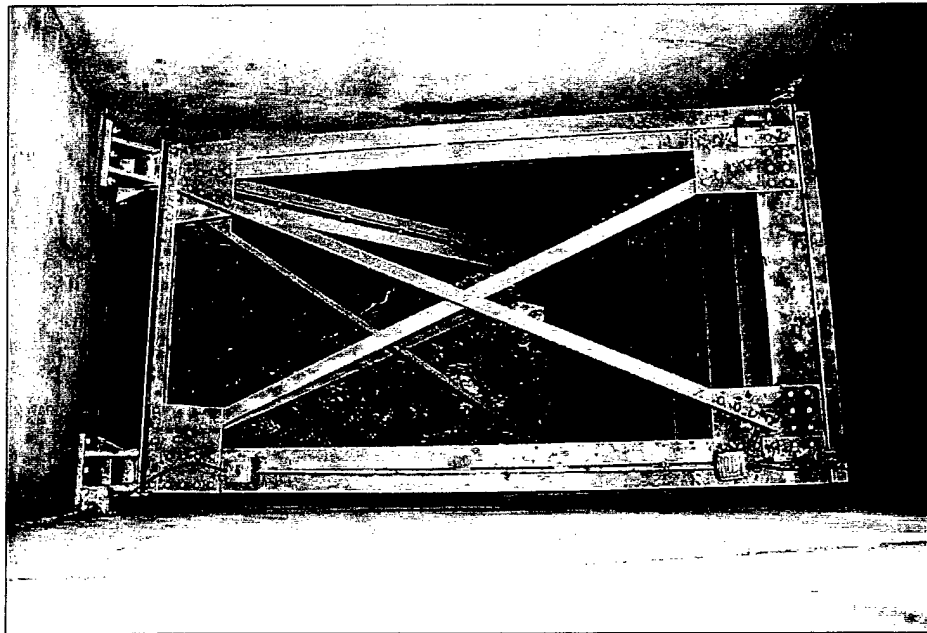

Photo 24 - 8 ft by 6 ft sluice gate (North Radial Gate)

For the radial gate inspection observations and the photographs, the member designations indicated in Figures 5 and 6 apply.

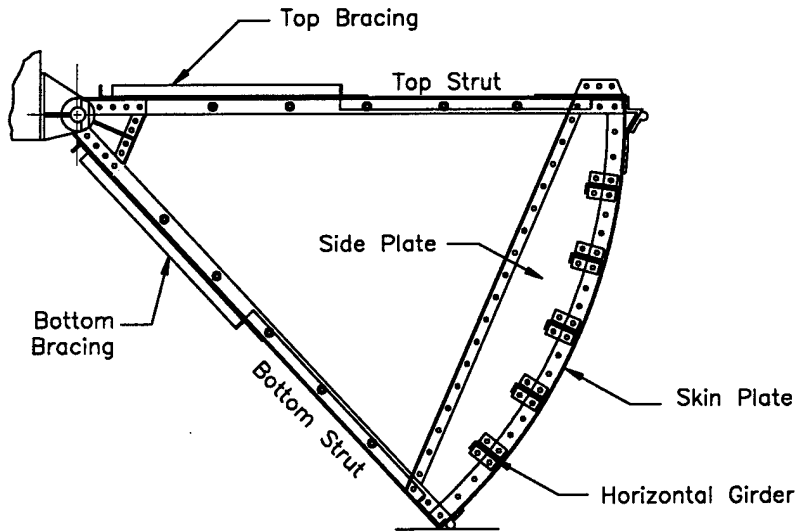

Figure 5 - 8 ft by 6 ft sluice gate side frame.

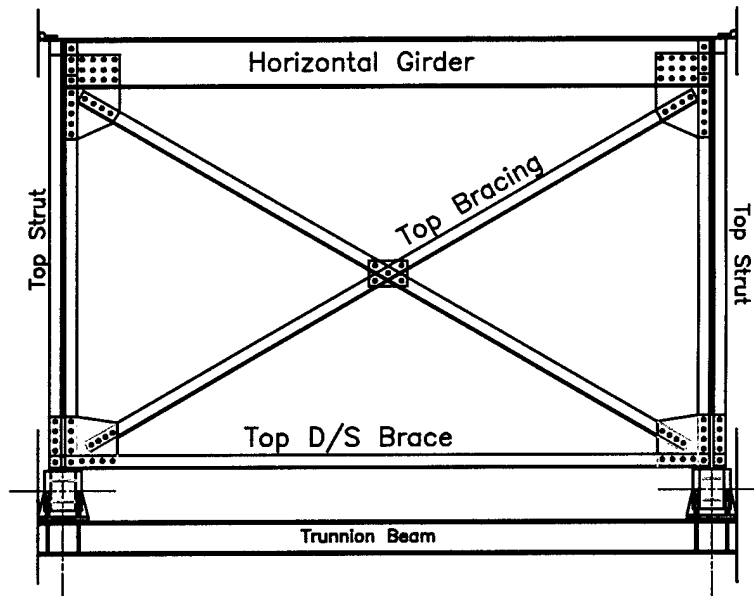

Figure 6 - 8 ft by 6 ft sluice gate top plan.

Member Section Dimensions

Section dimensions of main structural members were measured to verify conformance with the design drawings. These members included radial struts, top and bottom bracing, the side plate and the horizontal girders. Measured dimensions were recorded on inspection sheets found in Appendix B. The data sheets also contain nominal section dimensions from the American Institute of Steel Construction (AISC) *Manual of Steel Construction, Seventh Edition, 1970*. Section measurements typically include the depth, d (measured at the edges of the flanges), the flange width, b_f and the flange thickness, t_f . Web thickness, t_w , was only measured if there was an exposed portion of the web or drain holes large enough for calipers.

Differences between the design drawings and the actual field conditions of $1/16^{\text{th}}$ inch or less were deemed to be insignificant. All members in the field were found to be greater or equal in dimension than what was required in the design drawings. The larger dimensions were probably due to inaccuracies on the field measurements resulting from difficult access or with the thickness of the paint on the members

Radial Struts and Braces

The radial struts are constructed of two 4 inch by 4 inch by $3/8$ inch angles welded back to back. All braces are 3 inch by 3 inch by $3/8$ inch angles. The struts and braces have solid rivet connections to all members. Struts and braces are in good condition with patches of light rust.

Horizontal Girders

The seven horizontal girders are C8x11.5 channels. The channels are in good condition with patches of light rust. The girders are welded to the gate face and connected to side plates by an angle that is riveted to the girder and the side plate. The bottom girder has evidence of standing water with light to moderate rust.

Rivets and Connections

Riveted connections are in good condition with isolated spots of light corrosion. The gusset plate connecting the top left strut and top bracing to the top girder is deformed approximately $1/4$ -inch. See photo 25. It is unclear if this was caused by stress in the plate or something being dropped from above. The bolt holes at the connection of the top girder and the top seal have been flame cut to a slotted hole. This is typical across the top seal. See photo 26.

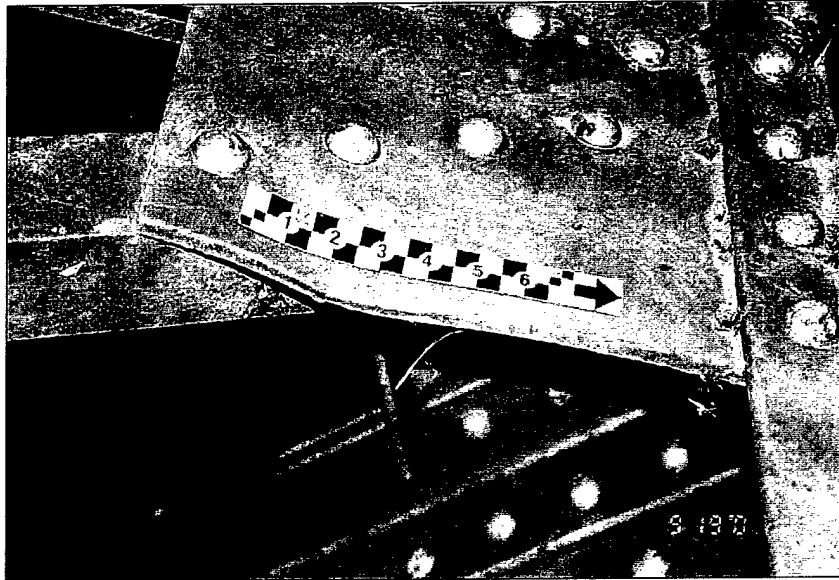

Photo 25 – Gusset plate at top strut connection to top girder.

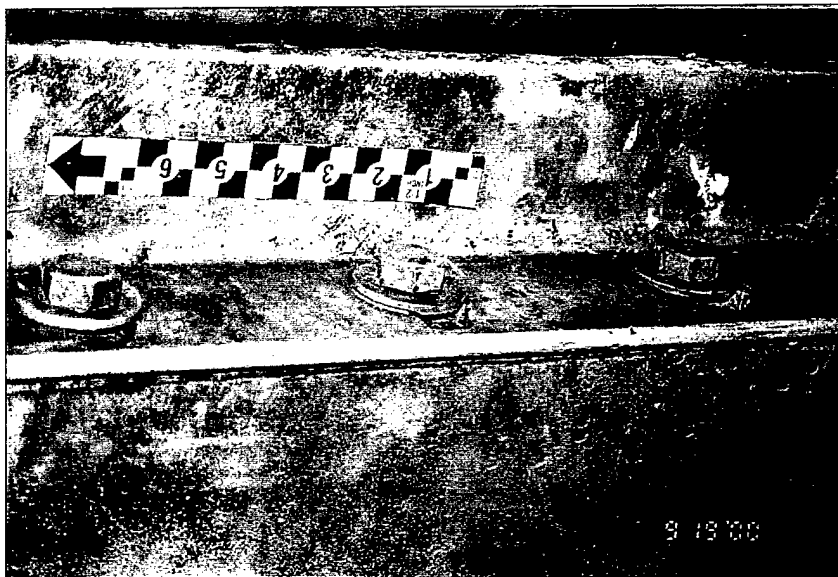

Photo 26 – Top girder connection to top seal, flame cut slotted bolt holes.

Trunnion

The trunnion consists of a 3-1/2 inch pin contained by a 1-1/2 inch thick bushing. All components of the trunnion are in good condition with only light surface corrosion at isolated locations. See photo 27.

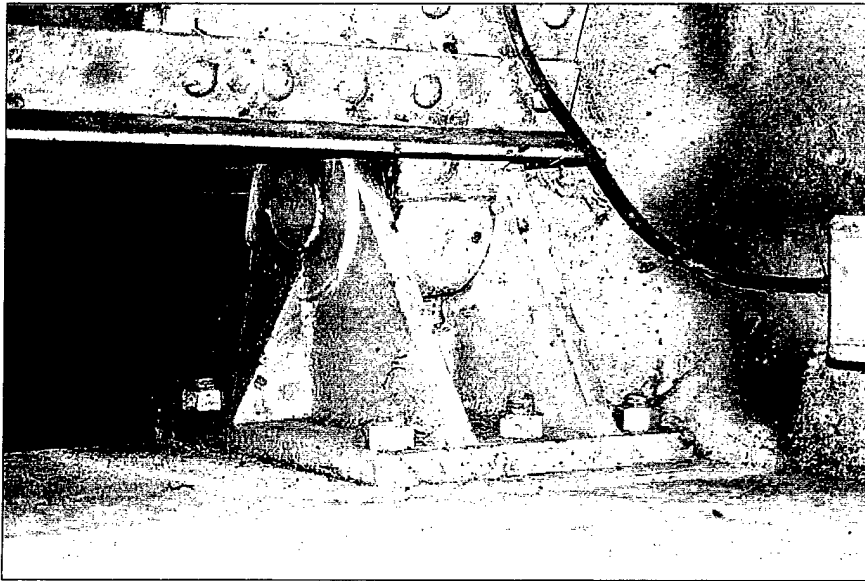

Photo 27 – Left trunnion connection.

Skin Plate

The upstream portion of the skin plate was not accessible for inspection. The downstream skin plate is in good condition with light rust from drainage around drain holes.

Side, Top and Bottom Seals

The side seals were not accessible due to the design of the gate and the location of the side plates. The bottom seals were also not accessible due to the necessity for the gate to remain open during the inspection and the depth of and running water beneath it. The top seals are in generally good condition.

Electric side seal heaters have been installed on the gate at some time in the past. There is no indication of the heaters on the provided as-built plans. No determination as to the working condition of the heaters was made. See photo 28.

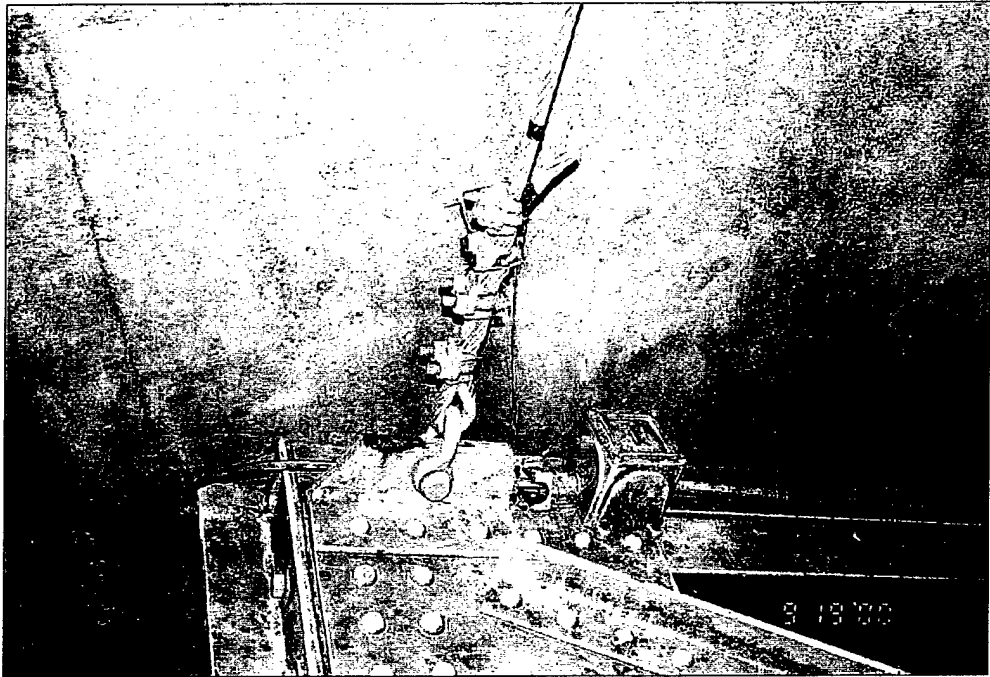

Photo 28 – Seal heater installed on gate.

RECOMMENDATIONS

6 ft. x 14 ft. (Armco) Radial Gate:

- The gate should be waterblasted clean and repainted within 5 years. The downstream plate should be removed in order to paint the enclosed horizontal girders and the skin plate.

8' x 18' Radial Gates:

Recommended at next dewatering

- Gates 1 and 4 should be re-centered so as not to be dragging on the pier walls.

Recommended in next 5 years

- Drainage holes should be provided for the horizontal girders which are rotated to cause ponding against the skin plate. The drain holes should be 1-inch in diameter and spaced at approximately 24-inches along the girders. The edge of hole should be located approximately 1/2-inch from the girder flange. The holes should be drilled, not flame cut (the use of a mag-drill is recommended). If flame cut holes are the only available option, the edges of the holes should be reamed smooth.
- At the bottom horizontal girder, the existing holes through the web (without bolts to the bumper) should be continued through the bumper to provide drainage. Note: A 24-inch spacing of the drain holes would only require that every other non-bolted hole was continued through the bumper.
- Drainage holes should be provided in the web of the trunnion at the upstream side (low side). The drain holes should be 1-inch in diameter and spaced at approximately 24-inches along the beam. The holes should be drilled, not flame cut. If flame cut holes is the only available option, the edges of the holes should be reamed smooth.
- The exposed metal edges of the new drain holes should be spot painted.
- Spot waterblast cleaning and painting should be performed at locations of light to moderate corrosion.
- The upstream side of the skin plate should be waterblast cleaned and repainted. A moisture cured urethane is recommended.

8 ft by 6 ft Sluice Gate (North Radial Gate):

- The gate is in generally good condition but should continue to be monitored for changes in condition. It is recommended that the gate be re-inspected in 10 years.

REFERENCES

1. Water Control Manual, Mill Creek Lake, U.S. Army Engineer District, Walla Walla, July 1991.

Gate No. 1 ONLY Left Elevation B-B

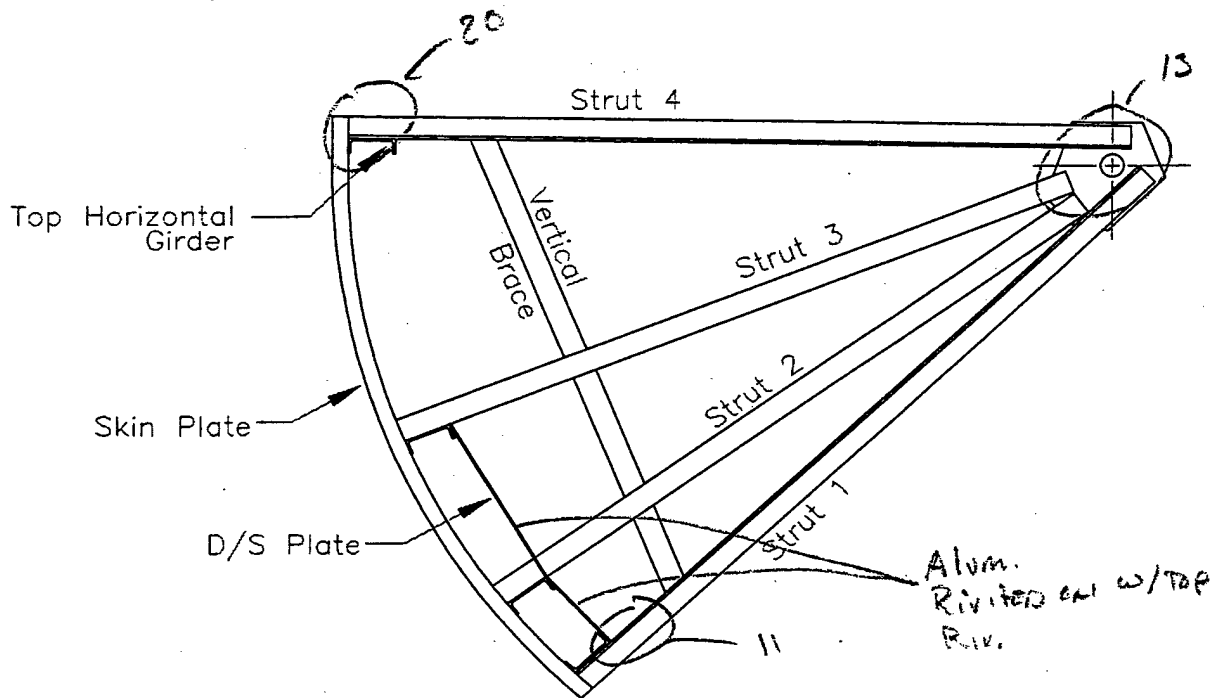

Member	Type	Depth		Web		Flange			
		d		t _w		b _f		t _f	
		Plan (in)	Measured (in)	Plan (in)	Measured (in)	Plan (in)	Measured (in)	Plan (in)	Measured (in)
Strut 4	X		2 1/2		1/4		2 1/2		
Strut 3	X		2 1/2		1/4		2 1/2		
Strut 2	X		2 1/2		1/4		2 1/2		
Strut 1	X		2 1/2		1/4		2 1/2		
Vertical Brace	BAR		2		1/2				

1. OVER VIEW 2. LEFT SIDE SEAL 3. RT SIDE SEAL

11. Bottom Gus. Plt. light Cor.

13. Lt termination NOTE GREASE OPENING, NO WELD

GENERAL NOTES

16. Torq tube 17. Machinery 18. LEFT ELEVATION

20. Connection bolts 1/2" TYP.

Gate No. ARM Right Elevation A-A

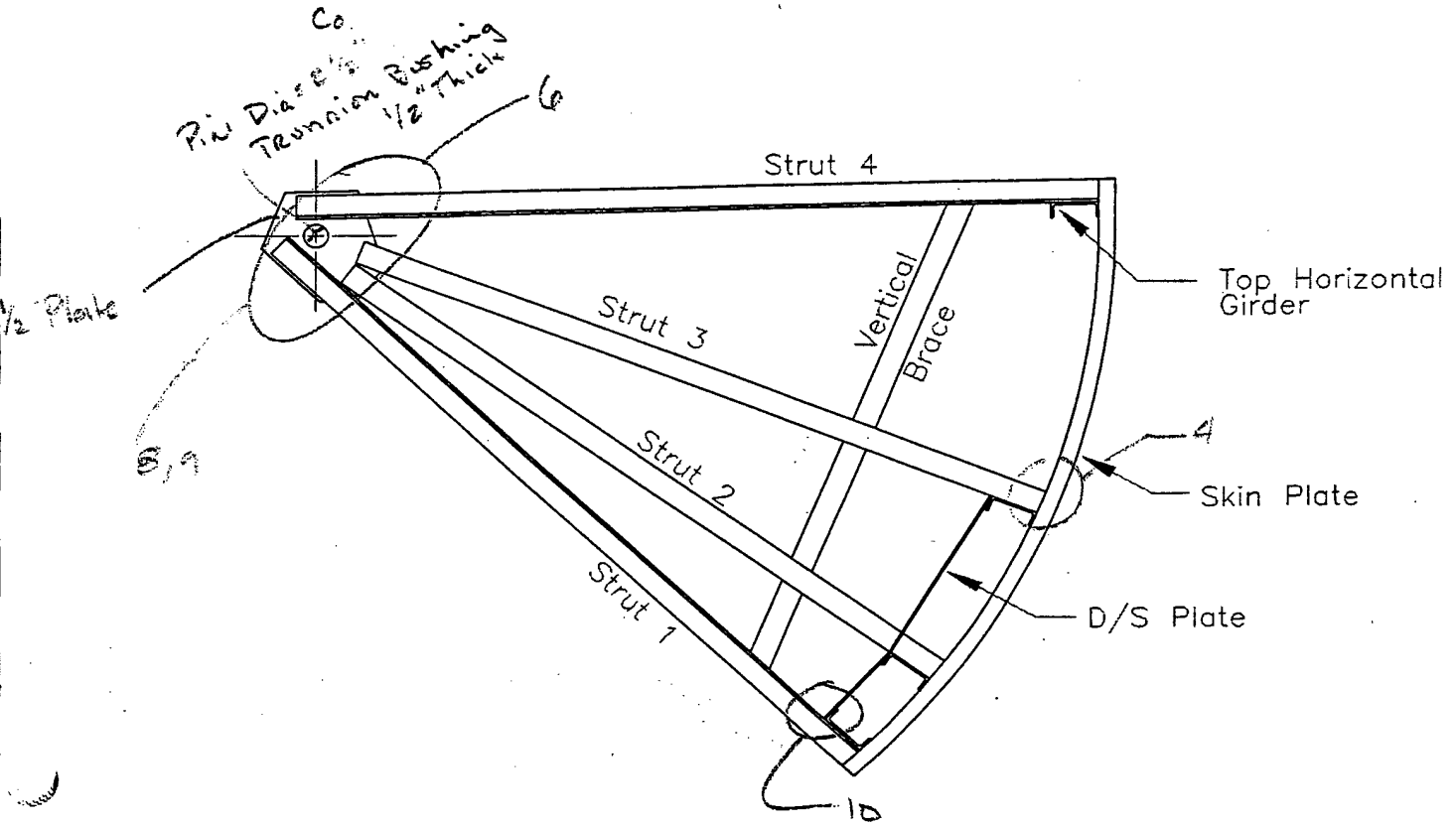

Member	Type	Depth d		Web t _w		Flange			
		Plan (in)	Measured (in)	Plan (in)	Measured (in)	b _f		t _f	
						Plan (in)	Measured (in)	Plan (in)	Measured (in)
Strut 4	∠		2 1/2		1/4		2 1/2		
Strut 3	∠		2 1/2		1/4		2 1/2		
Strut 2	∠		2 1/2		1/4		2 1/2		
Strut 1	∠		2 1/2		1/4		2 1/2		
Vertical Brace	Bar		2		1/2				

- 4. Connection of Strut 3 to gate.
- 6. RT Transition
- 8. Transition 9. Transition light surface corrosion
- 10. light Corros. @ Bolts & connection
- 15. Bob RADKE (man w/the keys) COE

Gate No. Armed Top Bracing

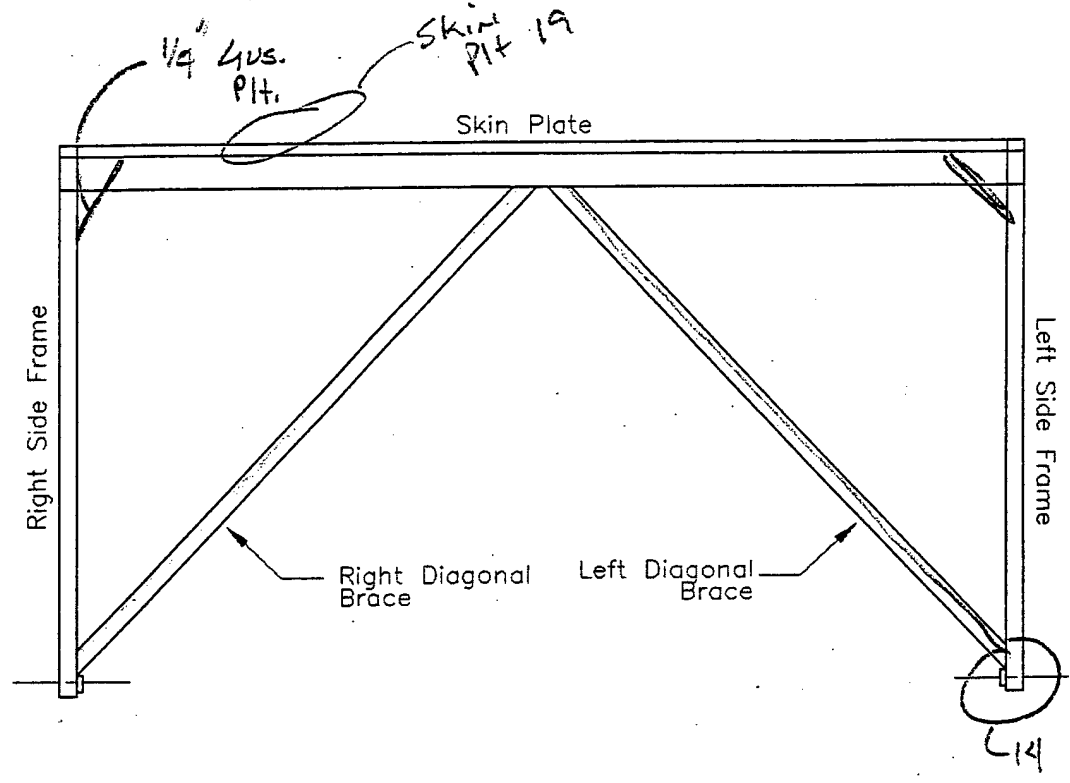

Member	Type	Depth		Web		Flange			
		d		t _w		b _f		t _f	
		Plan (in)	Measured (in)	Plan (in)	Measured (in)	Plan (in)	Measured (in)	Plan (in)	Measured (in)
R. Diagonal Br	←		2 1/2		1/2		2 1/2		
L. Diagonal Br.	←		2 1/2		1/2		2 1/2		

- 13. LT. TRANSDUCER, LIGHT PRESSURE @ Bushing Frame pier
- 14. Same as 13
- 19. Skin Plt Sidespl

Gate No. Amco Downstream Elevation

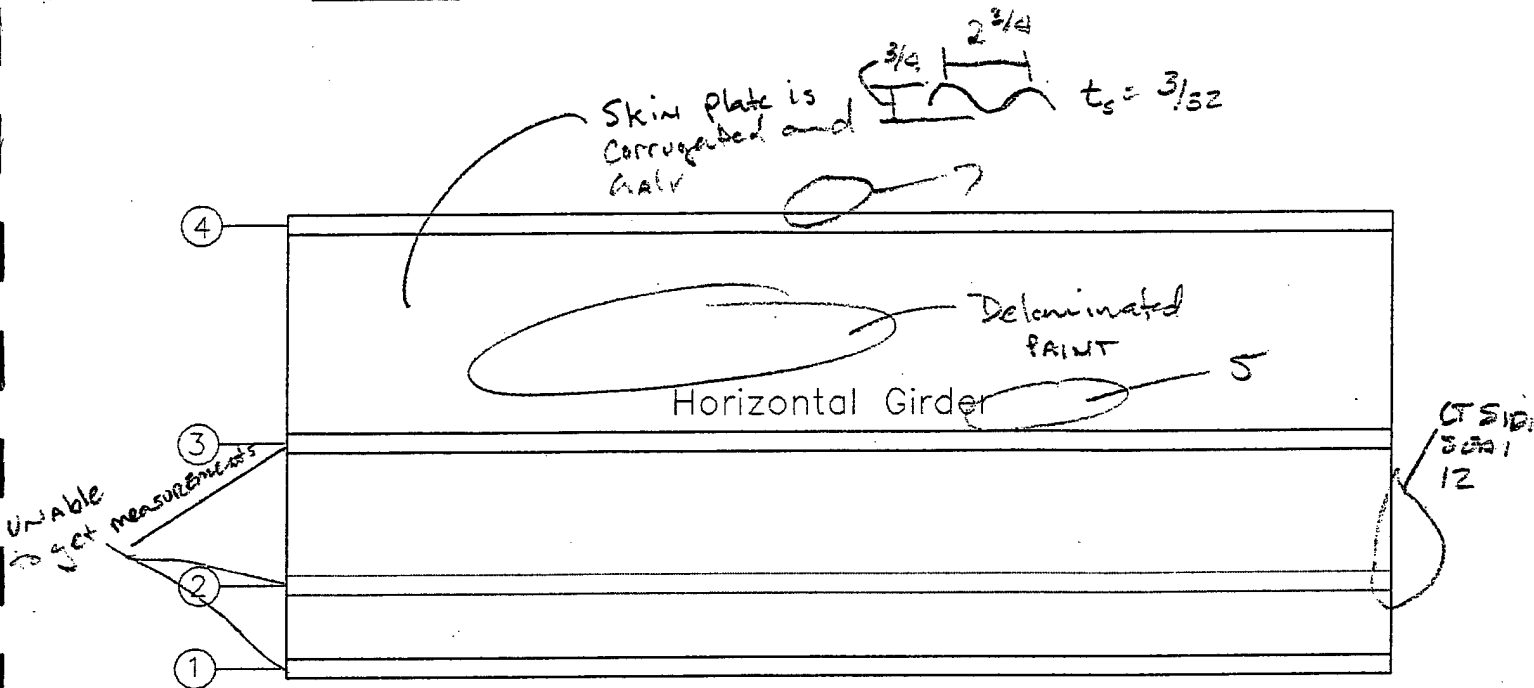

Member	Type	Depth d		Web t _w		Flange			
		Plan (in)	Measured (in)	Plan (in)	Measured (in)	b _f		t _f	
						Plan (in)	Measured (in)	Plan (in)	Measured (in)
Downstream PL									
Horiz. Girder 4	Channel		9		1/4		2		3/8
Horiz. Girder 3									
Horiz. Girder 2									
Horiz. Girder 1									

- 5. Delaminated paint on skin plate
- 7. Skin plate Top view
- 12. Light cracking in CT SIDE SEAL

Gate No. 1 Left Elevation B-B

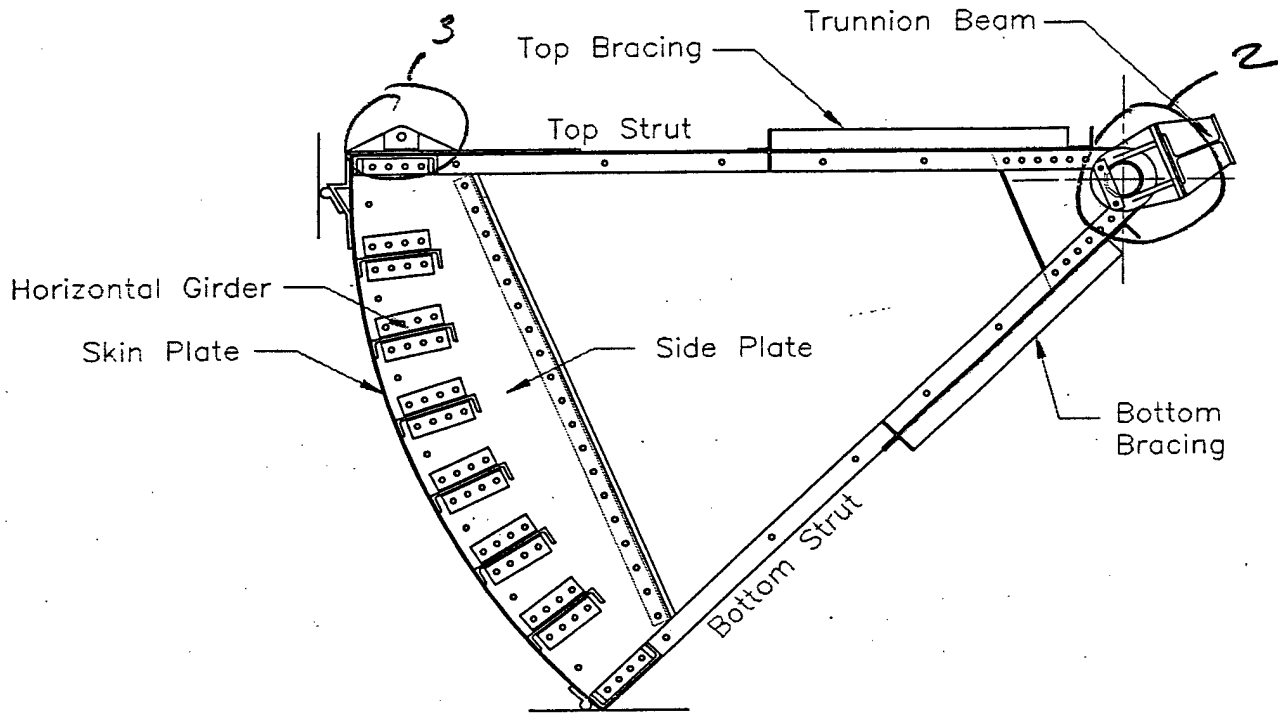

Member	Type	Depth		Web		Flange			
		d		t _w		b _f		t _f	
		Plan (in)	Measured (in)	Plan (in)	Measured (in)	Plan (in)	Measured (in)	Plan (in)	Measured (in)
Top Strut	2-L 4x4x3/8	4	4	3/8	3/8	4	4	3/8	—
Bottom Strut	2-L 4x4x3/8	4	4	3/8	3/8	4	4	3/8	—

1. GATE # 2. LFT Trunnion (good condition, some chipped paint)
 3. LFT. Polly system, Light Rust Heavy Greasings

11. OVERALL Pict.
 12. SAM ON GATE 3

Gate No. 1 Right Elevation A-A

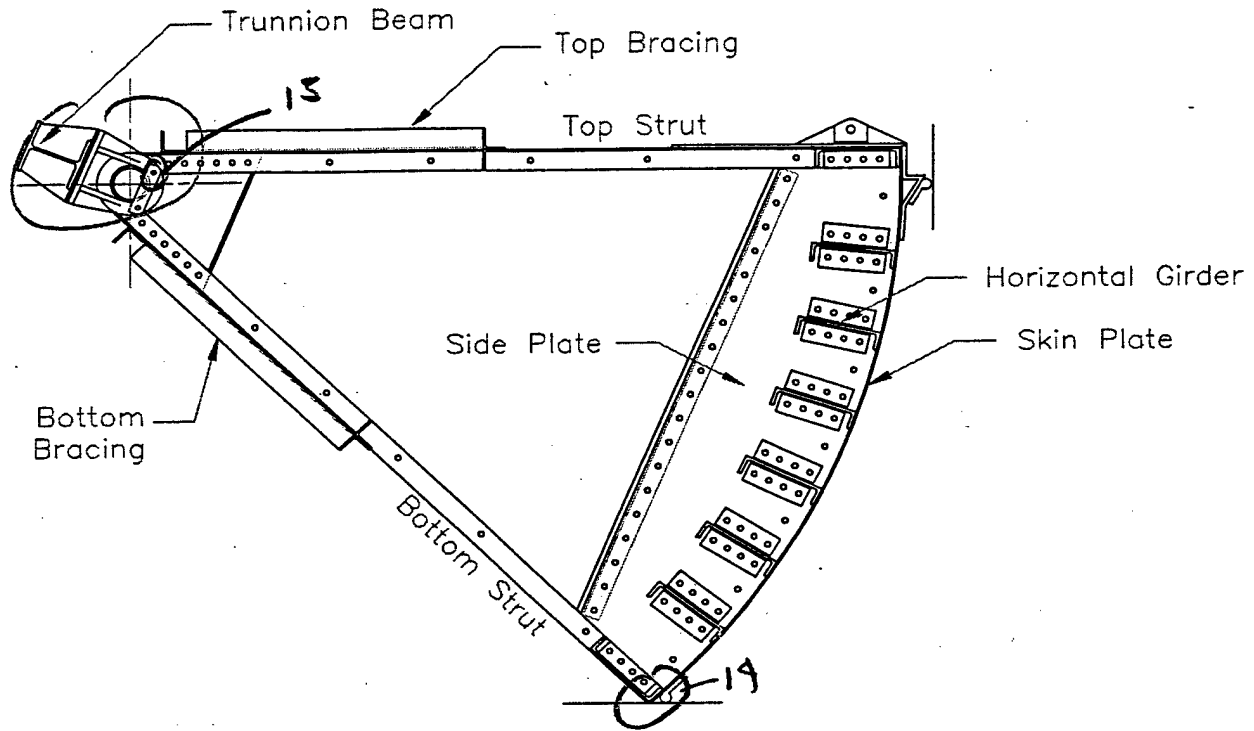

Member	Type	Depth		Web		Flange			
		d		t _w		b _r		t _r	
		Plan (in)	Measured (in)	Plan (in)	Measured (in)	Plan (in)	Measured (in)	Plan (in)	Measured (in)
Top Strut	2-L 4x4x3/8	4		3/8		4		3/8	—
Bottom Strut	2-L 4x4x3/8	4	4	3/8	3/8	4	4	3/8	—

4 RT Trunnion Light Rust and delaminated paint
 4 (cont) NOTE Delam. Paint on trunnion beam
 13. NEW Bolts @ Trunnion Looks like a locking plate
 14. Bot. STRUT Bent @ Seal NOTE Light Rust

Gate No. 1 Top Bracing

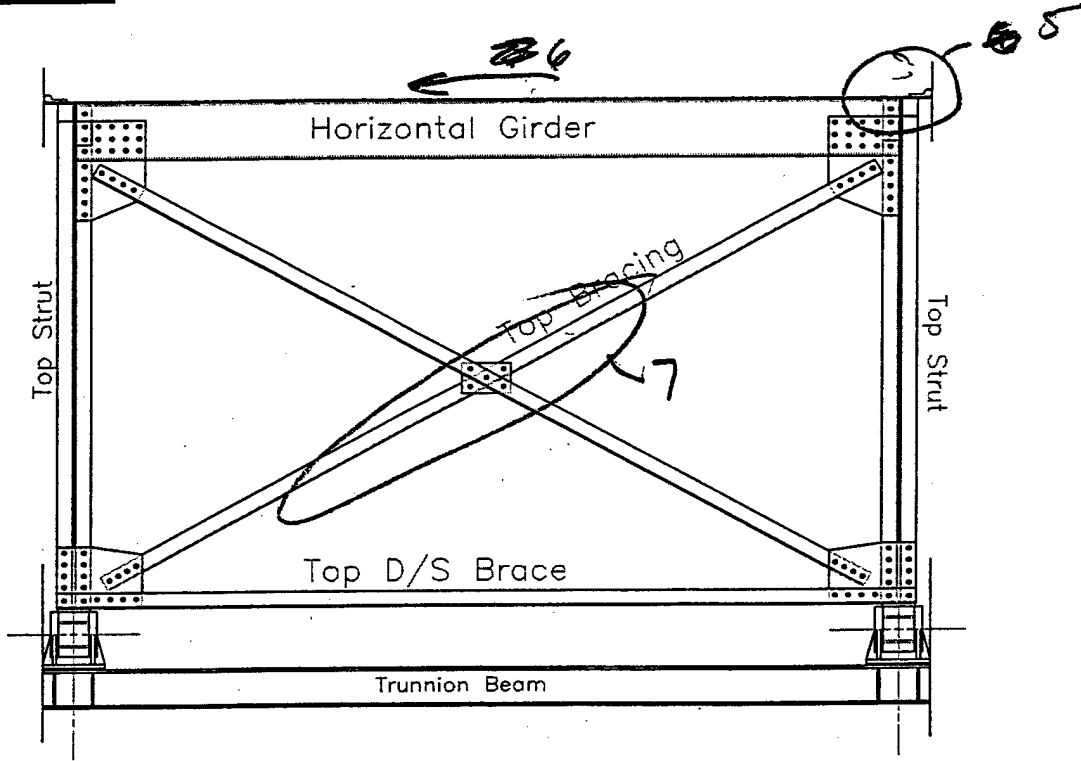

Member	Type	Depth		Web		Flange			
		d		t _w		b _f		t _f	
		Plan (in)	Measured (in)	Plan (in)	Measured (in)	Plan (in)	Measured (in)	Plan (in)	Measured (in)
Top Bracing	2-L 4x4x3/8	4	4	3/8	7/16	4	4		
Top D/S Brace	2-L 4x4x3/8	4	4	3/8	7/16	4	4		
Trunnion Beam	10 WF 60	10 1/4	10 3/16	7/16		10 1/8	10	11/16	

- 5: Heaving Mech. @ LFT FRM
- 6: Looking RT. @ Top Seal
- 7: Light Rust w/ chipped PNT.

Gate No. 1 Downstream Elevation

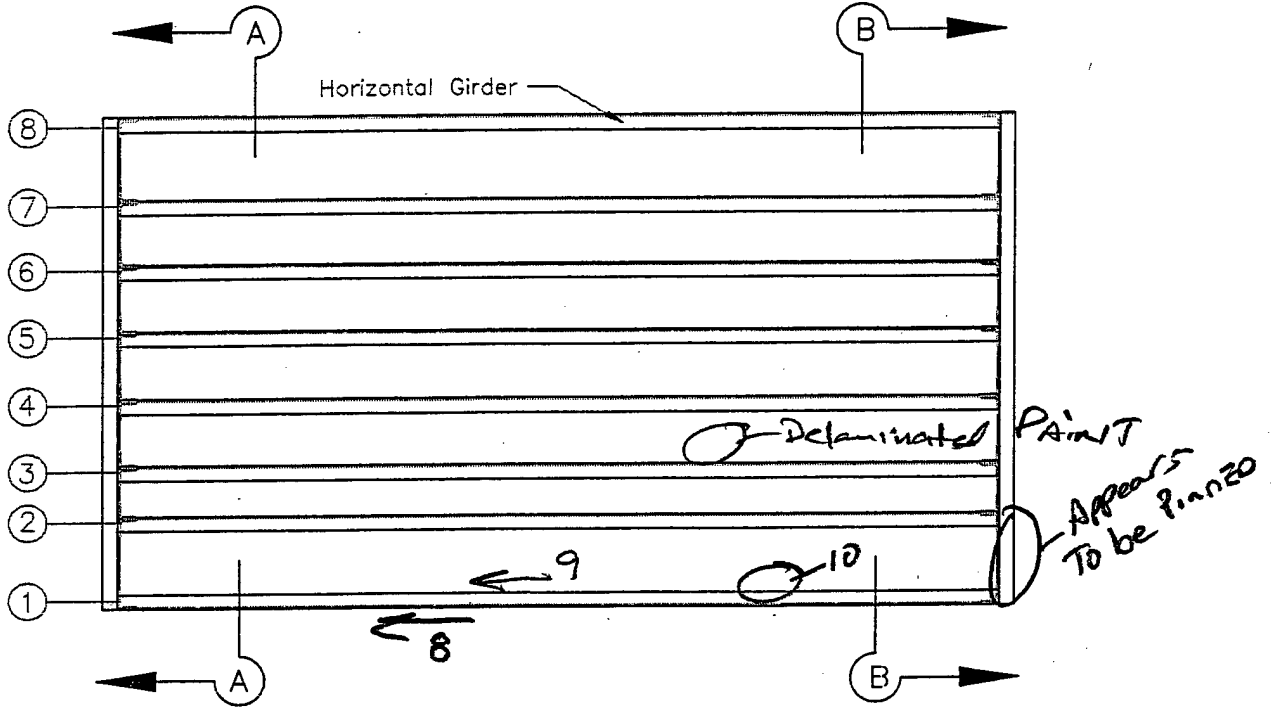

Member	Type	Depth d		Web t _w		Flange			
		Plan (in)	Measured (in)	Plan (in)	Measured (in)	Plan (in)	Measured (in)	Plan (in)	Measured (in)
Horiz. Girder 8	C 15 x 40	15	15	9/16	9/16	3 1/2	3 3/8	5/8	
Horiz. Girder 7	C 15 x 40	15	15	9/16		3 1/2		5/8	
Horiz. Girder 6	C 15 x 40	15	15	9/16		3 1/2		5/8	
Horiz. Girder 5	C 15 x 40	15	15	9/16		3 1/2		5/8	
Horiz. Girder 4	C 15 x 40	15	15	9/16		3 1/2		5/8	
Horiz. Girder 3	C 15 x 40	15	15	9/16		3 1/2		5/8	
Horiz. Girder 2	C 15 x 40	15	15	9/16		3 1/2		5/8	
Horiz. Girder 1	C 15 x 40	15	15	9/16		3 1/2		5/8	

- 8. Bot. Seal NEW BOARD ON RT. SIDE ONLY
- 9. Bot GIBER looking RT. END. OF STANDING WATER W/ Debris
- 10. Bolts to bot seal EVERY other bolt missing

Gate No. _____ Upstream Elevation _____

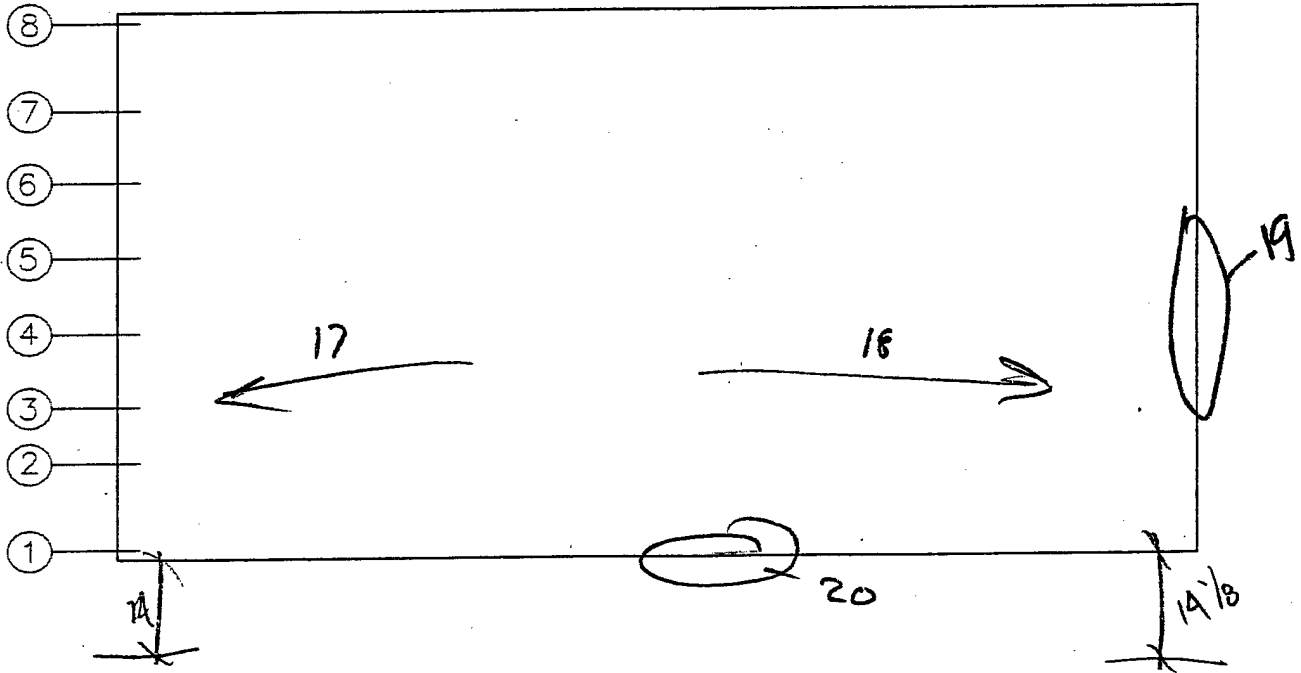

- 17. GATE FACE looking LFT
- 18. " " " RT
- 19 RT Side SEAL
- 20 Bottom SEAL

- HEAVY VIBRATION WHILE OPENING, STARTING 1'
- STOPPED AT 14" OPEN

- BOTTOM BRIDGES VIBRATING, LOOKS LIKE
BINDING ON RIGHT (US)

Gate No. 2 Left Elevation B-B

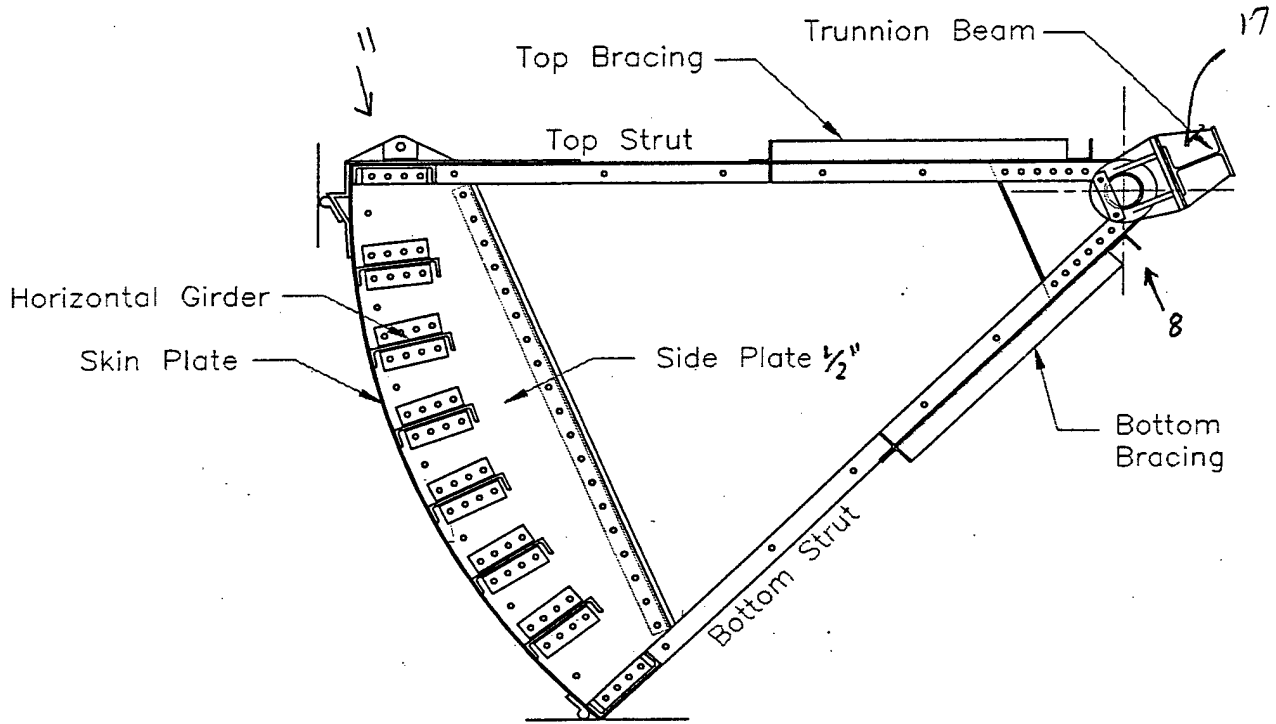

Member	Type	Depth		Web		Flange			
		d		t _w		b _r		t _r	
		Plan (in)	Measured (in)	Plan (in)	Measured (in)	Plan (in)	Measured (in)	Plan (in)	Measured (in)
Top Strut	2-L 4x4x3/8	4	4	3/8	3/8	4	4	3/8	—
Bottom Strut	2-L 4x4x3/8	4	4	3/8	3/8	4	4	3/8	—

17) PLAM ON TRUN BEAM TYP

Gate No. 2 Bottom Bracing

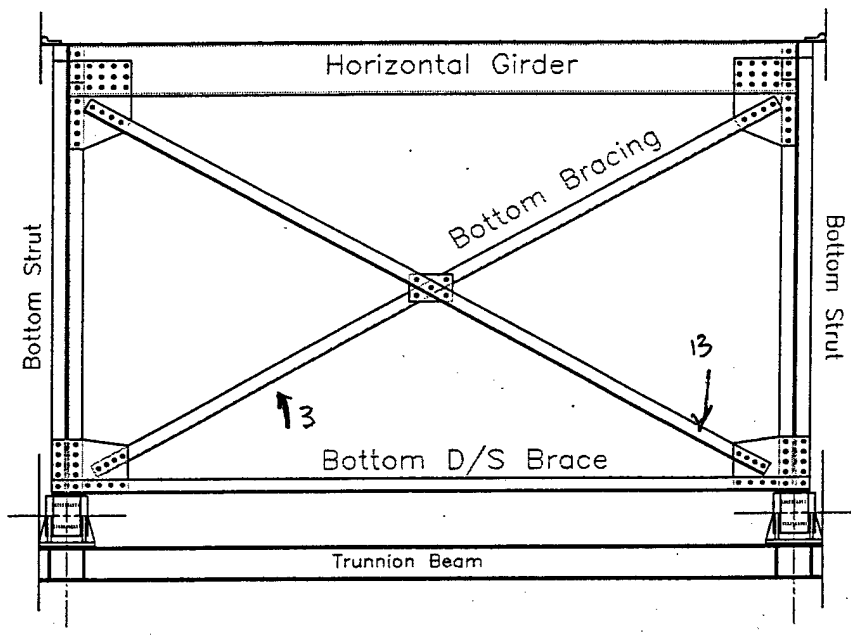

Member	Type	Depth		Web		Flange			
		d		t _w		b _f		t _f	
		Plan (in)	Measured (in)	Plan (in)	Measured (in)	Plan (in)	Measured (in)	Plan (in)	Measured (in)
Bot. Bracing	2-L 4x4x3/8	4	4	3/8	3/8	4	4		—
Bot. D/S Brace	2-L 4x4x3/8	4	4	3/8	3/8	4	4		—

3) DELTA & LIGHT COR TYP BOTTOM BRACING

13) DEFORMATION IN ANGLE

Gate No. 2 Downstream Elevation

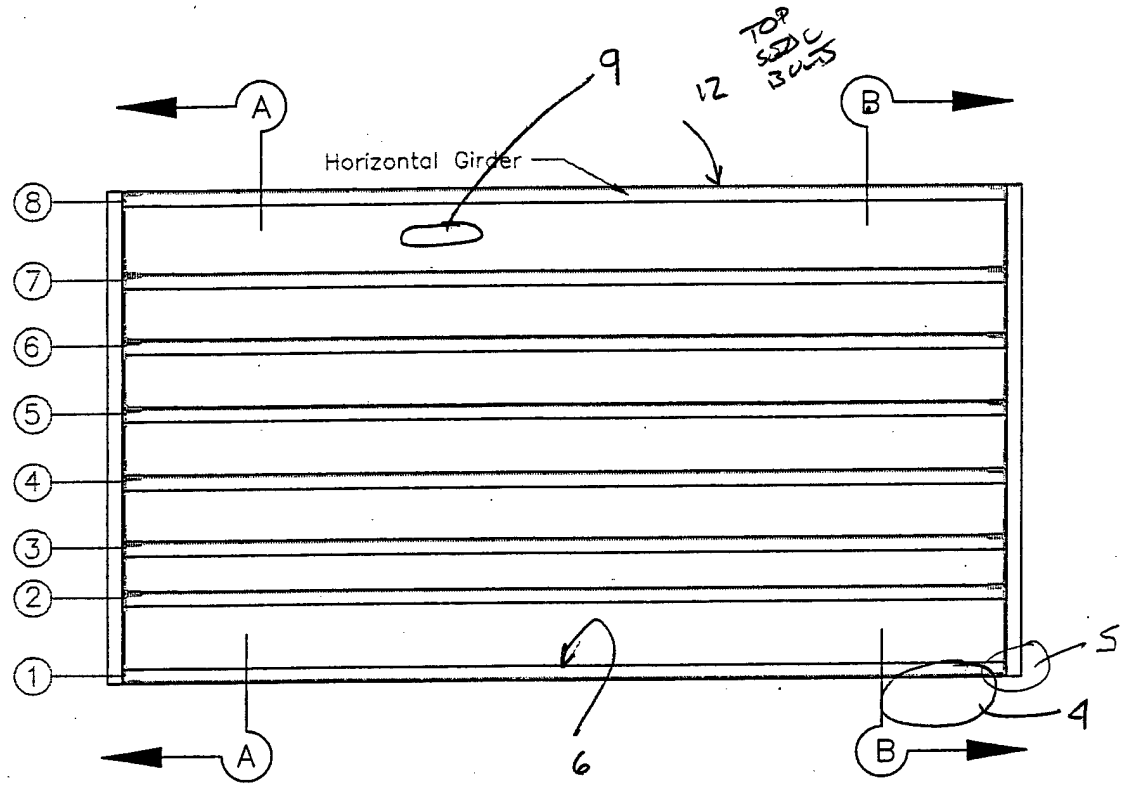

Member	Type	Depth d		Web t _w		Flange			
		Plan (in)	Measured (in)	Plan (in)	Measured (in)	b _f		t _f	
						Plan (in)	Measured (in)	Plan (in)	Measured (in)
Horiz. Girder 8	C 15 x 40	15	15	9/16		3 1/2	3 3/8	5/8	5/8
Horiz. Girder 7	C 15 x 40	15	15	9/16		3 1/2		5/8	
Horiz. Girder 6	C 15 x 40	15	15	9/16		3 1/2		5/8	
Horiz. Girder 5	C 15 x 40	15	15	9/16		3 1/2		5/8	
Horiz. Girder 4	C 15 x 40	15	15	9/16		3 1/2		5/8	
Horiz. Girder 3	C 15 x 40	15	15	9/16		3 1/2		5/8	
Horiz. Girder 2	C 15 x 40	15	15	9/16		3 1/2		5/8	
Horiz. Girder 1	C 15 x 40	15	15	9/16		3 1/2		5/8	

- 4) BOTTOM SEAL (TYP)
- 5) DEFORMATION @ BOTTOM ANGLE
- 5) DEBRIS, ~~SEAL~~ CLOGGED WATER
- 9) LOWER CONNECTION TOP SEAL (TYP)

1 = EAST

HDR Engineering, Inc.
 Corp of Engineers - Walla Walla
 Mill Creek Dam - 8' x 18' Gates

Inspection Team SMP TDB
 Weather Sunny 75°

Date 9/19
 Sheet 1

Gate No. 3 Left Elevation B-B

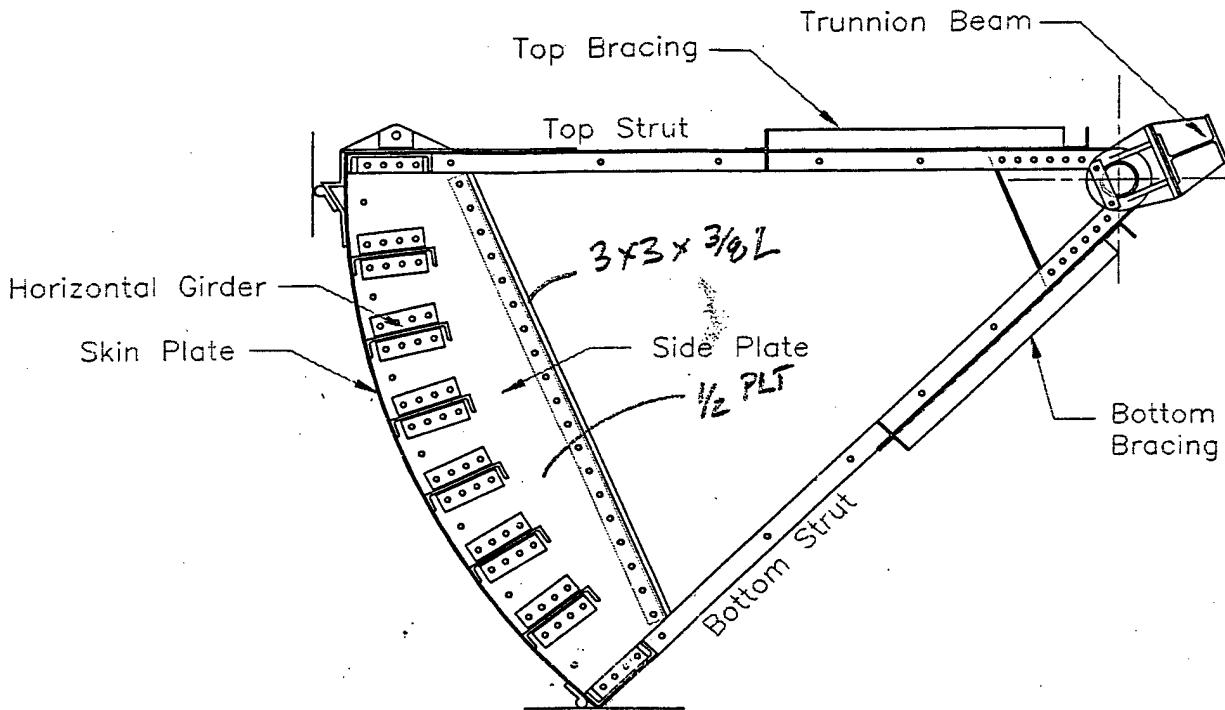

Member	Type	Depth		Web		Flange			
		d		t _w		b _f		t _f	
		Plan (in)	Measured (in)	Plan (in)	Measured (in)	Plan (in)	Measured (in)	Plan (in)	Measured (in)
Top Strut	2-L 4x4x3/8	4	4	3/8	5/8	4	4	3/8	---
Bottom Strut	2-L 4x4x3/8	4	4	3/8	3/8	4	4	3/8	---

1, 2 misc. shots

3. overview

* GATE WAS RAISED 22 5/8"

Gate No. 3 Top Bracing

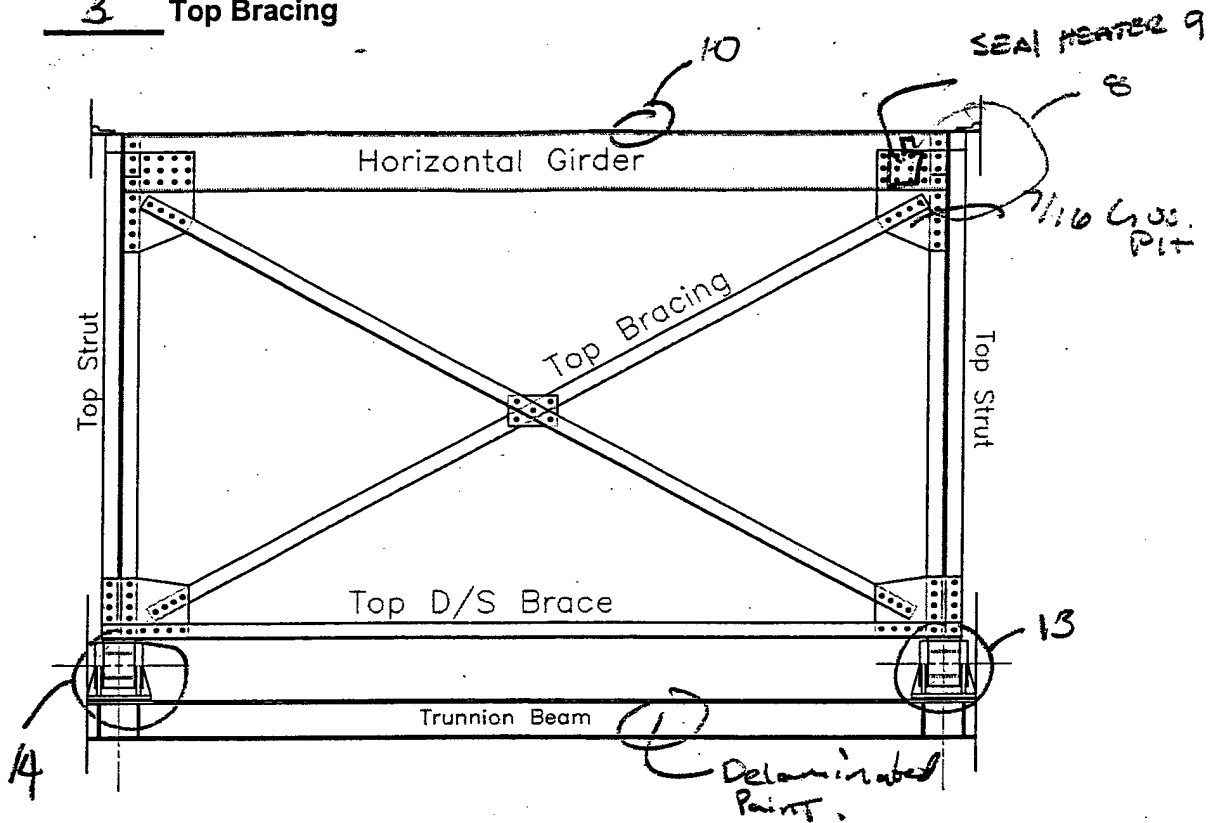

Member	Type	Depth d		Web t _w		Flange			
		Plan (in)	Measured (in)	Plan (in)	Measured (in)	Plan (in)	Measured (in)	Plan (in)	Measured (in)
Top Bracing	2-L 4x4x3/8	4	4	3/8	3/8	4	2 1/2		
Top D/S Brace	2-L 4x4x3/8	4	4	3/8	3/8	4	4		
Trunnion Beam	10 WF 60	10 1/4	10	7/16	7/16	10 1/8	10 3/16	11/16	

8. LFT Pully syst. NOTE Delam. Dot and light Rust

9. SEAL HTR. Plastic Connector Disl. (QUESTION IF IT IS REALLY A SEAL HEATER)

10. Loose Bolt ON TOP SEAL. I CAN TURN IT BY 3/4"

13. LFT TRUNNION 14. RT TRUNNION

Gate No. 3 Downstream Elevation

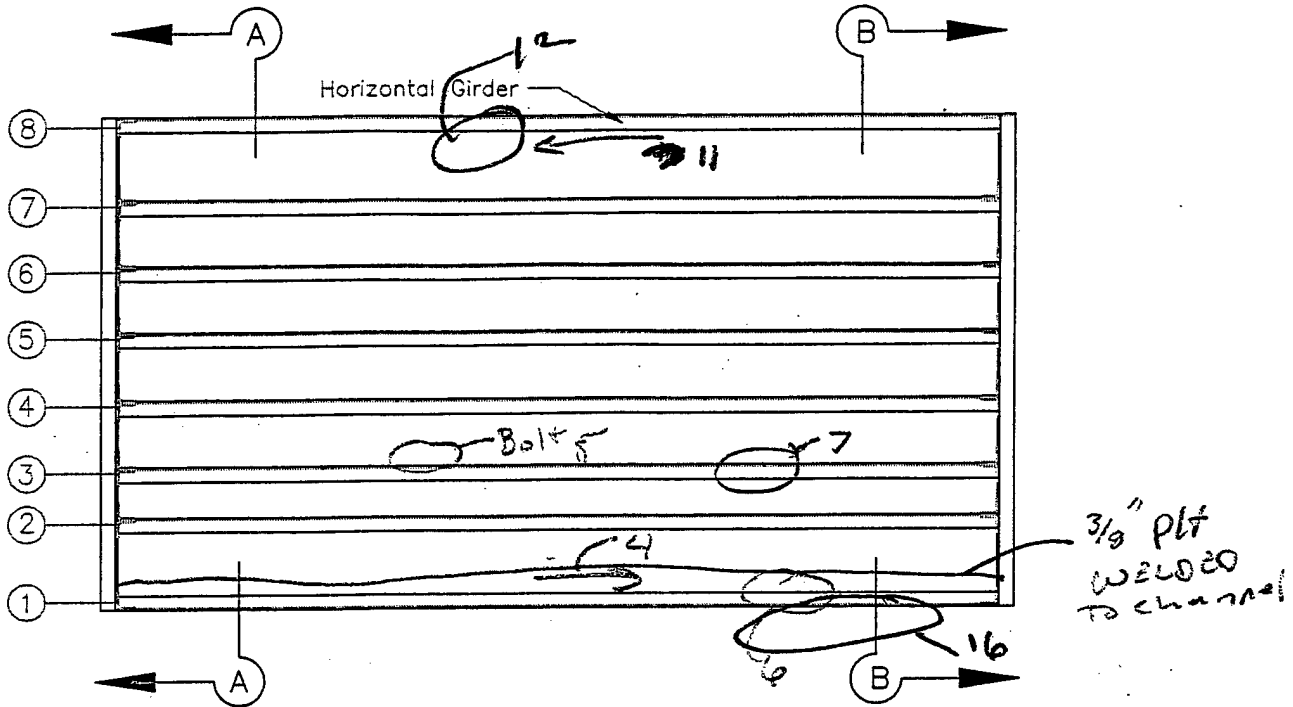

Member	Type	Depth d		Web t _w		Flange			
		Plan (in)	Measured (in)	Plan (in)	Measured (in)	b _f		t _f	
						Plan (in)	Measured (in)	Plan (in)	Measured (in)
Horiz. Girder 8	C 15 x 40	15	15	9/16	9/16	3 1/2	3 1/8	5/8	
Horiz. Girder 7	C 15 x 40	15	15	9/16		3 1/2	3 1/8	5/8	
Horiz. Girder 6	C 15 x 40	15	15	9/16		3 1/2	3 1/8	5/8	
Horiz. Girder 5	C 15 x 40	15	15	9/16		3 1/2	3 3/8	5/8	
Horiz. Girder 4	C 15 x 40	15	15	9/16		3 1/2	3 3/8	5/8	
Horiz. Girder 3	C 15 x 40	15	15	9/16		3 1/2	3 3/8	5/8	
Horiz. Girder 2	C 15 x 40	15	15	9/16		3 1/2	3 3/8	5/8	
Horiz. Girder 1	C 15 x 40	15	15	9/16	✓	3 1/2	3 3/8	5/8	

- 8. Bottom chnl looking LFT. Evidence of stones water
- 5. Misc. Bolt on girder #8 more delaminated PAINT on skin pl.
- 6. EVERY other bolt hole is missing a Bolt to bottom seal
- 7. Small Dimp on girder #3
- 11. Missing bolts @ top girder 2 missing
- 12. Bolt @ top seal looks like they were TACKED WELDED. Some have no weld.
- 10. Bottom seal NEW ROAD on LFT SIDE

Gate No. 3 Upstream Elevation

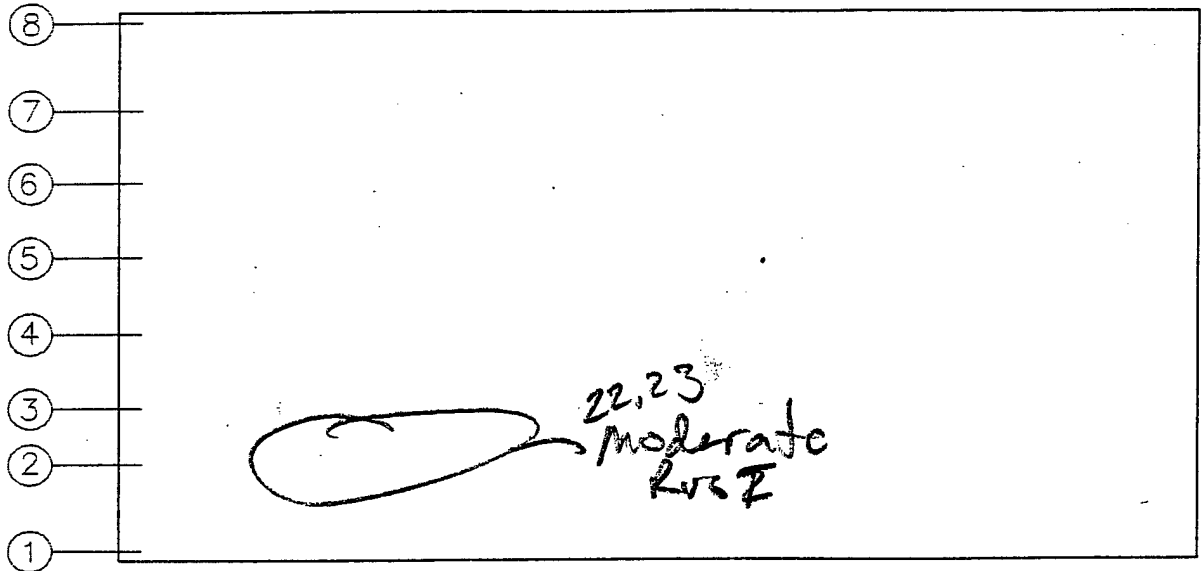

NEW Role

21 Gate #2

NOTE - NO TRASH RACK
-SEALS LOOK GOOD
Call

Gate No. 4 Left Elevation B-B EAST

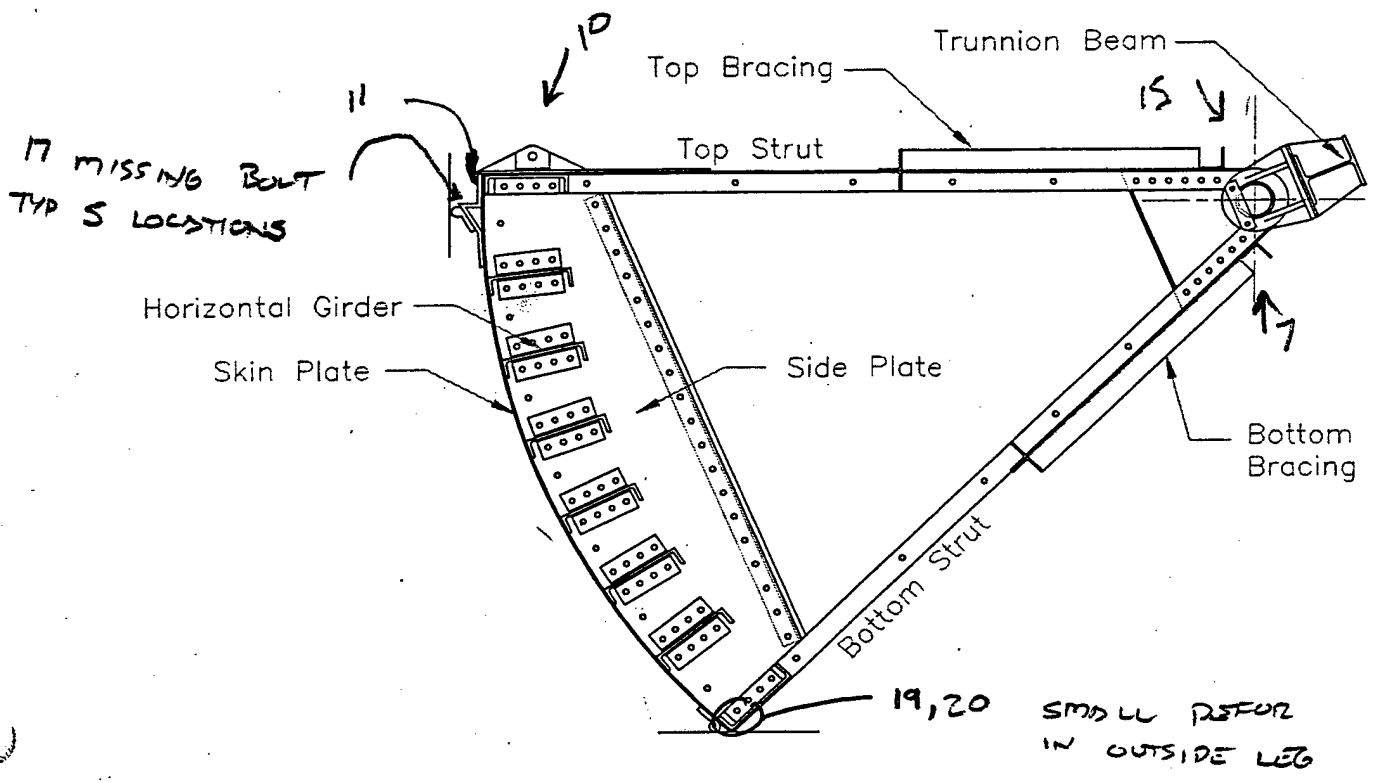

Member	Type	Depth		Web		Flange			
		d		t _w		b _f		t _f	
		Plan (in)	Measured (in)	Plan (in)	Measured (in)	Plan (in)	Measured (in)	Plan (in)	Measured (in)
Top Strut	2-L 4x4x3/8	4	4	3/8	3/8	4	4	3/8	—
Bottom Strut	2-L 4x4x3/8	4	4	3/8	3/8	4	4	3/8	—

2) OVERVIEW

11) TOP SEAL ANGLE (TYP)

Gate No. 4 Top Bracing

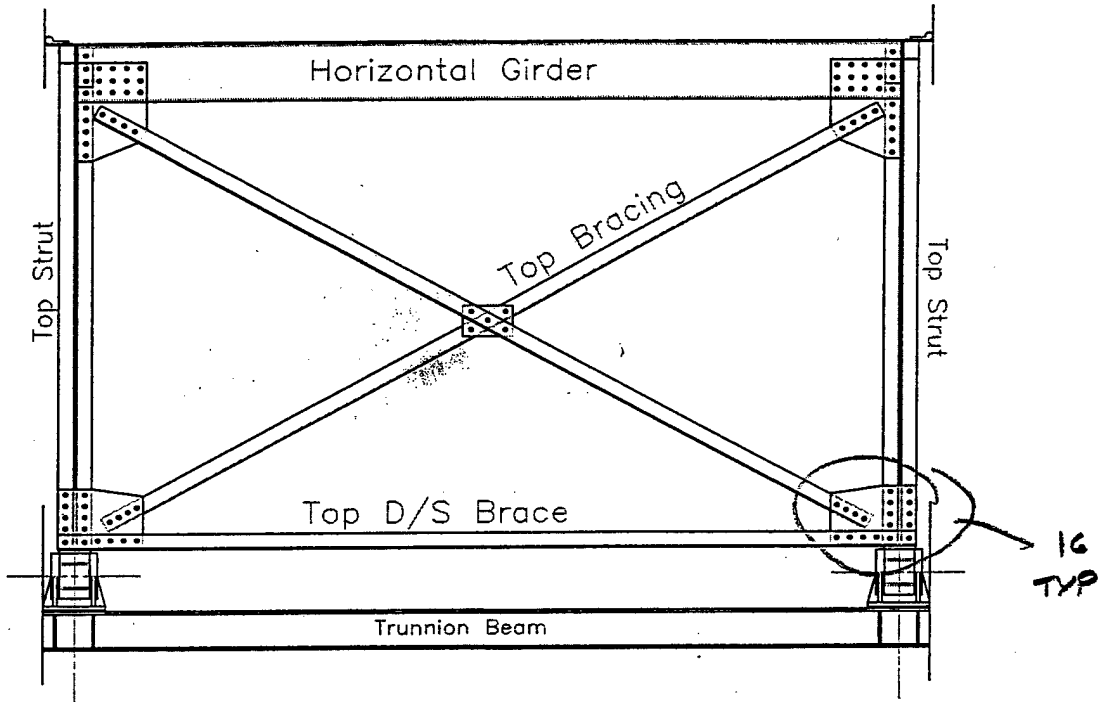

Member	Type	Depth		Web		Flange			
		d		t _w		b _f		t _f	
		Plan (in)	Measured (in)	Plan (in)	Measured (in)	Plan (in)	Measured (in)	Plan (in)	Measured (in)
Top Bracing	2-L 4x4x3/8	4	4	3/8	3/8	4	4		—
Top D/S Brace	2-L 4x4x3/8	4	4	3/8	3/8	4	4		—
Trunnion Beam	10 WF 60	10 1/4	10 1/4	7/16		10 1/8	10 3/16	11/16	11/16

Gate No. 4 Downstream Elevation

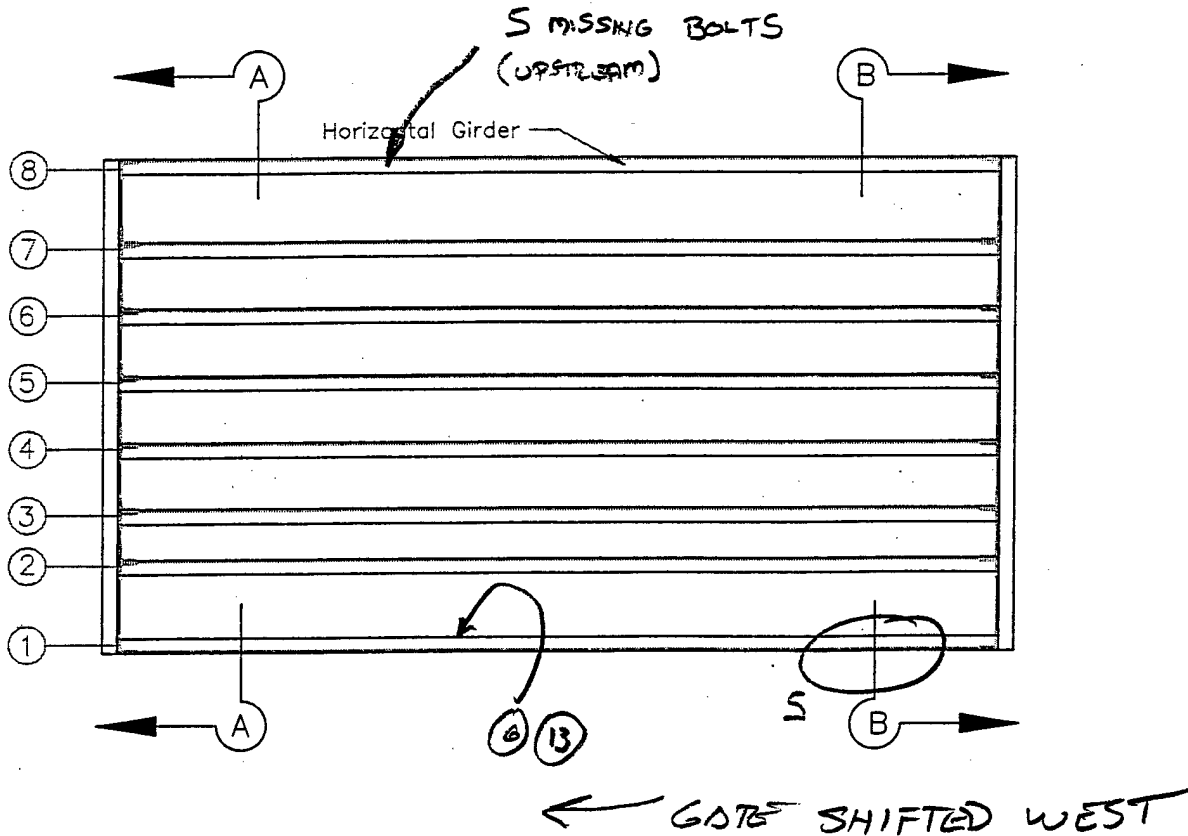

Member	Type	Depth d		Web t _w		Flange			
		Plan (in)	Measured (in)	Plan (in)	Measured (in)	b _f		t _f	
						Plan (in)	Measured (in)	Plan (in)	Measured (in)
Horiz. Girder 8	C 15 x 40	15	15	9/16	9/16	3 1/2	3 3/8	5/8	
Horiz. Girder 7	C 15 x 40	15	15	9/16	9/16	3 1/2	3 3/8	5/8	
Horiz. Girder 6	C 15 x 40	15	15	9/16	9/16	3 1/2	3 3/8	5/8	
Horiz. Girder 5	C 15 x 40	15	15	9/16	9/16	3 1/2	3 3/8	5/8	
Horiz. Girder 4	C 15 x 40	15	15	9/16	9/16	3 1/2	3 3/8	5/8	
Horiz. Girder 3	C 15 x 40	15	15	9/16	9/16	3 1/2	3 3/8	5/8	
Horiz. Girder 2	C 15 x 40	15	15	9/16	9/16	3 1/2	3 3/8	5/8	
Horiz. Girder 1	C 15 x 40	15	15	9/16	9/16	3 1/2	3 3/8	5/8	

5) BOTTOM SEAL @ SPICE, CONDITION TYP

6) DEBRIS, EVD, STANDING WATER, CLOGGED DRAIN HOLES (TYP)
 ALTERNATING BOLTS TO BOTTOM SEEDL MISSING (13)

Gate No. _____ Left Elevation B-B

*NORTH
 RADIAL
 gate*

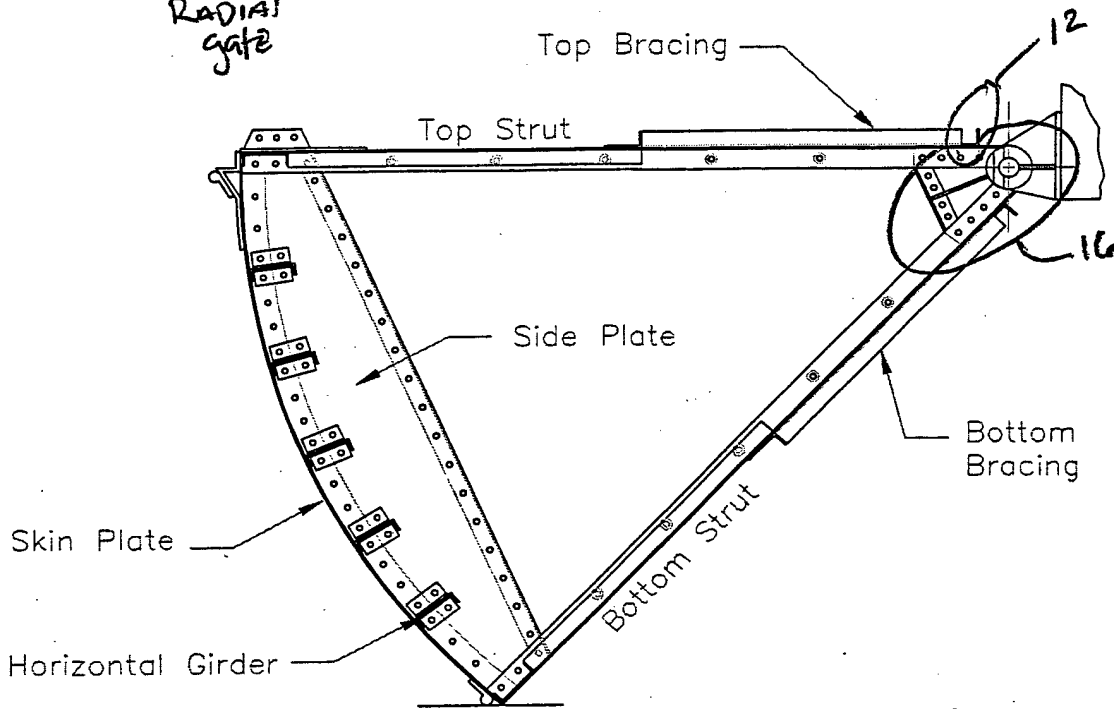

Member	Type	Depth		Web		Flange			
		d		t _w		b _r		t _f	
		Plan (in)	Measured (in)	Plan (in)	Measured (in)	Plan (in)	Measured (in)	Plan (in)	Measured (in)
Top Strut	2-L 4x4x3/8	4	4	3/8	3/8	4	4	3/8	---
Bottom Strut	2-L 4x4x3/8	4	4	3/8	3/8	4	4	3/8	---

6-ID

12 TYP Cable Connections

16. Inside of left terminus

Gate No. NORTH Top and Bottom Bracing

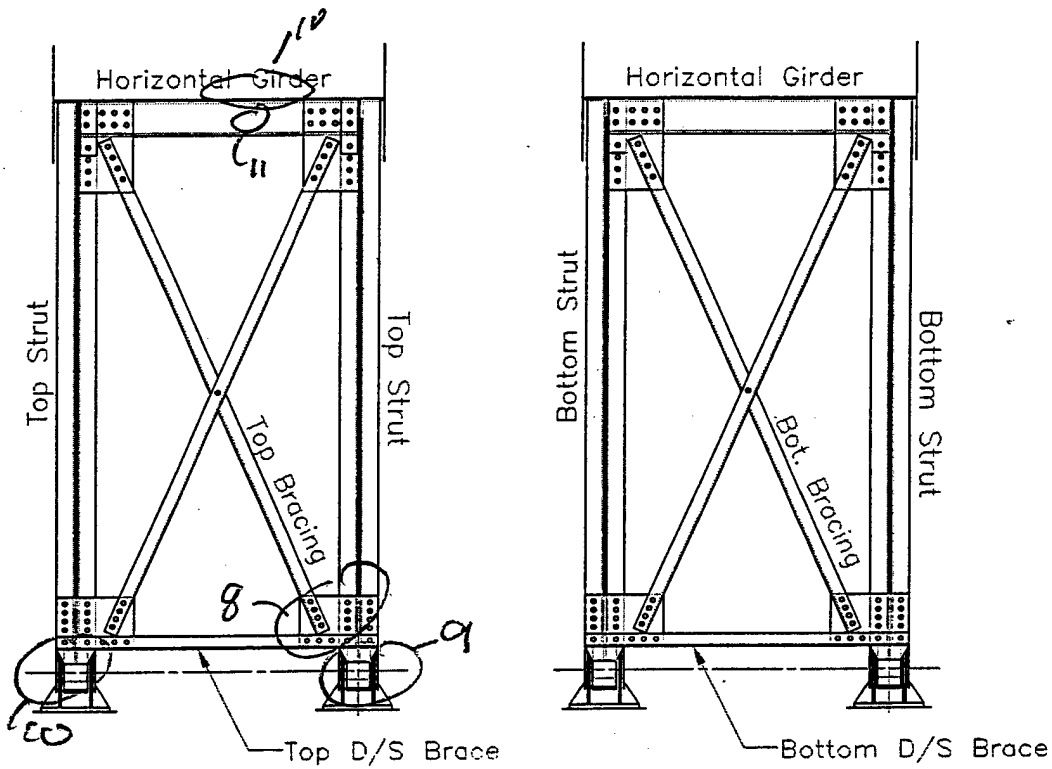

Member	Type	Depth		Web		Flange			
		d		t _w		b _f		t _f	
		Plan (in)	Measured (in)	Plan (in)	Measured (in)	Plan (in)	Measured (in)	Plan (in)	Measured (in)
Top Bracing	L 3 x 3 x 3/8	3	3	3/8	3/8	3	3		
Top D/S Brace	L 3 x 3 x 3/8	3	3	3/8	3/8	3	3		
Bot. Bracing	L 3 x 3 x 3/8	3	3	3/8	3/8	3	3		
Bot D/S Brace	L 3 x 3 x 3/8	3	3	3/8	3/8	3	3		

8. ~~WISSE~~ PIT Part $\approx 1/4'$ 9, 10 FRUCTIONS
 11. SEAL Bolts Cut typ. of all
 12. INDENTION from something DROPPED 1/2"

Gate No. NORTH Downstream Elevation

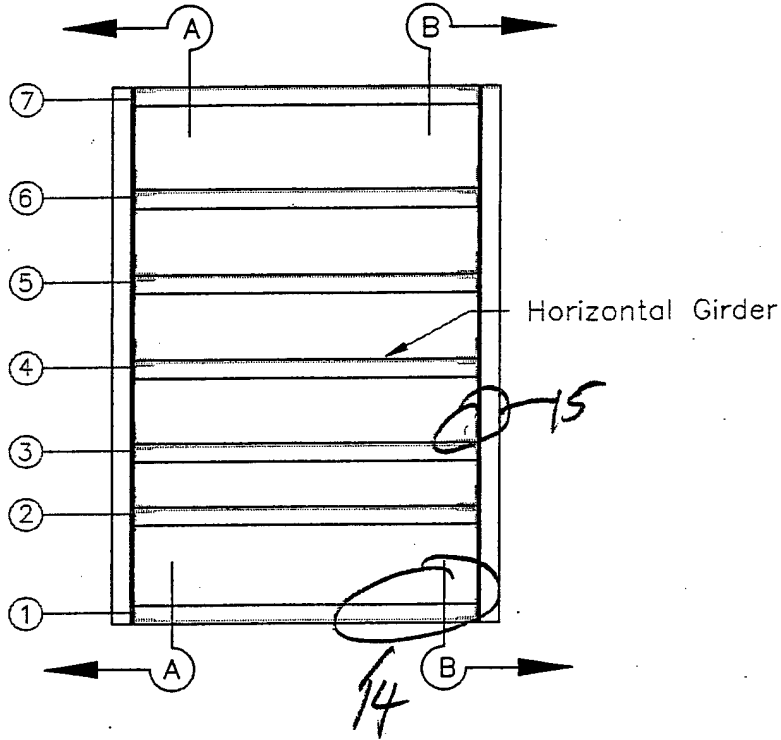

Member	Type	Depth d		Web t _w		Flange			
		Plan (in)	Measured (in)	Plan (in)	Measured (in)	b _r		t _r	
						Plan (in)	Measured (in)	Plan (in)	Measured (in)
Horiz. Girder 7	C 8 x 11.5	8	8	1/4		2 1/4	2 1/4	3/8	3/8
Horiz. Girder 6	C 8 x 11.5	8	8	1/4		2 1/4	2 3/16	3/8	
Horiz. Girder 5	C 8 x 11.5	8		1/4		2 1/4		3/8	
Horiz. Girder 4	C 8 x 11.5	8		1/4		2 1/4		3/8	
Horiz. Girder 3	C 8 x 11.5	8		1/4		2 1/4		3/8	
Horiz. Girder 2	C 8 x 11.5	8		1/4		2 1/4		3/8	
Horiz. Girder 1	C 8 x 11.5	8		1/4		2 1/4		3/8	

7. Gate Face From top
 14. Both Girders Light to moderate Rust
 15. Top Girder Connection

HDR Engineering, Inc.
Corp of Engineers - Walla Walla
Mill Creek Dam - 6' x 8' Gates

Inspection Team SMP TDB
Weather _____

Date 9/14/00
Sheet 5

Gate No. NORTH Upstream Elevation

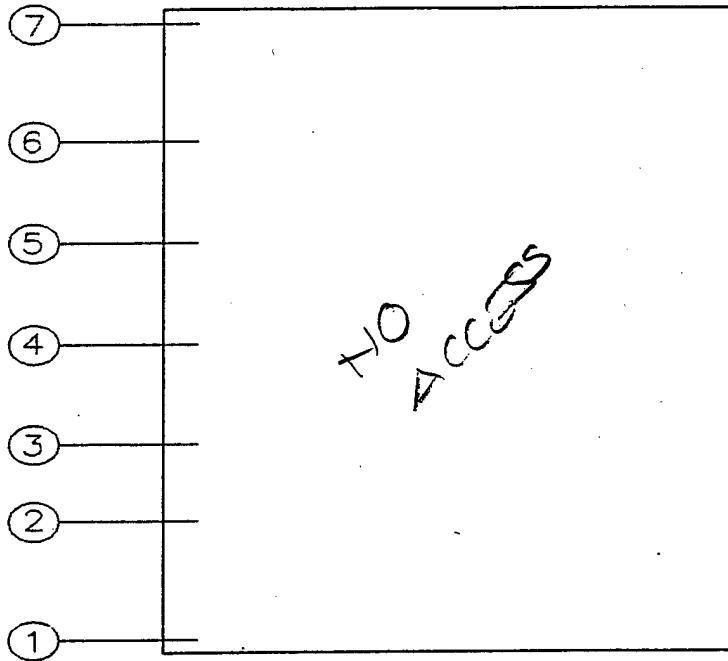

Horizontal lines for data entry.

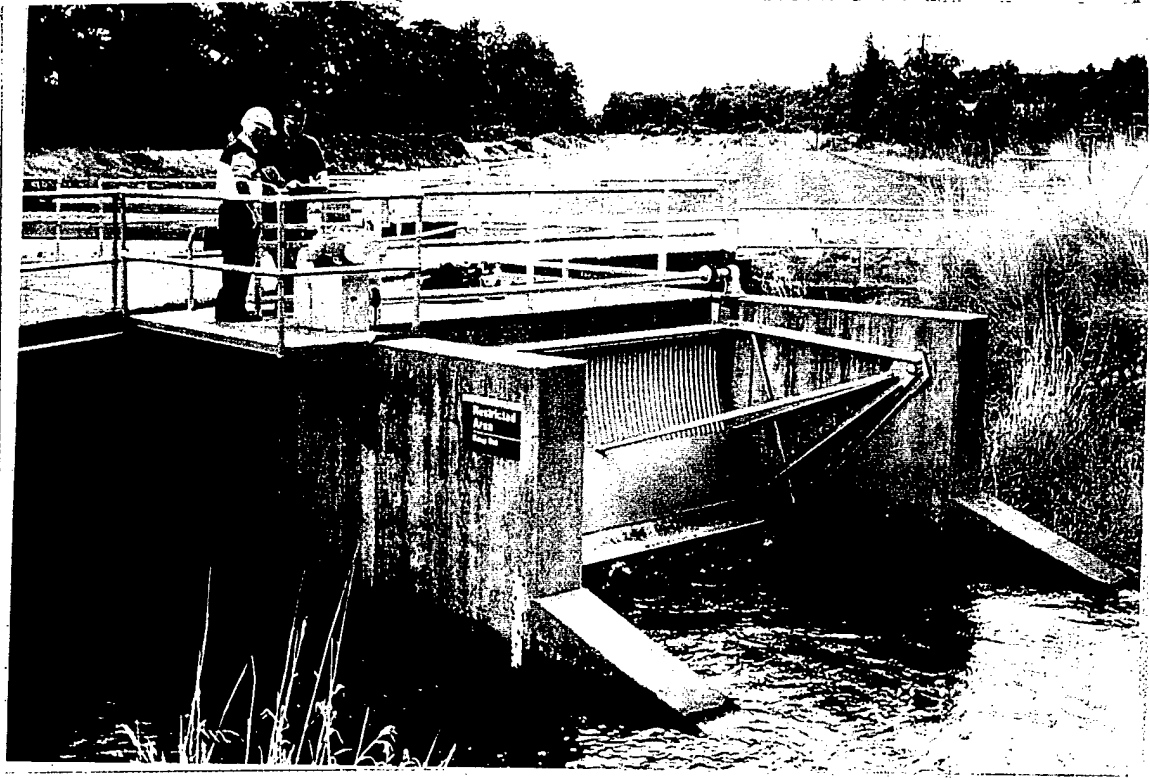

Mill
Creek
Dam
9/19/00
1-1

Armco 6'x14' Gate
Project overview

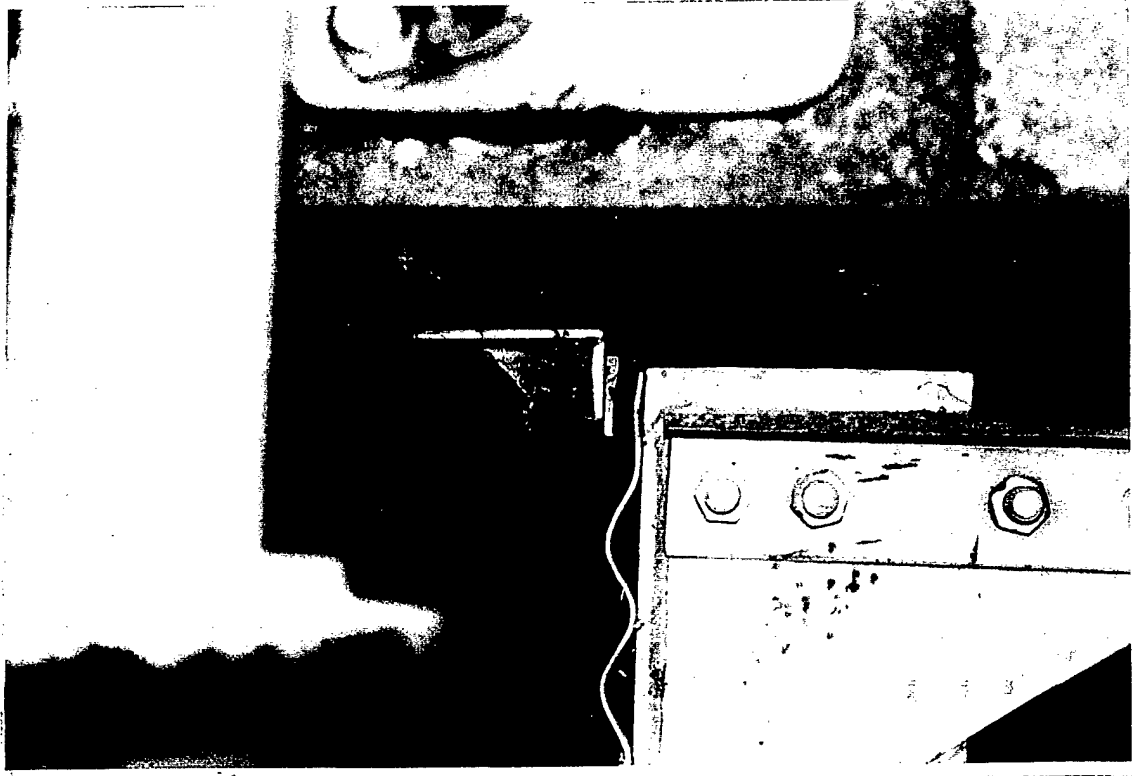

Mill
Creek
Dam
9/19/00
1-2

Armco 6'x14' Gate
Typical. Top left corner of gate at
corrugated skin plate and side seal.

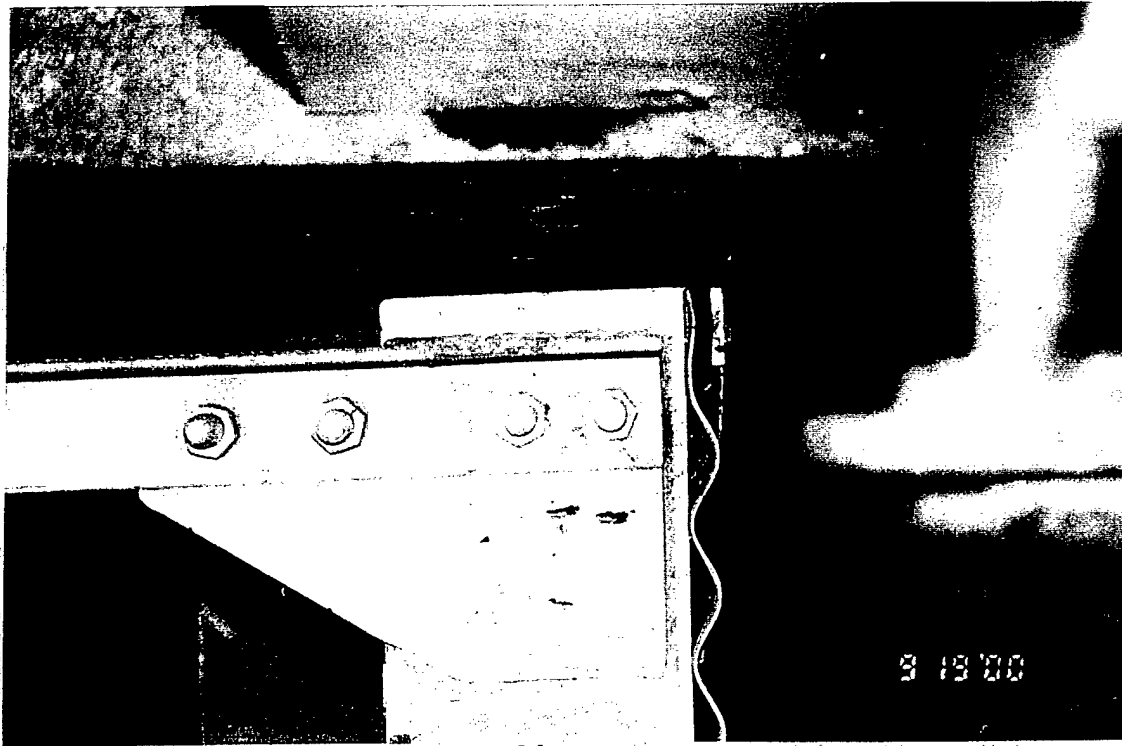

Mill
Creek
Dam

Armco 6'x14' Gate
Typical. Top right corner of gate at
corrugated skin plate and side seal.

9/19/00

1-3



Mill
Creek
Dam

Armco 6'x14' Gate
Typical. Middle radial strut
connection to horizontal girder, right
upstream side of gate.

9/19/00

1-4

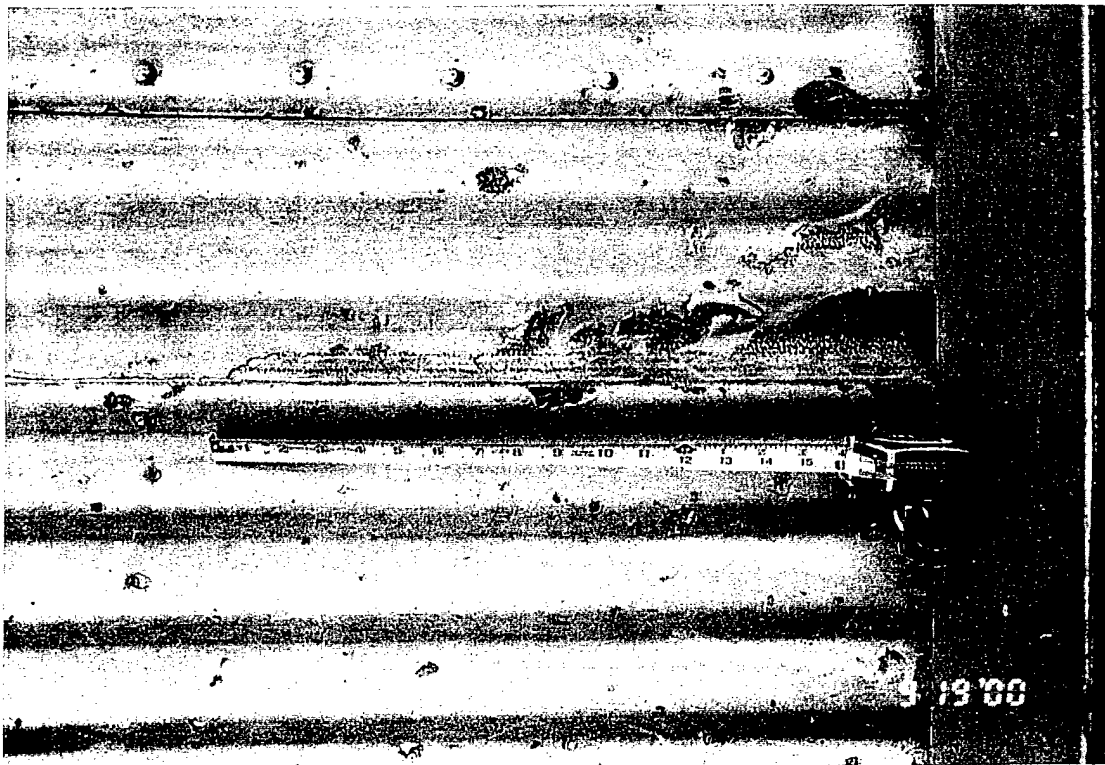

Mill
Creek
Dam

Armco 6'x14' Gate
Corrugated skin plate above strut 3.
Delaminated paint on skin plate.

9/19/00

1-5

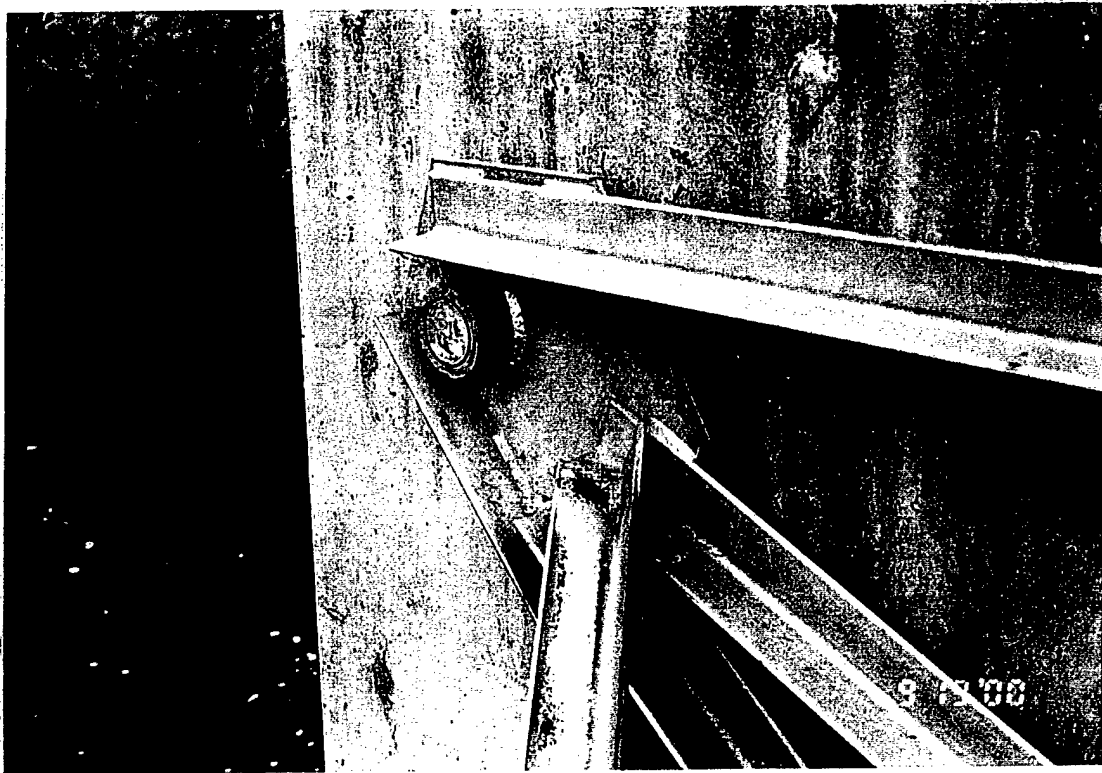

Mill
Creek
Dam

Armco 6'x14' Gate
Right trunnion. Light surface
corrosion on diagonal brace and
trunnion bushing.

9/19/00

1-6

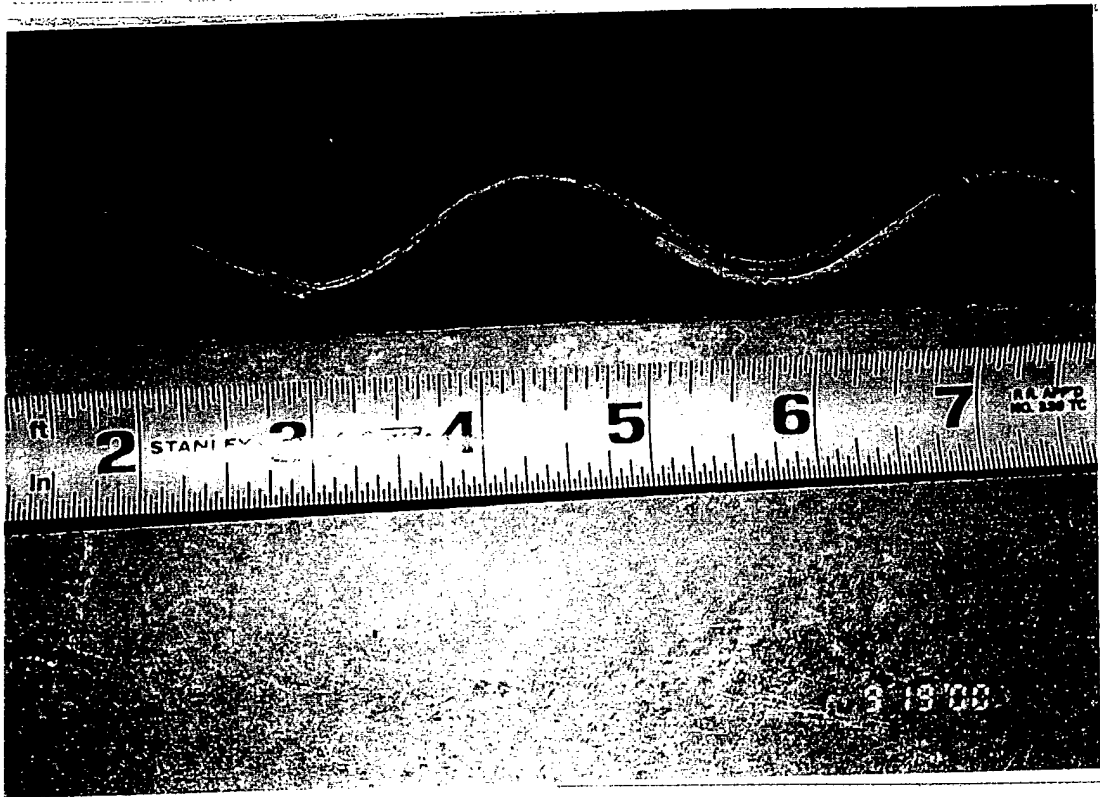

Mill
 Creek
 Dam

 9/19/00
 1-7

Armco 6'x14' Gate
 Close-up skin plate at top horizontal
 girder.

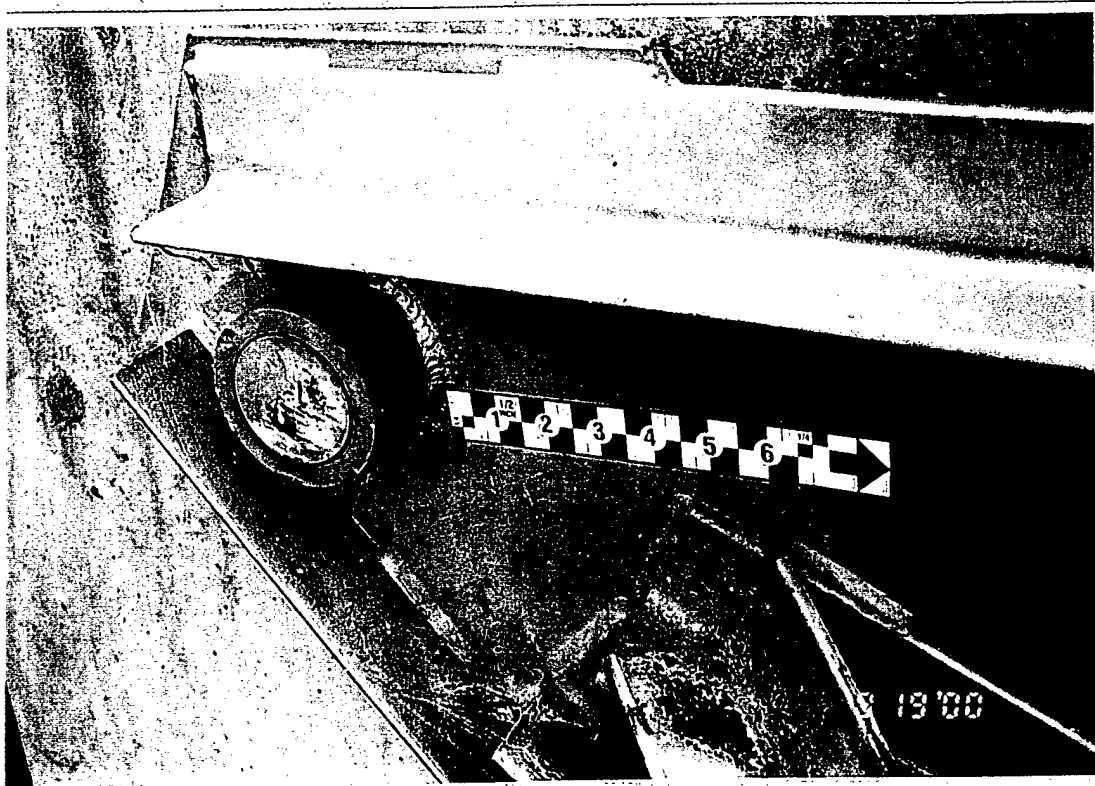

Mill
 Creek
 Dam

 9/19/00
 1-8

Armco 6'x14' Gate
 Close-up right trunnion.

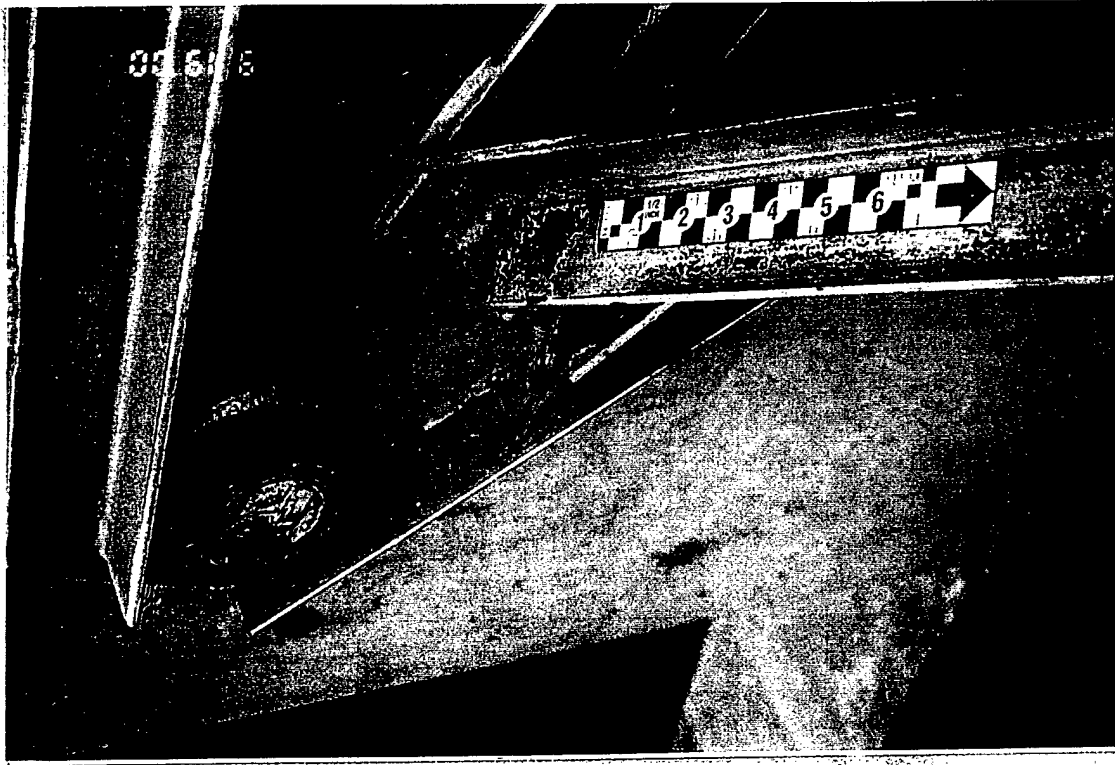

Mill
Creek
Dam

Armco 6'x14' Gate
Close-up right trunnion.

9/19/00

1-9



Mill
Creek
Dam

Armco 6'x14' Gate
Bottom upstream end Strut 1, right
side of gate. Light corrosion on
gusset plate and bolts.

9/19/00

1-10

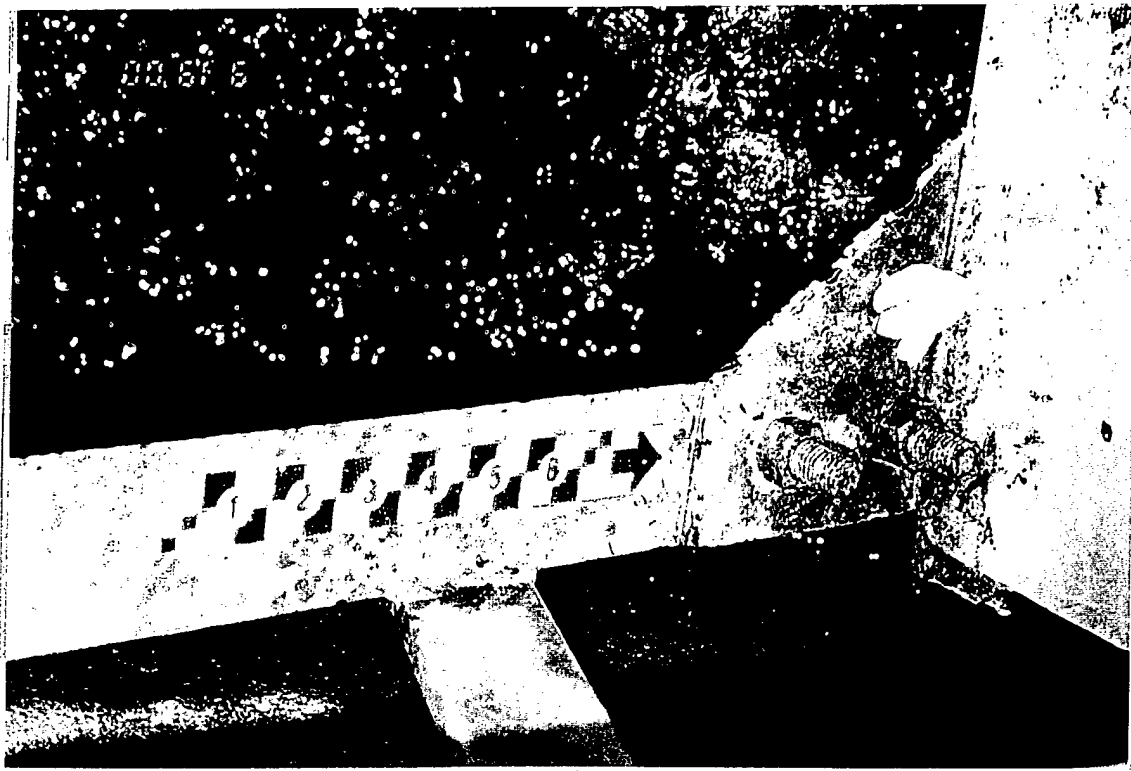

Mill
Creek
Dam
9/19/00
1-11

Armco 6'x14' Gate
Bottom upstream end Strut 1, left
side of gate. Light corrosion on
gusset plate and bolts.

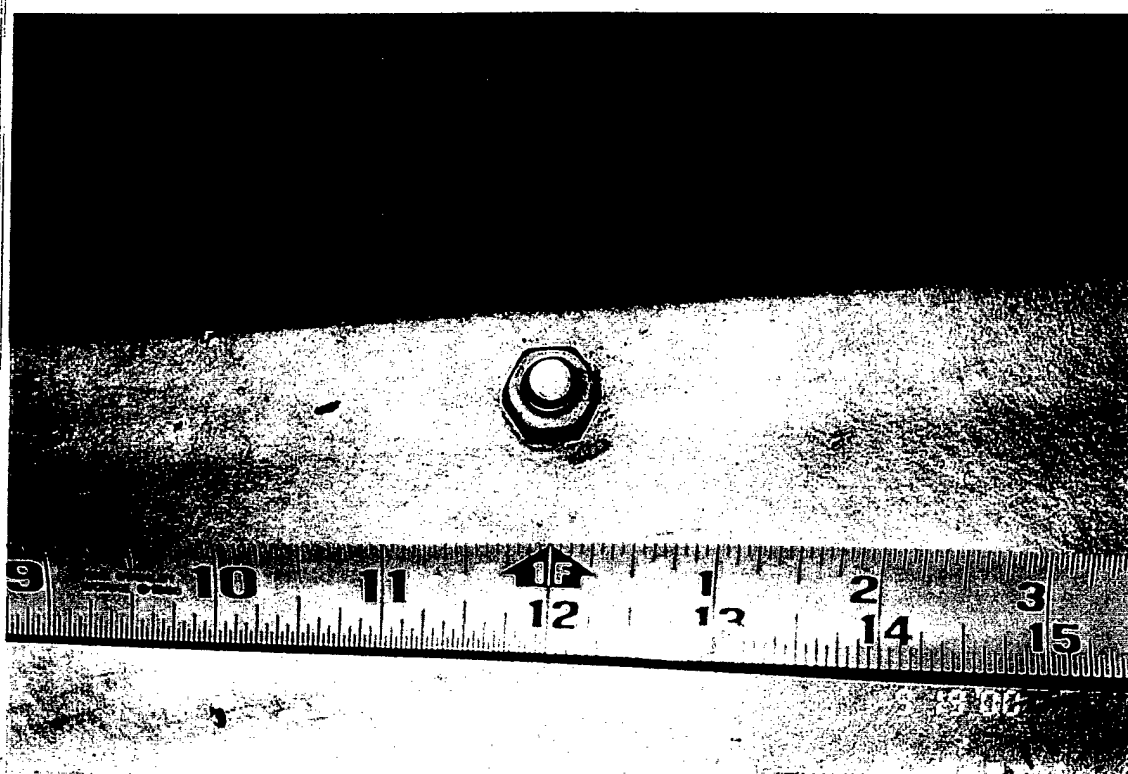

Mill
Creek
Dam
9/19/00
1-12

Armco 6'x14' Gate
Typical condition of bolted
connections.

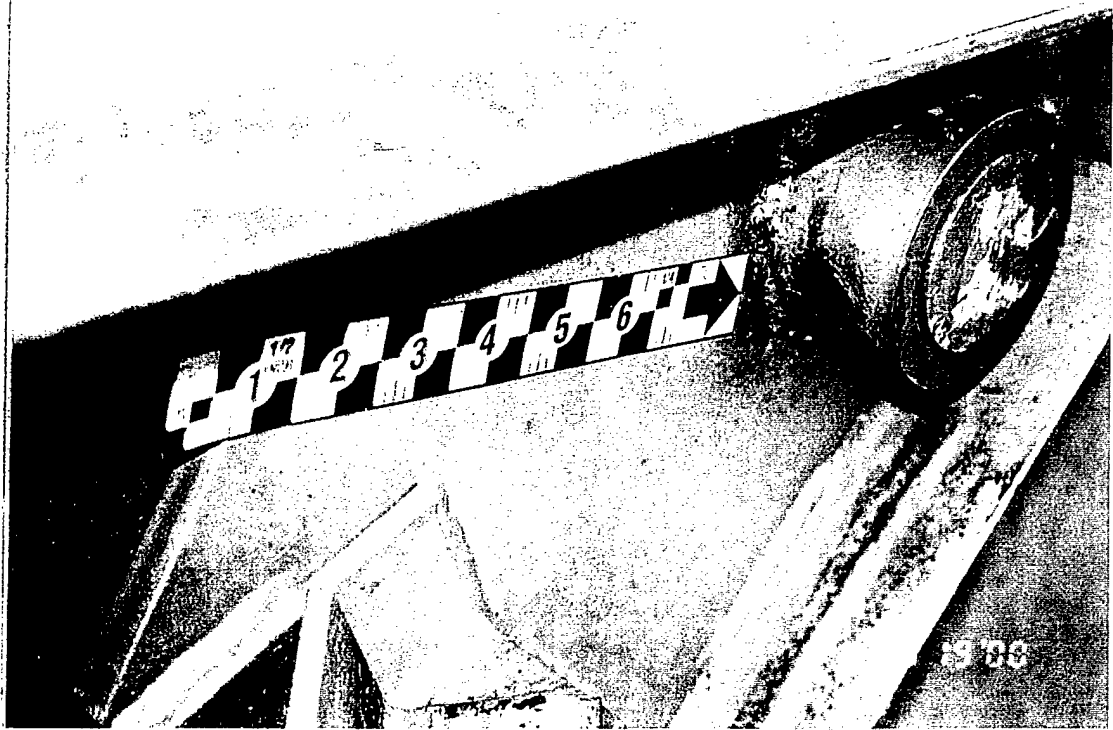

Mill
Creek
Dam

Armco 6'x14' Gate
Left trunnion. Note: lubrication hole
on upstream side of bushing.

9/19/00

1-13

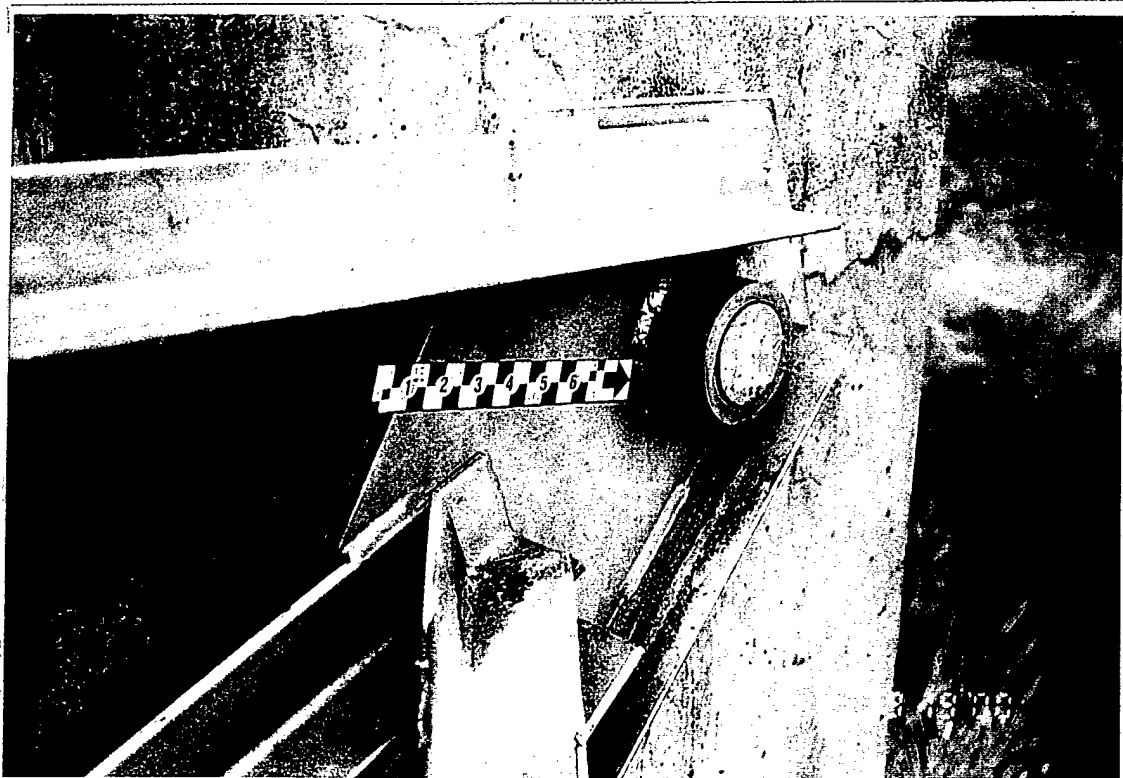

Mill
Creek
Dam

Armco 6'x14' Gate
Left trunnion. Note: lubrication hole
on upstream side of bushing.

9/19/00

1-14

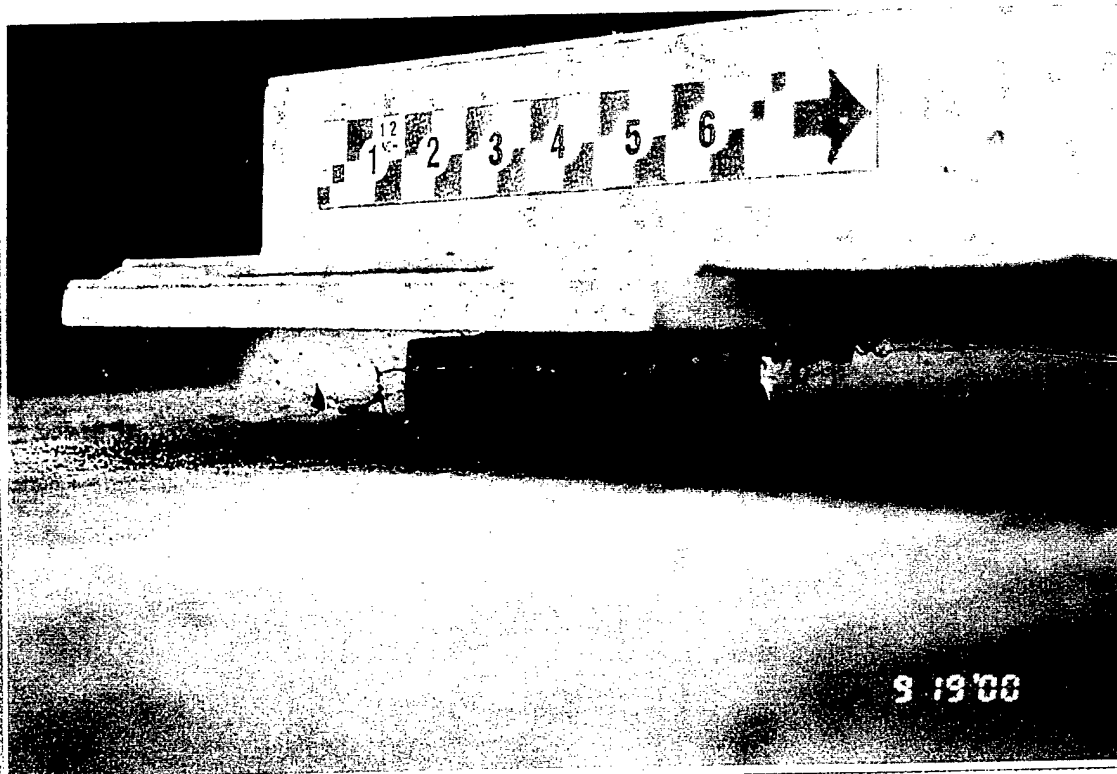

Mill
Creek
Dam
9/19/00
1-15

Armco 6'x14' Gate
Left trunnion looking downstream.
Light corrosion on embedded
trunnion assembly.

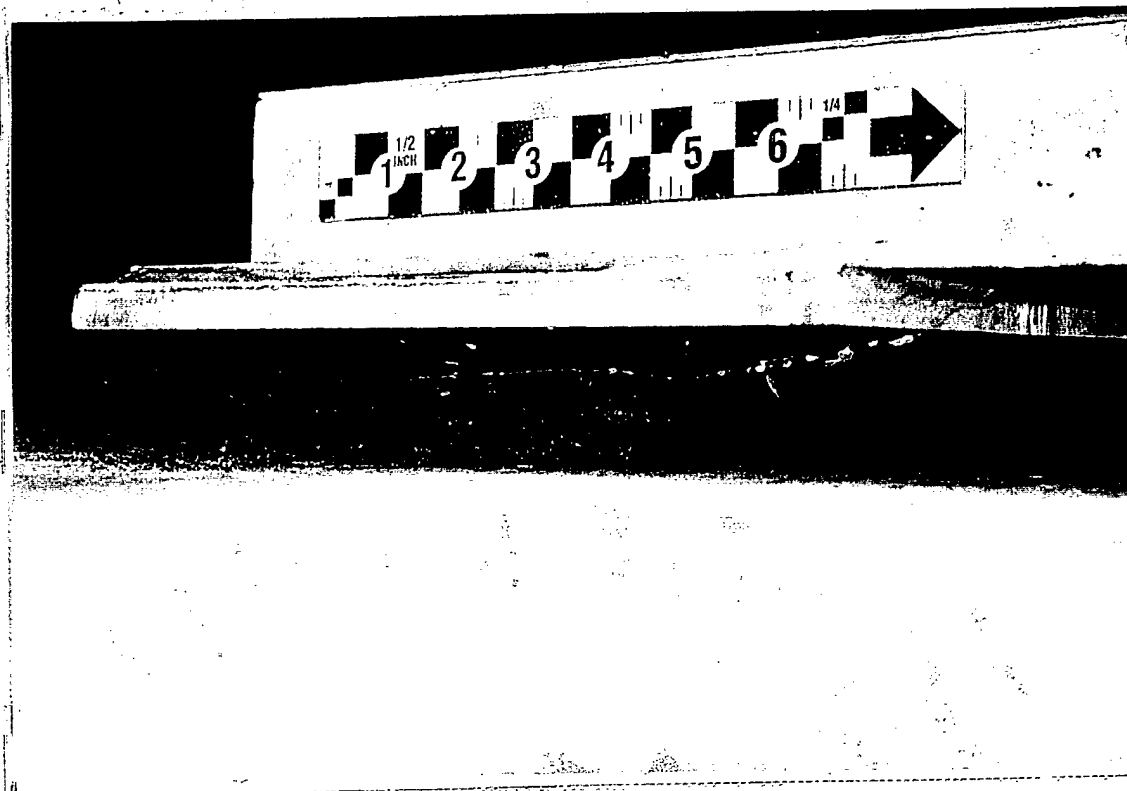

Mill
Creek
Dam
9/19/00
1-16

Armco 6'x14' Gate
Left trunnion looking downstream.
Light corrosion on embedded
trunnion assembly.

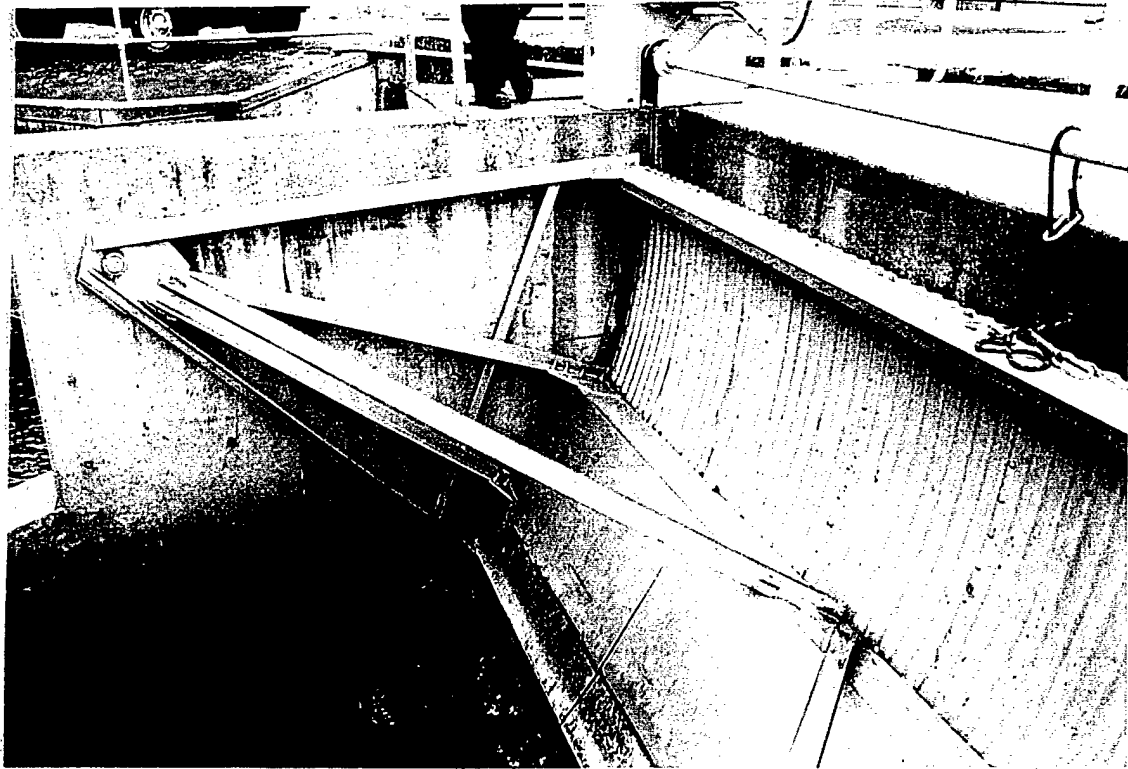

Mill
Creek
Dam

Armco 6'x14' Gate
Typical. Right side frame.

9/19/00

1-17

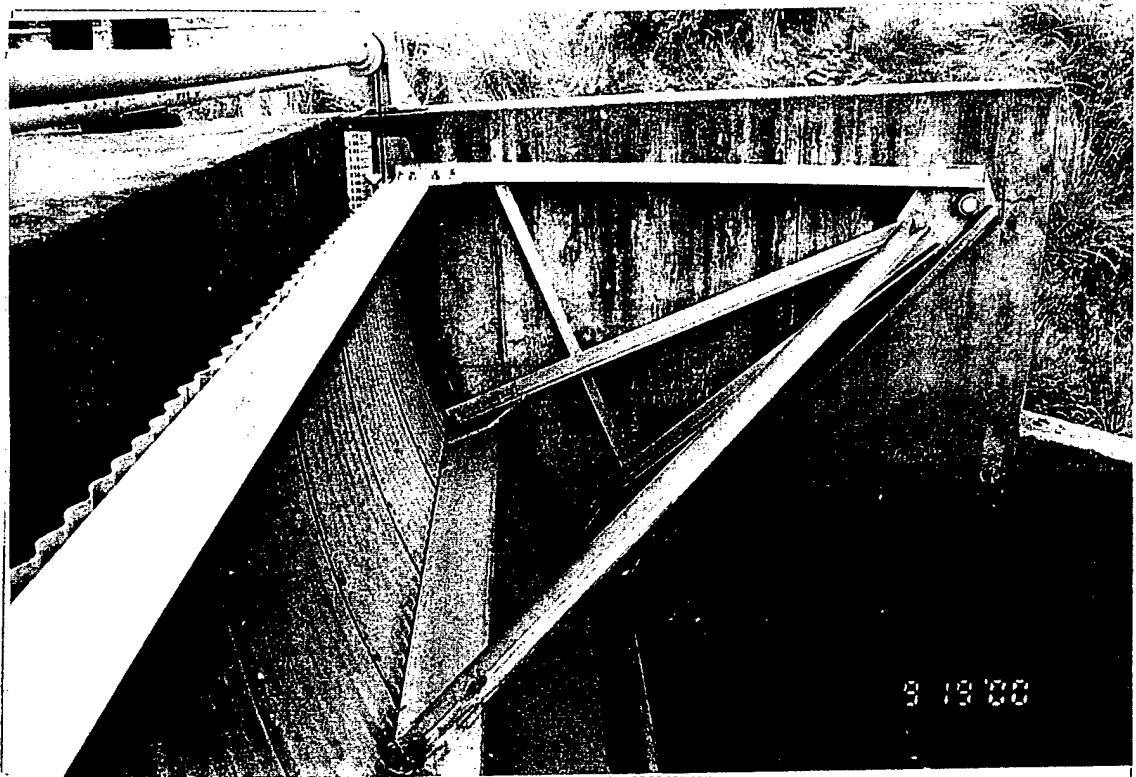

Mill
Creek
Dam

Armco 6'x14' Gate
Typical. Left side frame.

9/19/00

1-18

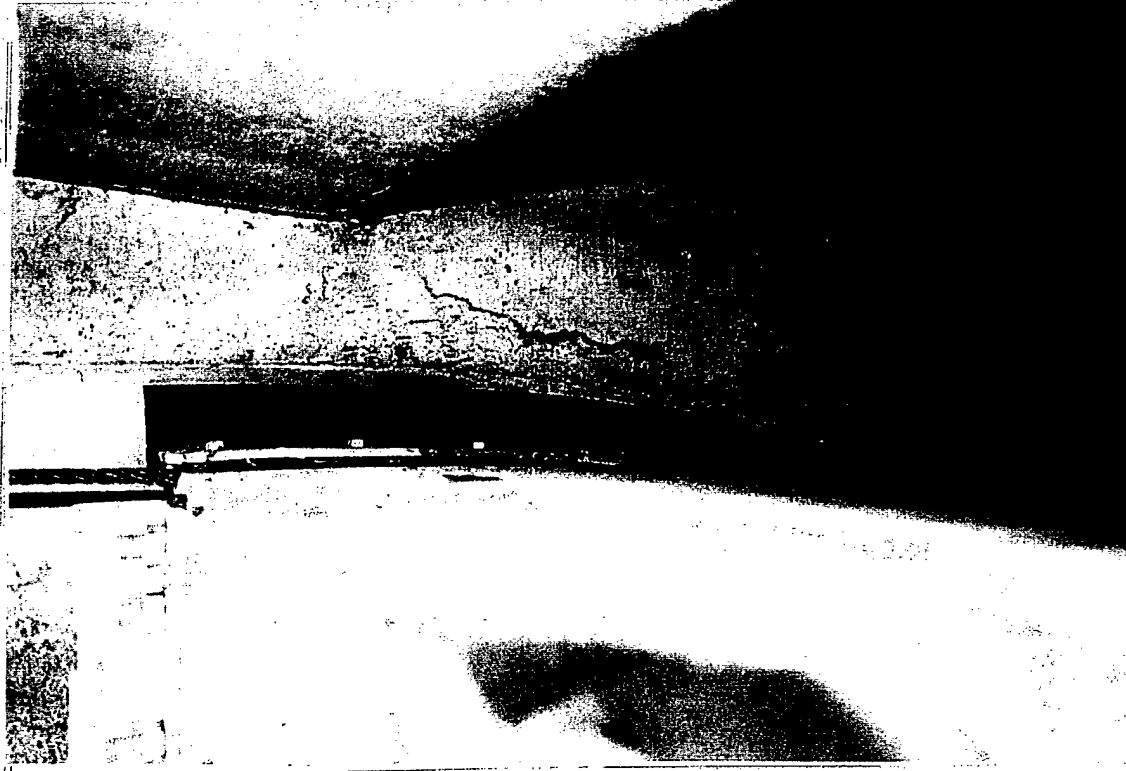

Mill
Creek
Dam

Armco 6'x14' Gate
Right side seal from upstream.

9/19/00

1-19

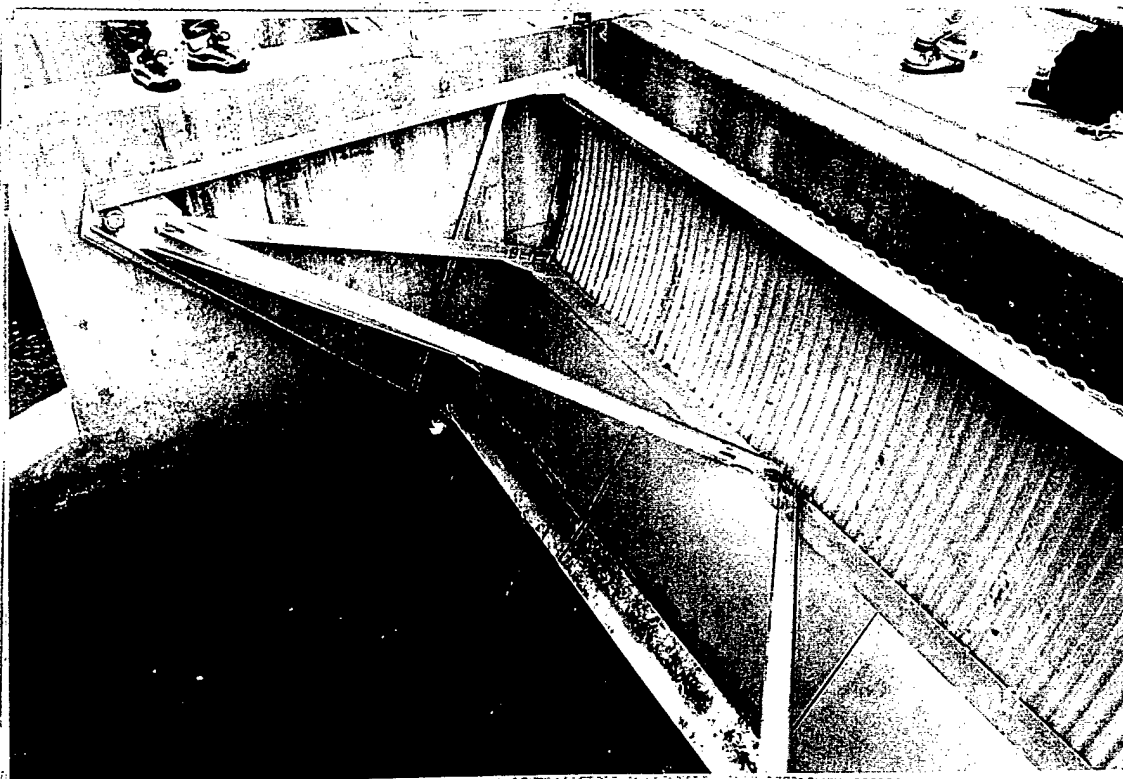

Mill
Creek
Dam

Armco 6'x14' Gate
Typical. Right side frame.

9/19/00

1-20

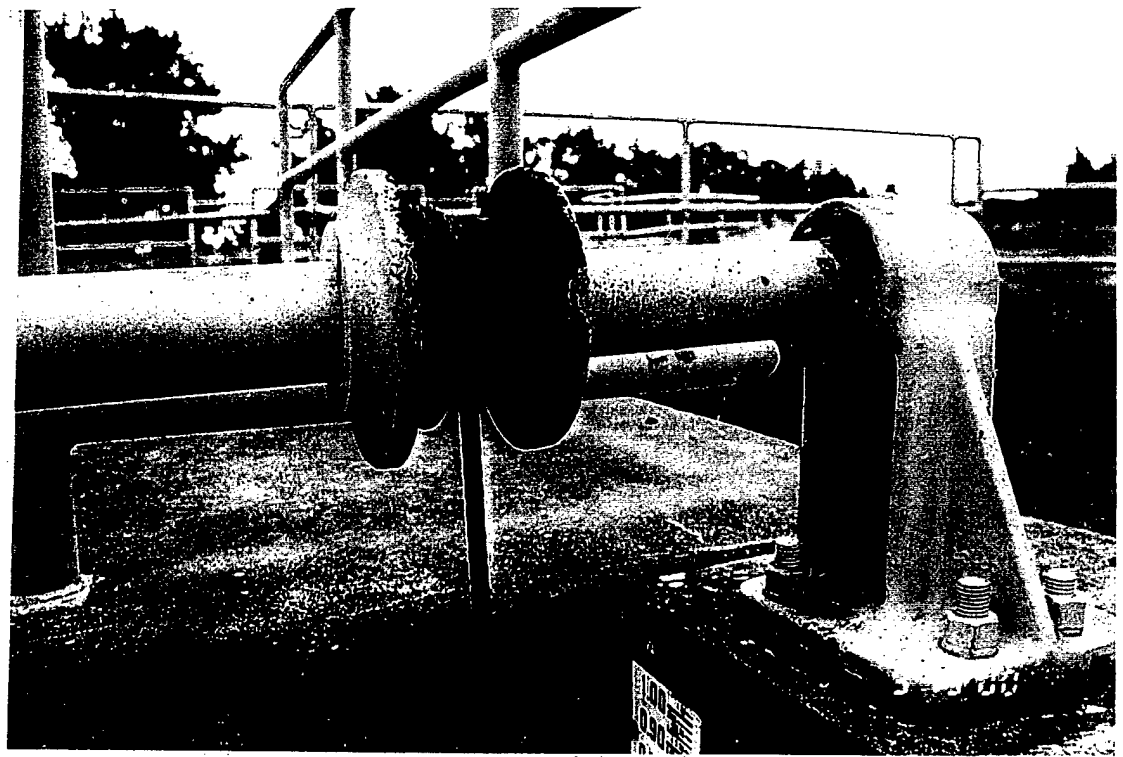

Mill Creek Dam	Armco 6'x14' Gate Left side, hoist torque tube, support bearing and take-up drum. Light corrosion on drum.
9/19/00	
1-21	

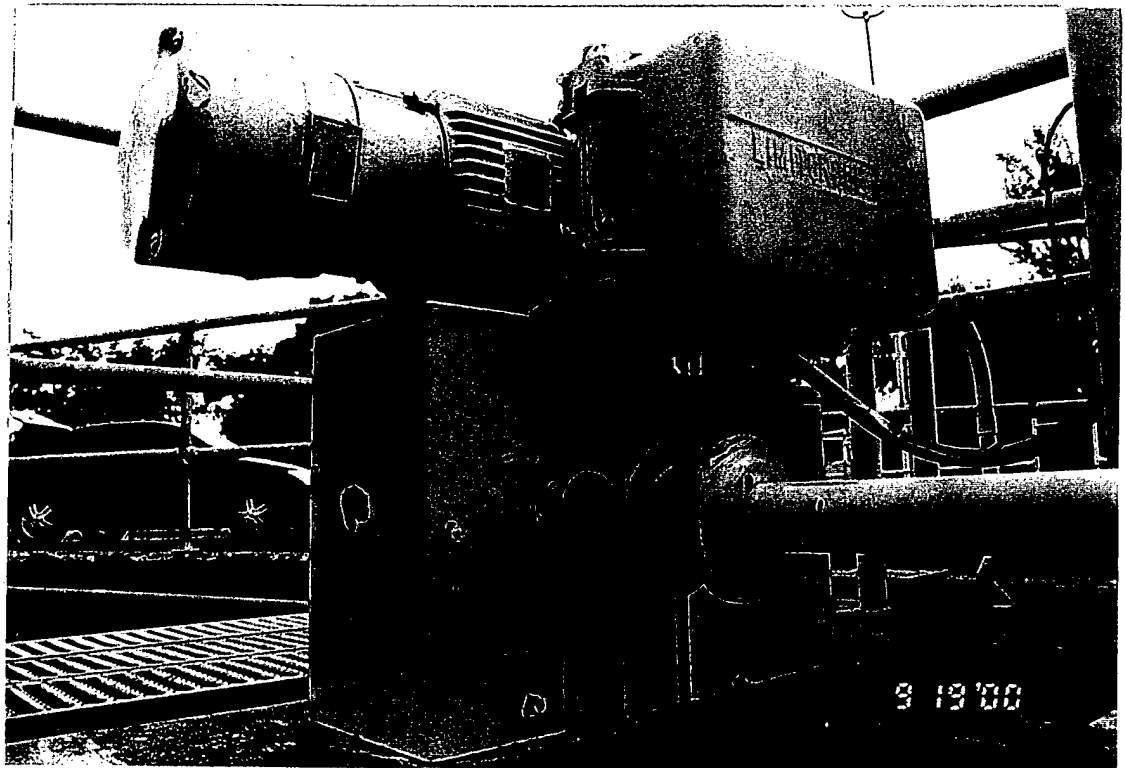

Mill Creek Dam	Armco 6'x14' Gate Hoist motor and right side of torque tube. Light corrosion on take-up drum.
9/19/00	
1-22	

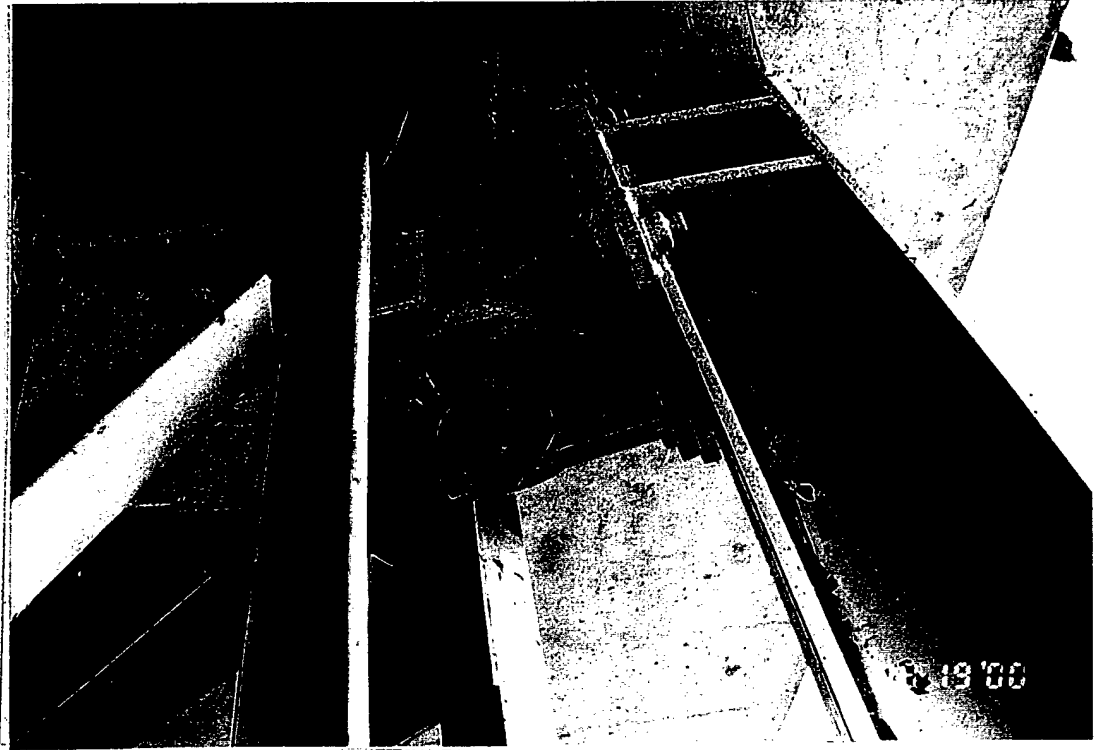

Mill
Creek
Dam

9/19/00

1-1

Gate 1 - 8'x18'
Left trunnion and trunnion beam.
Isolated, light surface corrosion,
debris between flanges of trunnion
beam.

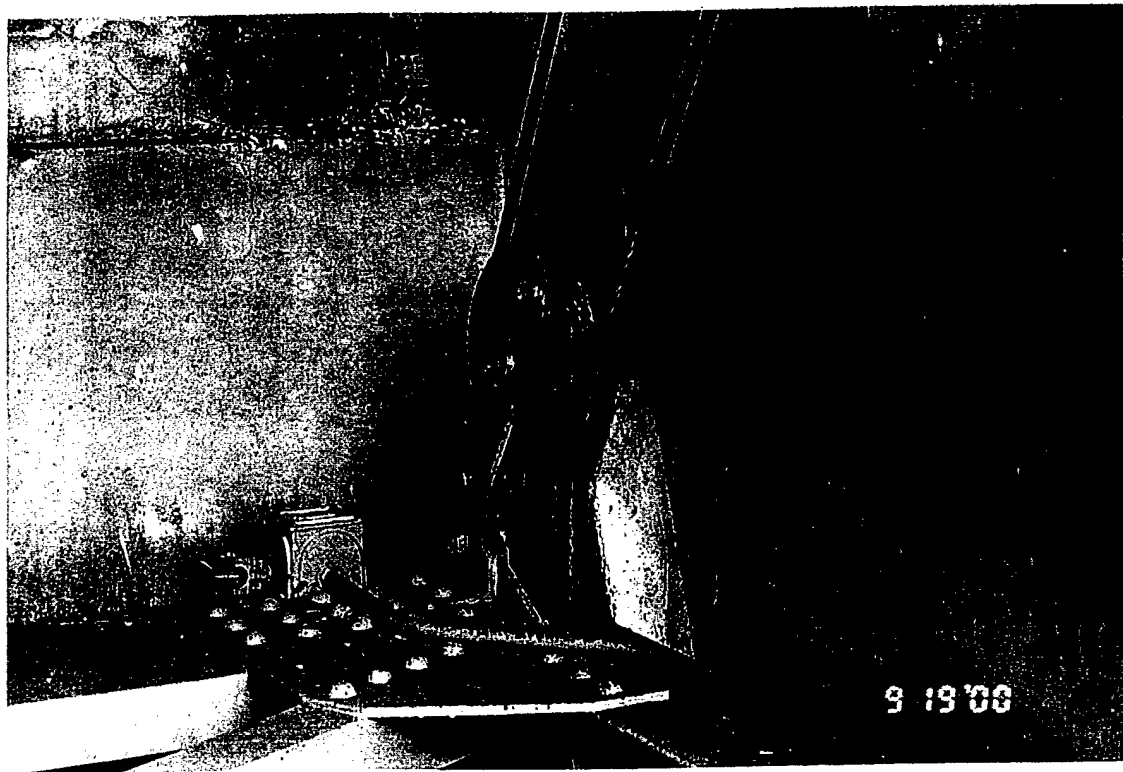

Mill
Creek
Dam

9/19/00

1-2

Gate 1 - 8'x18'
Left hoist reduction pulley. Note:
missing paint on pulley at previous
location of hoist connection.

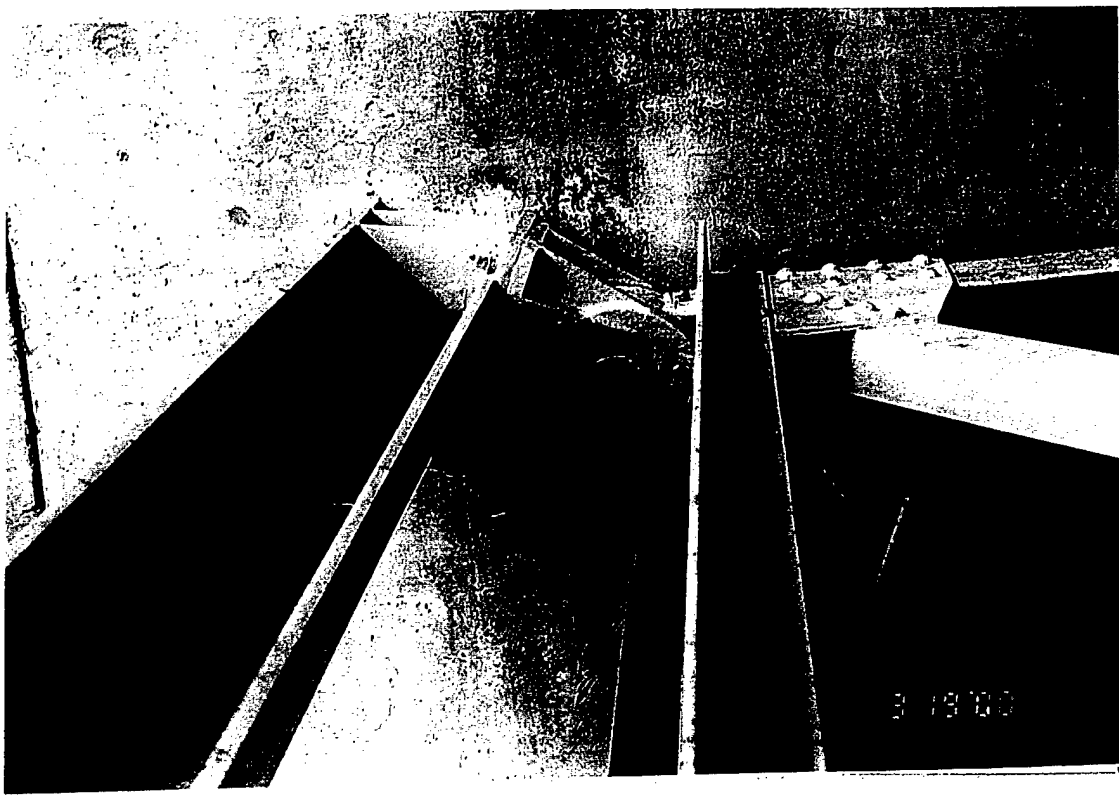

Mill
Creek
Dam
9/19/00
1-3

Gate 1 - 8'x18'
Right trunnion and trunnion beam.
Isolated, light surface corrosion,
debris between flanges of trunnion
beam.

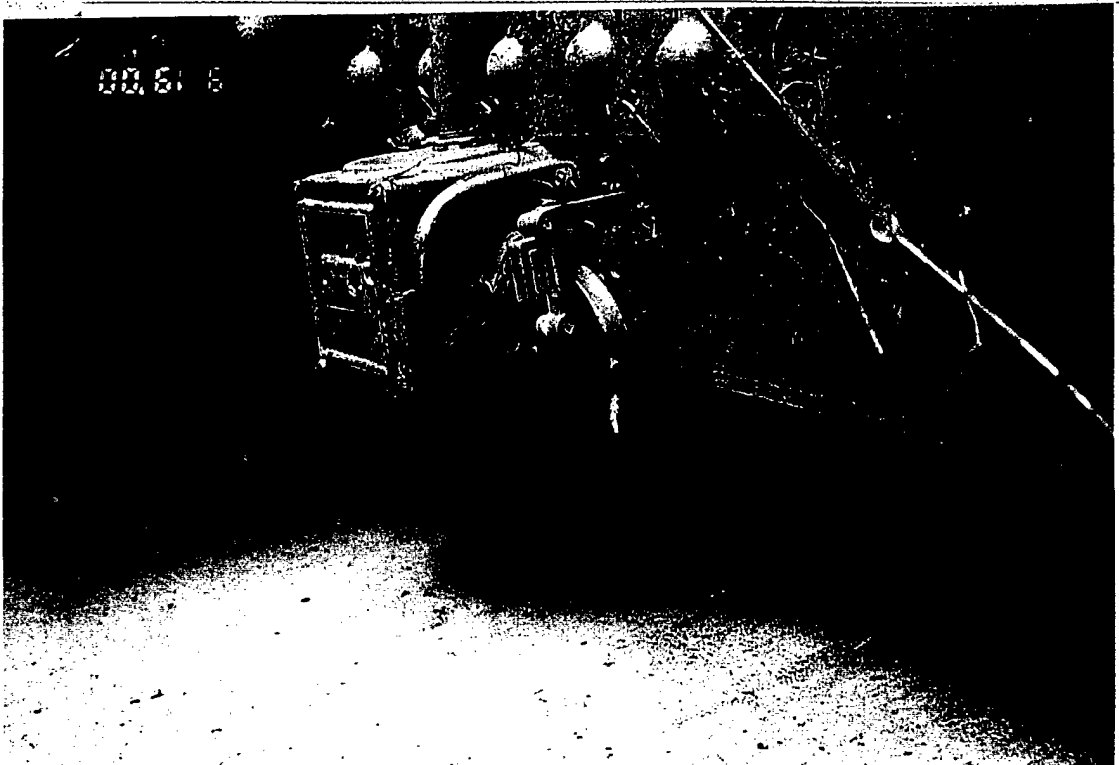

Mill
Creek
Dam
9/19/00
1-4

Gate 1 - 8'x18'
Side seal heater at left, upstream
corner of gate.

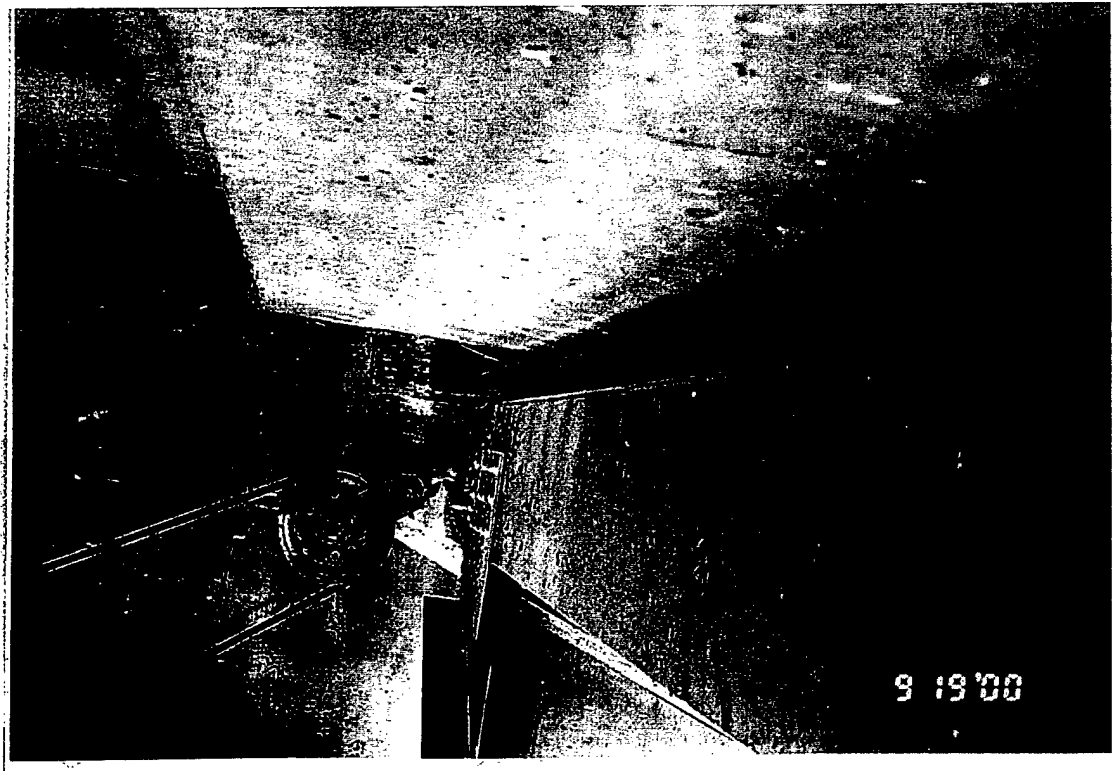

Mill
Creek
Dam
9/19/00
1-5

Gate 1 - 8'x18'
Top of top horizontal girder and right
hoist reduction pulley. Note: missing
paint on pulley at previous location of
hoist connection



Mill
Creek
Dam
9/19/00
1-6

Gate 1 - 8'x18'
Typical. Top cross bracing.

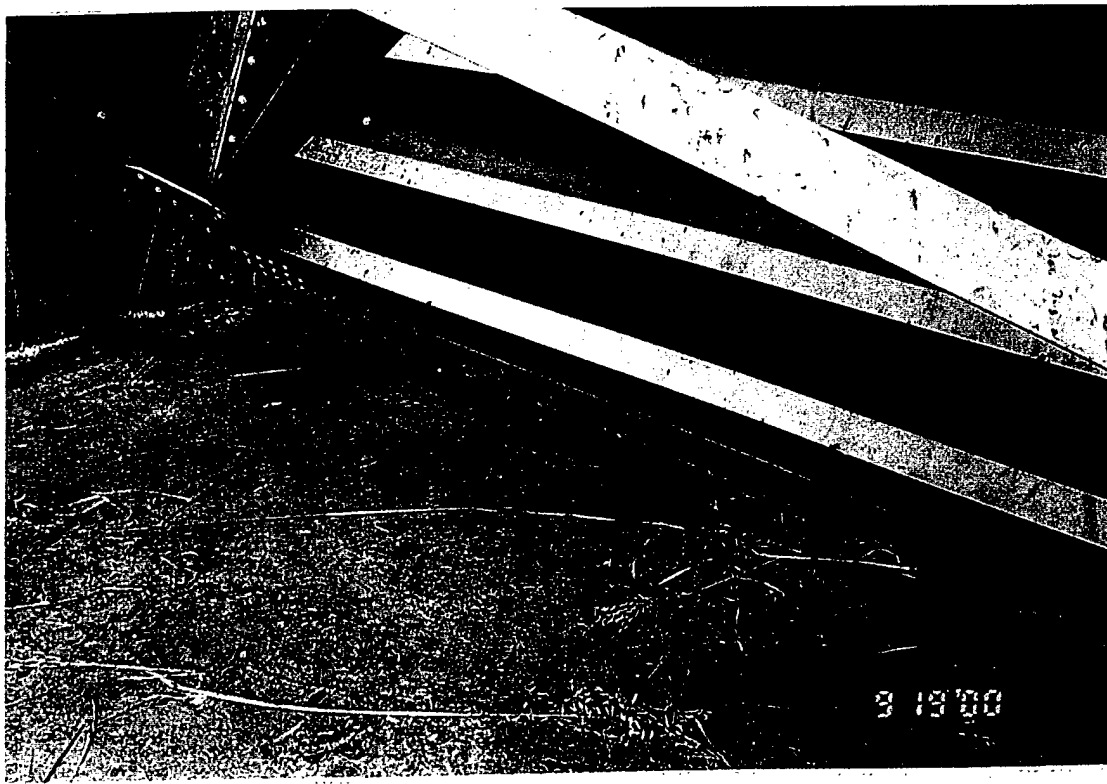

Mill
Creek
Dam
9/19/00
1-7

Gate 1 - 8'x18'
Typical. Bottom timber bumpers,
spillway and bottom horizontal girder,
looking upstream.

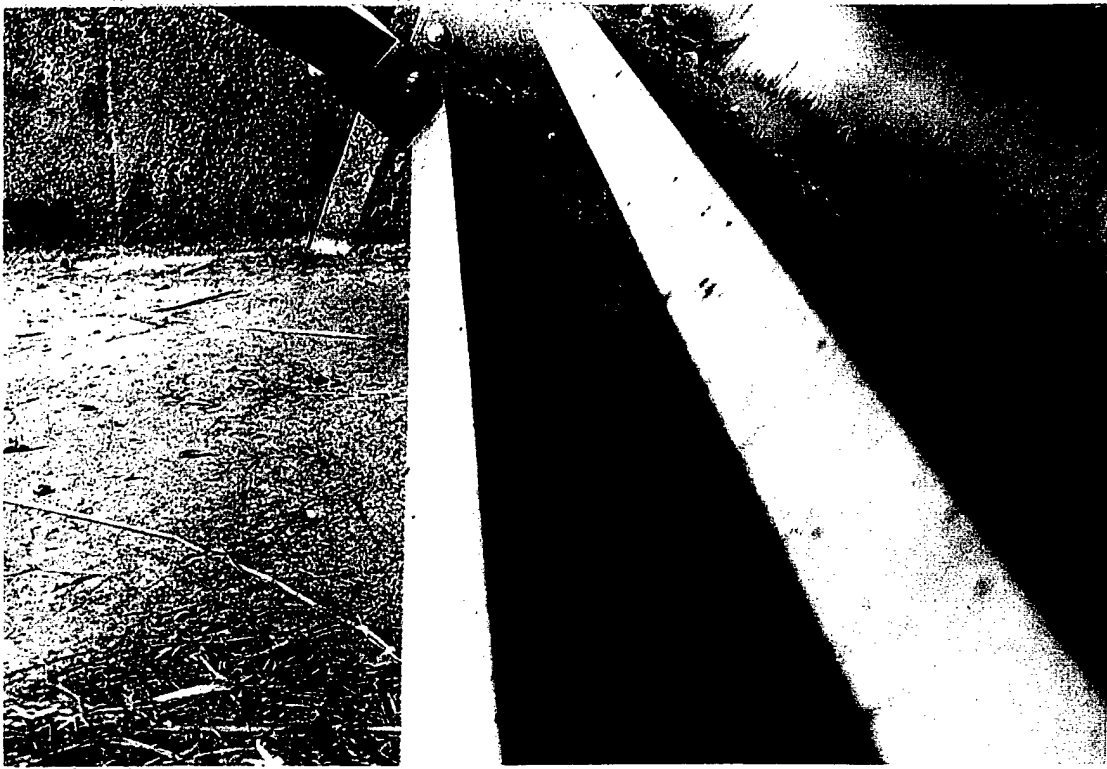

Mill
Creek
Dam
9/19/00
1-8

Gate 1 - 8'x18'
Inside of bottom horizontal girder
looking toward right frame. Debris
and evidence of standing water on
girder web and skin plate.



Mill
Creek
Dam
9/19/00
1-9

Gate 1 - 8'x18'
Bottom horizontal girder, looking
upstream. Debris and clogged drain
holes.



Mill
Creek
Dam
9/19/00
1-10

Gate 1 - 8'x18'
Gate overview.



Mill
Creek
Dam

Gate 1 - 8'x18'
Right trunnion. Light surface
corrosion on trunnion pin.

9/19/00

1-11



Mill
Creek
Dam

Gate 1 - 8'x18'
Bottom right corner of gate. Light to
moderate corrosion and deformations
on bottom strut. Splintered timber
bottom seal bumper.

9/19/00

1-12

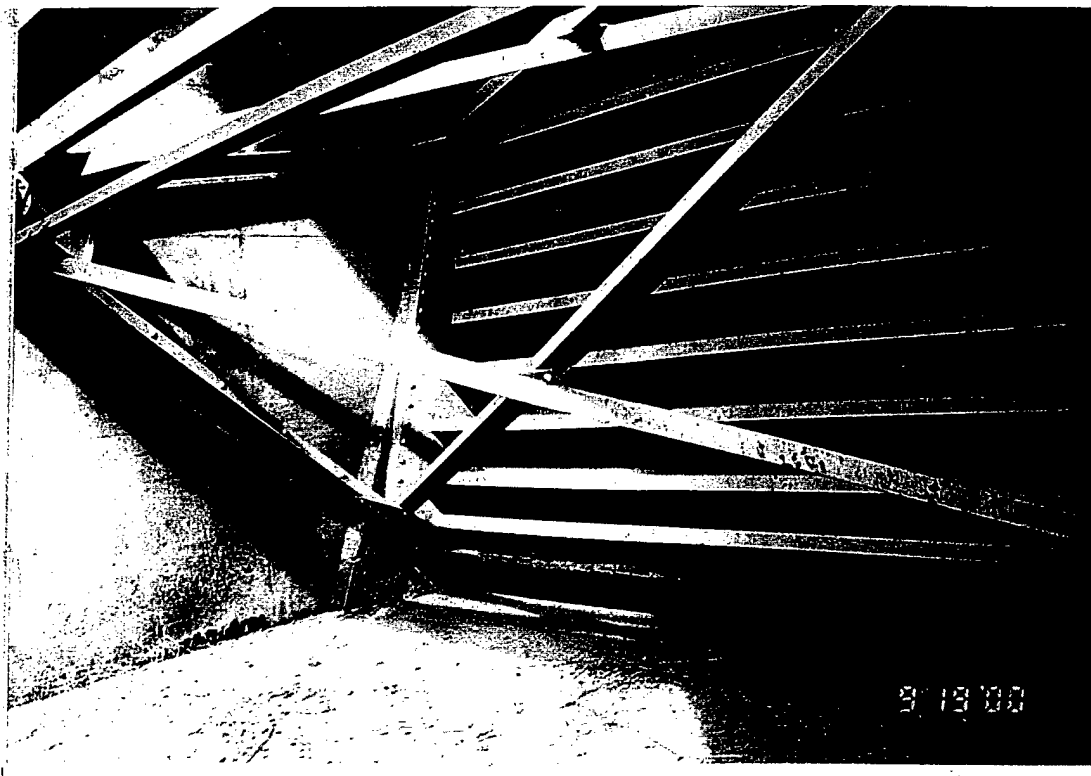

Mill
Creek
Dam

Gate 1 - 8'x18'
Right side frame and gate face,
typical.

9/19/00

1-13



Mill
Creek
Dam

Gate 1 - 8'x18'
Left side frame, bottom strut, in
contact with pier wall.

9/19/00

1-14

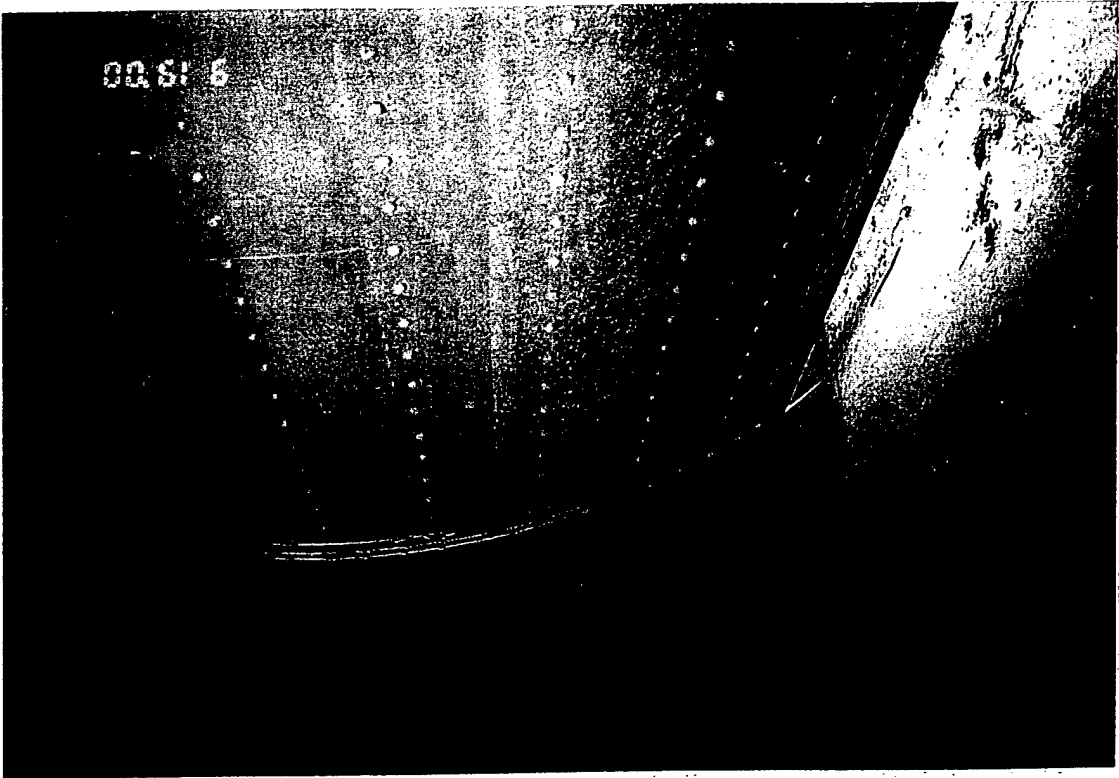

Mill
Creek
Dam

Gate 1 - 8'x18'
Gate face, typical.

9/19/00

1-15

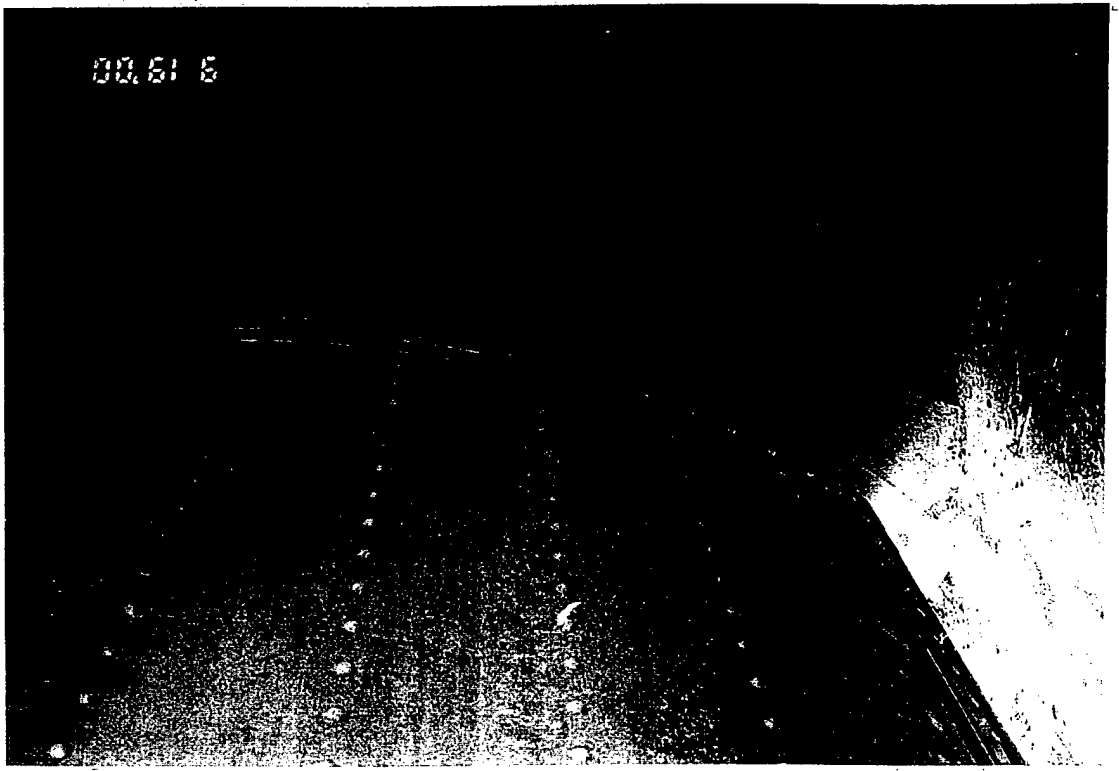

Mill
Creek
Dam

Gate 1 - 8'x18'
Gate face, typical.

9/19/00

1-16

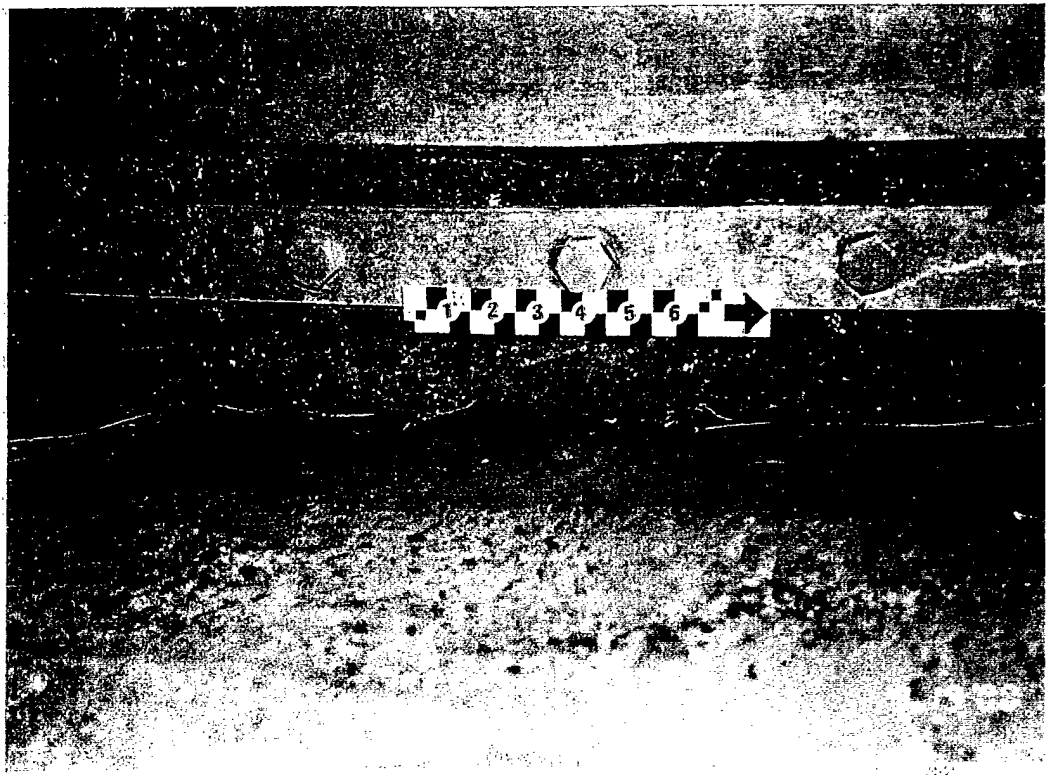

Mill
Creek
Dam

Gate 1 - 8'x18'
Side seal, typical.

9/19/00

1-17

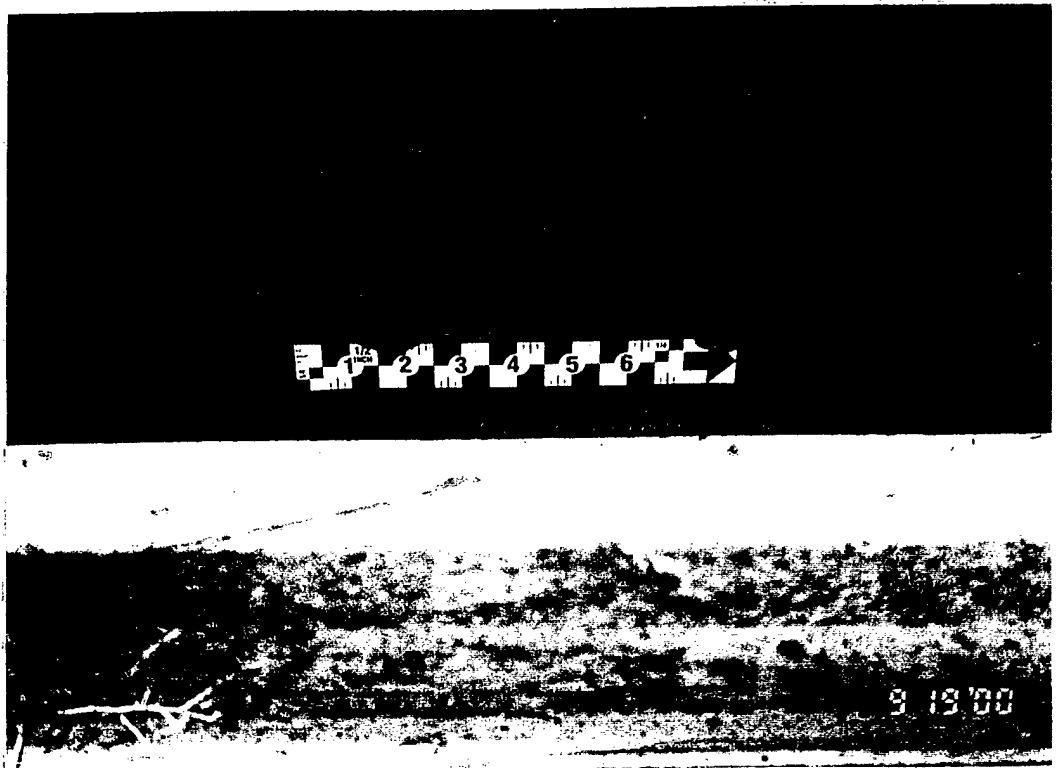

Mill
Creek
Dam

Gate 1 - 8'x18'
Bottom seal and keeper bar, typical.

9/19/00

1-18

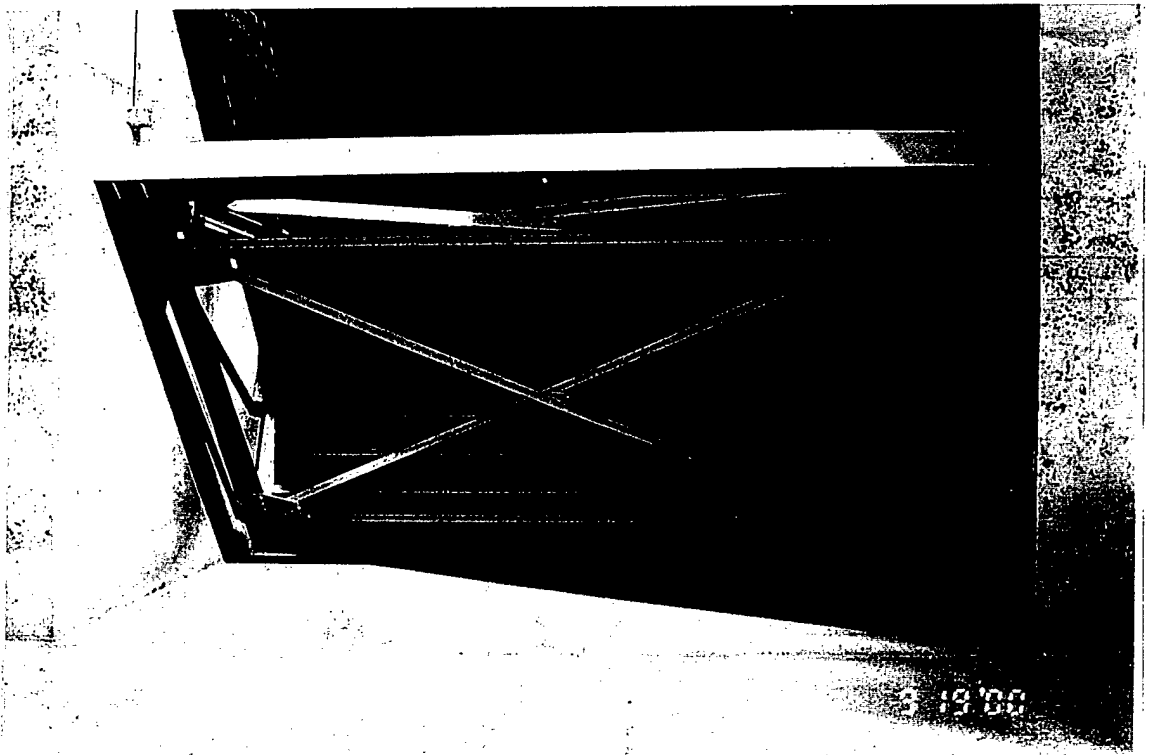

Mill
Creek
Dam

Gate 2 - 8'x18'
Gate overview.

9/19/00

2-1



Mill
Creek
Dam

Gate 2 - 8'x18'
Paint peeling, delamination and light
corrosion on cross bracing, typical.

9/19/00

2-2

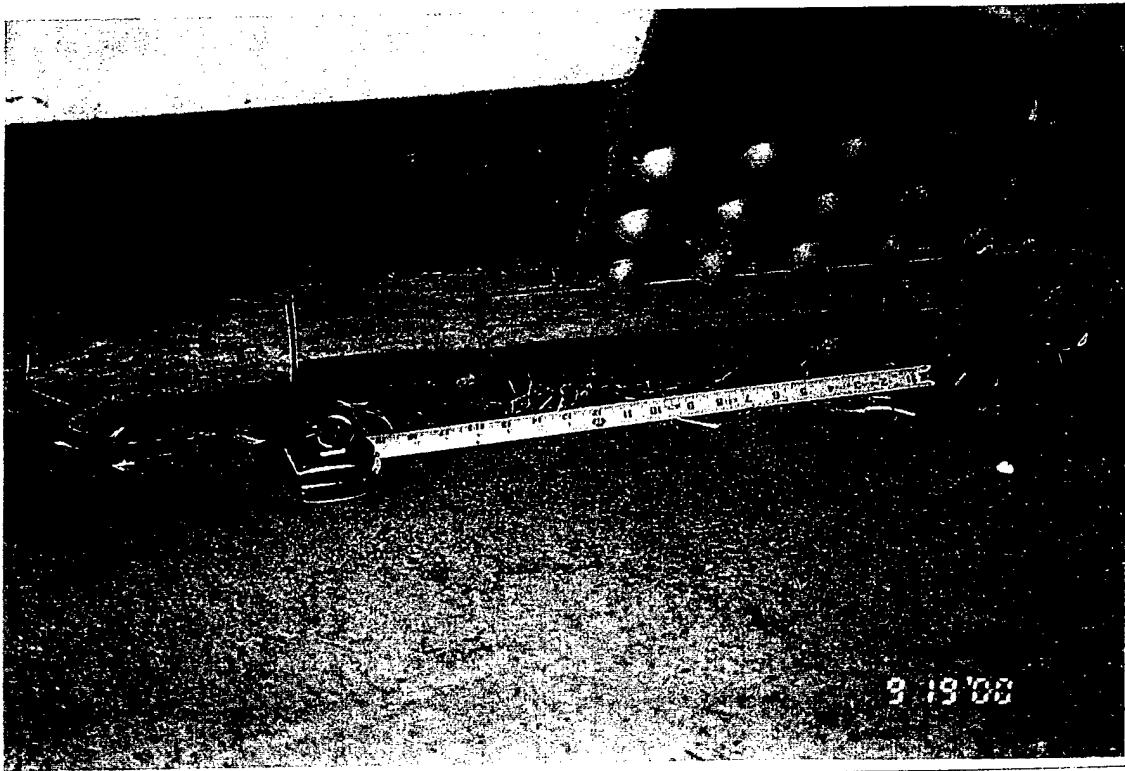

Mill
Creek
Dam

Gate 2 - 8'x18'
Bottom left side of gate at timber
bumper. Splitting at end of bumper.

9/19/00

2-3



Mill
Creek
Dam

Gate 2 - 8'x18'
Close-up, bottom left side of gate at
timber bumper. Splitting at end of
bumper, light to moderate corrosion
on bottom strut.

9/19/00

2-4

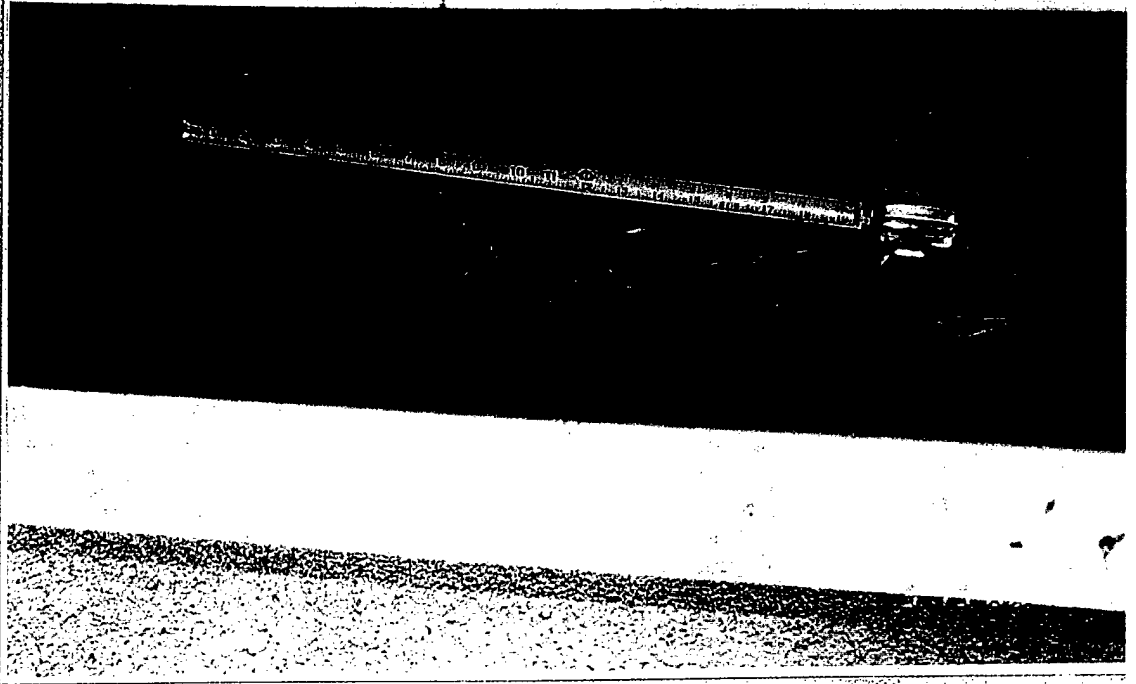

Mill
Creek
Dam
9/19/00
2-5

Gate 2 - 8'x18'
Top web of bottom horizontal girder.
Debris and clogged drain holes,
typical.

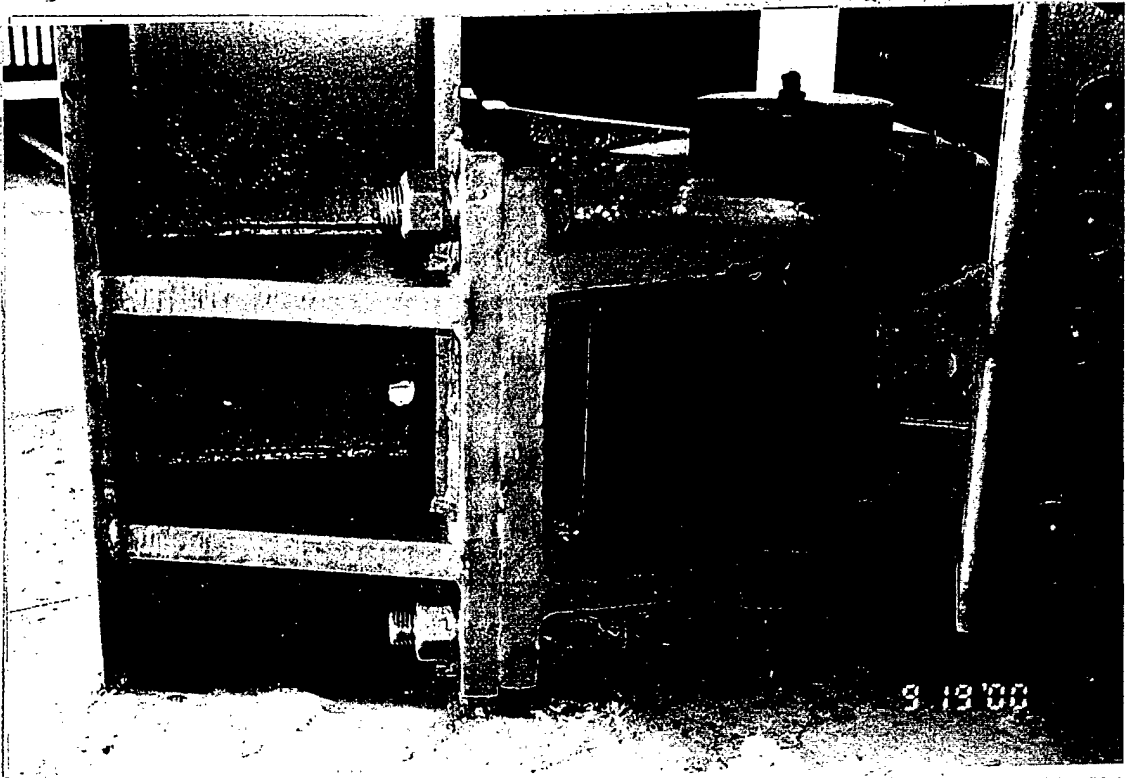

Mill
Creek
Dam
9/19/00
2-6

Gate 2 - 8'x18'
Bottom of right trunnion and trunnion
beam. Note: lubrication fitting on
trunnion pin and lubrication between
trunnion and yoke.

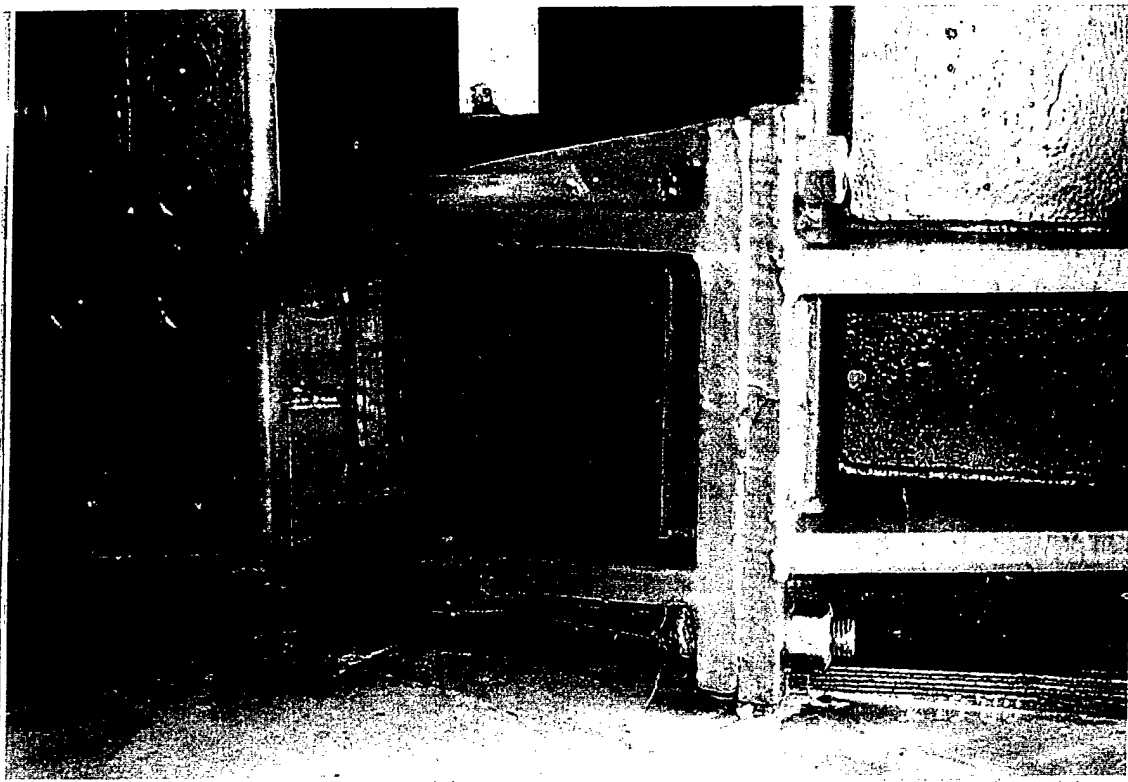

Mill
Creek
Dam
9/19/00
2-7

Gate 2 - 8'x18'
Bottom of left trunnion and trunnion beam. Note: lubrication fitting on trunnion pin and lubrication between trunnion and yoke.

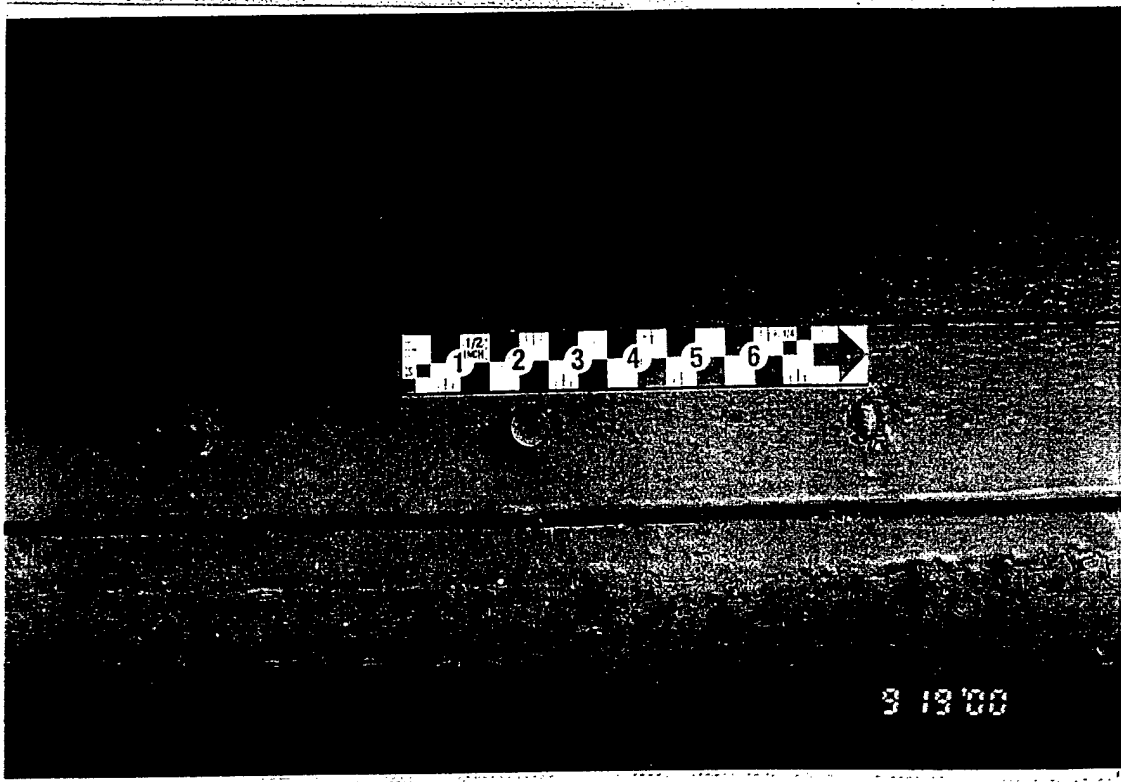

Mill
Creek
Dam
9/19/00
2-8

Gate 2 - 8'x18'
Looking upstream at skinplate and keeper bar for top seal. Note: inconsistencies in keeper bar bolts.

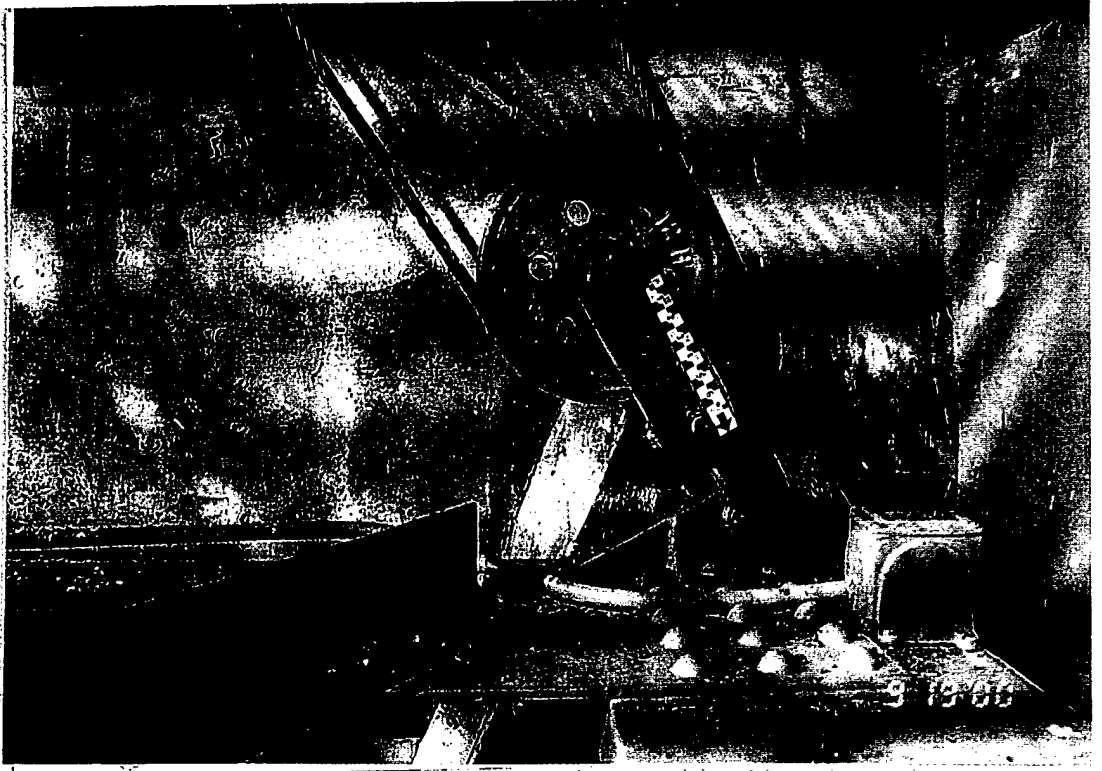

Mill
Creek
Dam

Gate 2 - 8'x18'
Right hoist reduction pulley and side
seal heater box., typical.

9/19/00

2-9

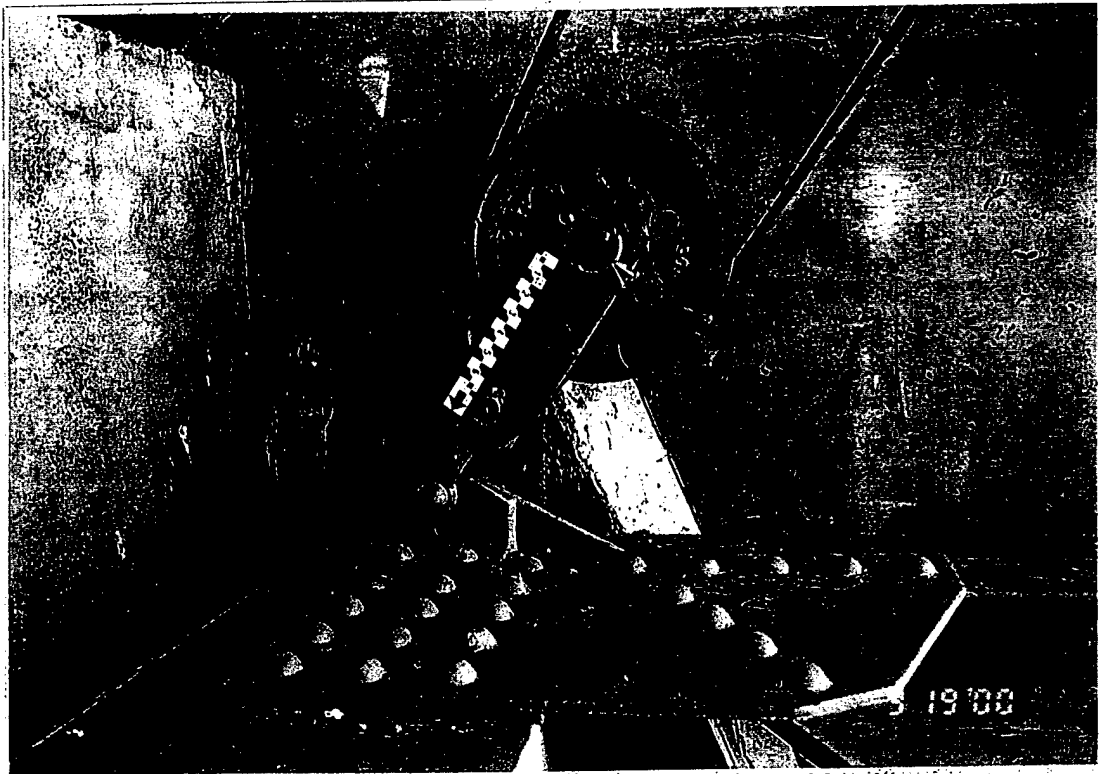

Mill
Creek
Dam

Gate 2 - 8'x18'
Left hoist reduction pulley, typical.

9/19/00

2-10

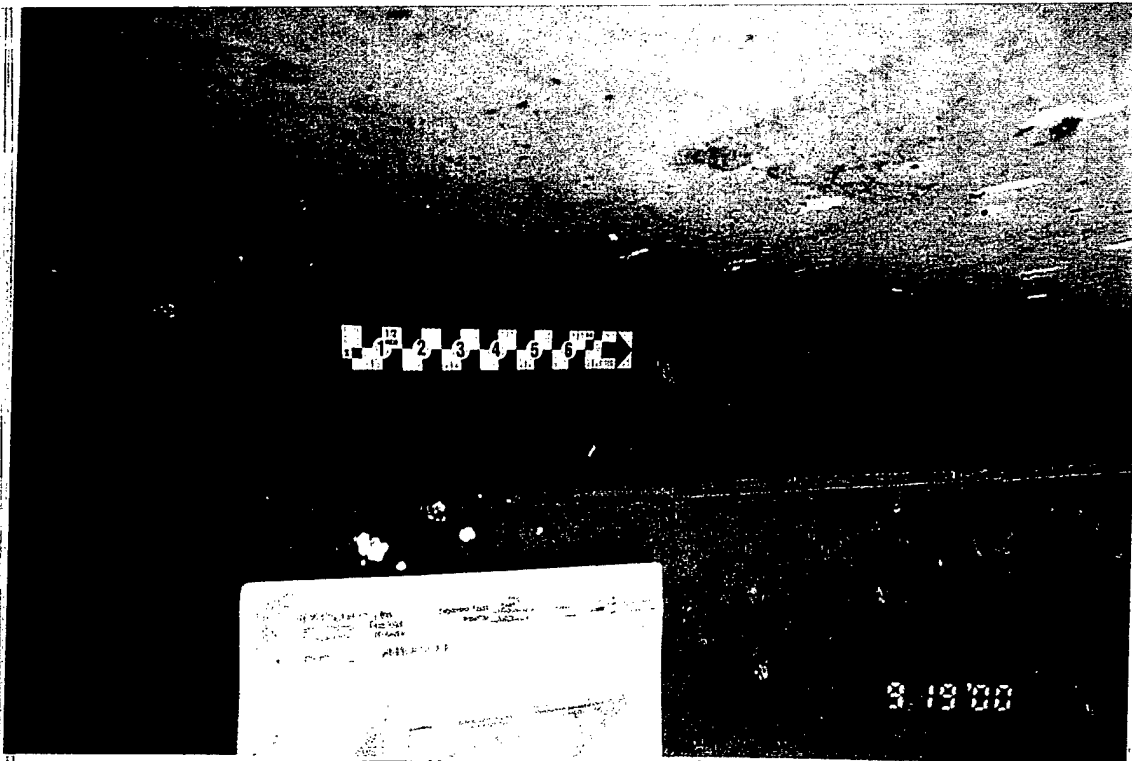

Mill
Creek
Dam

9/19/00

2-11

Gate 2 - 8'x18'
Top of top seal keeper angle, typical

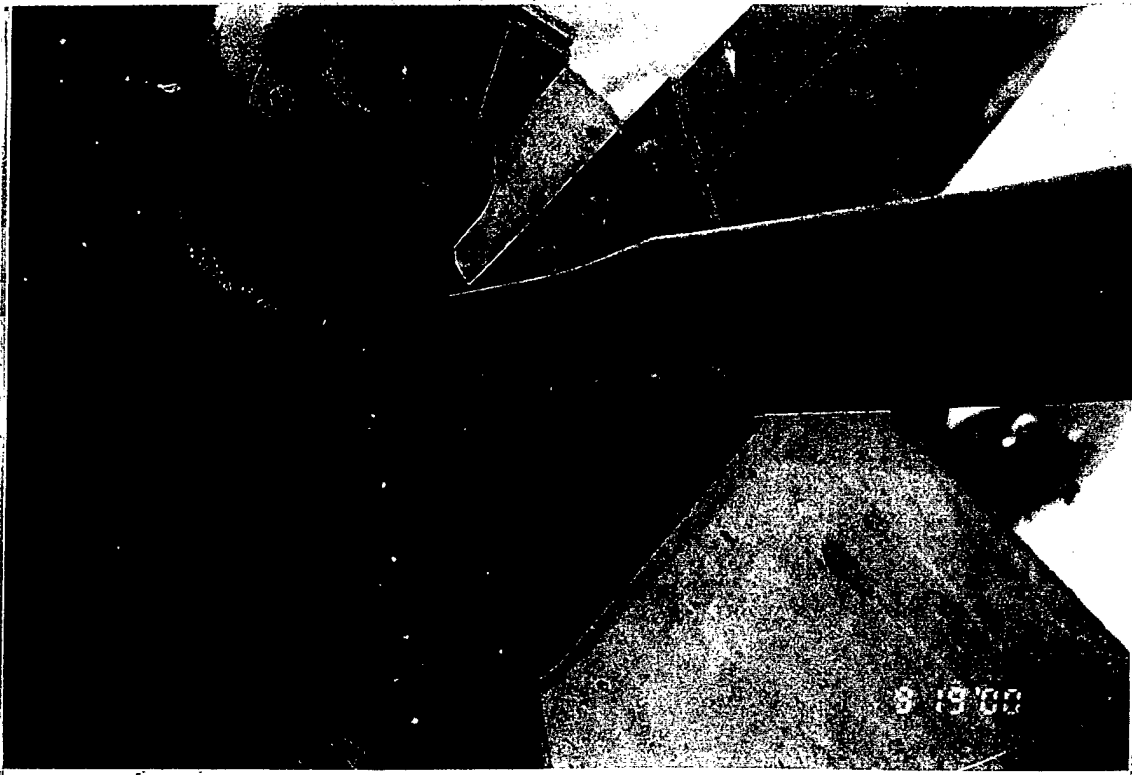

Mill
Creek
Dam

9/19/00

2-12

Gate 2 - 8'x18'
Left trunnion and bottom braces.
Note: deformation in outstanding leg
of angle brace.

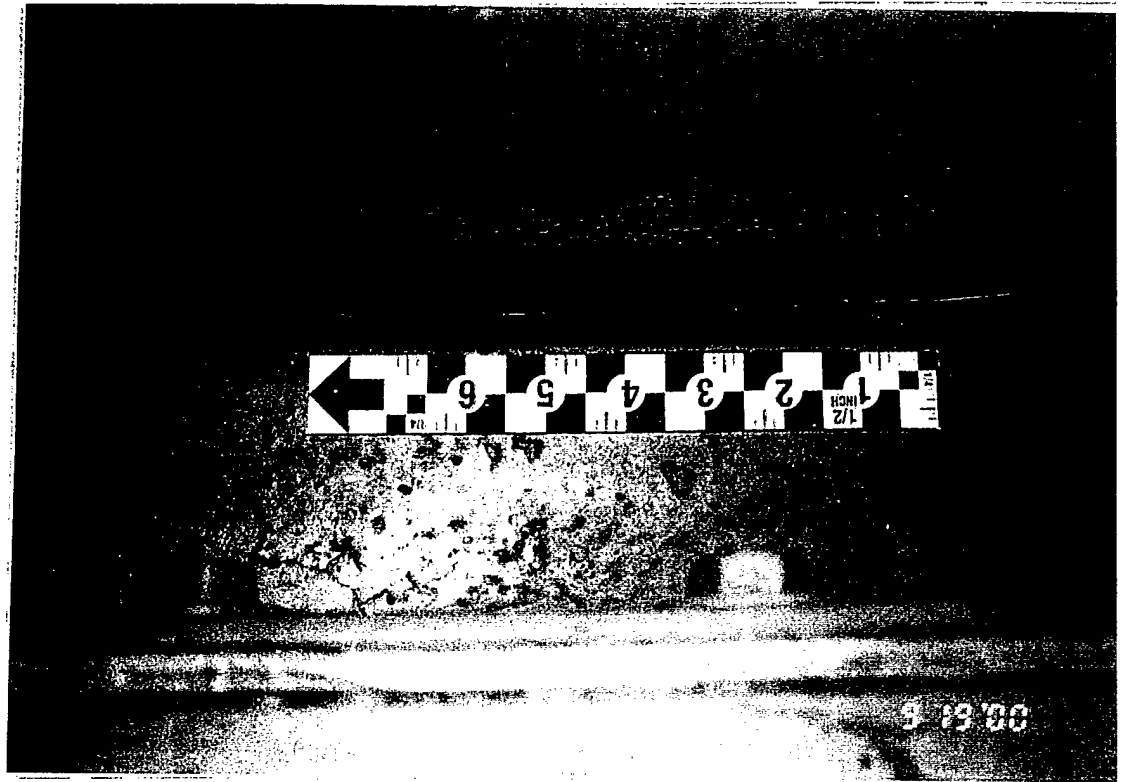

Mill
 Creek
 Dam
 9/19/00
 2-13

Gate 2 - 8'x18'
 Top of top seal and keeper angle,
 typical.

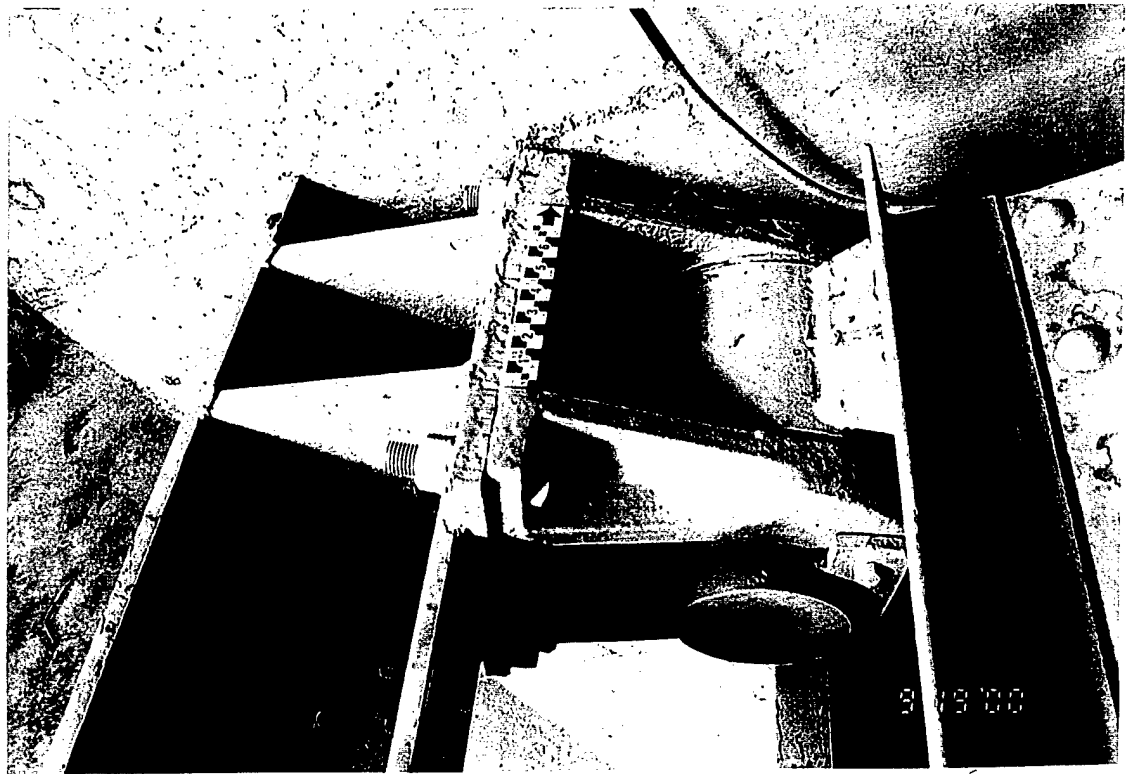

Mill
 Creek
 Dam
 9/19/00
 2-14

Gate 2 - 8'x18'
 Top of right trunnion and trunnion
 beam. Flaking paint and light
 isolated corrosion. Note: lubrication
 fitting on trunnion pin.



Mill
Creek
Dam

Gate 2 - 8'x18'
Right trunnion and side seal heater
box. Light surface corrosion.

9/19/00

2-15

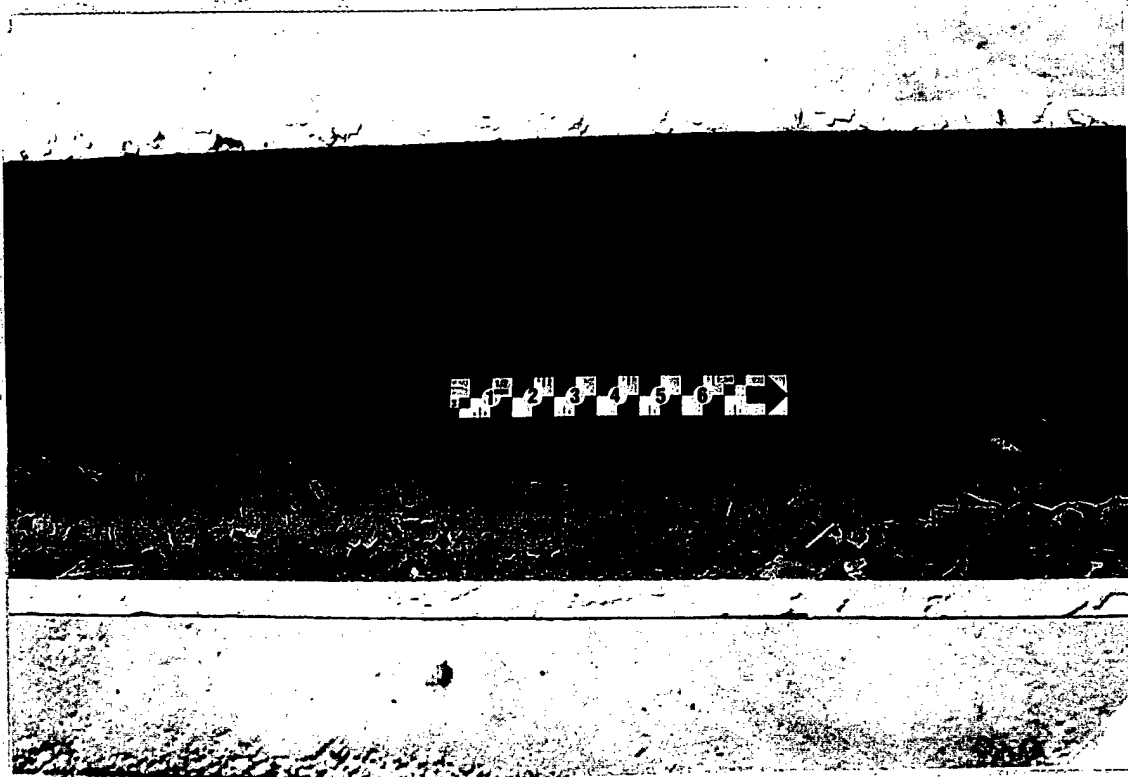

Mill
Creek
Dam

Gate 2 - 8'x18'
Top of trunnion beam. Delaminated
paint, light corrosion, debris and no
drainage

9/19/00

2-16

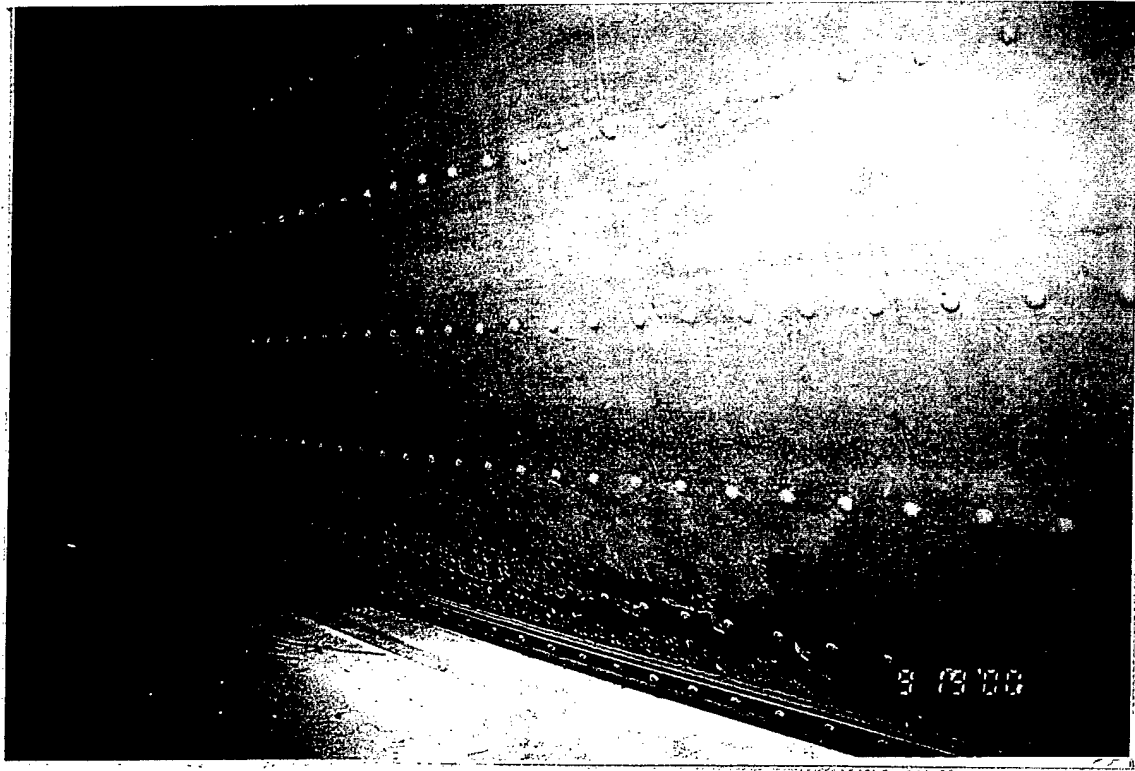

Mill
Creek
Dam

9/19/00

2-17

Gate 2 - 8'x18'
Upstream side of skin plate, typical.



Mill
Creek
Dam

9/19/00

2-18

Gate 2 - 8'x18'
Upstream side of side seal, typical.



Mill
Creek
Dam

9/19/00

2-19

Gate 2 - 8'x18'
Close-up of skin plate, typical.

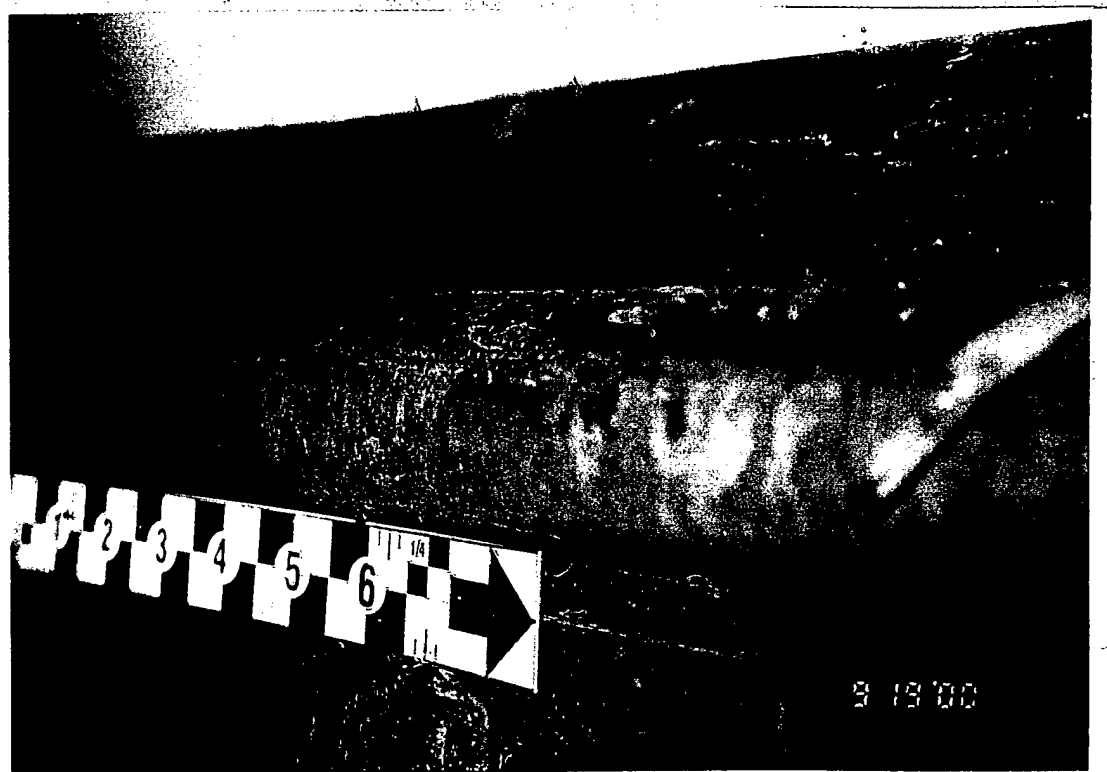

Mill
Creek
Dam

9/19/00

Gate 2 - 8'x18'
Close-up side seal, typical.



Mill
Creek
Dam

Gate 3 - 8'x18'
Gate overview.

9/19/00

3-1

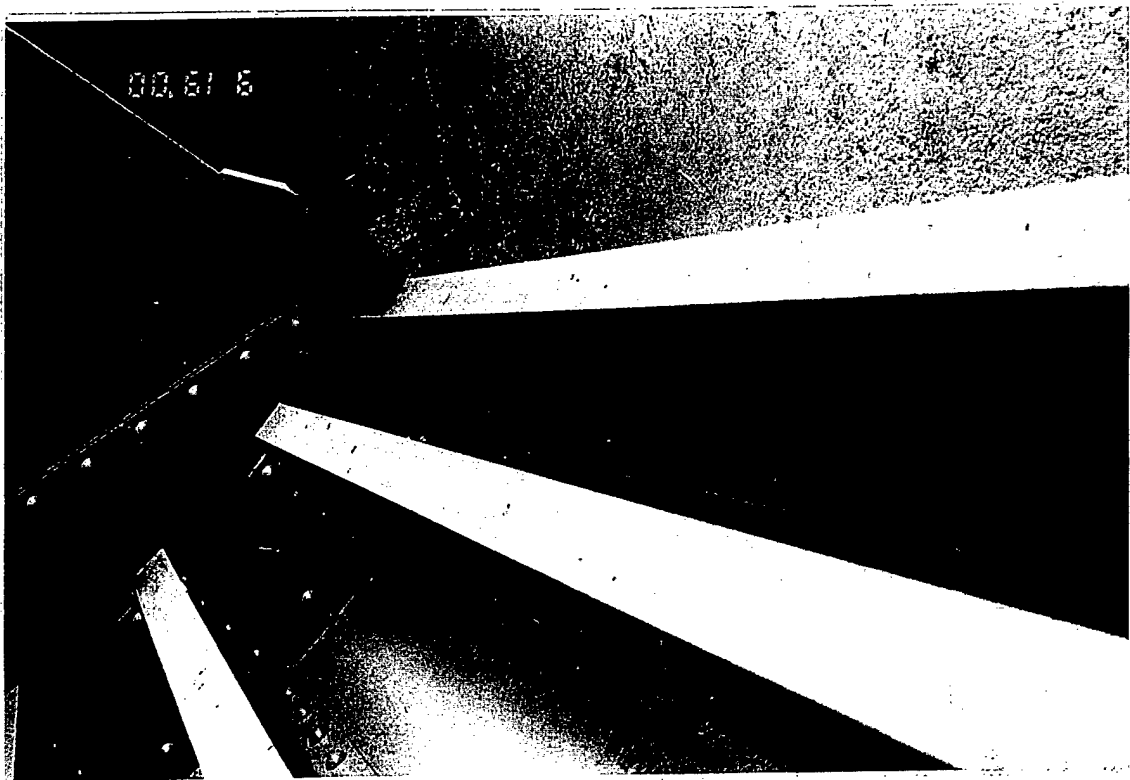

Mill
Creek
Dam

Gate 3 - 8'x18'
Bottom horizontal girder and left side
plate. Debris and clogged drain holes
on bottom girder.

9/19/00

3-2

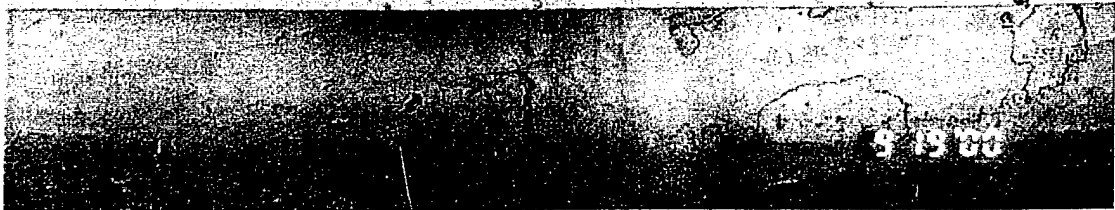

Mill
Creek
Dam

9/19/00

3-3

Gate 3 - 8'x18'
Delaminated paint on skin plate.

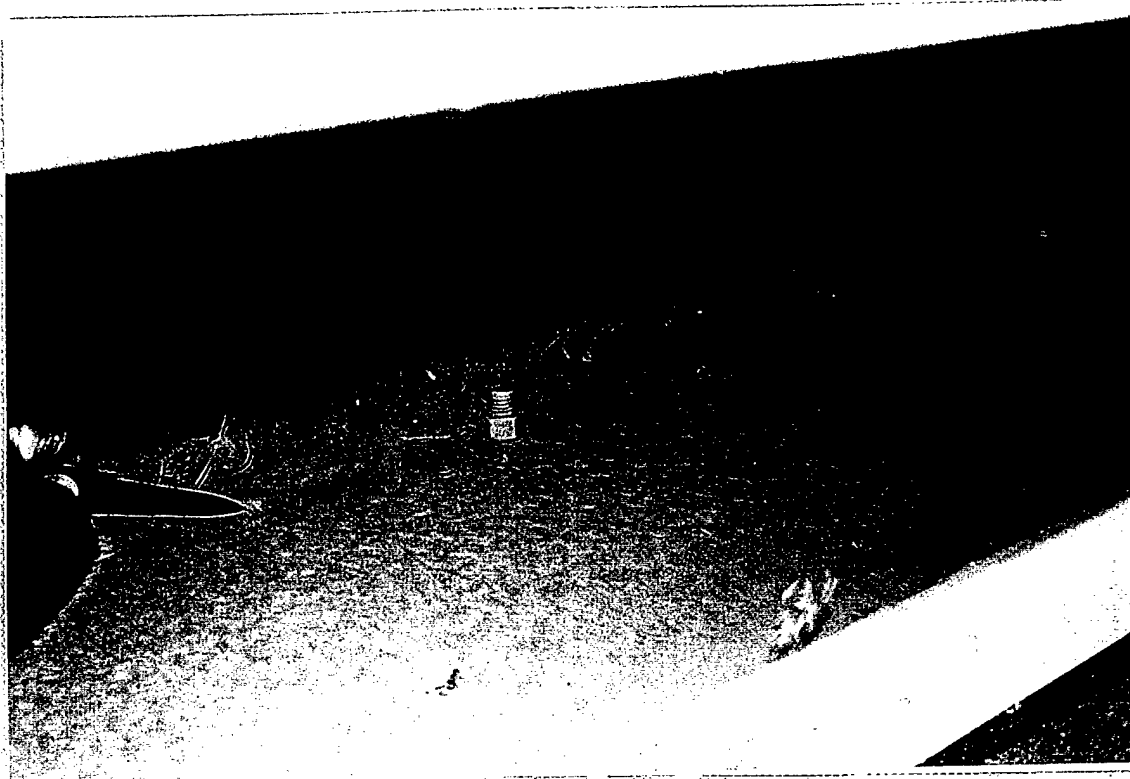

Mill
Creek
Dam

9/19/00

3-4

Gate 3 - 8'x18'
Close-up, bottom horizontal girder.
Clogged drain hole, not continued
through bottom seal timber bumper.

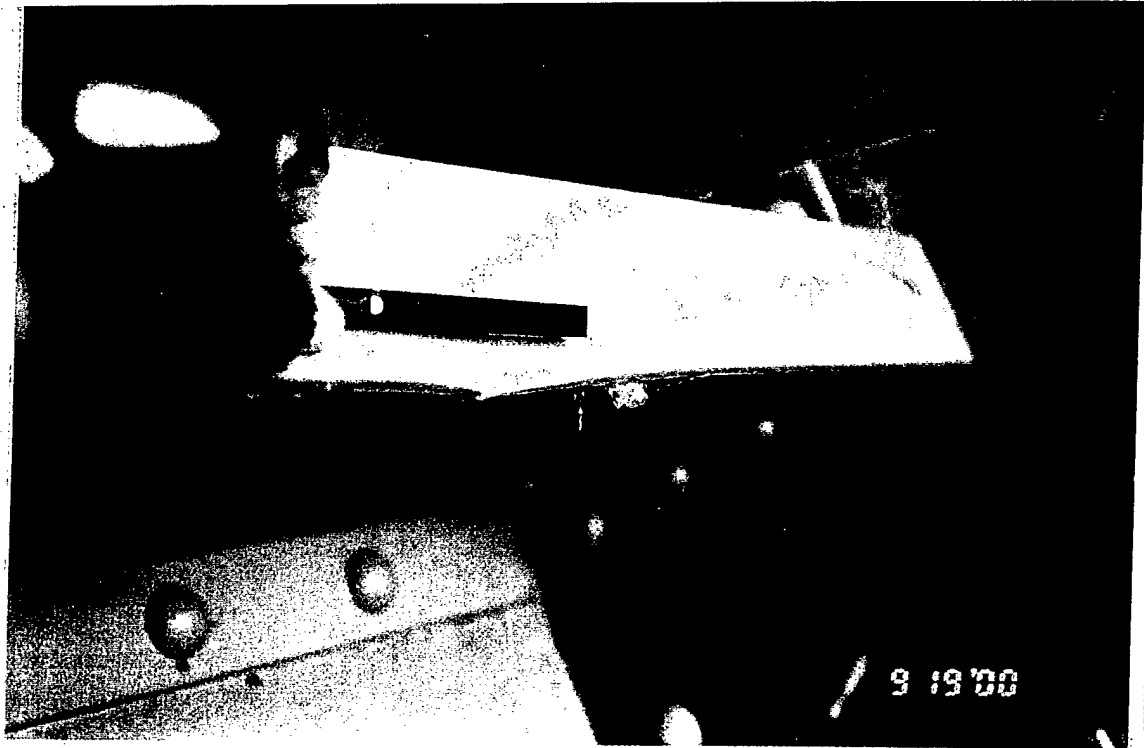

Mill
Creek
Dam

Gate 3 - 8'x18'
Small deformation in flange of
horizontal girder 3.

9/19/00

3-5

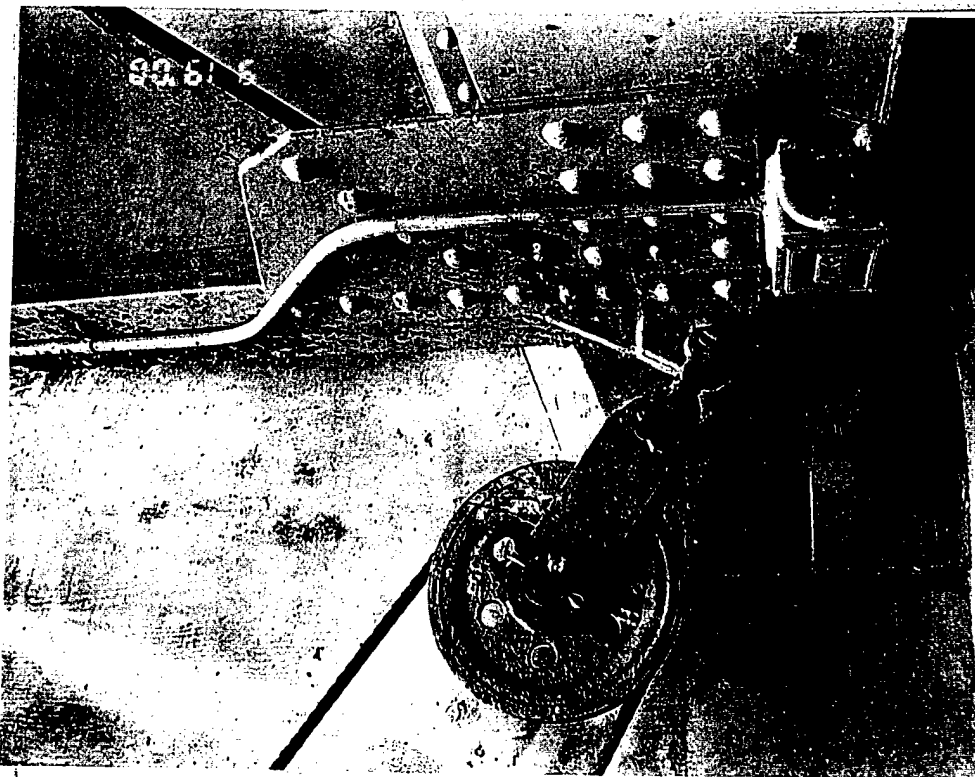

Mill
Creek
Dam

Gate 3 - 8'x18'
Left hoist reduction pulley. Note:
missing paint on pulley at previous
location of hoist connection.

9/19/00

3-6

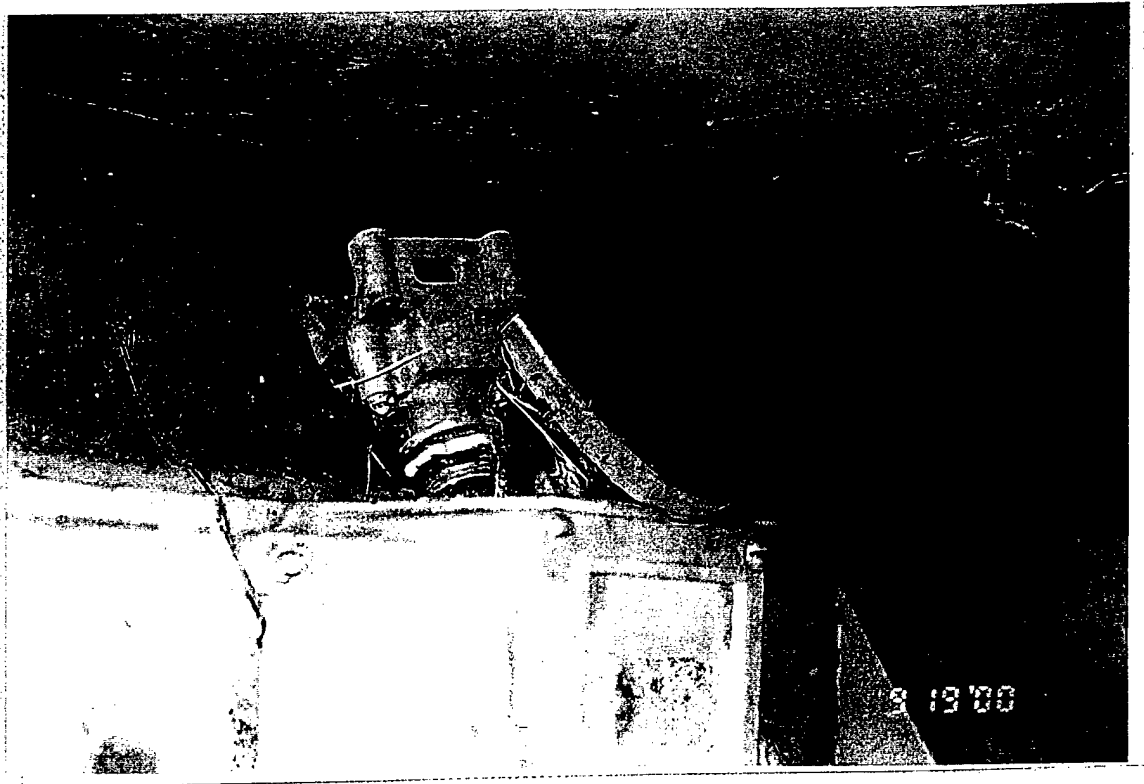

Mill
Creek
Dam
9/19/00
3-7

Gate 3 - 8'x18'
Left side seal heater junction box.
Connection appears to be dislodged
from box.

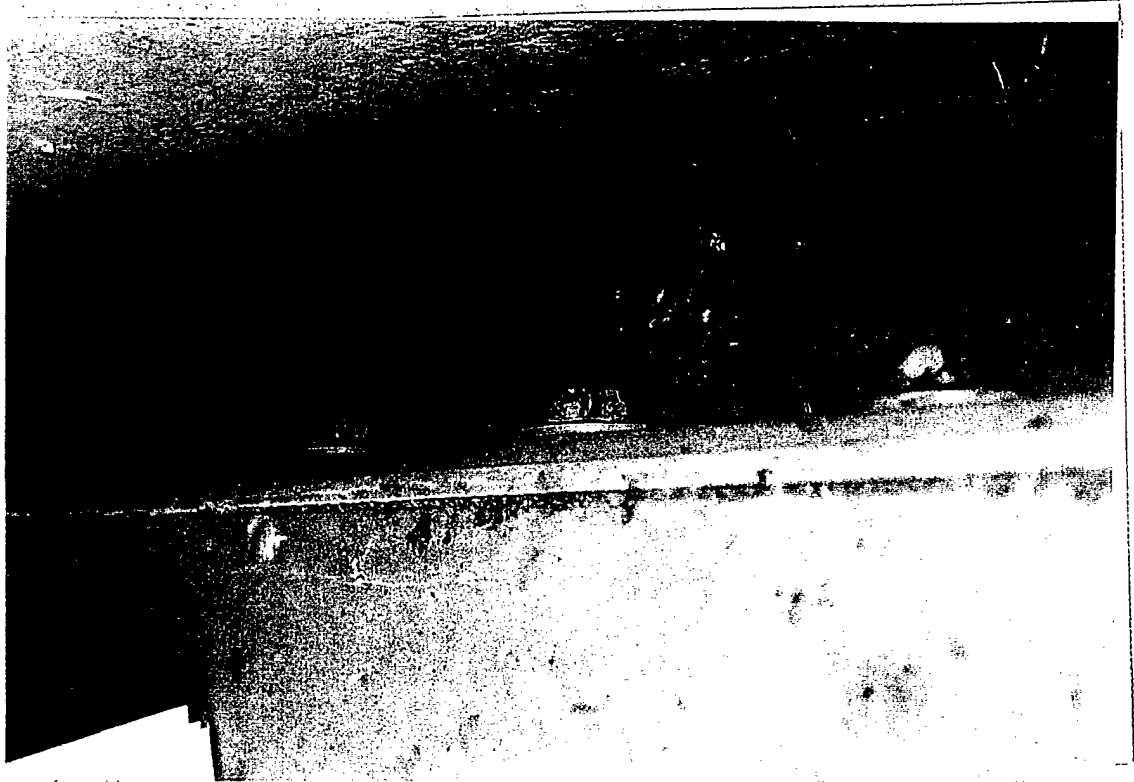

Mill
Creek
Dam
9/19/00
3-8

Gate 3 - 8'x18'
Top seal angle connection bolts,
approximately center of gate. Bolt is
loose and can be turned by hand.

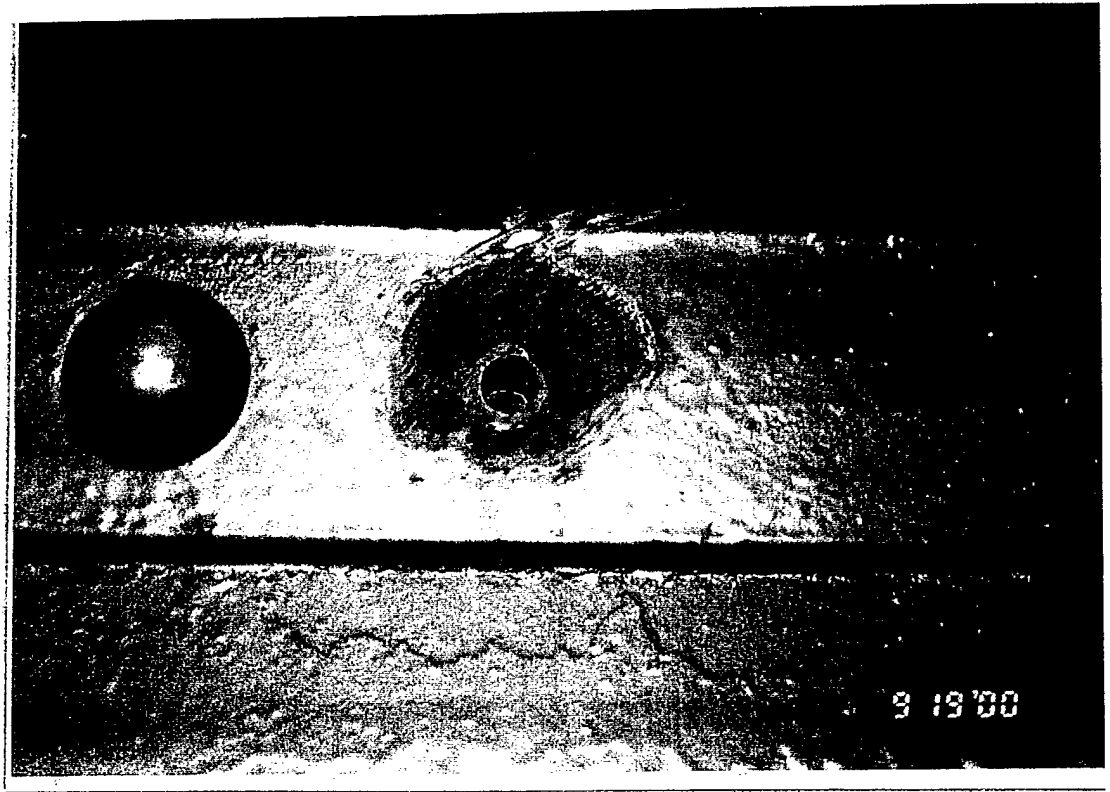

Mill
Creek
Dam
9/19/00
3-9

Gate 3 - 8'x18'
Top seal connection, missing bolt or
extra bolt hole.

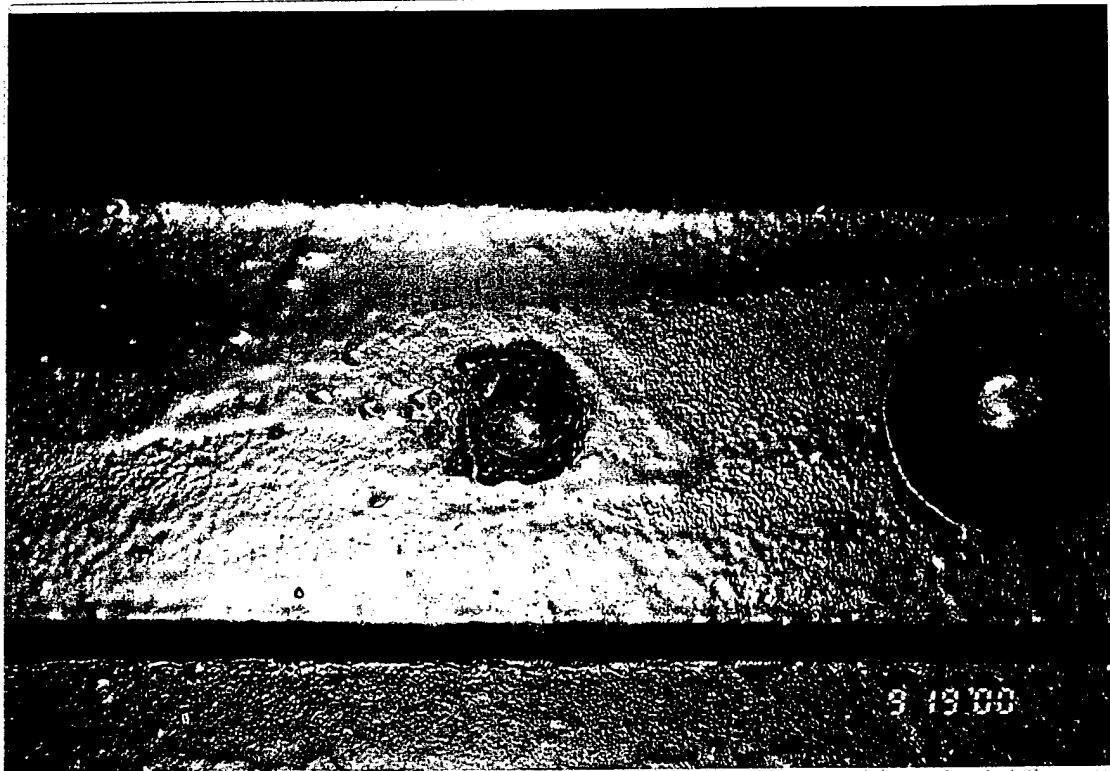

Mill
Creek
Dam
9/19/00
3-10

Gate 3 - 8'x18'
Top seal connection, unpainted bolt.
Inconsistent use of tack welds on
bolts.

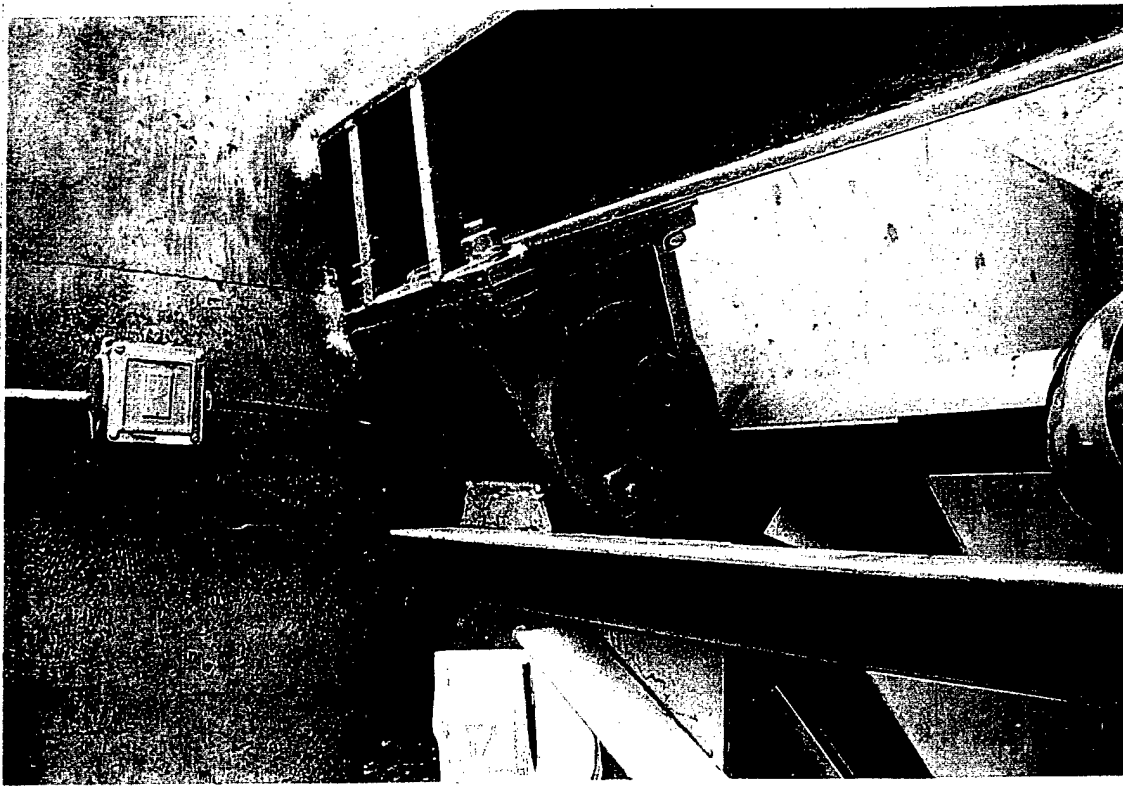

Mill
Creek
Dam

Gate 3 - 8'x18'
Left trunnion, typical.

9/19/00

3-11

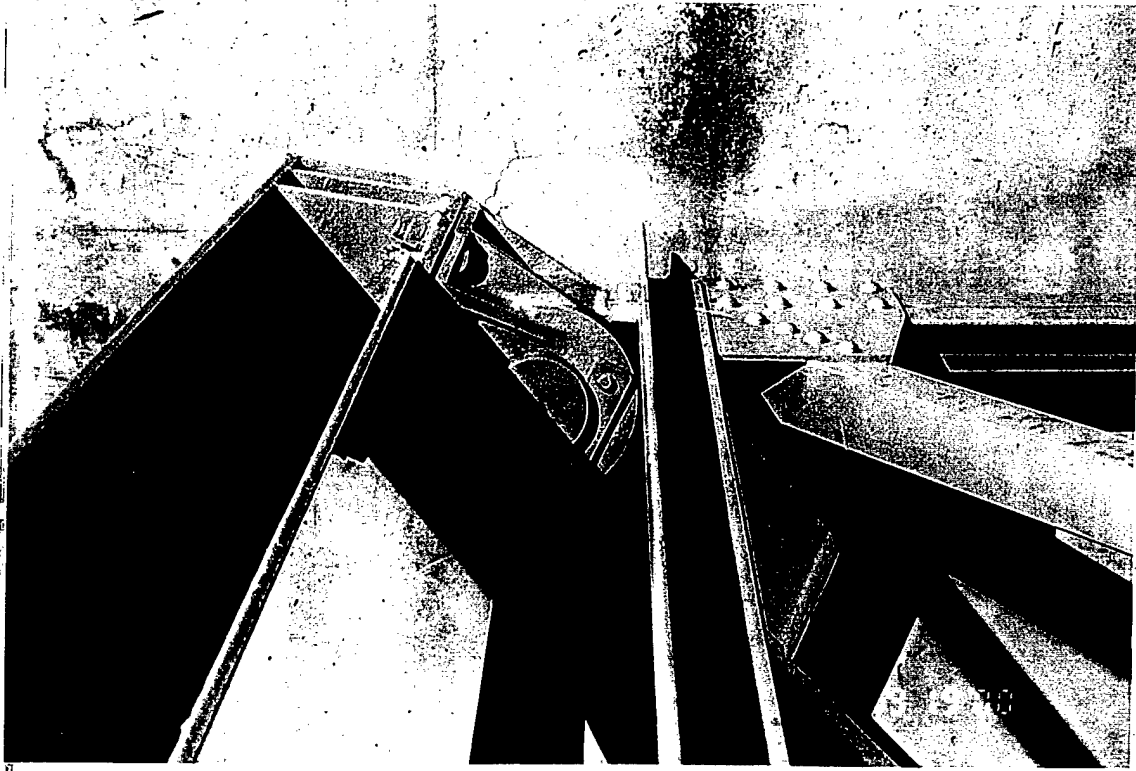

Mill
Creek
Dam

Gate 3 - 8'x18'
.Right trunnion, typical. Debris and
peeling paint in trunnion beam.

9/19/00

3-12



Mill
Creek
Dam

Gate 3 - 8'x18'
Right frame, bottom strut. Extra bolt
hole punched in angle.

9/19/00

3-13

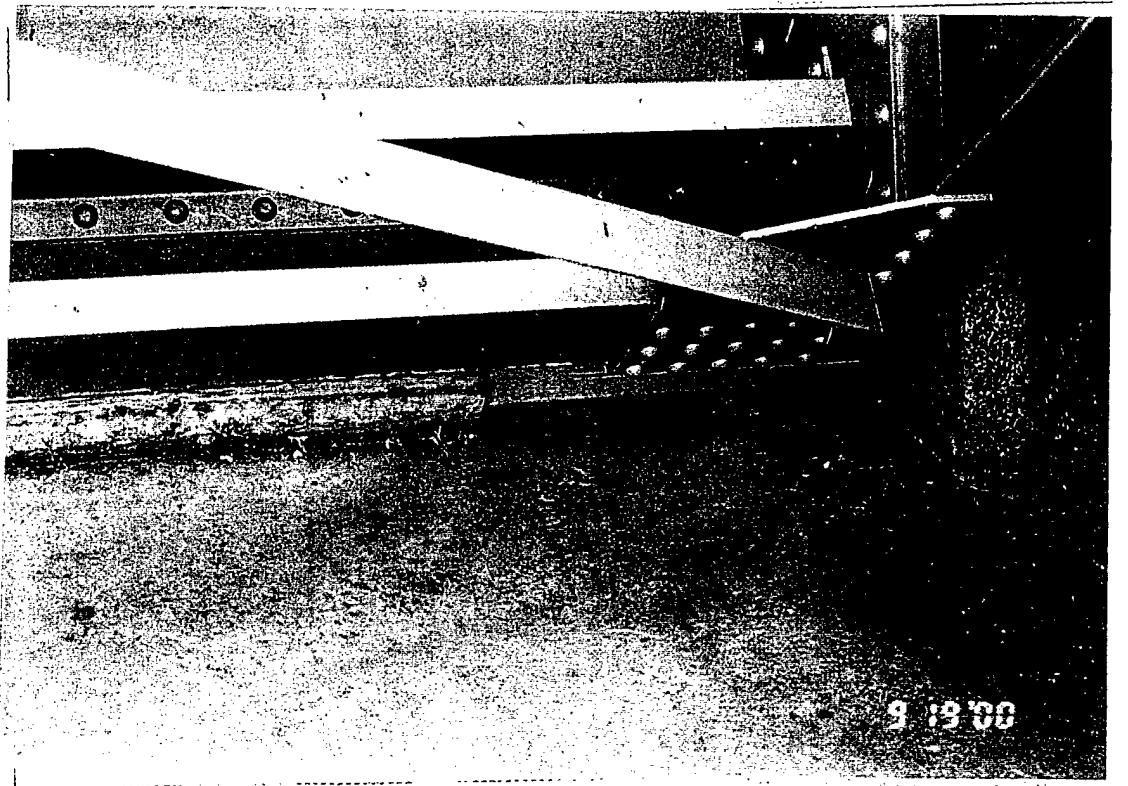

Mill
Creek
Dam

Gate 3 - 8'x18'
Left side of bottom seal timber
bumper.

9/19/00

3-14

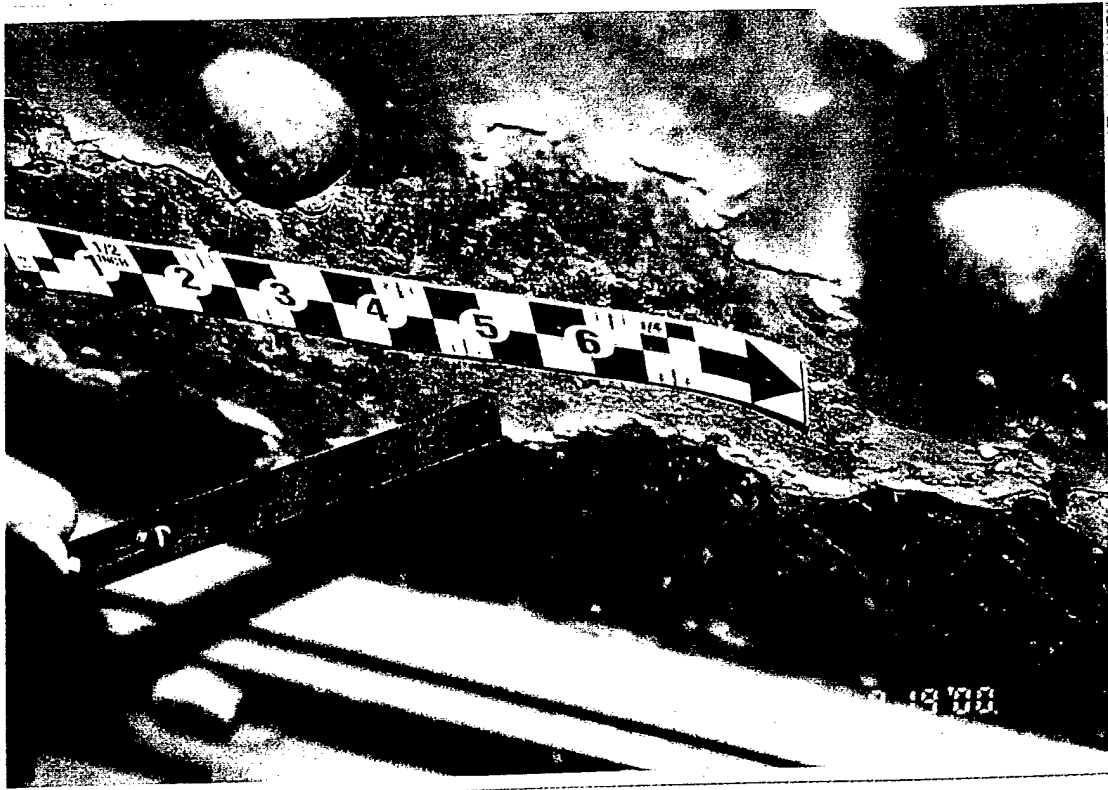

Mill
Creek
Dam

9/19/00

3-15

Gate 3 - 8'x18'
Close-up of skin plate at bottom seal.
Light to moderate corrosion.

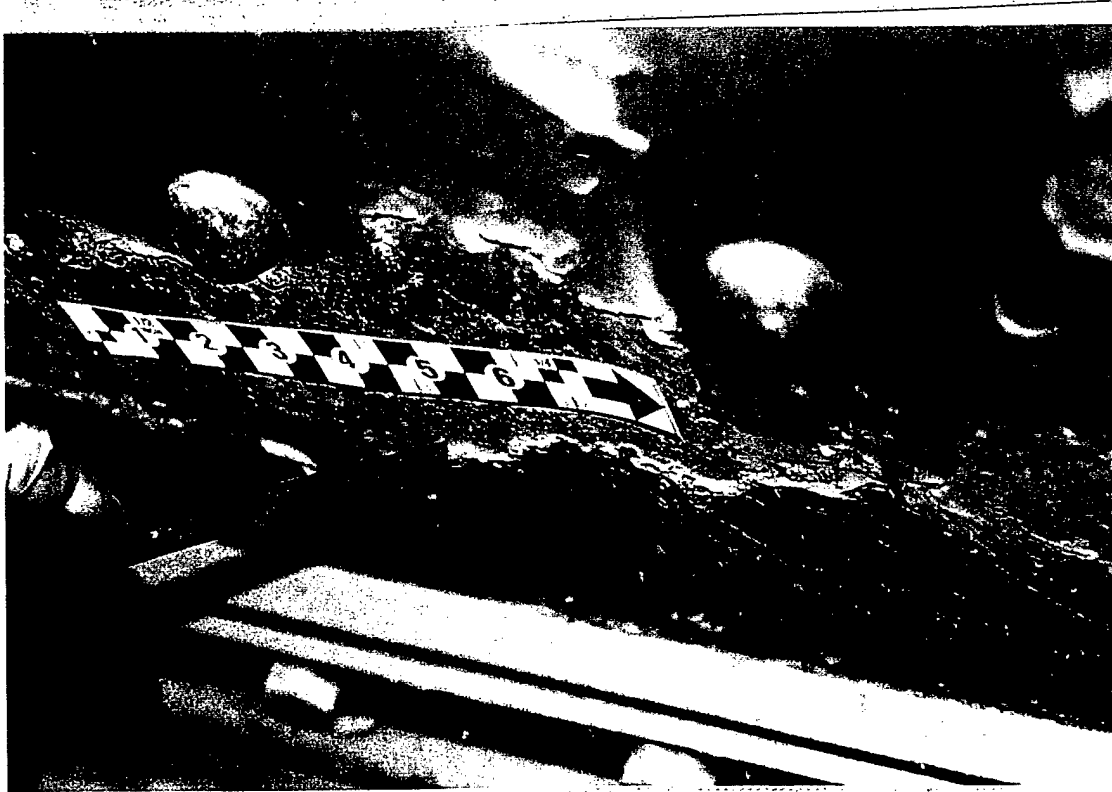

Mill
Creek
Dam

9/19/00

3-16

Gate 3 - 8'x18'
Close-up of skin plate at bottom seal.
Light to moderate corrosion.

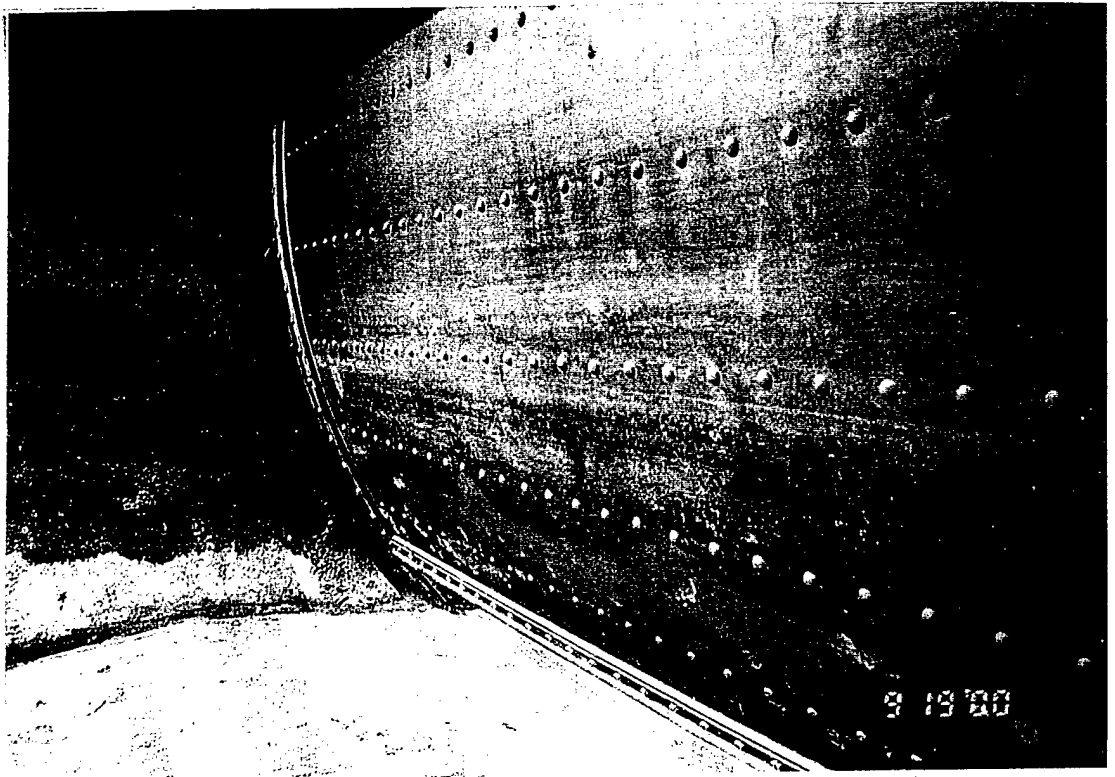

Mill
Creek
Dam

Gate 3 - 8'x18'
Skin plate, typical.

9/19/00

3-17

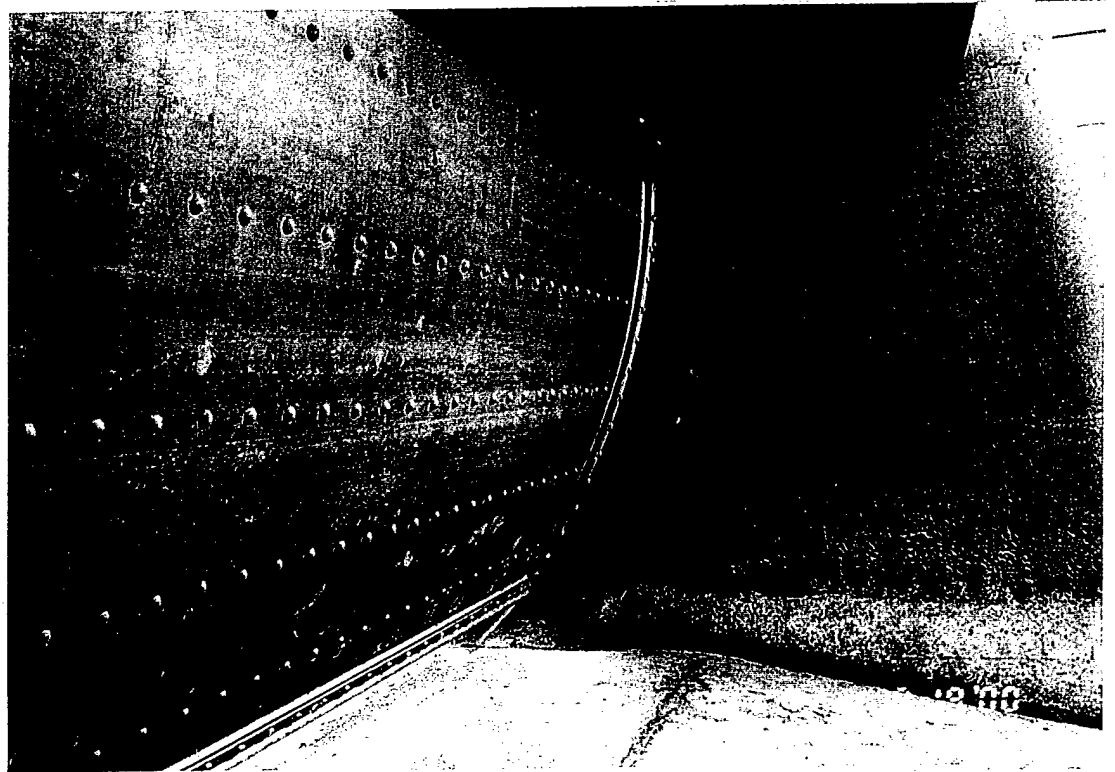

Mill
Creek
Dam

Gate 3 - 8'x18'
Skin plate, typical.

9/19/00

3-18

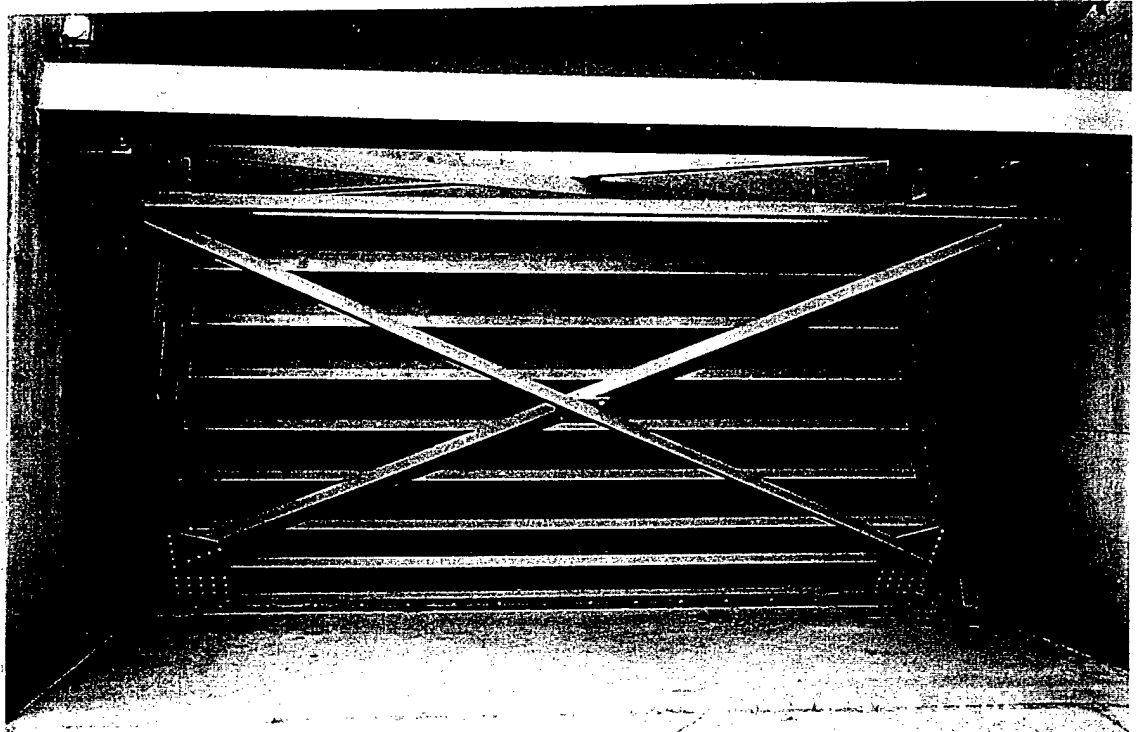

Mill
Creek
Dam

9/19/00

4-1

Gate 4 - 8'x18'
Gate overview.

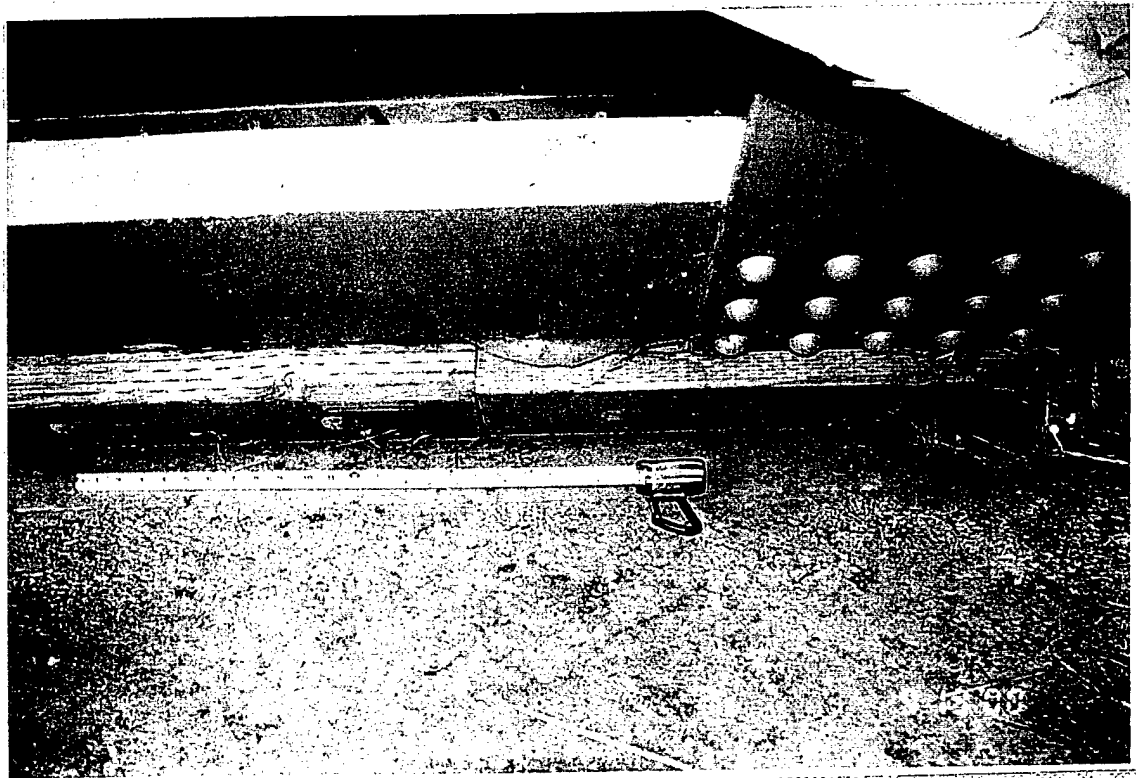

Mill
Creek
Dam

9/19/00

4-2

Gate 4 - 8'x18'
Bottom left corner of gate at bottom
seal bumper. Splintered wood
at left pier wall.

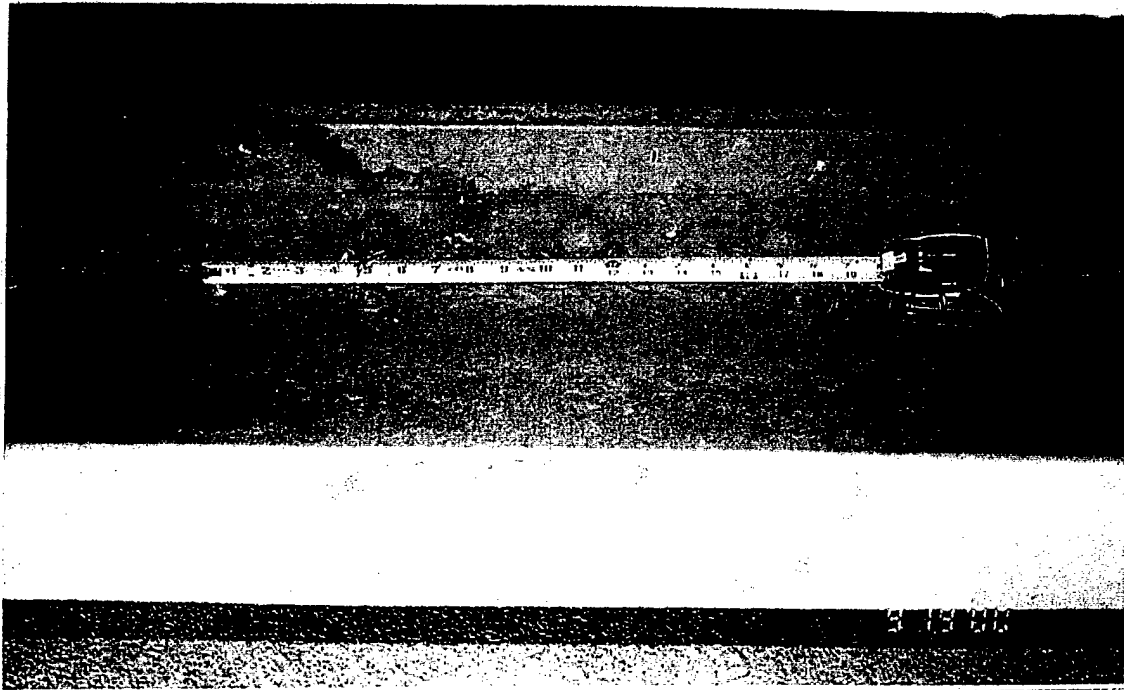

Mill
Creek
Dam

9/19/00

4-3

Gate 4 - 8'x18'
Bottom horizontal girder, typical.
Debris, clogged drain holes do not
extend through timber bumper.

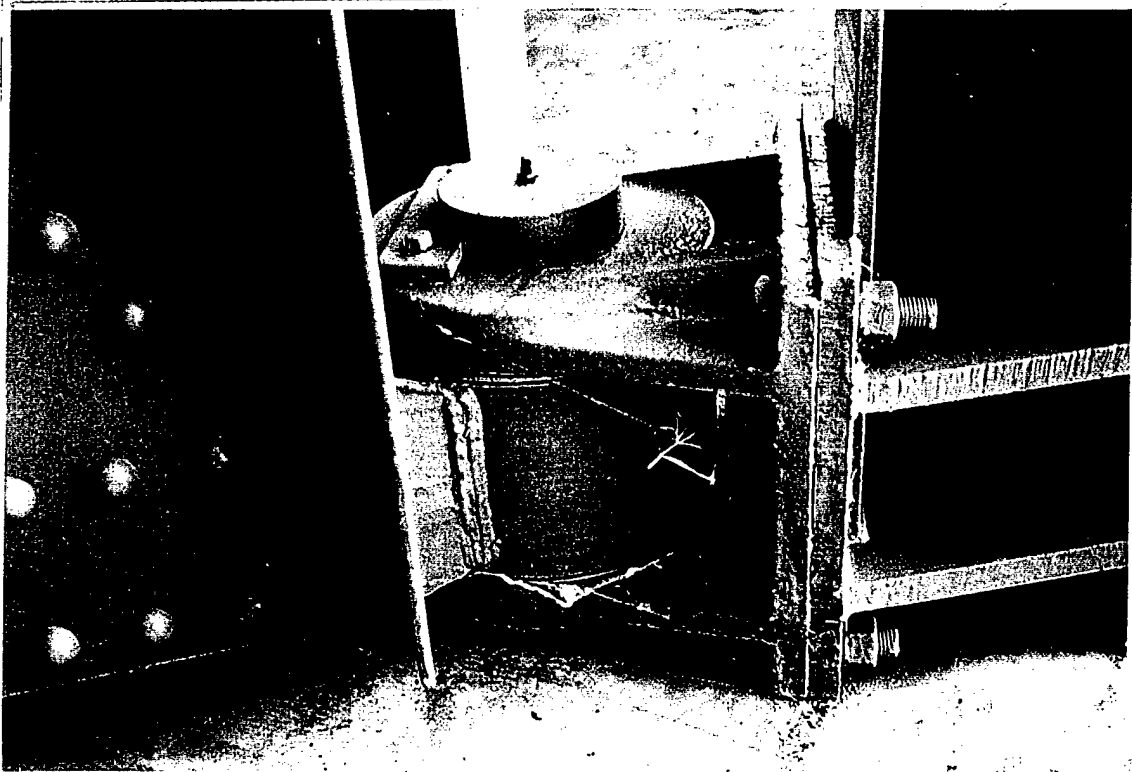

Mill
Creek
Dam

9/19/00

4-4

Gate 4 - 8'x18'
Bottom of left trunnion. Note
lubrication fitting in trunnion pin.

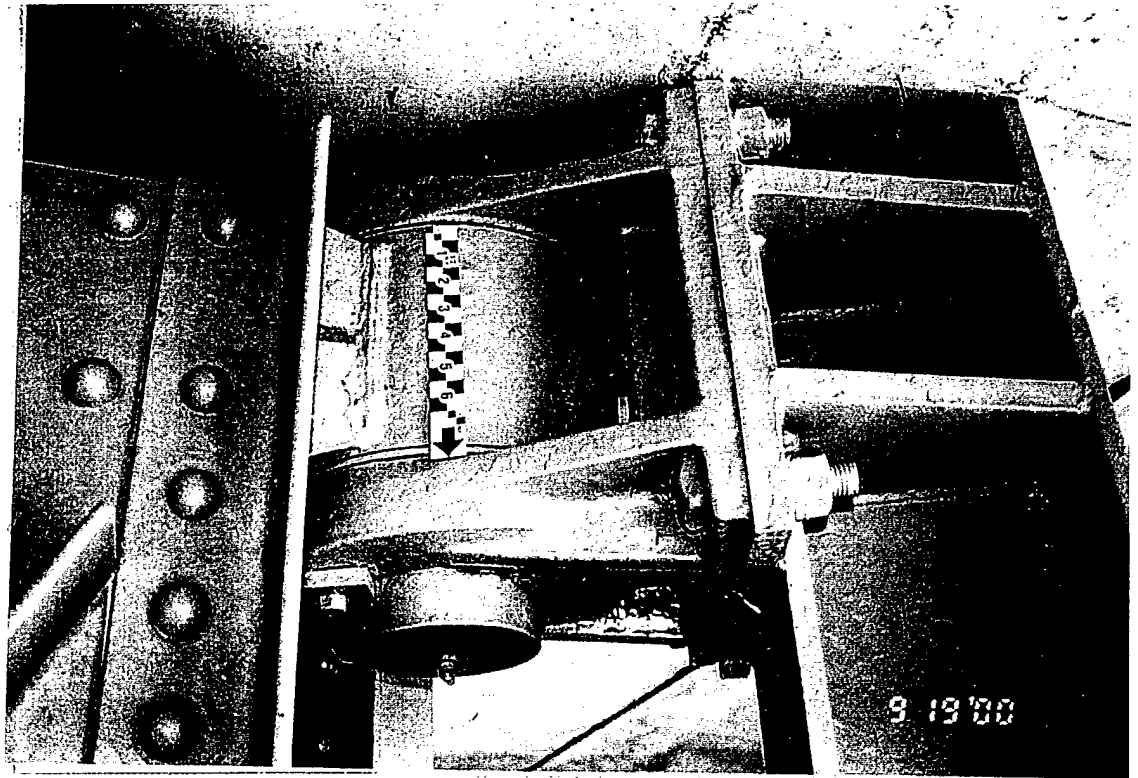

Mill
Creek
Dam

Gate 4 - 8'x18'
Top of left trunnion and trunnion
beam, typical.

9/19/00

4-5

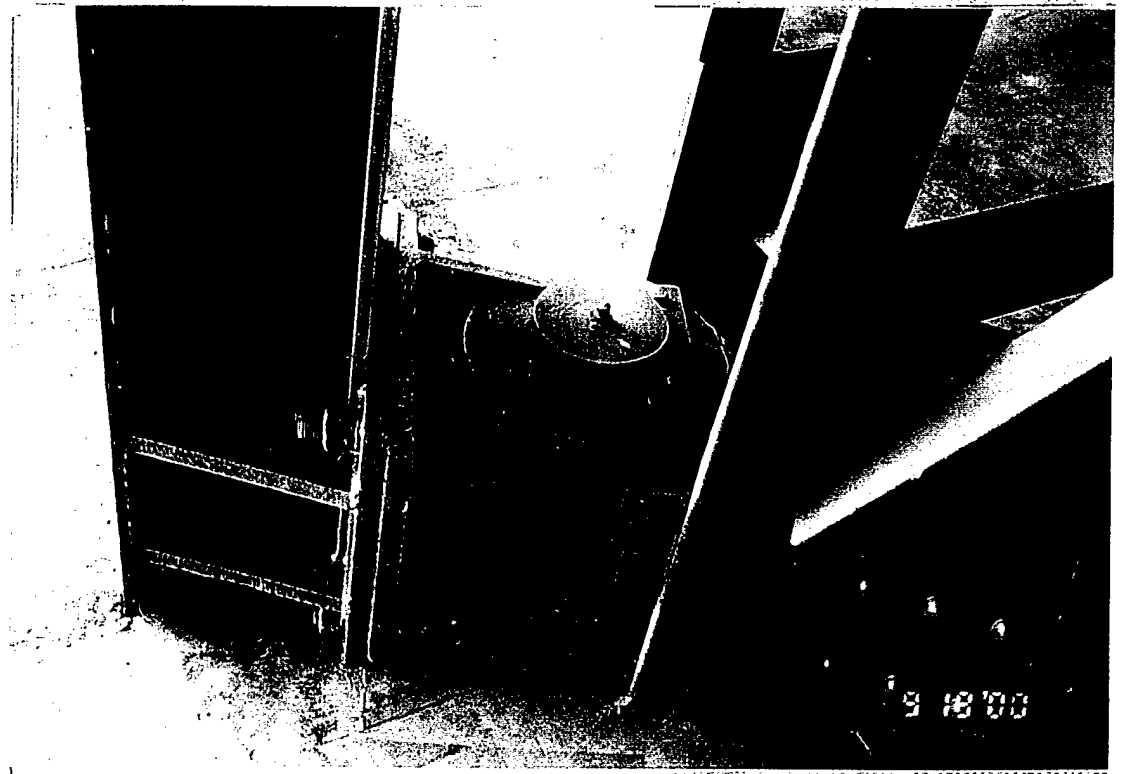

Mill
Creek
Dam

Gate 4 - 8'x18'
Bottom of right trunnion and trunnion
beam. Note lubrication fitting in
trunnion pin.

9/19/00

4-6

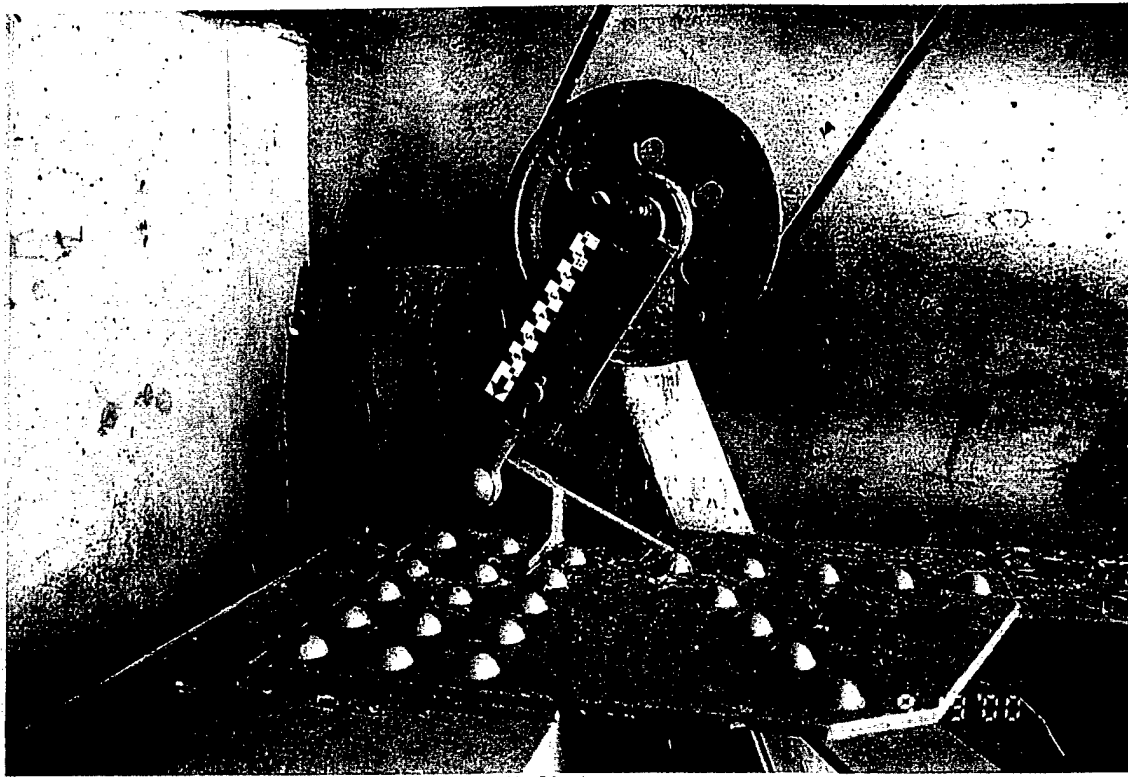

Mill
Creek
Dam
9/19/00
4-7

Gate 4 - 8'x18'
Left hoist reduction pulley. Note:
missing paint on pulley at previous
location of hoist connection.

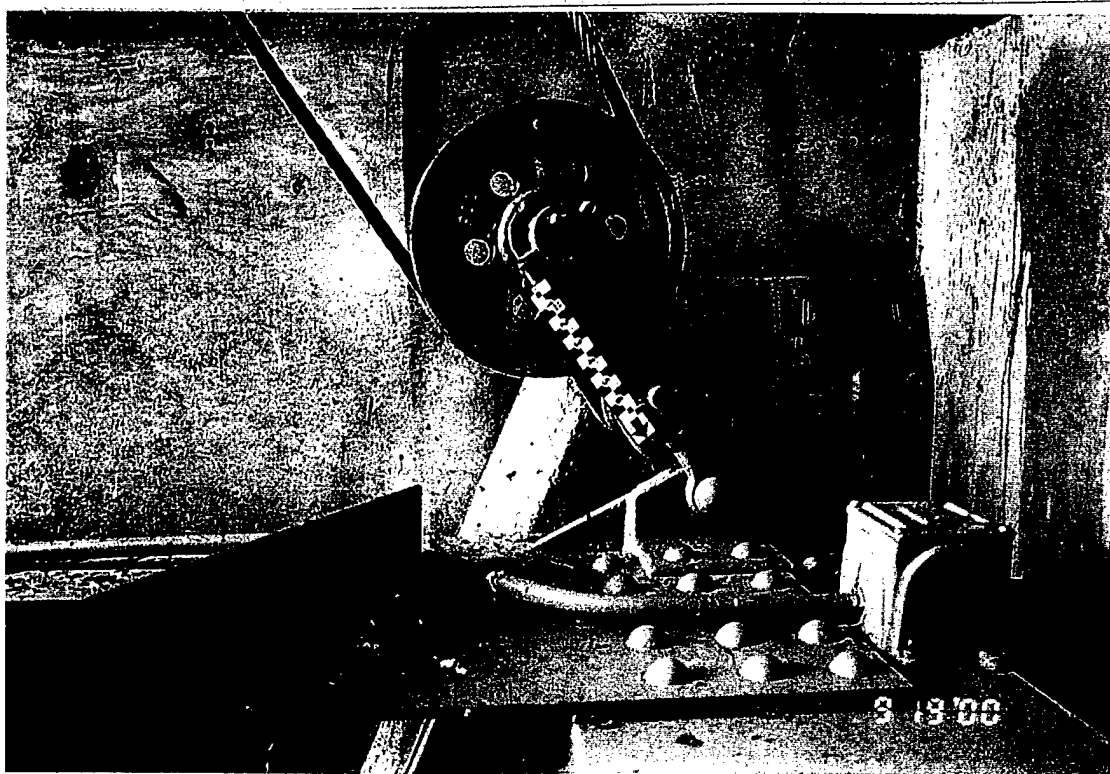

Mill
Creek
Dam
9/19/00
4-8

Gate 4 - 8'x18'
Right hoist reduction pulley. Note:
missing paint on pulley at previous
location of hoist connection.



Mill
Creek
Dam

9/19/00

4-9

Gate 4 - 8'x18'
Bottom horizontal girder, drain hole
which does not extend through timber
bumper.

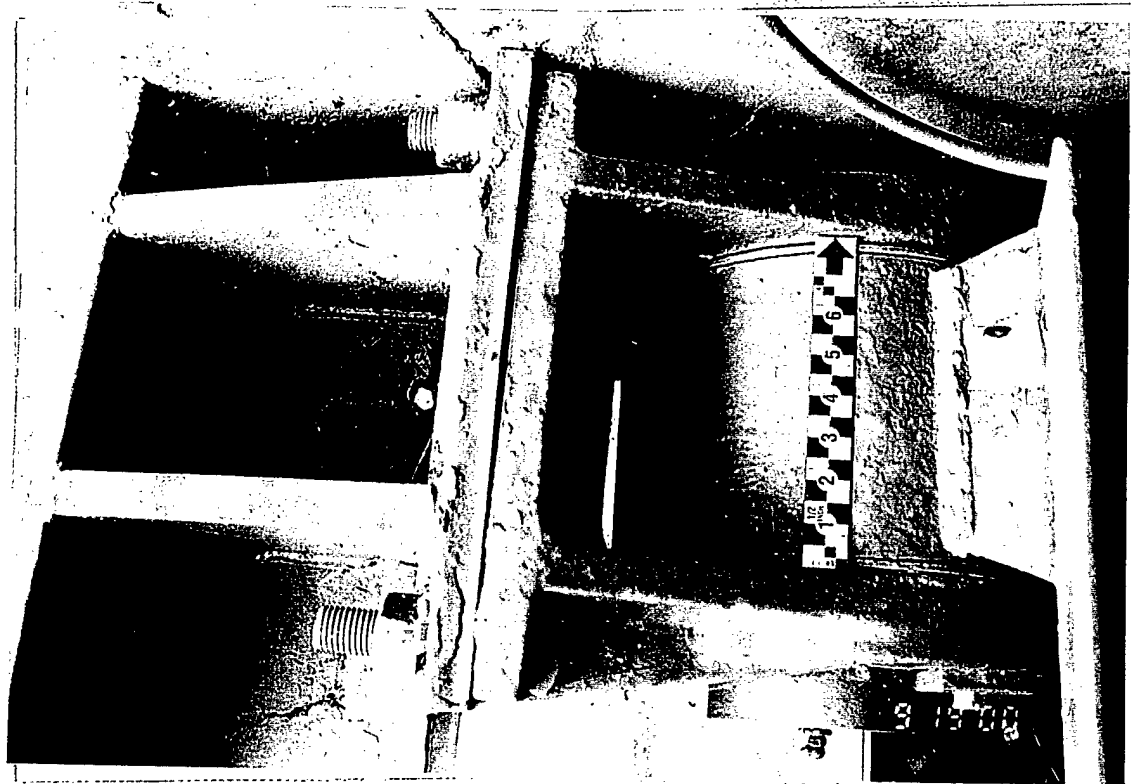

Mill
Creek
Dam

9/19/00

4-10

Gate 4 - 8'x18'
Top of right trunnion, typical.

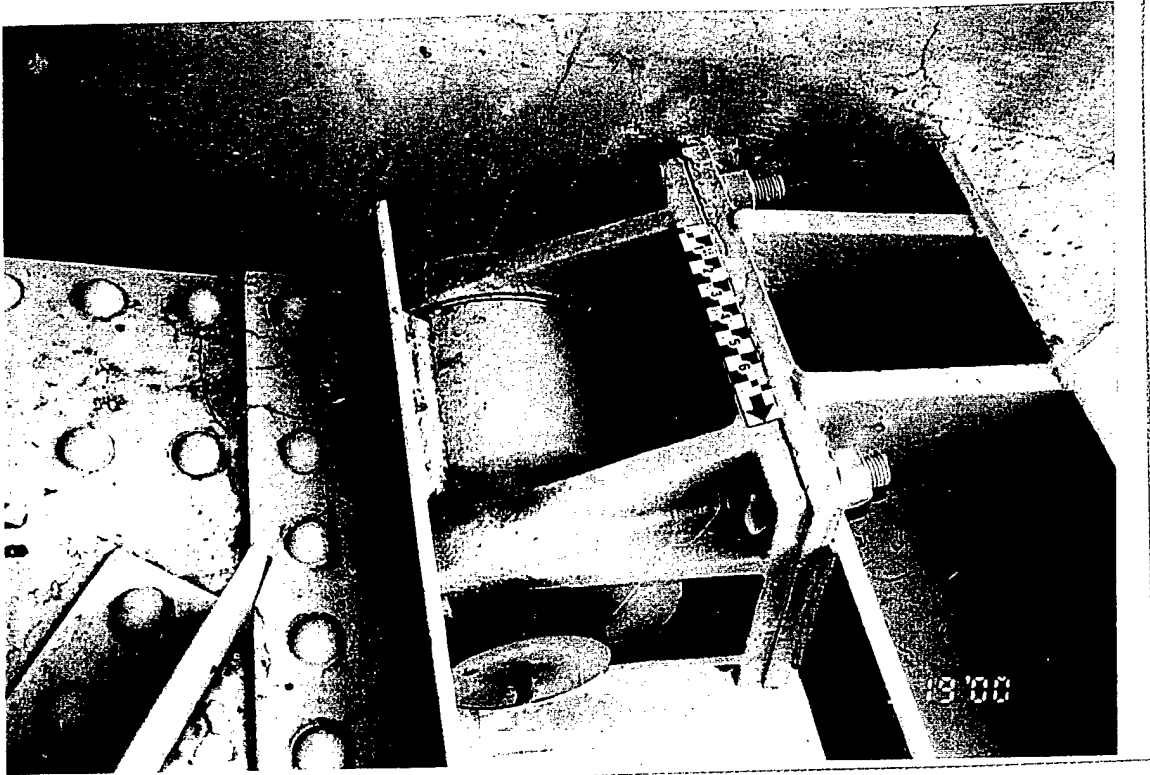

Mill
Creek
Dam Gate 4 - 8'x18'
Top of left trunnion and trunnion
beam, typical.

9/19/00

4-11

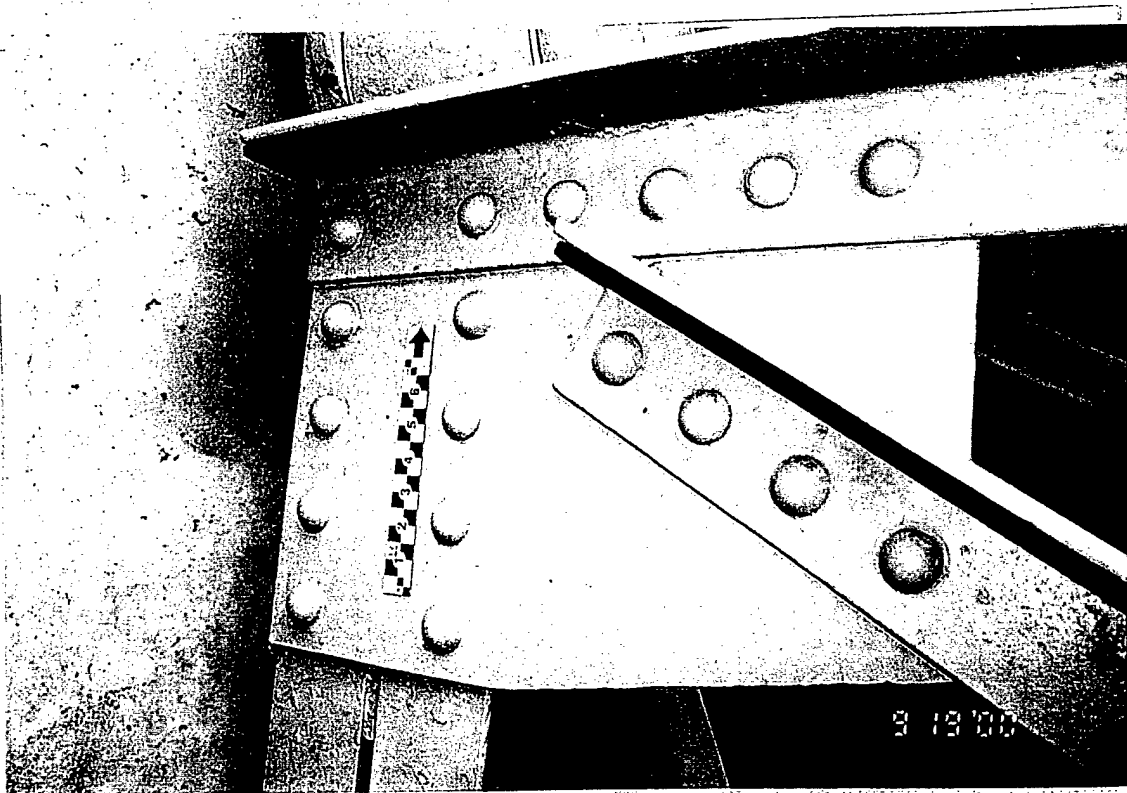

Mill
Creek
Dam Gate 4 - 8'x18'
Typical condition of riveted
connections and gusset plates.

9/19/00

4-12

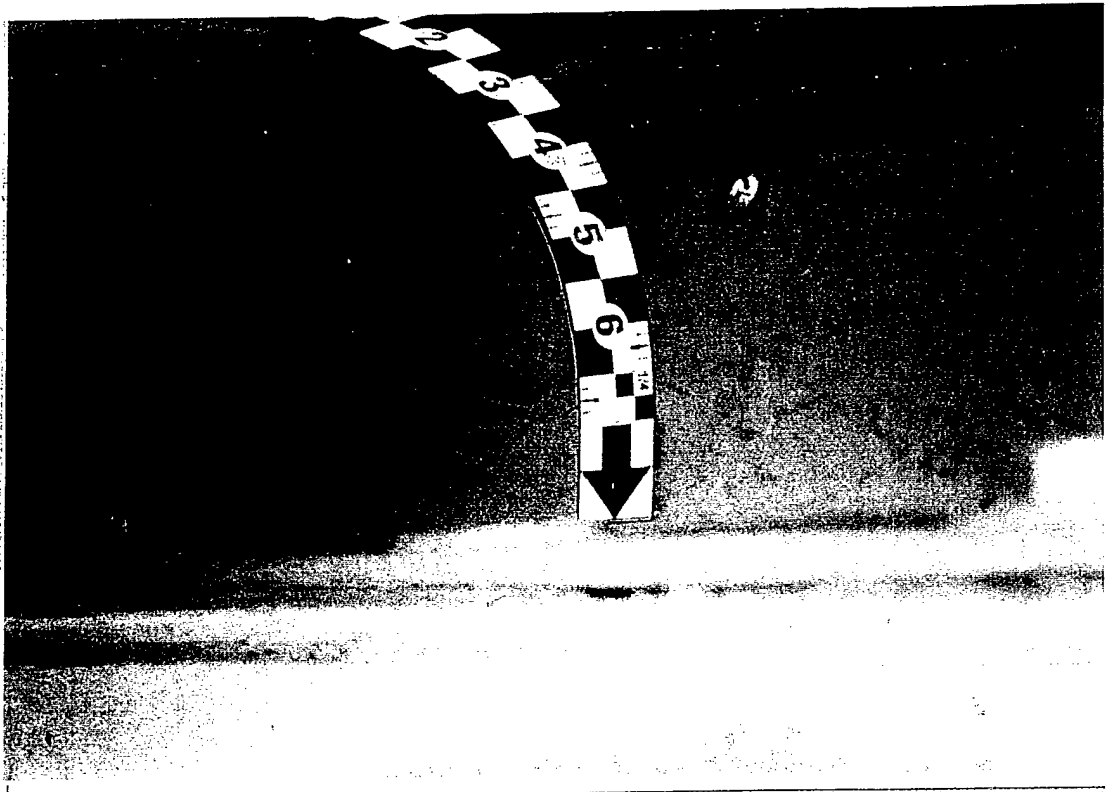

Mill
Creek
Dam

Gate 4 - 8'x18'
Missing bolt at top seal connection
angle. Typical at five locations.

9/19/00

4-13



Mill
Creek
Dam

Gate 4 - 8'x18'
Right frame. Bottom strut and side
plate angle in contact with pier wall.
Note: steel ruler between strut and
pier.

9/19/00

4-14

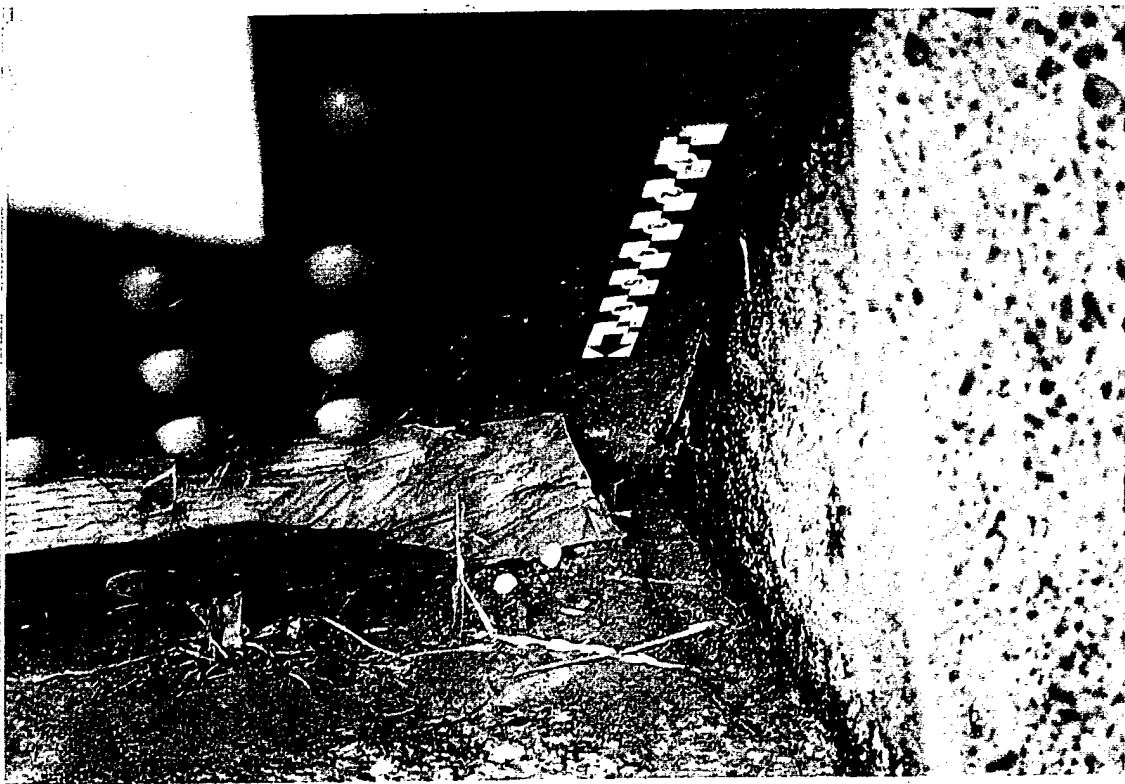

Mill
Creek
Dam

9/19/00

4-15

Gate 4 - 8'x18'

Bottom left corner, splintered timber
bumper, small deformation and light
corrosion in bottom strut.

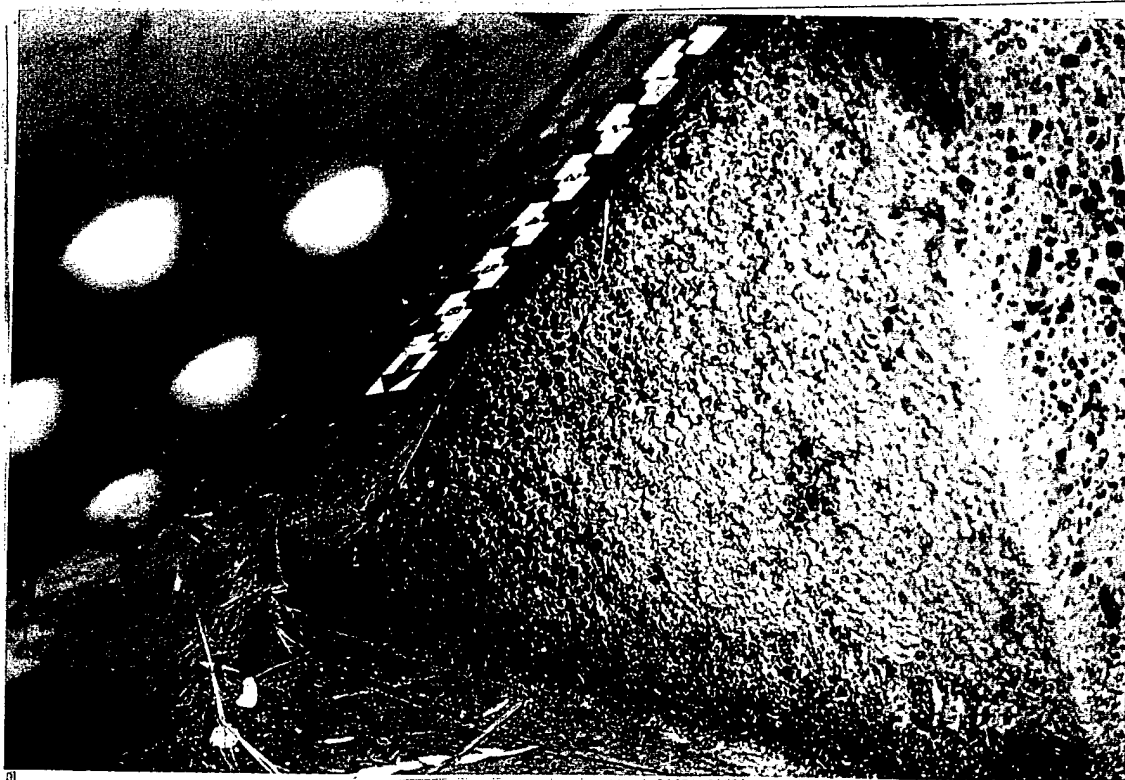

Mill
Creek
Dam

9/19/00

4-16

Gate 4 - 8'x18'

Bottom left corner, splintered timber
bumper, small deformation and light
corrosion in bottom strut.

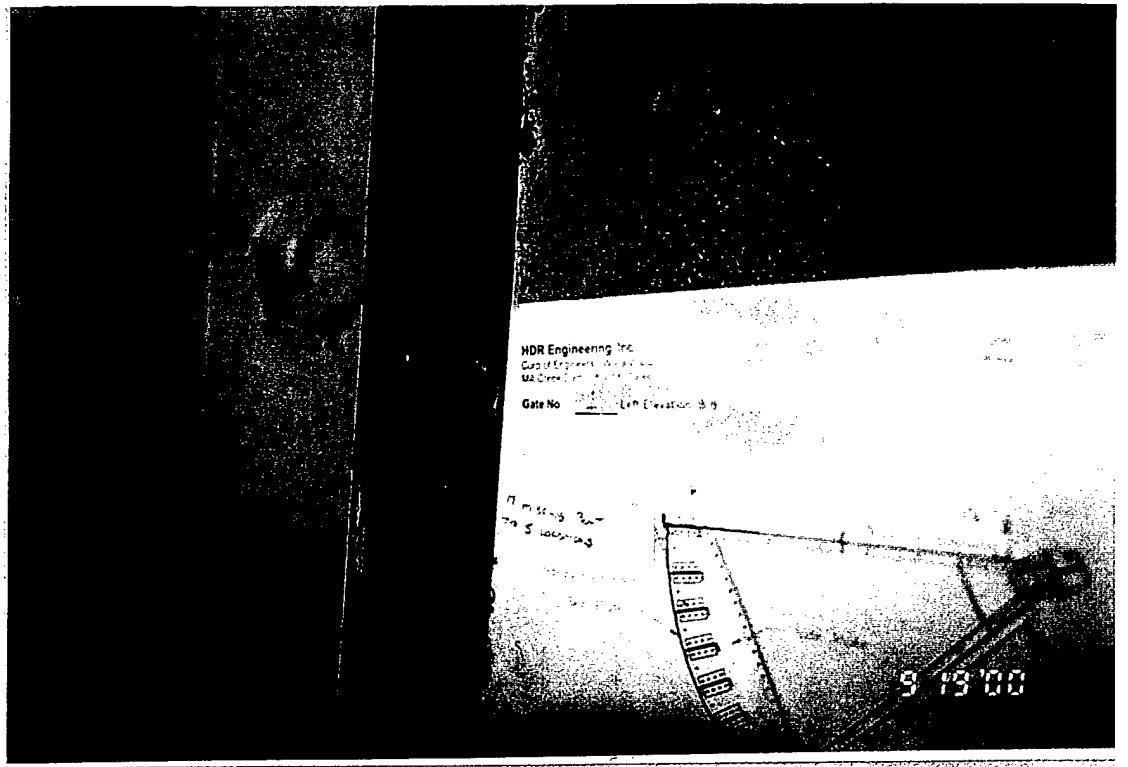

Mill
Creek
Dam

Gate 4 - 8'x18'
Side seal and keeper bar from
upstream, typical.

9/19/00

4-17

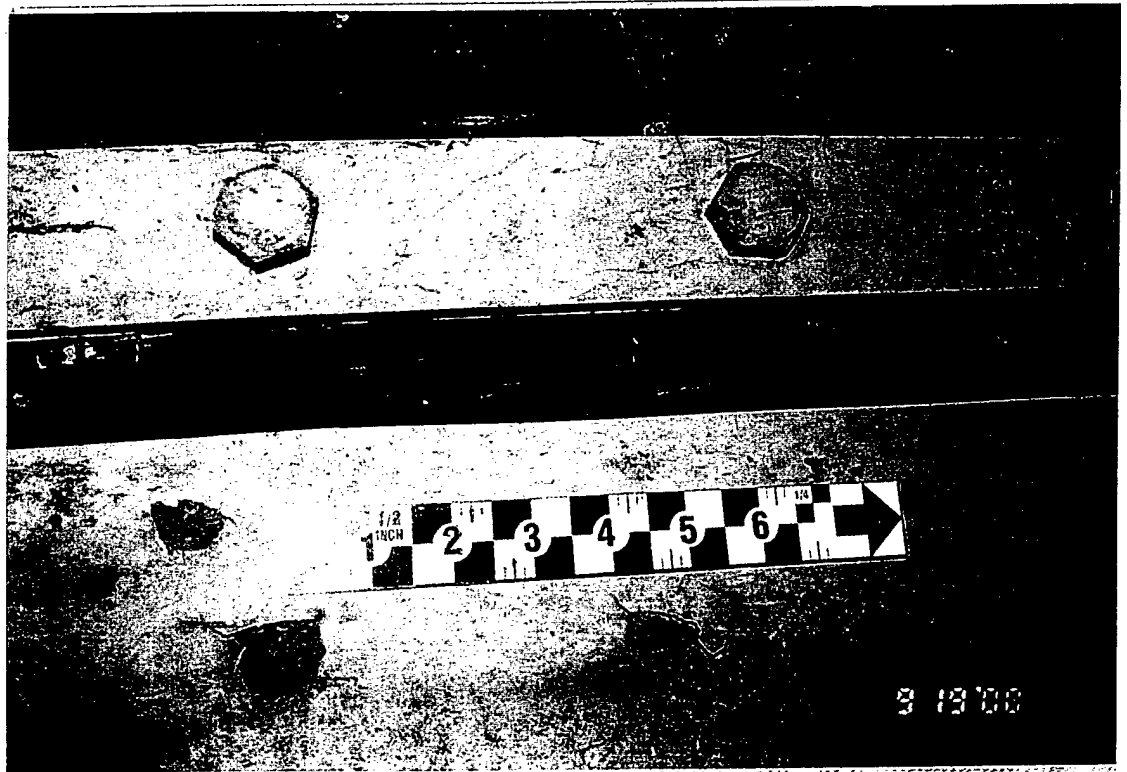

Mill
Creek
Dam

Gate 4 - 8'x18'
Side seal and keeper bar from
upstream. Peeling paint and light
corrosion on skin plate.

9/19/00

4-18

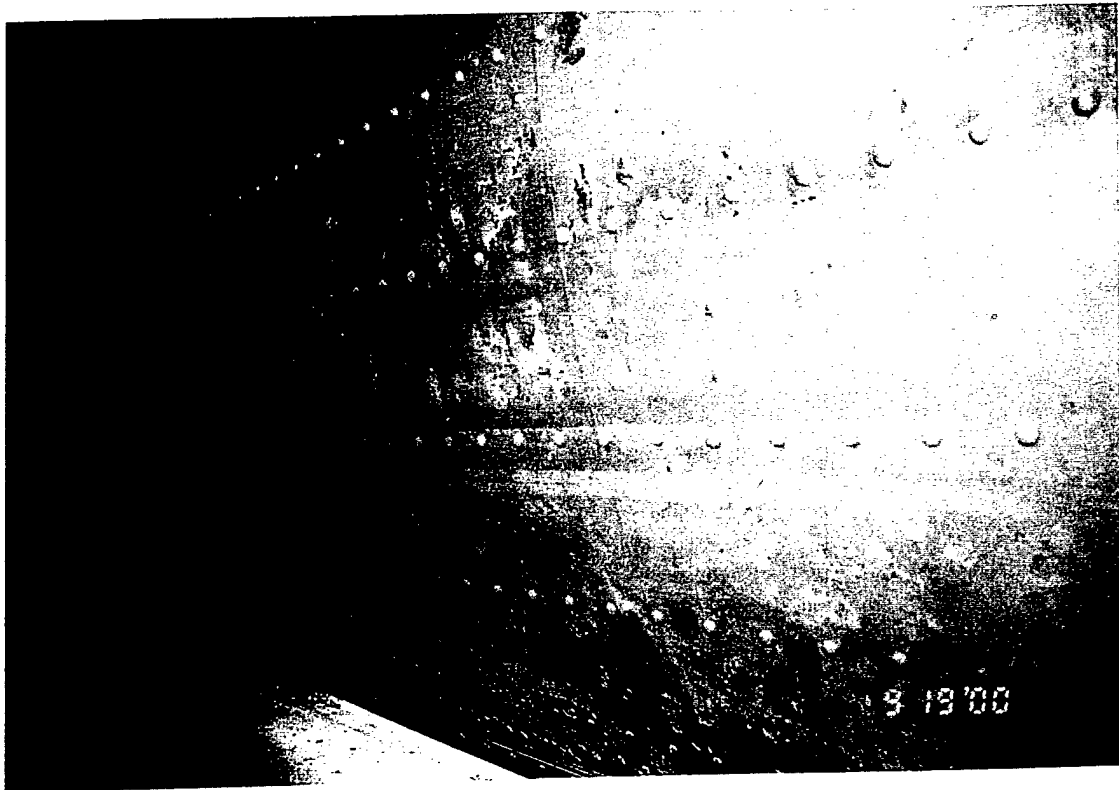

Mill
Creek
Dam

Gate 4 - 8'x18'
Skin plate, typical.

9/19/00

4-19

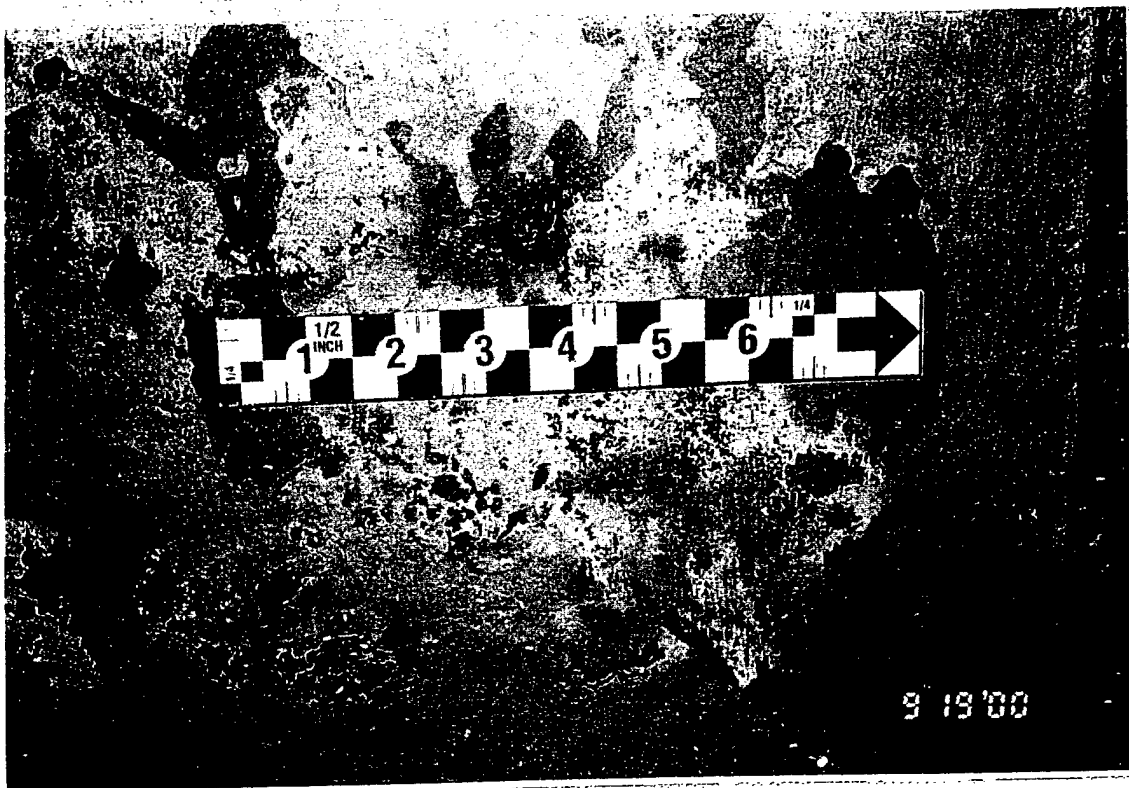

Mill
Creek
Dam

Gate 4 - 8'x18'
Close-up of skin plate, typical.
Peeling paint and light corrosion.

9/19/00

4-20

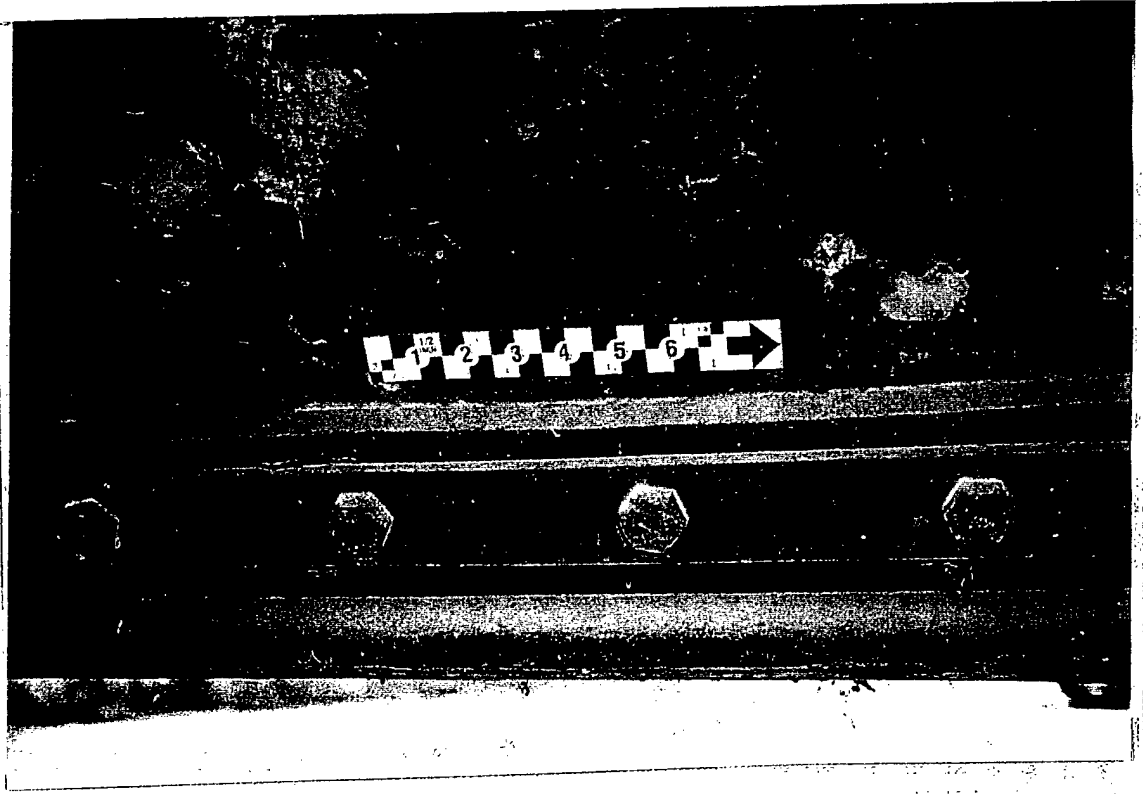

Mill
Creek
Dam

9/19/00

4-21

Gate 4 - 8'x18'
Skin plate at upstream side of bottom
seal, typical. Light corrosion on skin
plate and keeper bar.

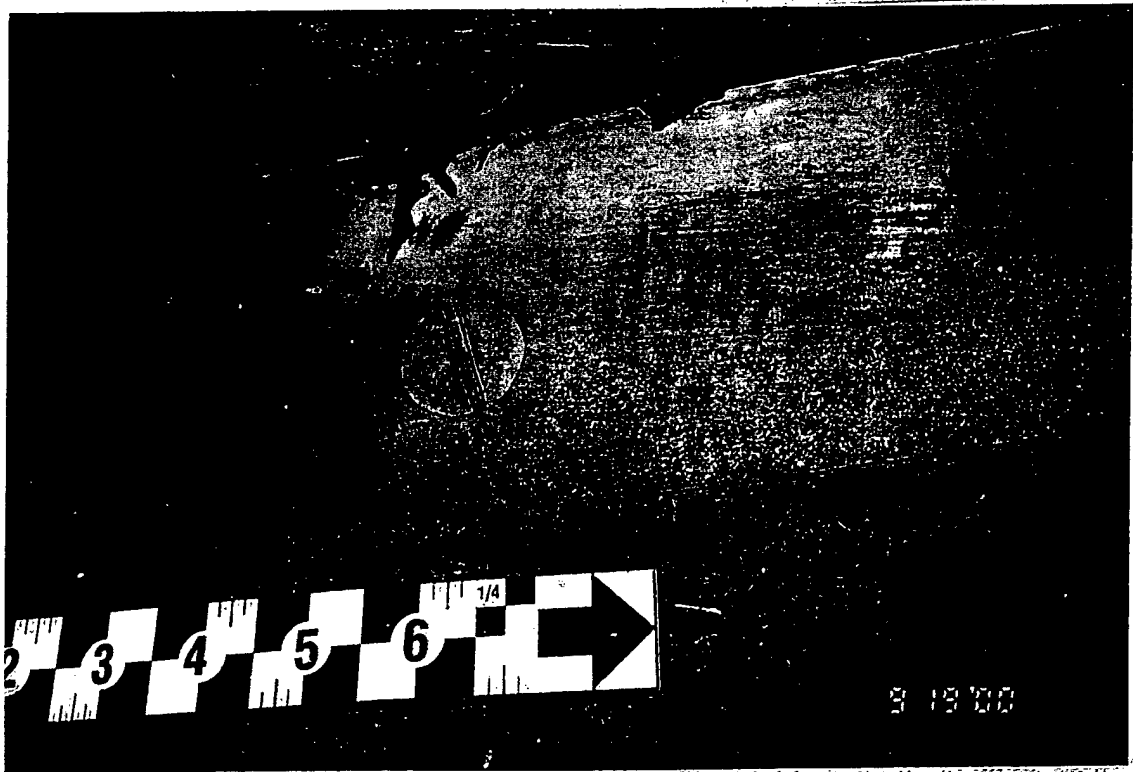

Mill
Creek
Dam

9/19/00

4-22

Gate 4 - 8'x18'
Embedded seal plate, typical.

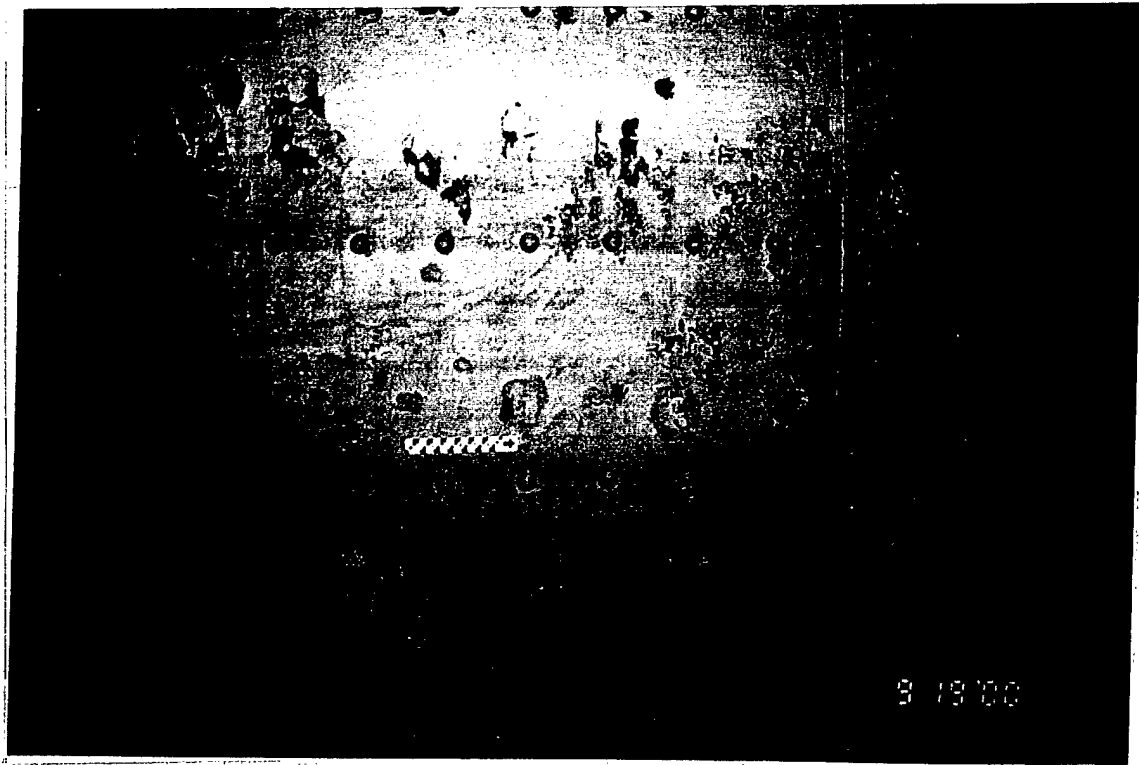

Mill
Creek
Dam

Gate 4 - 8'x18'
Skin plate, typical.

9/19/00

4-23

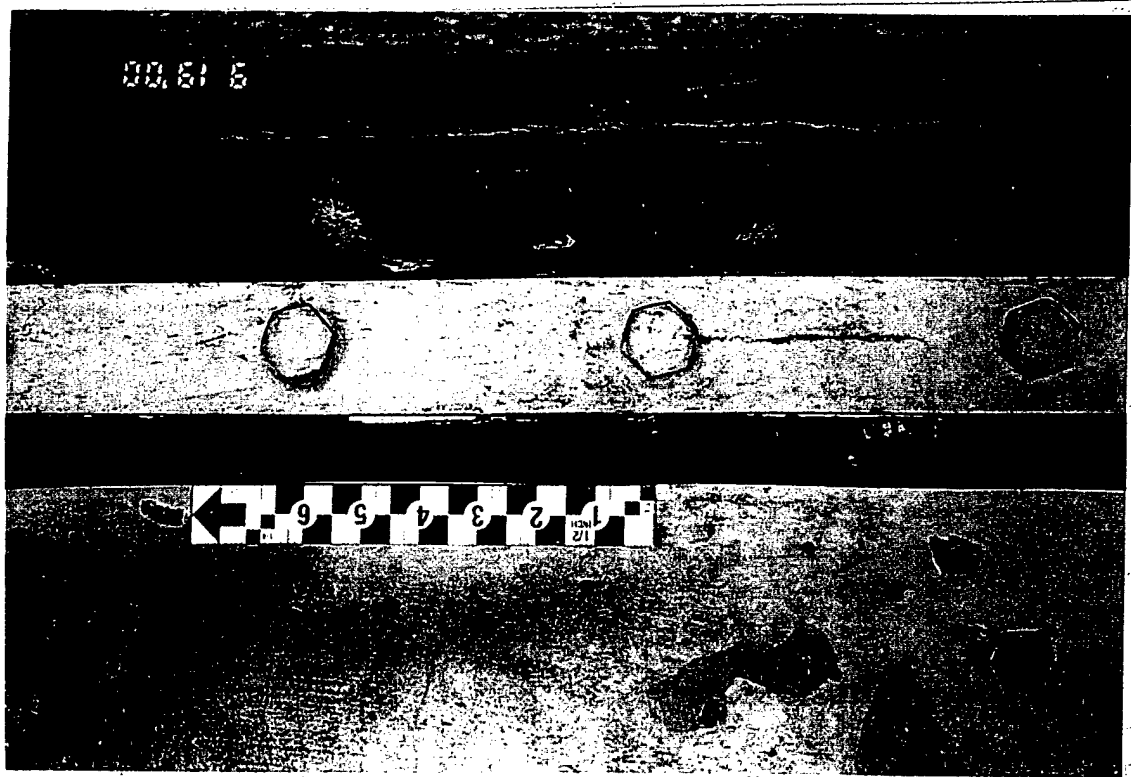

Mill
Creek
Dam

Gate 4 - 8'x18'
Side seal, typical.

9/19/00

4-24²

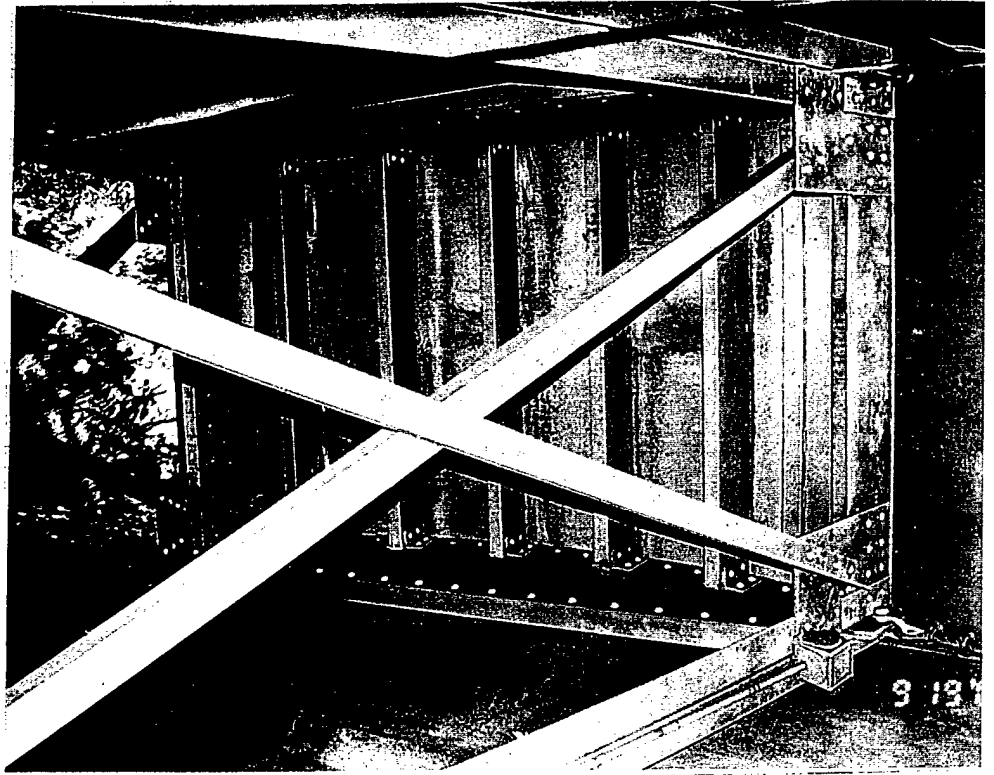

Mill
Creek
Dam

North Radial Gate
Gate face and top bracing, typical.

9/19/00

N-1

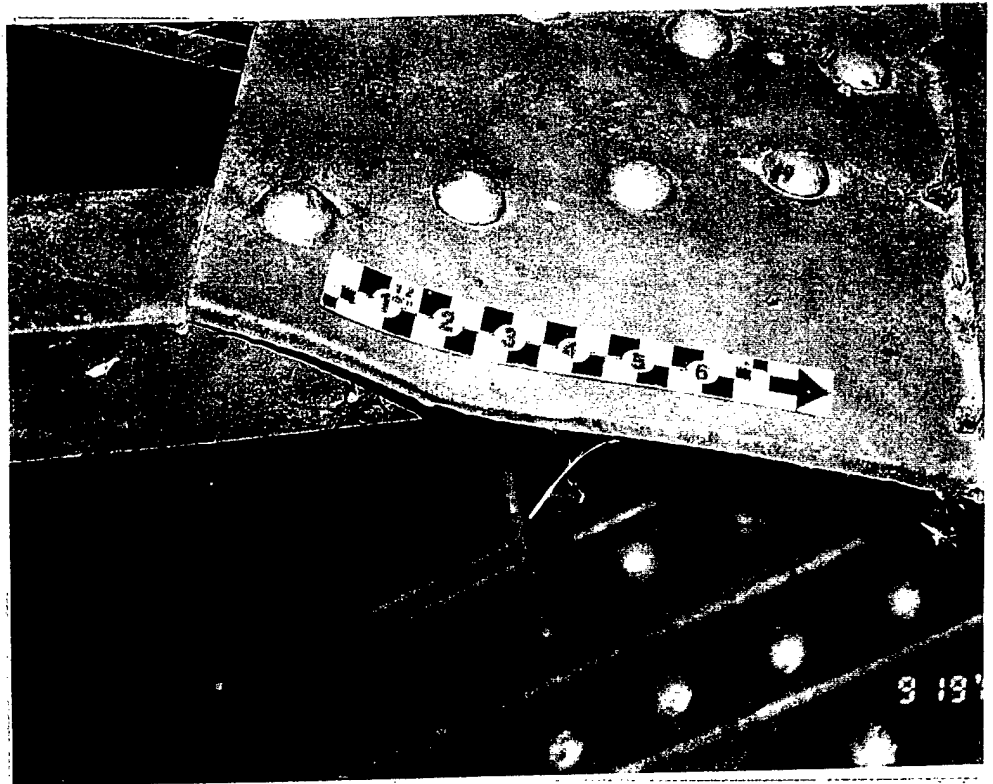

Mill
Creek
Dam

North Radial Gate
Gusset plate connection at top strut
and top bracing, typical.

9/19/00

N-2

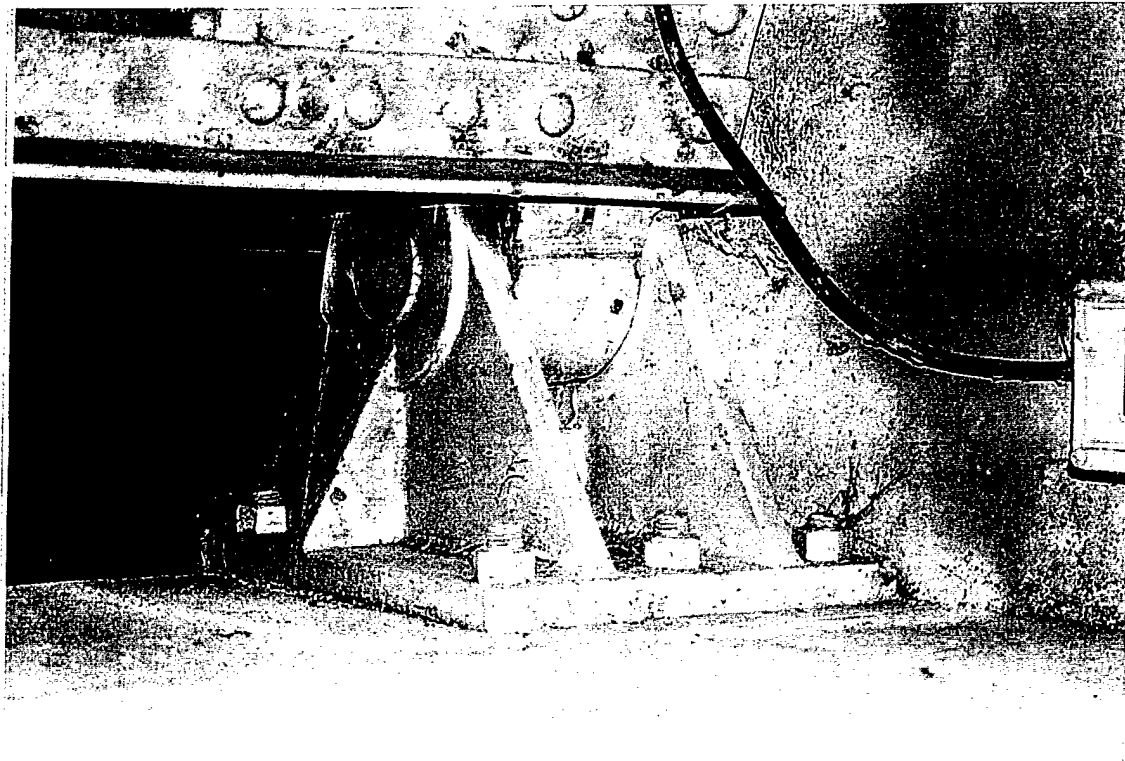

Mill
Creek
Dam

North Radial Gate
Left trunnion, typical.

9/19/00

N-3

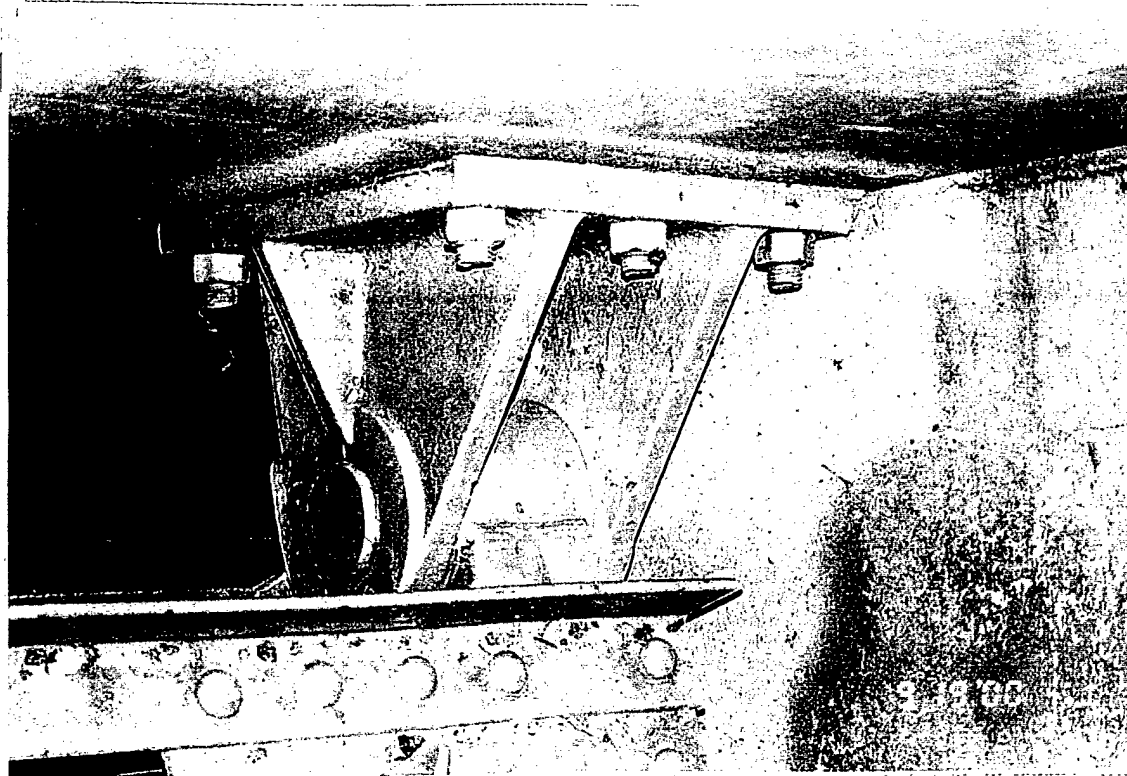

Mill
Creek
Dam

North Radial Gate
Right trunnion, typical.

9/19/00

N-4

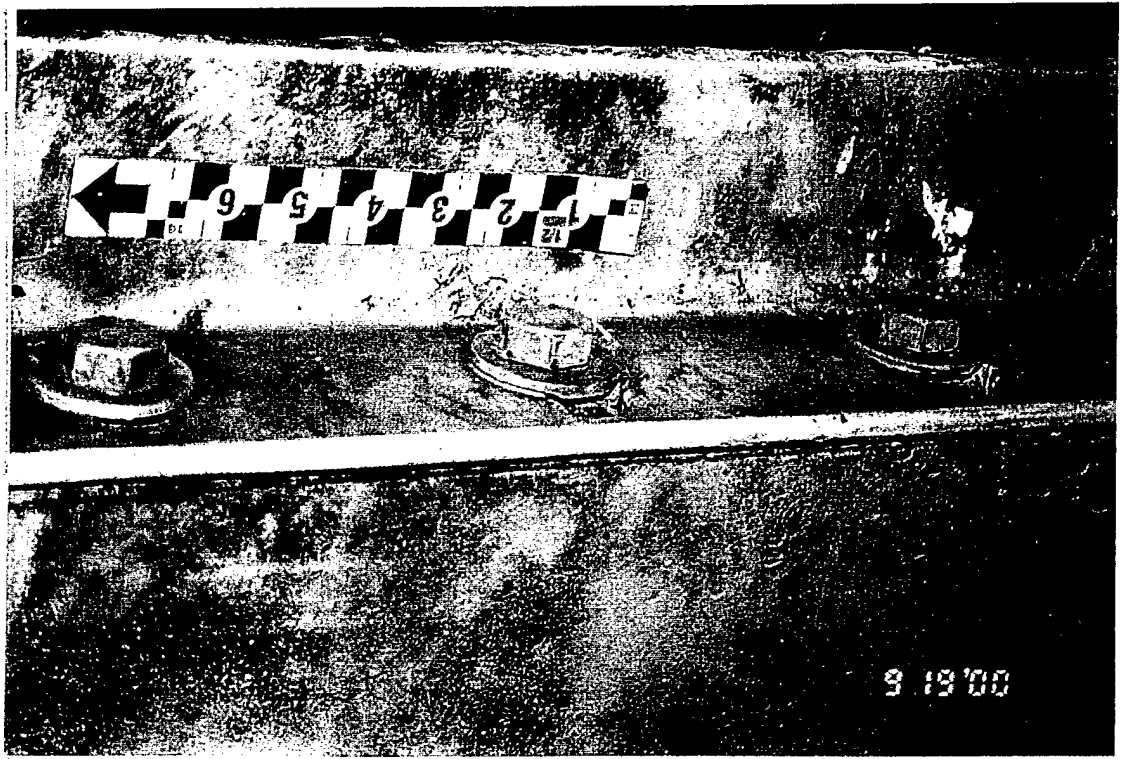

Mill
Creek
Dam

North Radial Gate
Top seal angle connection bolts,
typical. Light isolated corrosion.

9/19/00

N-5

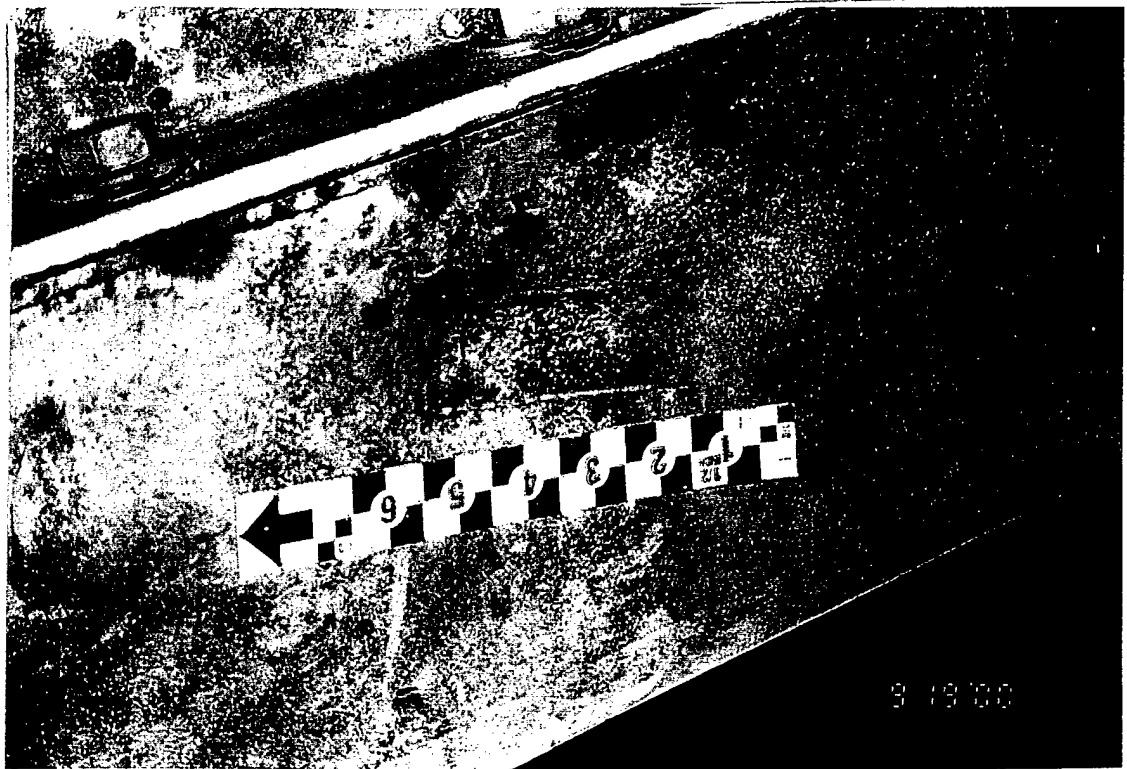

Mill
Creek
Dam

North Radial Gate
Top seal angle, typical.

9/19/00

N-6

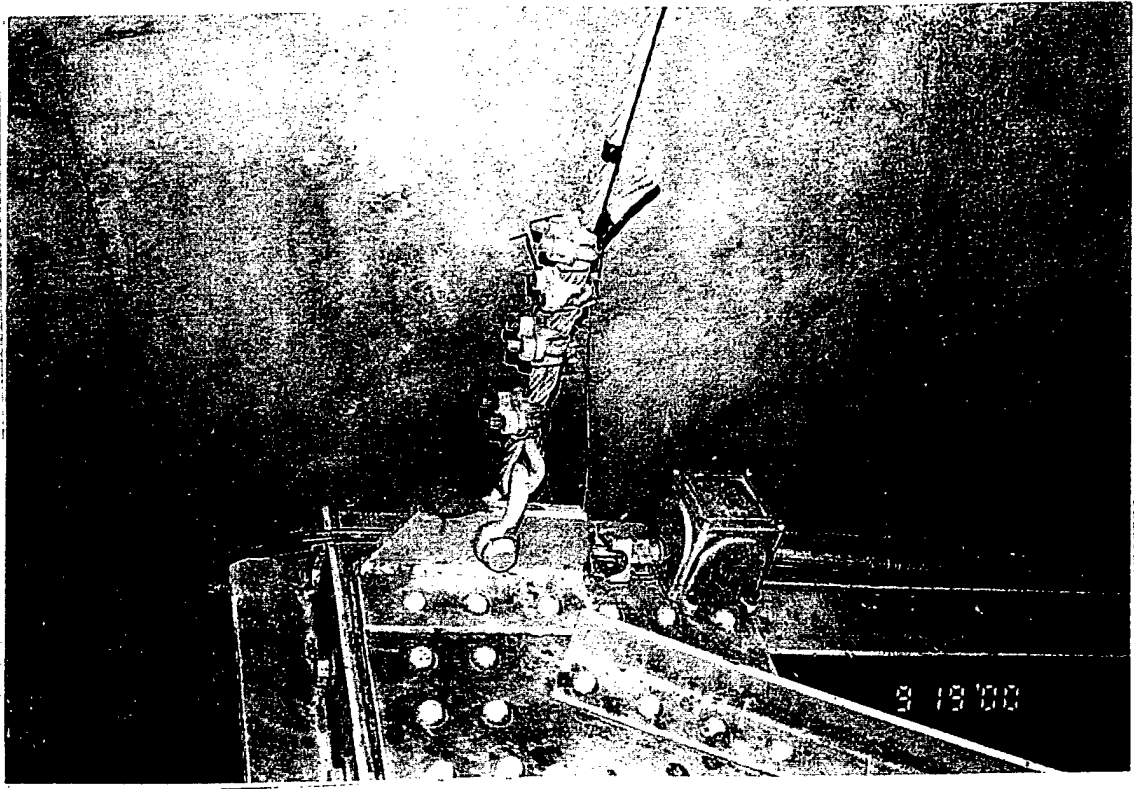

Mill
Creek
Dam

North Radial Gate
Left hoist cable connection, typical.
Side seal heater.

9/19/00

N-7



Mill
Creek
Dam

North Radial Gate
Top of bottom horizontal girder 1.
Debris and light corrosion.

9/19/00

N-8

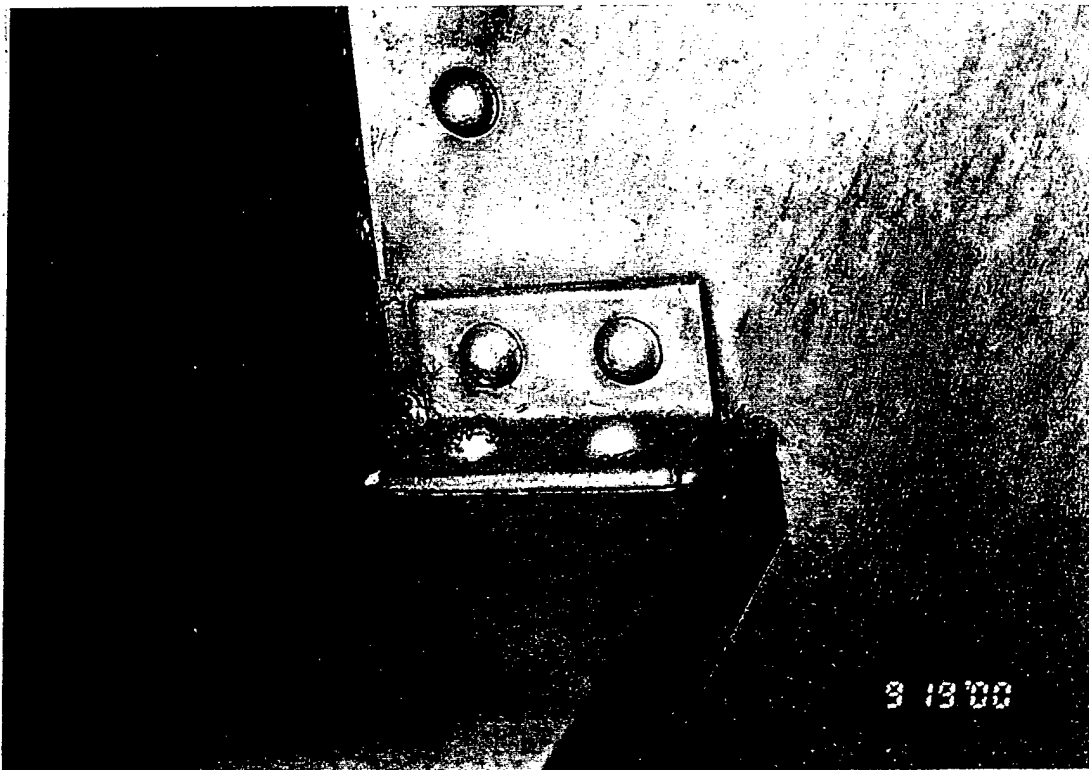

Mill
Creek
Dam

North Radial Gate
Horizontal girder to side plate
connection, typical.

9/19/00

N-9

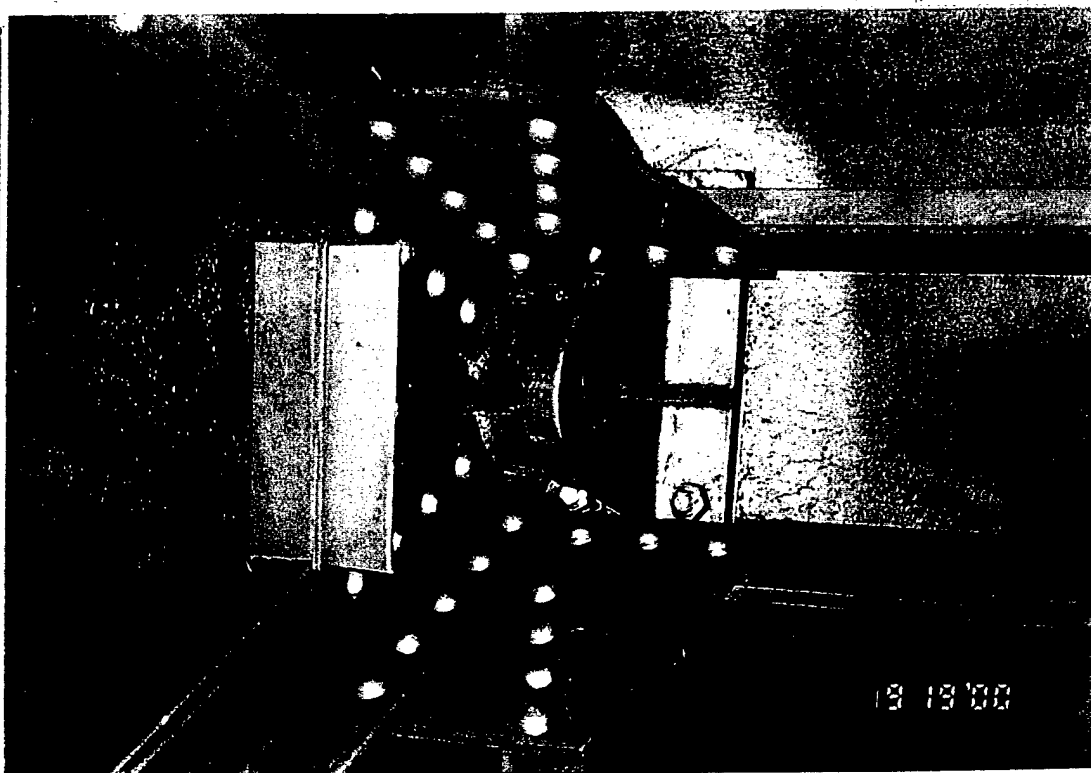

Mill
Creek
Dam

North Radial Gate
Left trunnion, looking downstream,
typical.

9/19/00

N-10

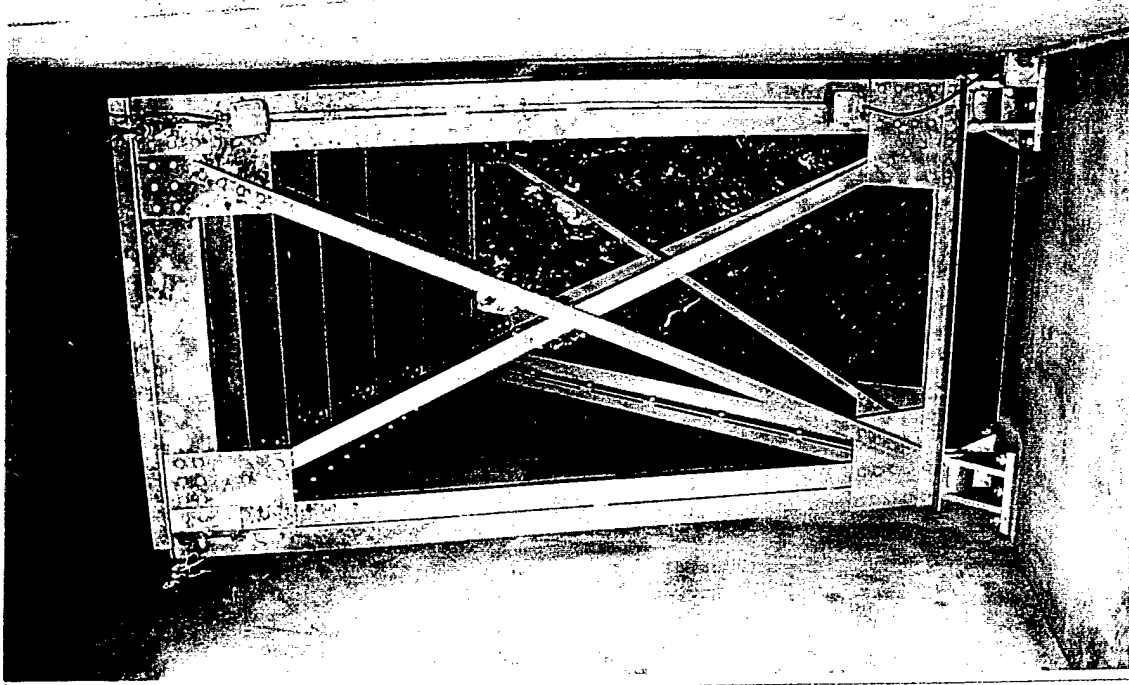

Mill
Creek
Dam

North Radial Gate
Gate overview, from top.

9/19/00

N-11

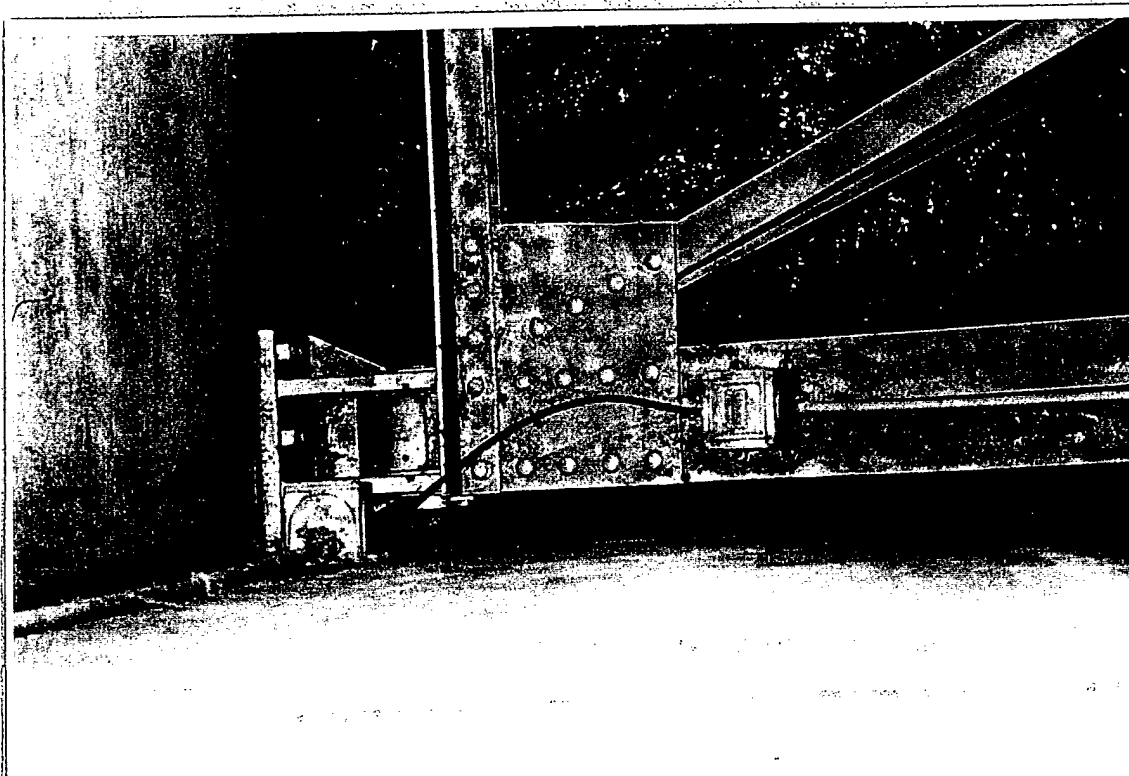

Mill
Creek
Dam

North Radial Gate
Left trunnion and side seal heater,
typical.

9/19/00

N-12

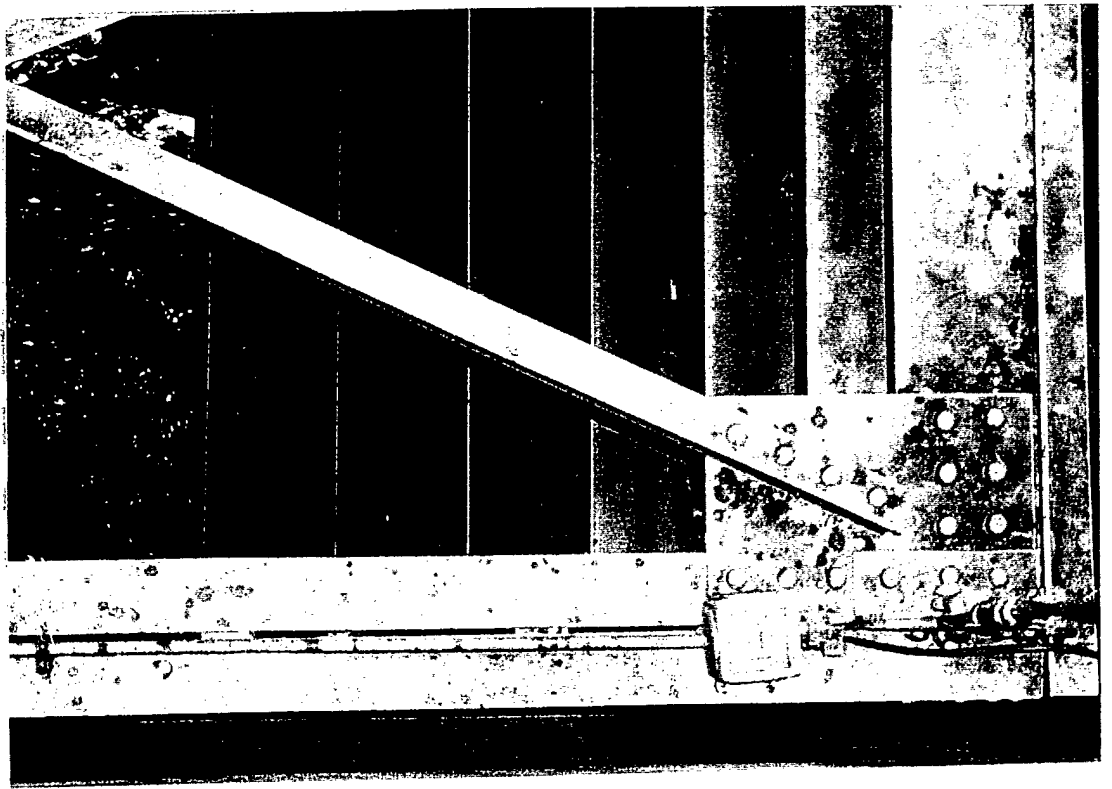

Mill
Creek
Dam

North Radial Gate
Front left corner of gate and side seal
heater, typical.

9/19/00

N-13

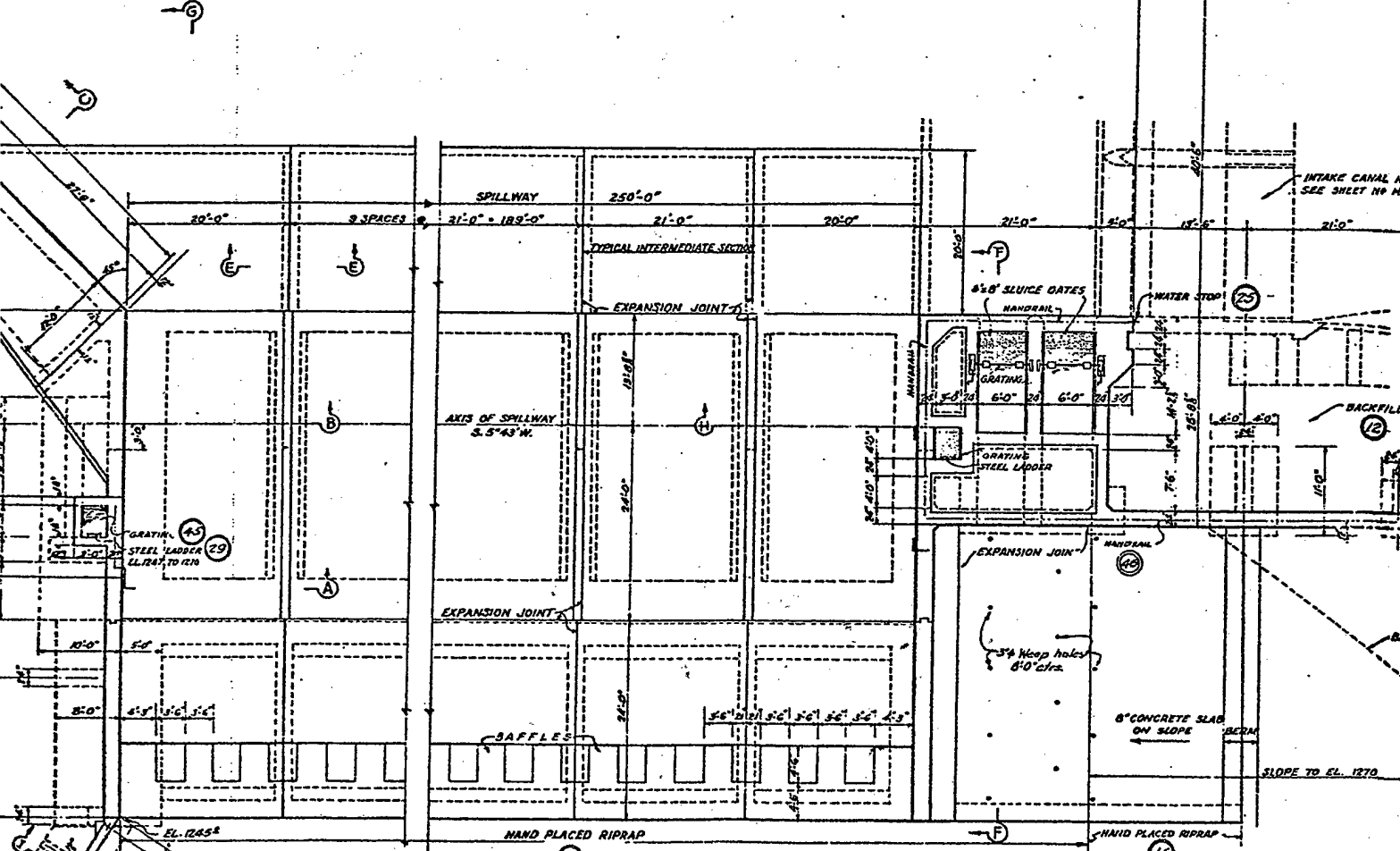
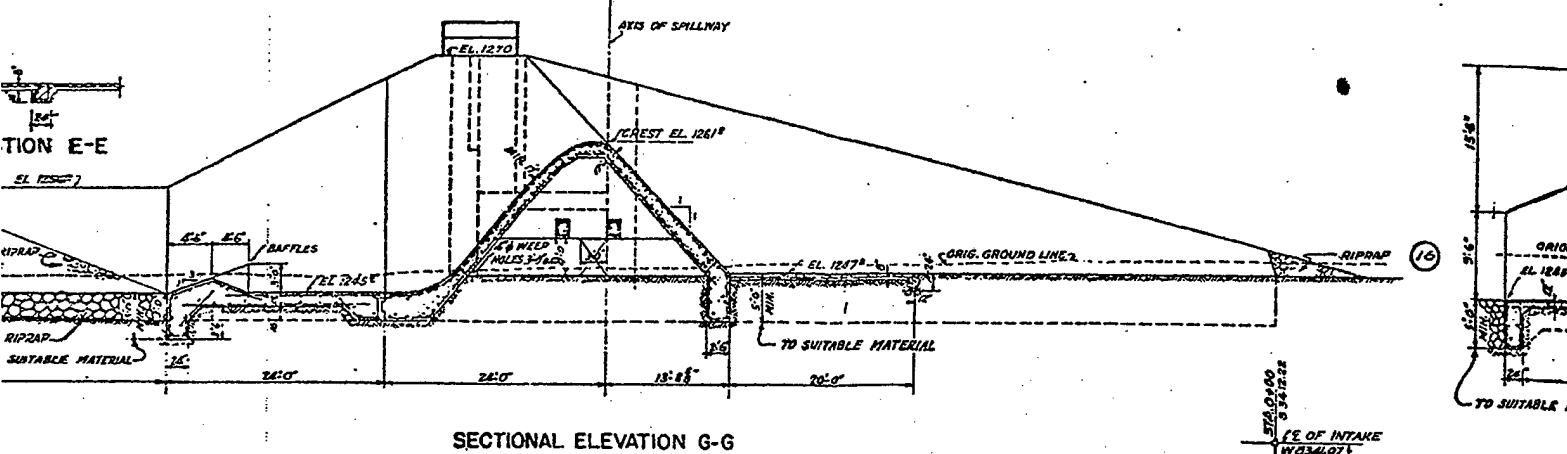

PLAN OF DIVERSION WEIR
SCALE 1/8" = 1 FT.
GRAPHIC SCALE
0 5 10 15 20 25 30 35 FEET

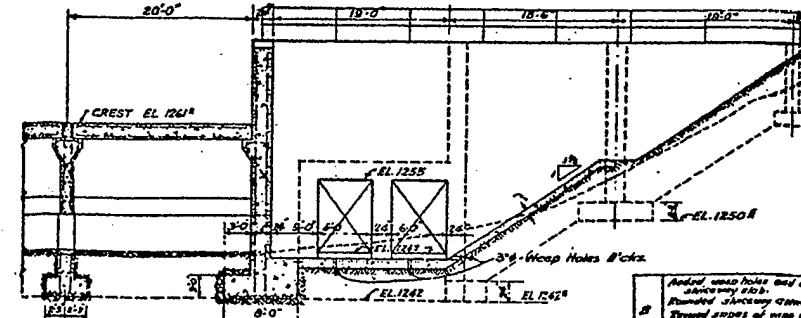

NO.	REVISION
1	Added hoop holes and a 3/4" x 3/4" x 3/4" steel ladder
2	Revised slopes of wing & riprap apron
3	Revised JAC. W. Denny
4	General revision TMB

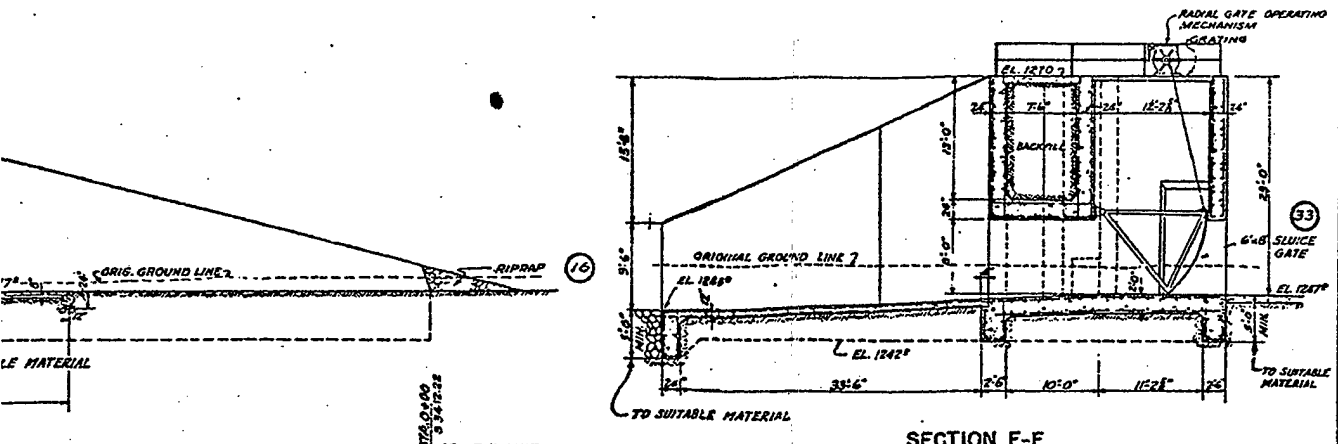

SECTION F-F

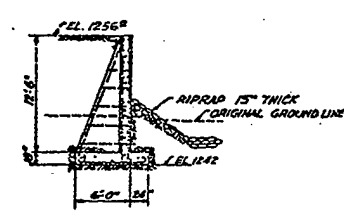
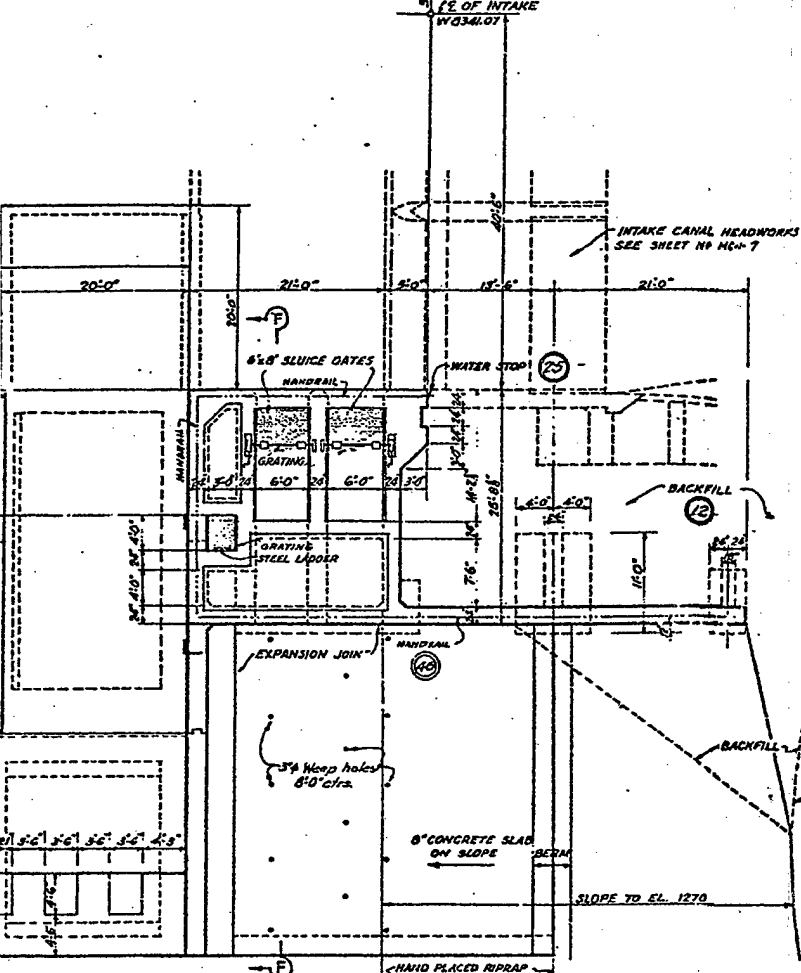

SECTION I-I

FOR INFORMATION ONLY

NOTE:
 WORK REDUCERS, DRUMS, DRUM SHAFTS, PULL BLOCKS,
 COUPLINGS, WIRE ROPES SAME AS SHOWN ON SHEET NO 2
 ALL CONCRETE TO BE CLASS "A"
 Figures in circles indicate item number under
 which payment will be made, thus (1)

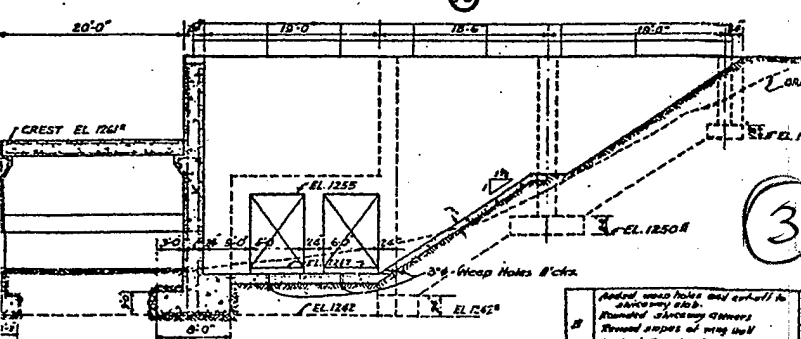

SECTION H-H

MILL CREEK FLOOD CONTROL PROJECT
 WALLA WALLA COUNTY, WASH.
DIVERSION STRUCTURE
 SHEET NO. 39

PREVIOUSLY NUMBERED
 A-10-10
 W-1-9
 F-10-18

SCALE AS NOTED
 U. S. ENGINEER OFFICE, SECOND PORTLAND DISTRICT (OREGON)

NO.	REVISION	DATE	APVD
1	General revision made	8-26-39	E.C.B.

APPROVED: *[Signature]*
 RECOMMENDED: *[Signature]*

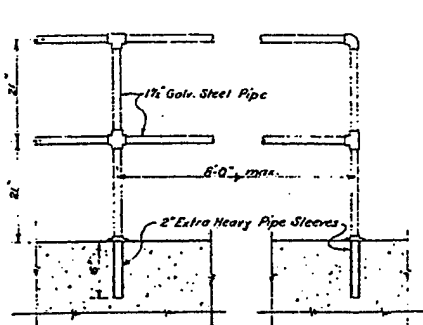

HAND RAILING (19)
SCALE 3/4"=1'-0"

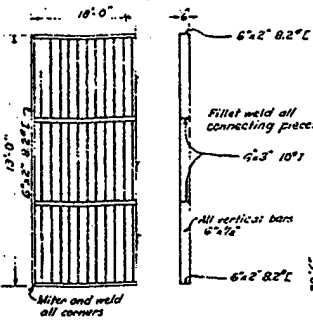

TRASH RACK (20)
SCALE 3/4"=1'-0"

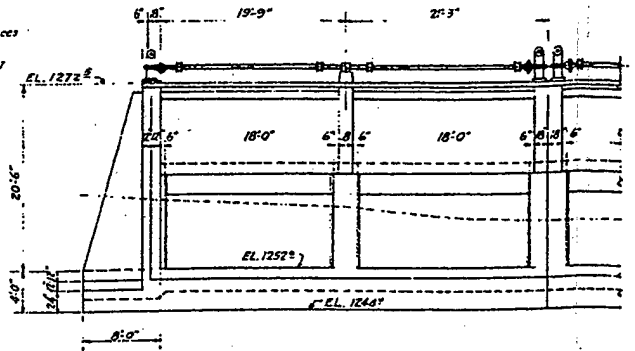

SECTION B-B
SCALE 1/2"=1'-0"
GRAPHIC SCALE

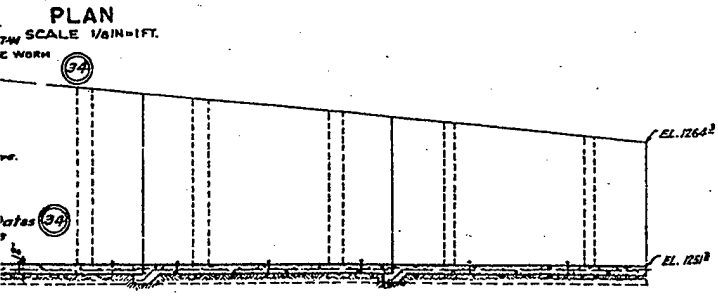
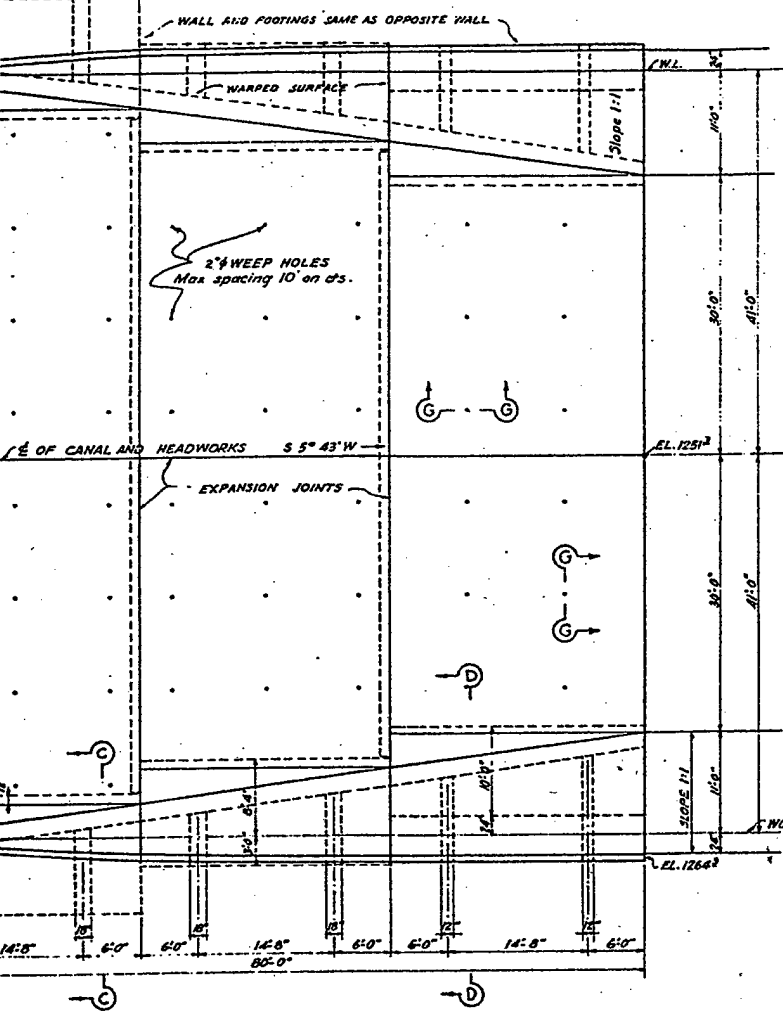

SECTION A-A

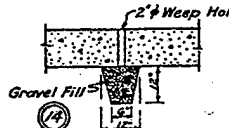

SECTION G-G
SCALE 1/2"=1'-0"

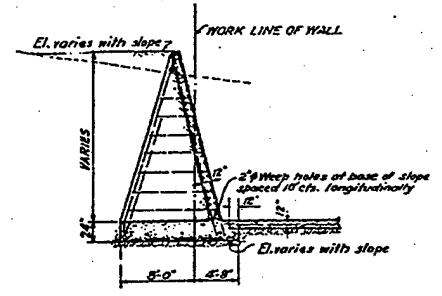

SECTION C-C

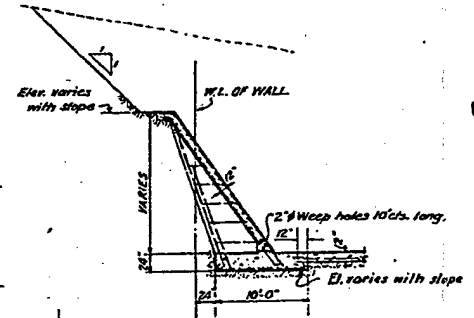

SECTION D-D

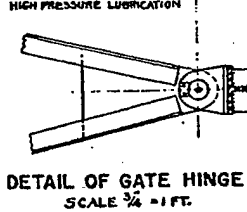
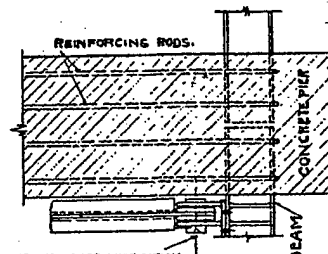

DETAIL OF GATE HINGE
SCALE 3/4"=1'-0"

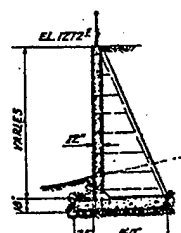

SECTION E-E

FOR INFORMATION

NOTE:
ALL CONCRETE T FIGURES IN CIRCLED A NUMBER UNDER WHICH P MADE, THUS (1)

B	Trash rack detail as Anchor ribs reversed, S Bars added, Section Intake carriers run, Weep holes added, Sec
A	General revision made
NO.	REVISION

(2)

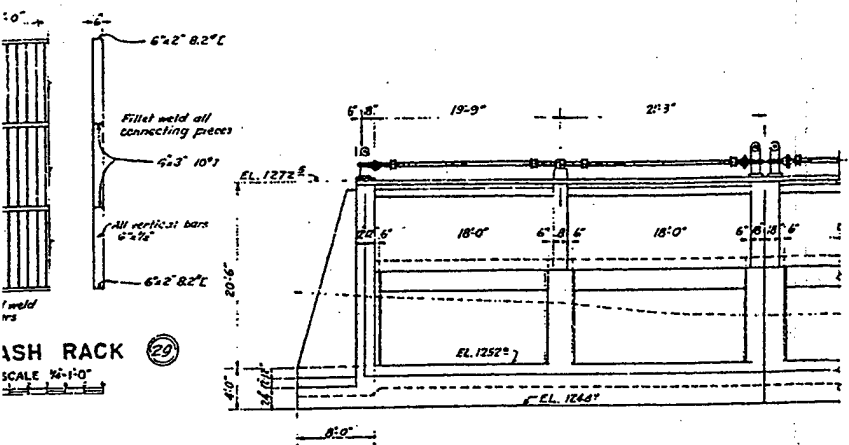

TRASH RACK
SCALE 1/4" = 1'-0"
②

SECTION B-B
SCALE 1/8" = 1'-0"
GRAPHIC SCALE
0 5 10 20 FEET

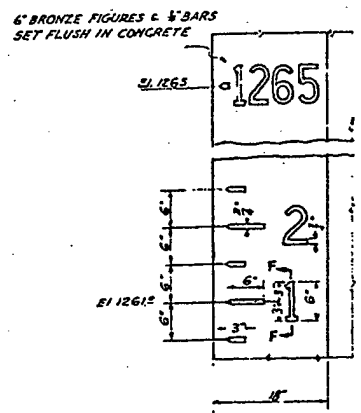

DETAIL OF FIGURES
SCALE 1" = 1'-0"

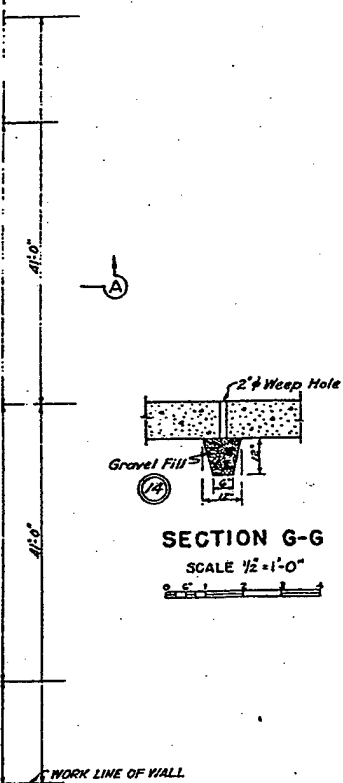

SECTION G-G
SCALE 1/2" = 1'-0"
GRAPHIC SCALE

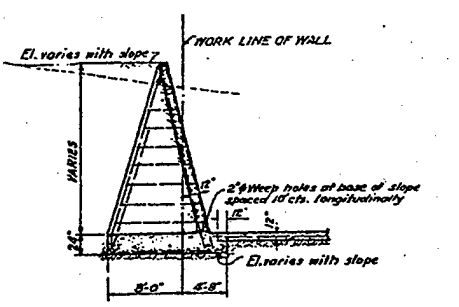

SECTION C-C

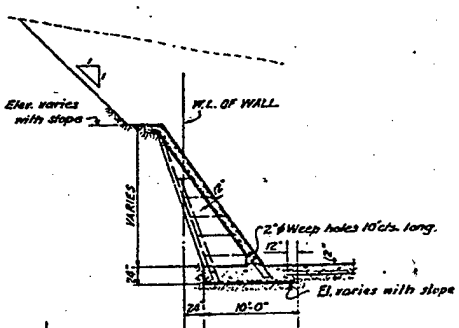

SECTION D-D

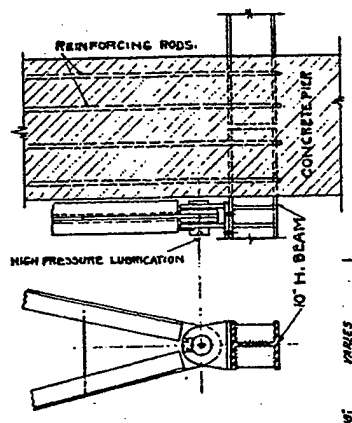

DETAIL OF GATE HINGE
SCALE 3/4" = 1'-0"

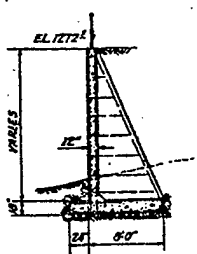

SECTION E-E

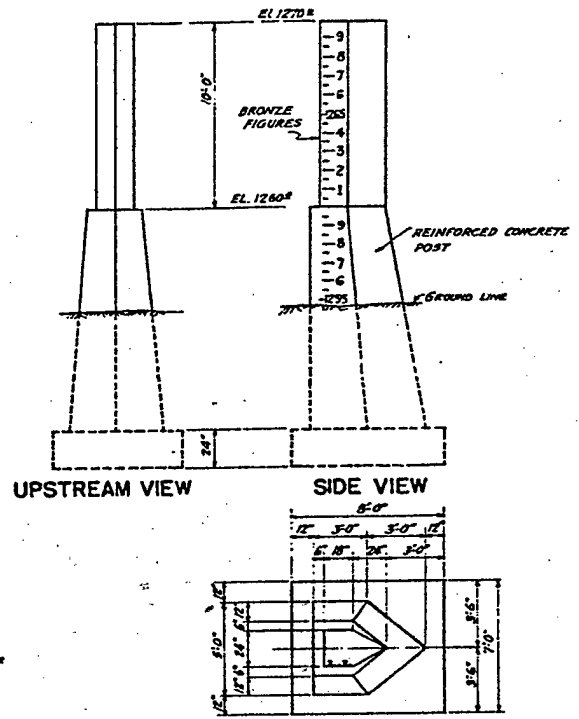

UPSTREAM VIEW

SIDE VIEW

PLAN

FOR INFORMATION ONLY

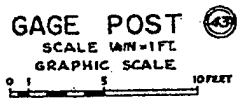

GAGE POST
SCALE 1/4" = 1'-0"
GRAPHIC SCALE
0 5 10 FEET

NOTE:
ALL CONCRETE TO BE CLASS "A"
Figures in circles indicate items
numbered under which payment will be
made, thus (1)

PREVIOUSLY NUMBERED F-15-16
A-10-11
W-1-10

②

MILL CREEK FLOOD CONTROL PROJECT
WALLA WALLA COUNTY, WASH.

INTAKE CANAL HEADWORKS

SCALE AS NOTED SHEET NO. 40

U. S. ENGINEER OFFICE, SECOND PORTLAND DISTRICT (OREGON)

APPROVED: [Signature]
APPROVED: [Signature]

RECOMMENDED: [Signature]
REVISION: [Signature]

NO.	REVISION	DATE	APYD
B	Trash rack detail added Anchor ribs reversed, Sect. A-A Berm added, Section D-D Weep holes added, Sect. G-G	2-23-30	PSH
A	General revision made	8-26-30	A.G.S.

③

WAR DEPARTMENT

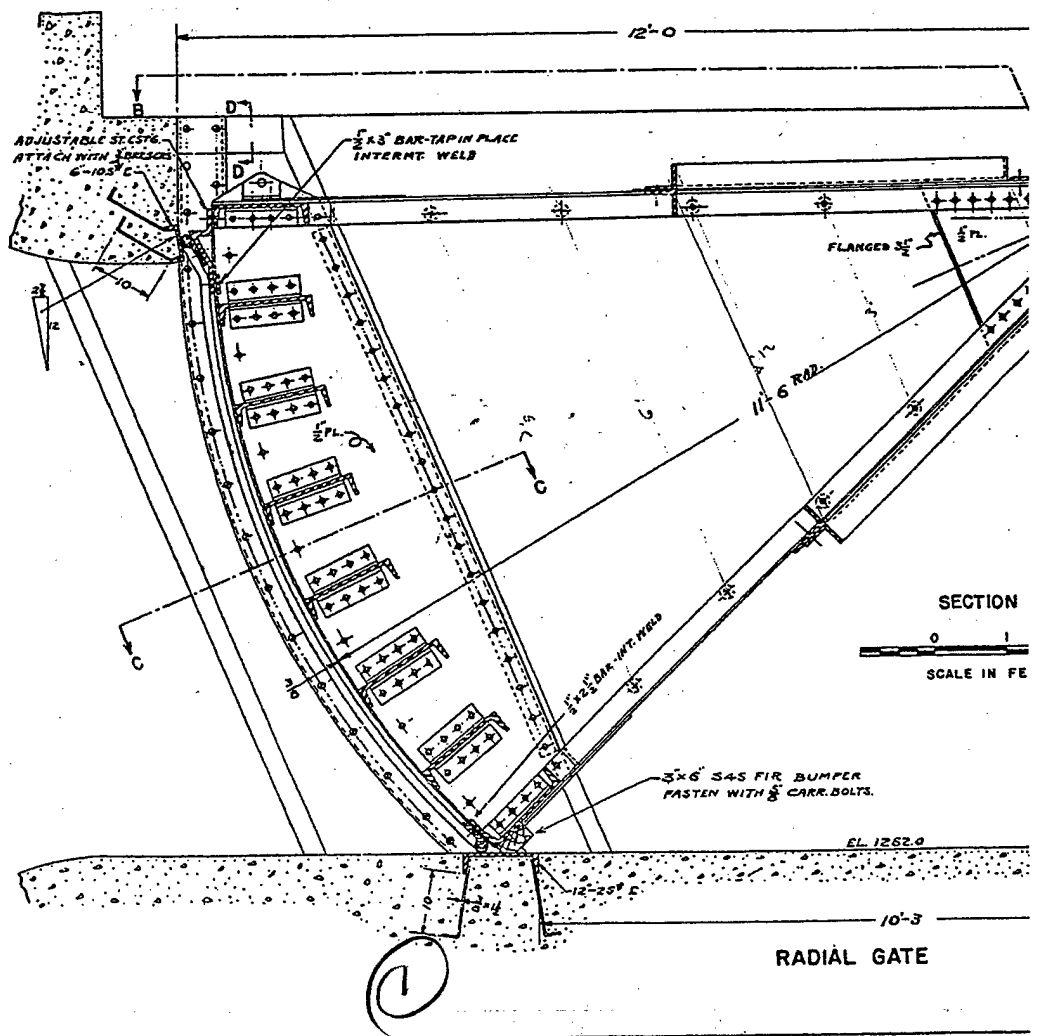
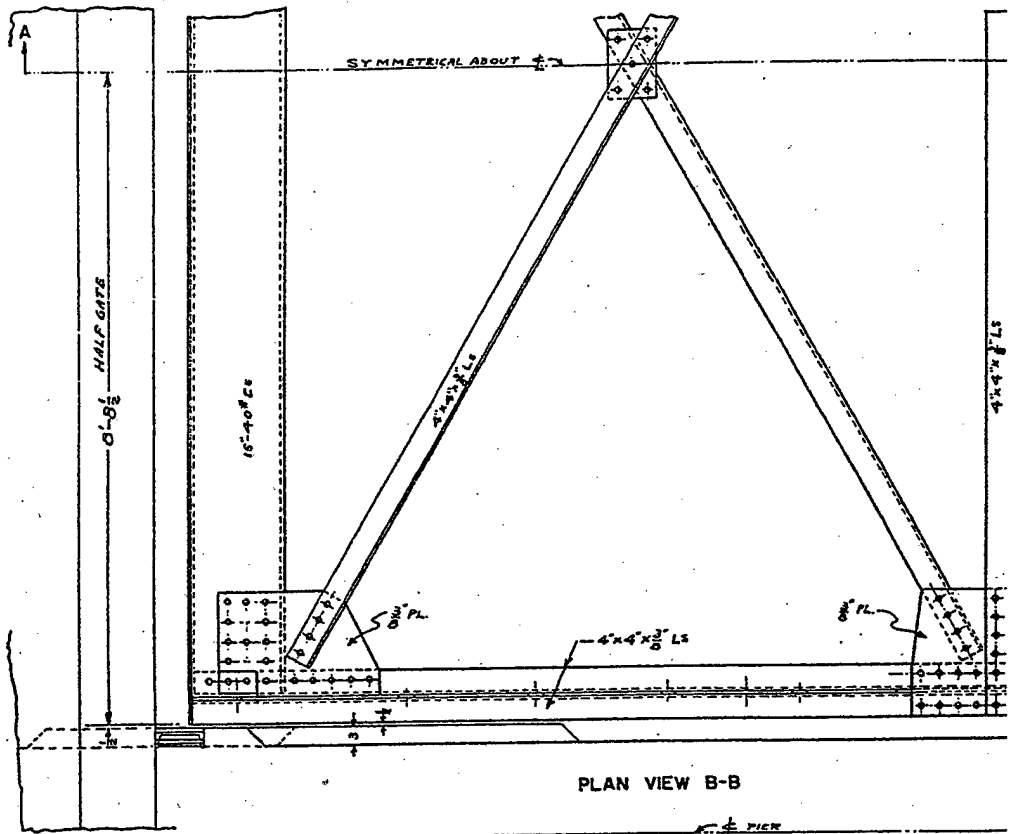

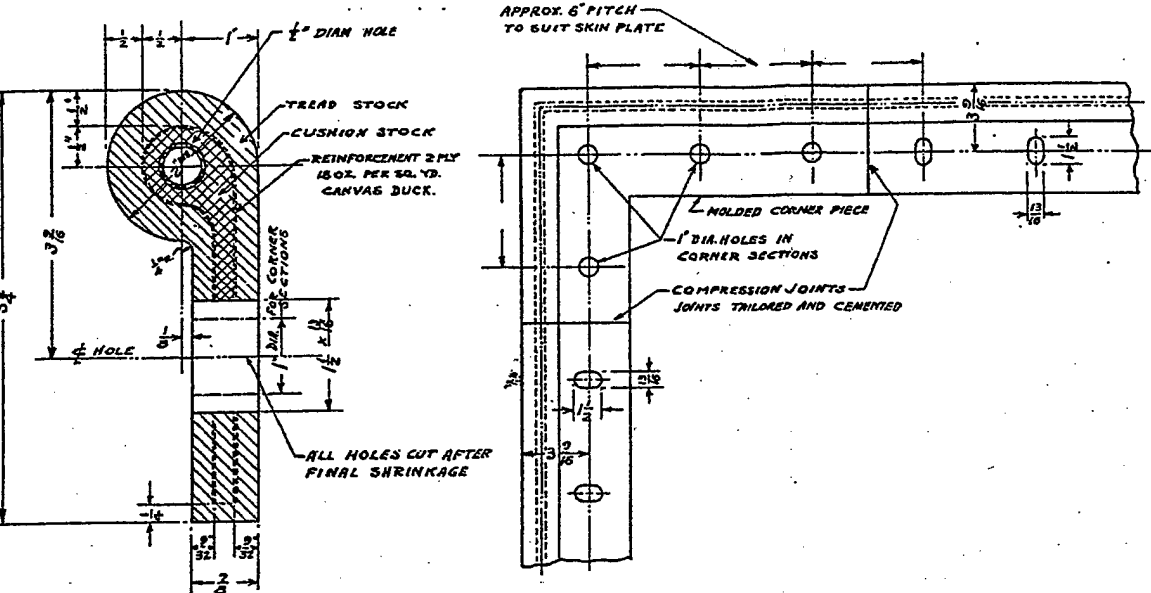

DETAIL OF "J" RUBBER

TYPICAL SEAL CORNER

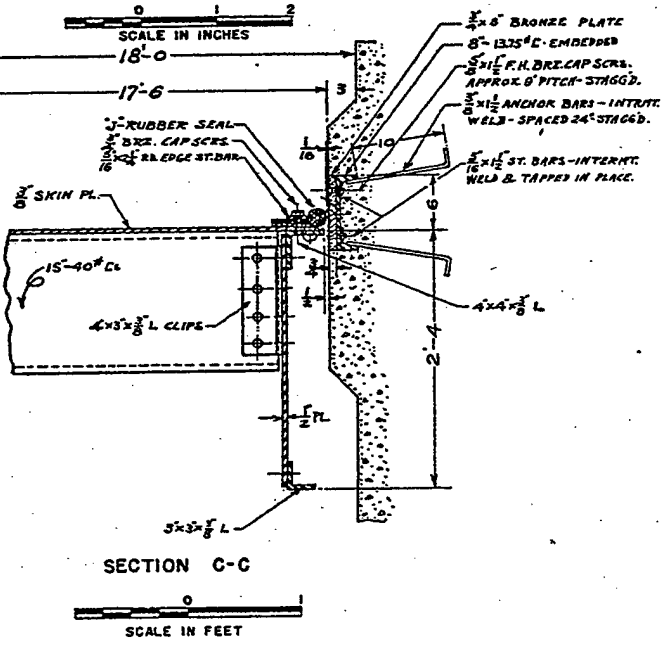

SCALE IN INCHES

SECTION D-D

SCALE IN INCHES

SECTION C-C
SCALE IN FEET

FOR INFORMATION ONLY

NOTE:
Figures in circles indicate item number under which payment will be made, thus ①

REQUIRED FOUR GATES AS SHOWN FOR INTAKE
CANAL HEADWORKS ③

③

APPROVED FOR CONSTRUCTION		MILL CREEK FLOOD CONTROL PROJECT	
MAJOR, CORPS OF ENGINEERS		WALLA WALLA COUNTY, WASH.	
		RADIAL GATES 8'-0" x 18'-0"	
		SHEET NO. 12 41	
		U.S. ENGINEER OFFICE, BONNEVILLE DISTRICT (OREGON)	
MINOR REVISION TO 'J' RUBBER SEAL		APPROVED:	THORNTON
SIDE SEAL REVISIONS SEE D.D. 3-140 P.P.H.		RECOMMENDED:	REYNOLDS
NO.	REVISION	DATE	APYD
		PRINCIPAL ENGINEER	DR. BY: G.R.B. TO BY: G.A.B. CHECKED BY: V...

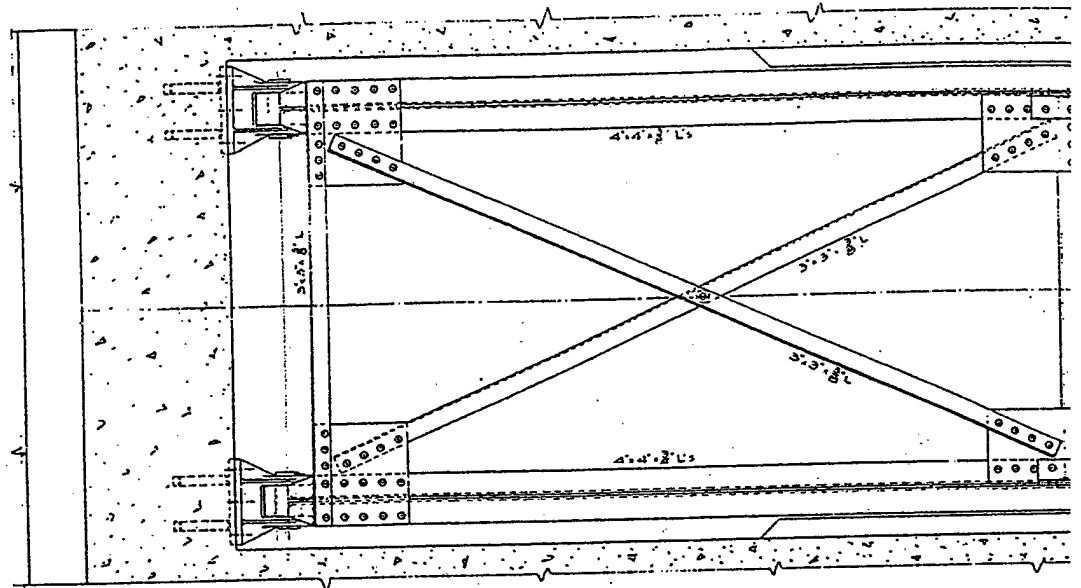

PLAN "A-A"
SCALE: 1"=1'-0"

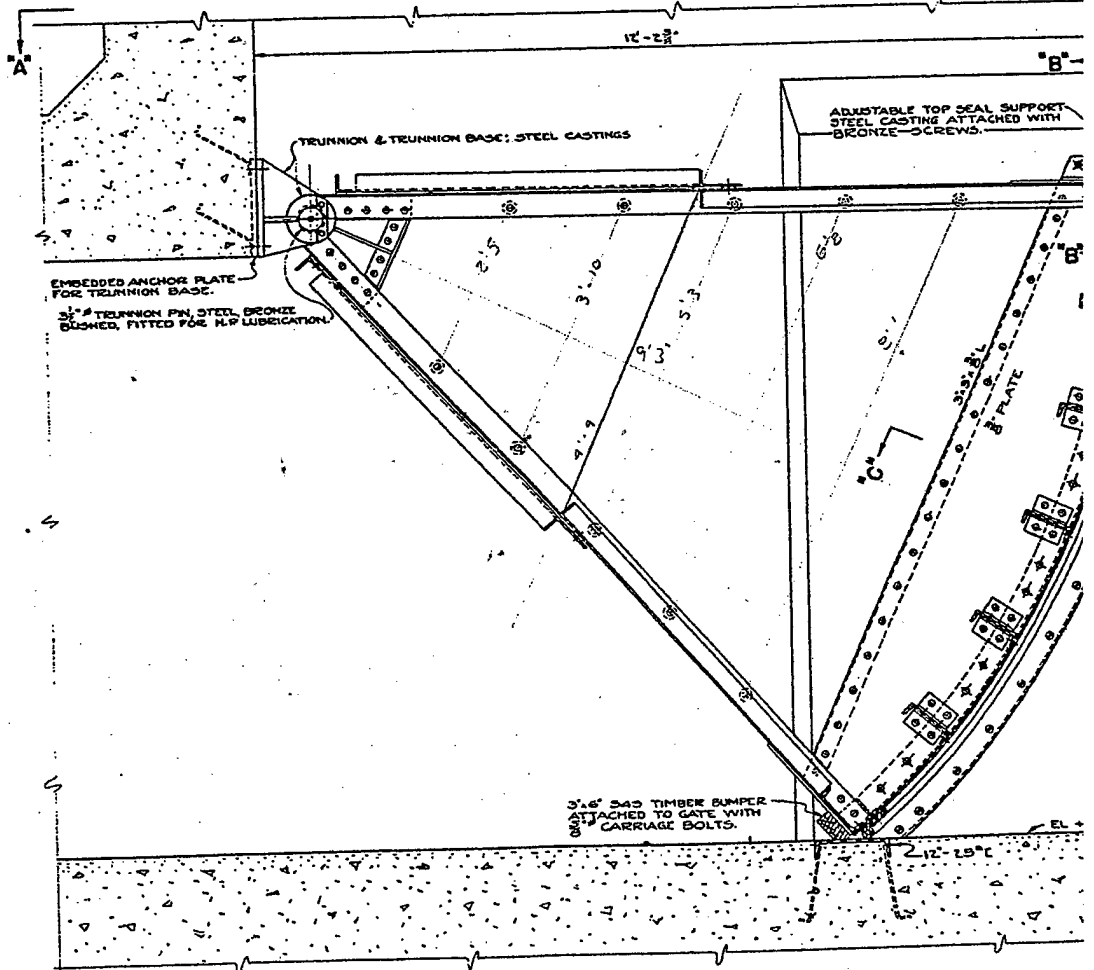

MID-SECTIONAL ELEVATION OF RADIAL GATE

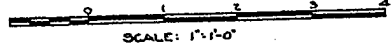

SCALE: 1"=1'-0"

1

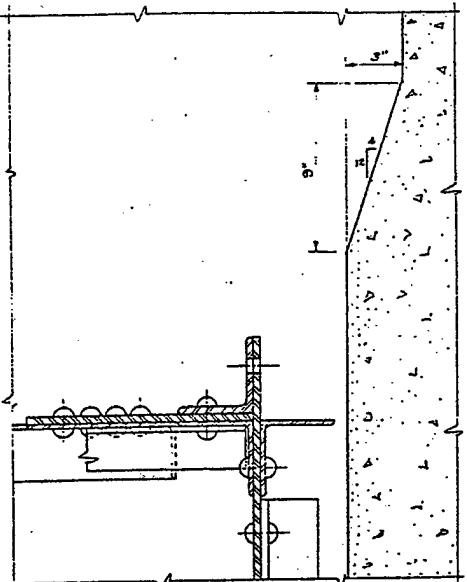
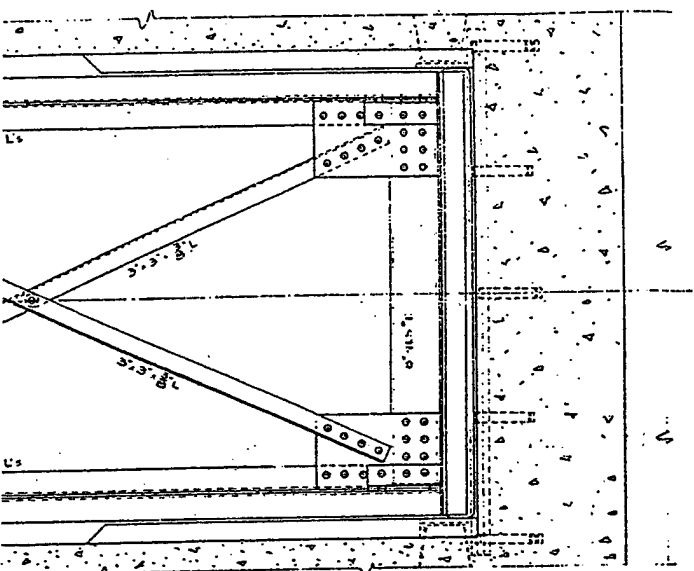

SECTION "B-B"
SCALE: 3"=1'-0"

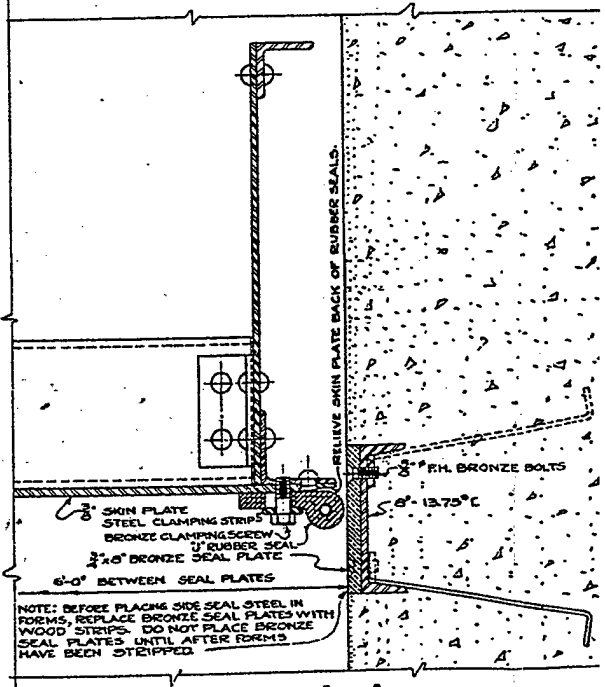
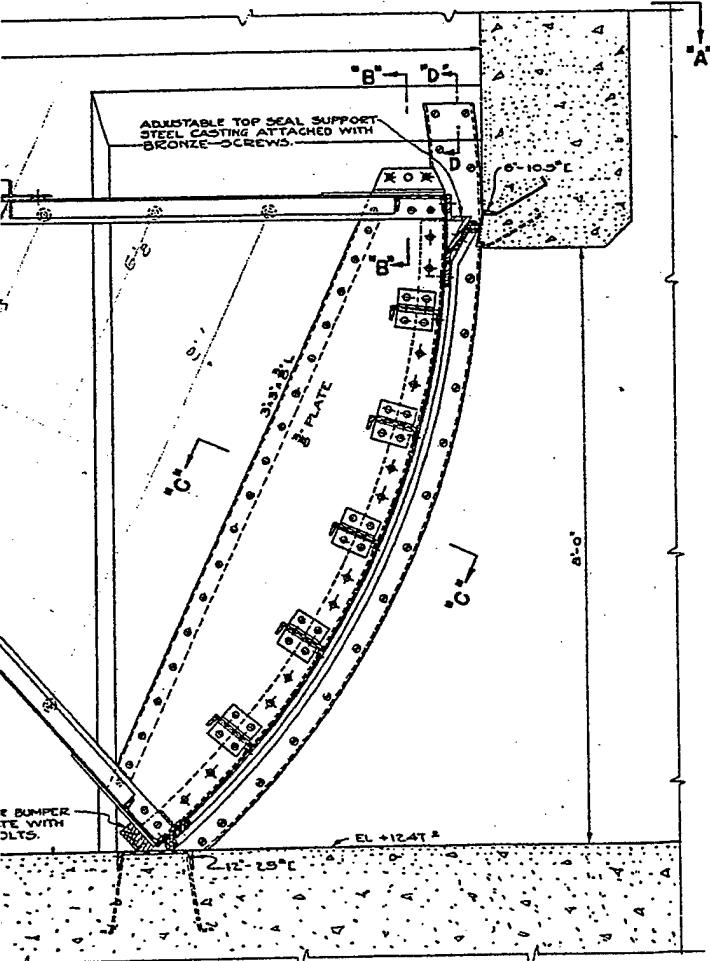

SECTION "C-C"
SCALE: 3"=1'-0"

NOTE: BEFORE PLACING SIDE SEAL STEEL IN FORMS, REPLACE BRONZE SEAL PLATES WITH WOOD STRIPS. DO NOT PLACE BRONZE SEAL PLATES UNTIL AFTER FORMS HAVE BEEN STRIPPED.

OF RADIAL GATE

2

APPROVED FOR CONSTRUCTION

NO.	REVISION

By: [Signature] Date: [Date]

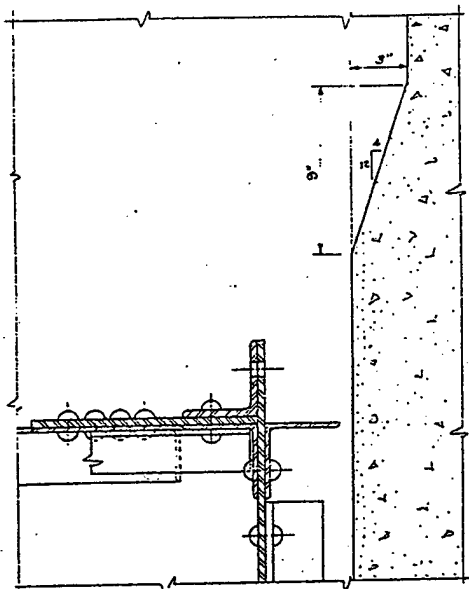

SECTION "B-B"
SCALE: 3" = 1'-0"

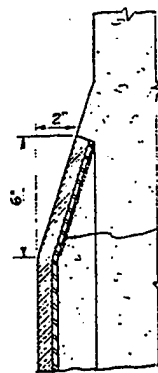

SECTION "D-D"
SCALE 3" = 1'-0"

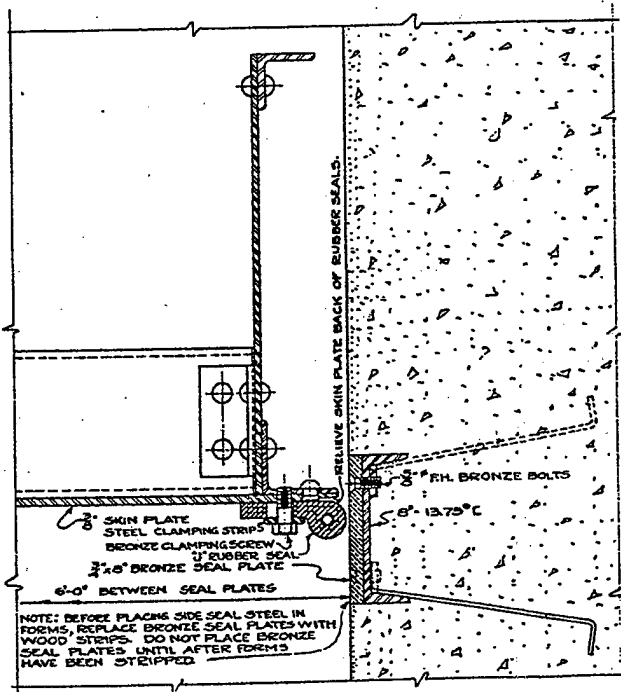

SECTION "C-C"

SCALE: 3" = 1'-0"

REFERENCES:
SEE DRAWING MC-1-12 FOR DETAIL OF RUBBER SEAL.

FOR INFORMATION ONLY

NOTE:
Figures in circles indicate item number under which payment will be made, thus (1)

REQUIRED TWO GATES AS SHOWN FOR DIVERSION STRUCTURE (3)

(3)

APPROVED FOR CONSTRUCTION
MAJOR, CORPS OF ENGINEERS

MILL CREEK FLOOD CONTROL PROJECT
WALLA WALLA COUNTY, WASH.

RADIAL GATES 6'-0" x 8'-0"

SHEET NO. 13

U.S. ENGINEER OFFICE BONNEVILLE DISTRICT (OREGON)

SUBMITTED BY: *[Signature]* APPROVED BY: *[Signature]*

RECOMMENDED BY: *[Signature]* DESIGNED BY: H.G.L. DATE: 8-12-39

DR. BY: H.G.L. CHECKED BY: H.G.L.

NO.	REVISION	DATE	APVD
A	Seal Pl revised - Sec "D" details	3-1-40	P.H.

MC-1-13

Filmed

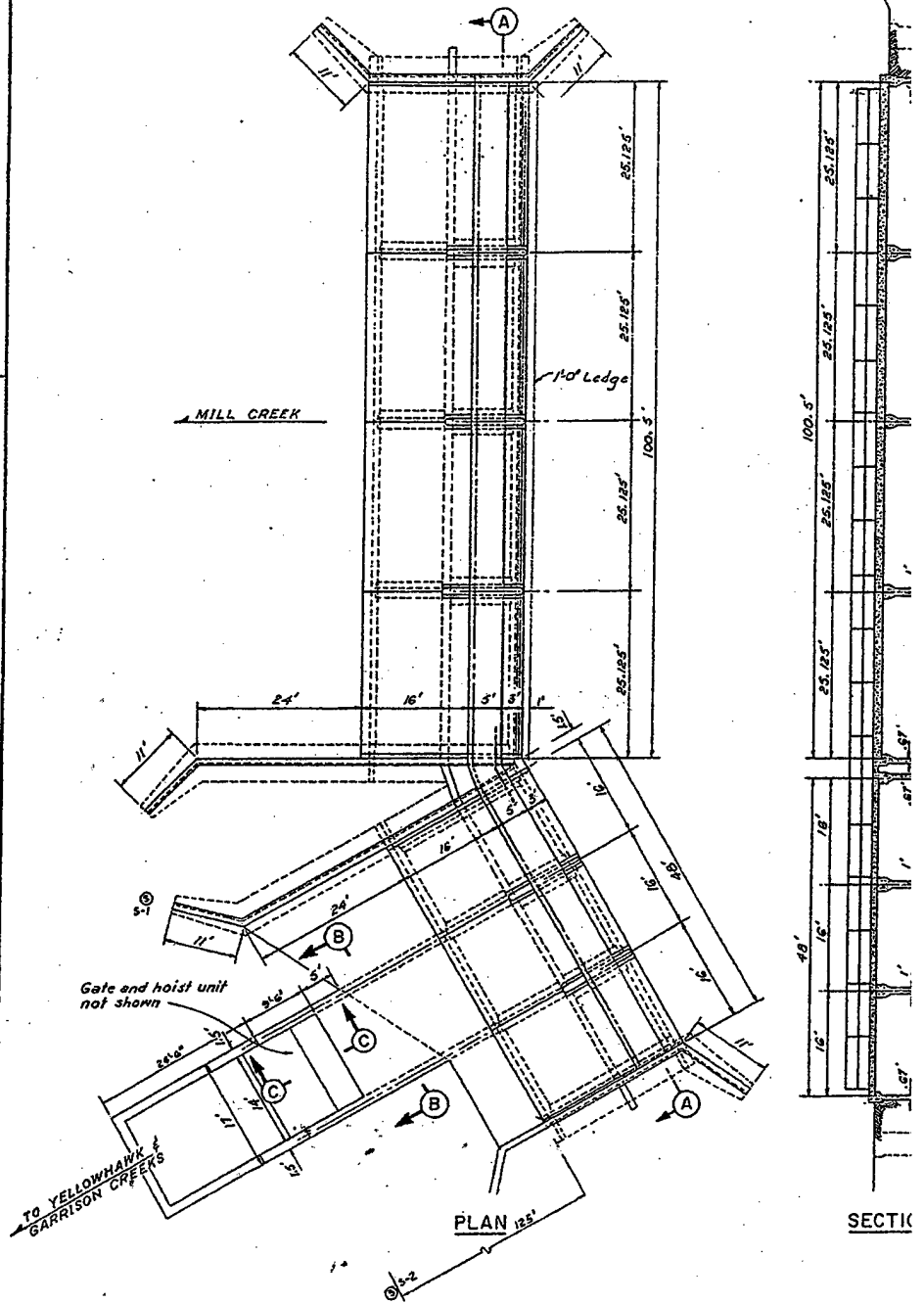

MILL-GARRISON DIVISION STRUCTURE

SCALE IN FEET
 0 4 8 12 16 20 24 28

REFRACTION SEISMOGRAPH EXPLORATION							
LINE NO.	DATE	GEOPHONE LOCATION	LENGTH (FEET) AND DIRECTION FROM GEOPHONE	ELEV. AT GEO.	DEPTH (FEET)	VELOCITY FT./SEC.	REMARKS
S-1	11 Jan.	See Plan	100	1178	0-9	1050	
					9-36	4750	
S-2	11 Jan.	See Plan	120	1178	0-9	1050	
					47-31	4750	

NOTES:

1. Seismic lines are referenced to Geophone Location. Geophone Line direction is expressed in azimuth from the true north.
2. Seismic information is based on data obtained with the refraction seismograph Model MD-1, manufactured by the Geophysical Specialties Division of Seisfest, Inc. 2205 Lee St. Evanston, Ill. Impact was by an 8-pound hammer. Seismic data is intended to portray general characteristics of materials in the vicinity of the seismic line, but interpretations of the data shall consider limitations inherent in the equipment and method of explorations. In general, common materials have velocities lower than 4000 feet per second. Sound rock generally has seismic velocities higher than 6,000 ft. per sec. Classification of materials represented by intermediate velocities is not determinable and may range from common to rock materials.
3. Estimated depth of seismic penetration is in the order of $\frac{1}{3}$ the length of seismic line.

(1)

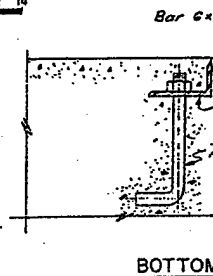
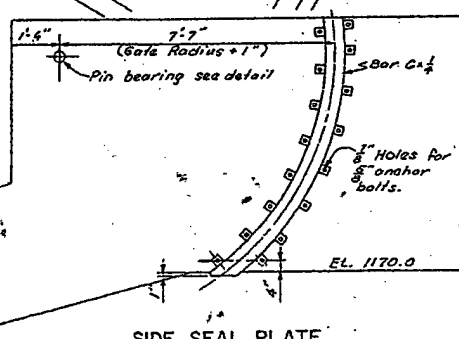
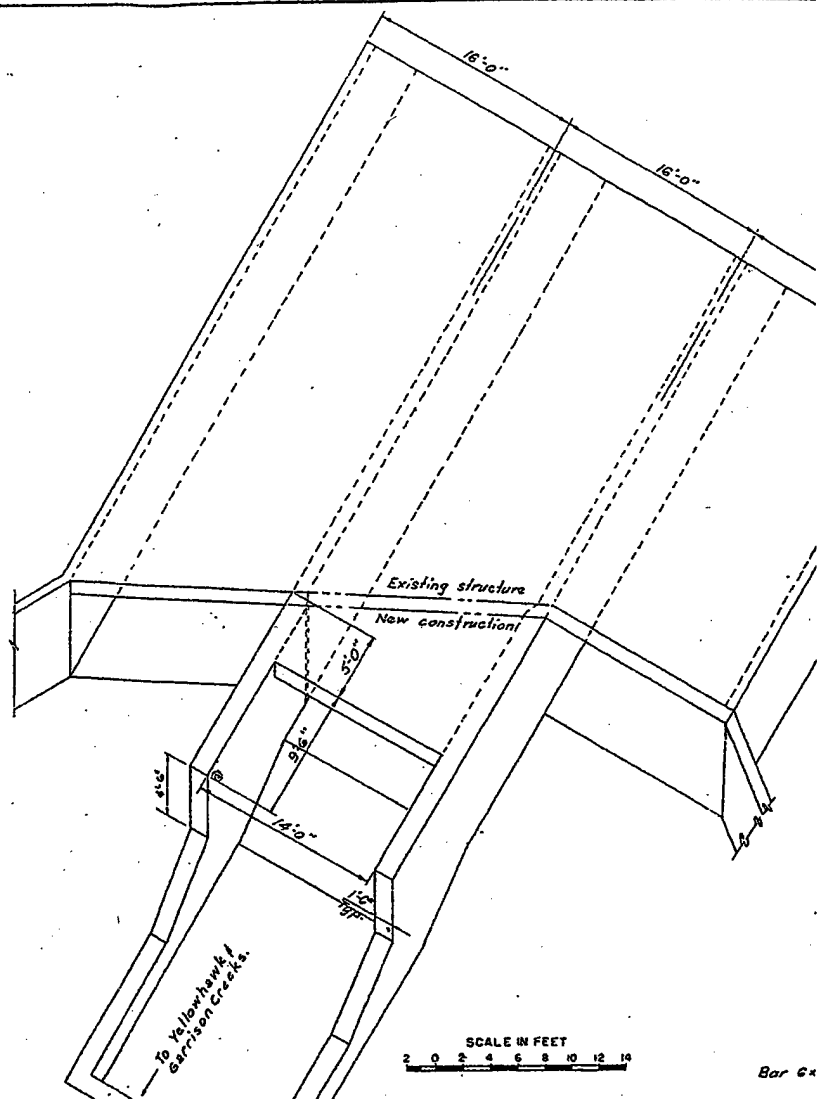
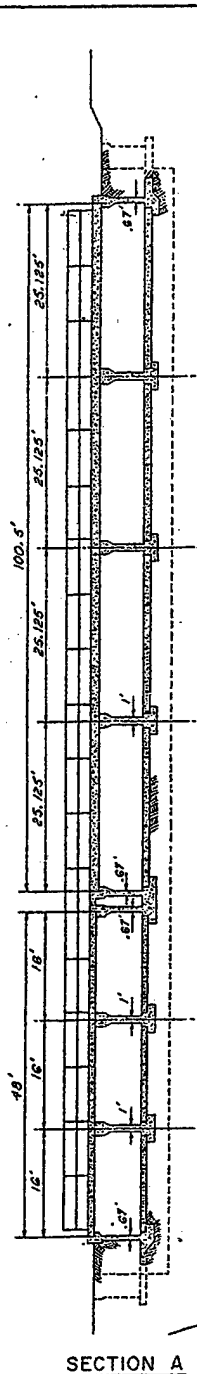
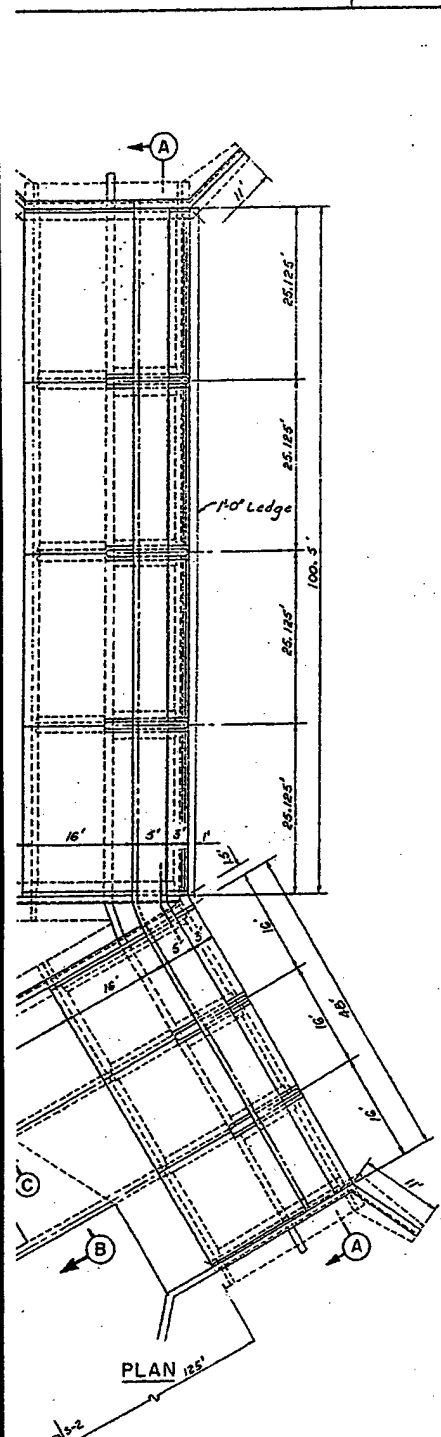

GARRISON DIVISION STRUCTURE

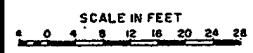

DEPTH (FEET)	VELOCITY FT./SEC.	REMARKS
7-9	1050	
13-34	4750	
73-84	14,000	
77-9	1050	
31	4750	
31	14,000	

Location. Geophone Line direction north.

Obtained with the refraction seismograph of the Geophysical Specialties Division of Spillfast, Inc. by use of a 10-pound hammer. Seismic data is intended for use in the vicinity of the seismic line, and is subject to the limitations inherent in the equipment and materials used. Materials have velocities lower than 4000 ft. per sec. and seismic velocities higher than 6,000 ft. per sec. Intermediate velocities are not determinable from this data.

Order of 1/3 the length of seismic line.

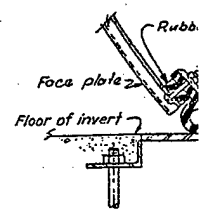
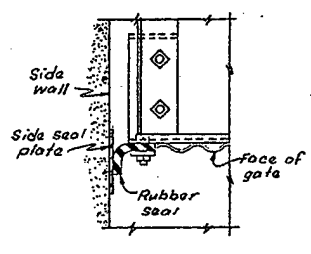
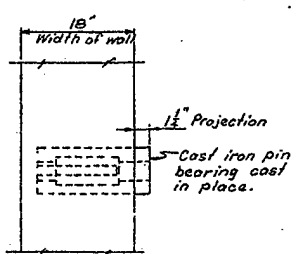

2

NOT TO SCALE

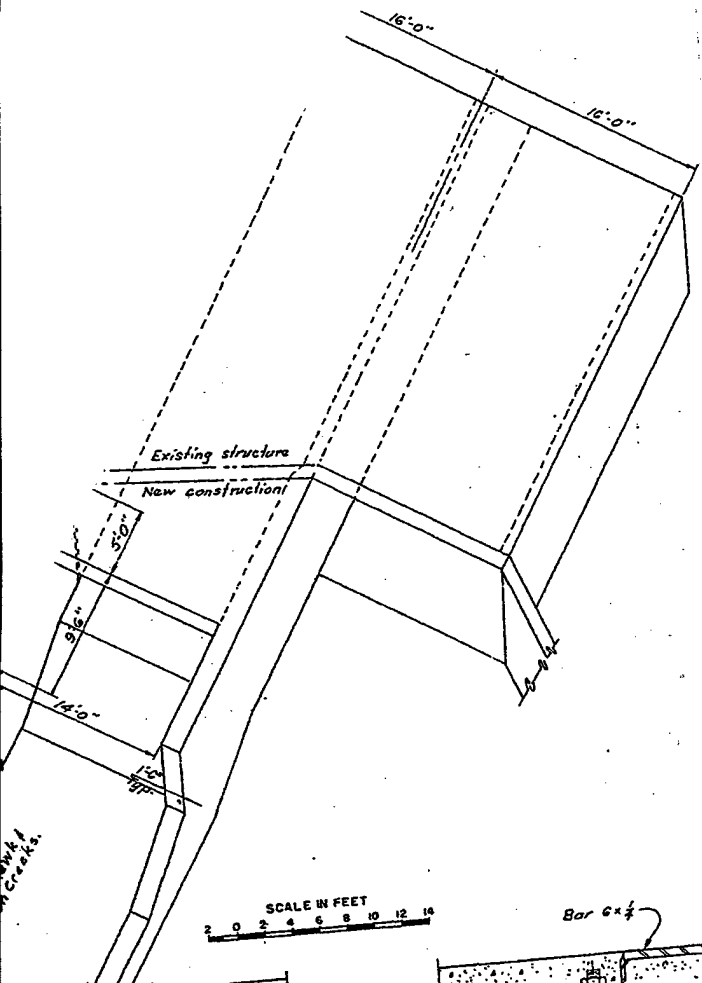

SCALE IN FEET
0 2 4 6 8 10 12 14

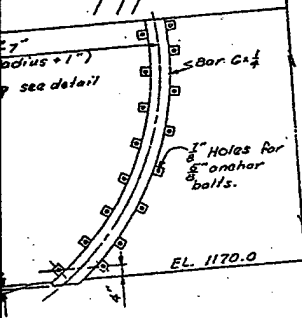

BOTTOM SEAL PLATE

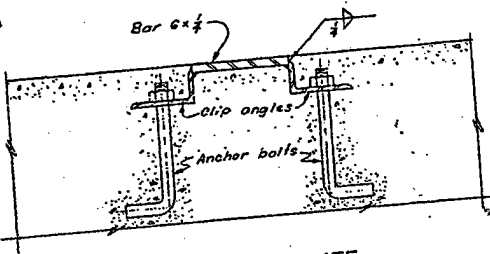

BOTTOM SEAL PLATE

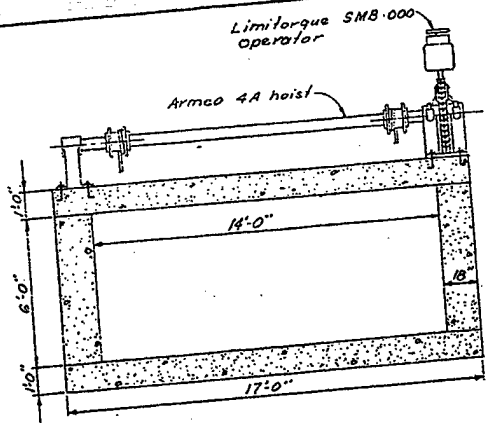

SECTION B

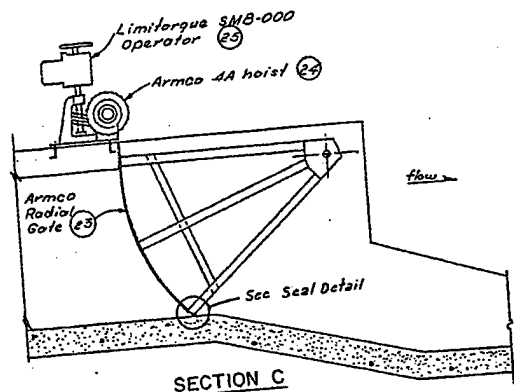

SECTION C

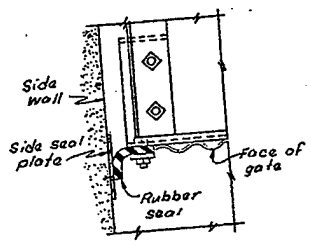

SIDE SEAL DETAIL

NOT TO SCALE

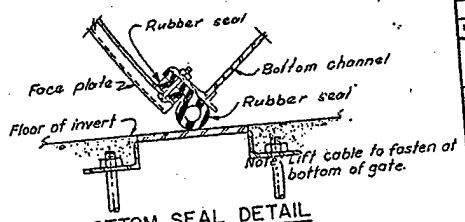

BOTTOM SEAL DETAIL

- NOTES:
1. Seals to have corrosion resistant bolts.
 2. Seals and seal plates shown on this sheet to be furnished with the radial gate.
 3. Seal plates to be corrosion resistant steel.

FOR INFORMATION ONLY

72 May 17	AS CONSTRUCTED	BY
77 Jul 08	Corrected existing structure	
77 Jun 08	Added notes	
REVISION	DATE	DESCRIPTION
U. S. ARMY ENGINEER DISTRICT WALLA WALLA, WASHINGTON MILL CREEK LAKE WALLA WALLA, WASHINGTON MILL CREEK DIVISION WORKS MECHANICAL DETAILS I		
DESIGNED: Lt. Olson	DATE 77 May 18	
DRAWN: C. H. Perry	APPROVED: <i>Richard M. Conwell</i> COLONEL, E. E. DISTRICT ENGINEER	
CHECKED: <i>R. E. Lusk</i>	SCALE AS SHOWN	INV. NO. 71-B-69
SUBMITTED: <i>R. E. Lusk</i>	45	FILE NO. MC-1-48/5
CHIEF DESIGN BRANCH	SHEET 2	
RECOMMENDED: <i>R. E. Lusk</i>		
CHIEF ENGINEERING DIVISION	VOL. NO.	Elms

3

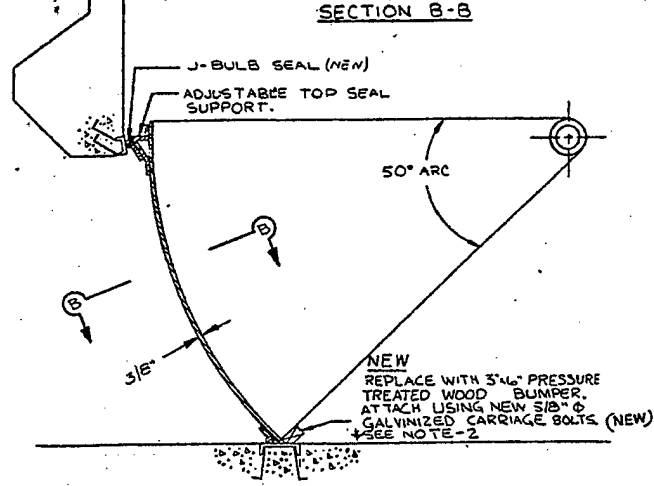
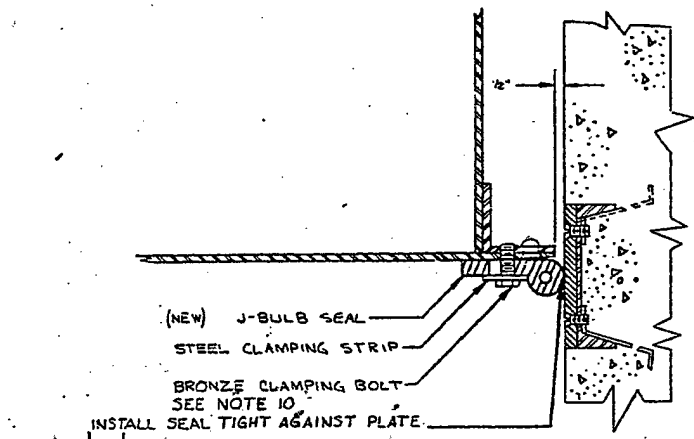
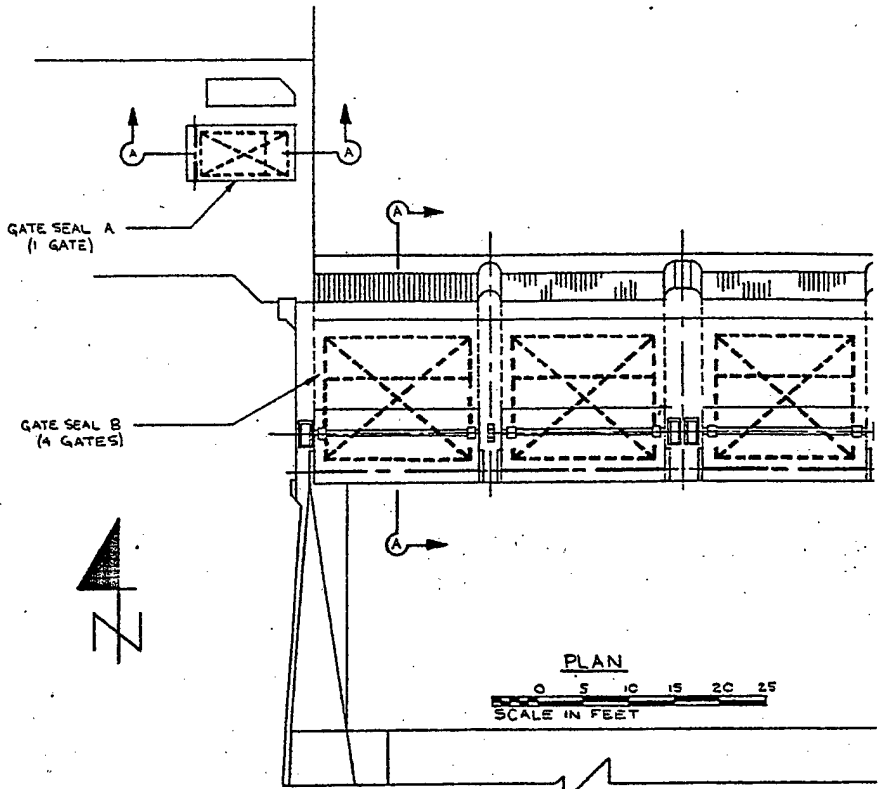

SECTION A-A
SEE TABLE FOR DIM. S

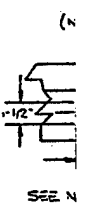

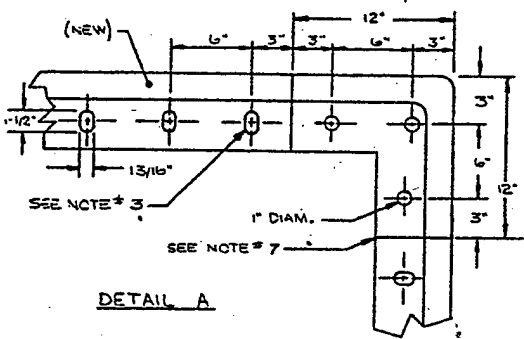
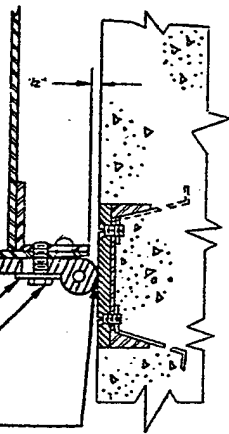
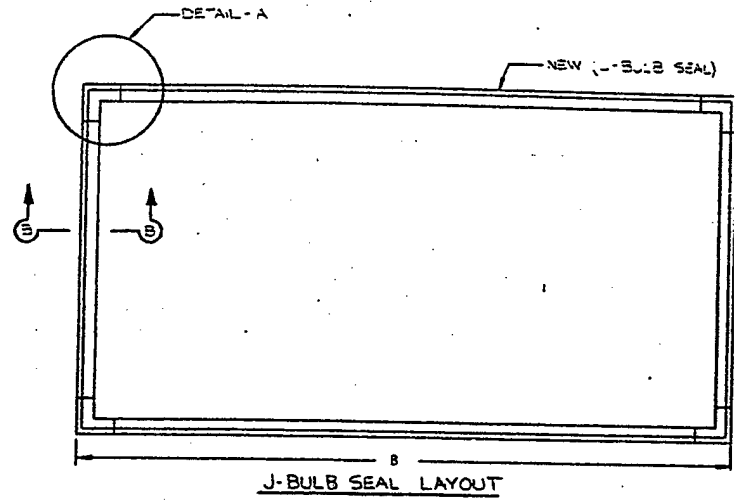
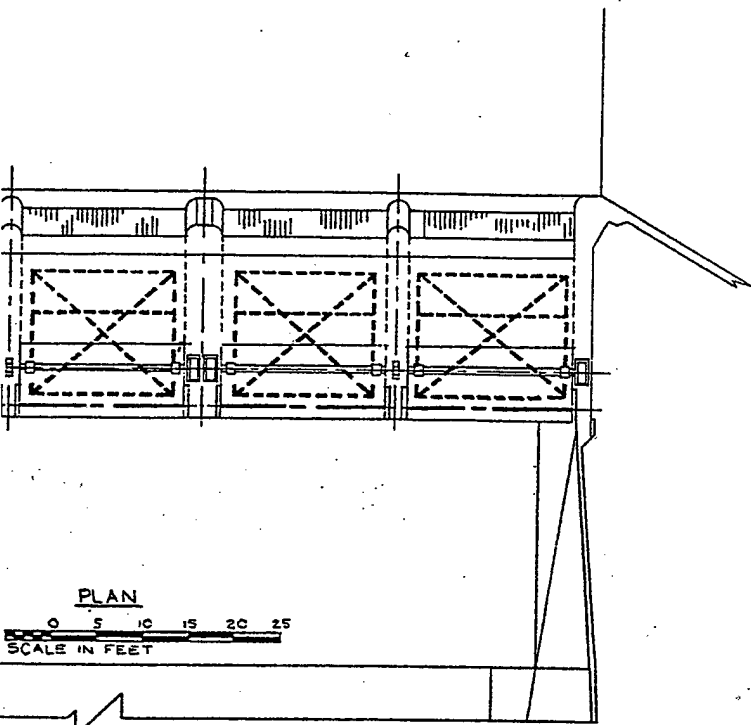

DIM	SEAL A 1 REQ'D	SEAL B 4 REQ'D
A	9'-10"	10'-0"
B	6'-0"	17'-0"

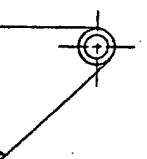

1 3/4" PRESSURE BUMPER
D NEW 5/8" Ø ARRIAGE BOLTS (NEW)

2

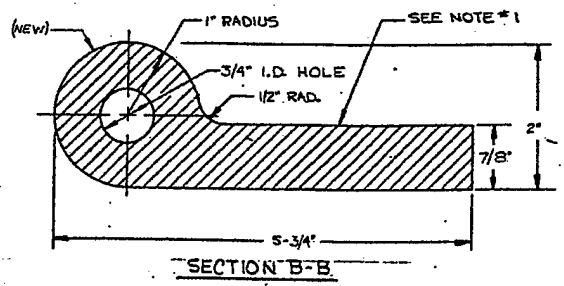

NOTES

1. J-BULB SEAL MATERIAL SHALL CONFORM TO ASTM D-2000-44B2S B1820.
2. CONTRACTOR TO VERIFY NUMBER AND SIZE OF BOLTS, AND LENGTH OF BUMPER.
3. PUNCH HOLES IN SEAL TO MATCH THE FIELD TOLERANCE OF CLAMPING BOLTS.
4. VERIFY AS-BUILT DIMENSIONS IN FIELD BEFORE TRIMMING J-SEAL TO LENGTH.
5. SEE SHEET NO. 1 FOR KEY PLANS & REF. DWGS.
6. ALL ITEMS ARE EXISTING UNLESS INDICATED "NEW".
7. BOND CORNER PIECES TO EDGE PIECES W/EPDXY TYPE 3M SCOTCHWELD 3214 BA GRAY SCLFF RUBBER CLEAN WITH METHYL ET-HYL KETONE PRIOR TO JOINT BOND APPLICATION.
8. REMOVE SILT SEDIMENT AS REQ'D FOR SATISFACTORY INSTALLATION & INSPECTION OF SEALS.
9. WOOD BUMPER TO BE 3"x6" DOUGLAS FIR, S4S, NO. 1 STRUCTURAL, WCLB GRADE. PRESSURE TREATMENT TO BE AWPB L44 OR L55.
10. REPLACE MISSING OR DAMAGED CLAMPING BOLTS WITH BRONZE, GALVANIZED STEEL, CADMIUM PLATED OR STAINLESS STEEL BOLTS.

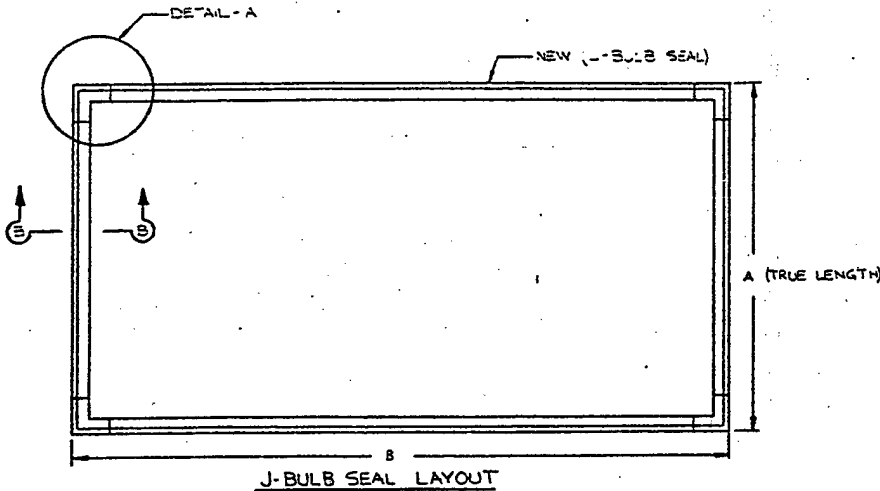

DIM	SEAL A 1 REQ'D	SEAL B 4 REQ'D
A	9'-10"	10'-0"
B	6'-0"	17'-6"

FOR INFORMATION ONLY

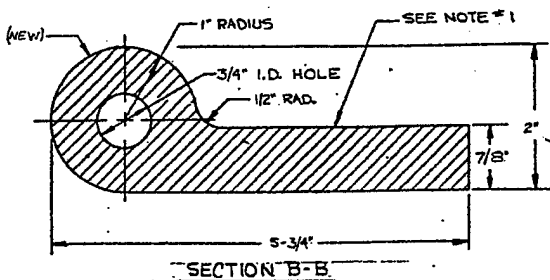

3

REVISION	DATE	DESCRIPTION	BY
A	21 Aug 83	As Constructed Misc. rev's.	DR
RICHARD ENGINEERING		CEC	U.S. ARMY ENGINEER DISTRICT
1204 140TH AVE, RICHLAND, WA 99222		WALLA WALLA, WASHINGTON	
MILL CREEK FLOOD CONTROL PROJECT			
WALLA WALLA, WASHINGTON			
MILL CREEK REHABILITATION			
INTAKE CANAL			
GATE SEAL REPLACEMENT			
DESIGNED: <i>[Signature]</i>	APPROVED: DATE 83 Jul 22		
DRAWN: <i>[Signature]</i>	SCALE AS SHOWN		
CHECKED: <i>[Signature]</i>	INSTR. NO. 83-B-78		
REVIEWED: <i>[Signature]</i>	FILE NO.		
RECOMMENDED: <i>[Signature]</i>	50		
DATE: 83 Jul 22	MC-1-78/4		

SEAL CLAMP BARS

STR. ST.
MAKE 4 1-5'-0" MK-21-Scals
4 1-8'-0" MK-22-7/16



PIN
CR STEEL
MAKE 4 MK

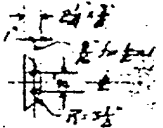

KEEPER
STR. ST.
MAKE 4 MK

10-11 1/2 Rad. to inside of saw plate

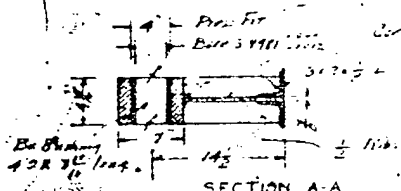

SECTION A-A

15/16 hole except at total
height 3/4

3/4 Ring Fillets

ARM
ST. & BRONZE

REVERSE SIDE

Copies Furnished to DTIC
Reproduced From
Bound Originals

Reproduced From
Best Available Copy



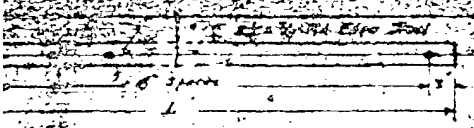

SEAL CLAMP BARS

STR. ST.

MAKE 4 L. 5'-0" MK-21 - 4/16"
 4 L. 8'-0" MK-22 - 7/16" dia. - 1/2" thick

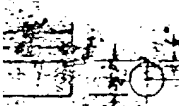

PIN
 CR. STEEL
 MAKE 4 MK.

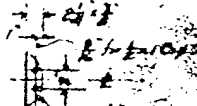

KEEPER
 STR. ST.
 MAKE 4 MK.

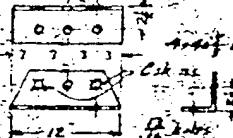

LIFTING ANGLE
 STR. ST.
 MAKE 4 MK.

10 1/2" Rad. to inside of seam plate

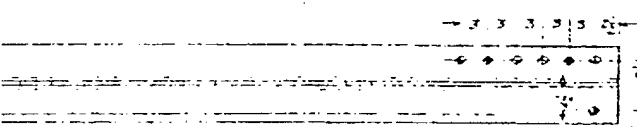

1/2" dia. holes in side
 4" apart

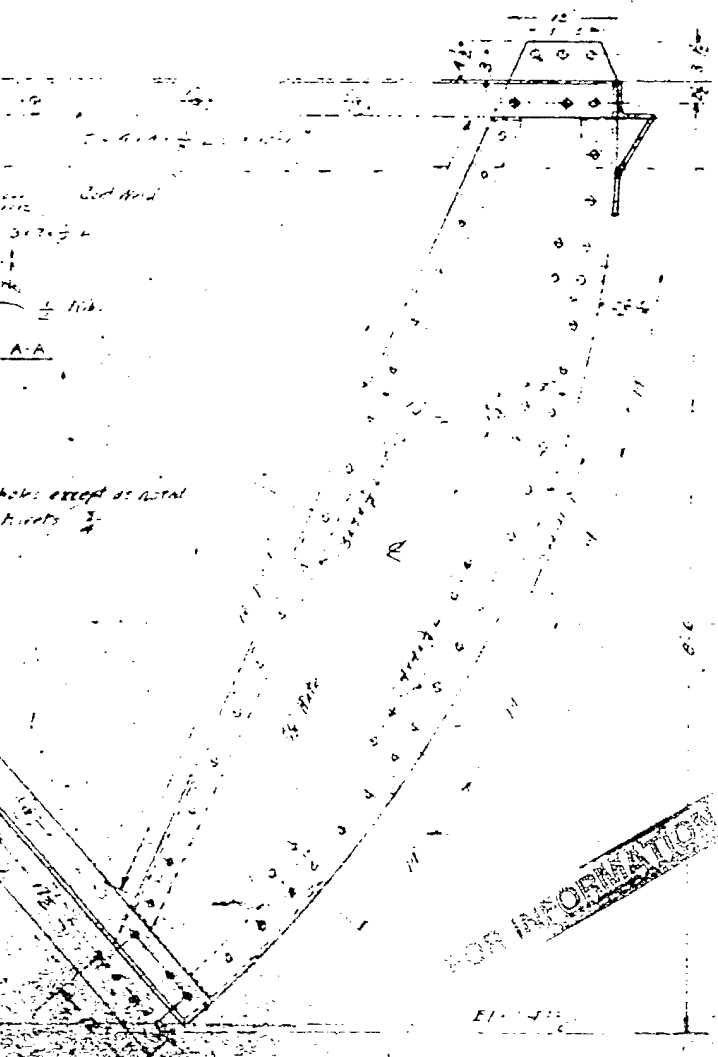

holes except as noted
 here 3/4"

A-A

FOR INFORMATION ONLY

DEVELOPED VIEW

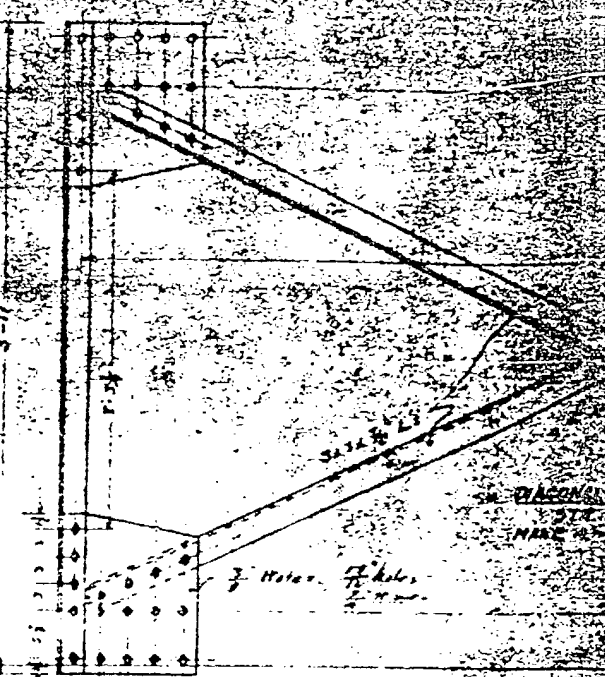

SEAM PLATE
 STR. ST.
 MAKE 4 MK.

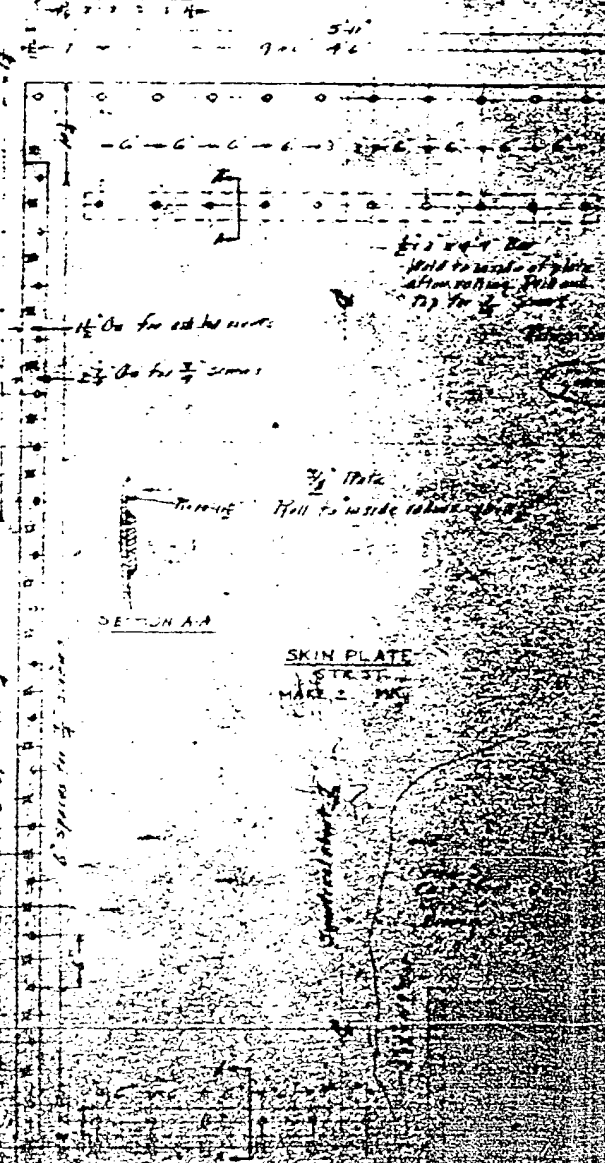

Weld to inside of plate
 after rolling. Pin and
 top for 1/2" seam

SECTION A-A

SKIN PLATE
 STR. ST.
 MAKE 2 MK.

Length as developed
 6" space for 1/2" dia. hole
 6" space for 1/2" seam

3/4" Thick
 Roll to inside before welding

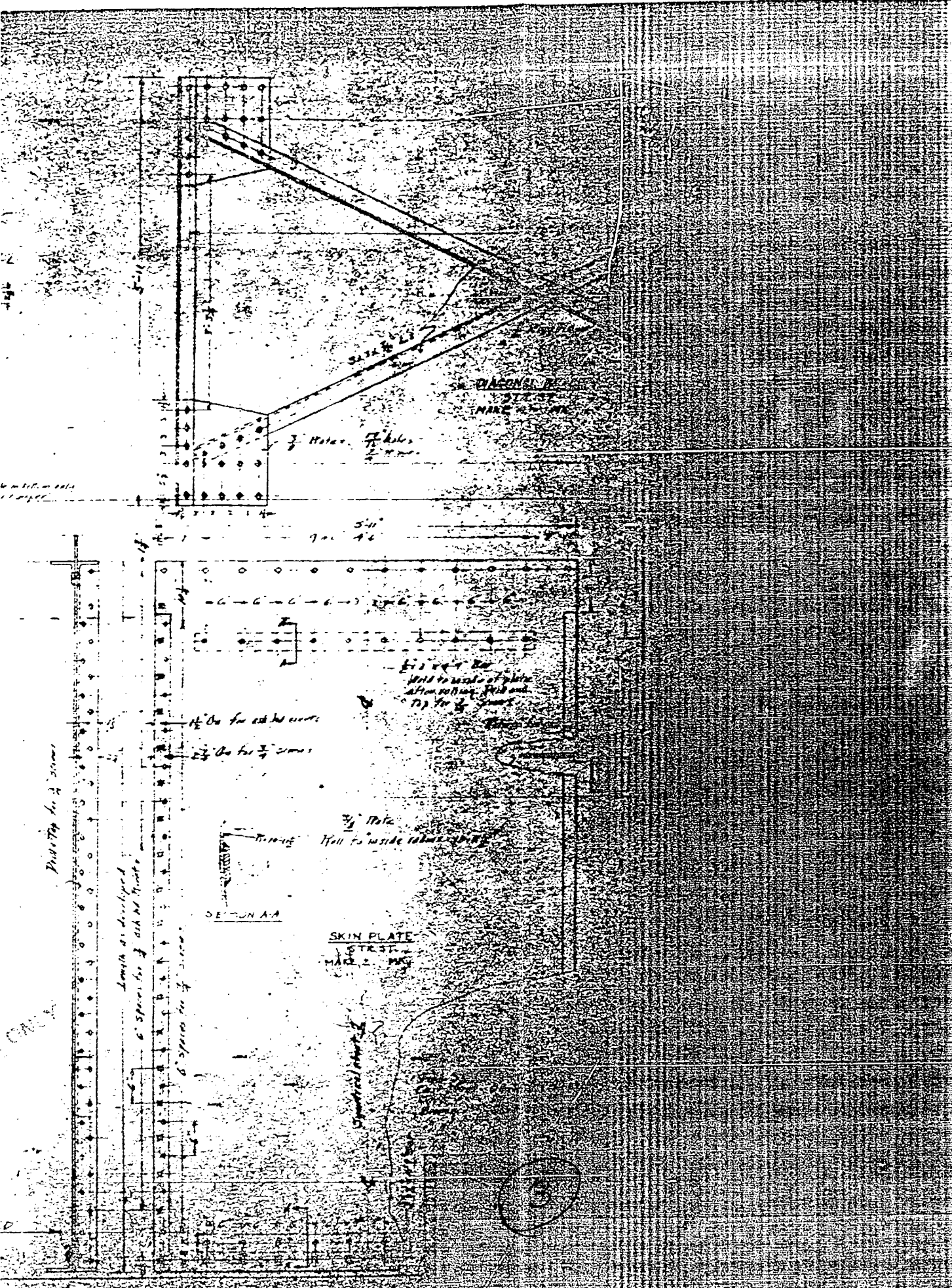

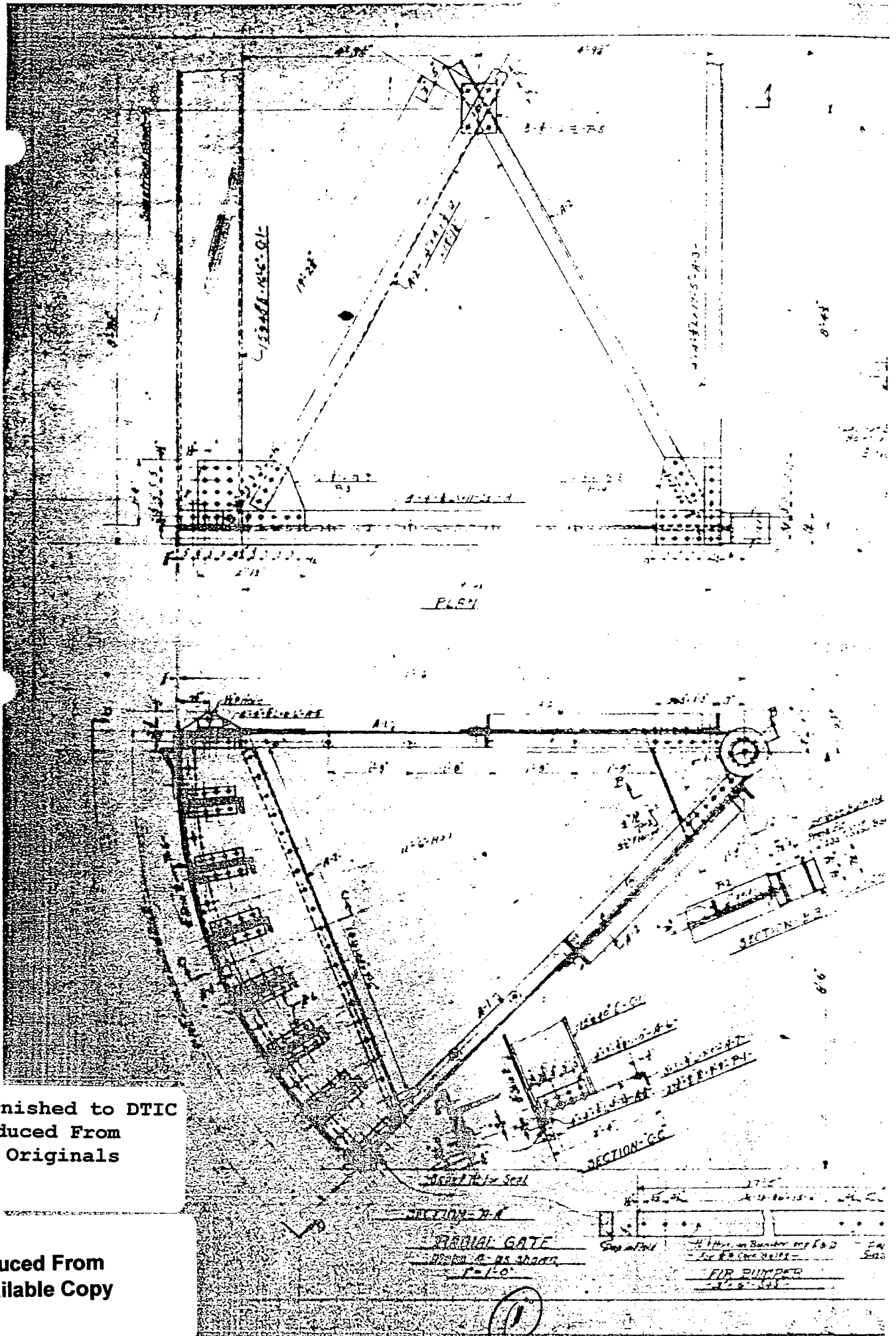

Copies Furnished to DTIC
 Reproduced From
 Bound Originals

Reproduced From
 Best Available Copy

TRIAL GATE

SECTION-BA

SECTION-CC

FIR BUMPER



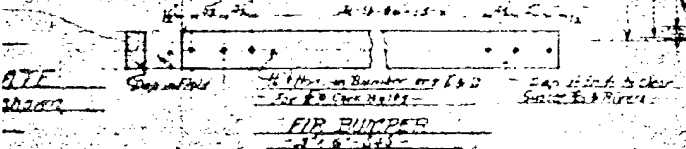
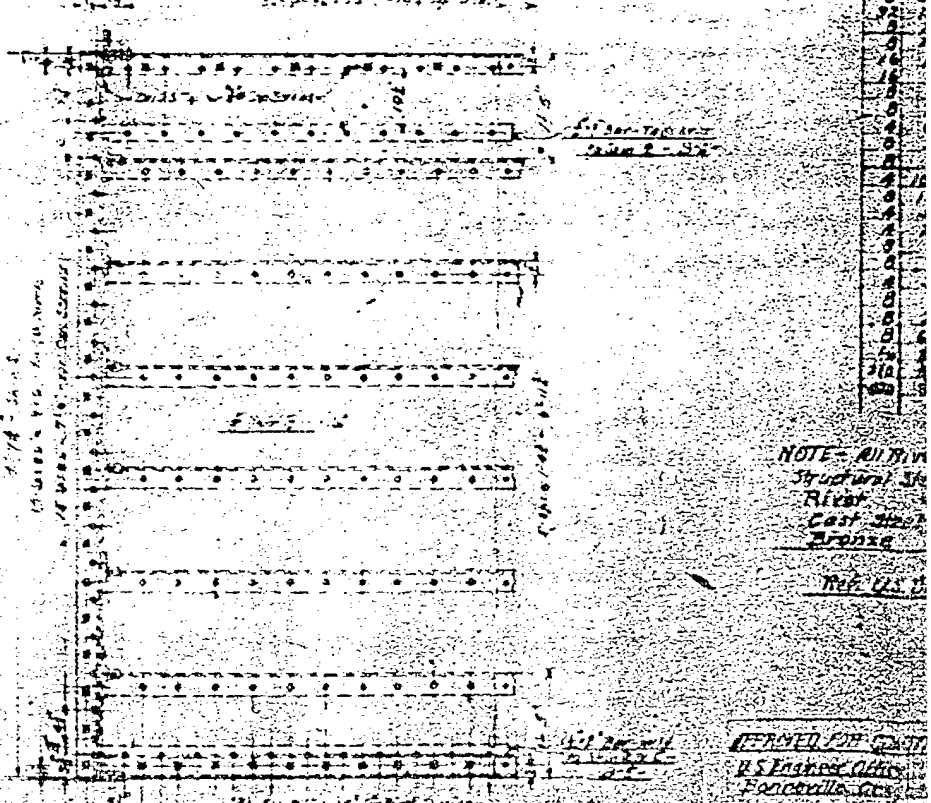
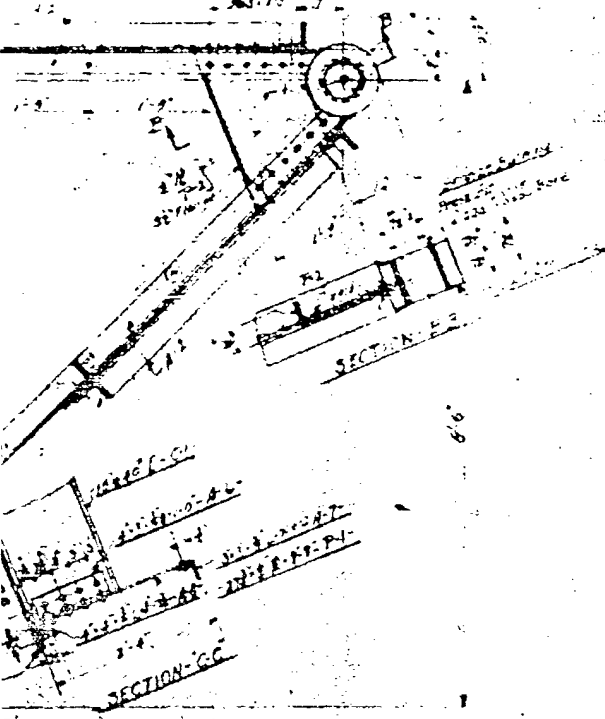
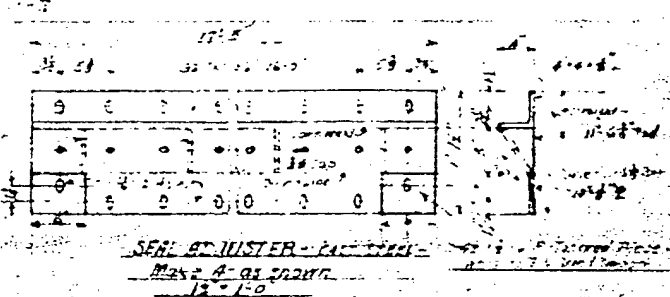
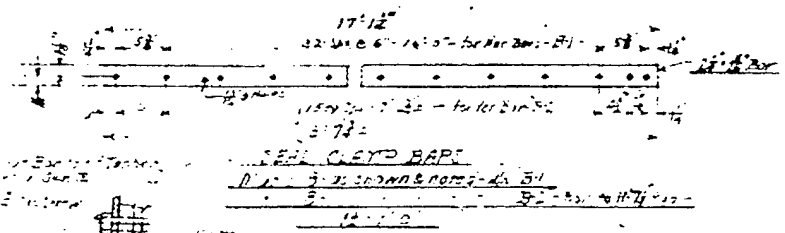
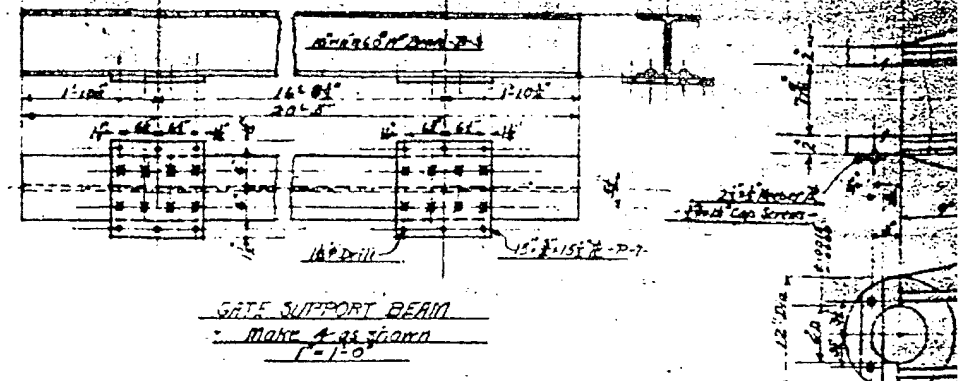
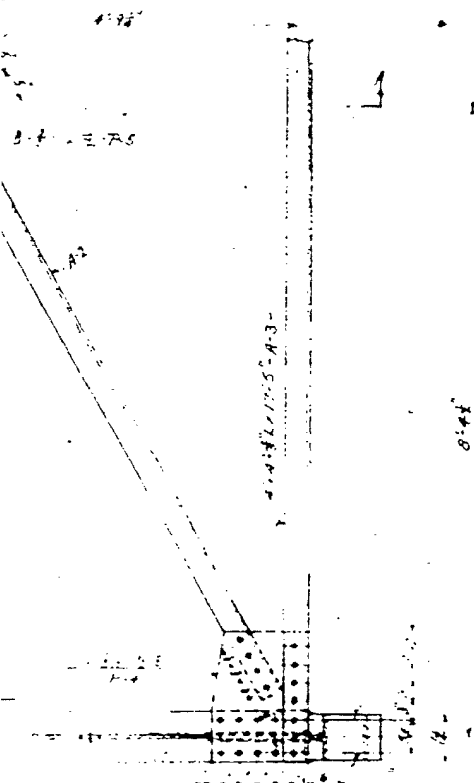

NOTE - All Rivets
 Structural Steel
 River
 Cast Iron
 Bronze

APPROVED FOR CONSTRUCTION
 U.S. Engineer Office
 Fort Belvoir, Ill.
 By: J. R. ...
 Date: Oct. 1917

(2)

FOR INFORMATION ONLY

4 - 8 x 18 GATES

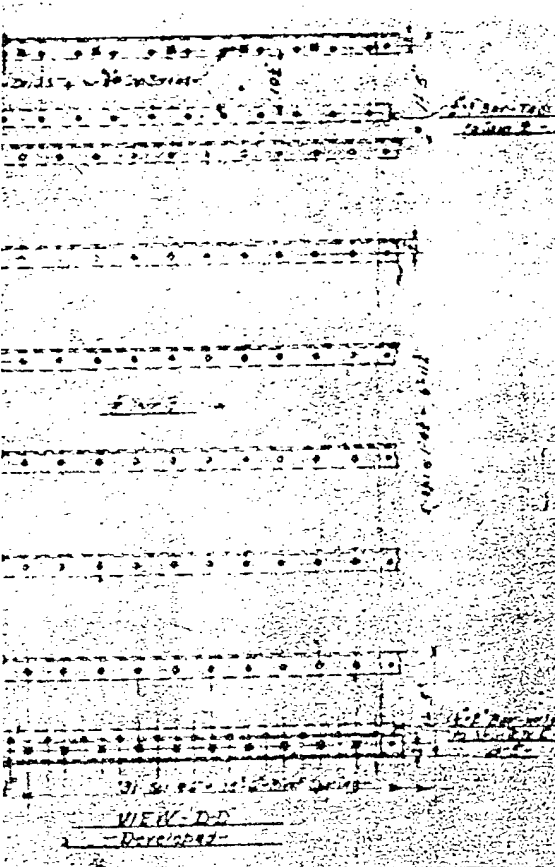
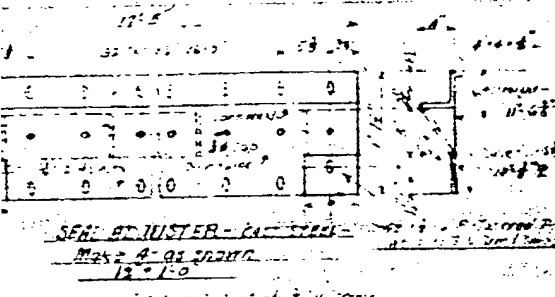
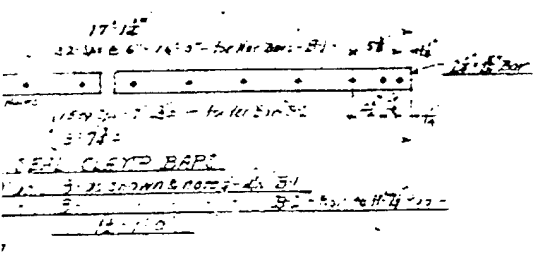
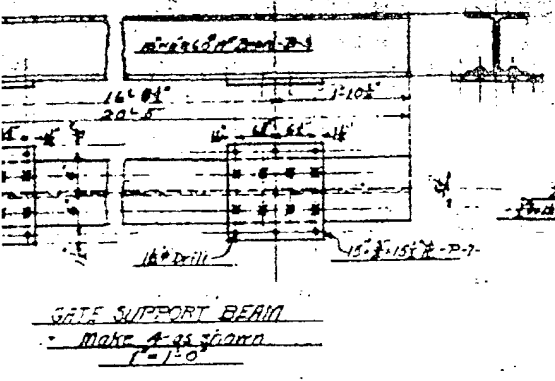

No.	Material	Description
10	10 x 10	CR Steel
12	12 x 12	CR Steel
14	14 x 14	CR Steel
16	16 x 16	CR Steel
18	18 x 18	CR Steel
20	20 x 20	CR Steel
22	22 x 22	CR Steel
24	24 x 24	CR Steel
26	26 x 26	CR Steel
28	28 x 28	CR Steel
30	30 x 30	CR Steel
32	32 x 32	CR Steel
34	34 x 34	CR Steel
36	36 x 36	CR Steel
38	38 x 38	CR Steel
40	40 x 40	CR Steel
42	42 x 42	CR Steel
44	44 x 44	CR Steel
46	46 x 46	CR Steel
48	48 x 48	CR Steel
50	50 x 50	CR Steel
52	52 x 52	CR Steel
54	54 x 54	CR Steel
56	56 x 56	CR Steel
58	58 x 58	CR Steel
60	60 x 60	CR Steel
62	62 x 62	CR Steel
64	64 x 64	CR Steel
66	66 x 66	CR Steel
68	68 x 68	CR Steel
70	70 x 70	CR Steel
72	72 x 72	CR Steel
74	74 x 74	CR Steel
76	76 x 76	CR Steel
78	78 x 78	CR Steel
80	80 x 80	CR Steel
82	82 x 82	CR Steel
84	84 x 84	CR Steel
86	86 x 86	CR Steel
88	88 x 88	CR Steel
90	90 x 90	CR Steel
92	92 x 92	CR Steel
94	94 x 94	CR Steel
96	96 x 96	CR Steel
98	98 x 98	CR Steel
100	100 x 100	CR Steel

NOTE - All rivets are Structural Steel Rivets
 Rivet
 Cast Steel
 Bronze

Ref. U.S. Gov. Pat. 1,234,567

APPROVED FOR CONSTRUCTION
 U.S. Engineer Office
 Fanninville, Ga.
 BY: [Signature]
 Date: Oct. 1912



FOR INFORMATION ONLY