

Award Number: DAMD17-00-1-0602

TITLE: An Improved Bio-Optical Method for Tumor Detection and Classification

PRINCIPAL INVESTIGATOR: James G. Leatham

CONTRACTING ORGANIZATION: Applied Photonics
Encinitas, California 92024

REPORT DATE: October 2002

TYPE OF REPORT: Final

PREPARED FOR: U.S. Army Medical Research and Materiel Command
Fort Detrick, Maryland 21702-5012

DISTRIBUTION STATEMENT: Approved for Public Release;
Distribution Unlimited

The views, opinions and/or findings contained in this report are those of the author(s) and should not be construed as an official Department of the Army position, policy or decision unless so designated by other documentation.

20030317 110

REPORT DOCUMENTATION PAGEForm Approved
OMB No. 074-0188

Public reporting burden for this collection of information is estimated to average 1 hour per response, including the time for reviewing instructions, searching existing data sources, gathering and maintaining the data needed, and completing and reviewing this collection of information. Send comments regarding this burden estimate or any other aspect of this collection of information, including suggestions for reducing this burden to Washington Headquarters Services, Directorate for Information Operations and Reports, 1215 Jefferson Davis Highway, Suite 1204, Arlington, VA 22202-4302, and to the Office of Management and Budget, Paperwork Reduction Project (0704-0188), Washington, DC 20503

1. AGENCY USE ONLY (Leave blank)		2. REPORT DATE October 2002	3. REPORT TYPE AND DATES COVERED Final (15 Sep 00 - 14 Sep 02)	
4. TITLE AND SUBTITLE An Improved Bio-Optical Method for Tumor Detection and Classification			5. FUNDING NUMBERS DAMD17-00-1-0602	
6. AUTHOR(S) James G. Leatham				
7. PERFORMING ORGANIZATION NAME(S) AND ADDRESS(ES) Applied Photonics Encinitas, California 92024 E-Mail: jim@applied-photonics.com			8. PERFORMING ORGANIZATION REPORT NUMBER	
9. SPONSORING / MONITORING AGENCY NAME(S) AND ADDRESS(ES) U.S. Army Medical Research and Materiel Command Fort Detrick, Maryland 21702-5012			10. SPONSORING / MONITORING AGENCY REPORT NUMBER	
11. SUPPLEMENTARY NOTES Report contains color.				
12a. DISTRIBUTION / AVAILABILITY STATEMENT Original contains color plates. All DTIC reproductions will be in black and white.			12b. DISTRIBUTION CODE	
13. ABSTRACT (Maximum 200 Words) Optical approaches to breast cancer (BC) detection show promise over conventional methods because they have potential to work in the denser tissue of younger patients and because they do not use ionizing radiation which has been shown to induce cancer in some patients. Three technologies will be combined in this effort. (a) Optical probing, using controlled light at specific wavelengths, is becoming a respected approach to cancer tumor detection. A much-published RADAR-based method known as frequency-domain photon migration (FDPM) gives very high sensitivity. (b) "Spectral fingerprint" analysis of fluorescence emission is the basis for cancer and precancer classification affecting surface cells. This has been shown for cervical and lung cancers. (c) Reading images, such as x-ray films, allows the tumor to stand out relative to the "expected" complex image of the breast. An optical hardware system was envisioned and preliminary testing performed. Hardware was to be based on using technically similar systems used in unrelated industrial applications to make hardware development affordable. Specific systems were identified. Ultimately, collaborators could not be found to modify their systems, and system development proved to be prohibitively costly. Discussions with other researchers has provided a voice for this approach within the community, paving the way for valuable contributions to BC detection.				
14. SUBJECT TERMS Spectral, fluorescence, frequency-domain, optical, breast cancer			15. NUMBER OF PAGES 15	
			16. PRICE CODE	
17. SECURITY CLASSIFICATION OF REPORT Unclassified	18. SECURITY CLASSIFICATION OF THIS PAGE Unclassified	19. SECURITY CLASSIFICATION OF ABSTRACT Unclassified	20. LIMITATION OF ABSTRACT Unlimited	

Table of Contents

Cover.....	1
SF 298.....	2
Table of Contents.....	3
Introduction.....	4
Body.....	4
Key Research Accomplishments.....	6
Reportable Outcomes.....	6
Conclusions.....	7
References.....	7
Appendices.....	8

INTRODUCTION:

Optical approaches to breast cancer detection show promise over conventional methods because they have potential to work in the denser tissue of younger patients and because they do not use ionizing radiation which has been shown to induce cancer in some patients. Early diagnosis of the disease is key to successful treatment. Three technologies will be combined in this effort. (a) Optical probing, using controlled light at specific wavelengths, is becoming a respected approach to cancer tumor detection. A much-published RADAR-based method known as frequency-domain photon migration (FDPM) gives very high sensitivity. (b) "Spectral fingerprint" analysis of fluorescence emission is the basis for cancer and precancer classification affecting surface cells. This has been shown for cervical and lung cancers. (c) Reading images, such as x-ray films, allows the tumor to stand out relative to the "expected" complex image of the breast.

An optical hardware system will be built up and used to assess feasibility. Parts selection and overall design are based on a system analysis and trade-off analyses to determine the best approach. Variation in spectral signatures between benign and cancerous tissues will validate this concept.

BODY:

This is a concept grant whose purpose is to build a hardware system to test a new hypothesis. The allocated funding is insufficient, so a portion of the effort is to leverage the grant money to develop the system with internal or collaborative efforts. The statement of work for this research effort is necessarily broad and abbreviated, due to the space limitations imposed on the proposal.

The statement of work has been fleshed out by Applied Photonics in a program plan to include a literature search portion followed by a system design and design of system tests. This is followed by system build-up and test.

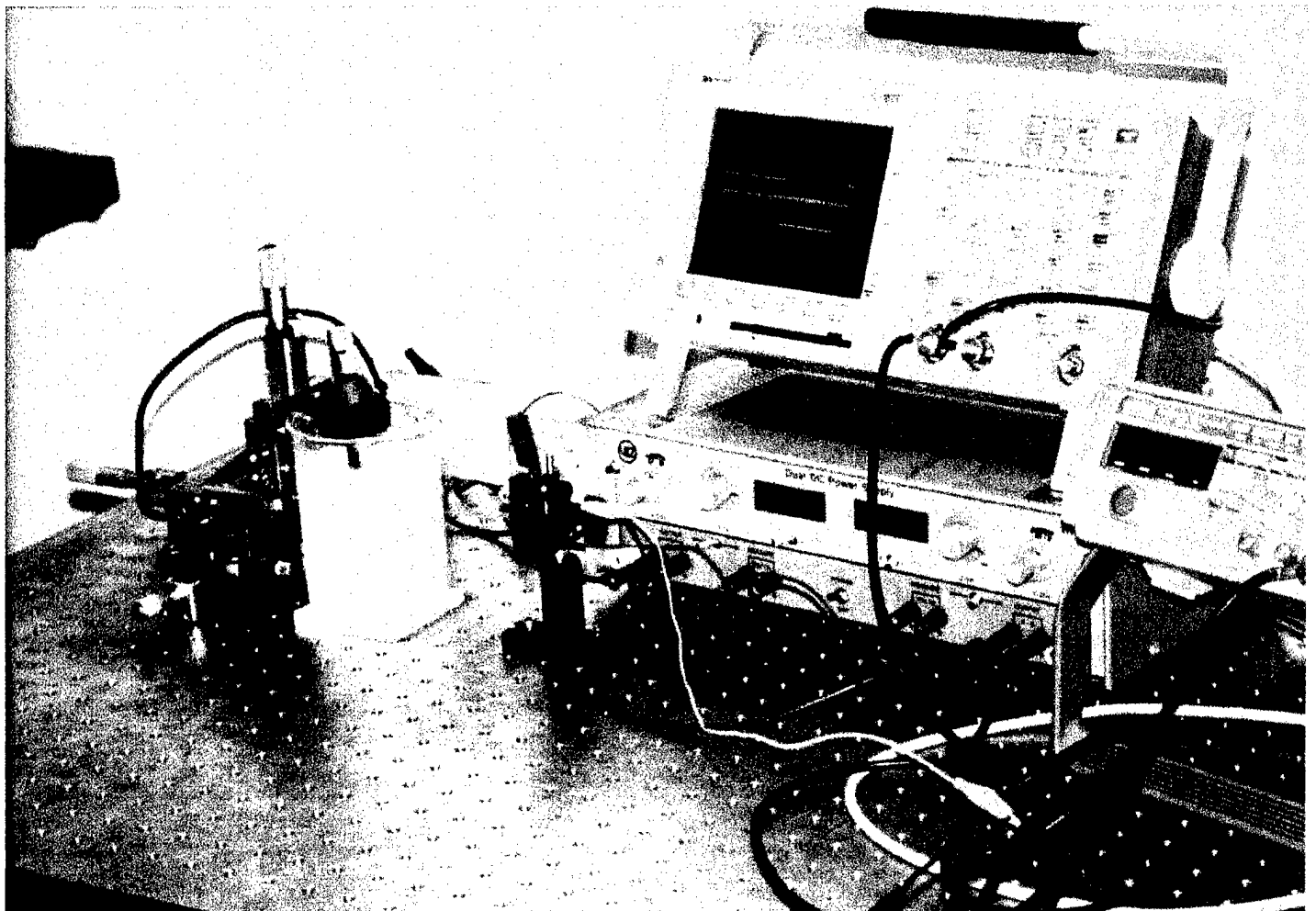

Figure 1. This diode-laser based test was to gather data to develop the system computer model.

The effort began with literature/patent search, test design, and collaborative efforts. The collaborative efforts included preliminary discussions with Sandia National Labs regarding technology transfer of their imaging LIDAR (Light detection and Ranging) technology, and discussions with a synchronous system developer regarding modifications to boards to have relatively low-cost accessibility to required RF (radio frequency) circuits. An outcrop of this effort, though not financially supported by this effort, is the development of collaborative efforts with the Johnson Research Foundation at the University of Pennsylvania and the Cancer Center at the University of California, San Diego (an NIH accredited cancer research center), including spearheading clinical trials for a continuouswave, more limited application system developed at the University of Pennsylvania (IRB Submittal protocol attached in the appendix).

The grant period was extended one year to allow for hardware buildup, since these collaborative initiatives have expanded the scope of the overall Applied Photonics efforts and increased the project's timeline.

A preliminary computer model was made of the system, and tests designed to verify model parameters as a precursor to designing the full system. The test configurations is shown in the photograph of figure 1. A frequency generator is used to modulate a diode laser at a wavelength of 635 nm. A purely absorbing medium of 1 cm X 1 cm X 1 cm is placed in an 8 cm diameter cylindrical container filled with a scattering solution. The absorbing medium is India ink diluted to various contrasts with water. The scattering medium is whole milk diluted with water. Attenuation coefficients were measured by measuring the unscattered transmission through the beaker, normalized with a beaker of distilled water. A 2 mm aperture was placed over the detector to measure only unscattered light, and the attenuation coefficient determined in the normal way, using Beer's law. The intent was to perform testing not only at reduced scattering coefficients representing normal breast tissue (i.e. $\sim 0.9/\text{mm}$), but also in a range to help determine system parameters such as contrast transfer function and signal to noise ratio (CTF, SNR).

A Hamamatsu avalanche photodiode reverse-biased at 100 V was placed in an orthogonal path to the light to

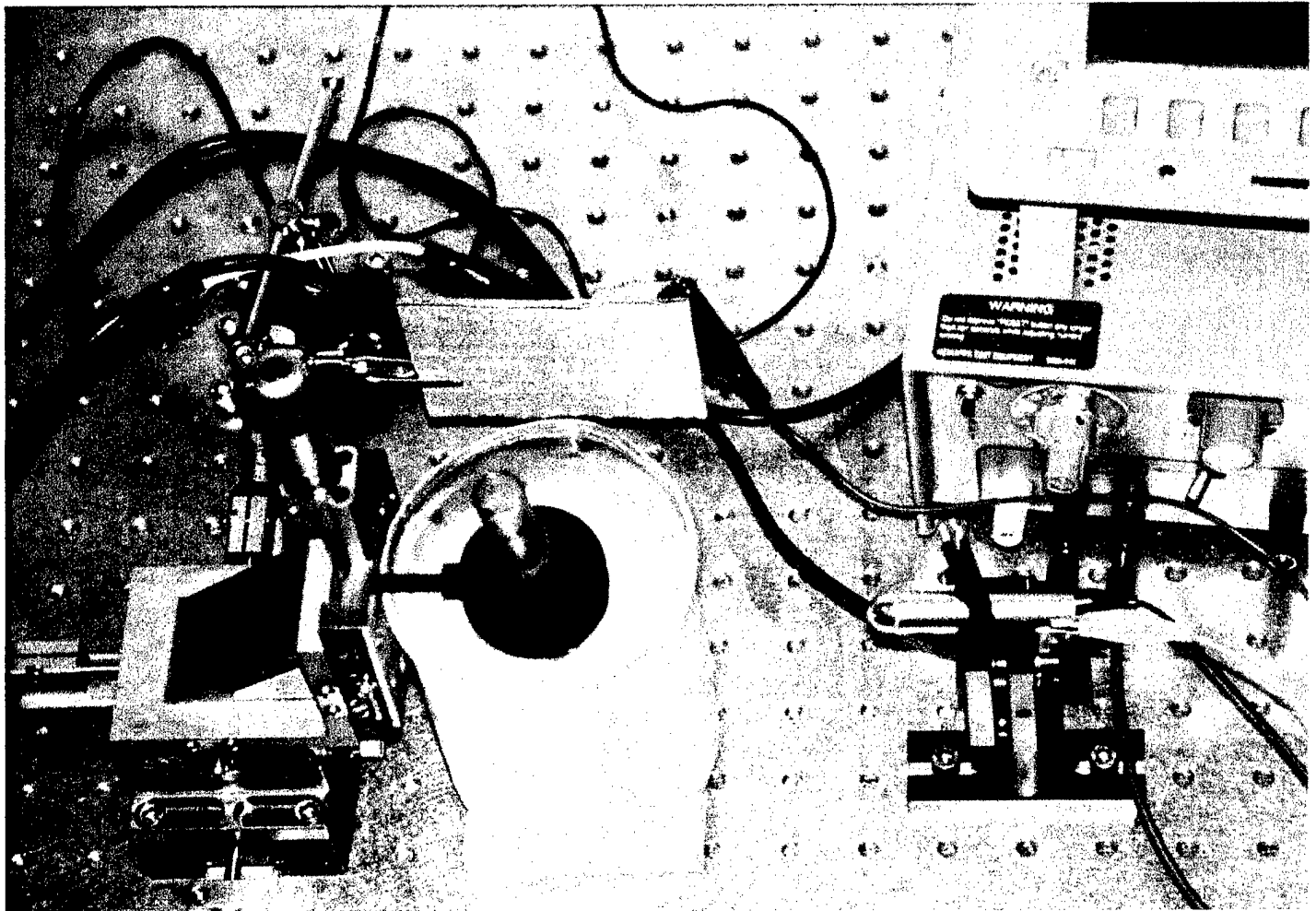

Figure 2. The test layout uses an orthogonal geometry to minimize effects of forward and backscatter signal enhancement.

minimize the proximal and distal effects of the phase function shape on the received light measurements (see figure 2). Using this test configuration and collecting data with a 500 MHz (analog vertical bandwidth), 5 Gs/sec digitizing oscilloscope, we were measuring the CTF and SNR of the test configuration as the reduced scattering length and the absorption coefficient were varied. This test confirmed that phase noise jitter has to be kept very low to gather any meaningful data. The data for even the lowest reduced scattering coefficient and highest absorption coefficient was below the detectable noise level.

The effort to build up the hardware followed 4 distinct avenues. We developed a preliminary set of specifications and attempted to price out a design from scratch. This avenue was prohibitively expensive. We vigorously pursued trying to obtain designs for the circuits used at Sandia for the imaging LIDAR system on the theory that modifying existing circuits benefits from the learning curve of the original design, and may be achievable on a reduced budget. Eventually, it became evident that as a government lab, they compelled to cooperate fully with appearing to attempt to transfer technology to industry, whether or not they really intended to, in order to comply with federal rules. After much discussion and liaison efforts, we abandoned that avenue. We also pursued trying to adapt an industrial circuit developed by private industry. After September 11, 2001, the mix of work and the level of priorities shifted within many small businesses. We found that this avenue was not open to us, either. Finally, we attempted to work with the manufacturer of a potential light source, who had developed a modulated source at 400 MHz by adapting a cell phone circuit to drive their lamps. The financial incentive we could offer was too little to induce them to help. In other words, with limited resources, they are unwilling to divert any from their main-line industrial lighting business to develop a single-use device.

As a result, after extensive efforts to build up, borrow, or adapt appropriate hardware to conduct the testing, we were unable to build a prototype. The scope envisioned for this effort ultimately was too great for the funding/resources applied.

During the conduct of this effort, however, we developed stronger relationships and recognition as a contributor by members of this community. It is a very tight community, so this result alone is invaluable. We still firmly believe in the value of this approach and feel we will be able to leverage the relationships and knowledge gained through this project into a valuable contribution to early detection of breast cancer. As a result of this grant, the approaches and methods espoused here have found a voice and gained entrance to the larger stage of community exposure.

KEY RESEARCH ACCOMPLISHMENTS:

- Initiated collaborative relationship with Prof. Britton Chance of the Johnson Research Foundation, University of Pennsylvania for collaborating on clinical trials and possibly collaborative development of an optical breast cancer detection device.
- Developed collaboration with the University of California, San Diego (UCSD) Cancer Research Center to conduct clinical trials on a hand-held optical breast cancer detection device.
- Conducted Literature Search
- Conducted Test Planning
- Developed alliances and collaborations with industry partner who can provide RF drive circuit.

REPORTABLE OUTCOMES:

- Basis of NIH SBIR Proposal.
- Resulted in discussions regarding inclusion in a collaborative, multi-site NIH effort to prove out methods of optical breast cancer detection.
- Resulted in collaboration with Prof. Britton Chance of the Johnson Research Foundation, University of Pennsylvania for collaborating on clinical trials and possibly collaborative development of an optical breast cancer detection device.
- Resulted in collaboration with the University of California, San Diego (UCSD) Cancer Research Center to

- conduct clinical trials on a hand-held optical breast cancer detection device.
- Resulted in invitation to present invited talk: "Advances in Optical Based Imaging, the Breast Cancer Model" at the annual meeting of the American Osteopathic College of Physical Medicine and Rehabilitation, October 21-25, 2001.
- Resulted in invitation to present invited poster: "Recent Progress in Optical Fluorescence Detection of Tumors," Era Of Hope meeting on advances in Breast Cancer Research, Orlando, FL September 25-28, 2002.

CONCLUSIONS:

This effort was ultimately not able to develop the collaborative hardware development required to build hardware on such a relatively small budget. Though collaboration looked promising at the outset, the changing priorities and dynamics of potential collaborators ultimately did not support the hardware build. During the course of performing on this project, however, we have had opportunities open up as a direct result of the experience and training provided by this award. We have established a working relationship with a pre-eminent local cancer research center (UCSD) and with the pre-eminent academic laboratory (Prof. Britton Chance at the Johnson Research Foundation, University of Pennsylvania) in optical detection of breast cancer. We have had discussions with a member of the NIH working group on optical methods for breast cancer detection including an invitation to join the proposal effort for a multi-site, multi-disciplinary effort to develop specialized test hardware to prove out these methods. In addition, we have begun to establish credibility as evidenced by an invitation to present at the American Osteopathic College of Physical Medicine and Rehabilitation annual meeting. We will expand and continue these efforts which have been facilitated by this award.

REFERENCES:

N/A

APPENDICES:

Invited Speaker Program Page
IRB Protocol Submittal

Appendix: Wednesday, 11 AM invited presentation

**AMERICAN OSTEOPATHIC COLLEGE OF
PHYSICAL MEDICINE & REHABILITATION**

Annual Meeting 21-25 October 2001 San Diego Convention Center Room Three

Peter G Markos, DO President & Program Chair

Barbara Guerra Executive Director (847) 825-2515 and (Fax) 825-2509

Annual.Meeting@aocpmr.org

26 Credit Hours Category 1-A with additional opportunities for 19.5 hours (Maximum **45.5 potential hours**)

CME/Registration Fees **\$495** (Students/Residents **NO charge**) ON-SITE or ON-LINE REGISTRATION

<http://www.aoa-net.org/Convention/convention.htm>

MONDAY 22 OCTOBER

9am "Spasticity" **Michael S Jaffe, DO** (PM&R, Kaiser Permanente, San Diego)

10am "Neurology of Awareness" **Edward R Chaplin, MD** (Neurology/Peds/Neonatology, Med Dir, Continental Rehab Hosp SD)

11am "On-line Medical Texts & Software Tools" **Milton J Klein, DO** and **Benjamin M Sucher, DO** (FAOCRM/FAOCPMR)

12noon "Other Internet Resources for Patient & Physician" **Drs Sucher, Markos, and Klein** (FAOCRM/FAOCPMR)

1:15pm DO School Alumni Luncheons at the Marriott or Hyatt host hotels north of the Convention Center

2:45pm 29th Annual Webber Memorial Lecture "The Bubble Bursts: DRG Exemptions Lost to PPS" **Margaret**

Fankhauser, DO

(PM&R Dept Chair, Michigan State University College of Osteopathic Medicine FAOCRM/FAOCPMR)

3:45pm AOCPMR Business Meeting for all members including Election of Officers

7pm DINNER "Practice Marketing & Management" **Irving I Haber, DO** (AOCRM/AOCPMR; Indiana University Dept PM&R)

Advance Res' Required RSVP \$75 (\$25 Residents) www.TopOfTheCove.com and www.LaJollaCove.com/beaches.htm/

TUESDAY 23 OCTOBER

8am "Vertebroplasty/Kyphoplasty: New Hope for Painful Compression Fractures" **Wade H Wong, DO** (UCSD Medical School)

9am "Common Spinal Injection Procedures for Diagnosis & Treatment of Back Pain" **Dr Wong** (Interventional Neuroradiology)

10am "ACL Injuries Update" **Robert S Gotlin, DO** (Beth-Israel Hospital of NYC; PM&R Consultant NY Nicks & NJ Nets)

11am "Validation of the Shoulder Exam" **Dr Gotlin** (above)

1pm "Neurology of Burns" **Robert L Marks, MD** (PM&R/Neurology, UCSD and UCLA Medical Schools)

2pm "Wasting & Anabolics" **Dr Haber** (above)

3pm "Psychiatry of Brain Injury" **Walter W Strauser, MD** (PMR/Psychiatry, Sharp Rehab Hospital, San Diego)

WEDNESDAY 24 OCTOBER

8am "Tremors" **Linda J Nienstredt-Jaffe, MD** (Neurology, Kaiser Permanente, San Diego)

9am "Neuromuscular & Neuropathic Pain" **Leonard B Kamen, DO** (AOCRM/AOCPMR; Moss Rehab, Temple University)

10am "Urban Legend in the Making: OxyContin" **Philip F Fisher, DO/PhD** (AOCRM/AOCPMR; Appalachian Pain Foundation)

11am "Advances in Optical Based Imaging, the Breast Cancer Model" **James Leatham, MS**

1:30pm "Occupational & Environmental Assessment Tour of US Navy Aircraft Carrier Constellation" bus transport free to members www.navy.mil/homepages/cv64/ Advance Reservations Required RSVP (Joint Session with the American Osteopathic College of Occupational & Preventive Medicine)

Appendix: Institutional Review Board Protocol Submission

TITLE OF PROJECT: Real Time Handheld Near Infrared Breast Cancer Imager

PI: Linda K. Olson, M.D.
Professor of Clinical Radiology
Department of Radiology

Co-PIs: Georgia Robins Sadler, Ph.D.
Professor
UCSD School of Medicine

Elizabeth A. Gilpin, M.S.
Professor
UCSD School of Medicine

James Leatham, MSEE
Chief Technical Officer
Applied Photonics

Manli Shi, Bachelor of Medicine
Associate Professor, Beijing Medical Univ.
UCSD Guest Researcher

1. Facilities. Patients will be studied at the following sites:

Women's Center 4th and Lewis Street
Thornton Hospital Radiology Department
Perlman Cancer Center

2. Duration of the Study. This pilot study will accrue 20 patients over a twelve month period of time.

3. Specific Aims. The use of optical imaging of the breast with near infra-red light may provide a portable, fast and economical approach to breast tumor detection by portraying angiogenesis and measuring relative deoxygenation of hemoglobin with respect to normal tissue. The goal of this pilot study is to test our methodology by evaluating nursing, technical and physician time; recruitment procedures; use of equipment and recording of results. The intent is to broaden participation in this investigation and to increase the recruitment pool to accelerate the pace of research. The results will be shared with the University of Pennsylvania for further interpretation and feedback. Contingent on the data quality and learned methodology we anticipate initiating a more comprehensive study in the future. Human subjects are necessary because there is no model that simulates the female breast with its cyclic hormonal milieu or its variability in size and composition.

4. Background and Significance. The high incidence of breast cancer and the increasing awareness of high risk groups due to genetic/environmental factors demands prompt action in development of novel, efficacious, safe and affordable technologies. The rapidity of the examination, patient comfort, and safety must be emphasized and given sufficient high priority to reach those populations not reachable previously, and in whom cancer can be detected safely and rapidly.

The use of optical imaging of the breast with near infrared (NIR) light provides a highly portable, fast and economical approach to breast tumor detection. This optical method will take into account two measures that are currently unavailable with ultrasound or x-ray mammography, namely, angiogenesis (measurement of tumor blood volume with respect to normal tissues), and hypermetabolism

(measurement of the relative deoxygenation of hemoglobin with respect to normal tissue). It is hypothesized that the NIR optical method can achieve high sensitivity/specificity on a population of breast cancer subjects.

Description of the Optical Imager: The Amplitude Cancellation System. Cancellation of one signal against another was the basic principle of the "dual wavelength" spectrophotometer (1,2) where time-sharing of two wavelengths gave remarkable sensitivity in spectroscopic observations in highly scattering material (3). Here we use dual wavelengths but have two equidistant detectors with outputs adjusted to equality. The dual wavelength system was constructed with an expedient design using amplitude cancellation only, operating at zero frequency. The dual wavelength system used 760 and 830 nm laser diodes which were time sequenced at 50 μ sec with respect to 21 silicon diode detectors with appropriately attached amplifiers sensitive to wavelengths of 760 and 830 nm (4). The 5 msec light pulse was sequenced through the various source/detector combinations in approximately 100 msec. Averaging of the imaged data over 1 sec gave a very high signal to noise ratio in detecting inhomogeneities of the breast with respect to the surrounding tissue or to the contralateral breast in voxels containing blood volume and oxygenation changes corresponding to the presence of tumors or related tissue pathologies.

Rationale for Cancer Detection: Choice of Signals and References. The optical method offers a remarkable diversity of signals including information on blood volume and blood deoxygenation. These quantities are basically derived from the tissue optical properties, namely absorption μ_a ($\sim 0.04 \text{ cm}^{-1}$) and reduced scattering coefficient μ_s' ($\sim 10 \text{ cm}^{-1}$). These two quantities, measured as a function of wavelength, can be used to derive the above mentioned quantities (blood deoxygenation, amount of blood), and volume of lipid and water. These properties differ in pre- and post-menopausal breasts. The prominent characteristics of adipose tissue are absorption (μ_a) less than 0.02 cm^{-1} and scattering μ_s' less than 10 cm^{-1} based upon 700 measurements by K. Kang (5) and further studies by others (6-9). These optical properties have been found to vary with the estrogen level as modulated by the menstrual cycle in normal women (6,10) and it is expected that they would vary significantly with therapeutic measures for breast cancer that alter the estrogen level. While these parameters can surely be of interest in other studies, we have focused upon the two parameters that may distinguish cancer from non-cancer states, namely increased angiogenesis (blood volume) and hypermetabolism (deoxygenation). These two parameters may be rapidly determined with a simple instrument that uses light pulses as shown here. Delineation of μ_a and μ_s' may require time and frequency domain technologies which while readily available, are more cumbersome and slower than the light pulse device employed here.

The blood volume signal is incrementally observed with respect to the adipose tissue background due to the increased vascularity of the tumor as a consequence of angiogenetic factors. This may include actively metabolizing regions and necrotic/apoptotic regions of the tumor. The deoxygenated volume is, on the other hand, specifically related to metabolic intensity, i.e., the balance between oxygen delivery and oxygen uptake which in tumors is usually balanced in favor of oxygen uptake exceeding oxygen delivery, particularly for those tumors which are aggressively growing.

Apparatus Description. The instrument itself consists of sponge rubber or neoprene pads which can be placed over both breasts and adjacent chest with intervening Saran Wrap. The light sources are activated serially. A complete scan is to be completed in a few seconds. The geometry of the array is a key to our image resolution: each source is equidistant from a pair of detectors and cancellation of the intensities occurs. Thus, a null plane is established passing through the source and midway between the detectors. This pattern is sequenced rapidly for all source detector pairs so that images from any part of the sponge pad can be rapidly processed. The system consists of three units: 1) the imager pad which is spread upon the subject's chest; 2) a laser diode or LED sequencing and data processing card; this card can be installed directly in a PC; and 3) a Personal Computer with an Intel 486 processor or equivalent.

The Nature of the Signals. This is part of the first survey of correlated blood volume increases and hemoglobin deoxygenation in human breast tumors. Vaupel has adequately documented in animal and many tumors the existence of hypoxia in tumors (11), and increased blood volume. Optical detection of these two key parameters appears to have significant sensitivity and specificity, the cancer signals are several-fold greater than the average non-cancer signal.

Imaging Procedure. The imager (See Fig. 1) is first calibrated on a breast model by adjusting all outputs to be equal, hence their differences are zero. The subject or the attendant then holds the imaging pad over a mammographically designated portion of the breast which might or might not include the nipple region. The mirror image region on the contralateral breast is also recorded. The images are acquired in 1 sec from each breast. The 10 x 10 cm² active area of the amplitude cancellation probe covers a suspicious mass. In these studies, no matching fluid is used since the portion of the breast underneath the probe and the underlying chest ameliorate the boundary conditions for imaging tumors in the breast and very little boundary anomaly is found in these images. Furthermore, the thickness required with this geometry is usually no more than 4 or 5 cm with a large adipose breast spread over the chest.

Details of Procedure. The imager pad is smaller than the breast and approximately 7x7 cm and contains a number of sources and detectors. These sources project light through the breast tissue, some of which passes through the tumor and reaches several detectors. On this basis using many source/detector combinations, a back projection image of the tumor is obtained. The wavelengths of light are suited for detection of the total amount of hemoglobin in the tumor and the desaturation of blood in the tumor. Both these measures are appropriately imaged and if they arise from the same voxels, a score is made combining both blood concentration and blood desaturation. This has been found to be a robust criterion for breast cancer identification. The patient is usually supine in this study so that the breast is smoothed over the chest. Mammographic films, ultrasound imaging, and images derived from the breast optical imaging device will be compared. Also, patient history and demographic information will be obtained from the patient.

Two Wavelength Amplitude Cancellation Image System

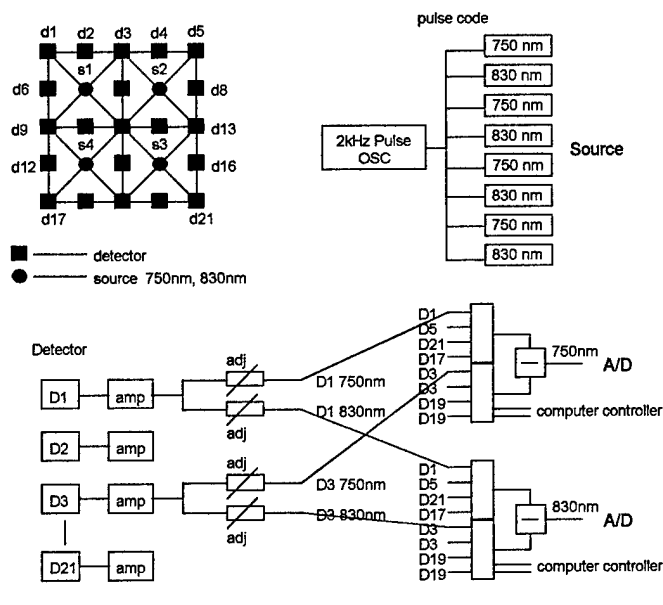

SMZ 9C

Fig. 1. The imager employs four sources and 21 detectors that are time shared in a time driven multiplex system as shown in the diagram. The changes in the balanced output are inputs to the A/D inputs to the PC by which the back projection imaging program is used to calculate the images shown below.

Data Presentation

Step 1: The images are presented as seen by the imager array depicting the “suspicious mass” in Fig. 2 (right and left breast with reference to a breast model), for wavelengths of 750 and 830 nm and the sum and difference signals are imaged as blood volume and deoxygenation, respectively. These images clearly show a mass in Fig. 2 (tumor) and also heterogeneous glandular or ductile images that appear not to interfere. The scales of the ordinates and abscissa are in millimeters, usually 0-60, whilst the intensity scales are in volts, usually 0-3 V, with respect to the model. No negative values for blood volume and positive and negative values are measured for deoxygenation. These voltages are converted to concentrations by model tests and blood volume changes are $\sim 10 \mu\text{M}$.

Step 2: The next phase of data analysis enhances the contrast by presenting the difference image of the two breasts. Here, for example, the contrast is due to the difference between the breast containing a suspicious mass and the contralateral normal breast. Blood volume and deoxygenation images are presented.

Step 3: Spatial congruence of the tumor blood volume and deoxygenation images is sought as in Fig. 2. This congruence must be within ± 5 mm for scoring purposes. In cases where there is no congruent image pair, and only one image, the congruent background signal within ± 5 mm is measured as the score.

Step 4: Where a blood volume image is found, and there is no congruence with the deoxygenation image, no cancer is present.

AMPLITUDE CANCELLATION SYSTEM HUMAN BREAST TEST

(ER:18 11/26/97)

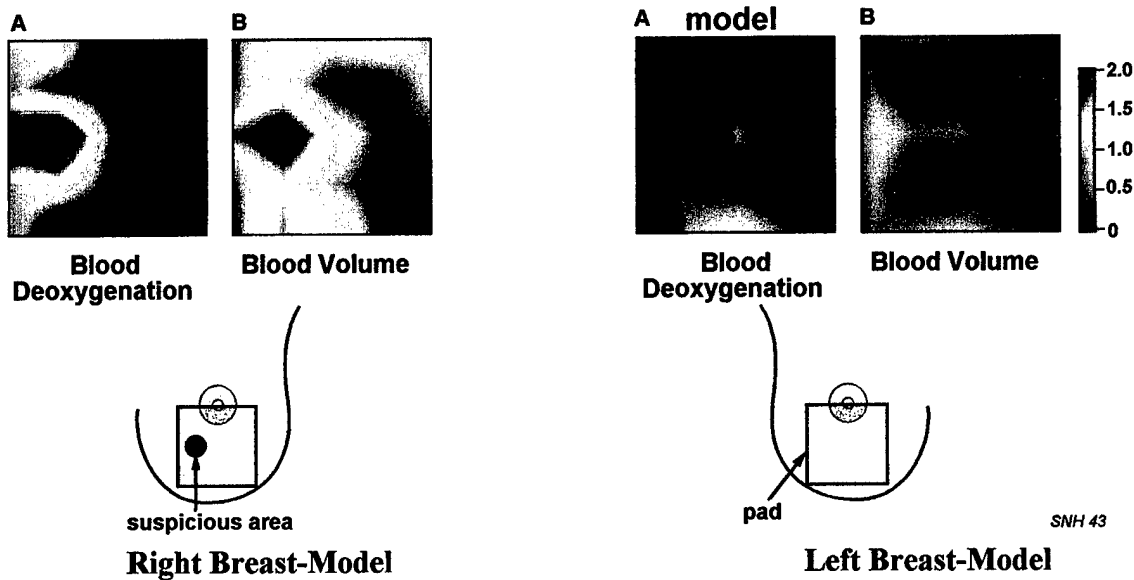

Figs. 2. Images of cancerous breast (right breast) and normal breast (left breast) versus a breast model ($\mu_a = 0.04$, $\mu_s' = 10$). In 3b blood volume is calculated as $(0.3 \times (760 \text{ nm signal}) + 1.0 \times (830 \text{ nm signal}))$. In 6A deoxygenation is calculated as the 760 nm signal minus the 830 nm signal. The signal voltage scale in volts is at the right. The size of the image is $\sim 9 \times 9$ cm. This scale is readily converted to changes of concentration by model tests and the blood volume changes are $\sim 2 \mu\text{M}$ and the desaturation of HbO_2 is nearly 100% in the tumor (left figure).

Output Data. Real time images can be obtained from the breast imager pads.

Data Processing. The magnitude of the tumor images can be read directly from the scale supplied. Thus, fine structural details of the images are not used. Thus Radiologist training is minimal, i.e., reading, in fact, rating of the images can be automated.

5. **Preliminary Studies** This study follows a promising pilot study conducted this year at University of Pennsylvania (Shoko Nioka, M.D., Ph.D. & Britton Chance, Ph.D, co-PI's) and follows a similar protocol. That study has recruited 65 subjects and shown for 12 cancers a true negative rate of 98% and a true positive rate of 100% when used to classify the acquired data on 12 cancers. The results of this University of Pennsylvania study have been submitted for publication when 30 cancers are studied. In that study, no adverse or untoward effects were experienced.
6. **Research Design and Methods.** 20 women with palpable or non-palpable breast masses (visualized by mammography or breast ultrasound) will be recruited from the breast imaging service and from the breast surgery practices of Drs. Wallace, Bouvet and Easter. All patients will have had a recent mammogram as part of their routine medical care. This may have been a routine screening mammogram or a diagnostic mammogram in a symptomatic woman. All masses will have a focused breast ultrasound as part of the work-up of a mammographic abnormality or a palpable lesion. Simple cysts will be included in the study since they will provide a gold standard for a true negative lesion.

Patients will be invited to participate in the experimental optical study just prior to their biopsy procedure or breast ultrasound examination in the radiology department or in the surgeon's office. The patient will be gowned and lie supine on an exam table. A sanitary plastic wrap will be placed over the patient's chest. The imager pad is protected with sponge rubber and held gently against the breast directly over the palpable or mammographic mass. Images are acquired within 10 seconds. The imager pad will then be placed in the mirror position on the opposite breast and images acquired of presumably normal breast tissue. All non-cystic masses will then be biopsied by either fine needle aspiration (FNA), core biopsy or excisional biopsy. Results of the optical imaging device will be compared with the mammogram, ultrasound, physical breast exam and histology results at the end of the project. Mammograms will be reported according to the BIRADS assessment system. Patient identity will be confidential and clinical decisions will be based only on the mammographic, sonographic and physical exam findings. At the end of the project, the results will be shared with Dr. Britton Chance at the University of Pennsylvania.

This study is planned to establish the mechanics of performing the procedure and if successful, to provide the basis for a larger clinical trial.

7. **Human Subjects.** We will study 20 women of all ages and ethnicity with palpable or mammographic breast masses. Pregnant women will be excluded. Women will be invited to participate by a nurse, radiologic technologist, or physician just prior to a biopsy procedure or after a breast ultrasound which showed a cystic lesion.
8. **Informed Consent.** The nurses for Drs. Bouvet, Easter and Wallace and the UCSD mammography technologists will tell women who are seeing their doctor for a procedure related to their suspicious breast mass that a new pilot study is underway at UCSD. They will ask women if they may give them some information about the new study so they can consider whether they would like to participate in it. . They will give the patient a short, printed description of the study and the experimental diagnostic procedure that is being used in the study. The women will be told that one of the physician investigators will personally explain the study to them and answer their questions about the study. The nurse or technologist will not perform the actual procedure.

When the patient is already gowned for another procedure at the collection center, the MD investigators will fully explain the study to the subjects and encourage the patient to ask any questions. When the patient has been fully informed and indicates that she is interested in participating in the study, she will be asked to sign the consent form.

Proprietary Interest Disclosure: The Principal Investigator and co-investigators have no economic interest in this research. The data collected may be used for a grant application and may be submitted for presentation at scientific meetings, publication in a scholarly scientific journal, and shared with other investigators.

9. Therapeutic Alternatives. Not applicable.

10. Potential Risks. There are no known potential risks. Furthermore, the medical device employed is separated from the body by Saran wrap and the light sources involve insignificant amounts of energy (FDA Class I). The instrument uses laser diodes that are within the FDA Class I safety assurance. The imager pad is separated from the breast by Saran film and thus no contact with the chest is expected, or in cases where contamination might occur, the imager probe can be made to be disposable. Patient confidentiality will be maintained. All patient information will be numerically coded to retain patient confidentiality and identifiable patient information will be stored in a separate relational database using the same numerically coded identifier.

11. Risk Management. Since patients are taking part in the evaluation of a new diagnostic procedure there is no assurance that the procedure reliably predicts the presence of breast cancer. Thus the greatest risk is that someone could access the participants data and misuse it. To reduce this risk, identifiable data will be maintained in a separate, relational database with only common numeric code numbers to link the two databases. Based on the available information about the procedure, no physical risks are anticipated. The procedure is not invasive. Nor have reports of physical or mental discomfort have not been reported by the prior participants at the University of Pennsylvania. However, we will remain vigilant to this possibility and inquire about the women's comfort during and following the procedure. Given that the women participating in this study are eligible because a suspicious mass is being evaluated, the women in the study are anticipated to already have an elevated level of anxiety and distress. Every effort will be made to not increase this as a result of the procedure.

12. Potential Benefits. There are no known immediate potential benefits associated with participating in this research study, however, information gathered for this study may lead to developments in design of future diagnostic tools. This may give the women who participate in the study the satisfaction of knowing that they are taking part in research that might help to advance scientists' and physicians' search for better ways to diagnose breast cancer.

13. Risk/Benefit Ratio. There are no known risks. The potential benefit is the development of a novel, highly portable optical breast tumor imager to effectively perform clinical evaluation of currently underserved populations: one pertaining to suspicious masses and a second to high risk breast cancer populations, especially the younger subjects whose breasts are mammographically dense and for whom x-ray mammography may be less than optimal. The breast optical imaging device is believed to be more appropriate for today's managed health care systems where low costs of acquisition and maintenance are emphasized, as well as maximized imaging speed and minimized skilled personnel costs.

14. Expense to Subject. The procedures will require no expense or additional travel on the part of the subject, except for an increase in her exam time.

15. Payment for Participation. We will pay each subject \$50 from money set aside in an NIH grant to the University of Pennsylvania for volunteering to participate in the program to defray inconvenience. This is expressed in the consent forms.

16. Privileges/Certifications and Licenses. Dr. Linda Olson is an M.D. who is Chief of Breast Imaging at UCSD, she will be interpreting the mammograms, breast ultrasounds and performing some of the breast biopsies. Dr. Manli Shi, on academic leave from her post as an Associate Professor and Surgeon at the School of Oncology at Beijing Medical University (China), is a visiting physician who is working under the auspices of Dr. Georgia Robins Sadler. Among her other training assignments, she will be trained to perform the experimental optical imaging procedure. Dr. Sadler is a licensed nurse and an Associate Professor Surgery and Associate Director for Community Outreach at the UCSD Cancer Center. James Leatham is an MSEE who has expertise in optical physics. He is working with Dr. Britton Chance, Professor Emeritus at the University of Pennsylvania, on this facet of optical imaging. Elizabeth Gilpin is the Director of the UCSD Cancer Center's Biostatistics Core Support Unit. She will provide statistics support on this project.

17. Bibliography. Literature cited:

1. Chance, B. (1951) Rapid and Sensitive Spectrophotometry. III. A Double beam Apparatus. Rev. Sci. Instru. 22:634-638.
2. Chance, B., Legallais, V. and Schoener, B. (1963) Combined Fluoroeter and Double Beam Spectrophotometer for Reflectance Measurements. Rev. Sci. Instru. 34:1307-1311.
3. Chance, B., Cope, M., Gratton, E., Ramanujan, N. and Tromberg, B. (1998) Phase Measurement of Light Absorption and Scatter in Human Tissue. Rev. Sci. Instrum. Rev. Sci. Instru. 689:3457-3481.
4. Ma, H.Y., Du, C.W. and Chance, B. (1997) A Homodyne Frequency-Domain Instrument - I&Q Phase Detection System. in *Optical Tomography and Spectroscopy of Tissue: Theory, Instrumentation, Model, and Human Studies II* (Britton Chance, Robert. R. Alfano, Eds), Proceedings of SPIE 2979:826-837.
5. Kang, K.A., Chance, B., Zhao, S., Srinivasan, S., Patterson, E. and Trouping, R. (1993) Breast Tumor Characterization using Near-Infra-Red Spectroscopy. SPIE Proceedings Vol. 1888 Photon Migration and Imaging in Random Media and Tissues (Chance, B. and Alfano, R.R., eds.) SPIE, Bellingham, WA, pp. 487-499.
6. Tromberg, B.J., Coquoz, O., Fishkin, J., Pham, T., Anderson, E.R., Butler, J., Cahn, M., Gross, J.D., Venugopalan, V. et al., Non-invasive measurements of breast tissue optical properties using frequency-domain photon migration, Philosophical Transactions of the Royal Society of London Series B-Biological Sciences 352 (1354), 661-668 (1997); see also Madsen, S.J., Anderson, E.R., Haskell, R.C. and Tromberg, B. (1994) Portable, High-bandwidth Frequency-Domain Photon Migration Instrument for Tissue Spectroscopy. Optics Lett. 19:1934-1936.
7. Ntziachristos, V., Ma, X.H., and Chance, B., (1998) Time-correlated single photon counting imager for simultaneous magnetic resonance and near-infrared mammography, Review of Scientific Instruments 69 (12), 4221-4233.
8. Pogue BW, Testorf M, McBride T, Osterberg U, Paulsen K. (1997) Instrumentation and design of a frequency-domain diffuse optical tomography imager for breast cancer detection. Optics Express 1(13).
9. Hebden JC, Schmidt FEW, Fry ME, Schweiger M, Hillman EMC, Delpy DT, Arridge SR (1999) Simultaneous reconstruction of absorption and scattering images by multichannel measurement of purely temporal data OPTICS LETTERS 24: (8)534-536 APR 15; see also Hebden, J.C., Tziroli, M., Delpy, D.T. (1997) Evaluation of the Temporally Extrapolated Absorbance Method for Dual-Wavelength Imaging Through Tissue like Scattering Media. Appl. Opt. 36:P.3802
10. Tanaka, H., Kaneko, M., He, P., Suzuki, K., Furuhashi, N., Kodaira, T., Kimura, M., Kasami, Y., Yamashita, Y and Ohta, K. (1991) Trial of Breast Disease Diagnosis by Laser Transmission Photo-a-Scanning (LTPS): Possibility of Application to MassSurvey. Innervision, 6:2-6.
11. Vaupel, P. *Biological Basis of Oncologic Thermotherapy*. (Gautherie, M. ed., (Springer-Verlag, New York, NY) pp. 73-134

18. Industry Studies. This is not an industry-supported study and it is not part of a protocol for testing of a medical device. The study is intended to coordinate investigative efforts and establish a collaborative working relationship using an apparatus developed under NIH funding at the University of Pennsylvania.

19. Other Funding. This research is supported in part by NIH funding to the University of Pennsylvania. This support consists solely of payments to patients, support of travel and incidentals, and to pay for expendables and supplies, such as Saran Wrap and exam gloves.

20. For Cancer Studies. Completed and submitted

21. Biological Materials Transfer Agreement. Not applicable

22. Investigational Drug Fact Sheet. Not Applicable

23. Conflict of Interest See attached form(s) 730-U.

24. Nursing Staff. The nurses for Drs. Bouvet, Easter and Wallace and the mammographic technologists will ask women if they would like to participate in this study. They will give the patient a short, printed description of the procedure. The participating physician investigator will explain the study to the patients. If the patient elects to participate, the physician or the nurse will obtain her written informed consent. The nurse or technologist will not perform the actual procedure. Presenting the option to participate will marginally increase the required nurse contact time with each patient. Familiarity with the study and the consent forms will be required. No additional training or skills will be needed.