

REPORT DOCUMENTATION PAGE

Form Approved
OMB NO. 0704-0188

Public Reporting burden for this collection of information is estimated to average 1 hour per response, including the time for reviewing instructions, searching existing data sources, gathering and maintaining the data needed, and completing and reviewing the collection of information. Send comment regarding this burden estimates or any other aspect of this collection of information, including suggestions for reducing this burden, to Washington Headquarters Services, Directorate for information Operations and Reports, 1215 Jefferson Davis Highway, Suite 1204, Arlington, VA 22202-4302, and to the Office of Management and Budget, Paperwork Reduction Project (0704-0188,) Washington, DC 20503.

1. AGENCY USE ONLY (Leave Blank)

2. REPORT DATE

3. REPORT TYPE AND DATES COVERED
FINAL JANUARY/1997 TO JULY 2002

4. TITLE AND SUBTITLE
INNOVATIVE TECHNOLOGIES FOR ACTIVELY CONTROLLED JET-SMOOTH QUIET ROTORCRAFT
FY96 MURI ON ROTOCRAFT VIBRATION AND ACOUSTICS

5. FUNDING NUMBERS
35899-EG-MUR
DAA-H04-96-10334

2003 JAN 10 AM 10:22

6. AUTHOR(S)
INDERJIT CHOPRA

7. PERFORMING ORGANIZATION NAME(S) AND ADDRESS(ES)
DEPT. OF AEROSPACE ENGINEERING
UNIVERSITY OF MARYLAND
COLLEGE PARK MD 20742

8. PERFORMING ORGANIZATION
REPORT NUMBER N/A

9. SPONSORING / MONITORING AGENCY NAME(S) AND ADDRESS(ES)

U. S. Army Research Office
P.O. Box 12211
Research Triangle Park, NC 27709-2211

10. SPONSORING / MONITORING
AGENCY REPORT NUMBER

35899.4-EG-MUR

11. SUPPLEMENTARY NOTES

The views, opinions and/or findings contained in this report are those of the author(s) and should not be construed as an official Department of the Army position, policy or decision, unless so designated by other documentation.

12 a. DISTRIBUTION / AVAILABILITY STATEMENT

Approved for public release; distribution unlimited.

12 b. DISTRIBUTION CODE

13. ABSTRACT (Maximum 200 words)

The status of a number of rotorcraft research tasks supported under the Army Research Office FY96 MURI on Rotorcraft Vibration and Acoustics program is reported herein. Each of over twenty tasks conducted under this program are briefly detailed in an extended abstract format. Readers are encouraged to contact the individual task leaders for more detailed and comprehensive information including journal and conference paper citations. For each task, the following items are presented: the task objectives, the approach being taken, the status of the research at the end of the program of research, collaborations undertaken with government and industrial scientists, and a list of publications in conference proceedings and archival journals.

14. SUBJECT TERMS

15. NUMBER OF PAGES
71

16. PRICE CODE

17. SECURITY CLASSIFICATION
OR REPORT
UNCLASSIFIED

18. SECURITY CLASSIFICATION
ON THIS PAGE
UNCLASSIFIED

19. SECURITY CLASSIFICATION
OF ABSTRACT
UNCLASSIFIED

20. LIMITATION OF ABSTRACT
UL

NSN 7540-01-280-5500

Standard Form 298 (Rev.2-89)
Prescribed by ANSI Std. Z39-18
298-102

20030310 032

**INNOVATIVE TECHNOLOGIES FOR
ACTIVELY CONTROLLED JET-SMOOTH
QUIET ROTORCRAFT**

Final Report to the Army Research Office

ARO # 35899-EG-MUR

Contract No. DAA-H04-96-10334

FY96 MURI on Rotorcraft Vibration & Acoustics

Principal Investigator: Inderjit Chopra

**University of Maryland
The Pennsylvania State University
Cornell University**

**INNOVATIVE TECHNOLOGIES FOR
ACTIVELY CONTROLLED JET-SMOOTH
QUIET ROTORCRAFT**

**Final Report to Army Research Office
Contract No. DAA-H04-96-10334**

The status of a number of rotorcraft research tasks supported under the Army Research Office FY96 MURI on Rotorcraft Vibration and Acoustics program is reported herein. Dr. Tom Doligalski is the Technical Monitor for the project.

For each task, an attempt is made to describe the task objectives, the approach being taken, the status of the research in terms of recent results, problems or changes in approach or objective under each task.

Prof. Inderjit Chopra
Principal Investigator
Director, Alfred Gessow Rotorcraft Center
Dept. of Aerospace Engineering
University of Maryland
Ph: (301) 405-1122

TABLE OF CONTENTS

	Summary of Rotorcraft Tasks and Task Leaders	1
	Technical Statement of Work	2
	MURI Research Team	4
1.	Task 1 - Active Exterior (Rotor) Noise Control	6
2.	Task 2 - Active Interior Noise Control	23
3.	Task 3 - Active Vibration Control	32
4.	Task 4 - Active Transmission Noise / Vibration Control	50
5.	Task 5 - Innovative Concepts for Active Noise and Vibration Control	61
6.	Task 6 - Key Technology Elements	68

Introduction

The Alfred Gessow Rotorcraft Center has been at the forefront in the development of smart structures technology and its application to rotorcraft systems.

Arguably, more than any other aeronautical system, the closely interdisciplinary-coupled structural, mechanical and aerodynamic complexity of rotorcraft offers many potential opportunities to apply smart structures technology to achieve substantial pay-offs in effectiveness. With this in mind, an innovative, integrated, interdisciplinary basic research program was embarked upon in the early 1990s to advance the technology of smart structures in order to make major rotorcraft improvements through the application of this technology. Taking advantage of the expertise, unique research facilities and equipment available at the Alfred Gessow Rotorcraft Center developed under the Army/NRTC's Centers of Excellence program, a major initiative in rotorcraft-focused smart structures was proposed to the U.S. Army. The objective was to expand the technology base of smart structures, examine new and innovative actuators, sensors and control strategies, and pursue high-payoff applications to rotorcraft to suppress external/internal/transmission noise and vibration, and augment aeromechanical stability. The proposed research program was an intensive, coordinated and broad-based effort that interactively considered the rotor, airframe and power train in the active control of noise, vibration and aeromechanical and flight stability.

The Center put together a team of Maryland faculty in the Departments of Aerospace Engineering, Mechanical Engineering, Materials and Nuclear Engineering, the Institute for Systems Research and the Baltimore campus and won a five-year University Research Initiative (URI) entitled "Innovations and Applications of Smart Structures Technology to Rotorcraft Systems" (1992-97) from the Army Research Office. As part of the URI, the basic elements of smart structures pertaining to rotorcraft were developed. Much of the research was directed towards the development and refinements of: hybrid material actuators, magnetostrictive particle actuators, electrostrictive actuators and shape memory alloys actuators; sensors such as fiber optics; smart dampers such as electro-rheological and magneto-rheological fluid dampers; distributed control strategies such as wavelet theories; and analytical modeling of smart structures. Another key component of this research was focused on the development of Froude-scaled smart rotor models: controllable twist models incorporating embedded piezoceramic elements, and trailing-edge flap models actuated with smart actuators to minimize vibration. Because of this program, there has been a phenomenal growth of research activities in smart structures on this campus as well as at other institutions.

Following the success of the smart structures URI, the Center competed for and won a Multidisciplinary University Research Initiative (MURI) entitled "Innovative Smart Technologies for an Actively Controlled Jet-Smooth Quiet Rotorcraft" (1996-2002). For this, we led a team of researchers from the University of Maryland (Aerospace and Mechanical Engineering), Penn State, Cornell, and the University of the District of Columbia. This MURI program further expanded the smart structures technology base by examining new innovative actuators, sensors and control strategies, and addressed high-payoff applications to rotorcraft to suppress external/internal/transmission noise and vibration. Most importantly, this program carried out the next and vital step in the practical application of smart structure technology to full-scale systems by building Mach-scaled rotor models and testing them on our hover stand, in our anechoic chamber and in our wind tunnel.

Today, the Center has established leadership in the smart structures discipline as applied to rotorcraft. For example, at a recent Army sponsored national workshop on smart structures held at Penn State in August 1999, every second paper out of a total of 60 papers had its roots in the Center. During the past four years, Maryland has contributed more papers in the smart structures discipline than any other institution in this country or abroad. The phenomenal production of research and graduate engineers in the area of smart structures focused on rotorcraft are shown in Tables 1. Many of our graduates now work in industry, federal laboratories and academia and are making key contribution to this research area. Table 2 lists research tasks carried out under this MURI program. The research has resulted in significant technology transfer to industry, which now consider smart structures as a viable design option (see Table 3).

The Center has built and tested many different smart rotor systems (see Table 4). As a result of AGRC's initiative, the last decade has seen enormous activities in the application of smart structures technology to rotorcraft, and as anticipated, many of the proposed efforts have come to fruition. In the future, more and more of the technical challenges faced by today's helicopters will be overcome with this technology which will expand into new domains of applications and lead to jet-smooth, efficient and cost-effective rotorcraft.

Table 1: ALGR: Vital Statistics for Smart Structures

Faculty	18
Research Scientists	8
Currently Enrolled Smart Structures Students UM; 46, Penn State: 15, Cornell:1	62
Graduated: Ph.D.	18
Graduated: M. S.	75
Publications: Conference	225+
Publications: Archival Journal Papers	100+

Table 2 - Summary of Smart Structures Tasks and Task Leaders

Task	Activities	Task Leaders
<p>Task 1</p> <p>Active Exterior (Rotor) Noise Control</p>	<p>1.1 Active Noise Control Using Smart Trailing-Edge Flaps (<i>UMD</i>)</p> <p>1.2 Active Leading-Edge Droop for High-Speed Impulsive Noise Control (<i>UMD</i>)</p> <p>1.3 Coupled Aeroacoustic/Aeroelastic Comprehensive Analysis for Actively Controlled Rotors (<i>PSU</i>)</p> <p>1.4 Parameter Delineation, Directionality and Discretization Requirements (<i>Cornell/UDC</i>)</p> <p>1.5 Active Attitude Modification for BVI Noise Abatement (<i>Cornell</i>)</p>	<p>Baeder / Leishman</p> <p>Baeder</p> <p>Long / Gandhi</p> <p>Schmitz</p> <p>George</p>
<p>Task 2</p> <p>Active Interior Noise Control</p>	<p>2.1 Interior Noise Control Studies Using Smart Materials (<i>UMD</i>)</p> <p>2.2 Hybrid Active / Passive Trim Panel Damping Control (<i>UMD</i>)</p> <p>2.3 Interior Noise Control Using Active Piezo Damping Composites (<i>UMD</i>)</p>	<p>Balachandran</p> <p>Wereley</p> <p>Baz</p>
<p>Task 3</p> <p>Active Vibration Control</p>	<p>3.1 Active Vibration Control Using Smart Rotor Tips With Piezo-Induced Bending-Torsion Coupled Twist (<i>UMD</i>)</p> <p>3.2 Active Control of Structural Response (ACSR) Using Smart Actuators (<i>UMD</i>)</p> <p>3.3 Active Stabilator for Tiltrotor Vibration Suppression (<i>UMD</i>)</p>	<p>Chopra</p> <p>Chopra</p> <p>Wereley</p>
<p>Task 4</p> <p>Active Transmission Noise / Vibration Control</p>	<p>4.1 Active Control of Coupled Rotor-Drivetrain-Airframe Dynamics (<i>PSU</i>)</p> <p>4.2 Active Gearbox Struts for Control of Noise/Vibration Transmission (<i>UMD</i>)</p> <p>4.3 Adaptive Multi-functional Sensors for Transmission Noise Suppression and Vibration Control (<i>UMD</i>)</p>	<p>Smith / Wang</p> <p>Balachandran</p> <p>Pines</p>
<p>Task 5</p> <p>Innovative Concepts for Active Noise and Vibration Control</p>	<p>5.1 Use of Dissimilar Rotors for Vibration and Noise Reduction (<i>PSU</i>)</p> <p>5.2 Detailed Aeroelastic/Acoustic Analysis of Double Swept Composite-Tailored Rotor (<i>UMD</i>)</p> <p>5.3 Mach-Scaled Rotor Model with Smart Trailing-Edge Flap (<i>UMD</i>)</p>	<p>Gandhi</p> <p>Baeder</p> <p>Chopra</p>
<p>Task 6</p> <p>Key Technology Elements</p>	<p>6.1 Multiplexed, High Bandwidth Bragg Grating Fiber Optic Sensors For Cabin Noise Control (<i>UMD</i>)</p> <p>6.2 Time-Frequency Analysis of Helicopter Noise (<i>UMD</i>)</p>	<p>Sirkis</p> <p>Celi</p>

Table 3: Technology Transfer from Alfred Gessow Rotocraft Center

Type of Work	Organizaiton	Person
Development of a Full-Scale Smart Rotor System	Boeing-Mesa	Straub
Evaluation of Smart Structures Technology for a Full Scale Rotor System	Sikorksy	Torok
Development of MR Recoil Dampers For A Gun	Army/Piccatiny	Mattice
Rotor Head Fault Detection Methodology Development (JAHUM Program)	Navy: David Taylor	Haas
Assesment of Smart Actuators for Primary Controls and Vibration Suppression	Boeing-Mesa /Army Ft Eustis	Straub/ Merkley
Development of Large-Stroke Hybrid Piezo-Hydraulic Actuator (CHAPS Program)	CSA/DARPA	Anderson/ Garcia
MR Fluid Dampers for Helicopters	Lord Corp.	Lolly
Deveopment of MR Recoil Damper for Appache Helicopter Gun	Army/Aberdeen	Zoltani
Interior Noise Control for Ultrasport Hleicopter Cabin	ATI	McGongle
Diagnostics of Transmission Faults	Sikorsky	Welsh
Active Piezoelectric Damping Composites for Cessna Citation II	NRL	Houston
Development of Large Stroke Smart Actuators for Rotorcraft	Army/Ames	Tung
Diagnostics and Acoustics of Transmission Faults	NASA/Glenn	Lewicki
Active/Passive Hybrid APPN Smart Actuator Technology for Gun-Fuselage Vibration Isolation and Precision Control	ARDEC	Johnson
Development of Active Piezoelectric Dampin g Composites	NRL	Ng
Interior Cabin Noise Control with Smart Actuators: LQG Controllers Development	Scientific Systems	Mehra
Development of Synthetic Jet Control with MEMS Technology	SPA	Chen
Development of Advanced Fiber Optics Sensors	NRL	Friebele
Development of Large-Stroke Single-Crystal Piezo Actuators	Wilcoxon	Wlodkows ki
Development of MR Damper for	SPA	Chen
Development of Wireless Health Monitoring Node for Machinery	Rockwell Science Center	Twaroski
Development of Smart Submunitiion	Army/Aberdeen	Hollis
MR Flow Control Valve	General Dynamics	Ingram
X-Force Concept to Reduce Noise	Bell	Moullins

Table 4: Smart Rotor Development at Alfred Gessow Rotorcraft Center

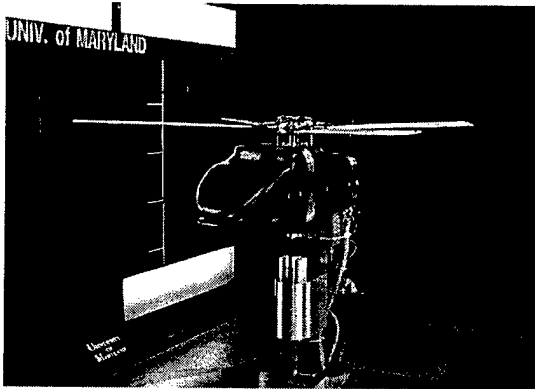

Piezobimorph-Actuated Flap: 6 Ft Dia Rotor Model Test in Glenn L. Martin Wind Tunnel; Successfully Tested In both Open and Closed Loop Studies.

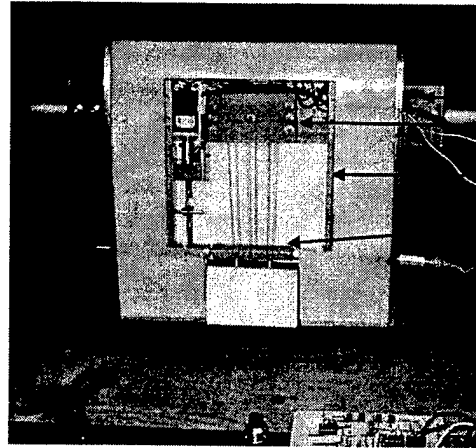

Blade Tab Actuated with Shape Memory Alloys Actuator, Wing Section Tested in Open-Jet Wing Tunnel; Produced Tab Deflections of over 20 deg.

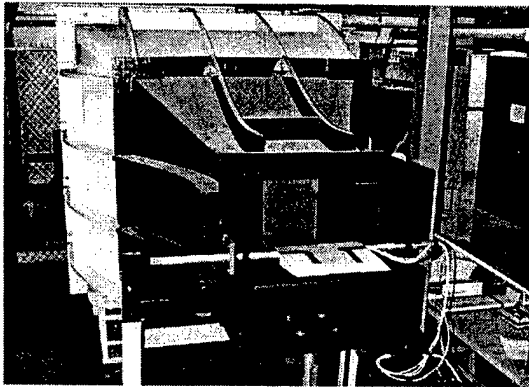

Piezo Stacks Actuated Flap: Full Scale Wing Section Model Tested in Open-Jet Wind Tunnel; Produced ± 6 deg flap deflection

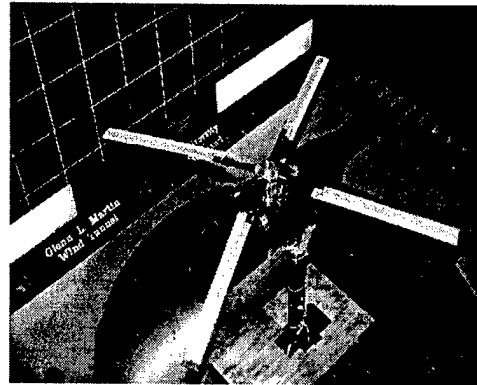

Active Twist Blade with Embedded Piezo Actuators 6 ft. Dia Rotor Test in Glenn L. Martin Wind Tunnel; Produced $\pm .5$ deg blade twist up to 5/rev excitation

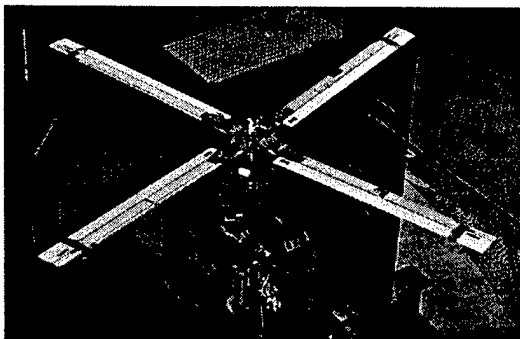

Smart Tip Rotor Model (dia. 6 ft) on Hover Stand, Actuated with composite bending-torsion coupling and piezos; Produced ± 2 deg tip deflections up to 5/rev

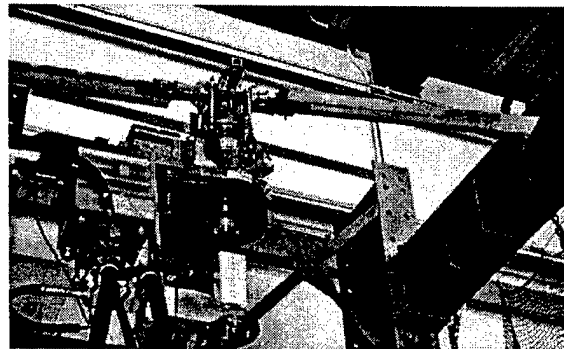

Froude-Scale Rotor Model (6 ft dia) on Hover Tower with Piezobimorph Actuated Flaps

For Details, See, Chopra, I., "Status of Applications of Smart Structures Technology to Rotorcraft Systems," AHS Journal, Oct. 2000

Task 1.1:

Active Noise Control Using Smart Trailing-Edge Flaps

J. D. Baeder, J. G. Leishman
Center for Rotorcraft Education and Research
University of Maryland

Research Objective

To determine the feasibility of implementing smart trailing-edge flaps in order to actively suppress blade-vortex interaction noise and unsteady loading noise.

Approach

Current proposed techniques for active noise reduction (HHC, IBC, etc.) aim to reduce noise and/or vibration by changing the blade path and/or the wake structure and therefore the interactions of the blade with the wake. Because the wake structure is very complicated, it is difficult to derive an approach from first principles for determining the required amplitude and phasing of the blade motion. *Ad hoc* empirical approaches to control are taken; it is difficult to imagine how such a system will realistically be implemented in flight in a robust manner. Thus, the approach to be taken in this task is to improve the fidelity of *computationally fast generalized indicial functions*, which have exact theoretical solutions but not for all time, with the judicious use of CFD and experiments. Simultaneously, experimental work will be undertaken to explore open loop and adaptive control strategies.

Accomplishments

An important part of this research task consists of improving comprehensive aeroacoustic analysis. Leishman has analytically and numerically derived the non-stationary (convecting) sharp-edged gust lift and moment responses for linearized subsonic flow. Although the solution can only be calculated for short periods of time, it shows the trends from moving gusts, as well as serves as a validation for numerical results from CFD. Baeder and Singh applied a 2-D Euler/Navier-Stokes solver, using the Field Velocity method, to investigate numerically non-stationary sharp-edged gusts for subsonic flow. The agreement with the linearized results of Leishman was excellent. In addition, it has been shown that assuming the gust function to be stationary is a poor assumption for predicting the acoustics from moving gust fields. Fortunately, the effect on the unsteady loading is not as large.

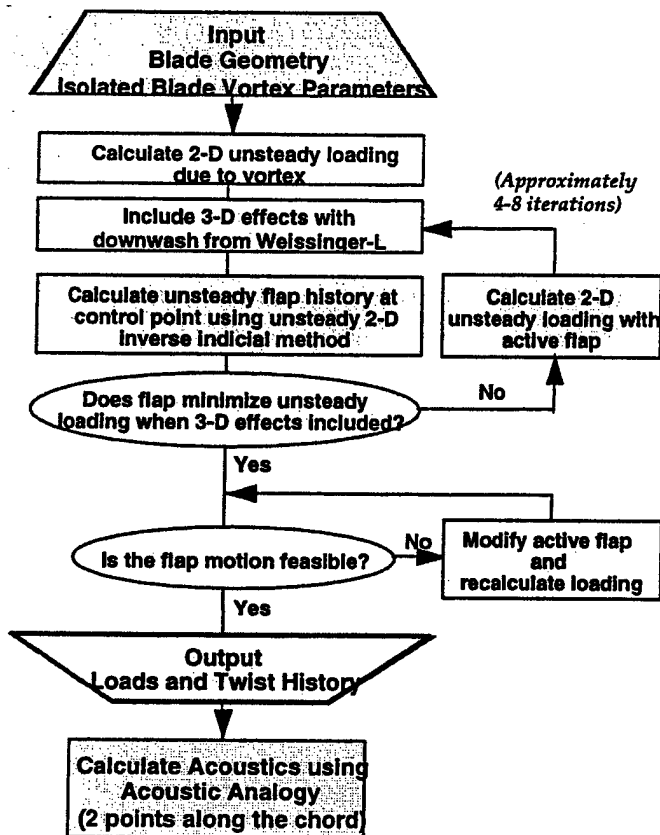

Figure 1. Flow chart for determining flap motion to minimize unsteady loading at control points on actively trailing-edge flap.

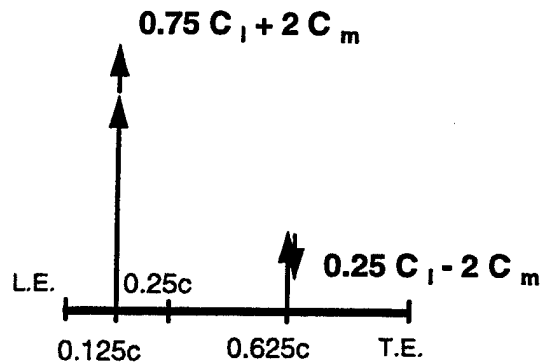

Figure 2. Two-point chordwise approximation for acoustic calculations.

The work was extended to 3-D rotor blades for idealized parallel and oblique interactions using the linearized unsteady aerodynamics coupled with Weissinger-L for active trailing-edge flaps. The successful inversion of the indicial method allows for the calculation of a given flap motion based on the desired lift generation in 2-D. This is incorporated into an overall 3-D scheme to minimize the unsteady loading at various control points as indicated in Figure 1. The resulting time history of aerodynamic loads (lift and moment) are then fed into an acoustic code for linear propagation using a two-point chordwise approximation as shown in Figure 2. Results indicate that at least two finite span flaps are required for oblique interactions. Furthermore, an active linear twist is probably more effective for oblique interaction noise reduction as shown in Figure 3.

Through the use of 2-D CFD calculations, the importance of noncompactness in the chordwise direction was investigated and found to be important for high frequency actuation such that a simple correction due to moments is not sufficient. Furthermore, due to the increasing noncompactness in chord the flaps are not very effective for high frequencies; however, they are more effective for weak interactions. This is due to the fundamentally different acoustic radiation pattern resulting from rapidly moving control surfaces as compared to that from strong blade-vortex interactions.

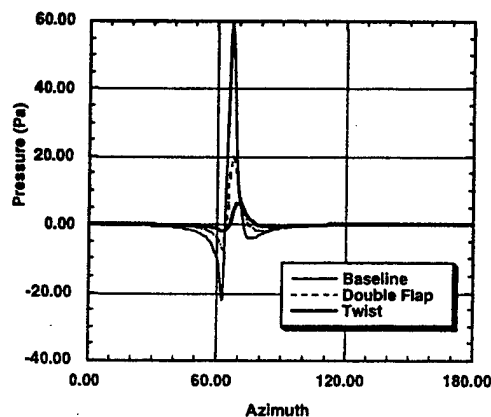

Figure 3. Pressure time histories predicted by linearized unsteady aerodynamics for parallel isolated BVI with unconstrained actuation at BVI hotspots ($\psi=270^\circ$; $\phi=-60^\circ$; $r/R=6.0$).

Through the use of 2-D CFD calculations, the importance of noncompactness in the chordwise direction was investigated and found to be important for high frequency actuation such that a simple correction due to moments is not sufficient. Furthermore, due to the increasing noncompactness in chord the flaps are not very effective for high frequencies; however, they are more effective for weak interactions. This is due to the fundamentally different acoustic radiation pattern resulting from rapidly moving control surfaces as compared to that from strong blade-vortex interactions.

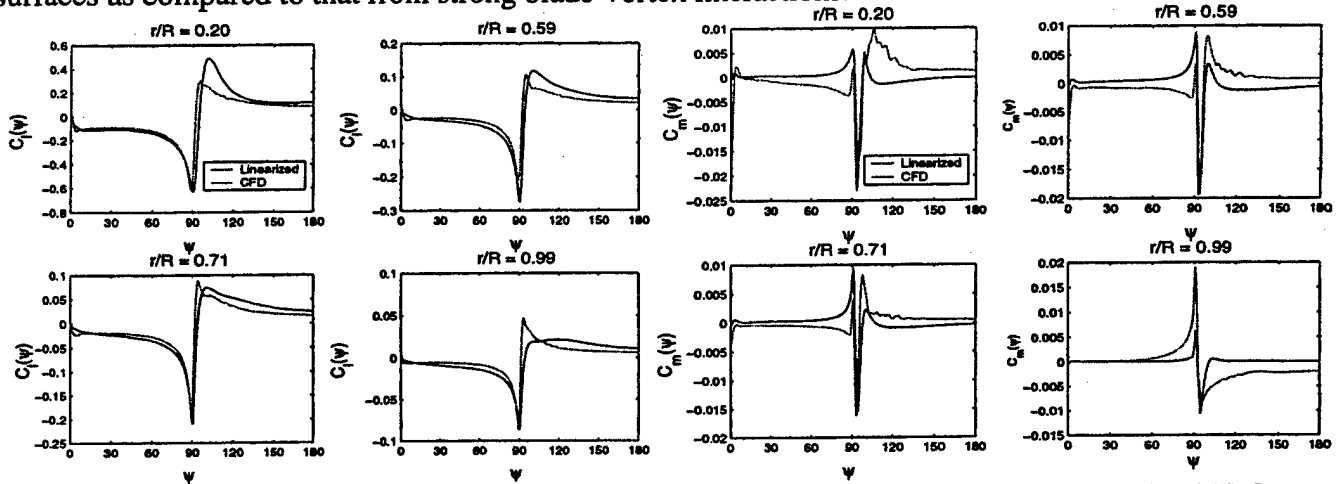

Figure 4. Unsteady lift and moments predicted by CFD and linearized aerodynamics for an isolated blade-vortex interaction.

For the stationary gust case, an optimized indicial approximation was derived for the moment response and successfully applied to BVI. This year it was extended to be a function of Mach number as well as gust ratio. Existing comprehensive codes that treat the wake as a stationary gust neglect such terms from the moment calculations and thus do not predict any moments. This could have a dramatic affect on the dynamic response in pitch from blade-vortex interactions. Therefore, this year a simulation of a 3-D isolated blade-vortex interaction was undertaken using both CFD and the enhanced CFD-based indicial coefficients for lift and moments. The results are shown in Figure 4 for a tip Mach number of 0.6 and an advance ratio of 0.2 for the vortex moving with the freestream.

Furthermore, to better model the resulting chordwise pressure distribution during BVI w/ and w/o control a surface pressure distribution indicial model based on CFD results was developed. As seen in Figure 5, the CFD can output the ΔC_p response as a function of chordwise location as a function of time due to the penetration of a sharp edged gust. As a test of this method, the optimized coefficients for a were extracted for using a recursive relation, just as for the indicial lift or moment response. Figure 6 shows the location of several points in time as well as the CFD predicted lift and moment response due to an airfoil-vortex interaction at $M=0.6$. Figure 7, shows the CFD and indicial surface pressure distributions at the locations noted in Figure 6. As can be seen, the newly developed surface pressure indicial representation is able to calculate the qualitative change in the surface pressure distribution along the chord of the airfoil during the interaction.

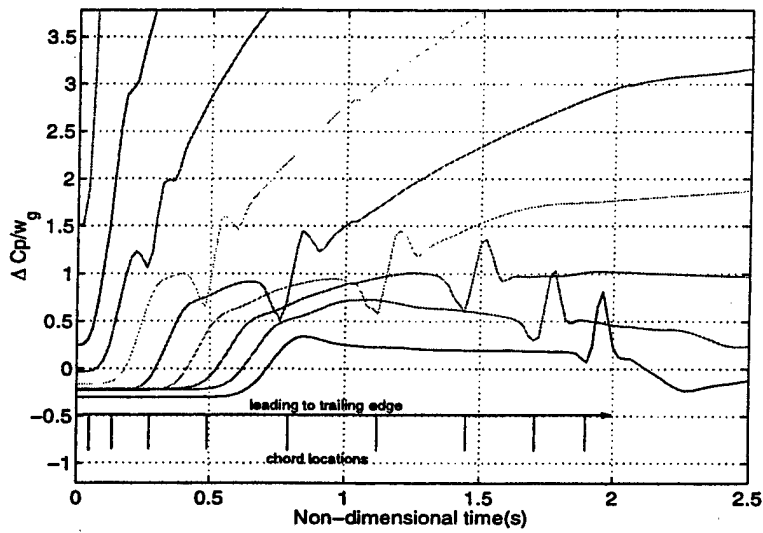

Figure 5. Indicial ΔC_p response at various chordwise locations due to the penetration of a sharp edged gust at $M=0.6$.

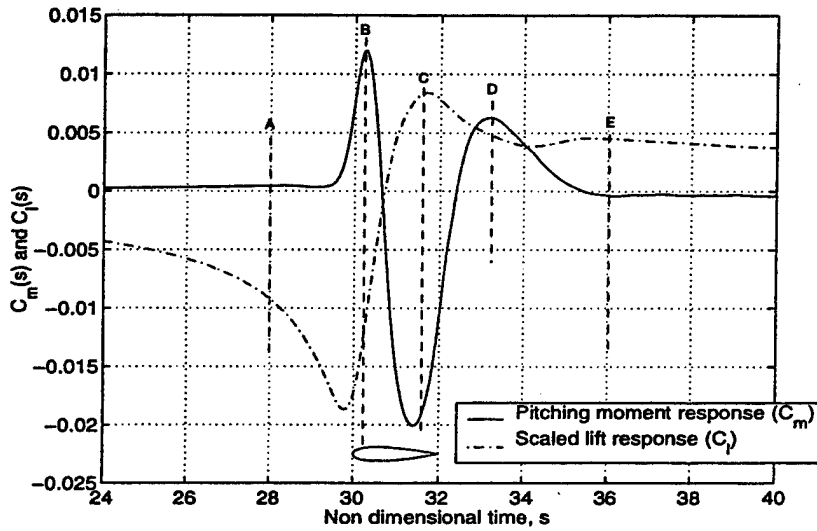

Figure 6. CFD calculated lift and moment time history for an airfoil-vortex interaction.

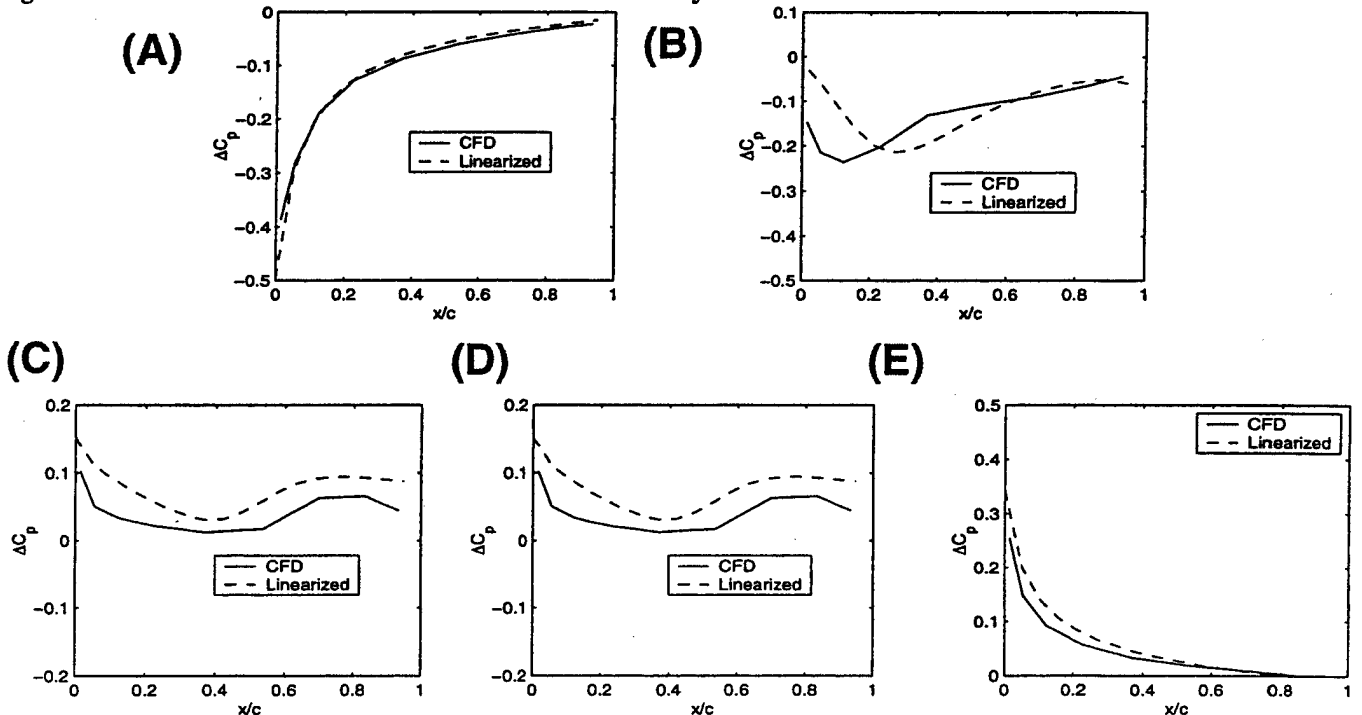

Figure 7. A comparison of chordwise pressure distributions from CFD and linearized aerodynamic analysis at points in time indicated in Figure 6.

Future Work

The ability of indicial functions to adequately model finite span trailing-edge flaps will be validated against fixed wing experiments performed at Army/Langley as well as CFD. The feasibility of using smart-trailing edge flaps for BVI avoidance will be investigated to determine actuator requirements as well as identify similarities and differences to actuation for vibration reduction.

Finally, the ability of the comprehensive aeroacoustic code to model rotors with smart active trailing-edge flaps will be validated with in-house open loop tests.

Significance

This research will demonstrate the feasibility of utilizing smart trailing-edge flaps for active rotor noise reduction, and is a key step to full-scale implementation of this innovative technology. It is expected that such active noise control systems may reduce BVI and other unsteady loading noise by 6dB or more without increasing rotor vibration for weaker interactions.

External Collaboration

Thomas Brooks, Jack Preisser and Ken Brentner at NASA Langley have already been briefed and expressed keen interest in the indicial moving gust work. A similar methodology is being developed with Systems Planning Analysis, Inc. for application to an actively twisting rotor. Perry Ziegenbein and the rest of the acoustics group at Boeing Philadelphia have expressed a keen interest in the indicial modeling.

Publications

1. Wang, B., Baeder, J.D., and Singh, R., "A Computational Study of Trailing-Edge Flap Aerodynamics and", *Proceedings of the 55th American Helicopter Society Annual Forum*, Montreal, Canada, May, 1999.

Task 1.2: Active Leading-Edge Droop for High-Speed Impulsive Noise Control

J. D. Baeder
Center for Rotorcraft Education and Research
University of Maryland

Research Objective

To investigate a rotor with a smart leading-edge droop in the thin tip region to drastically reduce both thickness and HSI noise. The research will involve: (1) CFD analysis of the compressible aerodynamics of a thin smart leading-edge droop airfoil and (2) validation with blade section test data.

Approach

As of this date there has been no attempt to come up with an active device to reduce either thickness or HSI noise. Thus, active methods will be investigated to maintain attached flow on the retreating side for blades with a very thin outboard section, while decreasing thickness and HSI noise on the advancing side. In addition, fluctuations of the surface in the leading-edge region could be used to partially cancel BVI generated noise. A compressible CFD analysis will be applied to very thin airfoils with a dynamically drooping leading-edge to delay the onset of

stall. This work will be validated against experiments performed in the Glenn L. Martin Wind tunnel (a piezo-stack driven actuator capable of drooping the leading-edge of a full-scale blade section, see Figure 1), followed by testing the thin leading-edge droop airfoil with a dynamically adaptive motion.

Accomplishments

An important part of this research task is the utilization of *compressible* CFD analysis capabilities for deformable airfoils (developed under the sponsorship of the NRTC core rotorcraft program at Maryland) to investigate the feasibility of using active leading-edge droop to delay or eliminate dynamic stall for very thin airfoils (suitable for reducing HSI and thickness noise) at realistic helicopter Reynolds numbers. Mechanisms for static stall suppression have been examined computationally using a 2-D Navier-Stokes analysis, and include devices such as leading-edge droop, trailing-edge flaps, and larger leading-edge radius. Of these mechanisms, leading-edge droop appears to be the most promising for reducing the large pressure gradients in the leading-edge region as well as minimizing the occurrence of strong shocks that may induce flow separation. Furthermore, the minimization of the leading-edge motion, though dynamic drooping, maintains these advantages for a rotor section undergoing dynamic oscillations. Computationally, only harmonic motion of the airfoil and drooping in the leading-edge region have been examined to date. This requires very accurate incorporation of the grid time metrics as well as the change in size of the computational cells as the mesh deforms.

Often times the dynamic stall is initiated by the strong compressible flow in the leading-edge region at high angles of attack. Even at freestream Mach numbers of 0.2 compressibility can be important with small supersonic pockets forming and greatly increasing the downstream boundary layer thickness: resulting in leading-edge stall. The reduced acceleration in the leading-edge region during the upstroke and the smaller local flow angle result in attached flow when utilizing the dynamically drooping leading edge at the same conditions for which the base airfoil stalls. This is clearly seen in Figure 2. The

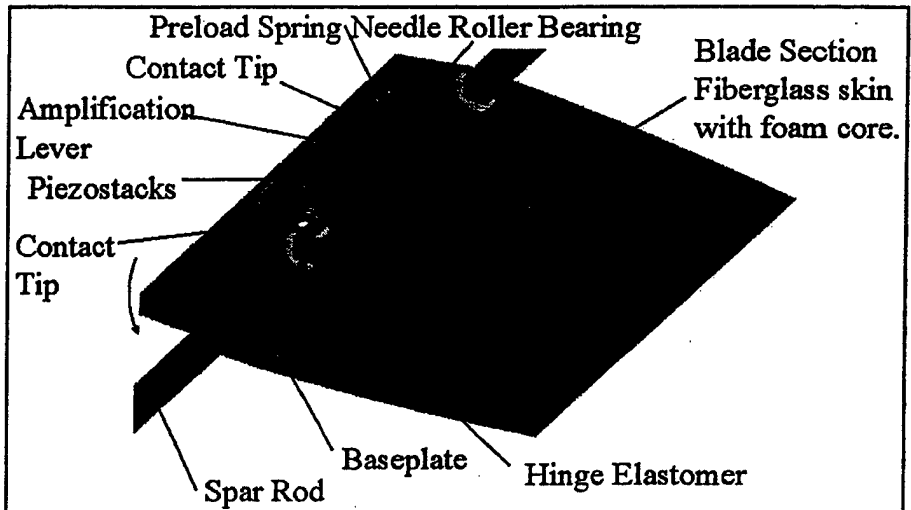
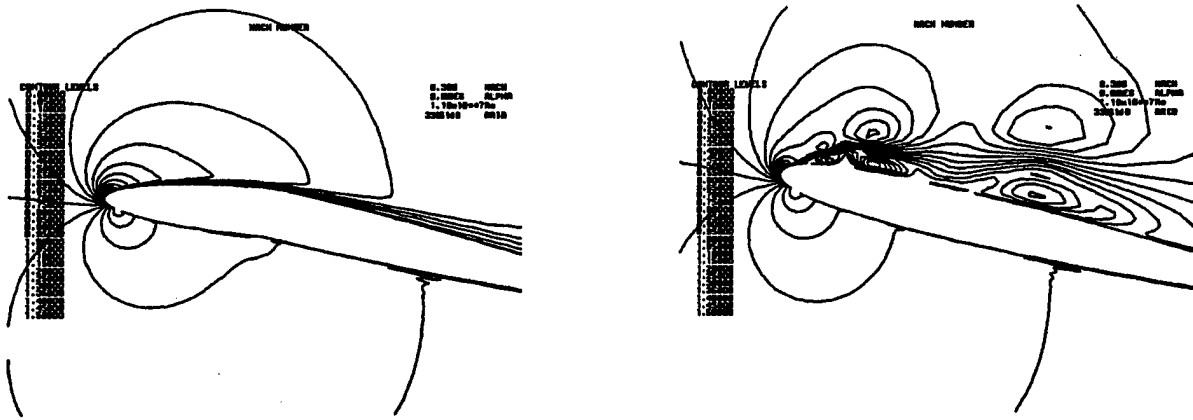

Figure 1: A view of the actuator as it will appear when mounted in the blade section. The leading-edge cap has been removed so that the actuator is visible, and the components have been labeled.

freestream Mach number is 0.3 and the reduced frequency is 0.10 (typical one per rev.). The airfoil is undergoing harmonic oscillation between 0 and 17 degrees. The baseline airfoil (NACA0009) begins to stall at about 16 degrees angle of attack, while the airfoil with dynamic leading-edge droop (approximately 8 degrees downward at the maximum angle of attack remains attached throughout the oscillation.



No Dynamic Stall

Dynamic Stall

Figure 2: Periodic Oscillation: NACA0009 with/without dynamically drooping leading-edge region.

Development and testing of the piezo-stack driven actuator has continued during the past year: the actuator components have been built and assembled and initial *in vitro* tests have been conducted. Currently, the actuator is generating deflections of just over 1 degree. The design is being modified based upon experimental evidence to minimize actuation losses. It is hoped that such improvements may enable deflections of approximately 4 degrees.

During the past year the code has been validated with AGARD experimental test cases and provides reasonable correlation of the unsteady lift and moments. The deflection point location and angle have been carefully studied; as a result the best location for the leading-edge droop deflection point was found to be the quarter chord location. If the deflection point is moved forward it gradually becomes unable to overcome the dynamic stall; if it is moved aft then it acts too much like a trailing-edge flap and produces unacceptable losses in lift and large pitching moments. Also the amount of maximum deflection angle required to alleviate dynamic stall has been investigated over a wide range of maximum angle of attack as well as Mach numbers between 0.2 and 0.4 for a NACA0012 airfoil. The resulting stall chart is shown in Figure 3. Typically a deflection angle of 5° provides attached flow for 2° higher angle of attack while the attainment of 10° deflection should provide attached flow for approximately 4° higher angle of attack.

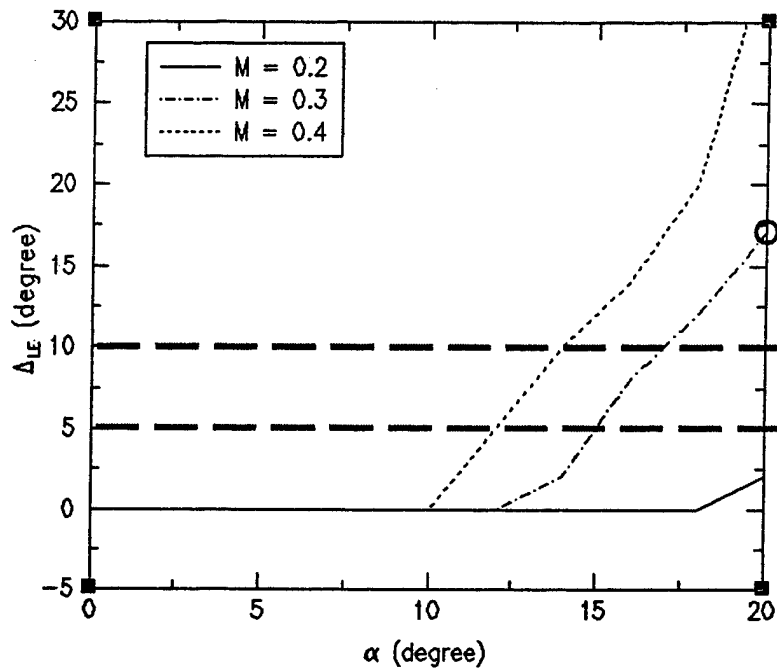

Figure 3: Stall chart for NACA0012 with/without dynamically drooping leading-edge region.

Furthermore, computational simulations indicate that the leading-edge droop only needs to be applied during one-half of the oscillation; this indicates that on a rotor blade the dynamic drooping should only be needed on the retreating side to alleviate the dynamic stall and will not be needed on the advancing side where adverse effects might be caused by the drooping leading-edge.

Future Work

The CFD code will be combined with an active control system to dynamically adapt the leading-edge droop to suppress dynamic stall. The suitability of dynamic leading-edge droop to reduce BVI noise will also be determined. Further experimental work is focused on improving actuator performance and then testing the actuator under aerodynamic loads. Once the actuator is performing well *in vitro*, it will be integrated into a blade section for tests under aerodynamic load. Initially, these tests will be conducted in a free-jet wind tunnel. If the actuator performs well there, it may also be tested at higher Reynolds Numbers in the Glenn L. Martin wind tunnel.

Significance

This research will explore and demonstrate the feasibility of using smart leading-edge droop for active rotor noise reduction, and is an important step in convincing helicopter manufactures that thinner airfoils can be used in the tip region without inducing flow separation on the retreating side. It is expected that such an active noise control system may reduce thickness noise by 3dB and HSI noise by 6dB without compromising other aspects of the rotor design. Already leading-edge droop calculations indicate that a NACA0012 airfoil will dynamically stall at approximately 4° higher angle of attack with 10° of dynamic droop and 2° higher angle of attack with 5° of dynamic droop.

External Collaboration

Experiments and CFD calculations will be performed in consultation with Army/Ames (Yung Yu, Chee Tung, Ken McAlister, Larry Carr) and NASA Langley (Ken Brentner). Active collaboration will be sought with MDHS (Ram Janakiram), UTRC (Jack Landgrebe), and Sikorsky (Bob Moffitt) as well as Chandrasekhra with the Naval Postgraduate School and Ted Meadowcroft at Boeing Philadelphia and Jim Narramore at Bell Helicopter.

Task 1.3

High Accuracy Wake and Vortex Simulations Using a Hybrid Euler / Discrete Vortex Method

Lyle N. Long and Nilay Sezer-Uzol
Rotorcraft Center of Excellence
The Pennsylvania State University
University Park, PA 16802
lnl@psu.edu

Research Objectives

A new approach has been developed which preserves vortices over long distances. This new hybrid Computational Fluid Dynamics / Discrete Vortex (CFD/DV) method couples a Lifting-Line/Free-Wake method with an unstructured grid, parallel 3-D finite volume CFD flow solver. The code will be used as a numerical wind tunnel. We will also extend the code to predict the wakes of rigid rotors in hover.

Approach

In the hybrid algorithm, it is assumed that the total solution field is composed of the potential flow solution from the Lifting-Line/Free-Wake code (Discrete Vortex solution) and the rest of the flow field. The modified Euler equations are then solved and the total solution field is obtained.

Accomplishments

We have implemented our new Hybrid CFD / Discrete Vortex Method in PUMA. The tip vortex and wake of a fixed wing is investigated as a starting point before attempting to simulate rigid rotor flow fields. Because it is important to show that the tip vortices are accurately captured far downstream and it is also necessary to demonstrate the effectiveness of the new algorithm to the simulation of vortical flows.

The inviscid computations are performed for a freestream Mach Number of 0.2 and for 5° angle of attack both with PUMA and with the Hybrid Method. A Runge-Kutta time integration method with Roe's numerical flux scheme is used. All cases are run on our parallel PC cluster COCOA (COst effective COmputing Array), consisting of 50 400 MHz Pentium II processors. This machine is extremely cost effective compared to parallel supercomputers. Runs for 6° angle of attack are also performed in order to be able to compare the results with the available experimental surface pressure data.

The solutions obtained with the hybrid method are compared to those without the hybrid method. The results show that the tip vortex shed from the wing tip is preserved over long distances when the hybrid CFD/DV method is applied. The wing tip vortex is quickly dissipated due to numerical diffusion in solutions with no hybrid method implementation.

Future Work

The ultimate goal will be to accurately simulate the wake hundreds of chords downstream. This method, the Hybrid CFD/DV method, will then be applied to the 3-D lifting rotor vortex/wake problem in hover (Caradonna and Tung rotor).

Significance

The U.S. Army (ARO) acknowledges the needs for research in this area in its BAA:

In contrast to fixed-wing aircraft, rotorcraft always operate under the influence of their own wakes. The prediction of rotor performance, vibratory loads, and blade-vortex interaction noise depends strongly on the accurate prediction of the rotor wake, and the prediction methodology of this wake remains one of the major challenges in fluid mechanics. New numerical algorithms or different techniques to increase accuracy and reduce the computational requirements are required.

The near field of helicopter and tiltrotor wakes are very *complex*, being *three dimensional*, *unsteady* and *nonlinear*. The rotor wake flow includes the *shedding of strong tip vortices* and the *interaction of these vortices with the rotor blades (BVI)*, and causes *vibration* and *noise*. The *accurate capture of vortical wake flows* is very important for the accurate prediction of *blade loading, rotorcraft performance, vibration, and acoustics*. It would be very desirable to build upon existing CFD codes and existing free-wake codes, to develop accurate BVI methods. The new Hybrid CFD / Discrete Vortex method does this.

External Collaboration

We have been very active in visiting industry and government sites. We have given presentations on this work at Sikorsky (Torok), Boeing Phil. (Ziegenbein), Boeing Mesa (Janakiram, Tadghighi), NASA/Army Ames (Strawn, Duque, Caradonna, and Yu), NASA Langley (Brentner, Farassat, Thomas, Jones), Navy PAX River (Kern & Bruner). We expect to work especially closely with NASA Ames and NASALangley on the vortex core comparisons.

Publications

- Chris Hall, M.S. Thesis, Dec., 1998
- AHS Forum 1999 Paper on Wakes and Vortices (Hall & Long)
- Nilay Sezer-Uzol, M.S. Thesis, Dec., 2000
- AIAA Aeroacoustics Conference 2000 Paper on Hybrid CFD/DV Method (Sezer-Uzol & Long)
- AIAA Aerospace Sciences Conference 2000 Paper on ParallelWopwop (Long & Brentner)

Task 1.4

Parameter Delineation, Directionality and Design

Fredric H. Schmitz Ben Wel-C. Sim
Alfred Gessow Rotorcraft Center
University of Maryland

Research Objectives

◆ The three major research objectives of task 1.4 are: (1) to examine, understand, and validate the generation, directionality, and design ramifications of reducing BVI noise through parametric variations. (2) to determine the modeling and operational requirements for the adaptation of active control devices to reduce helicopter noise. (3) to identify and examine the parameters of active control inputs necessary for effective reductions of external rotorcraft impulsive noise and to validate the effect of selected parameters through experimentation. Together, these objectives guide an integrated theoretical/experimental research program aimed at reducing impulsive helicopter BVI noise.

Approach

◆ Impulsive noise is one of rotorcraft's most challenging problems. Its interdisciplinary nature has led mathematical model builders in the direction of large comprehensive codes with the hope that the model has captured all of the relevant physics. Comparison with acoustic data has been mixed – with some researchers reporting good agreement while others have had only marginal success. Discrepancies between theory and experiment are blamed on many possible factors; from errors in the data gathering process to uncertainties in the fidelity of the modeling. Unfortunately, when comprehensive codes are used for impulsive noise prediction, it is often quite difficult to discern whether the basic physics of the problem are modeled adequately.

◆ This task takes a different tact. It employs a combined theoretical/experimental process that starts with low order modeling of the underlying physics of the impulsive noise process. Experiments are designed to check key aspects of the theory with one of the main objectives being to develop a basic understanding of the impulsive noise problem. Modeling sophistication is only added, if needed, to capture relevant missing physics. Non-dimensional parametric changes, modeling resolution, and active control schemes to reduce impulsive noise are first tried in this reduced order modeling approach to assess their effectiveness in reducing rotorcraft impulsive noise. When validated, these improved models can then be incorporated into comprehensive prediction methods.

Accomplishments

◆ There have been three major efforts under this task for the past year: (1) the application of simplified models to explore the near-field/far-field propagation of BVI noise for adequate indoor measurements, (2) the assessment of acoustic phasing on the radiation efficiencies of BVI, (3) the continued development of experimental facilities with up-to-date findings. A fourth effort – an assessment of the effectiveness of using active flaps and pitching to control impulsive noise, is reported under Task 1.1.

◆ Simplified models, previously developed to predict the gross features (directionality and design ramifications) of BVI noise of the two-bladed AH-1 helicopter, have been applied to assess the sound propagation characteristics of the highly non-compact and impulsive BVI mechanisms (Figure 1). This work is important as it directly affects the quality of indoor noise measurements if the microphones are positioned too close to the rotor (in the near-field). While the general understanding of the near-field is approximately one blade radius away (hub-centered), this is found not to be true for some of the BVI with high impulsive content and rapidly accelerating/decelerating trace Mach numbers. A new coordinate center, chosen based on the effective location of the BVI occurrence, was defined for this purpose to better represent the directionality and propagation of the BVI noise. With this new event-centered coordinate system, some BVI were found to display non-inverse square propagation (due to near-field and noise focusing effects) up to two rotor blade radius away. Depending on the characteristics and location of the BVI, this stipulates at least a three-blade radius measurement space (with respect to the hub) in order to capture the true far-field BVI noise and directivity.

◆ The second effort under this task highlighted the importance of acoustic phasing on the radiation strength and directionality of BVI noise. Formulation of the BVI problem was restricted to a constant strength, epi-cycloid tip-vortex shed wake system that was confined to a plane parallel to the tip-path-plane at a fixed distance below the rotor. The resulting equations, when solved without the variability of the wake miss distances, yielded quasi-steady estimates of the response of each blade to this shed vortex system, which, when summed over each interaction give estimates of BVI acoustic efficiency. When categorized according to their trace Mach number properties, BVI with accelerating supersonic trace Mach numbers inboard (Type "β") and infinite trace Mach numbers (parallel, Type "γ") were found to have the strongest phasing and noise radiation efficiency. These characteristic phasing

and trace Mach numbers were shown to directly govern the directionality as well. While most of the active controlled methodologies in the MURI have geared towards negating the source strengths, this current effort suggests that the efficiency of the BVI noise radiation process can be reduced by appropriately controlling the acoustic phasing.

- ◆ Progress from the third effort is slowed and constrained somewhat by a lack of funding. A novel experimental approach that investigates key governing parameters of BVI noise by simulating the scaled BVI geometry and test conditions with a Blade-Controlled Disturbance-Interaction (B-CD-I) gust encounter is still being pursued. Current plans are to perform the B-CD-I experiment in the State-of-Maryland Anechoic Rotor Test (SMART) facility under carefully controlled conditions. With the progress made in the theoretical study of BVI noise radiation and measurements (effort 1), the size of the SMART facility is deemed adequate for this proposed BVI simulation. Additional acoustic treatment is required to treat strategic locations where noise reflections are likely to contaminate acoustic measurements. Construction of the gust generator (supported by limited internal resources) is currently in progress with emphasis on the different curved exhaust designs to simulate the curvature of the different BVI interaction types (effort 2). An existing 7-foot diameter rigid rotor blade system (provided by the Army), together with a University's modified drive system, will be used to power the rotor for the B-CD-I experiment. The use of these existing blades and drive system will help minimize costs.

Future Work

- ◆ The use of our simple modeling approach to explore the effects of parameter design changes on BVI noise radiation will be extended to multiple-bladed rotors. In particular, the effects of hover tip Mach number, advance ratio and their near-field/far-field relationships will be explored to see how BVI acoustic energy is radiated.

- ◆ We will also begin to take a more fundamental look at the unsteady BVI aerodynamics and the potential coupling between the aerodynamic disturbance field and the radiated acoustics. Both the simple models and the more comprehensive CFD model will be used for guidance and evaluation of a restricted problem set to capture the unsteady aerodynamic and acoustic events.

- ◆ Implications of BVI noise directivity on microphone placement in wind tunnels will be explored this year through an invitation to participate in the NASA's UH-60 rotor test. A study of the various BVI encounters and their radiation characteristics will be made and compared to existing measured data. Changes to these measurement positions will then be suggested to ensure that the vital BVI noise field is being captured in the Ames 40x80 wind tunnel. A similar effort will be carried out for the HART II test scheduled in the DNW next year.

- ◆ Research over this past year has given us more confidence in the "B-CD-I" approach. Restricting the number of governing BVI parameters through a more focused investigation of BVI aerodynamics and acoustics should give us more insight and understanding - which can lead to promising methods of noise control. To this end, we will fabricate and calibrate the BVI gust generator this year. The design will be modified slightly to make the apparatus portable so that it may be used in other anechoic facilities. Unfortunately, lack of funding for the completion of the SMART facility, rotor test stand and the acquisition of measurement system will restrict progress on this part of Task 1.4.

- ◆ In the out-years (2001, 2002), when the SMART facility, the gust generator and the rotor drive become operational, they will be used to evaluate key aspects and improve the understanding of the impulsive noise modeling process. This testing approach will also enable the facility to become a cost-effective test-bed for experimental validation of active and passive control technologies.

Significance

- ◆ Impulsive noise continues to be one of the limiting factors for rotorcraft commercial and military operations. The research results from this task will lead to a better understanding of governing impulsive noise mechanisms and their control. It will also explore the practicality and effectiveness of using passive and active control for external noise suppression. The novel B-CD-I experimental approach should provide the technical community with a unique way of evaluating the response of rotating blades to unsteady, controllable disturbances while at the same time provide a quantitative measurement of the radiated acoustic field.

- ◆ This year's research has been particularly significant. Results from our simple BVI modeling approach has shown that the non-compactness of BVI generates varying degree of noise focusing in the near-field. The net effect is a greater distance (from the rotor hub) required for capturing the true far-field BVI noise and directivity characteristics. Also of significance is the role of acoustic phasing which is delineated through a study of the BVI radiation efficiencies. Results-to-date indicate a strong amplification of noise due to phasing and suggest the likelihood of reducing BVI noise through controlling the phased (spatial and temporal) emissions of sound from BVI interactions.

External Collaboration

This work is closely coordinated with NRTC (Y. Yu), NASA Langley (T. Brooks, M. Marcolini, D. Connor) and NASA Ames (G. Yamauchi, C. Tung, M. McCluer, C. Kitaplioglu). Findings-to-date will be used to facilitate the noise measurement of the UH-60 rotor at NASA Ames 40x80 tunnel this Fall. Collaborations with the National Aerospace Laboratory, Japan (S. Saito and T. Aoyama) for further theoretical studies is also currently underway. In addition, C. Keys and P. Ziegerbein of Boeing-Philadelphia and B. Edwards of Bell Helicopters have also expressed interest in this task.

Publications

1. Schmitz, F. H. and Sim, B. W.-C., "Radiation and Directionality Characteristics of Advancing Side Blade-Vortex Interaction (BVI) Noise," Presented at the 6th AIAA/CEAS Aeroacoustics Conference, Lahaina, Hawaii, June 2000.
2. Sim, B. W.-C., Schmitz, F. H. and Aoyama, T., "Near/Far-Field Radiation Characteristics of Advancing Side Helicopter Blade-Vortex Interaction (BVI) Noise," Presented at the American Helicopter Society 56th Annual National Forum, Virginia Beach, Virginia, May 2000.

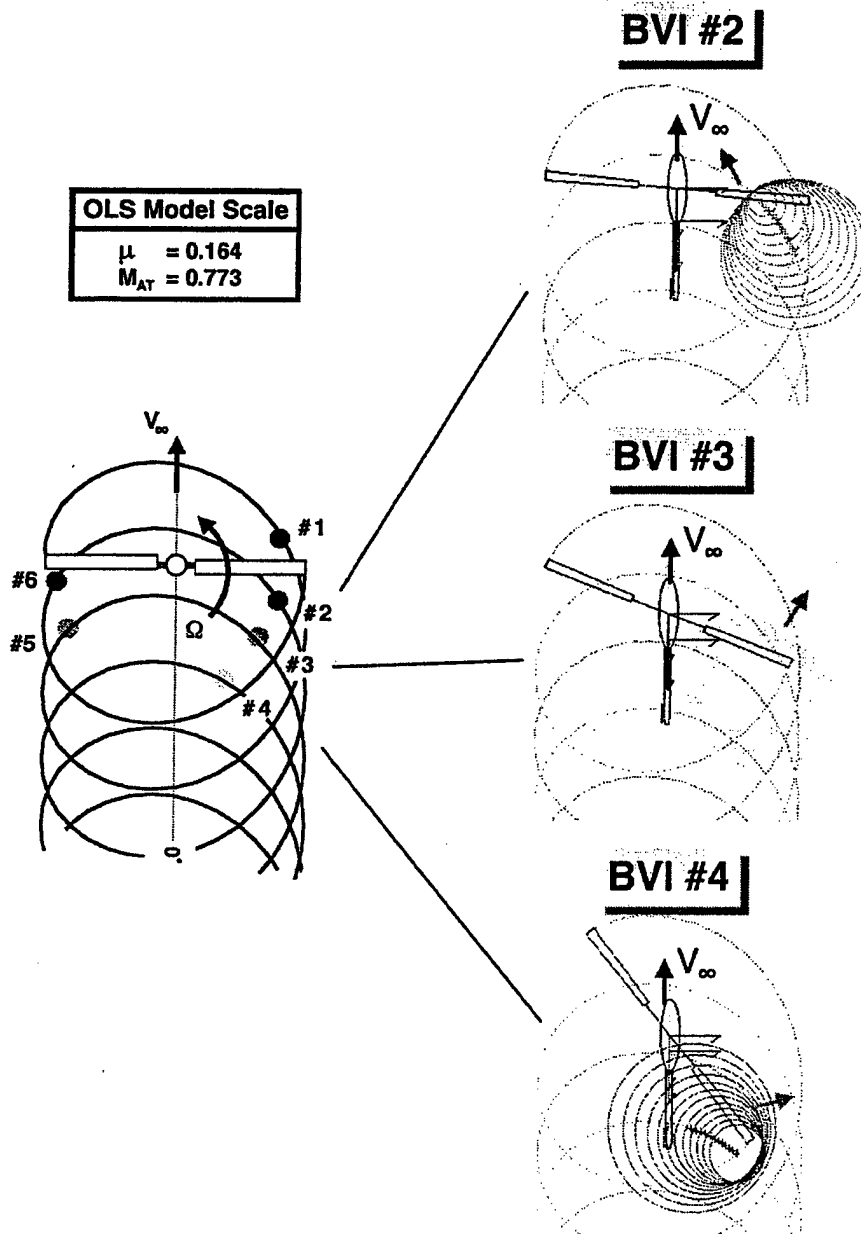

Figure 1. Radiation of acoustic waves from different BVI interactions. Intense phasing is indicated by regions where the acoustic waves intersect each other.

Active Attitude Modification for BVI Noise Abatement
Task 1.5

A. R. George
Cornell University

J. Abelló
Cornell University

Research Objective

To perform a comprehensive analysis to investigate the use of added longitudinal forces (thrust/drag), vertical forces (lift/downforce) and changes in glide path angle to actively modify the attitude and wake geometry of a rotorcraft in order to reduce blade - vortex interactions (BVI) and their resulting noise and vibration.

Approach

This sub-task is investigating the application of added longitudinal forces (thrust/drag), vertical forces (lift/downforce), or descent angle changes to actively modify the attitude (thrust coefficient and tip path plane angle) of rotorcraft in order to achieve control of the mean inflow through the rotor and thus the miss distance of the blade-vortex interactions. The force devices could be existing components (as a stabilator or the wings on a tilt rotor aircraft) or additional devices (as drag brakes or thrusters). They would be actively controlled or deployed during descent and other operations which would otherwise generate substantial BVI noise. Both helicopters and tiltrotors have been considered in our analysis.

In the first phase of this subtask, simplified trim, aerodynamic and aeroacoustic analysis were implemented to include added forces and changes in descent angle in order to determine the resulting changes in rotor operating conditions, wake, and BVI. Both helicopters and tiltrotors were considered. Empirical data on BVI noise as a function of thrust coefficient, advance ratio and tip path plane angle (from BO-105 scaled rotors and other experiments) was used to evaluate changes in BVI noise. For the second phase of our subtask, we are developing more sophisticated aerodynamic and aeroacoustic models to further estimate the differences in noise with and without force and glideslope angle variations and to extend the results obtained above. Analysis has been previously carried out to determine the size of the required force devices depending on rotorcraft weight and flight speed, and studies to determine optimum added force device placement for minimum adverse fuselage tilt are being completed. Our analysis will yield control requirements and strategies for BVI suppression.

Accomplishments

Our research has shown that longitudinal added forces (thrust, drag) are more efficient than vertical forces (lift, negative lift) in modifying TPP angle for both helicopters and tiltrotors. For a given added force, the resulting change in \square_{TPP} increased as the fraction of tiltrotor weight carried by the wing increased; thus the added force concept seems more attractive for tiltrotors than for helicopters, especially since the existing control surfaces on the tiltrotor can be used to generate the desired added forces. It is of special interest to study the effects of these added forces on fuselage attitude, and simple aerodynamics and trim analyses are being developed for this end. These analyses will yield constraints for added force magnitude as well as for force device placement, and will indicate optimum locations for minimum adverse changes in fuselage inclination angle (figure 1).

We have also shown that descent angle changes produce a similar effect on tip path plane angle as longitudinal forces, thus they represent a promising alternative to modify TPP angle for cases where flight regulations do not constrain glideslope angle or where using added forces is not a feasible alternative. The general behavior of change in TPP angle caused by changing descent angle is comparable for helicopters and tiltrotors, with the corresponding change in \square_{TPP} caused by a given change in descent angle increasing with decreasing wing lift. Our efforts have then shown that using added forces is a more promising concept for tiltrotors landing at higher values of wing lift, whereas changes in descent angle seem more practical for helicopters if operations allow such flexibility.

Preliminary results have shown substantial promise for varying rotorcraft configuration and flight parameters to reduce BVI noise for overflight and approach conditions; experimental results obtained by Burley and Martin for a scaled BO-105 rotor (see references) indicate a general trend of 2 dB BVI sound pressure level reduction per degree of change in \square_{TPP} for a given value of advance ratio. We are currently developing more sophisticated aerodynamic and aeroacoustic computational models to better predict and identify trends on both BVI noise intensity and directionality under the influence of added forces and changes in glideslope angle. Starting with rigid, prescribed or fixed representations of the wake and its resulting effect on quasi-steady blade loading, the collapsing sphere concept is employed to find the acoustic planforms in space and later the acoustic pressure due to loading noise at the observer location. This strategy allows to calculate the (observer) time history of acoustic pressure at any observer location in space, thus allowing the investigation of changes in TPP angle on BVI noise intensity and directionality (figure 2).

Future Work

An important part of this research task is to develop a comprehensive analysis in order to accurately include the force devices and different approach angles for acoustic studies. In this respect, we plan to integrate our aeroacoustic model with our trim model to yield an integrated tool which will allow us to propose flight and attitude strategies for BVI reduction. Experimental results for a wider range of flight conditions to be kindly provided by Dr. Casey Burley (NASA-Langley) will be used both to extend our current empirical BVI change model and to establish comparisons with our computational model, which will allow us to consider the changes in BVI magnitude and directionality when added forces or changes in glideslope angle are applied. This information will ultimately be used to formulate an adaptive control strategy to actively modify the attitude of the rotor system for noise reduction under time-varying flight conditions, and to perform control studies for noise abatement with constraints.

We will perform a parametric study to determine the size, placement, configuration and control requirements of the added force devices for effective BVI noise reduction. Results from our moment trim studies will establish constraints in device placement for minimum adverse handling effects such as pronounced levels of fuselage tilt. Other practicality and feasibility issues such as safety, power consumption and performance will be further investigated as well.

Significance

The results of this task will address the feasibility of employing force control devices and glide path angle changes in reducing BVI noise. This task will also lead to more refined design, control and prediction methodologies for the active suppression of BVI by using rotor force, configuration and glideslope control.

External Collaboration

Collaboration has included Fred Schmitz and Ben W.-C. Sim (University of Maryland). Valuable input has been received from Casey Burley and David Conner (NASA-Langley), Hanno Heller (DLR), Ram Janakiram (Boeing-Mesa) and V.T. Nagaraj (University of Maryland).

Publications and Technology Transfer

Abelló, J.C. and George, A.R. "Rotorcraft BVI Noise by Attitude Modification," Presented at the 5th AIAA/CEAS Aeroacoustics Conference. Bellevue (Greater Seattle), May 10-12, 1999. AIAA 99-1931

References

- Abelló, J.C. and George, A.R., "Rotorcraft BVI Noise Reduction by Attitude Modification," Presented at the 5th AIAA/CEAS Aeroacoustics Conference. Bellevue (Greater Seattle), May 10-12, 1999. AIAA 99-1931
- Burley, C. L. and Martin, R. M., "Tip-Path Plane Angle Effects on Rotor Blade-Vortex Interaction Noise Levels and Directivity," presented at the 44th Annual Forum of the American Helicopter Society, Washington DC, June 1988.
- Chehab, M. and Wolk, J., "A Windtunnel Study of X-Force Generators to Reduce Helicopter Blade-Vortex Interaction (BVI) Noise", Presented at the 2000 AIAA Student Design Conference.
- Schmitz, F. H., "Reduction of Blade-Vortex Interaction (BVI) Noise through X-Force Control," Journal of the American Helicopter Society, Vol. 43, No. 1, January 1998, pp14-24.
- Schmitz, F. H. and Sim, B.W.-C., "Radiation and Directionality Characteristics of Advancing side Blade-Vortex Interaction (BVI) Noise," Presented at the 6th AIAA/CEAS Aeroacoustics Conference. Lahaina, Hawaii, June 12-14, 2000. AIAA 2000-1922
- Sim, B.W.-C., George, A.R. and Yen, S.J., "Blade-Vortex Interaction Noise Directivity Studies using Trace Mach Number", Presented at the American Helicopter Society Second Aeromechanics Specialists Meeting, Bridgeport, Connecticut, October 1995.

Selected Figures

added drag equal to 5% of W for -6 deg descent at 50 knots

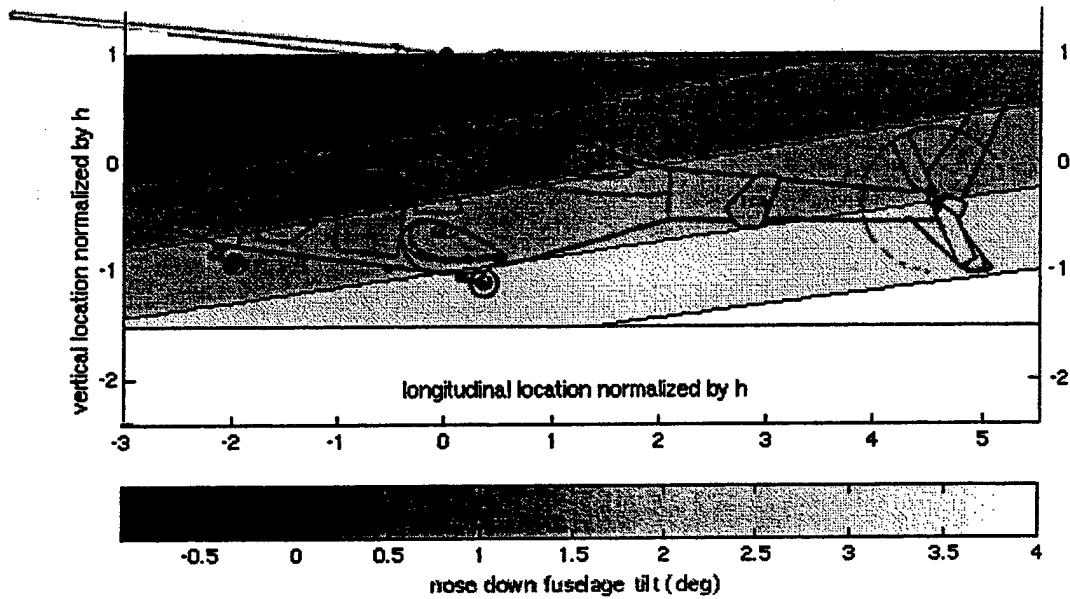

Figure 1: Fuselage tilt (degrees, nose down) as a function of added drag device location (non-dimensionalized by the distance h between hub and center of gravity, measured along shaft axis). This figure corresponds to a Bell 222B helicopter, which is inscribed in the contour plots to scale. For a given fuselage location of an added drag device generating a drag force equal to 5% of helicopter weight, the contours indicate the resulting nose-down fuselage tilt in degrees for the above descent flight conditions. Notice that fuselage tilt due to added drag depends much more strongly on the vertical location of the drag device than on its longitudinal location; the opposite is observed for the case of added lift, which generates a fuselage tilt of comparable magnitude but a much smaller change in TPP angle.

An added drag force equal to 5% of helicopter weight is capable of tilting the TPP by 2.8 degrees nose down with respect to the initial value.

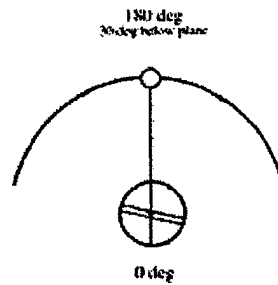
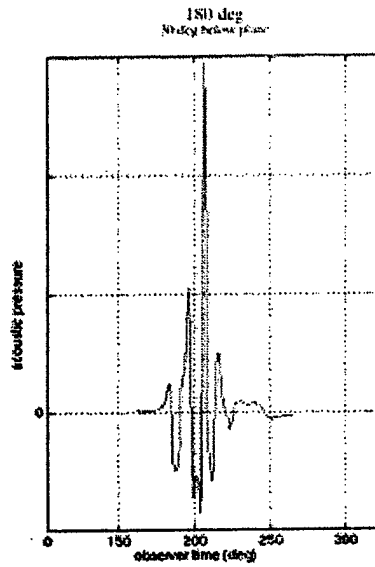

Figure 2: BVI pulse time history for an observer at 180 degrees azimuth and 30 degrees below the plane of the rotor. This data was obtained for a 2-bladed rotor operating at .664 hover tip Mach number, .164 advance ratio and 2 degrees TPP angle. Rotor radius is 3.143 ft, blade chord is .341 ft, and the rotor is located initially 3.4 radii away from the observer. Wake is modeled as fixed, and vortex core radius equals 5% of blade chord.

TASK 2.1

Interior Noise Control Using Smart Materials

M. Al-Bassiyouni and B. Balachandran
Department of Mechanical Engineering
University of Maryland
College Park, MD 20742-3035

Research Objectives

The overall aim of this task is to help in the development of viable active materials based control schemes for reducing rotorcraft interior noise. Specific objectives include the following: a) development and validation of structural-acoustic models and b) investigations into non-model based and model based control schemes for creating multiple quiet zones.

Approach

A combined experimental and analytical investigation into the use of piezoelectric materials on a flexible panel to control transmission of multiple tones through this panel into a three-dimensional enclosure is conducted. The multiple tones considered are in a bandwidth of 40 Hz to 1000 Hz. Lead Zirconate Titanate (PZT) patch pairs, which are bonded symmetrically on the flexible panel, are used as actuators, while a combination of microphones and Polyvinylidene Fluoride (PVDF) films are used as sensors. Influence of piezoelectric nonlinearities are examined analytically, and validated through simulations and experiment (Figures 1--3). Experimental identification of the structural-acoustic system is carried out to implement an approximate zero-spillover control scheme (Figure 4) for spatially local interior noise control. Actuator grouping and actuator-sensor pairing are also to be investigated on the basis of this control scheme.

Accomplishments

Extensive analytical and experimental studies of spatially local noise control of disturbance with multiple tones have been conducted and it has been demonstrated that actuator grouping can be beneficial for local noise control. Through the experiments, it has been demonstrated that nonlinearities associated with piezoelectric actuation can lead to higher harmonics in the response and pose problems for realizing local noise control. A mechanics based model inclusive of piezoelectric actuator nonlinearities and plate nonlinear elasticity effects has been developed. Through the use of this model and through experiments, it has been demonstrated that actuator nonlinearities can be significant beyond certain electric field strength limits (Figures 2 and 3). In order to operate the actuators in a linear regime, actuator grouping is used and an approximate zero-spillover control scheme is being considered. Appropriate reference and error sensor locations have been identified to construct this control scheme.

Future work

Future work will include the following: (a) extension of zero-spillover control scheme to multi-input multi-output (MIMO) case, (b) choice of actuator grouping and actuator-sensor pairing to realize zero-spillover controller, and (c) experimental studies inside helicopter cabin with Professor A. Baz.

Significance

The outcome of this task will be useful for assessing the viability of active materials based schemes for controlling multiple tones in a three-dimensional enclosure such as a rotorcraft cabin.

External Collaboration and Interactions

Collaborative activity with Scientific Systems Company, Inc. (Dr. Raman Mehra) focused on using a model-based frequency weighted LQG control scheme for digital, local noise control. Discussions were also carried out with Mr. Chris Park of United Technologies Research Center, Dr. Richard Silcox of NASA (Langley), and Professor Chris Fuller of VPI&SU. A presentation on active vibration and acoustics control was also made at Caterpillar, IL.

Publications

B. Balachandran, *Active Control of Interior Acoustics*, Proceedings of International Conference on Smart Materials, Structures and Systems, Bangalore, India, July 1999, pp. 403-409

B. Balachandran and M.X. Zhao, *Actuator Nonlinearities in Interior Acoustics Control*, Proceedings of the SPIE's 7th International Symposium on Smart Structures and Materials, California, March 2000, Paper No. 3984-13.

M. Al-Bassyiouni and B. Balachandran, *Zero Spillover Control of Enclosed Sound Fields*, Abstract submitted to SPIE's 8th Annual International Symposium on Smart Structures and Materials, California, March 2001.

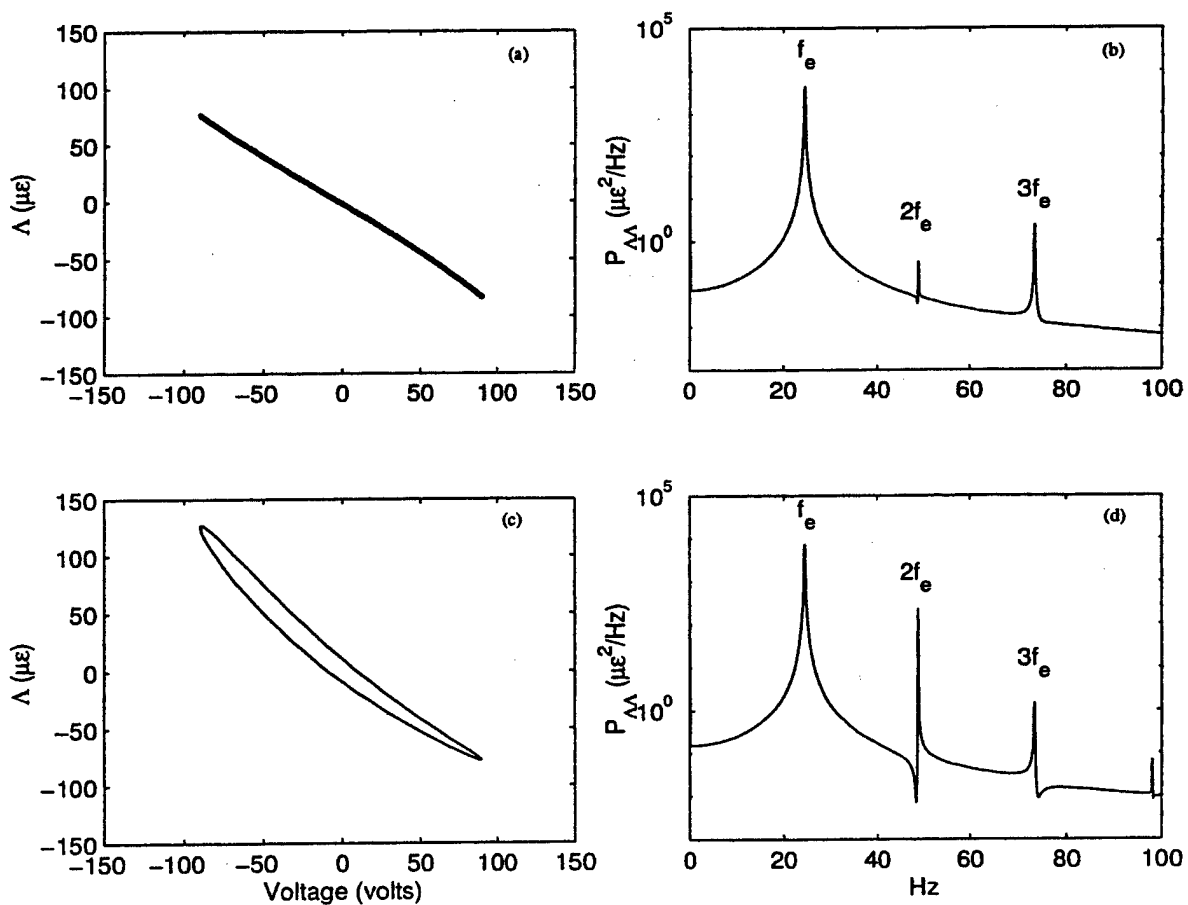

Figure 1. Free strain behavior from models without and with hysteresis effects: (a) free strain versus voltage input (without hysteresis effect), (b) power spectrum in the absence of hysteresis effect, (c) free strain versus voltage input (with hysteresis effect), and (d) power spectrum in the presence of hysteresis effect.

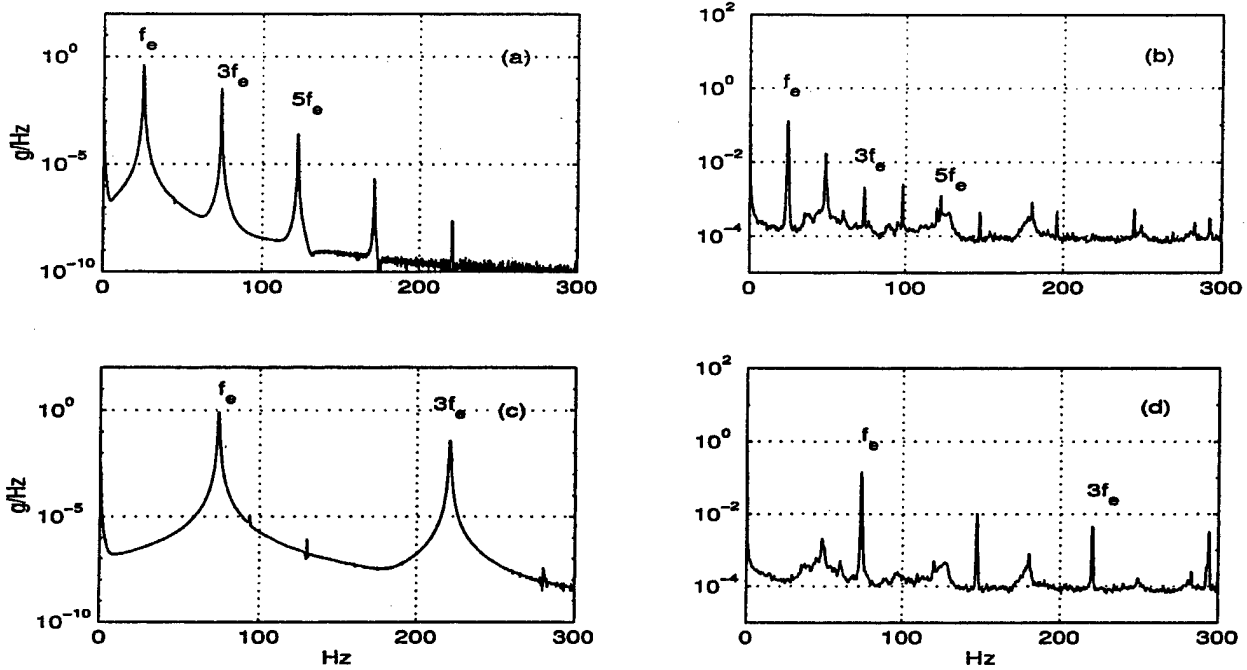

Figure 2. Spectra of plate acceleration responses to harmonic excitations: (a) excitation frequency $f_e = 24.5$ Hz, numerical simulation, (b) excitation frequency $f_e = 24.5$ Hz, experimental measurement, (c) excitation frequency $f_e = 73.5$ Hz, numerical simulation, and (d) excitation frequency $f_e = 73.5$ Hz, experimental measurement.

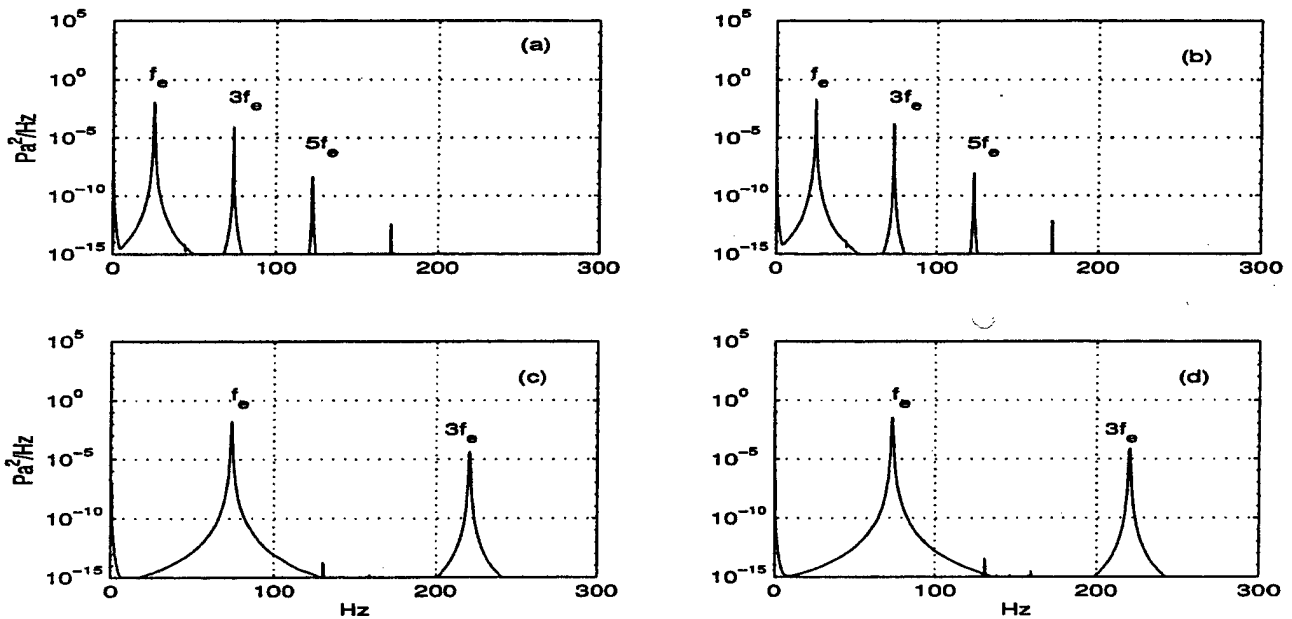

Figure 3. Spectra of acoustic responses: (a) excitation frequency $f_e = 24.5$ Hz, pressure field three inches below panel, (b) excitation frequency $f_e = 24.5$ Hz, pressure field five inches below panel, (c) excitation frequency $f_e = 73.5$ Hz, pressure field three inches below panel, and (d) excitation frequency $f_e = 73.5$ Hz, pressure field five inches below panel.

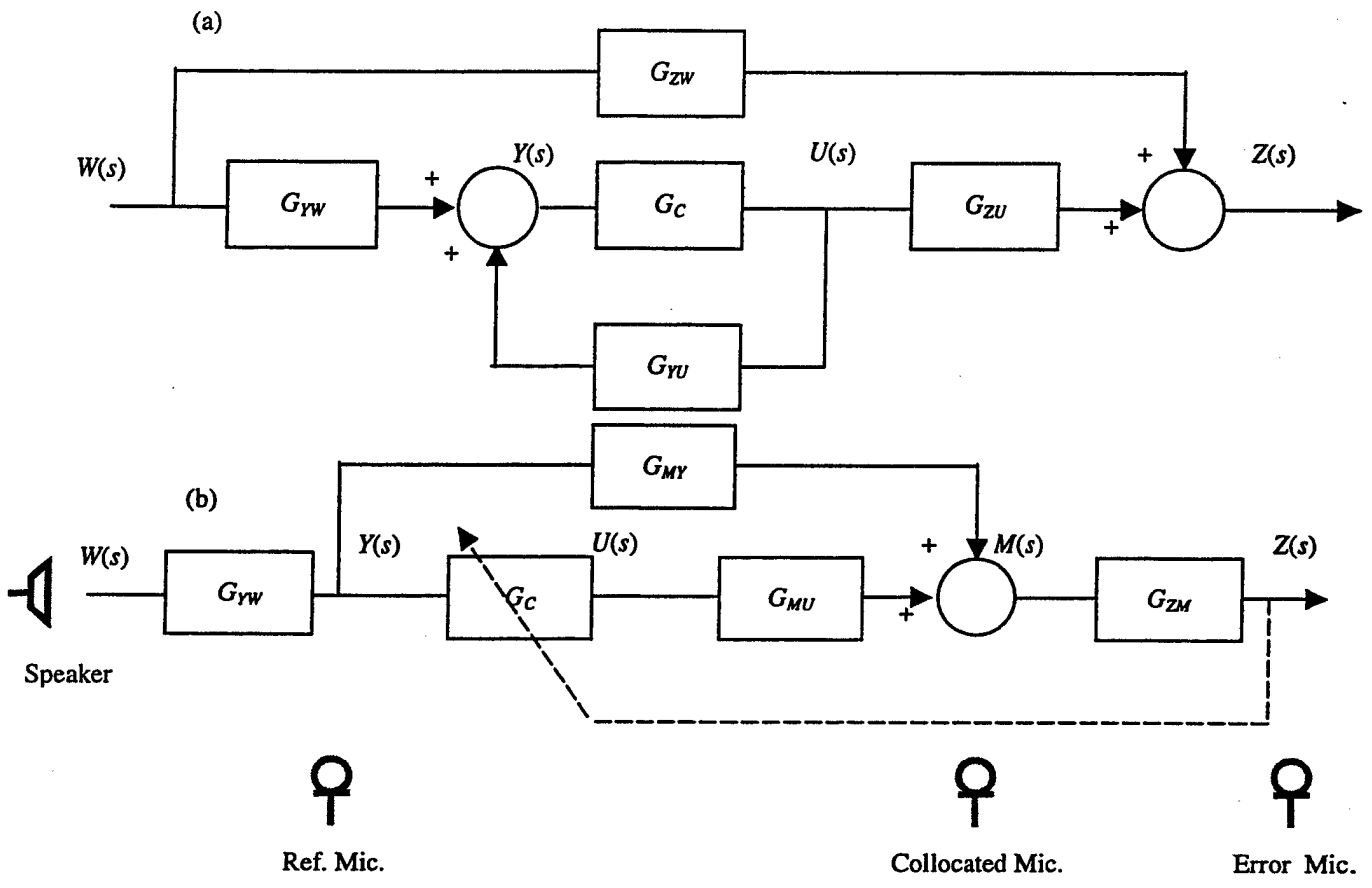

Figure 4. Zero-spillover control scheme: (a) general ANC scheme and (b) modified scheme for ASAC.

Task 2.2 - Hybrid Active / Passive Trim Panel Damping Control

Gang Wang
Graduate Research Assistant
Alfred Gessow Rotorcraft Center
University of Maryland

Norman M. Wereley
Associate Professor
Alfred Gessow Rotorcraft Center
University of Maryland

Research Objective

We will explore the potential of hybrid active/passive damping control of trim panels and other metallic/composite fuselage structural components to control interior cabin noise. The active panel control will be used to control the low frequency band (< 300 Hz) and the passive damping will be used to mitigate the high frequency noise (> 300 Hz).

Approach

We will develop an active / passive hybrid approach to control interior acoustics and structurally radiated sound using a smart trim panel fabricated from composite material. Stability and performance robustness will be enhanced via passive damping using constrained layer damping, thereby improving overall noise cancellation performance. Damping augmentation via passive and active constrained layer damping treatments will be examined. Improved high fidelity structural trim panel models will be developed that account for composite materials (such as kevlar/epoxy), boundary conditions, shear lag damping, compressional damping, and deviations from idealized Kirchoff plate theory. Active control of the panel for noise reduction will be accomplished using piezoactuators, either surface bonded or embedded in the elastic layers of the sandwich structure. Multivariable feedforward and feedback techniques will be developed to maximize noise cancellation performance. We will optimize the number and placement of actuators, active/passive constrained layer damping treatments, and sensors, on trim panels and other fuselage structural components using refined algorithms already developed in Task 2.1.

Accomplishments

During Year 1, we had completed a preliminary Galerkin analysis for a sandwich plate with a viscoelastic core and isotropic (aluminum) face plates, and performed an experimental validation. The primary result from the first year's effort was to illustrate the importance of accounting for the frequency dependence for the complex modulus of the viscoelastic core. The frequency dependence of the viscoelastic core was accounted for using the Golla-Hughes McTavish method described in Ref. 1. In the GHM method, internal dissipation coordinates are added to the model to account for the frequency dependent complex modulus of the viscoelastic material. Plates were fabricated that were nominally 1/16 inch in thickness with a viscoelastic core (3M ISD 112) of 2 mil, 5 mil, and 10 mil thickness. These plates were tested on an aluminum plate clamping fixture using piezo-actuators for modal excitation. Excellent agreement was obtained, with error in the natural frequencies generally lower than 5% in the frequency range < 200 Hz. This work was published in the *ASME Journal of Vibration and Acoustics* (Ref. 2).

The focus of year 2 and 3 was to improve the modeling of the sandwich plate with an emphasis on improving the modeling of the frequency response due piezo-actuators. The first step was to examine a 1D structure (i.e., a beam) as opposed to the more complex 2D structure (i.e., plate), and to develop, and experimentally validate, a beam analysis methodology. Galerkin assumed modes and conventional FEM analyses were developed, and are the subject of Ref 3. The drawback of these methods, even when using the Golla-Hughes-McTavish method or other internal dissipation methods, is the high number of degrees

of freedom required to accurately model the passively damped structures. Thus, a spectral finite element model (SFEM) was developed for modeling the active piezo-actuated sandwich beam. SFEM is discussed in Ref. 4 for isotropic structures. In this effort, we are developing an SFEM analysis for a passively damped structure, such as beams and plates with a viscoelastic core. The advantage of SFEM is that very few elements (typically corresponding to the small changes in impedance associated with adding a piezo-actuator) are required to accurately model the frequency response. A second advantage of the SFEM analysis is that no additional internal coordinates are needed to account for the frequency dependent complex modulus of the viscoelastic material. Thus, the order of the SFEM model is low compared to a conventional FEM or Galerkin assumed modes analysis. The sandwich beam model has been successfully validated experimentally in a low frequency range (<300 Hz), and additional testing of higher frequency behavior (< 1000 Hz). The beam analysis results were submitted to the *ASME Journal of Vibration and Acoustics* (Ref. 5).

The focus of year 4 was to develop a higher order analysis for sandwich plates. The Kantorovich method (Ref. 6) was used to obtain the best possible mode shapes for both in-plane (membrane extension) and out-of-plane (plate bending) vibration of isotropic plates. The constants in the analytical expressions for both membrane and plate mode cases were calculated using the Kantorovich method. These identified plate and membrane mode shapes were applied to our sandwich plate analysis using the assumed modes Galerkin method. These improved plate and membrane mode shapes lead to a higher order method because fewer modes were needed to achieve comparable accuracy compared to more numbers of beam and rod mode shapes in previous analysis. We finish all the analytical works and compare to previous results.

Expected Future Accomplishments

Year 5: Complete experimental validation for sandwich plates. Extend results to orthotropic (composite) materials. Develop coupled structural-acoustic models for isotropic and orthotropic panels with induced strain actuation, and constrained layer damping on acoustic cavity. Validate analysis with test data. Fabricate scaled fuselage and incorporate damping treatments. Refine structural-acoustic models, and control strategies for dynamically scaled fuselage structures with damping treatments. Initiate anechoic chamber test for model and control strategy validation. Develop hybrid active/passive damping control strategy for controlling multiple tones and wide band noise. Optimize number and placement of actuators, sensors and damping treatments to obtain multiple quiet zones in dynamically-scaled fuselage. Test data from the anechoic chamber at Maryland will be used to validate models, and to verify predicted acoustic cancellation performance.

Significance

We will develop and test feasibility of hybrid smart composite trim panel with low frequency band active damping control via distributed piezo-actuation and passive damping layers, and high frequency band passive damping control.

External Collaboration and Technology Transfer/Liason

We will collaborate with government researchers at NASA/Langley (Richard Silcox), Army Langley (Danny Hoad) and Army/Ames (Bob Ormiston). Existing strong ties with Lord Corporation (Mark Jolly). Viscoelastic materials supplied by 3M Corporation (Greg Anderson).

References

1. Lam, M.J., D.J. Inman, and W.R. Saunders (1998). "Vibration Control Through Passive Constrained Layer Damping and Active Control." SPIE, Vol. 3045, Passive Damping and Isolation Conference.
2. G. Wang, S. Veeramani, and N.M. Wereley (2000). "Analysis of Sandwich Plates with Isotropic Face Plates and Viscoelastic Cores." Journal of Vibration and Acoustics, Vol 122, pp. 305-312.
3. G. Wang and N.M. Wereley (1998). "Frequency response analysis and measurement of beams with passively constrained damping layers and piezoactuators." SPIE Conference on Passive Damping and Isolation, 1-5 March, San Diego CA. Paper No. SPIE-3327-05.
4. J. Doyle (1997). *Wave Propagation in Structures*. Springer-Verlag.
5. G. Wang and N.M. Wereley (1999). "Spectral Finite Element Method for Wave Propagation in a Sandwich Beam Having Isotropic Face Plates and a Viscoelastic Core". AIAA Structures, Structural Dynamics, and Materials Conference, Paper No. AIAA-99-1540. St. Louis, MI. Submitted to *ASME Journal of Vibration and Acoustics*.
6. Kantorovich L. V. and Krylov V. I. (1964) *Approximate Methods of Higher Analysis*, Groningen, the Netherlands.

TASK 2.3 ACTIVE INTERIOR NOISE CONTROL USING ACTIVE PIEZOELECTRIC-DAMPING COMPOSITES

A. Baz

Mechanical Engineering Department, University of Maryland, College Park, MD 20742

Research Objective

The main objective of this task is to demonstrate, theoretically and experimentally, the feasibility of using Active Piezoelectric Damping Composites (APDC) in controlling the interior noise of rotorcraft cabins. Our specific objectives are: (a). developing finite element models to simulate the interaction between the structural-acoustics of the cabin and the dynamics of the APDC treatment and (b) experimentally evaluate the effectiveness of optimized configurations of the APDC treatment in controlling cabin noise.

Approach

Finite Element Model (FEM) will be developed to model the coupling between the dynamics of the cabin and the controls of the APDC patches. The FEM will predict the dynamics of the cabin walls and the sound pressure distribution for different control strategies. Optimal and adaptive LMS control strategies will be employed to generate the appropriate control actions. The physical properties of the damping core, the number and placement of the APDC patches will be optimized to ensure robust performance over desired frequency and temperature ranges. The FEM predictions will also be validated experimentally using a scaled rotorcraft model placed inside the University of Maryland anechoic chamber. The performance will be compared with conventional Passive Constrained Layer Damping (PCLD) treatments to determine the merits and limitations of the APDC treatment. Comparisons between the theoretical predictions of the FEM with the experimental results will be made to refine the developed FEM.

Accomplishments

1. A new class of a Dual-Function APDC is developed with obliquely embedded piezo-rods in order to simultaneously control the compressional and shear damping. The new APDC controls simultaneously the structural and acoustics modes when it is augmented with an active sound absorbing foam. The electromechanical coupling factors of the APDC are determined to optimize the inclination angles of the piezo-rods.
2. The electrical impedance-frequency characteristics of the APDC are modeled theoretically and validated experimentally with different orientation piezo-rods.
3. The hysteresis characteristics of the APDC are measured experimentally with piezo-rods oriented at 45 and 90 degrees at frequencies ranging from 100-2500Hz and activation voltages up to 200Volts.
4. A FEM is developed for a flexible panel/APDC system coupled with a box-type acoustic cavity with rigid walls. The performance of the system is evaluated theoretically and experimentally using a two APDC patches controlled by PD controllers. The effectiveness of the APDC with 90/45 deg. in controlling multi-modes has been demonstrated successfully as compared to the 90/90 deg configuration.
5. A FEM is developed for ATI-Ultraspport 496 helicopter cabin with PCLD. The model is validated experimentally and used to determine the areas of maximum strain energy to optimally place the PCLD patches. The vibration and interior acoustics are computed for different PCLD patch configurations. Considerable attenuation is obtained with patches placed on doors, bottom and front shield. The FEM predictions are validated experimentally.

Future Work

We expect to develop an effective the Dual-Function APDC treatment to control the vibration and interior noise of rotorcraft cabins.

Year 5: Optimize the design of the Dual-Function APDC patches and use the optimized patches to control the vibration and interior noise of the ATI helicopter cabin. Compare experiments with theory.

Significance

This research activity will demonstrate the feasibility of using the Dual-Function APDC treatment in attenuating structural vibration and noise radiation inside rotorcraft cabins. Hence, improved fatigue life, communication and comfort are expected for both military and civilian rotorcrafts.

External Collaboration and Technology Transfer

Interactions will be made with the Naval Research Lab. (Drs. Brian Houston, Peter Herdic and Peter Matic) where the APDC is used to control high frequency vibration and exterior noise of submersibles. Also, collaboration with Material Systems, Inc. (Drs. R. Gentilman & L. Bowen) where the APDC is manufactured. Extensive collaboration is pursued with ATI-American Sportcopter Co. (Ms. Yao & Kevin McGonigle) to transition the developed technology.

Publications

1. M. Arafa, and A. Baz, "Dynamics of Active Piezoelectric Damping Composites", *J. of Composites Eng.: Part B*, Vol. 31, pp. 255-264, 2000.
2. M. Arafa, and A. Baz, "Energy Dissipation Characteristics of Active Piezoelectric Damping Composites", *J. of Composites Sci. & Tech.*, Vol. 66, 2000

PERFORMANCE OF DUAL FUNCTION APDC

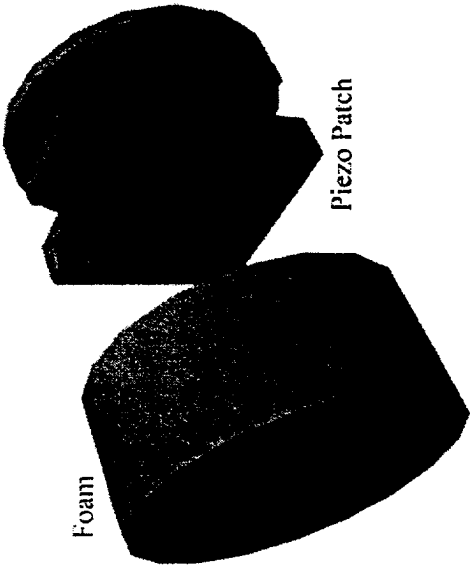

Foam

Piezo Patch

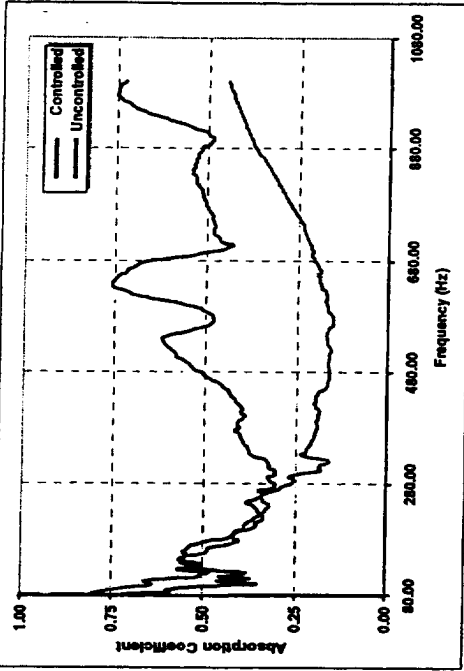
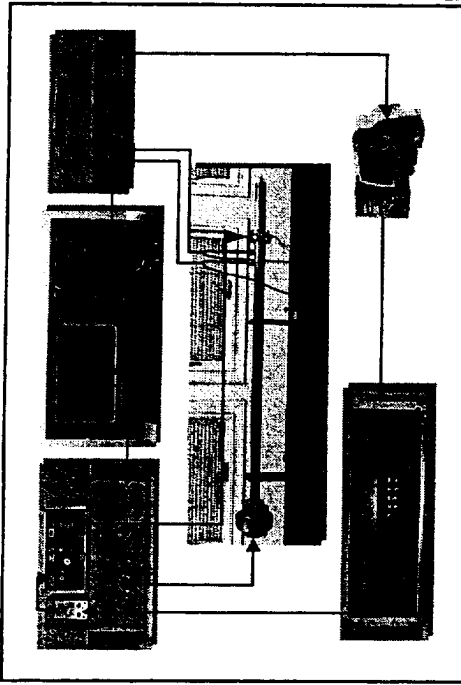

Dual-Function APDC

Experimental Set-Up

Performance

VIBRATION & NOISE CONTROL OF HELICOPTER

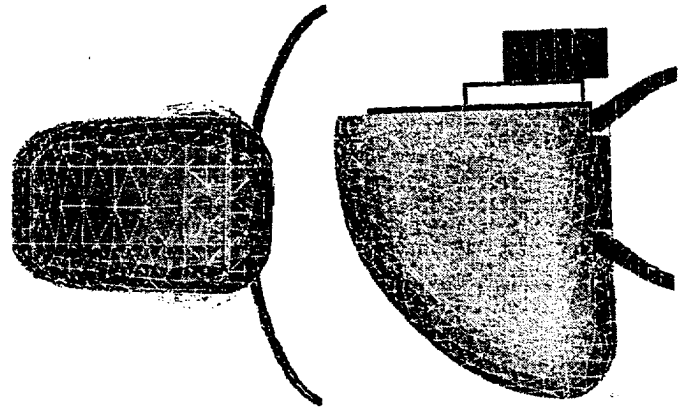

PCLD Configuration

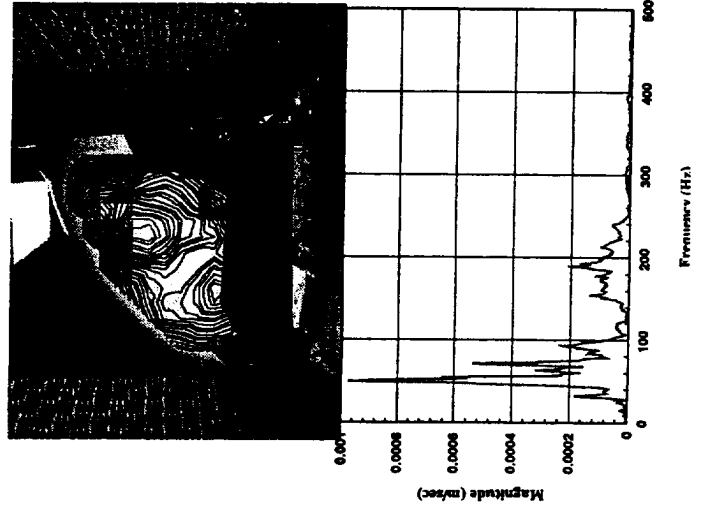

Untreated

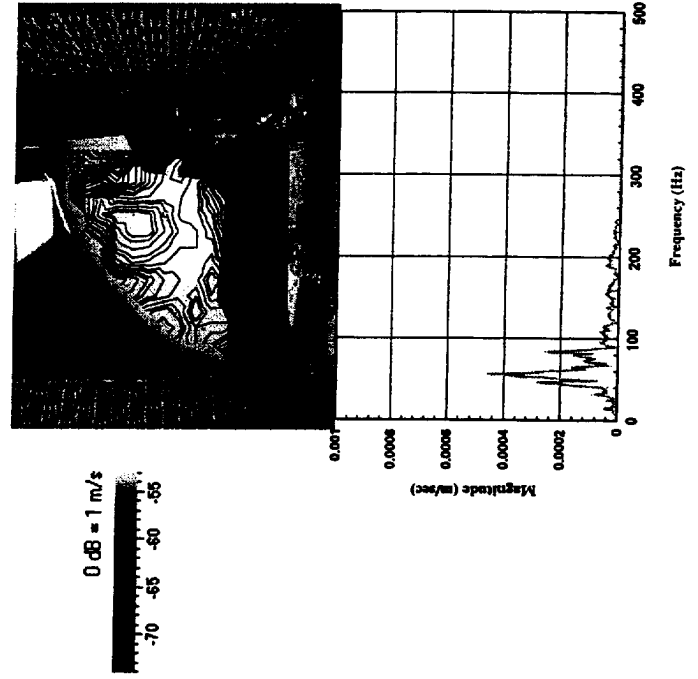

Cabin/PCLD

Task 3.1: Tip Actuated with Piezos and Bending-Torsion Couplings

Andreas P.F. Bernhard

Inderjit Chopra

Alfred Gessow Rotorcraft Center
Department of Aerospace Engineering
University of Maryland

RESEARCH OBJECTIVE

The objective is to develop and test a 1.83 m (6 ft) diameter 1/8th rotor model with active blade tips, activated via a piezo-induced bending-torsion coupled beam.

MOTIVATION

One of the major current rotorcraft challenges is active rotor control for vibration reduction. Smart structures are ideally suited to meet the requirements for compact, high band-width on-blade active devices, such as trailing edge flaps, controllable twist and all-moving blade tips.

RESULTS AND ACCOMPLISHMENTS

The smart active blade tip (SABT) rotor is a rotor incorporating blade tips that are independently pitched with respect to the main blade. These blade tips are used as on-blade control surfaces for vibration reduction, and driven by a piezo-induced bending-torsion coupled actuator beam, located spanwise in the hollow mid-cell of the main rotor blade. The experimental testing was carried out on a small scale rotor on a bearingless Bell-412 hub.

At Mach scale rotor speeds, with 100Vrms actuation, the blade tip deflection at the first four rotor harmonics is between ± 1.2 and ± 2.0 deg, increasing to ± 4.1 deg at 5/rev with resonant amplification. Raising the actuation level with a 2:1 amplification bias (150Vrms effective), the smart active blade tip (SABT) deflection at the first four harmonics is between ± 2.1 and ± 2.9 deg, increasing to over ± 5 deg at 5/rev. At the primary frequencies of interest (3, 4 and 5/rev) the measured SABT deflection is close to or exceeds the specified vibration reduction target of ± 3 deg.

Closed loop tests were performed with an adaptive neural network control algorithm and actuation of one blade. The controller was tasked to minimize either the oscillatory root flap bending or the fixed frame thrust. The controller reduced 1/rev vibration signals by over 85% in both cases. To further explore the capability of the controller in the hover tests, the controller was tasked to generate physical multi-frequency vibratory rotor loads, by minimizing an artificially injected vibration spectrum. The controller successfully generated 80 to 90% of the simultaneous 3, 4 and 5/rev control targets for root flap bending moment. With rotor thrust as selected control parameter, the controller successfully generated the simultaneous 3, 4 and 5/rev control targets. With 3 and 5/rev excitation, over 90% of the target thrust was reached, and at 4/rev 67% value was attained.

FUTURE WORK

1. Re-design of shaft assembly / bearing-block
2. Integration into comprehensive aeroelastic rotor code
3. Forward flight performance analysis
4. Wind-tunnel test
5. Full scale design study
6. Overall Feasibility Assessment

PUBLICATIONS AND PRESENTATIONS

1. A.P.F. Bernhard and I. Chopra, "Mach Scale Design of a Helicopter Rotor with Active Blade Tips," presented at *the Fourth ARO Workshop on Smart Structures*, August 16-18, 1999, University park, Pennsylvania.

2. A.P.F. Bernhard and I. Chopra, "Hover test of a Mach-scale rotor-model with active blade tips," *Proceedings of the 56th American Helicopter Society Forum*, Virginia Beach, VA, May 2000.
3. A.P.F. Bernhard, "Smart Helicopter Rotor with Active Blade Tips", Ph.D. Dissertation, Department of Aerospace Engineering, University of Maryland, May 2000.

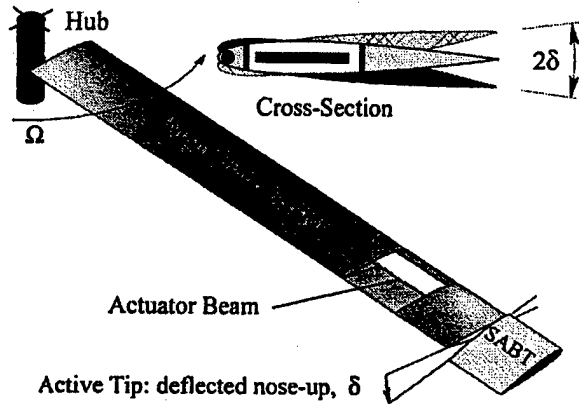

Fig. 1 Blade tip actuated with bending-torsion actuator

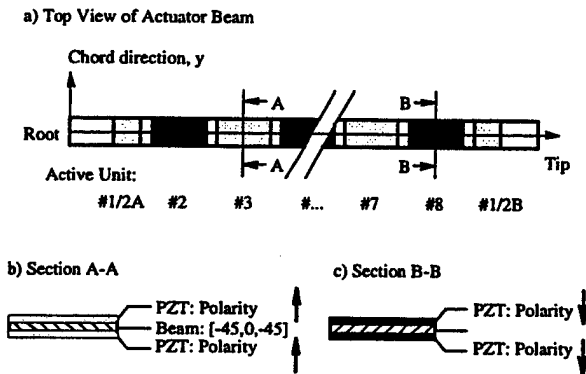

Fig. 2 Composite Bending-Torsion Beam

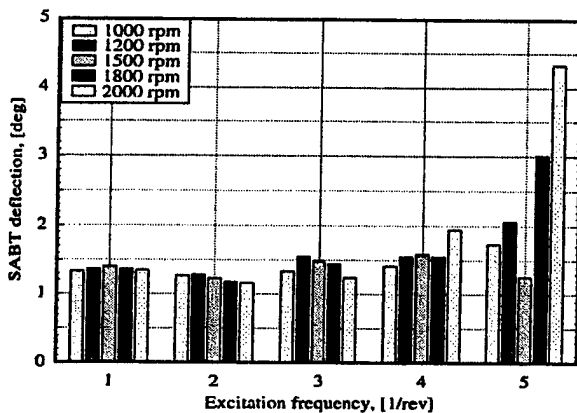

Fig. 3 Active blade tip rotor test in hover: Oscillatory tip amplitude with RPM sweep at 100 V_{rms} and 2 deg collective

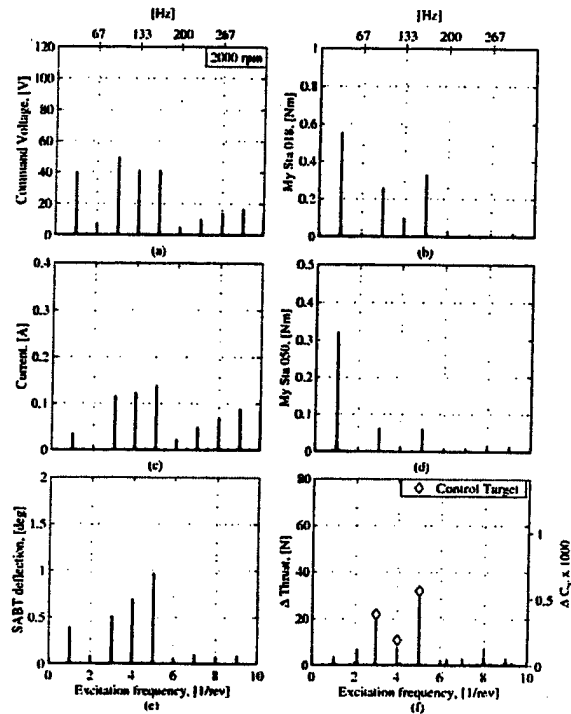

Figure 4 Closed loop test, control parameter thrust: simultaneous control targets 22, 11 and 32 N at 3, 4 and 5/rev; hover, 2000 rpm, 2 deg collective

Task 3.2: Active Rotor Blade with Piezoelectric Bender Actuated Trailing Edge Flaps

Nikhil A. Koratkar and Inderjit Chopra

Alfred Gessow Rotorcraft Center
Department of Aerospace Engineering
University of Maryland, College Park, MD 20742

Research Objective

Development of an intelligent rotor with piezoelectric-bender actuated trailing-edge flaps for active vibration control of rotorcraft.

Motivation

One of the major current rotorcraft challenges is vibration and noise reduction. The application of smart structures to rotorcraft for this purpose has become increasingly attractive with the development of compact, light-weight and high bandwidth solid state induced strain actuators. The advent of smart structures and materials opens up a hitherto unavailable domain for vibration control, aeromechanical stability augmentation, handling qualities enhancement, stall alleviation and acoustic suppression.

Concept

It is proposed to use trailing-edge flaps for individual blade control. The flap motion will generate new unsteady aerodynamic airloads, that correctly phased, will reduce fixed frame vibration by directly altering the airloads in the rotating frame. For the present research the trailing-edge flap is actuated using a solid state piezoelectric bender (See figure 1). This eliminates the need for a heavy and complex hydraulic slip ring unit and results in a light-weight, compact and efficient actuation mechanism.

Accomplishments

- Analytic model development

First, an analytic model was developed for the coupled actuator-flap rotor dynamic response in hover [1,2]. In parallel to the development of the analytic model a 2-bladed froude-scaled model (1/7 scale) with piezo-bender actuated trailing-edge flaps was designed and tested in hover. The analytic model showed good correlation with measured hover test data [2]. This indicated that the analytic model can be used as a tool for active rotor design studies and performance prediction in hover.

- Design of Mach-scaled model

Next, the analytic model was used to design a proof-of-concept 4-bladed Mach-scaled model (1/7-scale) with piezo-bender actuation. The design converged to a 8% span, 20% chord flap located at 75% span-wise location with associated deflection requirements of ± 4 deg. The analytic model predicts that an 8-layered tapered piezo-bender excited at 90 Vrms (3:1 bias) can achieve the target flap deflection of ± 4 deg. The analytic model also

indicated that the open loop flap actuator-flap control authority is highly frequency dependent. The flap effectiveness shows a dramatic increase close to the blade structural flap and torsion frequencies. In order to exploit this strong modal coupling the blade mass and stiffness distributions were tailored so that the blade 1st torsion and 3rd flat-wise bending frequencies were placed close to the rotor 3/rev and 5/rev harmonics. This maximizes the control authority in the range 3 to 5/rev which holds the key to vibration reduction . Table 1 summarizes the Mach-scale design parameters.

- Open Loop frequency sweep tests (Hover)

The model blades were tested on the University of Maryland hover test stand. The tests were conducted using a Bell-412 Mach-scaled Bearingless rotor hub. The tests consisted of open-loop frequency sweeps at the Mach-scaled operating speed of 1800 RPM. Only one flap was activated for these tests. Figure 2 shows the response for flap deflections, while figure 3 illustrates the normal force response. Figure 3 shows that the flap control authority shows a dramatic increase close to the rotor 1st flap-bending (31.4 Hz), 1st torsion (92 Hz) and 3rd flap-bending (155 Hz) frequencies.

- Closed loop tests in wind tunnel

The rotor model was tested in the Glen L. Martin wind tunnel (figure 4). For these tests, all four blades were activated and the neural network controller [3] was used to command the actuator-flap system to suppress both rotating frame (flatwise bending moment) and fixed frame (thrust, pitching moment, rolling moments) vibratory hub loads. The tests were classified into three categories: single load suppression, multiple load suppression and transient cases. Figure 5 shows an example of single load (flat-wise bending moment) control. The neuro-controller is able to reduce the baseline vibratory hub load by 90%. Figure 6 demonstrates multiple load suppression (thrust, pitching and rolling moments). The neuro-controller is able to simultaneously suppress the thrust, pitching moment and rolling moment by over 90%. Figure 7 and 8 describe transient tests, wherein the controller was allowed to converge at a particular flight condition and then the rotor speed and wind speed were perturbed in order to simulate transient maneuvers. Figure 7 and 8 show that throughout the duration of the perturbation, the load levels with controller on are lower than the baseline values.

Summary and conclusions

These tests demonstrate the technical feasibility of using piezoelectric bender driven trailing-edge flaps for helicopter vibration control. Open loop frequency sweep characterization of the system indicates large control effectiveness close to the rotor blade structural flap and torsion frequencies. The 4-bladed Mach-scaled rotor model provides an excellent test bed for control system design and refinement. The neural network based controller was found to successfully minimize multiple loads in the fixed frame (thrust, pitching moment, rolling moments) as well as rotating frame loads (blade root flat-wise bending moments). The controller was also found to perform well during transient conditions.

REFERENCES

1. Koratkar N. A., and Chopra I., "Analysis and Testing of a Froude-scaled helicopter rotor in hover with piezo-bender actuated trailing-edge flaps", *Journal of Intelligent Material Systems and Structures*, Vol. 8, No.7, July 1997, pp. 555-570
2. Koratkar N. A., and Chopra I., "Analysis and Testing of a Mach-scaled helicopter rotor in hover with piezo-bender actuated trailing-edge flaps", *AIAA Journal*, Vol. 38, No.7, July 2000, pp. 1113-1124.
3. Spencer M., and Chopra I., "Neurocontrol of simulated full scale rotor vibrations using trailing-edge flaps", *Proc. of the 40th AIAA/ASME/ASCE/AHS/ASC Structures, Structural Dynamics and Materials Conference*, St. Louis, MO, April 11-15, 1999.

<p>Rotor Blade Diameter: 60 in. (5 ft) Chord: 3 in. Number of blades: 4 Blade weight: 280 gm Actuator weight: 43 gm Flap Dimensions Span: 8% radius (2.4 in.) Chord: 20% chord (0.6 in.) Location: 75% radius</p>	<p>Operating Condition RPM: 1800 Tip Mach (Hover): 0.45 CF Load: 3400 g Lock Number: 3.4</p>
--	---

Table 1: Mach-scaled model design parameters

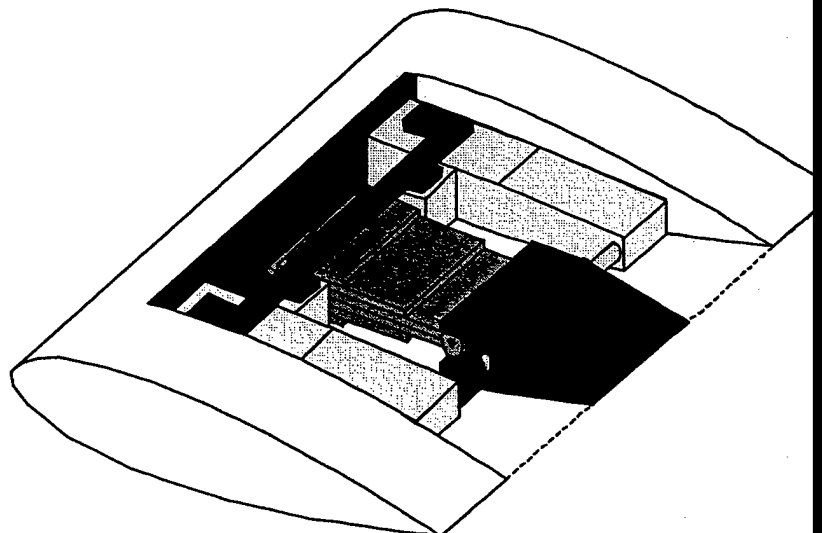
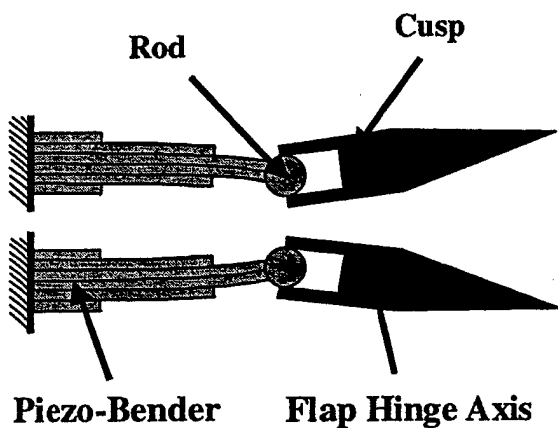

Figure 1 : Piezoelectric bender actuation

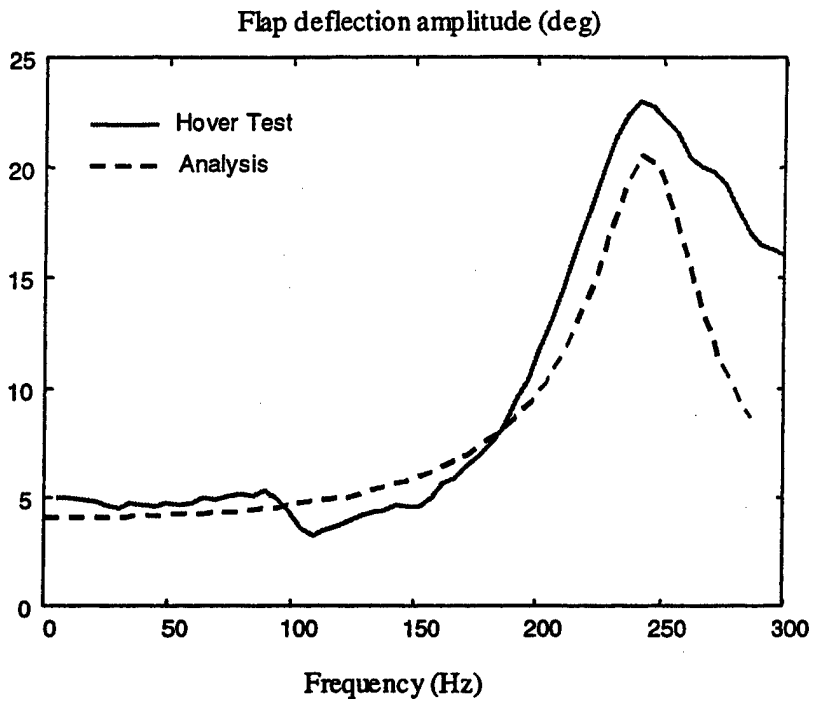

Figure 2 : Hover Test (1800 RPM, 2 deg collective, actuator excited at 90 Vrms with 3:1 AC bias)

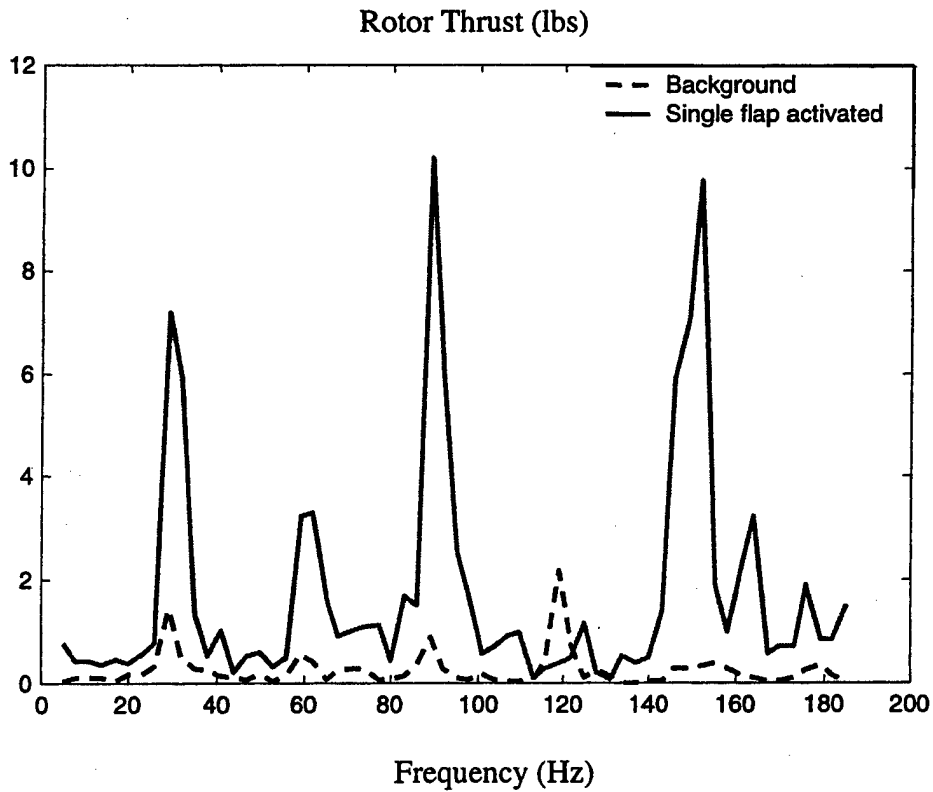

Figure 3 : Hover Test (1800 RPM, 2 deg collective, actuator excited at 90 Vrms with 3:1 AC bias)

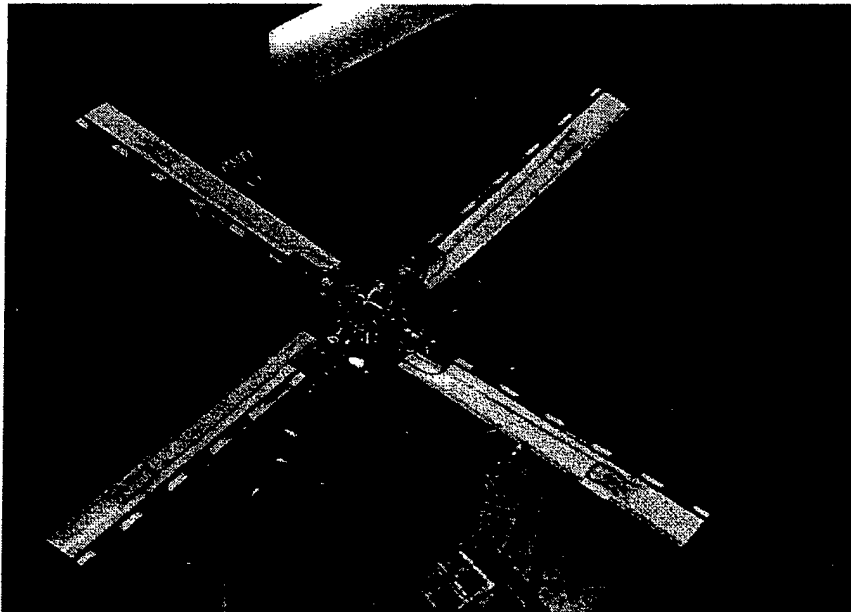

Figure 4: Glenn L. Martin wind tunnel (11 by 7.5 ft test section)

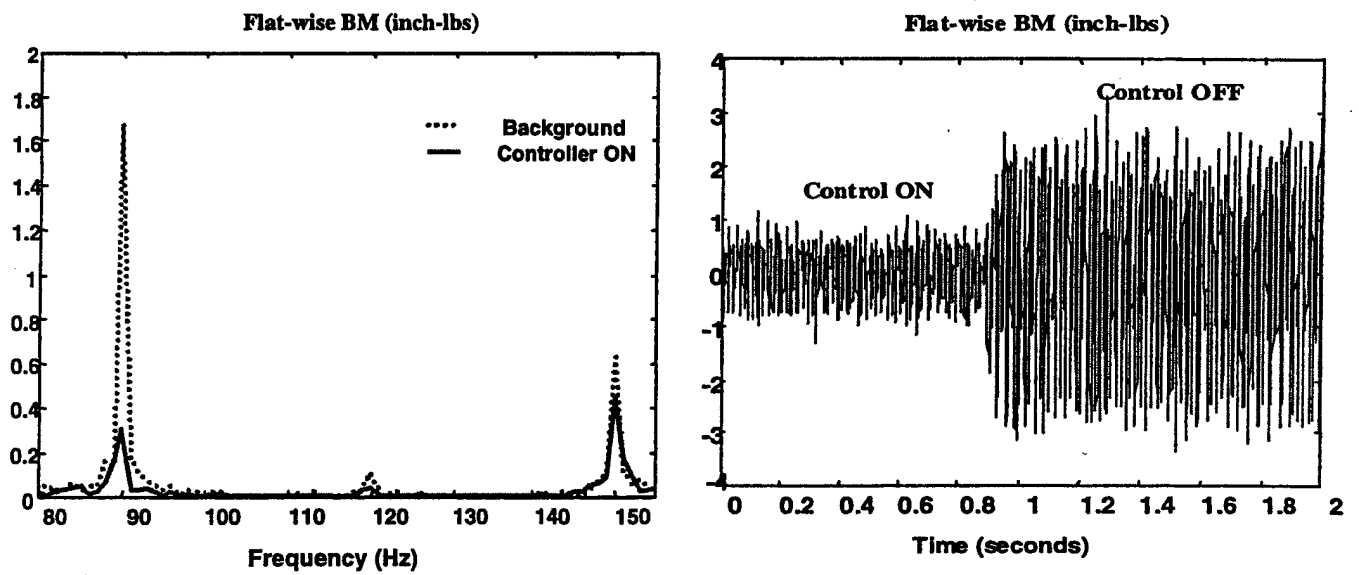

Figure 5: Single load case (blade root flat-wise bending moment control, 1800 RPM, 0.3 advance ratio, 6 deg collective pitch)

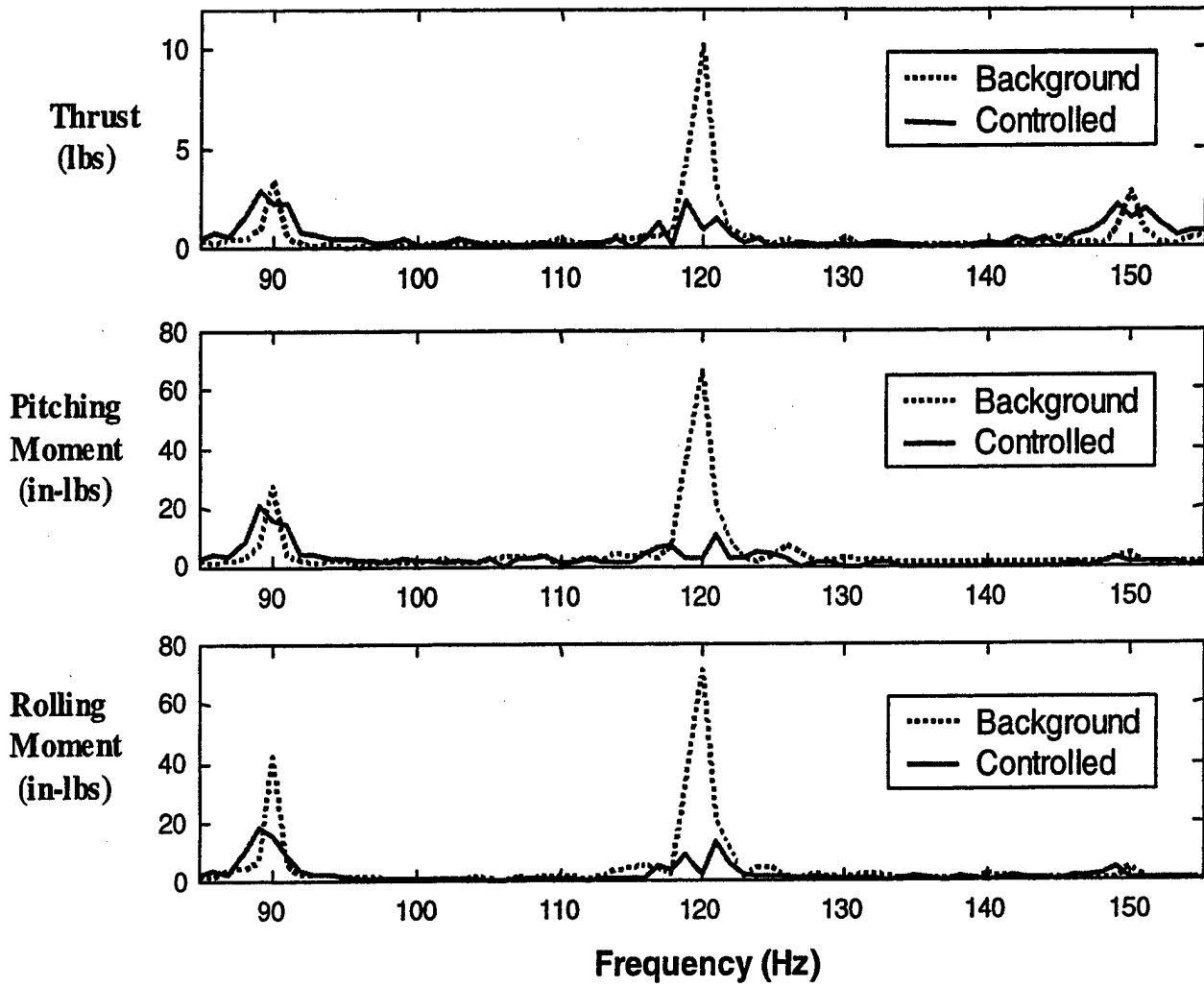

Figure 6: Multiple load control (thrust, pitching moment, rolling moments, 1800 RPM, 0.2 advance ratio, 2 deg collective pitch)

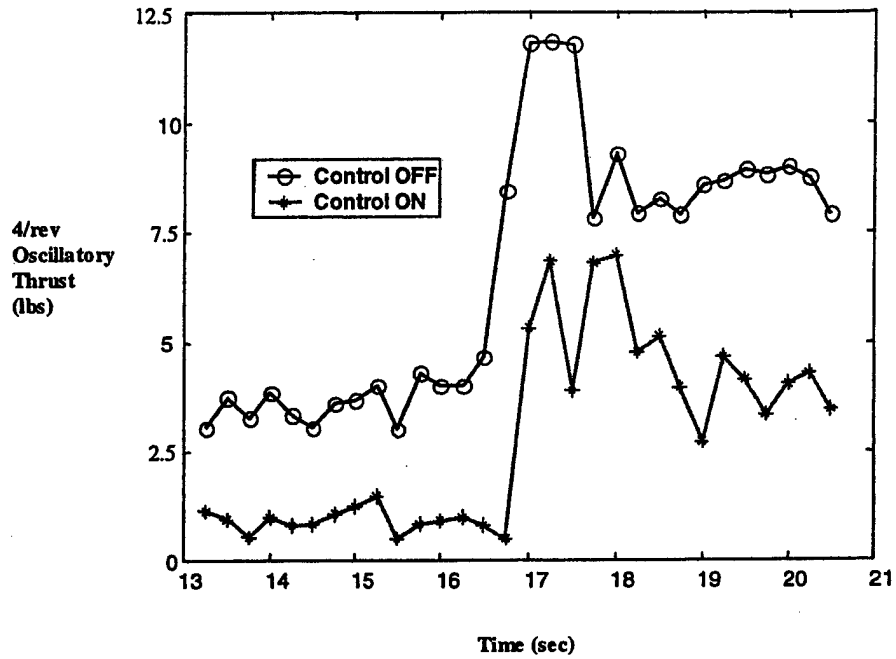

Figure 7: Transient test - RPM varied from 1500 to 1600 (16.5 to 17.8 sec)

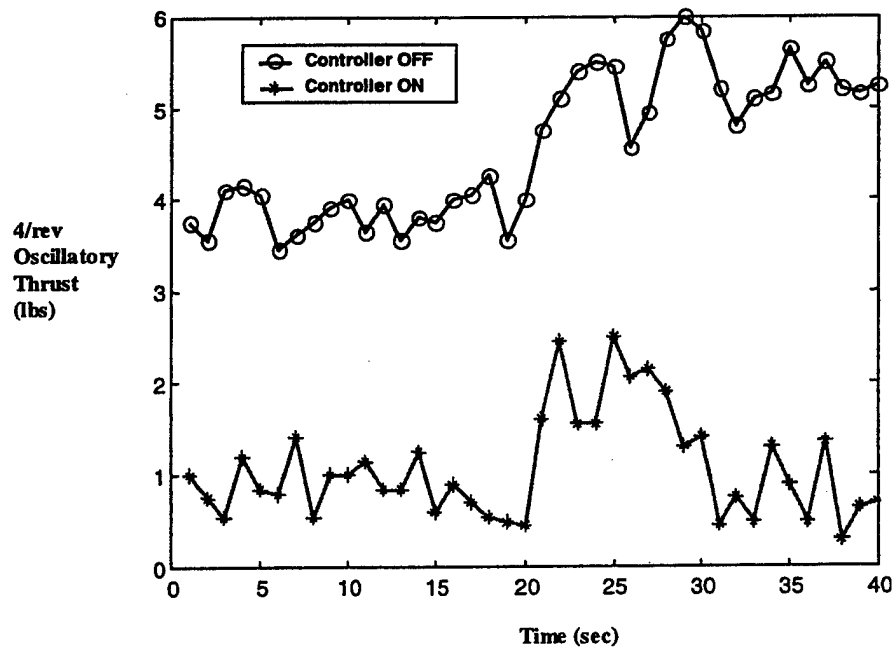

Figure 8: Transient test - wind speed varied from 27 to 54 mph (20 to 30 sec)

Task 3.3: Trailing-Edge Flap Actuated with Piezoelectric Stacks

Taeoh Lee and Inderjit Chopra

Alfred Gessow Rotorcraft Center
Department of Aerospace Engineering
University of Maryland

Research Objective

To systematically investigate the feasibility of the trailing-edge flap operating in rotating environment using piezoelectric stacks in conjunction with refined stroke amplification mechanism.

Motivation

Piezoceramics are potential actuators for a wide range of applications to actively control vibration, to improve the performance and to augment aeromechanical and flight stability. In rotorcraft application, there are major barriers such as small stroke of the actuator and high stress due to centrifugal forces. To overcome the low force limitation of piezoceramic sheet based actuator, the actuators using piezoelectric stacks are investigated.

Approach and Accomplishments

The first step was to down-select the piezostack with good mechanical and actuation characteristics, and to design a mechanical amplification concept capable of obtaining moderate force/stroke from high force and low stroke of piezostack. A dual-stage mechanical amplification concept (L-L) was developed, which extends the capability of conventional lever-fulcrum amplification system. The prototype actuators to activate the blade trailing-edge flap were designed and fabricated with down-selected piezostacks. The prototype actuators are tested on bench-top, in vacuum chamber and in wind tunnel to demonstrate the feasibility of L-L amplification mechanism in rotating environment. These tests were carried out at different actuation voltages, frequencies, and external loads. Three different preload cases were examined on bench-top test: zero preload, dead-weight preload, and spring preload. The vacuum spin testing was performed for the rotational speed of 1000 RPM, which corresponds to approximately 700g of full-scale centrifugal loading. No major degradation in peak-to-peak output displacement was observed due to the frictional or other structural losses. The Open-jet wind tunnel test was conducted using a blade section of 12-inch span and 12-inch chord, in which the trailing edge flap was actuated through a modified push rod mechanism. The blade section was tested for freestream speeds up to 120 ft/sec and angles of attack up to 12 degrees. This demonstrated that the L-L actuator could be used for operation in full-scale rotating environment.

Future Plans

1. Fabrication of bidirectional L-L actuator
2. Bench-top test
3. Wind-tunnel test

External Collaboration

Studies related to the evaluation of piezostack characteristics and development of mechanical stroke amplifier were collaborated with Boeing-Mesa (Friedrich Straub).

Publications and Presentations

1. Lee, T., and Chopra, I., "Design and Validation of a Multi-Stage Stroke Amplifier for Piezostack-Based Trailing-Edge Flap Actuator," presented at *the Fourth ARO Workshop on Smart Structures*, August 16-18, 1999, University park, Pennsylvania.
2. Lee, T., "High Displacement Piezoelectric Trailing-Edge Flap Mechanism for Helicopter Rotors", Ph.D. Dissertation, Department of Aerospace Engineering, University of Maryland, December 1999.
3. Lee, T., and Chopra, I., "Development of a Smart Trailing-Edge Flap Actuator with Multi-Stage Stroke Amplifier for a Rotor Blade," *Proceedings of SPIE Conference on Smart Structures and Materials*, March 2000, Newport Beach, CA.
4. Lee, T., and Chopra, I., "Wind Tunnel and Vacuum Chamber Testing of a Piezoelectric Double-Lever Actuator for Trailing-Edge Flap Control", accepted for presentation, *American Helicopter Society Active Controls Technology Conference*, October 4-5, 2000.

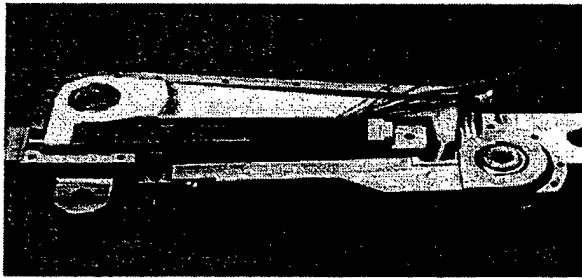

(a)

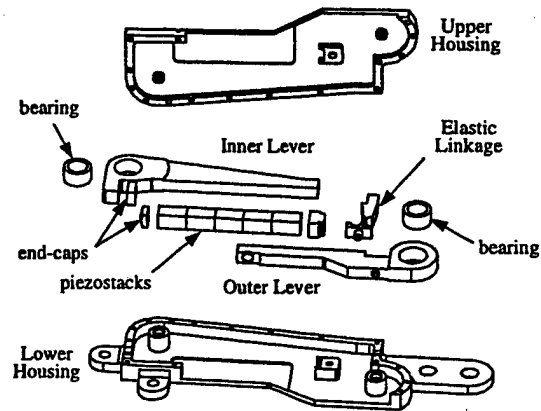

(b)

Figure 1 Second prototype L-L actuator: (a) assembled unit and (b) detailed schematic

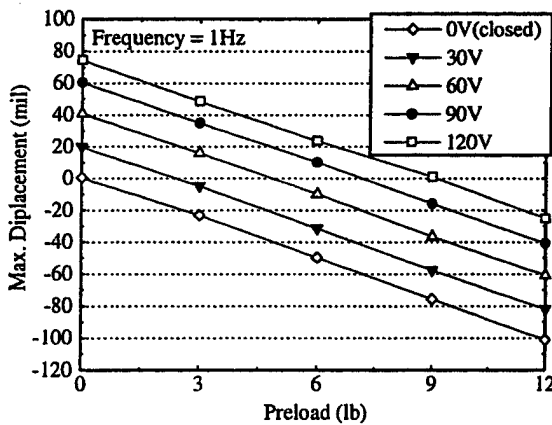

(a)

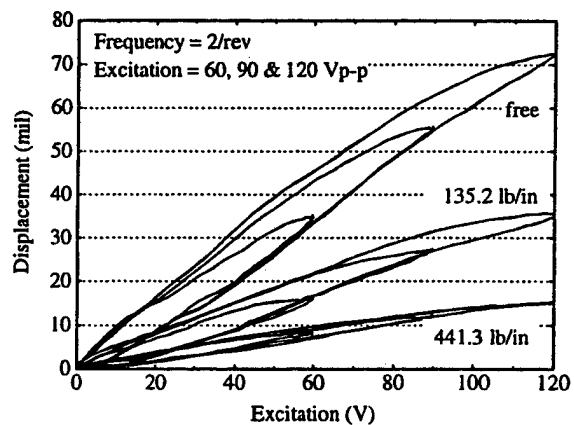

(b)

Figure 2 Behaviors of second prototype L-L actuator: (a) displacement vs. preload and (b) hysteretic behaviors with spring loads at 13.1 Hz (2/rev)



(a)

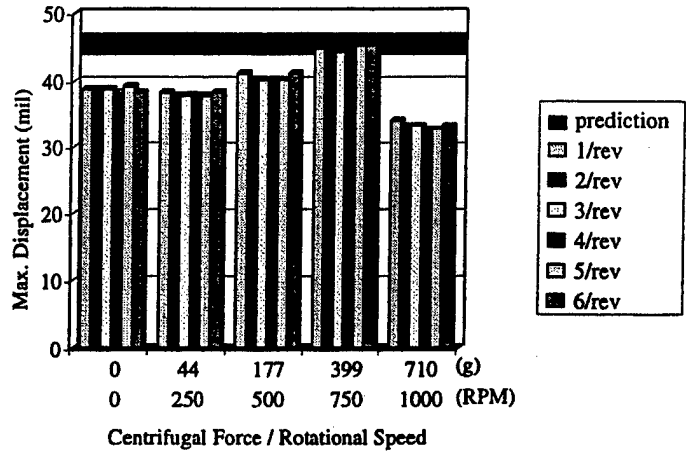

(b)

Figure 3 Vacuum Spin Test of second prototype L-L actuator: (a) actuator set-up and (b) actuator displacement vs. CF loading at 90 V_{p-p} excitation (Free displacement: 56.4 mils)

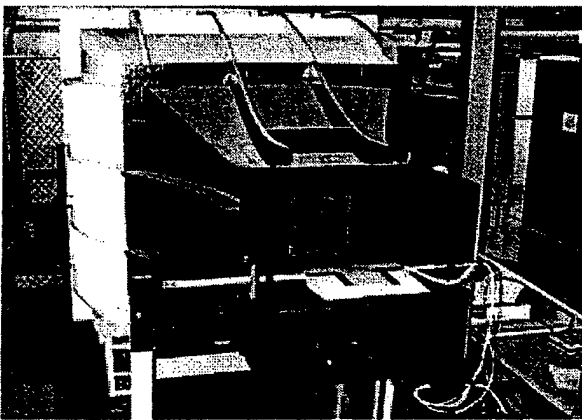

(a)

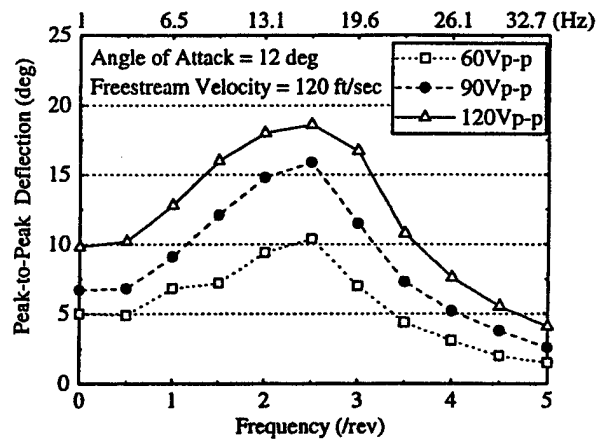

(b)

Figure 4 Open-jet wind tunnel test: (a) test set-up and (b) peak-to-peak flap deflection vs. frequency for the angles of attack of 12° (freestream velocity 120 ft/sec)

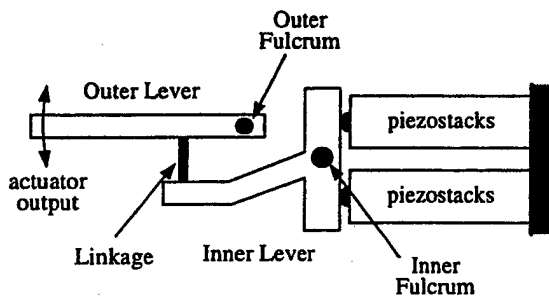

(a)

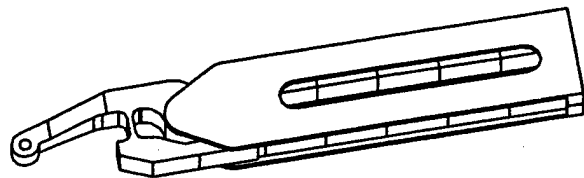

(b)

Figure 5 Bidirectional L-L actuator: (a) amplification concept and (b) schematic of prototype actuator

Task 3.3

IN-FLIGHT TRACKING OF HELICOPTER ROTOR BLADES USING SHAPE MEMORY ALLOY ACTUATORS

Jeanette J. Epps, Harsha Prahlad and Inderjit Chopra
Alfred Gessow Rotorcraft Center
Department of Aerospace Engineering
University of Maryland, College Park, Maryland 20742

Research Objective

The objective of the present study is to experimentally characterize the uniaxial behavior of Shape Memory Alloy (SMA) wires and examine the feasibility of using a shape memory alloy wire actuator for tracking of a helicopter rotor. The use of an SMA torque tube for twist actuation of a tilt-rotor blade is also suggested.

Motivation

Blade dissimilarities, in the form of structural, inertial or aerodynamic, among helicopter blades can cause a tremendous increase in vibratory forces (primarily at 1/rev frequency) that can introduce more vibrations, lower fatigue life of components and yield less acceptable handling qualities. Currently, to overcome this problem, in-shop tracking of blades is done periodically resulting in a significant increase in operating cost and helicopter downtime. Tracking is performed manually by adjusting trailing-edge tabs of helicopter blades in an iterative manner. Also to minimize blade dissimilarity, tight manufacturing tolerances are imposed on rotor blades leading to high procurement cost. Although blade tracking and tight tolerances minimizes vibrations, they are time consuming and expensive. In the present study, it is proposed to track helicopter rotor blades while in-flight, as opposed to manually in-shop, using a shape memory alloy actuator. Possessing the ability to track helicopter blades while in-flight has several advantages: (1) minimization of one per rev vibrations, (2) relaxation in manufacturing tolerance of blades, (3) less downtime, (4) decrease in overall operating and procurement costs, and (5) an increase in fatigue life of structural components and instrumentation.

Tilt-rotors have different aerodynamic requirements in hover and forward flight. The optimum twist distribution of the rotor in hover is quite different from that in forward flight. The use of an active mechanism to alter the twist distribution of the rotor from hover to forward flight mode can result in a significant increase in performance (5-10%), directly resulting in payload benefits.

Approach

To utilize SMA's in the development of a tab actuator, a comprehensive study of the quasi-static behavior of the SMA's was undertaken. Experimental data was used to validate several constitutive models that predicted uniaxial behavior of SMAs, and these models showed acceptable correlation with experimental results for quasi-static loading. The influence of strain rates on the behavior of SMAs was investigated.

The research in SMA culminated in the development of a tab actuator model to predict the behavior of the SMA-Sma actuator. The model uses Brinson's model for SMAs to predict the displacement of a trailing edge tab actuated via shape memory alloy wire actuators (see figures). A tab actuator employing two sets of SMA wires attached to the hinge of a trailing edge tab was developed. Also, to maintain a specified tab angle, a tab lock was introduced. Finally, a displacement feedback controller was assembled. The tracking system was tested on the bench-top and in the open-jet wind tunnel to provide data on actuator performance

The research is also currently investigating the use of an SMA torque tube attached to a tilt-rotor blade in order to alter twist distribution of the blade from hover to forward flight modes. Initial studies using a baseline XV-15 blade have indicated the feasibility of this concept.

Accomplishments

1. SMA testing: stress-strain-temperature behavior, constrained recovery behavior (partial or no recovery of plastic deformation), and free recovery behavior (all of plastic deformation recovered) investigated.
2. Experimental validation of several constitutive models for SMA's: theoretical stress-strain temperature curves validated with experimental data, and constrained recovery stress-temperature behavior (no recovery of plastic deformation) predicted.
3. Experimental investigation into the effect of dynamic loading on the SMA actuators carried out.
4. A SMA-SMA actuator model was developed and the model was validated with experimental data.
5. Construction of a tab-actuator employing antagonistic sets of SMA wires embedded in a NACA 0012 wing section. A tab lock and a displacement feedback controller were also built. The entire system was tested on the open jet wind-tunnel and provided excellent performance, indicating the feasibility of the actuator for automatic in-flight tracking of helicopter rotors.

Future Plans

Future work on the wing section with the tab actuator will involve improvement of the design with refinements in the locking mechanism, controller design and analytical predictions. The use of an SMA torque tube for this application is also being studied, and the experimental characterization is in progress. The design of a composite blade representative of a tilt-rotor blade employing SMA torque tube for twist actuation is also being studied. Design and testing of the actuation mechanism to alter twist distribution in the tilt-rotor blade will be carried out.

Selected Publications

1. Prahlad, H, and Chopra, I. "Experimental Investigation of Shape Memory Alloys under uniaxial loading", Accepted for Publication, *Journal of Intelligent Material Systems and Structures*, Special edition (ARO Workshop)
2. Epps, J. J., and Chopra, I., "Comparative Evaluation of Shape Memory Alloy Constitutive Models with Test Data," Proceedings of the 38th Structures, Structural Dynamics and Materials Conference and Adaptive Structures Forum, April 7-10, 1997, Kissimmee, Florida.
3. Epps, J. J., and Chopra, I., "In-flight Tracking of Helicopter Rotor Blades Using Shape Memory Alloy Actuators," Proceedings of the annual Forum of the American Helicopter Society, May 2000, Virginia Beach, VA

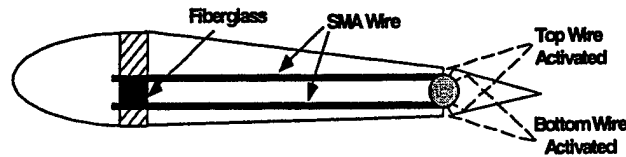

Figure 1: Tab actuation mechanism

Figure 1 shows a schematic diagram of an airfoil section with a tab actuated using SMA wires. To deflect the tab downward, the bottom wire is heated while the top wire remains at ambient conditions. To bring the tab back to its neutral position, the top wire is heated next. Again upon heat activation, the wire will recover a part of its plastic deformation (or pre-strain) and a recovery force will develop, which will move the tab up. If such a tab system is used for in-flight tracking of a helicopter rotor, it is important to lock the tab at the desired position.

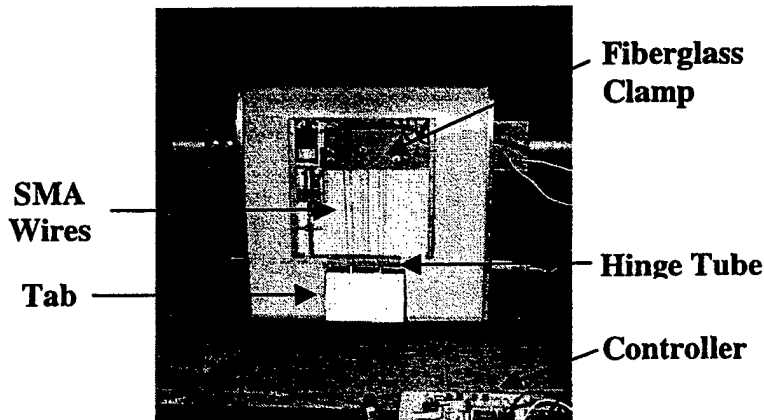

Figure 2: Tracking tab assembly

Figure 2 shows the actual tab actuator embedded within NACA 0012 wing section. The actuator consists of a wire clamp, a hinge tube, and a tab lock. To electrically insulate the wires, the clamp and the hinge tube were fabricated out of fiberglass. The wire clamp has a top plate, center plate and a bottom plate, and it's all held together with fourteen bolts. These plates allow two sets of wires to be clamped to the spar while being electrically insulated from each other. Therefore, the upper set of wires can be activated while the lower set is at ambient conditions. A NACA 0012 wing section with a 12-inch chord and span and a maximum thickness of 1.44 inches was fabricated. Subsequently, the tab was cut from the center portion of the trailing edge of the wing section. The dimensions of the tab are 2.4-inch chord (20% of the wing section's chord) and a 4-inch span.

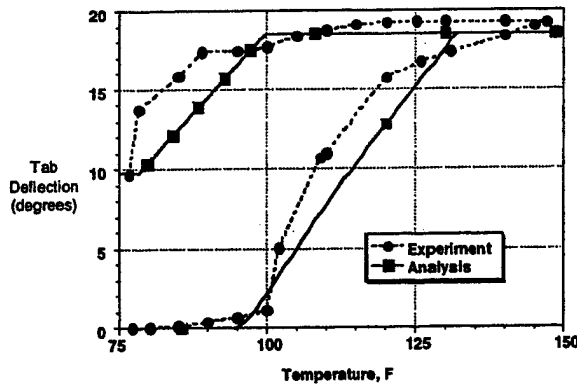

Figure 3: Benchtop testing

Figure 3 displays the measured and calculated tab angle versus temperature for wires with 3.16% initial pre-strain. A maximum tab deflection of approximately 19° was obtained.

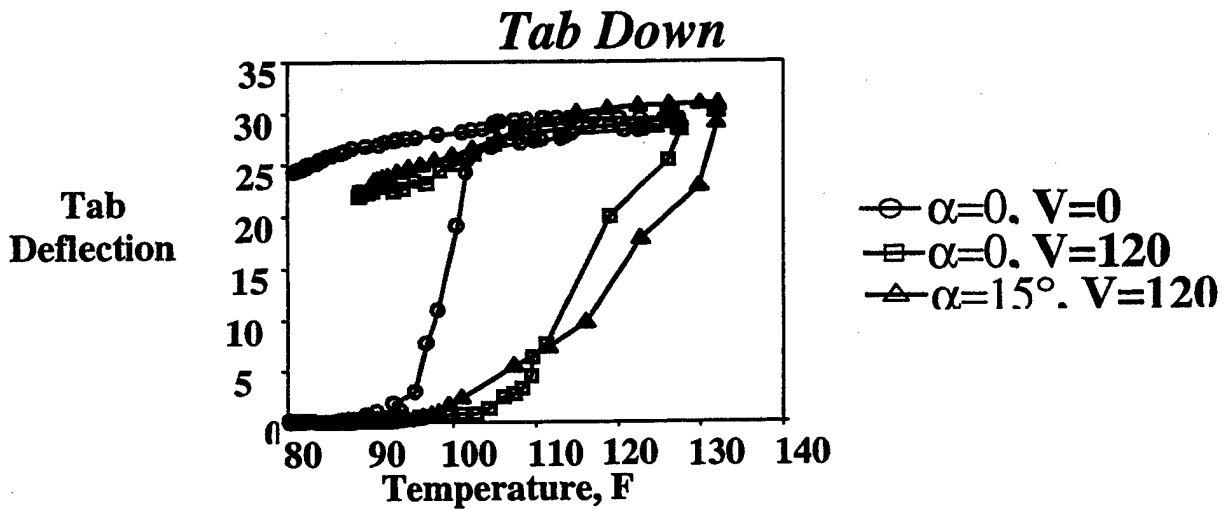

Figure 4: Open-jet wind Tunnel Performance

Figure 4 displays the measured tab angle versus temperature for different free-stream velocities and angles of attack in the open-jet wind tunnel. A maximum tab down deflection of approximately 30° was obtained with repeatable performance independent of the aerodynamic load.

Task 3.3.5 : Development of Neural Network Based Adaptive Controller for Rotor Vibration Suppression

Michael Spencer, Beatrice Roget, Robert Sanner and Inderjit Chopra

Alfred Gessow Rotorcraft Center
Department of Aerospace Engineering
University of Maryland, College Park, MD 20742

Research Objective

Develop a robust individual blade control (IBC) methodology for vibration suppression using a trailing-edge flap.

Motivation

One of the major challenges in rotorcraft technology is vibration and noise reduction. The application of smart structures to rotorcraft for this purpose has become increasingly attractive with the development of compact, lightweight and large bandwidth solid state induced strain actuators. The advent of smart structures and materials opens up a hitherto unavailable domain for vibration control, aeromechanical stability augmentation, handling qualities enhancement, stall alleviation and acoustic suppression.

Concept

It is proposed to use trailing-edge flaps for individual blade control. The flap motion will generate new unsteady aerodynamic airloads, that if correctly phased, will reduce fixed frame vibration by directly altering the airloads in the rotating frame. Recent analysis of vibration control for rotor blades with trailing edge flaps has been based on a higher harmonic type algorithm. These methods use a linear sensitivity matrix that relates the higher harmonics of the flap input to the harmonics of the vibratory hub loads. Although tests have demonstrated the ability to reduce hub vibrations, the performance may be poor if significant nonlinearities exist or if the operating condition differs significantly from that at which the sensitivity matrix was determined.

The goal of this research is to develop a new IBC method, robust to uncertainties in the blade structure or the aerodynamic loading, and capable of countering the vibration caused by any time periodic disturbance. The control method proposed employs a neural network to learn to actuate the trailing edge flap so as to adaptively suppress the blade vibrations. In this application, no off-line training is performed. Instead, a neural network is used, in real time, to adaptively command the trailing edge flap deflections that reduce or eliminate blade vibrations.

Approach

The new neurocontrol algorithm is achieved by reformulating the problem in a discrete, time-periodic framework. The time period of interest is segmented into a set of points at which a neural network is to approximate the flap inputs that would cancel the vibratory forces at the point of interest (blade root). This ideal input is not known a priori, and thus must be estimated on-line by the neural network. By explicitly relating the neural network coefficients to the expected samples of the blade vibration, a Kalman filtering algorithm is used as the basis of a new adaptation algorithm for the ideal network weights. This new discrete time approach reliably enables the neural network to learn in real time the necessary trailing edge flap command profile to counter the vibrations arising from an arbitrary periodic disturbance.

Accomplishments

Experimental validation of the neural controller in wind tunnel tests has been accomplished. Vibration reduction of more than 90 % has been accomplished for single load control case, and more than 80 % for each load in a multiple load control case. The algorithm was able to adapt to changes in flight condition with a constant vibration reduction during transient tests.

Future Work

Refinement of neural controller for individual blade control of vibration during steady and transition flight regimes.

Publications

1. "Closed Loop Hover Test Results with a Neurocontroller on a piezoactuated Trailing Edge Flap Blade", Spencer, M.G., Sanner, R.M., and Chopra, I., Univ. of Maryland, College Park, SPIE proceedings vol.3985, March 2000
2. "Neurocontrol of Simulated Full Scale Rotor Vibrations Using Trailing Edge Flaps," Spencer, M.G., Sanner, R.M., and Chopra, I., *Proceedings of the 40th AIAA/ASME/ASCE/AHS/ASC Structures, Structural Dynamics, and Materials Conference and AIAA/ASME/AHS Adaptive Structures Forum*, St. Louis, MO, April 1999.
3. "Adaptive Neurocontrol of Rotorcraft Vibrations Using Trailing Edge Flaps," Spencer, M.G., Sanner, R.M., and Chopra, I., to appear in *Journal of Intelligent Material Systems and Structures*.
4. "Development of Neural Network Controller for Smart Structure Activated Rotor Blades," *Proceedings of the 39th AIAA/ASME/ASCE/AHS/ASC Structures, Structural Dynamics, and Materials Conference and AIAA/ASME/AHS Adaptive Structures Forum*, Long Beach, CA, pp. 3326-3336, April 1998.
5. "An Adaptive Neurocontroller for Vibration Suppression and Shape Control of a Flexible Beam," Spencer, M.G., Sanner, R.M., and Chopra, I., *Journal of Intelligent Material Systems and Structures*, Vol. 9 (3), pp. 160 - 170, Mar 1998.
6. "Adaptive Nonlinear Neural Network Controller for Rotorcraft Vibration," *Proceedings of the SPIE Symposium on Smart Structures and Materials*, San Diego, CA, March 1997

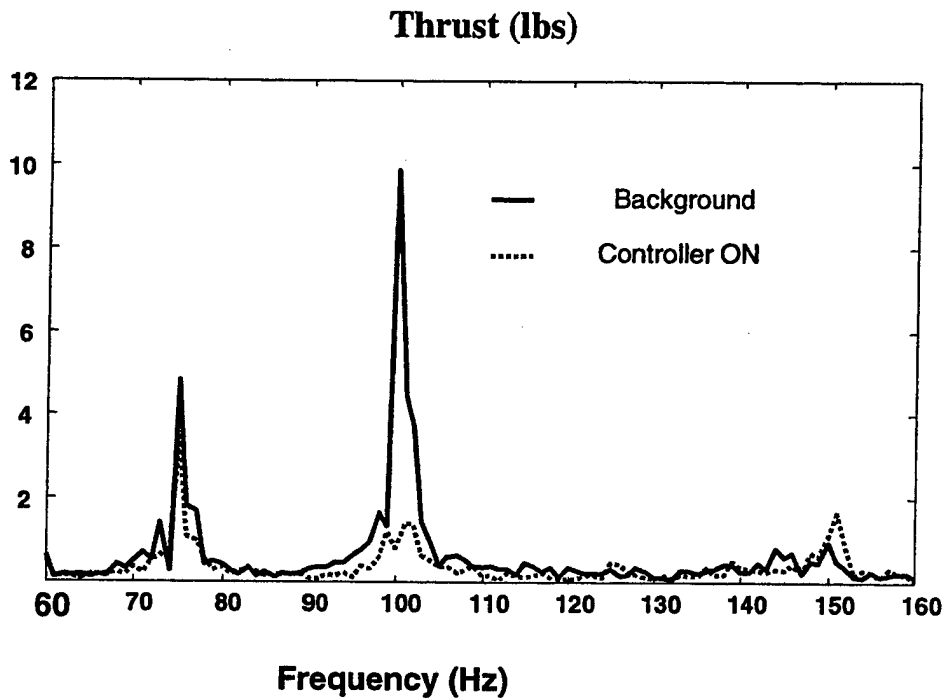

Fig.1: Thrust Control (1500 RPM, 0.3 Advance ratio, 2 deg collective)

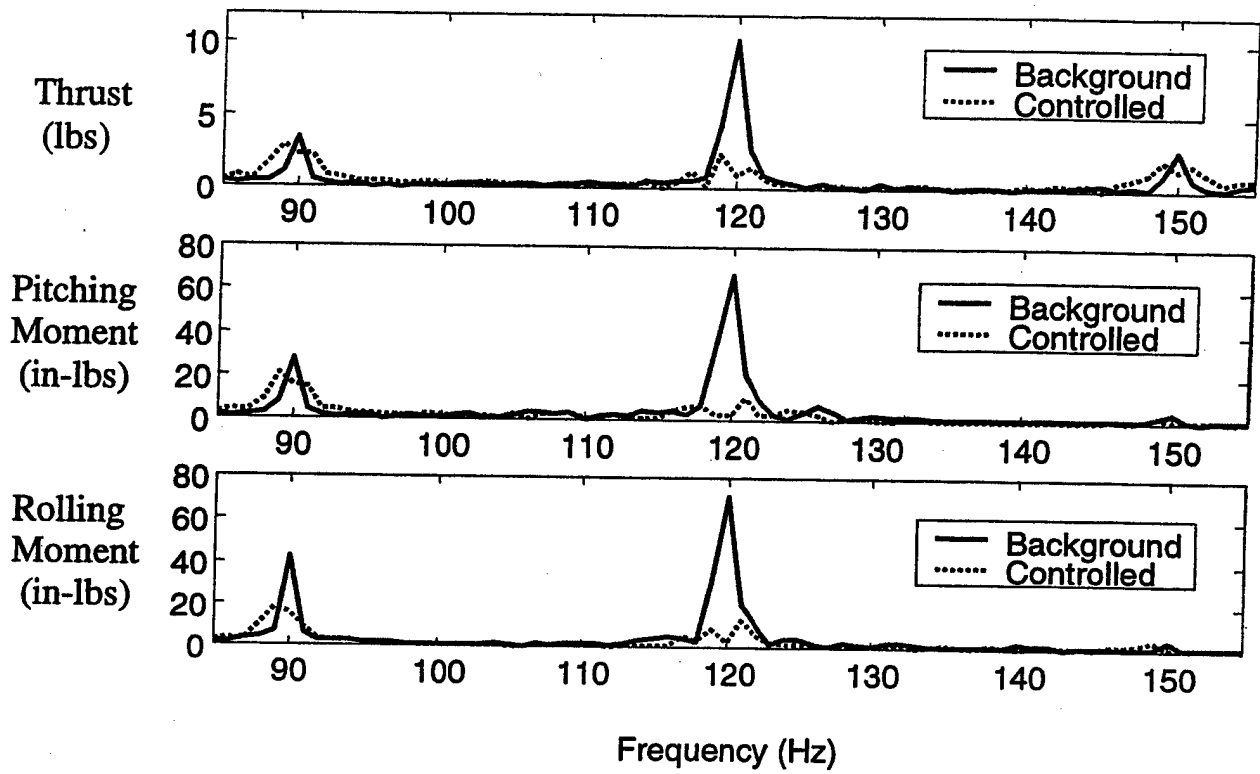

Fig.2: Multiple Load Suppression (Thrust, Pitching and Rolling Moments)

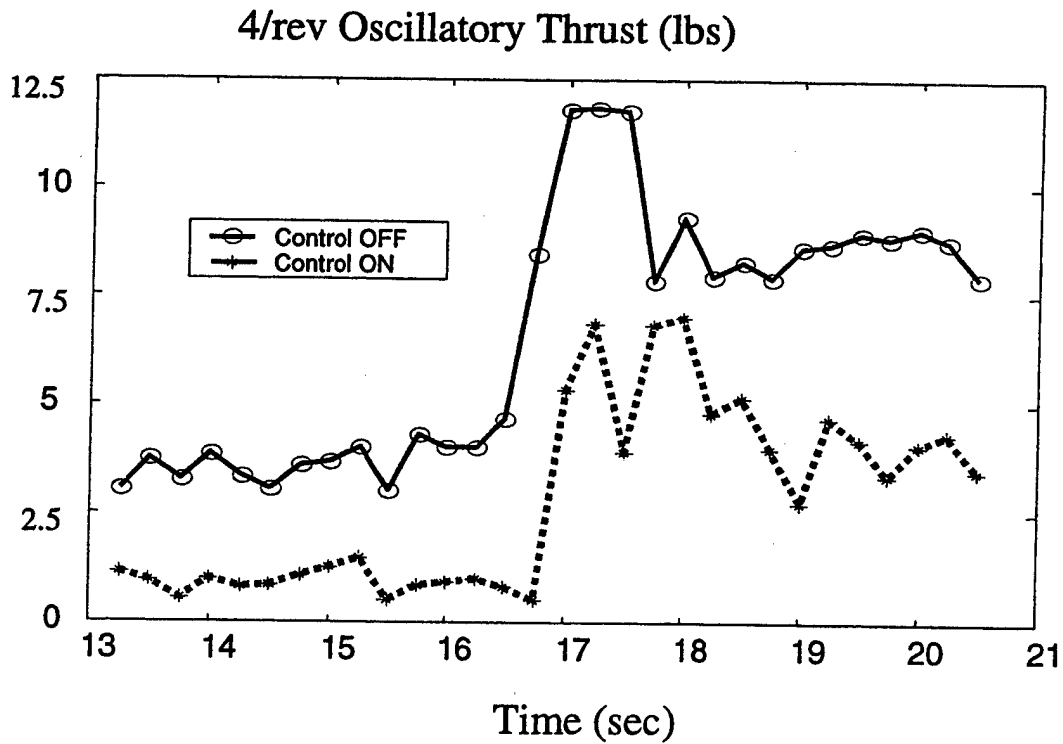

Fig.3: Rotor Speed Variation (1500 to 1600 RPM in 1 sec)

Task 4.1

Active Vibration Control of Rotorcraft Driveshaft-Airframe Dynamics

Introduction

Conventional helicopter tailrotor-driveshafts and associated drivetrain components have significant maintenance requirements, which are a result of vibration levels encountered during routine flight operation. The tailrotor-driveshaft is usually a lightweight, flexible, segmented, shaft connected with flexible couplings to accommodate misalignment. Furthermore, the driveshaft is mounted on a relatively flexible tailboom structure by contact hanger bearings, see figure 1. Shaft imbalance and angular misalignment are major harmonic excitation sources inherent to the tailrotor driveline. This is especially true in the case of lightweight, super-critical shafting. Furthermore, in various flight conditions, unsteady aerodynamics on the tailboom and horizontal stabilizer cause significant tailboom structural vibration that is transmitted into the drivetrain via the hanger bearings. As a result, hanger bearings and flexible couplings require frequent inspection, lubrication, and replacement in order to maintain airworthiness. Additionally, driveshafts require frequent balancing and alignment to reduce the rotational imbalance and misalignment effects.

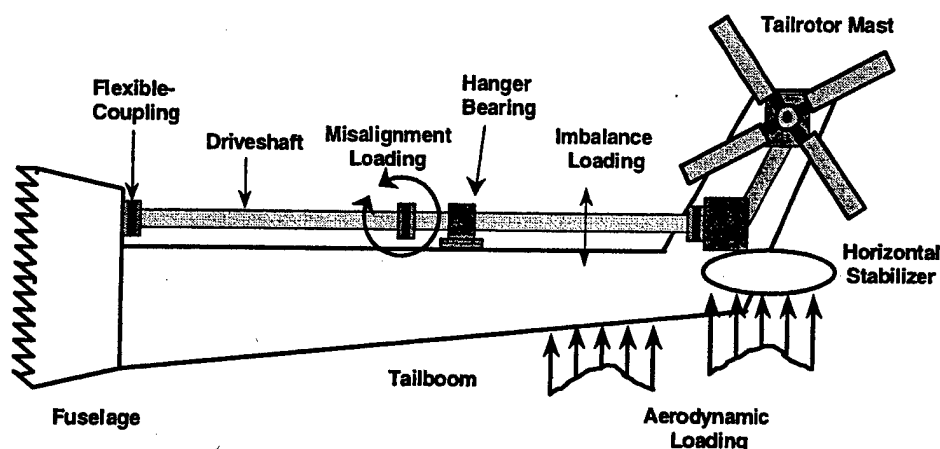

Figure 1. Tailrotor Driveshaft-Airframe Structure and Excitation

Research Objectives

The objective of this research is to develop and evaluate an active vibration control system for a coupled tailrotor driveshaft-airframe structure both analytically and experimentally. Non-Contact, Active Magnetic Bearings (AMB) will serve as actuators for the vibration control system, which will be developed to actively suppress shaft imbalance and misalignment induced vibration, while simultaneously isolating the driveline from tailboom vibration. Other researchers have investigated shaft levitation and suppression of shaft imbalance vibration with magnetic bearings however in the rotorcraft setting, the additional presence of foundation flexibility and angular misalignment make this a unique control problem. Active suppression of imbalance and misalignment induced vibration will reduce the need for frequent shaft balancing and

alignment. Furthermore, by replacing the conventional hanger bearings and external dampers with Non-Contact Magnetic Bearings, frictional wear associated with conventional hanger bearings and dampers will be eliminated thus further reducing driveline maintenance requirements and down time.

Technical Approach & Accomplishments

In order to study the dynamics and develop the active control system for the tailrotor-drivetrain, A finite element model of a coupled fuselage-tailrotor driveshaft structure based on the AH-64 Apache has been developed. The various loading conditions are estimated and modeled. Specifically, the interactional unsteady aerodynamics caused by main rotor blade passage over the tailboom and main rotor vortex impingement on the horizontal stabilizer is estimated for various forward flight conditions. Additionally, shaft imbalance is calculated and a detailed analysis based on non-constant velocity flexible coupling kinematics is performed to obtain the periodic parametric and forcing terms generated by driveline angular misalignment and load torque. Several control laws based on Optimal Control Theory with a hybrid weighting scheme are used to minimize shaft vibration and bearing loads during shaft spin-up and forward flight. An actuator sizing study based on maximum required actuator force, air-gap clearance, magnetic flux saturation limits, and weight is conducted. In order to replace the passive hanger bearings and external dampers to achieve stable magnetic levitation of the driveline, A detailed stability analysis is performed. The destabilizing effects of load torque and misalignment are examined analytically to obtain better guidelines to design the active control. Finally, In order verify the analytical predictions and the effectiveness of the active control, a frequency scaled, Active Magnetic Bearing driveshaft-testrig has been developed. See Figure 2 for a schematic of the experimental testrig.

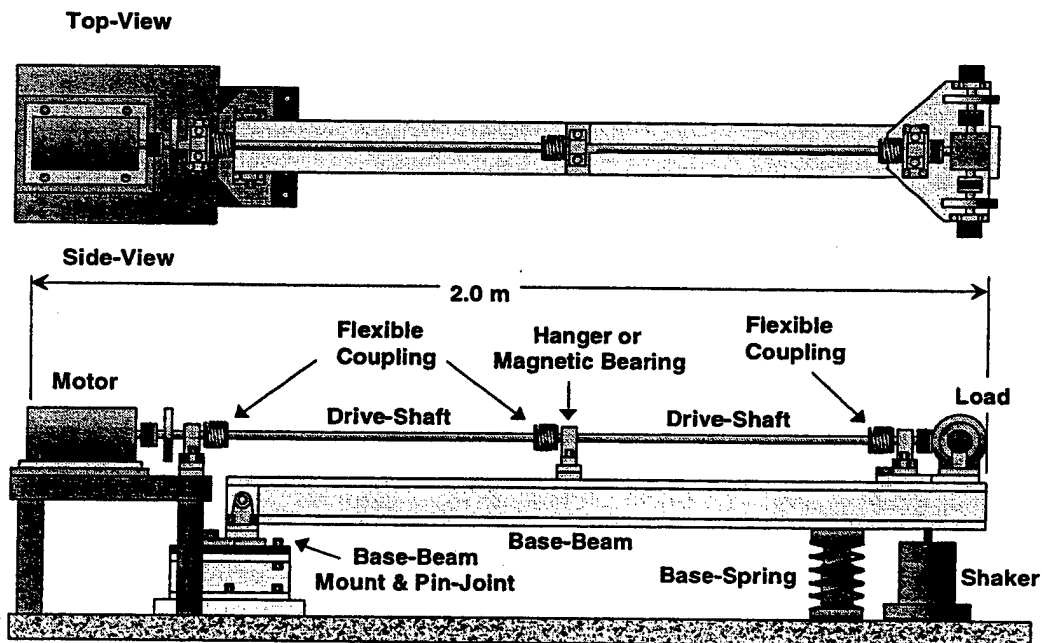

Figure 2. Scaled Helicopter Tailrotor Driveshaft-Airframe Experimental

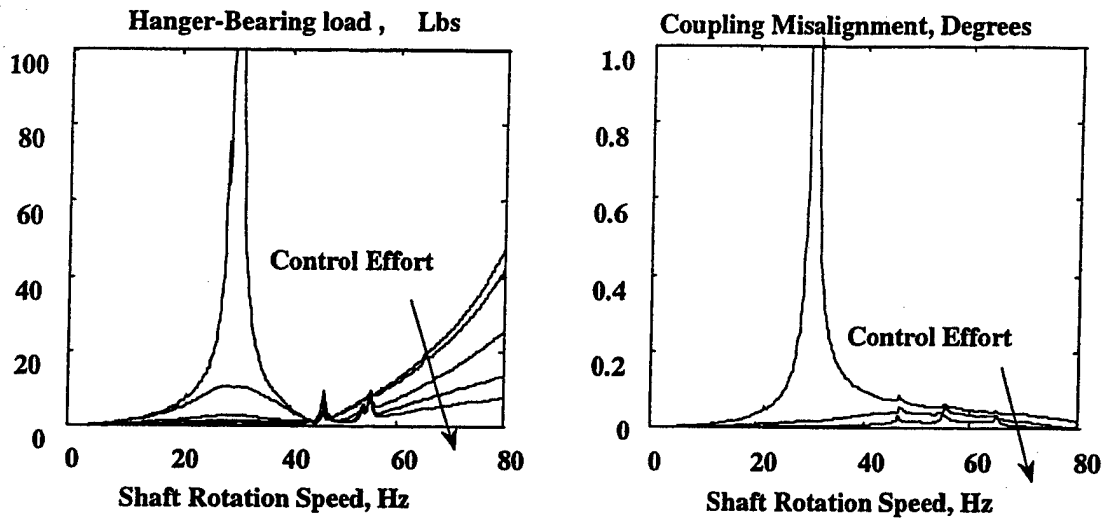

Figure 3. Closed-Loop Hanger Bearing Load and Coupling Misalignment vs. Shaft RPM During Spinup.

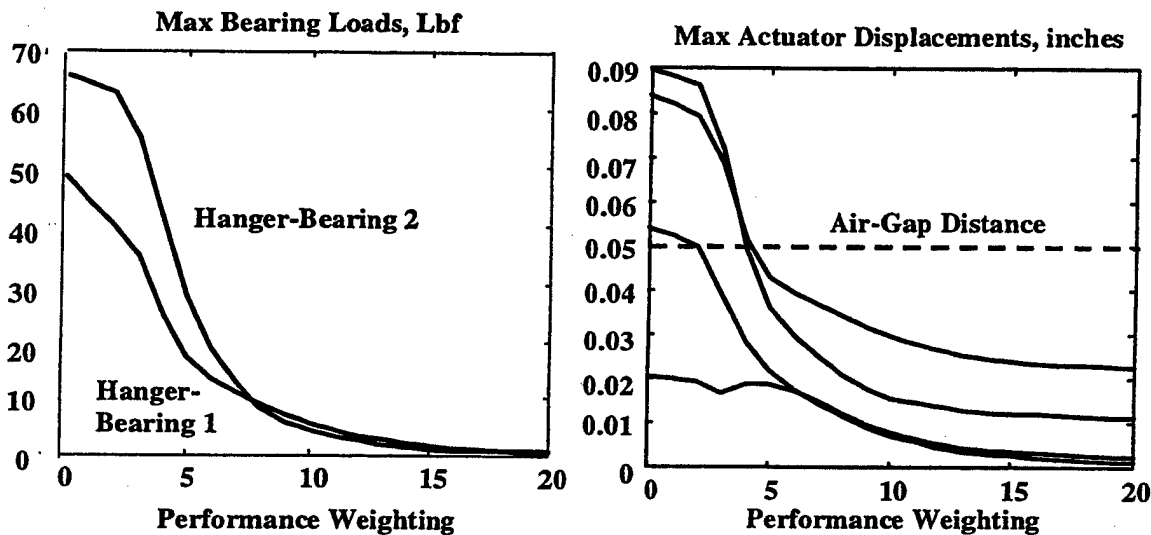

Figure 4. Closed-Loop Hanger-Bearing Load and Shaft-Actuator Airgap Clearance vs. Control Performance Weighting During Forward-Flight Flight.

Future Work

During the final phase of the project, the analytical predictions and the effectiveness of the active control will be evaluated experimentally with the Active Magnetic Bearing driveshaft-testrig. Furthermore, a more advanced Adaptive control law taking into account time varying torque and misalignment coupling terms in addition to the stability boundaries will be developed. Finally an improved actuator sizing study using the new control law will be performed.

Significance

Active vibration control of rotating machinery has been explored and developed by many researchers in the past. In particular, magnetic bearings have been used as actuators because of their many good characteristics (e.g. non-contact, no wear, short time constants, and compactness), and promising results have been shown. Despite this large body of research, the results cannot be directly applied to the tailrotor driveshaft system, since most work only deals with suppression of rotational imbalances of rotating machinery on rigid foundations.

Thus, one main research issue is the effect of tailboom flexibility on the dynamics and control of the tailrotor driveshaft system. Tailboom flexibility dynamically couples the shaft and tailboom, which subjects the shaft to many excitation sources not encountered in an uncoupled system. The shaft is subjected to both a narrow band imbalance excitation and to external tailboom disturbances that are transmitted to the shaft as a result of tailboom flexibility. Furthermore, shaft imbalance forces can excite tailboom vibration modes, which can cause dynamic misalignment of the driveshaft. Because many excitations occur in the neighborhood of the tailboom natural frequencies, dynamic coupling caused by tailboom flexibility is a significant factor which must be addressed in order to develop an effective active vibration control system for the tailrotor driveshaft.

The balance between shaft control authority and shaft isolation must also be investigated. The control algorithm must suppress the rotational imbalance and isolate the shaft from external tailboom disturbances without sacrificing control authority. The control strategy must balance between these two competing strategies. Furthermore, due to the dynamic environment of the rotorcraft, the control system must perform over many different excitation bandwidths.

Another important research issue is the misalignment effect. As the tailboom deflects and vibrates as a result of aerodynamic loading, the segmented driveshaft is misaligned. Static misalignment results from horizontal stabilizer lift and the tailrotor anti-torque moment. Shaft imbalance and unsteady aerodynamic forces, such as main rotor blade passage loading cause dynamic misalignment. Both static and dynamic misalignment cause periodic shaft speed variations depending on the type of flexible couplings used. This variation in shaft RPM causes parametric excitation of the system. Since the shaft is supercritical, both whirl instability due to internal damping and parametric instability due to misalignment and torque must be addressed by the active control.

Finally, actuator sizing and design issues must be addressed. The required control forces must not exceed the limits of the actuators. The control algorithm must be created to operate within reasonable bounds in order not to exceed weight and power requirements associated with rotorcraft.

External Collaborations

NASA Glenn Research Center

- Fellowship Contract (Andrew J. Provenza, Technical Monitor)
- Spent a Week at Facility in Summer 2000 To Work on Magnetic Bearing Design

McDonnell Douglas (Boeing Mesa) Helicopter Systems, (Deshner, Hansen, Meyyappa, Stemple, Toosi)

- Visited & Discussed Concept, Summer 1998 & April 1999

US Army Propulsion Directorate at NASA Lewis (Bill, Kascak, Brown)

- Visited & Discussed Concept, Summer 1998 & April 1999

NASA Ames

- Visited & Presented Ideas, Summer 1998

Sikorsky Aircraft (Jerry Miao) & Lord Corporation (Pat Sheridan)

- Topic Formulation

Publications

DeSmidt, H. A., Wang, K. W., and Smith, E. C., "Active Vibration Control of Rotorcraft Driveshaft-Airframe Dynamics," published in *Proceeding of the 54th American Helicopter Society Annual Forum*, Washington, D.C., May 20-22, 1998.

Task 4.2

Active Gearbox Struts for Control of Noise/Vibration Transmission

I. Pelinescu and B. Balachandran
Department of Mechanical Engineering
University of Maryland
College Park, MD 20742-3035

Research Objectives

The overall aim of this task is to develop models and schemes for controlling noise/vibration transmission through helicopter gearbox struts. Specific objectives include the following: a) development of mechanics based models for mechanisms of noise/vibration transmission through finite length strut-like structures including integration of actuation schemes and b) investigation and validation of schemes to control noise/vibration transmission through strut-like structures over different frequency bandwidths.

Approach

Efforts have been primarily directed along two main directions. In one direction, a mechanics based approach has been used to develop models for active integrated strut system for control of uncoupled longitudinal and flexural wave transmission through cylindrical members representative of helicopter gearbox struts. Along the other direction, a laboratory scale experimental arrangement has been developed for studying the control of waves transmission in a hollow cylindrical strut (Figure 1). The experiments are guided by predictions from the previously developed mechanics based model. In the experiments the strut (Figure 2a) is subjected to static axial tension forces and vibratory loads applied along longitudinal and transverse directions. Piezoelectric stack actuators in inertial configurations are attached to the strut so as to provide control input forces along longitudinal and transverse directions. Arrangements of single and pair actuators are used in conducting open-loop vibration cancellation studies (e.g., Figures 2b & 2c). The cylindrical strut is instrumented with stress/strain, acceleration, and force sensors. A finite element model of the strut has been developed and used to analyze its spectral properties, and modal testing has been performed with the experimental model (e.g., Figure 3).

Accomplishments

Results of finite element analysis and experiments provide a clear indication of the coupling between longitudinal and bending modes of vibrations of the cylindrical strut. However, this coupling is not always readily detected and this depends on the sensor system used. Longitudinal harmonic vibratory disturbances with magnitudes of up to 8 lbf have been transmitted through the cylindrical strut close to the resonance frequencies of the system, and the actuator has been driven with appropriate amplitude and phase in a manner similar to that described in our previous analytical work. In the analog, open-loop experiments, a reduction of up to 30 dB in the acceleration level of vibration transmission has been achieved at the strut end upstream of the disturbance (e.g., Figure 4). A good correspondence has been found between analysis and experiments regarding the manner in which the piezoelectric stack actuators have to be driven in order to reduce harmonic disturbances transmitted through the strut.

Future Work

Future work will include the implementation of digital feedforward and feedback control methods to reduce longitudinal and flexural waves transmitted through the cylindrical strut. The model of the strut-actuator system will be further developed to account for the coupling between different modes of vibrations. Testing and characterization studies of different types and configurations of actuators/sensors systems including magnetostrictive actuators and embedded fiber optic sensors are also planned.

Significance

High frequency tones inside a helicopter cabin are primarily due to structure-borne noise transmission through the gearbox struts. The outcome of this task will help understand the importance of controlling flexural wave transmission and longitudinal wave transmission in the context of helicopter gearbox struts. Furthermore, the outcome of this task will demonstrate the viability of using active materials for controlling noise/vibration transmission through gearbox struts into rotorcraft cabins.

External Interactions

This task has benefited from interactions with Mr. William Welsh and Dr. Thomas Millott of the Sikorsky Helicopters and Mr. Douglas Ortel of the Lockheed Martin. The research has also benefited from interactions with Dr. Lutz Pickelmann of Piezomechanik GmgH on the use of stack actuators and Mr. Bob Clifford of Etrema Incorporated on the use of magnetostrictive actuators.

Publications

I. Pelinescu, B. Balachandran, and D. Ortel, "Active Control of Wave Transmission Through Struts", Proceedings of ARO's 4th Workshop on Smart Structures, 16-18 August 1999, Pennsylvania State University, PA.

I. Pelinescu and B. Balachandran, "Analytical Study of Active Control of Wave Transmission Through Cylindrical Struts", Journal of Smart Materials and Structures, Special Issue on Rotorcraft Applications (accepted for publication).

I. Pelinescu and B. Balachandran, "Analytical and Experimental Investigations Into Active Control of Wave Transmission Through Gearbox Struts", Proceedings of SPIE's 7th Annual International Symposium on Smart Structures and Materials: Smart Structures and Integrated Systems, 5-9 March 2000, Newport Beach, CA, Paper No. 3985-07, Vol. 3985.

I. Pelinescu and B. Balachandran, "Experimental Study of Active Control of Wave Transmission Through Hollow Cylindrical Struts", Abstract submitted to SPIE's 8th Annual International Symposium on Smart Structures and Materials: Smart Structures and Integrated Systems, 4-8 March 2001, Newport Beach, CA.

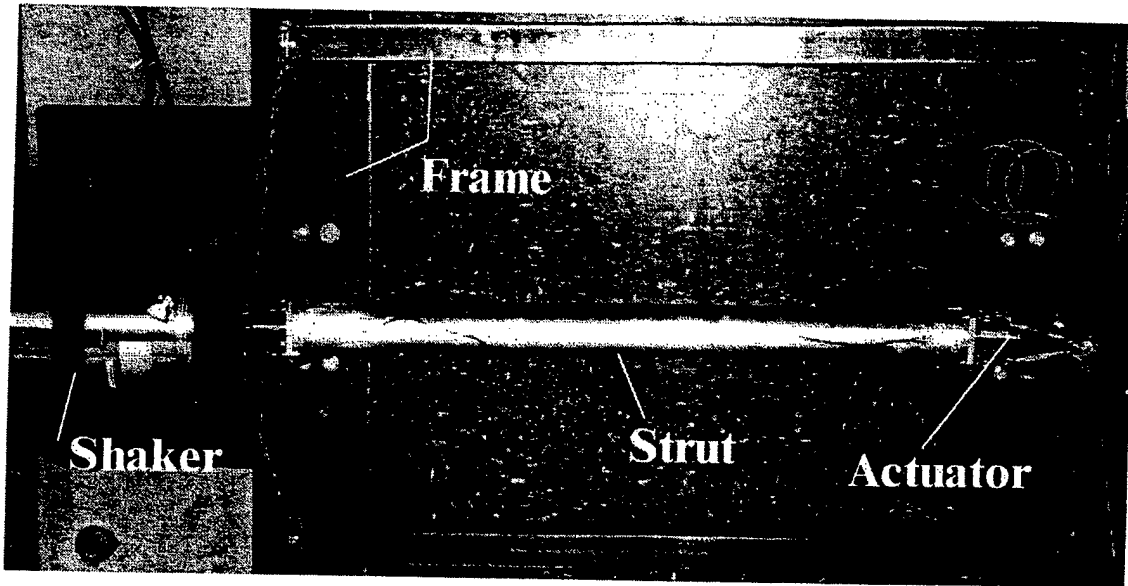
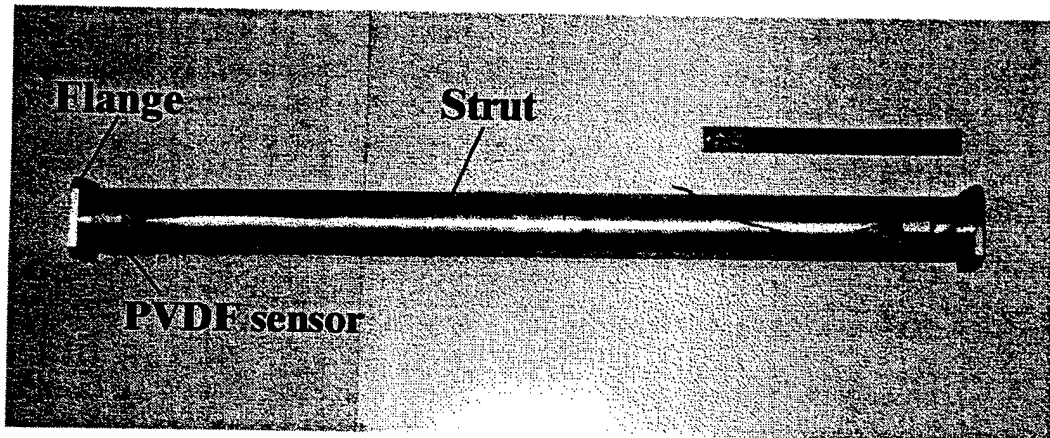
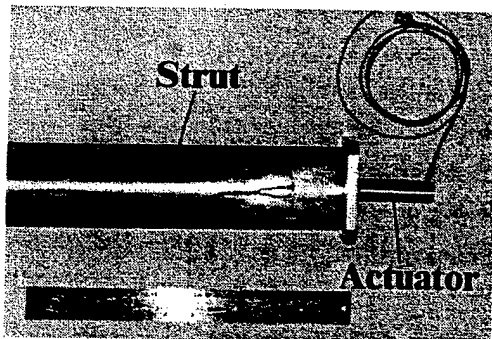

Figure 1: Experimental arrangement for control of longitudinal vibration transmission.



(a)



(b)

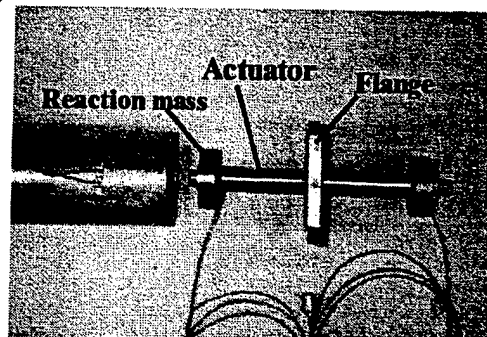

(c)

Figure 2: Experimental arrangement: (a) cylindrical strut and (b) & (c) piezoelectric actuator arrangements.

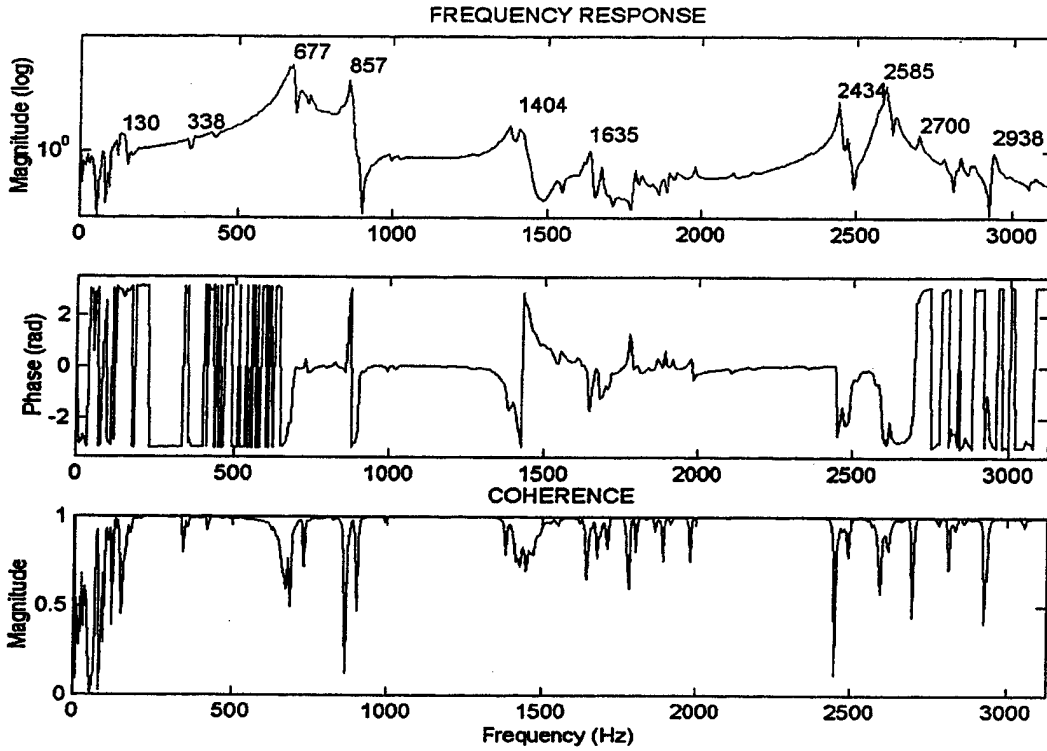

Figure 3: Experimental modal testing using dynamic axial loading of the cylindrical strut.

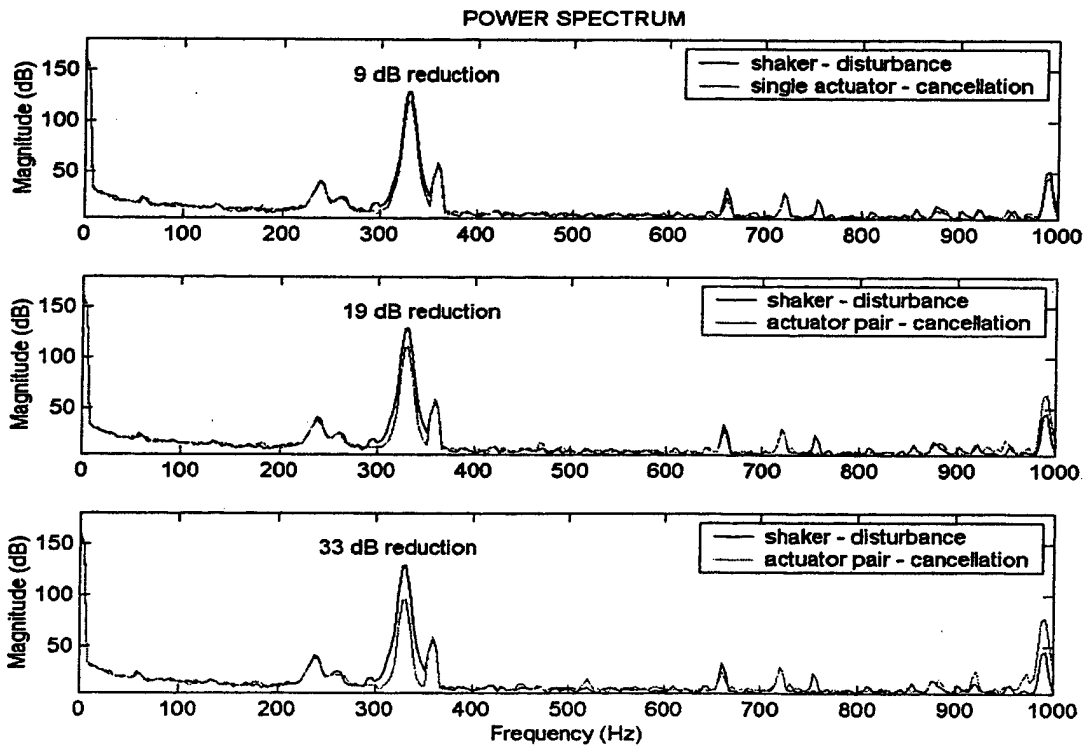

Figure 4: Spectra of accelerometer measurements at the right end of the strut. Longitudinal vibratory disturbance acting at the left end of the strut: 8 lbf @330 Hz.

Task 4.3: Adaptive Multi-Functional Sensors for Transmission Noise Suppression

D. J. Pines, A. A. Hood
Alfred Gessow Rotorcraft Center
Smart Structures Laboratory
University of Maryland

Research Objective

To develop adaptive, multi-functional sensors to detect sources of acoustic and structure-borne noise from helicopter transmissions. Specifically, this work will involve the development of a multi-functional sensor that can sense strain, acoustic pressure, and temperature to compensate for environmental changes. Sensors will be arranged in the form of an array to adaptively steer the directional sensitivity pattern.

Technical Approach

Maryland will develop an adaptive distributed sensing array configuration consisting of PVDF sensors, strain gage rosettes, and thin film thermocouples. These elements will be integrated as a flexible skin for sensing acoustic and structure-borne signatures from geartrain drive dynamics. The envisioned sensors will have multi-layer structure in which the PVDF film will have a thin thermocouple sputtered on its top and a thin film strain gage sputtered on its bottom face. Through appropriate post-processing, this sensor will enable simultaneous measurements of acoustic pressure, temperature, and in-plane strains. While monitoring gearbox dynamics, this sensor will also be able to identify acoustic signatures generated from drivetrain dynamics.

Accomplishments

Several sensor array configurations have been simulated to study acoustic pressure directional sensitivity (See Figure 1). Several differential acoustic pressure sensors utilizing off-the-shelf microphones were used to measure directional sensitivity patterns. Results using these sensors are encouraging and suggest that adaptive directional sensing is possible.

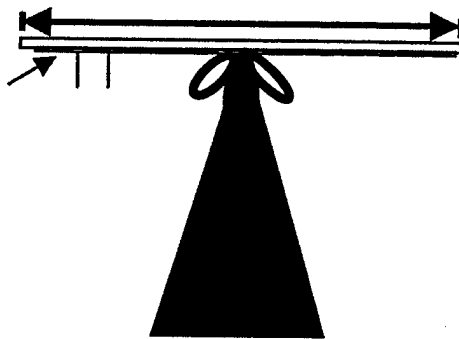

Figure 1: Beam Width of Linear Array

Experimental results are obtained using the University of Maryland Transmission Test Rig with a linear acoustic array. Measured sensitivity of the directional array is displayed in Figure 2 using 30 acoustic sensors with a spatial resolution of 0.6 inches.

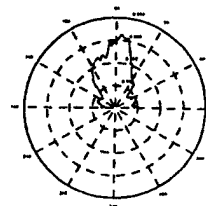

Figure 2: Directional Sensitivity

Future Work

Refinement and modeling of acoustic sensors. Modeling structure-borne vibration and acoustic radiation from a single panel of a gearbox. Utilize sensor array for health monitoring of transmission systems.

In helicopter noise geartrain transmission system, unwanted noise can arise due to structure-borne and acoustic noise sources. This research will help to identify these noise sources and their frequency content by developing a sensor that is sensitive to both noise modes. It is anticipated that such a sensor would help to assess appropriate vibration noise control strategies for reducing acoustic signatures. In addition, a multi-functional sensor would be extremely useful to Health and Usage Monitoring of geartrain transmission dynamics.

External Collaboration

Khan Nguyen of NASA Ames has an interest in using these sensors for BVI noise reduction. James, Zakrajsek, and Dave Lewicki are interested in using these sensors for fault detection in the transmission system. This is coupled strongly with NRTC Task 5.1 (Fault Detection of and Reconfiguration Rotorcraft Transmission Systems).

Task 5.1 - Use of Dissimilar Rotors for BVI Noise Reduction

Prof. Farhan Gandhi

Objective

To analytically determine the influence of balanced blade-to-blade dissimilarity (blades 1 & 3 - identical; blades 2 & 4 - identical, but different from 1 & 3) for reducing Blade-Vortex Interaction noise (and associated vibrations) in low-speed and descending flight conditions.

Motivation

BVI noise one of the most serious problem faced by helicopters, with repercussions on community acceptance, detectability for military applications, and personnel and structural fatigue. Although several concepts have been under consideration to reduce BVI, a generally accepted solution has been elusive. In the 60s and 70s, the Variable Geometry Rotor (VGR) program demonstrated that blade-to-blade dissimilarities had a strong impact on the strength and trajectories of the tip vortices. Thus, it is reasonable to expect that optimally designed dissimilarities could reduce BVI. Additionally, the Sikorsky Variable Diameter Tiltrotor (VDTR) concept offers the potential of individually varying the lengths of specific blades. Their (patented) in-house studies on use of dissimilar blade lengths to reduce BVI appear promising.

Approach

A free-wake analysis is implemented in-house at the Penn State University. This is coupled with BVI detection methods to determine the occurrence and intensity of parallel BVI in any flight condition. The free-wake formulation is extended to predict the trajectory and strength of the tip vortices of a rotor with dissimilar blades. The BVI characteristics for a rotor with dissimilar blades are to be examined at various forward speeds and descent rates. Emphasis is to be placed on developing a physical understanding of the mechanisms by which reductions in BVI noise are achieved for dissimilar rotor designs. The high-resolution blade loading due to the rotor wake is used as an input in the NASA-Langley aeroacoustic code WOPWOP to calculate the acoustic pressure histories, and the BVI sound pressure levels on an observer plane below the rotor. A thorough parametric study examining the influence of various design parameters on BVI characteristics, is to be followed by an optimization procedure to determine an "optimal" dissimilar rotor design for BVI alleviation in low-speed descent.

Accomplishments

Year 1 - A refined free-wake analysis was implemented in-house. The predicted wake geometry and inflow at the rotor was validated with the MFW analysis as well as experiment to provide confidence in the implementation. A new BVI detection method - *the spherical method* - was developed, and predictions using this method were validated with experiment.

Year 2 - First, a comparison of various numerical BVI detection schemes was conducted. An in-depth understanding was obtained about the relative strengths and weaknesses of various schemes. For example, the *planar detection or miss-distance method* needs a very high-resolution azimuthal discretization to detect parallel BVI, and considerable post-processing of wake data. The *spherical method* is able to identify parallel BVI using low-resolution azimuthal discretization and requires no post-processing of wake data. Detection of parallel BVI using *inflow or blade loads*, is not possible if the vortex diffusion rate is too high (core growth too quick). Next, the Free-Wake analysis was extended to model the vortices of a rotor with dissimilar blades (Fig. 1). This involved the simultaneous calculation of the trajectories of the vortices of the two sets of blades (since they mutually influence each other), and consequently, a doubling of the problem size.

Year 3 - BVI characteristics at a moderate descent rate were examined for two rotors with dissimilar blade lengths. For the first rotor, the length of two blades was 80% of the baseline radius (80% rotor). For the second, the length of two blades was 95% of the baseline rotor (95% rotor). For both dissimilar rotors, the BVI airloads on the advancing side were less impulsive in nature (Fig. 2 compares the airloads for the baseline rotor as well as the long and short blades of the 80% rotor). Peak BVI noise reductions of 4 dB (for the 80% rotor) and 4.8 dB (for the 95% rotor) were obtained over the baseline, with significant changes in the noise directivity pattern (Fig. 3). The reduced BVI of the 80% rotor was directly related to the differential coning of the shorter and longer blades. This results in tip vortices being released in different planes and the parallel interactions having increased miss-distances. Although dissimilarity produces two-per-rev hub vibrations, initial calculations suggest that these will be *smaller than the four-per-rev vibrations of the baseline rotor*.

Year 4 – Having understood that the mechanism by which the 80% rotor reduced BVI noise was through increased miss-distances due to split tip-path-planes, dissimilarity in blade pitch between two sets of blades was considered next. It was felt that this could achieve a similar split in tip-path-plane and would hence result in noise reductions (while being easier to implement). However, simulations indicated that this resulted in a drastic change in the overall blade-vortex-interactions; making it difficult to pinpoint mechanisms at work and difficult to exploit. In fact, for the high BVI flight condition considered, the noise actually increased slightly. Attempts to understand the mechanism by which the 95% rotor resulted in larger BVI noise reductions (4.8 dB as compared to 4 dB for the 80% rotor) indicated a very complex BVI pattern and the occurrence of vortex pairing. The third major thrust area in Year 4 focused on decomposition of BVI noise. It is known that several individual close, near-parallel BVI events on the advancing side (as well as the retreating side) contribute to the total BVI noise. A methodology was developed and implemented to calculate the individual contributions of each event. After computing the free-wake geometry, the blade loading and associated BVI noise was calculated by considering one vortex at a time (see Fig. 4). Using such a procedure the acoustically dominant interactions can be identified without ambiguity, and this information can be used to track the changes in individual BVI events when any BVI alleviation scheme is used. It was further shown that the impulsive blade loads, acoustic pressure histories, and BVI noise can be accurately predicted by considering only the vortex segments producing close near-parallel interactions in the 1st and 4th quadrants (rather than the *entire* tip vortices).

Future Plans

Year 5 – Introduce blade elasticity into the model and calculate vibratory loads in BVI conditions. Validation of BVI predictions with HART test data. Application of decomposition method developed in Year 4 to HART data to obtain very detailed understanding of noise reduction mechanisms. Identify the acoustically dominant interactions and track how the Higher Harmonic blade pitch inputs modified each of these interactions.

External Collaboration

- Dr. Ken Brentner (NASA-LaRC) - questions related to WOPWOP.
- Prof. Baeder and Dr. Yung Yu - technical progress and future directions of the project.
- Dr. Wayne Mantay (Army-LaRC) - discussions on influence of dissimilarity
- Dr. Mike Torok and Mr. Robert Moffitt (Sikorsky) – discussion of Sikorsky VDTR results.
- Dr. Scott Hirsh (Boeing Philly), Dr. Ram Janakiram and Mr. Bruce Charles (Boeing Mesa) – general discussions.

Publications and Technology Transfer

Tauszig, L., "Numerical Detection and Characterization of Blade-Vortex Interactions Using a Free-Wake Analysis," MS Thesis, Department of Aerospace Engineering, The Pennsylvania State University, July 1998.

Gandhi, F., and Tauszig, L., "A Critical Evaluation of Various Approaches for the Numerical Detection of Helicopter Blade-Vortex Interactions." *Journal of the American Helicopter Society*, Vol. 45, No. 3, July 2000, pp. 179-190.

Tauszig, L., and Gandhi, F., "Influence of Blade-to-Blade Dissimilarities on the Alleviation of Blade-Vortex Interactions," accepted for publication in *Mathematical and Computer Modelling*, March 2000.

Gandhi, F., and Tauszig, L., "Influence of Individual Interactions on Helicopter Blade-Vortex Interaction Noise," *Proceedings of the 26th European Rotorcraft Forum*, Sept. 26-29, 2000, The Hague, The Netherlands.

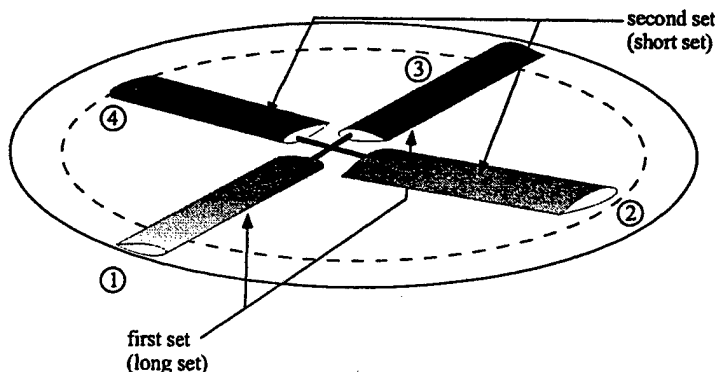

Figure 1. Dissimilar rotor

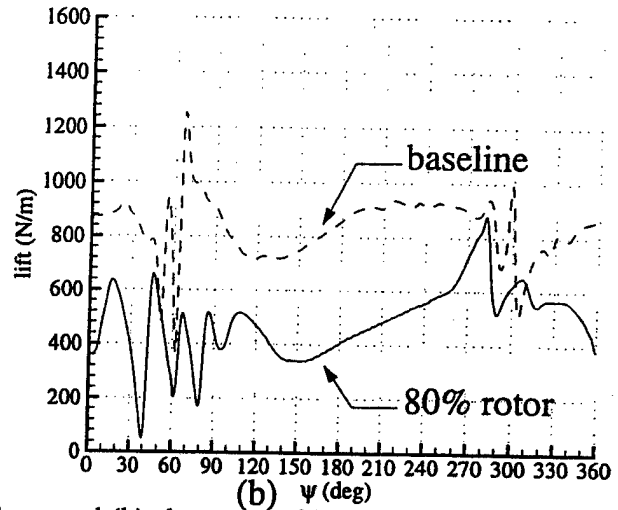
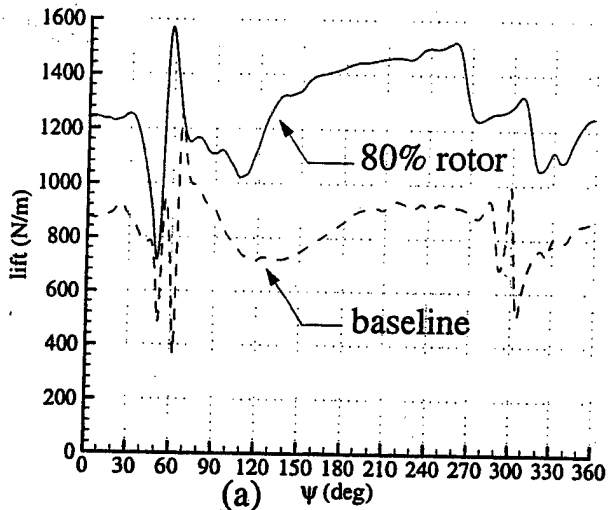

Figure 2. Lift at 75% radius for (a) long and (b) short sets of blades

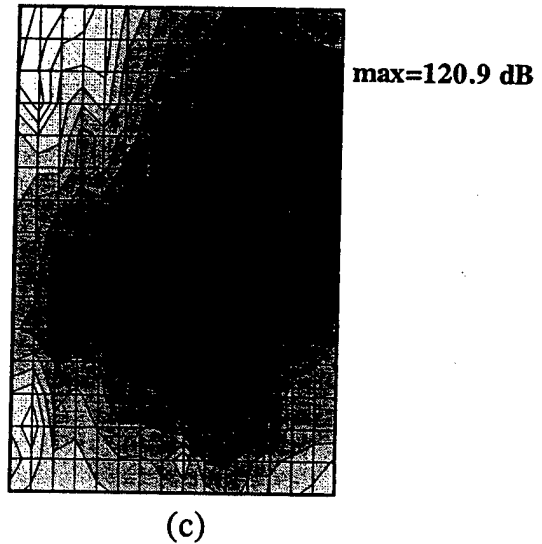
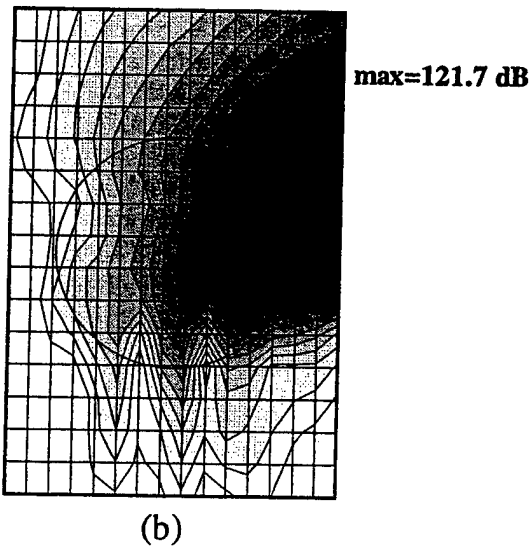
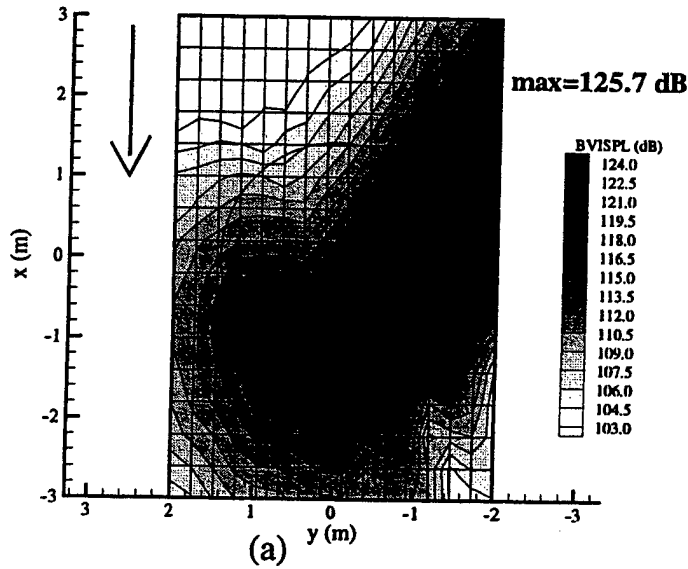

Figure 3. BVI Sound pressure level for (a) baseline, (b) 80% and (c) 95% rotor

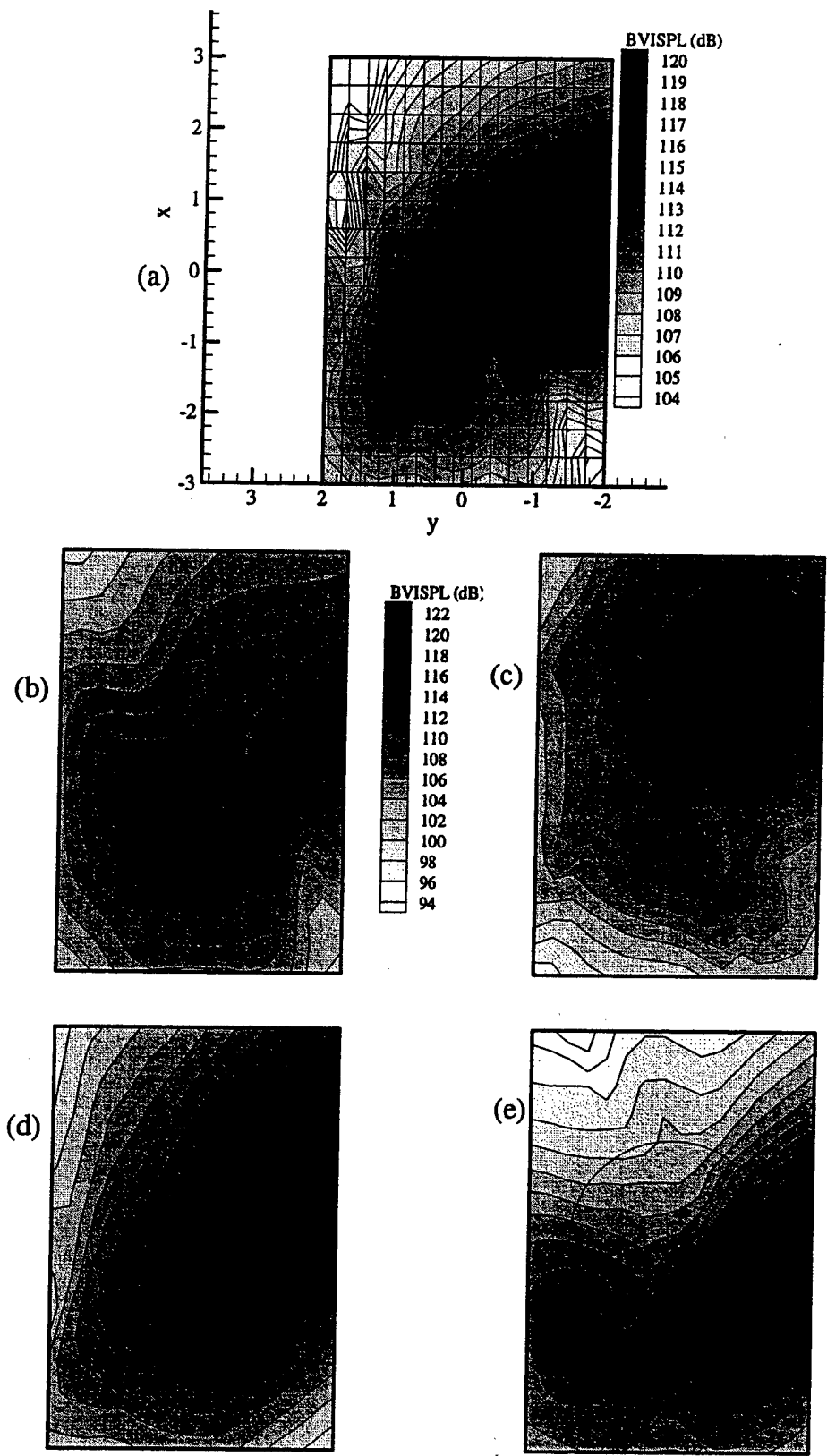

Figure 4: Noise (BVISPL) generated by the loading from (a) all the tip vortices (entire wake) (b) tip vortex from reference blade, k-0, (c) tip vortex from previous blade, k-1, (d) tip vortex from opposite blade, k-2, and (e) tip vortex from k-3.

Task 5.2

Hybrid Actuators and Power Minimization

Jayant Sirohi and Inderjit Chopra

Alfred Gessow Rotorcraft Center
Department of Aerospace Engineering
University of Maryland

Research Objective

To develop a compact hydraulic actuator driven by a piezoelectric pump to satisfy actuation requirements for a trailing edge flap in a smart rotor.

Motivation

Piezoceramic stacks are potential actuators for a wide range of applications due to their high frequency and block force capability. In utilizing piezostack mechanisms in smart rotor applications, the major barrier is the small stroke of the actuator. To overcome this, amplification mechanisms have to be designed, which contain many moving parts. These moving parts contribute to actuation losses and also undergo high stresses due to the large centrifugal forces on the blade. To overcome these problems, the use of a hydraulic actuator driven by a piezoceramic stack operating at a high frequency is envisaged.

Approach and Accomplishments

The hybrid piezoelectric – hydraulic actuator is a stepwise actuation concept to provide actuation at both large force and stroke. A piezoceramic stack actuator that deforms a membrane and displaces a hydraulic fluid creates a hydraulic pump. The high frequency capability of stacks is exploited in order to obtain the required flow rates, though the per cycle volumetric displacement of the pump is low as a result of the small displacements of the stack. The theoretical efficiency of such a system can be shown to be twice that of a piezoelectric actuator driving a simple spring type load.

The pump consists of two piezostacks driving a piston-membrane system (Fig. 1). The design goals of the actuator coupled to the pump are shown in Fig. 2. The first prototype of the pump has been designed and fabricated (Fig. 3) and is currently undergoing testing. A major problem with high frequency operation of the device is the large current consumption. An L-C oscillator circuit is being investigated to reduce the current consumption (Fig. 4). Additionally, the feasibility of replacing all the mechanical valves with active magneto-rheological valves is being investigated, in order to achieve a system with no moving parts.

Future Plans

1. Testing of the first piezostack driven pump prototype.
2. Scaling design parameters in order to achieve design goals.
3. Construction of active L-C oscillator circuit to reduce current consumption.
4. Investigation of active magneto-rheological valving concept.

Publications

1. Sirohi, J. and Chopra, I., "Actuator Power Reduction using L-C Oscillator Circuits," *Proceedings of the 41st Structures, Structural Dynamics and Materials Conference and Adaptive Structures Forum*, (Atlanta, GA), April 2000. AIAA-2000-1791.
2. Sirohi, J. and Chopra, I., 'Fundamental Behavior of Piezoceramic Sheet Actuators', *Proceedings of the 5th Annual International Symposium on Smart Structures and Materials*, 3-5 March 1998, San Diego, CA.

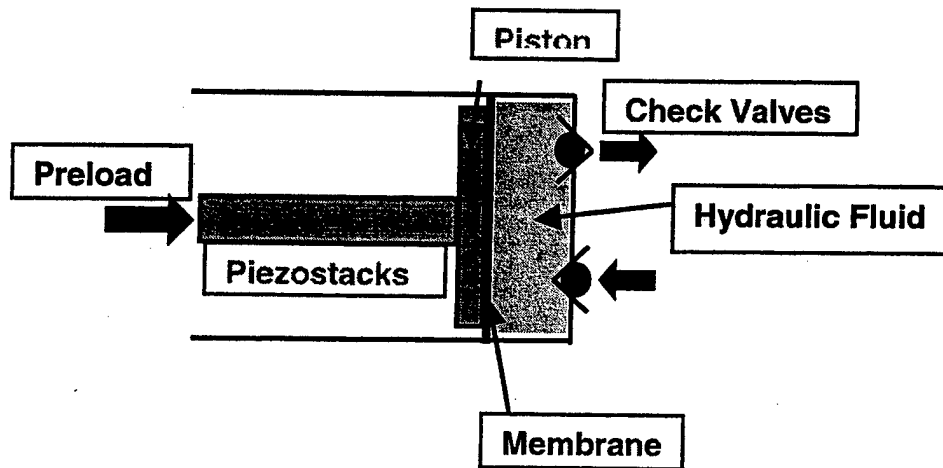

Figure 1 Schematic of piezostack driven hydraulic pump

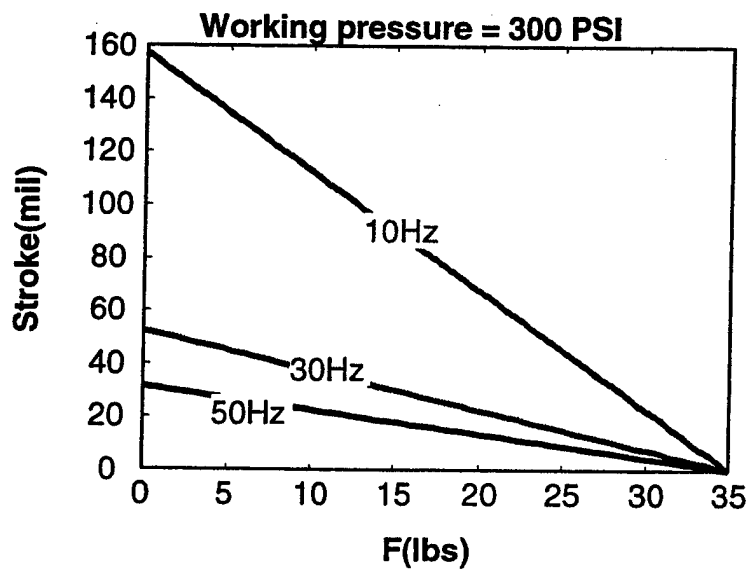

Figure 2 Actuator design goal

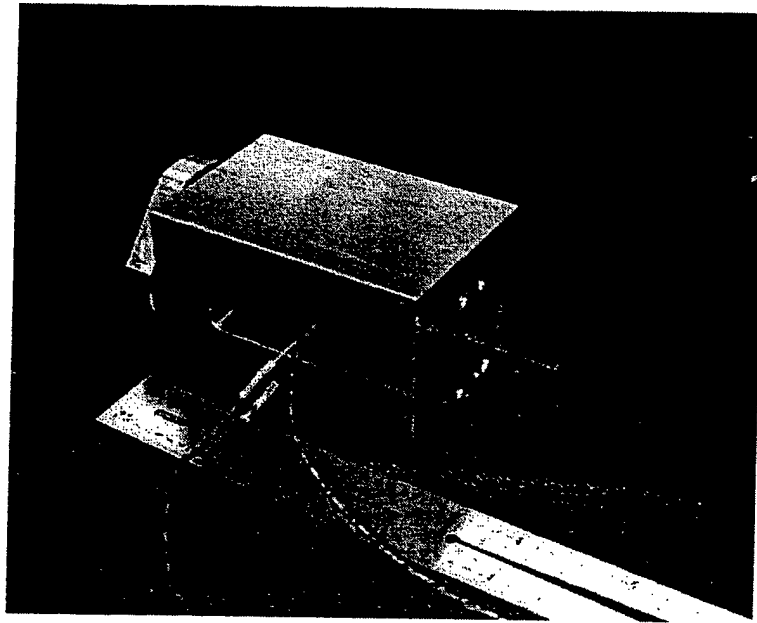

Figure 3 First Prototype

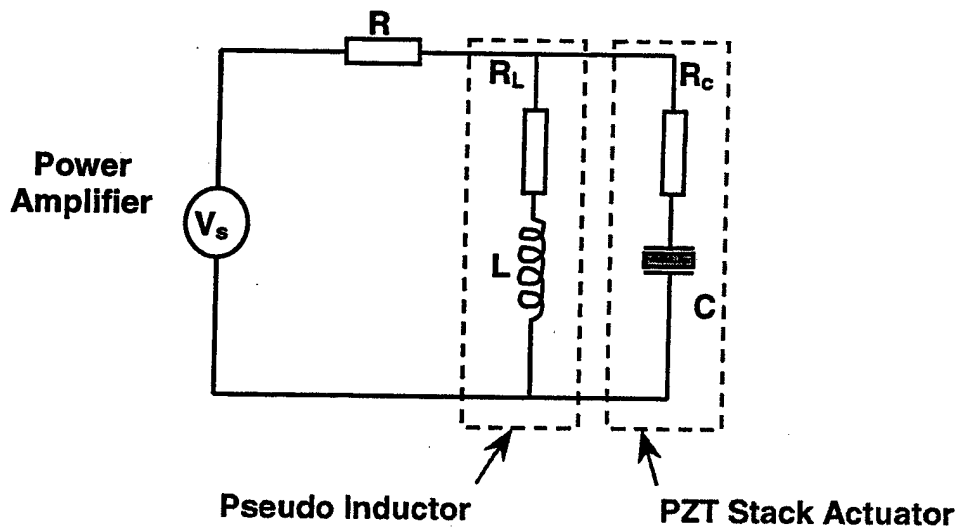

Figure 4 Current reduction circuit

Task 6.1

Fabry-Perot sensor system for acoustic measurements

Miao Yu, Dr. Steve Chen

Objective:

The goal of this research is to develop a multiplexed, distributed sensor array and adaptive multi-input and multi-output (MIMO) feed-forward control system to create multiple quiet zones within the interior of rotorcraft cabins. The sensor system will provide reference and error sensor signals for the MIMO control scheme. The specific objectives include: 1) Develop multiplex architecture for 4-8 multiplexed optical sensors with a 6kHz bandwidth. 2) Develop SDM architectures using optical switching techniques to extend (on an "area-by-area" basis) the number of sensors. 3) Develop a MIMO control system that can be used to create large quiet zones.

Approach:

This research has been concentrated on developing optical acoustic pressure sensors and developing multiplexed sensor architectures. A Bragg grating cavity based system was demonstrated in 1999 report, which has the advantage that multiple sensors are serially multiplexible along a single fiber. The sensor bandwidth, however, is limited to 500Hz due to the minimum bend radius of optical fiber. To solve this problem, we have been refocusing our effort on developing a new fiber tip Fabry-Perot configuration for the sensor in the past year. The sensor system consists of Fabry-Perot sensors, integrated optics based phase modulator and high-speed optical detectors. The sensing system will use low coherence path matched interferometric techniques to read-out the sensor data. The optical signal is then transmitted to a photo detector. The last step is to develop MIMO control scheme (in conjunction with other MURI subtasks) using an adaptive feed forward scheme that uses multiple reference sensors.

Accomplishments:

- A new prototype sensor system, shown in Figure1, was fabricated instead of the previous Bragg grating Fabry-Perot sensor system. In this setup, a fiber tip Fabry-Perot sensor was built using a TiO₂-coated fiber and a pressure sensitive diaphragm. Under sound pressure, the diaphragm deforms and introduces phase change, which is proportional to the distance change between the fiber tip and the diaphragm and can be detected by interferometry. Compared to the previous Bragg grating sensor, the diaphragm can be much smaller. So the frequency range can be boosted to 6kHz.
- A commercial integrated phase modulator, which has a Mach-Zehnder interferometer inside, was introduced to the sensor system. Two calibration methods, curve fitting and Carre phase stepping method, have been used to get the calibration curve (shown in Figure2). The linearity of the calibration curve indicates that the integrated phase modulator can be used in the optical sensor system.
- Three different phase demodulator algorithms are evaluated and a new digital demodulation scheme based on four-step phase stepping algorithm is developed. Compared to the Carre phase stepping algorithm, it improves the sensor sample rate and has less phase error. The resolution of such a scheme is evaluated using computer simulation.
- The basic characteristics of above prototype have been tested experimentally on bench-top using a calibrated condenser microphone as the reference sensor. Measurements for sound signals at the frequency up to 6kHz have been successfully demonstrated (Shown in Figure4). Based on the

calculation, the system has capability to achieve the bandwidth of 16kHz. And the system sensitivity is 0.09rad/Pa (shown in Figure 5).

- A mathematical model of the dynamical behavior of the diaphragm has been constructed to predict the relationship between the physical dimension of the diaphragm and the bandwidth of the sensor response.
- A high-speed and high signal-to-noise ratio detector is developed to replace the commercial optical detector.
- A star network topology has been constructed to realize the sensor multiplexing (Shown in Figure 3).

Future work:

First, we will build the multi-channel high-speed detector, which is necessary to the multi-channel high frequency measurements. Second, we will focus on testing the multiplexed fiber tip Fabry-Perot sensors with the star network topology. Third, the multiplexed sensor system will be tested in the acoustic chamber test bed at the Vibrations Laboratory at the University of Maryland. During the same period, control methodologies for the multi-input, multi-output system will be analytically tested using models developed in previous research. The multiplexed sensor system will then be implemented with the developed control methodology for experimental evaluation on the acoustic chamber test bed. Finally, the reduction of the interior cabin noise will be realized using multiplexed, high bandwidth Fabry-Perot based fiber optic sensors with a multi-input, multi-output adaptive control scheme.

Significance:

This research demonstrates the feasibility of using a multiplexed, high bandwidth Fabry-Perot based fiber optic sensor system in adaptive interior noise control. One key development from this research will be developing the multiplexed sensor system using the Fabry-Perot sensor configuration. The challenge in this system will be in providing sufficient bandwidth for all sensors, as well as in keeping a low level of cross talk between each multiplexed sensor. Another key development from this research will be the area-by-area sensing and control techniques. By use of a fiber optic switch, various aspects of the interior acoustic pressure field can be monitored. This creates a flexible sensing system to be used for interior noise control. This sensor architecture will enable new active noise control schemes to be explored in which the control schemes may interactively and autonomously drive the selection of where pressure should be monitored for optimum cabin noise suppression.

External Collaboration:

Bragg grating device fabrication will be done in cooperation with NRL (Joe Friebele) and 3M (Harmeet Singh and Gary Ball). Sensor demodulator and multiplexing will benefit from interactions with Micron Optics (Cal Miller) and ElectroPhotonics (Tino Alavie). Lockheed Martin (E.J. Zisk) has expressed interest in commercialization of the multiplexed sensor system. The control scheme development utilizing multi-inputs will benefit from interactions with NASA/Langley (Ruth Martin and Richard Silcox) and MDHS (Seth Dawson).

Publications:

1. Chris Baldwin "Control of Sound in a Three Dimensional Enclosure Using a Distributed Bragg Grating Sensor Array" Ph.D. Proposal, University of Maryland, 1997.
2. C. Baldwin, M. Yu, C. Miller, S. Chen, J. Sirkis, "Optical fiber sound field sensor", International Symposium on Smart Structures and Materials, Newport Beach, USA, SPIE Proceedings Vol. 3670, March 1999.

Some representative figures:

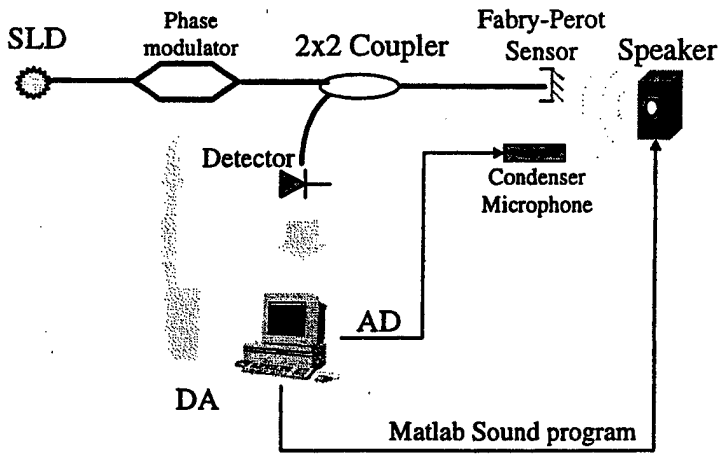

Figure1 Fabry-Perot sensor system

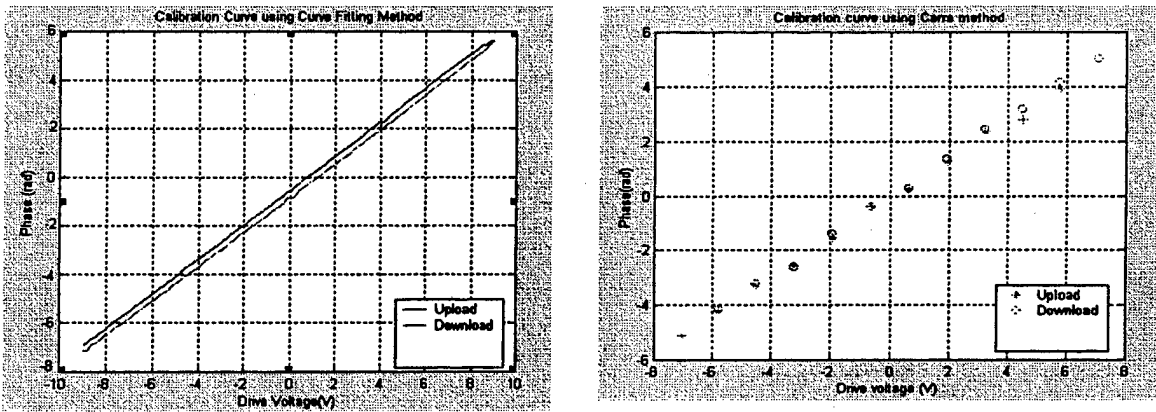

Figure 2 Calibration curves using two different methods

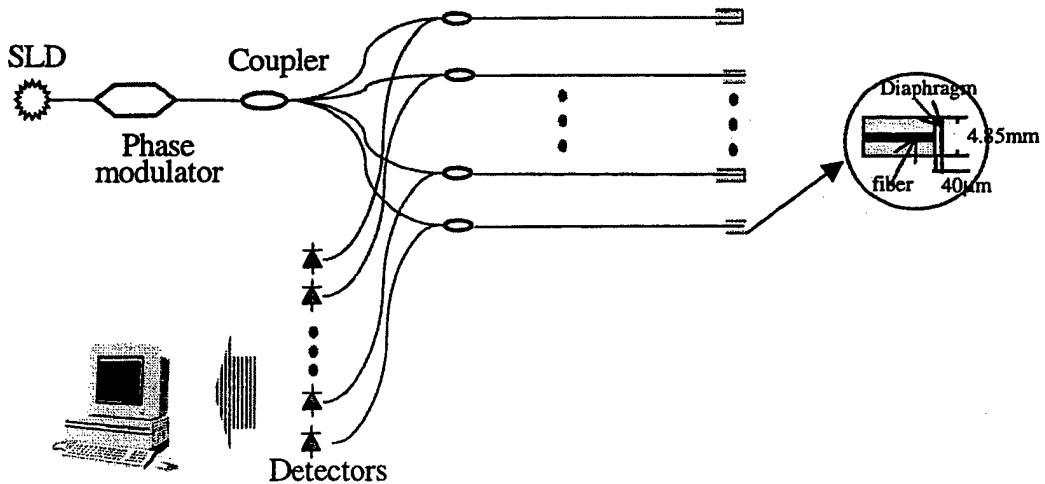
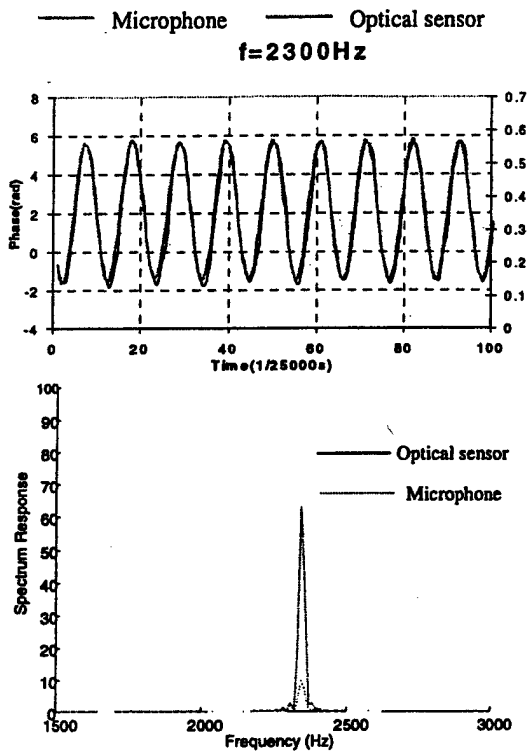
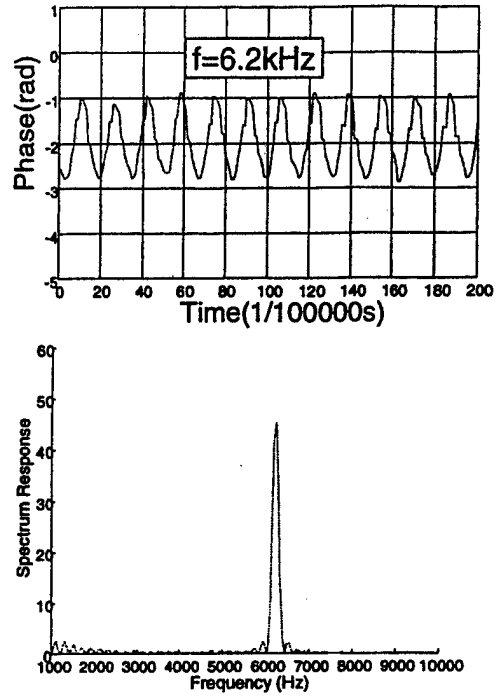

Figure 3 Sensor multiplexing using a star network topology



(a) Optical sensor signal compare to microphone signal at 2300Hz



(b) Generated by Piezo speaker, optical sensor signal at 6.2kHz

Figure 4 Sensor performance in both time and frequency domain

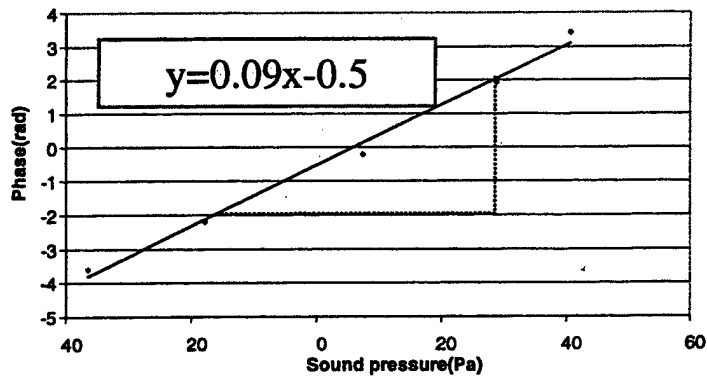

Figure 5 Calibration for the system sensitivity