



Carnegie Mellon
Software Engineering Institute

Predictable Assembly of Substation Automation Systems: An Experiment Report

Scott Hissam
John Hudak
James Ivers
Mark Klein
Magnus Larsson
Gabriel Moreno
Linda Northrop
Daniel Plakosh
Judith Stafford
Kurt Wallnau (corresponding author)
William Wood

DISTRIBUTION STATEMENT A
Approved for Public Release
Distribution Unlimited

September 2002

TECHNICAL REPORT
CMU/SEI-2002-TR-031
ESC-TR-2002-031

20030321 026

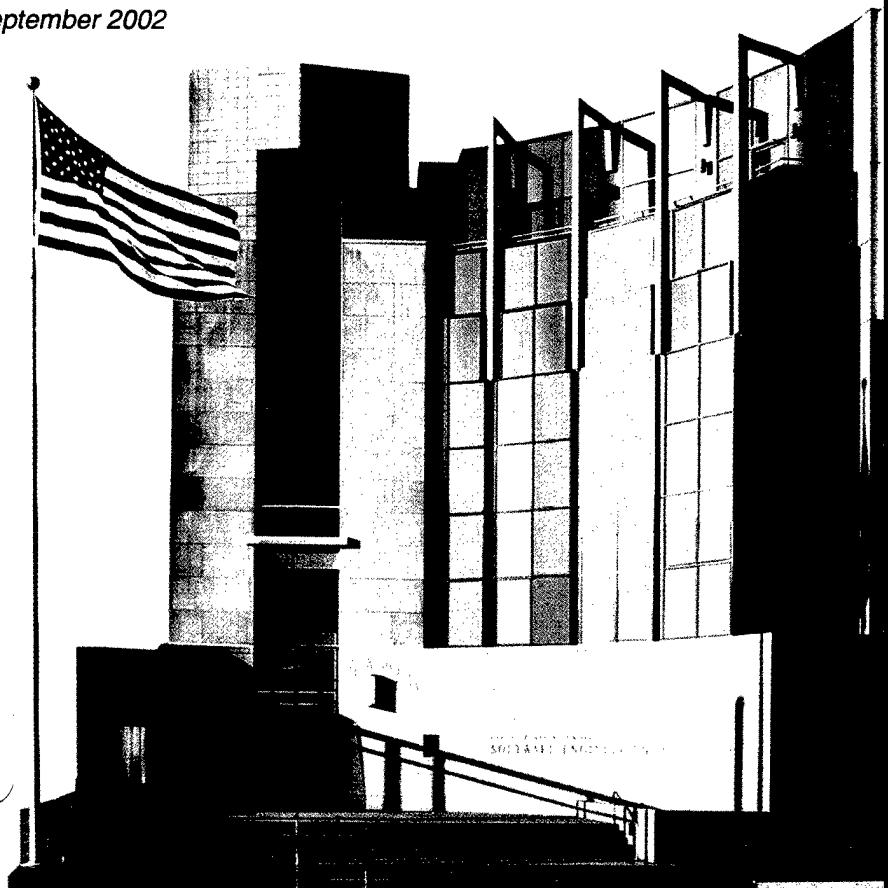

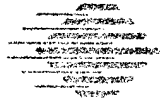

**Carnegie Mellon
Software Engineering Institute**

Pittsburgh, PA 15213-3890

Predictable Assembly of Substation Automation Systems: An Experiment Report

CMU/SEI-2002-TR-031
ESC-TR-2002-031

Scott Hissam
John Hudak
James Ivers
Mark Klein
Magnus Larsson
Gabriel Moreno
Linda Northrop
Daniel Plakosh
Judith Stafford
Kurt Wallnau (corresponding author)
William Wood

September 2002

**Predictable Assembly from Certifiable Components
Initiative**

Unlimited distribution subject to the copyright.

This report was prepared for the

SEI Joint Program Office
HQ ESC/DIB
5 Eglin Street
Hanscom AFB, MA 01731-2116

The ideas and findings in this report should not be construed as an official DoD position. It is published in the interest of scientific and technical information exchange.

FOR THE COMMANDER



Christos Scondras
Chief of Programs, XPK

This work is sponsored by the U.S. Department of Defense. The Software Engineering Institute is a federally funded research and development center sponsored by the U.S. Department of Defense.

Copyright 2002 by Carnegie Mellon University.

Requests for permission to reproduce this document or to prepare derivative works of this document should be addressed to the SEI Licensing Agent.

NO WARRANTY

THIS CARNEGIE MELLON UNIVERSITY AND SOFTWARE ENGINEERING INSTITUTE MATERIAL IS FURNISHED ON AN "AS-IS" BASIS. CARNEGIE MELLON UNIVERSITY MAKES NO WARRANTIES OF ANY KIND, EITHER EXPRESSED OR IMPLIED, AS TO ANY MATTER INCLUDING, BUT NOT LIMITED TO, WARRANTY OF FITNESS FOR PURPOSE OR MERCHANTABILITY, EXCLUSIVITY, OR RESULTS OBTAINED FROM USE OF THE MATERIAL. CARNEGIE MELLON UNIVERSITY DOES NOT MAKE ANY WARRANTY OF ANY KIND WITH RESPECT TO FREEDOM FROM PATENT, TRADEMARK, OR COPYRIGHT INFRINGEMENT.

This work was created in the performance of Federal Government Contract Number F19628-00-C-0003 with Carnegie Mellon University for the operation of the Software Engineering Institute, a federally funded research and development center. The Government of the United States has a royalty-free government-purpose license to use, duplicate, or disclose the work, in whole or in part and in any manner, and to have or permit others to do so, for government purposes pursuant to the copyright license under the clause at 252.227-7013.

Use of any trademarks in this report is not intended in any way to infringe on the rights of the trademark holder.

For information about purchasing paper copies of SEI reports, please visit the publications portion of our Web site (<http://www.sei.cmu.edu/publications/pubweb.html>).

Table of Contents

Acknowledgements	xi
Executive Summary	xiii
Abstract	xvii
1 Introduction	1
1.1 Background	2
1.2 Approach	2
1.3 Objective of This Report	2
1.4 Audience for This Report	3
1.5 Structure of This Report	3
2 Model Problems for Substation Automation	5
2.1 Three Model Problems and Three PECTs	5
2.2 The IEC 61850 Domain Model	7
2.3 Lab Environment and the SEI Switch	9
3 Prediction-Enabled Component Technology	11
3.1 The Theory of PECT	11
3.2 The Structure of PECT	12
3.2.1 Component Technology	13
3.2.2 Prediction Enablers	14
3.2.3 PECT=Component Technology+Analysis Technology	14
3.3 The Pin Style	14
3.3.1 Components and Pins	15
3.3.2 Assemblies and Environments	17
3.3.3 Behavior: Reaction and Interaction	19
3.3.4 Hierarchical Assembly	21
3.4 Pin Subset in SAS Model Solutions	21
3.5 SAS Software Controller in Pin	22

4	PECT Process and Workflows	25
4.1	The PECT Development Process	25
4.1.1	Deliverables	26
4.1.2	Workers, Activities, and Artifacts	27
4.2	Workflows	29
4.2.1	Definition Phase	29
4.2.2	Co-Refinement Phase	30
4.2.3	Validation Phase	31
4.2.4	Packaging Phase	33
5	Co-Refinement of the Controller PECT	35
5.1	What Is Co-Refinement?	35
5.2	How Co-Refinement Proceeds	35
5.3	Key Ideas for the Controller PECT	37
5.4	Co-Refinement of the Controller PECT	37
5.4.1	Initial Conditions	37
5.4.2	First Iteration: Worst-Case Latency (λ_W)	38
5.4.3	Second Iteration: Average Latency (λ_A)	40
5.4.4	Third Iteration: Worst-Case Latency + Blocking (λ_{WB})	41
5.4.5	Fourth Iteration: Average Latency + Blocking (λ_{AB})	41
5.4.6	Fifth Iteration: Asynchronous Interactions (λ_{ABA})	42
6	Empirical Validation	43
6.1	What Is Empirical Validation?	43
6.2	Introduction to Statistical Labels	43
6.2.1	Component Labels	44
6.2.2	Property Theory Labels	45
6.3	Workflow for Empirical Validation	47
6.3.1	Define Validation Goal	47
6.3.2	Define Measures	48
6.3.3	Define Sampling Procedure	49
6.3.4	Develop Measurement Infrastructure	50
6.3.5	Collect Validation Data	51
6.3.6	Analyze Results	51
7	Safety and Liveness Analysis in the Controller PECT	53
7.1	Model Checking	53
7.2	Process	54
7.3	Building the Model	55
7.3.1	Determining the Scope of Problem Analysis	55
7.3.2	Producing a Pin Model of the Problem	56
7.3.3	Translating the Pin Model into a State Machine	57

7.3.4	Translating the State Machine into NuSMV	59
7.4	Analyzing the Model	60
7.4.1	Types of System Properties	60
7.4.2	Temporal Logic	61
7.4.3	CSWI Claims	62
8	Discussion	65
8.1	Results on Method	65
8.1.1	Interfaces Between Specialized Skills	65
8.1.2	Infrastructure Complexity	67
8.1.3	Design Space: Rules for Inclusion <i>and</i> Exclusion	68
8.1.4	Confidence Intervals for Formal Theories	69
8.2	Results on Model Solutions	70
9	Next Steps	73
9.1	PECT Infrastructure	73
9.1.1	Measurement and Validation Environment	73
9.1.2	Core Pin Language and Assembly Environment	74
9.1.3	Real-Time Component Runtime Environment	74
9.1.4	Model Checking (Analysis) Environments	75
9.2	PECT Method	75
9.2.1	PECT Empirical Validation Guide	76
9.2.2	Certification Locale and Foundations for Trust	76
Appendix A	λ_{ABA} Property Theory	77
A.1	Essential λ_{ABA} Concepts	77
A.2	λ_{ABA} Simulator	79
A.3	Pin- λ_{ABA} Interpretation (Discussion)	82
A.4	Pin- λ_{ABA} Interpretation (Formal)	89
Appendix B	λ_{ABA} Empirical Validation	93
B.1	Introduction	93
B.2	Empirical Validation	93
B.3	Conclusions	123
B.4	StInt Program	123
Appendix C	NuSMV Model of CSWI	125
Appendix D	Switch Schematic	127
Acronym List	133

Bibliography 135

List of Figures

Figure 1: Three PECTs.....	6
Figure 2: Key Concepts of the IEC 61850 Standard for a SAS Model Problem... ..	8
Figure 3: SEI Switch Abstraction	9
Figure 4: Interpretations on Constructive Assemblies and Analysis Views	12
Figure 5: The Four Environments of a PECT	13
Figure 6: Pin Notation.....	15
Figure 7: A Simple Assembly	18
Figure 8: Reactions Specify Component Behavior.....	20
Figure 9: SAS Software Controller in Pin	23
Figure 10: An Overview of the PECT Development Method	26
Figure 11: Definition Phase Workflow.....	29
Figure 12: Co-Refinement Workflow.....	30
Figure 13: Empirical Validation Workflow	32
Figure 14: Clock Component Initiating a Sequence of Interactions	39
Figure 15: Expanded Workflow for Empirical Validation.....	47
Figure 16: Controller System Diagram	56
Figure 17: CSWI Pin Specification	57
Figure 18: CSWI State Machine	58
Figure 19: NuSMV Counterexample.....	63
Figure 20: Interfaces Among PECT Development Skills	66
Figure 21: Results of Spot Validation of Operator PECT Latency Theory	71

Figure 22: Task Phasing and Hyper-Period	78
Figure 23: Elements of the λ_{ABA} Analytic Model	79
Figure 24: Blocking Example	79
Figure 25: Prediction Pseudocode	81
Figure 26: Initialize Pseudocode	81
Figure 27: ExecuteTask Pseudocode.	82
Figure 28: getJobLatencies Pseudocode	82
Figure 29: Simple Constructive Assembly	83
Figure 30: Timeline for a Sink Pin with Interactions in the Middle of Its Execution.	83
Figure 31: Timeline for a Sink Pin with Interactions at the End of Its Execution . .	84
Figure 32: Constructive Assembly with Tree-Like Topology	85
Figure 33: Constructive Assembly with Asynchronous Connections	86
Figure 34: Mixed Synchronous and Asynchronous Connections.	87
Figure 35: Multiple Asynchronous Connections Problem.	89
Figure 36: Multiple Asynchronous Connections Rewrite	89
Figure 37: Pin Component Enter and Leave Events	94
Figure 38: Time Measurements on Component Sink and Source Reactions.	95
Figure 39: Measuring the Execution Time of a Pin Component.	95
Figure 40: A Simple Linear Interaction	96
Figure 41: A Simple Multilinear Interaction.	96
Figure 42: A Simple One-to-Many Interaction	96
Figure 43: A Simple Many-to-One Interaction	97
Figure 44: A Simple Many-to-Many Interaction	97
Figure 45: Measuring the Latency for a Simple Assembly	97

Figure 46: Execution Calculation Made by the Synthetic Component	98
Figure 47: General Assembly Topology Description for Benchmarking Synthetic	100
Figure 48: General Assembly Topology for Benchmarking Synthetic	100
Figure 49: Example Measures for Component Execution Time	101
Figure 50: Variation Points for One Assembly Design Space	103
Figure 51: Example of a Randomly Selected Assembly.	104
Figure 52: Topology of an Example of a Randomly Selected Assembly	105
Figure 53: Measurement Infrastructure Tool Workflow.	107
Figure 54: Histogram of AVGMRE Job.	118
Figure 55: Histogram of LOG(AVGMRE) Job.	118
Figure 56: Distribution-Free Calculation Using StInt.	119
Figure 57: Summary of the AVGMRE Job Grouped by MRE.	121
Figure 58: SEI Switch: Full Schematic	127
Figure 59: SEI Switch: Upper Right Quadrant	128
Figure 60: SEI Switch: Lower Right Quadrant	129
Figure 61: SEI Switch: Upper Left Quadrant	130
Figure 62: SEI Switch: Lower Left Quadrant	131

List of Tables

Table 1:	IEC 61850 LNs as Components of the Controller PECT.....	8
Table 2:	PECT Development Activities	27
Table 3:	Distribution-Free Tolerance Interval for λ_{ABA}	46
Table 4:	(Optimistic) Distribution-Free Tolerance Interval for λ_{ABA}	51
Table 5:	Areas of Expertise Needed to Build SAS Operator and Controller PECTs.....	65
Table 6:	Merge Operation Example.....	87
Table 7:	Combine Operation Example	88
Table 8:	Syntax-Directed Definition for the Analytic Interpretation	91
Table 9:	Variation Points for All Assembly Design Spaces	103
Table 10:	Predicted Latency for Synthetic5's Job	105
Table 11:	Observed Average Latency for an Assembly	106
Table 12:	Measurement Infrastructure Tool Suite.....	107
Table 13:	Hardware Characteristics	111
Table 14:	Software Characteristics	111
Table 15:	Processes (Running Tasks)	112
Table 16:	Recorded Actual Execution Time Per Synthetic Pin Component ...	112
Table 17:	Recorded Predicted and Actual Latencies Per Job.....	113
Table 18:	Descriptive Statistics for Job Assembly Measurements	116
Table 19:	Results from the Shapiro-Wilk Normality Test on AVGMRE.....	117
Table 20:	Results from the Shapiro-Wilk Normality Test on LOG(AVGMRE)..	117
Table 21:	Results from the Initial Calculation for a One-Sided Distribution-Free Tolerance Interval	120

Table 22: Descriptive Statistics for Hypothesis Data Sets	121
Table 23: Hypothesis Calculations for a One-Sided, Distribution-Free Tolerance Interval.	122
Table 24: Final Statistical Labels for All Hypotheses	122

Acknowledgements

The authors would like to thank Otto Preiss and Holger Hoffman from Asea Brown Boveri, Ltd. (ABB) for providing invaluable expertise on substation automation. We also wish to thank Ivica Crnkovic and Mälardalen University for their continuing support of our work in predictable assembly.

Executive Summary

Background

The Predictable Assembly from Certifiable Components (PACC) Initiative at the Software Engineering Institute (SEISM) is developing methods and technologies for predictable assembly. A software development activity that builds systems from components is *predictable* if the runtime behavior of an assembly of components can be predicted from known properties of components and their patterns of interactions (connections), and if these predictions can be *objectively validated*. A component is *certifiable* if these known properties can be obtained or validated by independent third parties.

The SEI's approach to predictable assembly² is through prediction-enabled component technology (PECT). At the highest level, PECT is a scheme for systematic and repeatable integration of software component technology, software architecture technology, and design analysis and verification technology. This scheme is not simply technological; it also includes the processes needed to design and validate the predictive powers of a PECT. A PECT, then, is a *packaging* of engineering methods and a supporting technical infrastructure that, together, enable predictable assembly from certifiable components.

PACC became an SEI initiative on October 1, 2002. Prior to that, from 1999-2001, PACC was considered an exploratory research project. The objective of such a project at the SEI is to develop an understanding of a problem area and proposed solutions for it. During the third year of exploratory research (2001-2002) the SEI, in partnership with an industrial sponsor, the Asea Brown Boveri, Ltd. Corporate Research Center (ABB/CRC), undertook the prototyping effort described in this report.

Objective

The objective of this prototyping effort was not to develop a PECT solution for a particular design problem per se, but rather to explore as many aspects of PECT as is practical within a limited time frame. Our primary concerns were methodological and practical: Could we define a process for developing, and validating PECTs? Would the process be practical? What are the risks to transitioning PECT to practice? What are the technical limits of PECT, and how might

1. SEI is a service mark of Carnegie Mellon University.

2. In this report, the term *predictable assembly* means *predictable assembly from certifiable components*.

they be overcome? On more than one occasion, our prototyping effort was diverted to explore these and similar questions.

Approach

To focus and ground our research, we selected as a prototype problem the substation automation system (SAS), an application area in the domain of power generation, transmission, and management. This problem area was chosen because it is well bounded, well defined, and representative of the broader class of critical infrastructure systems. The SEI defined three model problems in the predictable assembly of SAS: the assembly of an operator station, a primary equipment controller, and an integrated operator/controller. The nominal objective of the prototype was to develop three PECTs, one for each model problem.

Results of This Work

This report describes the results of an experimental application of PECT to SAS, focusing on the primary equipment PECT, the SAS switch controller. A low-power, high-speed switch was developed by the SEI to simulate primary equipment. Controller assemblies were developed in accordance with the International Electrotechnical Commission (IEC) 61850 standard for substation controllers, and laboratory scenarios were developed for external switch control and over-current protection. A family of latency models and their interpretations (λ_*) were developed to predict point-to-point, intra-assembly (intra-controller) latency. One member of this family, average case latency with blocking and asynchrony (λ_{ABA}), was empirically validated.

Primary results. The primary results of this work were methodological. We developed an overall process model for the design, development, and validation of PECTs. We studied two key processes in depth: *co-refinement* and *empirical validation*. Technically, *co-refinement* is the process of defining an interpretation from component model to analysis model. Intuitively, it is a negotiation that results in a component model that is expressive enough to span an intended application area, but restrictive enough to ensure that analysis is tractable. Technically, *empirical validation* defines measurement procedures for obtaining component measures and assembly measures, and for designing the experiments to compare the predicted and observed assembly measures. Intuitively, it is a means of attaching meaningful statistical labels to components and the predictive powers of PECT analysis.

Secondary results. The secondary results of this work were technological. We developed a measurement and validation infrastructure and gained valuable experience in the construction of a laboratory environment for empirical validation. More significantly, we specified an *analytically extensible* component model. This model defines the basics of component interface and connection topology (assembly) and is extended by formal interpretations to one or more analysis models. An analysis model supports compositional reasoning about assembly properties P_A and defines the component properties P_C required to predict P_A . Each interpretation

may impose additional constraints on components and their topologies. In return, each analysis model guarantees that assemblies of components satisfying these constraints will be analyzable, and hence be *predictable by construction*, with respect to P_A .

Although the work emphasized empirical predictability, *formal* approaches to predictability were also explored. Specifically, safety conditions for the prototype (hardware) switch and IEC 61850 (software) controller dealing with the over-current protection components were expressed in branching time temporal logic. State machines for these components were developed, and the safety and liveness conditions were verified using the SMV model checker.³

Tertiary results. The tertiary results of this work were the PECTs themselves. A PECT was developed for the operator interface and controller. The operator PECT was developed on the Microsoft .NET environment. Latency predictions for operator interfaces were accurate (< 3% magnitude of relative error [MRE]) but not technically demanding. More interesting was the controller PECT, which was substantially more complex and demanding. Controller assemblies introduced threading, contention, priority-based scheduling, and periodicity not encountered in the operator PECT. The original normative requirement for controller latency prediction was a 90% confidence interval that 80% of predictions would not exceed an upper bound 5% MRE. This norm was arbitrary and served primarily as a plot device. Still, λ_{ABA} predictions came within a whisker of satisfying that norm despite the use of a non-real-time, non-optimized operating system, Microsoft Windows 2000: we achieved a >99% confidence interval that 80% of predictions will fall within an upper bound of 10% MRE. Moreover, under the assumption that identified systematic error can be eliminated (reasonable, given the stability of the error), these results will improve to a >99% confidence interval that 80% of predictions will fall within an upper bound of 4% MRE.

Next Steps

The results of the exploratory prototype are encouraging. However, as expected, there are aspects of PECT that require further elaboration, and some that have yet to be explored. This report identifies two areas requiring attention.

First, a technology infrastructure for specifying and deploying components and their assemblies must be constructed; the substation automation prototypes relied on manual processes for much of this. We developed a substantial suite of tools to support empirical validation, but greater automation is still required to generate the massive data sets required to adequately validate even moderately complex analysis models.

3. SMV is a symbolic model-checking tool developed at Carnegie Mellon University. For more information about it, see <<http://www.cs.cmu.edu/~modelcheck/smv/smvmanual.ps>>.

Second, the methods and technologies needed to support independent (third-party) measurement and certification of components and PECTs must be established; the substation automation prototypes relied on *in situ* measurements. Means must be established for acquiring measurements in third-party environments, establishing and maintaining trust in assertions about those measurements, and extrapolating those assertions to different, possibly heterogeneous development and deployment environments.

Abstract

The Predictable Assembly from Certifiable Components (PACC) Initiative at the Software Engineering Institute (SEISM) is developing methods and technologies for predictable assembly. A software development activity that builds systems from components is *predictable* if the runtime behavior of an assembly of components can be predicted from known properties of components and their patterns of interactions (connections), and if these predictions can be *objectively validated*. A component is *certifiable* if these known properties can be obtained or validated by independent third parties. The SEI's technical approach to PACC rests on prediction-enabled component technology (PECT). At the highest level, PECT is a scheme for systematic and repeatable integration of software component technology, software architecture technology, and design analysis and verification technology. This report describes the results of an *exploratory* PECT prototype for substation automation, an application area in the domain of power generation, transmission, and management. This report focuses primarily on the methodological aspects of PECT; the prototype itself was only a means to expose and illustrate the PECT method.

4. SEI is a service mark of Carnegie Mellon University.

1 Introduction

The Predictable Assembly from Certifiable Components (PACC)⁵ Initiative at the Software Engineering Institute (SEISM) is developing methods and technologies for predictable assembly. A software development activity that builds systems from components is *predictable* if the runtime behavior of an assembly of components can be predicted from known properties of components and their patterns of interactions (connections), and if these predictions can be *objectively validated*. A component is *certifiable* if these known properties can be obtained or validated by independent third parties.

The SEI is not alone in pursuing the objectives of PACC, although academic and commercial terminology may obscure this fact for those not deeply familiar with the subject. The SEI technical approach to PACC rests on prediction-enabled component technology (PECT). At the highest level, PECT is a scheme for systematic and repeatable integration of software component technology, software architecture technology, and design analysis and verification technology. The results of this integration are engineering methods and a supporting technical infrastructure that, together, enable *predictable assembly from certifiable components*.⁷

This report describes an *exploratory* prototype of PECT. We emphasize the word *exploratory*, since the objective of the work was to touch on as many methodological and technological aspects of PECT as possible, using the broad constraints imposed by an industrially significant problem area as a guide. We selected the problem area of substation automation, an application area in the domain of power generation, transmission, and management, because it is well bounded, well defined, and representative of the broader class of critical infrastructure systems.

5. For more information on this initiative, see <<http://www.sei.cmu.edu/pacc>>.

6. SEI is a service mark of Carnegie Mellon University.

7. We will henceforth use the term *predictable assembly* to mean *predictable assembly from certifiable components*.

1.1 Background

In 2000, the SEI initiated a feasibility study in predictable assembly. The study was undertaken to

- identify the fundamental science and engineering challenges posed by predictable assembly and software component certification
- determine if the need to address these challenges was widespread and of economic or strategic interest to the U.S. Department of Defense (DoD) and to the software industry as a whole
- ascertain whether technological and methodological elements to address these challenges existed, or could be created with reasonable probability and effort

In 2001, the SEI formed a collaboration with the Asea Brown Boveri, Ltd. Corporate Research Center (ABB/CRC). This collaboration was established to undertake a two-year feasibility study of predictable assembly in an industrial setting. The application area was in power generation and transmission systems, specifically, *substation automation systems* (SASs). Typically, an SAS is implemented as a distributed system composed of 20 to 100 computing elements (personal computers and/or other electronic computing devices) executing a mix of soft- and hard-real-time applications. An SAS is characterized by stringent performance and reliability requirements.

1.2 Approach

The SEI/ABB joint feasibility study intended to address two broad feasibility questions:

1. Can a practical technology infrastructure be developed to automate significant aspects of predictable assembly?
2. Can an engineering method be developed as a basis for the systematic improvement of an industry-wide capability in predictable assembly?

To conduct this feasibility exploration, the SEI and ABB defined a series of model problems. Briefly, a model problem is a simplification of a more complex one such that a solution to it can be extrapolated to that of a real problem. In 2001 and 2002, three model SAS problems were specified; in 2002 and 2003, they will be extended to include the domain of industrial robotics.

1.3 Objective of This Report

This report consolidates the results and discoveries of the first year of the SEI/ABB investigation in predictable assembly. It is, in effect, a retrospective on an extended laboratory experi-

ment. Our intent is that this report serve as a basis for continued research within the SEI's PACC Initiative. Our intent is also that this report, when combined with related SEI publications on predictable assembly and PECT, will provide a valuable resource for other applied research in this field.

1.4 Audience for This Report

The audience for this report is computer scientists and software engineering researchers with an interest in predictable assembly from certifiable components (by any other name). We assume that readers have technical backgrounds that are both diverse and deep, spanning areas of software architecture, software component technology, probability and measurement theory, real-time systems, and model checking, to name the major areas reflected in this report. Therefore, this report is not meant to serve as a general introduction to predictable assembly, component technology, or PECT.

1.5 Structure of This Report

An overview of substation automation and the details of the SAS model problems are described in Chapter 2. In Chapter 3, we provide an overview of the technical concepts of PECT. The key workflows of a process for developing and validating a PECT are summarized in Chapter 4. In Chapter 5, we summarize the chronology of a key development activity in the design of a PECT, called co-refinement, the result of which was a controller PECT for predicting point-to-point latency for any controller assembly. The techniques used to empirically validate the SAS-controller PECT are outlined in Chapter 6. In Chapter 7, the focus shifts from empirical to formal approaches to predictable assembly, where we describe the use of model checking to verify safety and liveness conditions of controller assemblies using temporal logic. Chapter 8 extracts the key results of the work to date, emphasizing the benefits and risks of the PECT approach to predictable assembly. The plan for the next phase of our investigation is outlined in Chapter 9.

More details on the work are provided in appendices of this report. Appendix A describes the λ_{ABA} analysis model for predicting controller latency and its interpretation; this is the model that emerged from co-refinement. A detailed account of the empirical validation of λ_{ABA} is provided in Appendix B. In Appendix C, we provide the temporal-logic specifications and state model used to reason about controller safety conditions. Appendix D provides a schematic for the switch hardware developed for the prototype. The Acronym List on page 133 defines the acronyms used in this report.

2 Model Problems for Substation Automation

The following description of an SAS is excerpted from a paper by Preiss and Wegmann [Preiss 01]:

Networks (power grids) of different topologies are responsible to transport energy over short or long distances and finally distribute it to end-consumers (such as households and companies). The nodes in such a network are called substations ... Substations may be manned or unmanned depending on the importance of the station and also on its degree of automation. Substations are controlled by Substation Automation Systems (SAS). Since unplanned network outages can be disastrous, an SAS is composed of all the electronic equipment that is needed to continuously control, monitor, and protect the network. This covers all the high voltage equipment outside the substation (overhead lines, cables, etc.) as well as those inside the substation (transformers, circuit breakers, etc.).

This combination of challenging and concrete requirements means that an SAS provides a good basis for model problems in predictable assembly. We outline the basic structure of the SAS model problems in Section 2.1. Background information on the International Electrotechnical Commission (IEC) 61850 standard, the SAS domain model used to develop the controller PECT prototype, is provided in Section 2.2. An overview of the hardware and software used in the operation and controller prototypes is provided in Section 2.3.

2.1 Three Model Problems and Three PECTs

The scale of an SAS depends on the cost, size, and criticality of the primary equipment that it manages. For the model problems described in this report, we envisage a manned SAS that has an operator workstation and one or more controllers, each of which controls some primary equipment, for example, breakers, switches, and transformers. The operator has a graphical display console for observing and interacting with primary equipment. For the purpose of this report, we are not concerned with details such as the allocation of controllers to bays or the interaction of multiple controllers (e.g., bay interlocking). Instead, we assume a single operator console, a single primary switch, and a single controller for that switch. From this general structure, we defined three model problems, each leading to a PECT as its model solution.

- 1 The overall scheme is depicted in Figure 1. The SEI developed a low-power, high-speed switch (labeled “SEI Switch” in Figure 1) to play the role of primary equipment. One model problem was to develop a PECT for predictably assembling SEI switch controllers, a second model problem was to develop a PECT for predictably assembling operator interfaces, and a third model problem was to develop a higher order PECT for composing controller and operator assemblies into an overall SAS application. This PECT would allow operators to monitor and control the state of the switch.

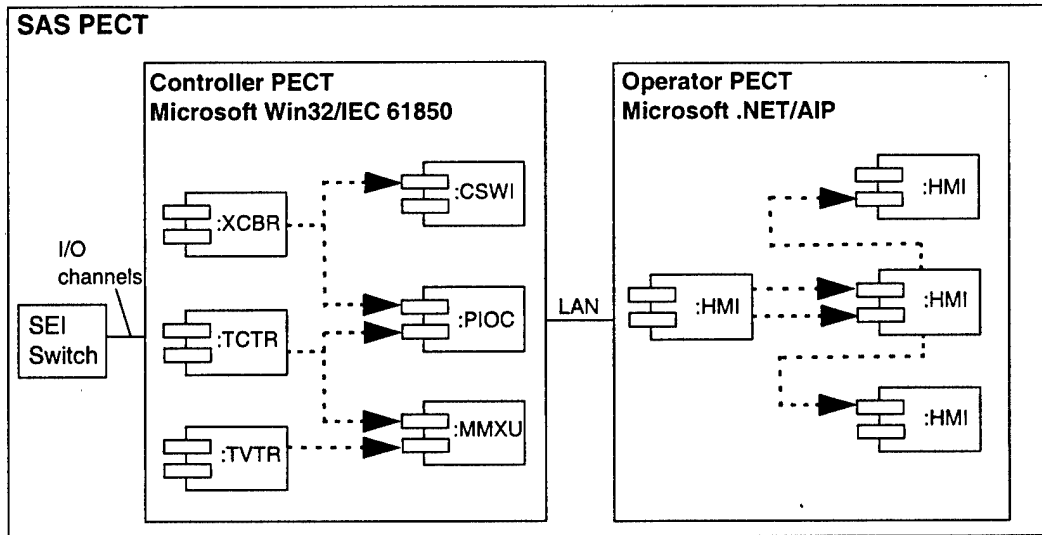

Figure 1: Three PECTs

The PECTs intended to enable the prediction of the end-to-end latency of operations within an operator assembly, within a controller assembly, and over a combined operator/controller assembly. Nominal requirements were established for the accuracy and reliability of predictions and were expressed as statistical tolerance intervals:⁸

- controller PECT: 99% confidence that 80% of latency predictions will have a magnitude of relative error (MRE) < 5%
- operator PECT: 95% confidence that 80% of latency predictions will have MRE < 10%
- SAS PECT: 95% confidence that 80% of latency predictions will have MRE < 10%

It must be emphasized that these requirements were not selected with any consideration for the practicality of or resemblance to operational requirements. For example, the controller PECT was to be developed on Windows 2000, and we understood that it is problematic to achieve the stated tolerance interval on that platform (given that Windows 2000 is not a real-time operating system). Instead, the above norms were selected as a plot device for our study of empirical validation.

8. The statistical intervals selected for these model problems were derived from Preiss and Wegmann's work [Preiss 01].

Although the model problems were purposely kept quite abstract, two technology decisions were made in the interest of reducing the gap between the model solutions and their ultimate deployment environments. The operator PECT was developed for the ABB Aspect Integration Platform (AIP). The AIP is a development and deployment environment for automation systems; it uses OPC⁹ to enable operator interfaces to communicate with controllers. The controller PECT was developed using the IEC 61850 standard for substation automation.

This report focuses on the controller PECT, since that model problem posed the most challenges. Although the latency prediction enabled by the controller PECT is quite flexible in defining the end points of an “end-to-end” latency prediction, two specific controller scenarios were defined:

1. switch control latency. In this scenario, we are interested in predicting the end-to-end latency of an operation to manually “throw” the SEI switch.
2. over-current protection latency. In this scenario, we are interested in predicting the time required to detect an over-current condition and automatically “throw” the switch.

These scenarios were selected in part because they correspond to actual SAS functionality, as defined in IEC 61850.

2.2 The IEC 61850 Domain Model

The IEC 61850 standard defines a domain model of the functionality of substation automation in a form that is readily adopted for use with software component technology [Ivers 02]. Figure 2 depicts, in the Unified Modeling Language (UML), the IEC 61850 concepts that are most important for SAS model problems. An SAS consists of a physical system and a logical system. The physical system comprises primary equipment, such as switches, breakers, and transformers, and secondary equipment, such as intelligent electronic devices (IEDs) or other controller hardware. The logical system comprises the data and software functions for Supervisory Control and Data Acquisition (SCADA), Energy Management Systems (EMSs), and other substation applications.

The IEC 61850 standard defines a variety of functions and the quality attributes required for each, including reliability, accuracy, and latency. Each function is defined in terms of one or more logical nodes (LNs). The standard defines many LNs; each one is a primitive building block from which many SAS functions may be composed. Conceptually, then, there is a close correspondence between LNs and software components. Although it is possible, and perhaps reasonable, to deploy several LNs as a single component, we chose to maintain a one-to-one correspondence between LNs and the software components that implement them.

9. OPC stands for OLE (Object Linking and Embedding) for Process Control.

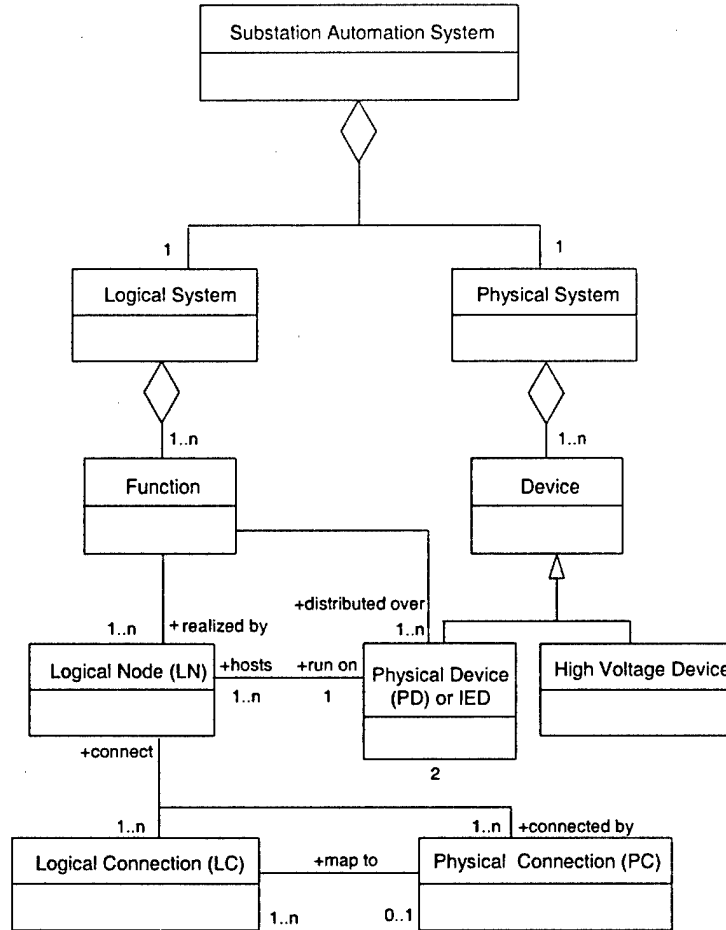

Figure 2: Key Concepts of the IEC 61850 Standard for a SAS Model Problem

The IEC 61850 components implemented for the controller PECT are summarized in Table 1. Only rudimentary functionality was implemented. (Other components that were developed but are not shown here include an OPC gateway for communicating with the operator PECT and a clock component for delivering periodic stimulus to controller components.)

Table 1: IEC 61850 LNs as Components of the Controller PECT

IEC 61850 LN	Summary of Function
TCTR	Calculates current
TVTR	Calculates voltage
MMXU	Calculates power
CSWI	Provides safety rules for the controller (e.g., select before use)
XCBR	Acts as the controller interface
PIOC	Provides over-current protection

2.3 Lab Environment and the SEI Switch

The hardware and software platforms used for the operator and controller PECTs were conventional, Intel-based personal computers running Microsoft's Windows 2000 operating system. The operator PECT was developed for Microsoft .NET in C#. The controller PECT used VenturCom's RTX¹⁰ real-time extensions package to support priority-based scheduling. Other details of the hardware and software configuration for the controller PECT are described in Table 13 and Table 14 on page 111.

The SEI also developed a low-power, high-speed switch to facilitate the prototype development. An abstraction of this switch is depicted in Figure 3; the actual schematic is shown in Figure 58 on page 127.

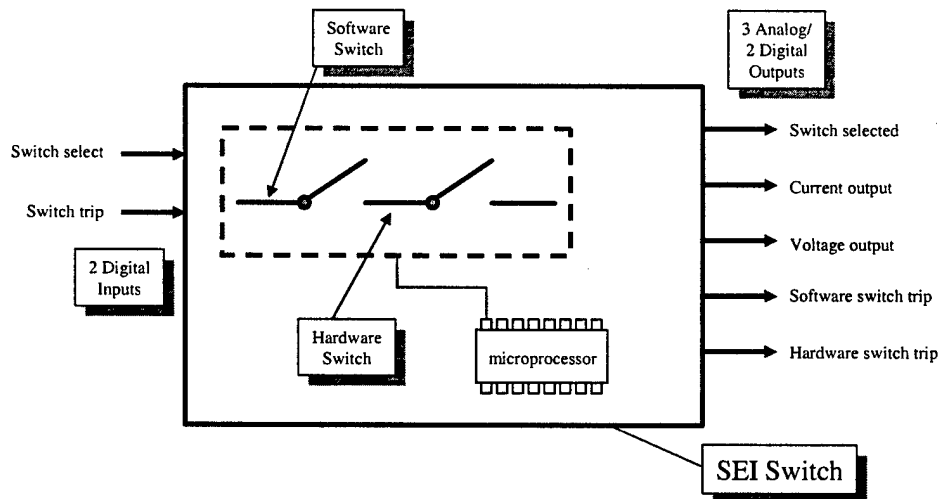

Figure 3: SEI Switch Abstraction

The SEI switch communicates with the software controller using two digital input channels for commands and five output channels (two digital and three analog) for status and values. Digital input is provided for the controller to select the switch and set its position to “open” or “close.” Analog output provides positive feedback on switch selection status and reports on the switch’s current, voltage, and position. The switch is implemented as a serial composition of two high-speed electronic switches, which are also known as TRIACs. One TRIAC represents the primary equipment being controlled (labeled “Software Switch” in Figure 3); the other is controlled internally on the SEI switch and used for over-current protection test scenarios (labeled “Hardware Switch” in Figure 3). The hardware switch is controlled by a microprocessor that monitors current and time. If the current exceeds a value for a specified duration (both are configurable), the microprocessor “throws” the hardware switch, representing a failure of the PIOC (see Table 1) component to protect the primary equipment.

10. See <<http://www.vci.com>> for details about this software package.

The software switch is operated by a software controller running on the Windows 2000 platform through a data acquisition card that is connected to the analog and digital lines. This controller is shown in detail in Figure 9 on page 23.

3 Prediction-Enabled Component Technology

Our approach to predictable assembly is to develop and use *prediction-enabled component technologies* (PECTs). We formulated the basic concepts of PECT prior to undertaking our SAS effort [Hissam 02], but refined and expanded them substantially as a result of the work reported here.

In this chapter, we first outline the theory of PECT in Section 3.1 and then describe the structure of a PECT implementation in Section 3.2. Next, we provide an overview of *Pin*, the core component model we use to build PECTs, in Section 3.3. Not all the *Pin* features described in this report were implemented in the model solutions; those that were are summarized in Section 3.4.

In the following discussion, we adopt the terminology of architecture documentation used by Clements and associates to describe PECT [Clements 02b]. You should consult their work if the meanings of these terms are not self evident. Our only modification to this terminology is that, in some situations, we prefer the term *assembly to view*¹¹ for its connotations of compositionality.

3.1 The Theory of PECT

Component composition, in the literature, almost universally assumes an underlying component-and-connector **viewtype**.¹¹ Correspondingly, a PECT has a central **component-and-connector**¹¹ viewtype, called the *constructive* viewtype that models runtime components and their interaction topologies. In general, we denote a view in this viewtype as a *constructive assembly*. The constructive viewtype has one or more analysis viewtypes, called *analysis views*,¹² associated with it. Each analysis viewtype provides a basis for compositional reasoning about some runtime behavior, for example, latency, security, safety, liveness, or reliability.

11. As defined by Clements and associates [Clements 02b].

12. In previous documents, we referred to analysis views as analysis assemblies. *View* seems preferable to *assembly* here, because *assembly* has a stronger connotation of components and connectors than can be justified in the general case of views that support behavioral analysis technology. However, in this case study, the term *analysis assembly* turns out to be appropriate.

In PECT, analysis views are derived automatically from constructive assemblies by means of a syntactic transformation, called an *interpretation* (see Figure 4). An interpretation is a partial function from constructive assemblies to analysis views. Three interpretations are shown in Figure 4: I_{LATENCY} , I_{SAFETY} , and I_{AVAIL} .

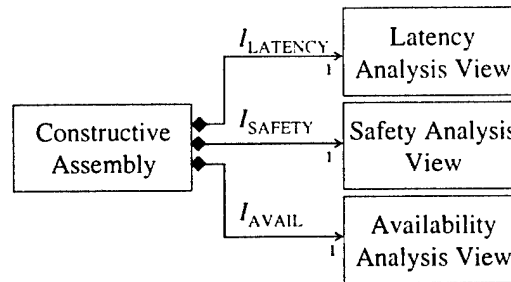

Figure 4: Interpretations on Constructive Assemblies and Analysis Views

Interpretations may impose constraints on constructive assemblies beyond those specified in the constructive viewtype, for example, restrictions on allowed topologies of component interactions or on component behavior. Interpretations may also require analysis-specific component information that is not defined in the constructive viewtype. For example, a latency analysis viewtype might require the priority assignment of component execution threads.

An interpretation is *consistent* if each constructive assembly is related to, at most, one analysis view under that interpretation. An interpretation is *valid* if there is empirical or formal justification for the claim that behaviors predicted in the analysis view will be manifested by the assembly of components specified in the constructive view. A PECT, then, consists (in part) of a set of consistent and valid interpretations.

3.2 The Structure of PECT

Figure 5 depicts the four different environments in PECT and their conceptual dependencies in terms of a UML class diagram. As implied by its name, a PECT consists of a *component technology* that has been extended with one or more *prediction-enabling technologies*. We do not claim to have discovered a universally acceptable definition of these technologies; instead, we define them relative to PECT. The assembly and runtime environments are provided by a *component technology* discussed in Section 3.2.1, while the analysis and validation environments are provided by a *prediction-enabling technology* discussed in Section 3.2.2.

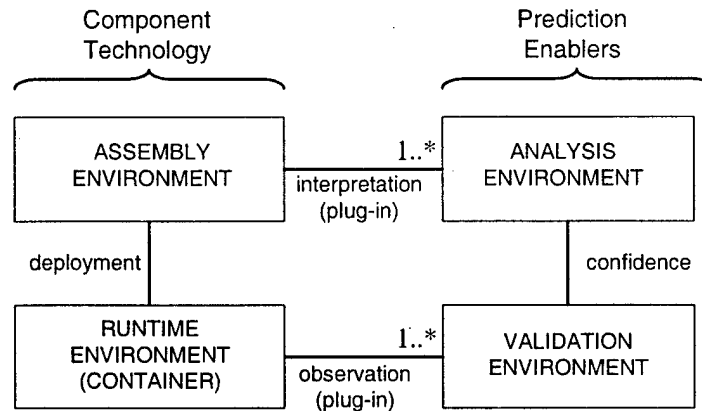

Figure 5: The Four Environments of a PECT

3.2.1 Component Technology

A component technology comprises an assembly environment and a runtime environment. In current literature and commercial products, a component runtime environment is often referred to as a *container*. We prefer our own terminology here.

- The assembly environment supports development-time activities such as selecting components, configuring component properties, and connecting components into assemblies. An assembly environment supports pure composition if those operations are the only ones required to develop applications. Pure composition involves developing applications entirely from components and connectors.
- The runtime environment manages the execution of components (e.g., their execution schedules and life cycles), manages resources shared by components, and provides services that allow components to interact with the external world.

Assemblies are deployed in their runtime environment, that is, by a mechanism either native or external to the component technology.

Not shown in Figure 5 is the fact that both of the above environments are specialized to support a particular *constructive model*.¹³ The constructive model specifies the types of components in an assembly, their type-specific runtime behavior, and the constraints on their connection topology [Bachmann 00]. In our view, this concept of constructive model is nearly (if not exactly) identical to that of *architectural style*, as that term has been used in current literature [Gardiner 00], [Bass 98], [Clements 02b]. Therefore, the *Pin constructive model*, or,

13. Our use of the term *constructive model* supersedes the earlier, and more ambiguous, term *component model*.

more ponderously, the *Pin constructive component model*, is also sometimes referred to as the *Pin style*. Pin is described in Section 3.3.

3.2.2 Prediction Enablers

Prediction enablers comprise an analysis environment and a validation environment:

- The *analysis environment* supports reasoning about the runtime behavior of a system. Simplistically, reasoning is *compositional* if it supports “divide-and conquer” analysis.
- The *validation environment* is an infrastructure for controlled, experimental validation of predictions of assembly behavior made in the analysis environment.

The association between the analysis and validation environments shown in Figure 5 reflects a logical dependency between the theoretical model underlying a particular form of design analysis and the experimental apparatus needed to experimentally validate the theory.

3.2.3 PECT=Component Technology+Analysis Technology

We enable reasoning in a component technology by extending its assembly environment with one or more analysis environments. This extension is implemented via a plug-in interface. An analysis environment provides an implementation that satisfies the plug-in, which, in turn, allows users of an assembly environment to reason about as many assembly properties as there are plug-ins.

We enable the validation of analysis technology by extending the component runtime with one or more validation environments. This extension is also implemented by means of a plug-in interface, although in this case, we do not envisage multiple validation environments operating concurrently (but you never know). The observation mechanism is based on execution traces where observable trace events (e.g., procedure calls or message exchanges) have been annotated with property-theory-specific information.

3.3 The Pin Style

Pin allows us to emphasize the compositional potential of software component technology. This may sound tautological at first, but, with a little study, it becomes apparent that components and composition do not always go hand in hand. Consider, for example, the amount of “glue” code that must often be developed, in conventional programming languages, to integrate components [Wallnau 02].¹⁴ With Pin, we can explore the potential for pure composition. It is our view that breakthroughs in programmer productivity and system quality require

14. By “glue” code, we mean something messy and ad hoc that integrators cobble together as needed. While connectors are also a form of “glue,” we typically think of connectors as being well defined and provided by a compiler or infrastructure.

higher level programming abstractions, and that pure composition has many of the qualities we might want such abstractions to possess, especially when it is “prediction enabled.”

The Pin style (hereafter referred to as simply *Pin*) adopts the hardware metaphor that components interact with their environment through a set of *pins*. Components in Pin are specified as a set of pins and pin behaviors; assemblies are specified as a set of connections among pins. Pin defines a number of *connectors*, each specialized to a particular type of pin and pin-to-pin interaction scheme. In this report, we provide a high-level overview of the graphical notation for Pin and the connectors used in SAS PECTs. A more formal and detailed treatment is provided by Ivers and associates [Ivers 02].

We describe the notation of components and pins in Section 3.3.1, assemblies and environments in Section 3.3.2, the behavioral specification of components and the composition of component behavior in Section 3.3.3, and assemblies of assemblies in Section 3.3.4.

3.3.1 Components and Pins

A component interacts with the external world exclusively through its *pins*; there are no other communication paths to or from a component. There are two types of pins: *sink* pins and *source* pins. A component receives communication (stimuli) *from* the environment via its sink pins and sends communication (responses) *to* the environment via its source pins. Figure 6 depicts the graphic notation we use. As suggested by the different shapes given to *pin heads* in Figure 6, there are different types of source and sink pins. These types and their notations are defined in the following sections.

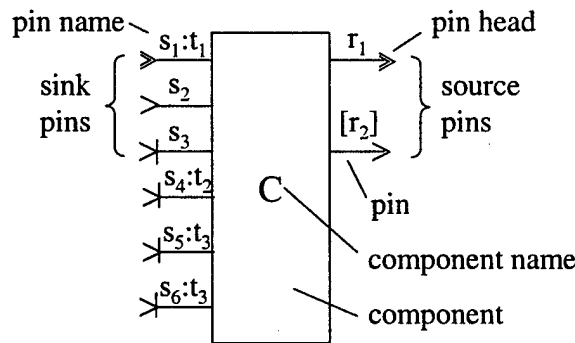

Figure 6: Pin Notation

Components are denoted by c_j , sink pins are denoted by s_j (for stimulus_j), and source pins are denoted by r_j (for response_j). Where the distinction between sink and source pin is irrelevant, we use p_j (for pin_j). In all cases, we omit subscripts where they are not required. Component names, which must be unique, are also used as pin names. The expression $c.p$ denotes pin p of component c . We use capitalized names to denote the predicates defined on pins. For example,

SomeCondition(c.p) is true if pin c.p satisfies SomeCondition, and is false otherwise. We use lowercase names to denote properties of pins. For example, someProperty(c.p) denotes the value of pin c.p's someProperty property.

3.3.1.1 Pin Data Interface

All pins have a data interface, denoted by interface(c.p). This corresponds to what is usually called the signature of a method and defined as a sequence of formal arguments $\langle name, type, mode \rangle$, where *mode* is one of {In, Out, InOut}, and *type* is one of {Boolean, SByte, UByte, SWord, UWord, SDWord, UDWord, SDouble, Float, String}. For simplicity, we do not define the representation of these types in this report.

3.3.1.2 Source Pins

There are two types of source pins: *asynchronous* and *synchronous*. Informally, an asynchronous source pin represents the ability of a component to make a request, where the component does not wait (or block) for the request to be satisfied. A synchronous source pin also represents the ability to make a request by a component, but in this case, the component must wait for the request to be satisfied. Asynchronous source pins are graphically denoted with the \blacktriangleright pin head, and synchronous ones use the \triangleright pin head. In Figure 6, c.r₁ is an asynchronous source pin, while c.r₂ is a synchronous source pin. It is reasonable to think of asynchronous source pins as *message sends* and synchronous source pins as *procedure calls*, but you shouldn't put too much faith in this gross interpretation; in fact, that is not how these pins were implemented in the SAS model solutions. Nonetheless, arguments in an asynchronous pin data interface must be of mode *In*.

If Mandatory(c.r), then c.r is a mandatory source pin; otherwise it is optional. Optional source pins need not be connected in an assembly, while mandatory source pins must be connected. This models the distinction between *uses* (mandatory) and *calls* (optional), respectively. A component c₀ uses sink pin c₁.s if the behavior of c₀ depends on the correct behavior of c₁.s; otherwise it only calls c₁.s. Graphically, we distinguish optional source pins from mandatory ones by enclosing the names of optional sources in square brackets ([]). So, c.[r₂] is an optional source pin in Figure 6.

3.3.1.3 Sink Pins

There are two types of sink pins: *asynchronous* and *synchronous*, referring to a component's ability to receive asynchronous or synchronous communication, respectively. As with source pins, the data interface of an asynchronous sink pin may include only arguments of mode *In*. Asynchronous and synchronous sink pins are graphically denoted with pin heads \blacktriangleright and \triangleright , respectively. In Figure 6, c.s₁ is asynchronous, while c.s_k, $2 \leq k \leq 6$, are synchronous.

If $\text{Threaded}(c.s)$, then $c.s$ has its own thread of control, and $\text{threadId}(c.s)$ denotes its identity. Threads represent units of concurrent execution and may be implemented by operating system threads, processes, tasks, and so forth. Graphically, $t_j = \text{threadId}(c.s)$ is denoted as a suffix : t_j on the sink pin name. In Figure 6, sink pins $c.s_2$ and $c.s_3$ are unthreaded. Threads may be shared by sink pins. So, in Figure 6, $c.s_5$ and $c.s_6$ share thread t_3 , but $c.s_1$ and $c.s_4$ have their own threads. Note that asynchronous sink pins must be threaded, that is, $\text{Asynchronous}(c.s) \Rightarrow \text{Threaded}(c.s)$.

If $\text{Mutex}(c.s)$, then $c.s$ is called a *mutex* sink, and only one caller may be active on $c.s$ at any given time—in effect, the caller must obtain the semaphore for $c.s$. Conversely, if $\neg \text{Mutex}(c.s)$, then $c.s$ is called a *reentrant* sink and is *never* guarded by a semaphore. Note that even a reentrant $c.s$ might force a caller to wait while $c.s$ synchronizes on an internal (to $c.s$) resource. This characteristic pertains only to synchronous sink pins. Mutex sinks are represented by \triangleright . In Figure 6, $\text{Mutex}(c.s_k)$, where $3 \leq k \leq 6$. Note that $\text{Threaded}(c.s) \wedge \neg \text{Asynchronous}(c.s) \Rightarrow \text{Mutex}(c.s)$.

3.3.2 Assemblies and Environments

An *assembly* is defined as a set of components and their connections. We denote an assembly as a_j , and $a.c$ denotes the component c in the scope of assembly a . An assembly is graphically depicted as a box enclosing a set of connected components, which visually reinforces the notion that assemblies are composed of components. Figure 7 depicts a simple assembly to illustrate key points in the following discussion.

A connection, or connector, is established between two components when some source pin $c_i.r$ is connected to some sink pin $c_j.s$, $i \neq j$ (this inequality is assumed in further discussion). Components c_i and c_j must be part of the same assembly if they are to be composed. In text, we denote the connection as $a(c_i.r \rightsquigarrow c_j.s)$, although we usually omit the $a()$ where doing so will not cause confusion. A connection $c_i.r \rightsquigarrow c_j.s$ requires that $c_i.r$ and $c_j.s$ be mutually conformant. The rule for mutual conformance is simple: both pins must be synchronous, or both must be asynchronous, and their data interfaces must have the same argument types, modes, and positions. Graphically, we denote a connection as a double-headed lollipop, with the lollipop heads circumscribing the connected pins. In Figure 7, $c_0.r \rightsquigarrow c_2.s$ is a connection.

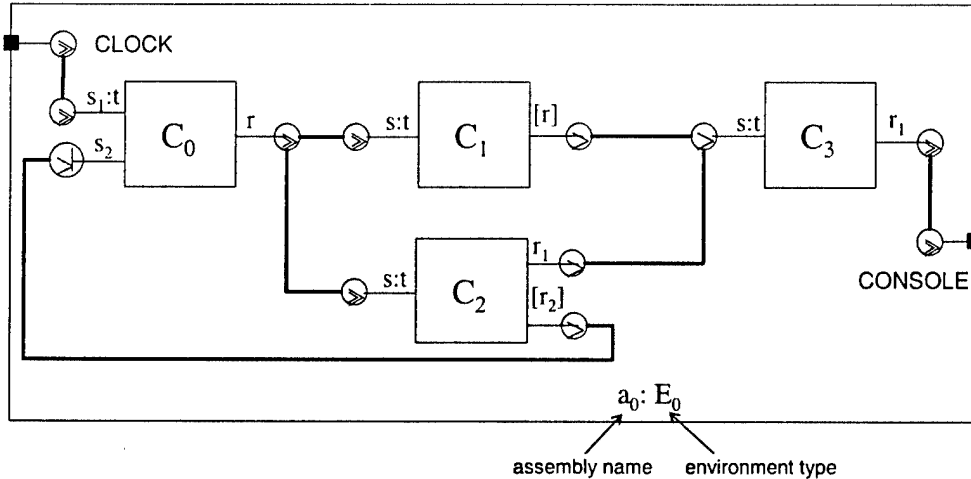

Figure 7: A Simple Assembly

Each assembly has an associated environment type, which is denoted by the $:E_j$ suffix of an assembly name. Environment types play two crucial roles in Pin. First, they define the services (specified as sink and source pins) that components may use. Graphically, these services are attached to the assembly by means of environment junctions, drawn as small black boxes. For example, in Figure 7, a runtime environment associated with assembly a_0 provides two services: the source pin `CLOCK` and the sink pin `CONSOLE`. The environment's services can be thought of as being implemented by an environment-provided component with a single sink pin ($a_0.CONSOLE$) and source pin ($a_0.CLOCK$). We denote a connection with an environment service in an analogous way to that defined earlier, that is, as $a_0.CLOCK \rightsquigarrow a_0.c_0.s_1$ and $a_0.c_3.r_1 \rightsquigarrow a_0.CONSOLE$. To make these expressions easier to read, we allow assembly names to distribute over \rightsquigarrow , so, instead of the above, we could write $a_0(CLOCK \rightsquigarrow c_0.s_1)$ and $a_0(c_3.r_1 \rightsquigarrow CONSOLE)$. Again, we might omit a_0 if doing so does not cause confusion.

Second, environment types supply the interaction models implemented by connectors. For example, consider the interaction topology in Figure 7 that includes

- $CLOCK \rightsquigarrow c_0.s_1, c_3.r_1 \rightsquigarrow CONSOLE, c_2.r_2 \rightsquigarrow c_0.s_2$
- $c_0.r \rightsquigarrow \{c_1.s, c_2.s\}$
- $\{c_1.r, c_2.r_1\} \rightsquigarrow c_3.s$

where we use sets $\{c.p_1, c.p_2, \dots\}$ to denote multiple sinks and sources on 1:N and N:1 compositions, respectively. The semantics of 1:1 composition (the first bulleted item, above) is likely to be clear intuitively, but what about the 1:N asynchronous composition (the second bulleted item)? How many connectors are there? Is a broadcast or a sequence of unicasts represented? If a sequence is, what is its order? What is the semantics of message buffering—first in, first out (FIFO) or last in, last out (LIFO)? What is the capacity of the message buffers? Analo-

gously, what is the interaction order of the N:1 synchronous composition? We may want different answers to these questions in different component runtime environments. Ivers and associates give a detailed treatment of how these semantics are defined [Ivers 02].

3.3.3 Behavior: Reaction and Interaction

In PECT, the semantics of composition is defined by analysis views. That is, we define the semantics of an assembly as the observable behavior of an assembly. Informally, the Pin syntax describes *what an assembly looks like*, while the semantics describes *what it does* at runtime. We say that Pin is *semantically extensible* since different syntactic elements of Pin may be annotated¹⁵ with information that is used to construct, via interpretations, the semantics of each assembly in the Pin style.

Nonetheless, one semantics is of such utility to predictable assembly that it is built into Pin—the behavior that is specifiable in a process algebra such as Hoare's CSP [Hoare 85], Magee and Kramer's FSP [Magee 99], or Milner's CCS [Milner 89] and π -Calculus [Milner 99]. We have chosen, at this time, to use CSP as the behavior specification language for Pin. In this report, we describe only the essence of our approach. For complete details on it, see *A Basis for Composition Language CL* [Ivers 02]. We first treat the specification of component behavior in the form of *reactions* and then treat the composition behavior in the form of *interactions*.

3.3.3.1 Component Behavior: Reactions

Components have intrinsic behavior, as defined by their implementations. We model the behavior of a component in terms of *reactions*. A reaction is a CSP process that relates one or more sink pins to one or more source pins, indicating how the component reacts to the stimulation of its sink pins. The general form is a process that looks something like $R = s \rightarrow r \rightarrow R$, where s is a sink pin that can be stimulated, r is a source pin that is stimulated in response to an interaction on s , and R is the CSP process that describes this pattern of behavior. Note that reactions are defined within the scope of a component, so the usual denotation of c.s, c.r, c.R and so on is superfluous.

Reactions also reflect the thread structure of a component. For example, all behavior implemented by a common thread is modeled as a single reaction. This allows analyses to take into account the actual degree of threading, and potential concurrency errors, of the component implementation. A component's behavior as a whole is specified as the CSP parallel (indicated by the \parallel symbol) or interleaved (indicated by the $\parallel\parallel$ symbol) composition of its reactions, depending on which better models the actual interaction among the component's threads.

15. The annotation mechanism or syntax is not described in this report.

The gist of reaction rules is depicted in Figure 8.

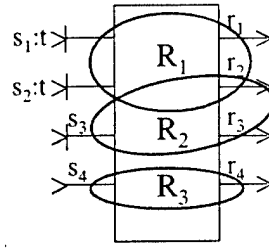

Figure 8: Reactions Specify Component Behavior

In this example, there are three reactions: R_1 , R_2 , and R_3 . The ovals are used to illustrate which pins are related by each reaction; for example, R_1 is shown as relating sink pins s_1 and s_2 to source pins r_1 and r_2 . R_1 represents the behavior of a single thread t that is used to process sinks s_1 and s_2 . A definition of R_1 could be $R_1 = (s_1 \rightarrow r_1 \rightarrow R_1) \square (s_2 \rightarrow r_2 \rightarrow R_1)$ where \square means *external choice*.

Reactions allow us to specify the causal dependencies among behaviors in an assembly of components. The most basic causal dependency is the *dependency chain*, as illustrated in the above reaction. In fact, this is the only causal dependency we required for the latency analysis in SAS model solutions. More complex behaviors, such as coordination among reactions or changes in behavior based on accumulated state information, can also be modeled.

3.3.3.2 Assembly Behavior: Interactions

Up to this point, we have been using the \rightsquigarrow operator in an informal manner. Although we never made the claim, the reader might infer that \rightsquigarrow has some sort of algebraic properties and associated composition semantics. A simple algebraic model for \rightsquigarrow might be $\langle R, \{\rightsquigarrow^{a^n} \bullet a^n \in E\} \rangle$, where R denotes reactions, and in place of the single operator \rightsquigarrow , we have a set of operators \rightsquigarrow^{a^n} , one for each (n^{th}) interaction scheme a^n defined for an environment E , where the operators of a^n may be of arbitrary arity.

So, for example, from Figure 7, the 1:N interaction $a_0(c_0.r \rightsquigarrow \{c_1.s, c_2.s\})$ denotes the syntactic composition of three components c_0 , c_1 , and c_2 , in assembly a_0 , on pins $c_0.r$, $c_1.s$, and $c_2.s$. The interaction scheme for this composition is \triangleright , as defined in environment type E_0 . We cannot tell whether \rightsquigarrow is a binary (unicast) or n -ary (broadcast) operator. This and other aspects of the semantics of this interaction must be formally specified.

Such specifications are not trivial, but there are specification patterns that can simplify them. One objective of *A Basis for Composition Language CL* [Ivers 02] is to produce a general approach for specifying the composition semantics for arbitrary interaction schemes (connectors) for arbitrary environment type E . We hasten to add here that end users of PECTs never

see these semantic complexities, any more than users of modern programming languages see the complexity of type checking or code generators.

3.3.4 Hierarchical Assembly

So far we have described a component model that is quite flat: components can interact only with components in the same assembly and only with a single runtime environment associated with that assembly. Pin will not scale to interesting problems without introducing some form of hierarchical composition. In fact, the algebraic model $\langle R, \{ \overset{a}{\sim} \bullet a^n \in E \} \rangle$ has a hierarchical meaning, because $R_3 = R_1 \overset{a}{\sim} R_2$ (for some arbitrary binary composition operator $\overset{a}{\sim}$ and reactions $R_{\{1,2,3\}}$) induces a hierarchy that is rooted at R_3 and composes R_1 and R_2 .

Hierarchical assembly in Pin always involves treating an assembly as a component. That is, the assembly has an interface defined in terms of source and sink pins. The correspondence between component pins and assembly pins is established by means of assembly junctions. Two forms of junctions are defined: *null* junctions and *gateway* junctions. We note at the outset that hierarchical composition introduces many subtle complexities not generally addressed by component technology. We do not discuss these subtle issues in this report because our focus is on the controller assembly only.

3.4 Pin Subset in SAS Model Solutions

The preceding description of Pin is more general and complete than the version of Pin used in the SAS PECTs—many of the generalities were a result of our experience. The following summarizes those aspects of Pin that were actually used:

- The operator PECT used Microsoft .NET as its component runtime, while the controller PECT used Microsoft Windows 2000 augmented with support for real-time, priority-based scheduling. Differences between these runtimes were reflected in the latency theories used, but not in composition semantics.
- The assembly environments for the operator and controller PECTs were conventional text editors operating on component and assembly descriptions written in Extensible Markup Language (XML).
- The operator and controller PECTs had an analysis environment in the limited sense that latency prediction was automated, and both had validation environments based on traces of time-stamped pin activations.
- All the pin types described in Section 3.3.1 were implemented. However, components were restricted to one thread of control that was shared by all asynchronous sink pins. Further, synchronous sink pins were not threaded.

- Sink pins were annotated (in XML) with execution time. Components were annotated with a single execution priority. Callers on synchronous, mutexed sink pins would acquire the priority level of the called component.
- The notion of assemblies was implicit—although assemblies were units of deployment, they were not named entities. Environment types did not appear at all. Environment services, such as periodic timers, were implemented as environment-provided components.
- OPC gateway junctions were used to (hierarchically) compose an assembly of the operator PECT with an assembly of the controller PECT; analysis hierarchies using null junctions were not used.
- The CSP reactions were specified, on paper, for each controller component. These reactions were then used to manually construct the models used in the temporal-logic model checking, as described in Chapter 7 and Appendix C, and the ordering of interactions over 1:N connection topologies for controller latency prediction.
- There were no formal compositional semantics defined for the connectors.

3.5 SAS Software Controller in Pin

Figure 9 depicts the SAS software controller developed in Pin for this model problem.

The names and functional roles played by the components in Figure 9 (i.e., CSWI, TCTR, TVTR, MMXU, XCBR, and PIOC) are defined by the IEC 61850 standard. SwMonSource and SwMonSink manage the interface to the hardware switch, Clock is a component that is (logically) bundled with the λ_{ABA} latency model, and OPCGateway allows us to create an assembly of assemblies—one that allows the operator and controller assemblies to interact using the OPC protocol.

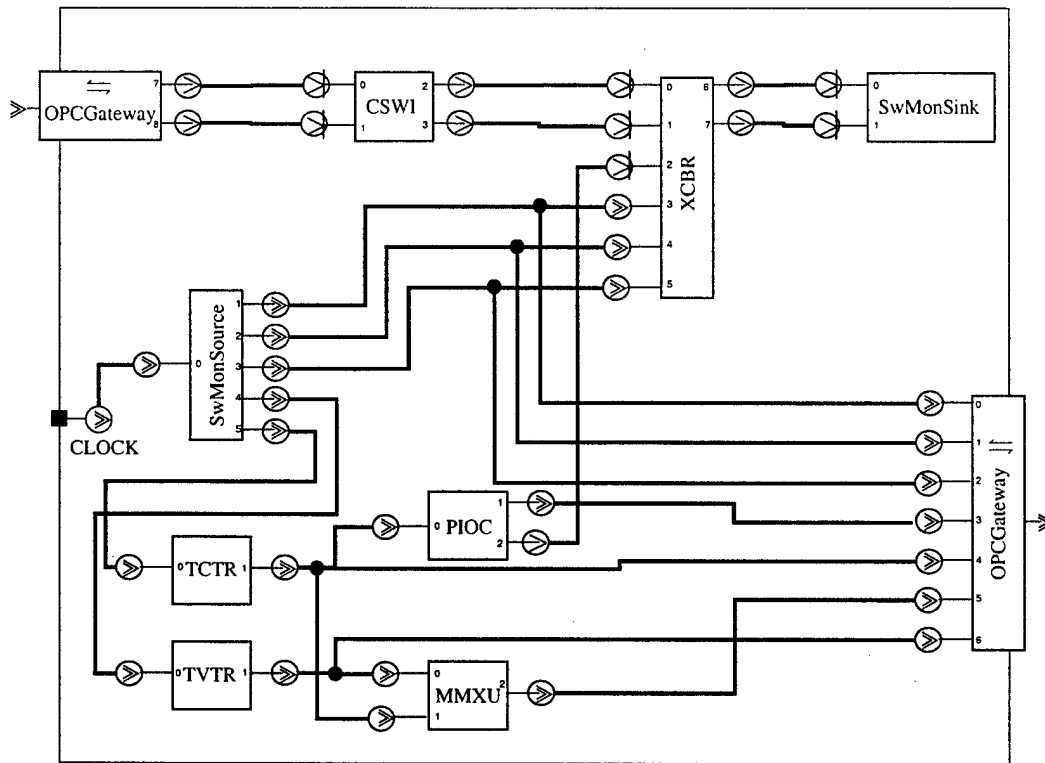

Figure 9: SAS Software Controller in Pin¹⁶

16. Each component in this figure had at most one thread of execution that was shared among all asynchronous sink pins. Those threads are not depicted in this figure for the sake of simplicity.

4 PECT Process and Workflows

4.1 The PECT Development Process

We develop and validate a PECT using a process that consists of four fundamental phases:

1. Definition
2. Co-Refinement
3. Validation
4. Packaging

During the Definition phase, we define the functional requirements, the assembly property to analyze, and the statistical goals for the PECT. Once those goals have been set, we create a component model, an analysis model, and a measurement framework through an iterative process known as co-refinement. A PECT instance, which integrates the component and analysis models, emerges from co-refinement. During the Validation phase, we validate the PECT instance against the defined goals. If it meets the goals sufficiently, the PECT is packaged and released. If the goals are not met, co-refinement is repeated until they are. Figure 10 shows a brief overview of the PECT process. As the arrows indicate, this process is highly iterative.

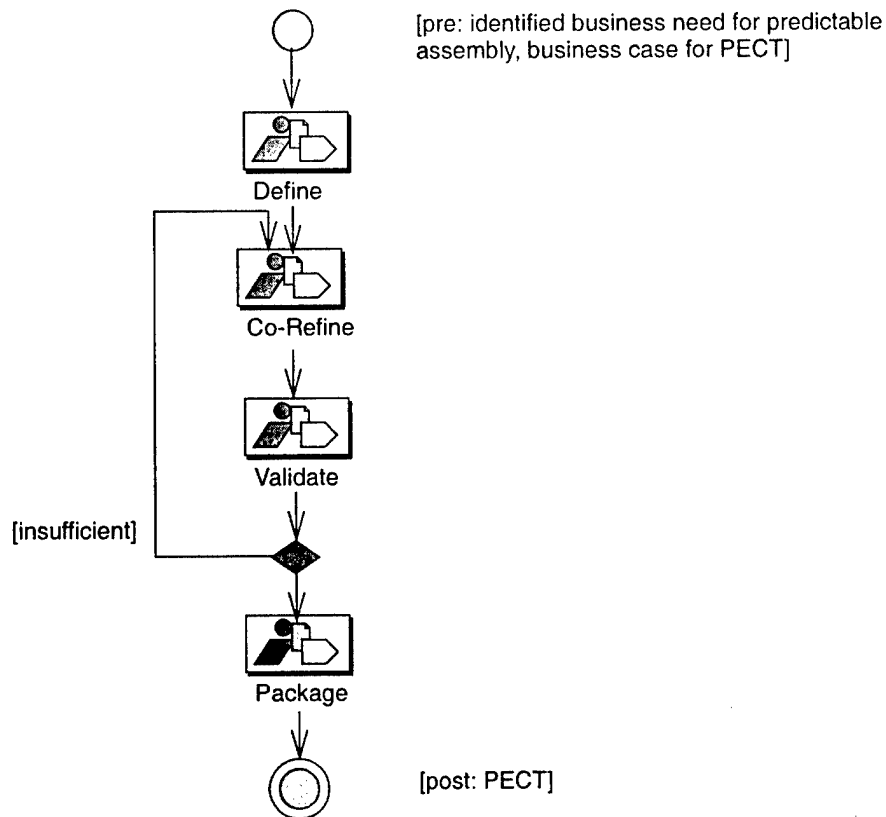

Figure 10: An Overview of the PECT Development Method

In the following sections, we translate the PECT process concretely into (using Kruchten's terms) deliverables, workers, activities, artifacts, and workflows [Kruchten 00]. Deliverables constitute the primary output of the PECT process. Workers are those involved in performing the PECT process. Artifacts describe what is produced during the PECT process. Activities describe how the PECT process is accomplished, and workflows provide insight into when in the process they occur.

4.1.1 Deliverables

The outcome of the process is a PECT that consists of

- a component technology
- one or more analysis views and their associated interpretations
- a validation environment or other means of establishing trust in analysis and predictions
- validation data and statistical labels

The delivered PECT has the following characteristics:

- zero programming assembly
Components can be assembled into applications without additional programming. If additional code has to be provided, the code must be encapsulated in PECT-compliant components.
- automatic interpretation
To perform predictions in an execution environment where the end assemblies are unknown, the PECT must be able to interpret a constructive assembly into an analysis view automatically. The analysis view is then used to perform the desired prediction.
- objective trust
Objective trust is achieved by validating the prediction theory using a wide variety of assemblies. Statistical means can be used to calculate how many assemblies have to be executed to meet the statistical goals set for the prediction theory.

4.1.2 Workers, Activities, and Artifacts

In the Rational Unified Process (RUP), an activity is generally assigned to a specific worker and has a duration of a few hours to a few days [Kruchten 00]; we relax this stipulation somewhat and allow multiple workers to contribute to an activity, where that activity has an indeterminate duration. As with the RUP, each activity has a clear purpose, usually centered on creating or modifying artifacts—the tangible products of the PECT development method.

Table 2 depicts the major artifacts of the PECT development process that are the result of workers performing activities. The fact that each artifact is assigned to just one worker should be interpreted not as an exclusive assignment, but rather as an assignment of primary responsibility. In general, multiple workers are required for most artifacts. For example, defining the requirements for a PECT is primarily the responsibility of the customer, but setting the appropriate requirements requires the contributions of the PECT designer, attribute specialist, and component model specialist.

Table 2: *PECT Development Activities*

Activity	Workers	Artifacts
Define functional requirements	customer	PECT requirements
Define assembly property	customer	assembly property definition
Define statistical goals	customer	normative confidence labels
Define component model	component model specialist	constructive viewtype
Define analysis model	attribute specialist	analysis viewtype
Define property theory	attribute specialist	property theory and its validation concept

Table 2: PECT Development Activities (Cont'd.)

Activity	Workers	Artifacts
Validate theory empirically	measurement specialist	experiment design, statistical labels
Develop analysis interpretations	PECT designer	component and assembly description schemas; interpretations
Develop component measurement apparatus	component developer measurement specialist	test components (synthetic, actual) testbench for component and assembly measurement
Develop assembly measurement apparatus	measurement specialist	assembly generator and analysis tools
Create validation sample	component developer application assembler	any additional assembly components sample assembly set
Obtain component measurements	measurement specialist	component measurements (labels)
Obtain assembly measurements	measurement specialist	assembly measurements and analysis (labels)
Deploy PECT	PECT designer	packaged PECT

Below, we describe workers whose roles are not implicitly clear by their names alone:

- **component model specialist:** defines the constructive viewtype used in the PECT. This person may or may not be the designer of a proprietary component technology. Either way, if the component technology has already been defined, this specialist will have in-depth knowledge about it.
- **attribute specialist:** defines and helps to validate both the property theory and the analysis model. This person must know the theories behind the chosen attribute (emergent property) that the PECT is engineered to predict. For example, if the attribute is latency, the attribute specialist would likely have in-depth knowledge about real-time performance and how to analyze for performance.
- **measurement specialist:** develops both the component and assembly measurement apparatus and obtains the component and assembly measurements. This person must know how to measure and empirically validate the property theories in the PECT and would typically have broad knowledge of statistical methods.
- **PECT designer:** unifies the constructive and analysis models through co-refinement (as manifested in the analysis interfaces) and then packages and deploys the PECT. This person holds the holistic view of the PECT and communicates with the other workers to keep the various parts of the PECT development synchronized.

In addition to those workers actually involved in the PECT process, two other roles are key to its successful execution:

- system specialist: has in-depth knowledge about the execution environment that usually affects the behavior of the components residing in the PECT. For example, the PECT may need to be designed to restrict the use of the operating system to meet the set goals.
- domain expert: knows how the PECT will be used from the end customer's perspective and provides input about existing standards, methods, and user profiles. This role is important, because it helps to ensure that the PECT's design will fit the system's intended usage.

4.2 Workflows

The workflows in this section are elaborations of the PECT overview workflow shown in Figure 10 on page 26.

4.2.1 Definition Phase

The workflow shown in Figure 11 is an elaboration of the Define process shown in Figure 10. The Definition phase has two parallel paths—one to define the functional requirements and another to gather the necessary requirements for the property of interest and set the PECT's prediction goals.

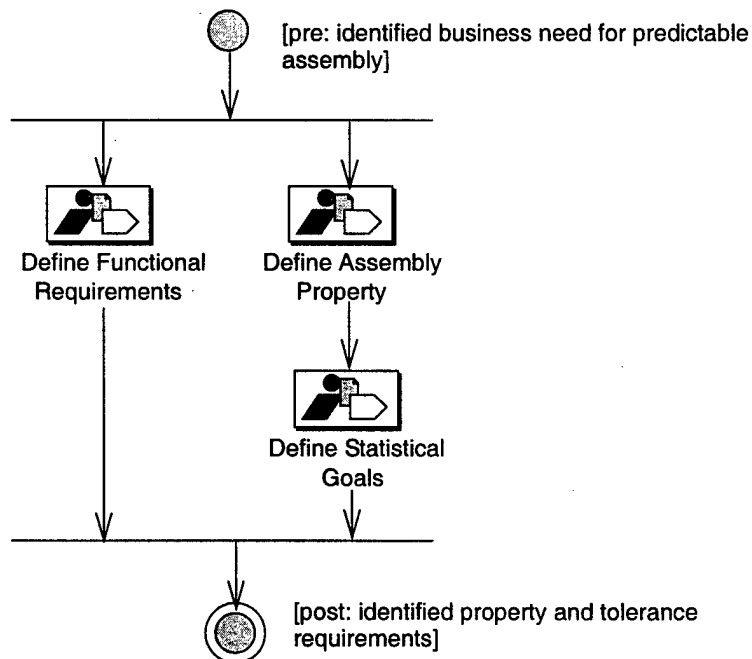

Figure 11: Definition Phase Workflow

Statistical goals should be based on the business need. Because producing it takes effort, a PECT should be only as general as necessary to fill that need.

4.2.2 Co-Refinement Phase

During the Co-Refinement phase shown in Figure 12, we define the constructive and analysis viewtypes, and the interpretation that integrates them. We also define a plausible and possibly high-level scheme for validating predictions based on the analysis viewtype.

The workflow depicted suggests a process that is somewhat more structured than what occurs in actual practice. The constructive and analysis viewtypes are depicted as being developed in parallel, but they are, in fact, mutually constraining, as explained and illustrated in Chapter 5. In our experience, considering validation places useful constraints on the development of the analysis viewtype, so we placed “Define Validation Concept” at the same level of activity in the workflow as “Define Constructive Viewtype” and “Define Analysis Viewtype.” A similar argument can be made for placing “Define Interpretation” alongside “Define Validation Concept,” although our experience suggests that defining the interpretation is usually the closing step in a co-refinement iteration.

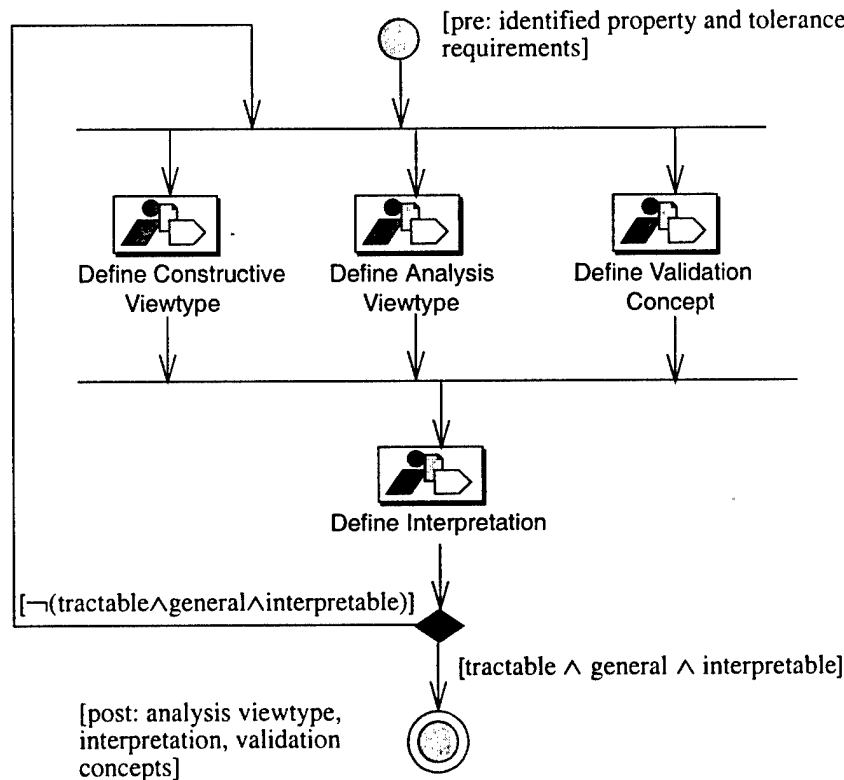

Figure 12: Co-Refinement Workflow

The iteration within the co-refinement workflow must not be confused with the iteration that results from the empirical validation shown in Figure 13. Within co-refinement, the condition for iteration is an assessment of whether the resulting constructive assembly is sufficiently general to handle an anticipated range of assemblies and whether the property theory underlying the analysis viewtype will, with reasonable computation and interpretation effort, yield predictions for all these assemblies.

4.2.3 Validation Phase

After co-refinement, the resulting PECT is validated against its requirements. The definition workflow shown in Figure 11 identifies functional requirements and tolerance requirements. Functional requirements define the range of assemblies that must be “spanned” by the constructive model and its interpretations; the tolerance requirements refer to the desired quality of predictions based on the analysis viewtypes supported by the PECT. The workflow shown in Figure 13 is biased toward the validation of analysis viewtypes whose underlying property theories are empirical (i.e., based in measurement) rather than formal (i.e., based in logic). As this workflow is currently defined, it addresses the validation of both functional requirements and statistical goals.

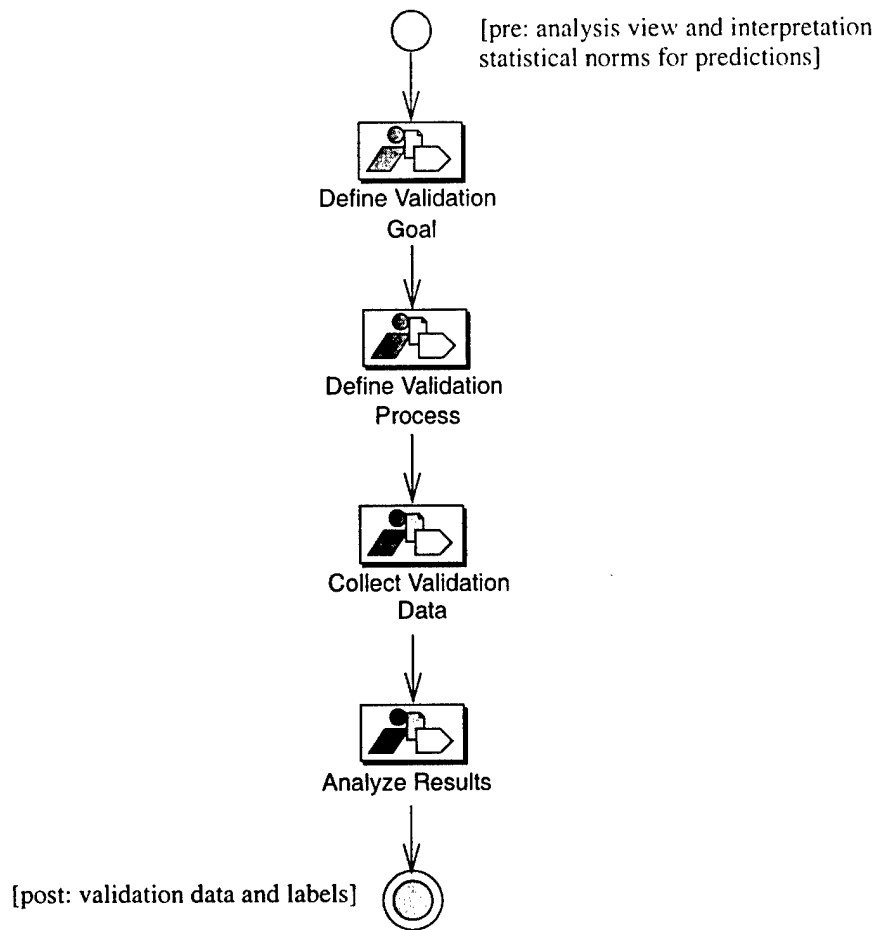

Figure 13: Empirical Validation Workflow

There are four general aspects to carrying out an empirical validation study:

1. Define the validation goal.
The goal is a normative or informative statement about the predictive power of the PECT. Typically, a goal is stated in terms of the probability that a prediction will lie within some accuracy bounds, with some stated confidence level.
2. Define the validation process.
Validating the accuracy of a prediction is analogous to validating a scientific theory. That is, behaviors are observed systematically under controlled circumstances, and this observed behavior is then compared to predicted behavior. The key word is systematic, since validation results should be, above all else, objective and hence repeatable.

3. Collect validation data.

This step involves conducting the actual validation experiment. Important in this activity are good laboratory techniques—for example, keeping good notes and records so that anomalies can be studied and results can be repeated.

4. Analyze the results.

The purpose of the analyses is twofold: first, to objectively and reliably describe the predictive powers of a PECT; second, to provide analysis data to support additional co-refinement, should normative goals fail to be satisfied.

This workflow is expanded considerably in Chapter 6.

4.2.4 Packaging Phase

The workflow for packaging is a lacuna at this time. The objectives of packaging are twofold. One objective is to ready the technology for deployment, including the development of installation support, documentation, and so forth. A second and more fundamental objective is to design automation support for the PECT to minimize the property-theory-specific expertise required by PECT users to make effective use of analysis viewtypes supported by the PECT. This area requires further work.

5 Co-Refinement of the Controller PECT

5.1 What Is Co-Refinement?

PECT creation is a process of iterative negotiation between the constructive and analysis points of view. We call this process *co-refinement*. Co-refinement does not necessarily follow a rigorously defined process, but rather it is channeled by a set of forces that guide co-refinement as the two points of view (models) converge into a PECT.

The constructive point of view pushes for assembly generality; the more assemblies that can be represented in the constructive model, the better. The analysis point of view pushes for predictability, which implies constraining the constructive model to adhere to the assumptions of the property theories that enable analysis and prediction. These forces tend to act in opposition to each other.

Practicability, tractability, and interpretability also weigh in as important forces and act as moderators. *Practicability* pushes for a level of generality that is necessary (but no *more* than necessary) to represent some class of realistic system; it acts as a bounds on generality. *Tractability* is concerned with the level of difficulty in solving the analysis model; it acts as a bounds on predictability. For example, it might not be viable to require a supercomputer to solve the analysis model. *Interpretability* ensures that automatic translation from the constructive model to the analysis model is possible. This possibility implies the ability to formally specify both models and to translate the constructive representation into the analysis representation. *Validatability* is concerned with the level of difficulty in obtaining empirical validation of the analysis model.

5.2 How Co-Refinement Proceeds

The co-refinement process starts with an initial, not necessarily formal, description of the “languages” for the constructive and analysis models. The elements of the constructive model language are influenced by the PECT’s target domains and how systems in those domains will be structured, developed, deployed, and sustained (evolved) over time. The elements of the analysis model language are simply a subset of some property theory that is suitable for analyzing the behavior of interest.

Initially, each model is independently subjected to its own starting criteria. The constructive model¹⁷ has to be expressive enough to describe the types of components and interactions expected in the domains that will use the PECT. However, initially, the constructive model might not be interpretable vis-a-vis the analysis model, and the analysis model might not be general enough to account for all aspects of the constructive model.

Given a starting point for the constructive and analysis models, the forces guide co-refinement as the initial models converge into final models that define the PECT. While there is no precise set of steps for determining the sequence of intermediaries from the initial models to the final models, there are some rules of thumb.

Generality increases monotonically. After the first iteration, the PECT designer should have reasonable confidence that the constructive model is interpretable and that the analysis model is tractable. Therefore, the dominant force in co-refinement at this point is moving the constructive model to the desired state of generality. The only reason to reduce generality would be if the designer's confidence in interpretability proved to be unwarranted.

Interpretability increases monotonically. While co-refinement might not start with interpretability, it must end with it. This leads us to believe that interpretability must monotonically increase as co-refinement proceeds. This means that, during co-refinement, the languages describing the constructive and analysis models, and the interpretation rules become more formal. In addition, a translator for the constructive model is developed iteratively as co-refinement proceeds.

Validatability is an invariant. Validatability is a defining characteristic of a PECT. Unlike generality and interpretability, however, it is important that all analysis models be validatable, at least in principle, for each iteration of co-refinement. By *in principle*, we mean that there must be a plausible means for obtaining or validating component properties, and for falsifying predictions made in the analysis model. While plausibility is not an objective quality, it is one that has a reasonable intuitive meaning.

Using these rules, co-refinement drives for increasing generality in the constructive model until all the following stopping conditions are met:

- The practicability boundary is reached—striving for more generality is not worth it.
- The interpretability boundary is reached—an automatic translation becomes impossible.
- The tractability boundary is reached—because of its complexity, solving the analysis model is too costly.

This iterative scheme was depicted in Figure 12 on page 30.

17. The terms *constructive model* and *constructive model language* are used interchangeably in this report.

5.3 Key Ideas for the Controller PECT

Performance is important in the intended domain for this PECT—power station control. Sensor inputs are gathered at various rates, inputs are coalesced, and actions are taken depending on the input values. Computations must adhere to both worst-case and average-case latency requirements. Typically systems are multiprocessing on a single processor or multiprocessors, connections can be both synchronous and asynchronous, and some data stores must be updated atomically.

The property theory for the controller PECT is based on rate monotonic analysis (RMA) [Klein 93]. RMA is well suited for predicting worst-case latency for a collection of processes on a single processor in a mostly (but not solely) deterministic situation; events occur mostly periodically, and process execution times are bounded and do not vary dramatically. RMA requires information such as process periods and execution times and priorities; whether mutually exclusive access to shared resources is needed; whether there are intervals of nonpre-emptability; and whether each process has a unique priority. In general, RMA strives to account for any factor that can contribute to latency—the time interval from when an event occurs until it has completely been processed.

5.4 Co-Refinement of the Controller PECT

This section describes the starting state (initial condition) for each model and then walks through the five iterations of the co-refinement process, leading to λ_{ABA} , the property theory whose validation is the subject of Appendix B. For each iteration, constraints on the constructive model and model semantics (i.e., what is predicted) are described. The five iterations are

- predicting worst-case latency (λ_W)
- predicting average-case latency (λ_A)
- introducing mutual exclusion and worst-case blocking (λ_{WB})
- predicting average-case blocking (λ_{AB})
- introducing asynchrony (λ_{ABA})

It should be noted that this is an *a posteriori* examination of a co-refinement experience. *A priori*, you would not expect to know the specifics of each iteration or how many iterations are required.

5.4.1 Initial Conditions

The initial constructive model was relatively simple. It consisted of a collection of components, where each component had a set of source and sink pins. Since concurrency was known to be important, each component could have either no threads or one thread associated with

it.¹⁸ Since some components had to be activated periodically, there was a special source pin that was denoted as periodic. Naturally, these components were threaded. Sink pins could be either reentrant or non-reentrant. Both synchronous and asynchronous connections were allowed.

The analysis model is based on a collection of real-time analysis techniques known as RMA for predicting worst-case latency. Latency is the measure of how long it takes to service an event. For example, we consider reaching a voltage sensor's read time as the occurrence of an event. Servicing the event comprises all the computations that are necessary to respond to the event, such as acquiring input from the sensor, converting the input to a number with some physical meaning, filtering noise, combining the input with other data, testing the data against some important physical conditions, and then issuing some output. These computations take place on a single processor that is also servicing other events. Latency is how long it takes from the voltage sensor's read time (not necessarily when the sensor is actually read) to the completion of the response to the event.

The initial analysis model used a subset of the modeling capabilities of RMA including

- considering only periodic events, that is, those that occur at regular intervals
- each periodic event is allocated its own process (or thread)
- each process is assumed to have a constant, unique priority
- the variability of the execution time for any given component is bounded
- the worst-case latency of all events is less than or equal to the period
- only reentrant, synchronous connections are allowed
- no blocking is allowed (sources of blocking include critical sections and nonpreemptable sections)

5.4.2 First Iteration: Worst-Case Latency (λ_W)

Tractability and interpretability were the dominant forces during this iteration. They caused us to both extend the constructive model with the annotations necessary to provide the analysis model with the needed information and to constrain the constructive model to conform to the restrictions of the initial conditions of the analysis model. The annotations included

- specifying execution times as properties
- specifying unique priorities for each thread. This turned out to be a significant restriction, because Windows imposed severe limitations on the number of priority levels.

18. This has since been generalized. See Section 3.3.1.

Modifications to the constructive model involved mainly the thread model. Since periodic invocations were important, we decided to extend the constructive model with an explicit notion of time using an environment component, the clock component. This extension eliminated the need for a periodic source pin. Also, since the analysis model was not considering blocking during this iteration, we disallowed threaded components, because they would have resulted in non-reentrant components and hence blocking. The constructive model was also constrained to allow only synchronous calls, conforming to this restriction of the analysis model.

With these restrictions to the analysis model, the worst-case latency for each process could be calculated using the following fixed-point calculation:

$$L_{n+1} = \sum_{j=1}^{i-1} \left\lceil \frac{L_n}{T_j} \right\rceil C_j + C_i$$

This formula can be used to compute the worst-case latency L_i for the i th process. C_i is the execution time of the i th process; T_i is the period of the i th process. Processes 1 through $i-1$ are assumed to be all the processes whose priorities are higher than that of process i . The iterative calculation starts by using C_i as the first guess for the worst-case latency by setting L_1 to C_i . Then it computes L_{n+1} using the formula above. It continues until $L_n = L_{n+1}$, at which point the fixed point has been reached, and L_{n+1} is the worst-case latency.

The interpretation from the constructive model to this analysis model (the above formula) is straightforward. Execution time (associated with sink pins), periods (associated with clock components), and priority (associated with threads) all map directly to the formula. The only complication occurred for the case in which a clock component initiates a sequence of component calls, as shown in Figure 14.

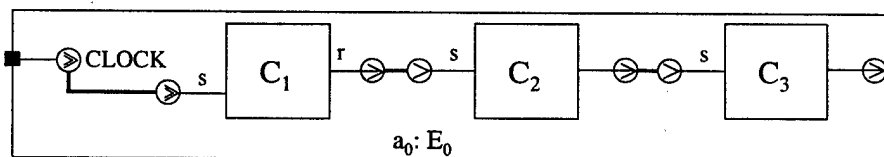

Figure 14: Clock Component Initiating a Sequence of Interactions

In this case, the period of the clock corresponds directly to the period of process i in the analysis model, the priority of component c_i corresponds to the priority of process i in the analysis model, and the sum of the execution times of components c_1 , c_2 , c_3 , and so on, corresponds to the execution time of process i .

At this point, we did not yet have an automatic translation from the constructive to the analysis model, but we did have a high degree of confidence that such a translation could be created.¹⁹

5.4.3 Second Iteration: Average Latency (λ_A)

For the second iteration, practicability started to exert influence mainly in terms of the need of the constructive model to satisfy average-case latency requirements in addition to worst-case latency requirements. Another facet of practicability influencing this iteration was the realization that the zero-phasing²⁰ assumption of the analysis model was not realizable in the constructive model. Therefore during this iteration, the constructive model did not change; the analysis model evolved to predict average-case latency and to handle non-zero phasing.

Zero phasing is significant because a key idea of RMA is that worst-case latency occurs for process i when it becomes ready to execute at exactly the same time that all higher priority processes do. The fixed-point formula shown in the previous section computes worst-case latency assuming zero-phasing. If the constructive model does not in fact adhere to zero phasing, the prediction might produce a result that is too pessimistic. Accounting for non-zero phasing requires only minor changes to the fixed-point formula shown in the previous section. These changes were made during this iteration.

A more substantive change to the analysis model was required to calculate average latency. The critical observation was that the execution profile of process i repeats itself. The interval of repetition (known as the hyper-period) is equal to the least common multiple (LCM) of T_1, T_2, \dots, T_i . Every NP period, process i 's performance behavior repeats, where $NP_i = \text{LCM}(T_1, T_2, \dots, T_i)/T_i$. Therefore, the latency for the first instance of process i should be the same as the latency for the $1+NP_i^{\text{th}}$ instance. To calculate the average latency for process i , we simply compute the average of the NP_i instances of process i during a hyper-period. The fixed-point calculation above had to be generalized to work across the hyper-period instead of just stopping after the first instance of the job.

At this point, we performed a "spot validation" of the interpretation and analysis model. That is, we constructed a small experiment, consisting of a small sample (< 5 simple assemblies) to see if we were predicting average latency accurately. The results were encouraging.

19. Although rewrite rules were possible, we chose not to implement them, because the generality of this approach to interpretation was not clear.

20. We say two or more events are zero-phased in time when they happen at the same moment (i.e., there is no time delay between them). In the context of the controller PECT, zero-phasing means that process i will become ready to execute at the exact moment all higher priority processes become ready to execute (the critical instant).

5.4.4 Third Iteration: Worst-Case Latency + Blocking (λ_{WB})

During this iteration, practicability continued to be a dominant influence. The controller domain required non-reentrant execution within components to ensure data consistency.

During the first two iterations, the only influences on process latency (in theory) were its own execution time and preemption from higher priority processes. With non-reentrancy, a higher priority process might have to wait while a lower priority process is executing a non-reentrant component. This effect is known as blocking. It prolongs latency and must be accounted for in the analysis model.

To account for blocking in the analysis model, a blocking term is simply added to the expression on the right side of the worst-case latency equation shown on page 39. However, the real issue is how to control the magnitude of this term. To do so, we impose a restriction on the constructive model that is based on another key result of RMA. One of the synchronization protocols discovered by RMA is the *priority ceiling protocol*. That protocol exhibits an important property known as the *blocked-at-most-once* property, which says that a process that executes in several critical sections can be blocked in, at most, one critical section.

The priority ceiling protocol requires that when more than one component interacts with a non-reentrant sink pin, the thread for that sink pin must execute at a priority level that is at least as high as the priority of the effective thread of any of the calling components. This priority level is known as the *ceiling priority*. Note that for this priority assignment to emulate the priority ceiling protocol, the thread that is assigned this priority cannot suspend for any reason, including input/output (I/O).

The prediction obtained using the priority ceiling is a worst-case prediction with respect to blocking, because a blocking term is used for every job in the hyper-period, regardless of whether the job is actually blocked during its execution. Assemblies must honor the priority ceiling to be well formed with respect to λ_{WB} . Since the constructive model has no concept of priority, it is the interpretation rather than the constructive model that enforces this topological constraint.

5.4.5 Fourth Iteration: Average Latency + Blocking (λ_{AB})

The goal of this iteration is to calculate average latency in the presence of blocking, taking into account the possibility that blocking will occur only for a portion of the jobs in a hyper-period. The initial challenge for this iteration was deriving a variation of the fixed-point calculation that could also determine when blocking did and did not occur. To make this determination, the notion of a subtask was introduced. A subtask is a portion of a component's computation distinguished by its priority; different subtasks have different priorities.

At this point, a purely analytic approach became unwieldy—in fact, nearly intractable. However, the analysis model yielded to a hybrid simulation-based approach [Schwetman 78]. In a hybrid simulation approach, an analysis model is used to compute values that define initial or test conditions in a simulator. Details of the hybrid simulation are provided in Appendix A.

At this stage, a formal interpretation was defined. Although we knew that the average-case latency theories were, in principle, validatable, it was by no means clear that the earlier spot validation would scale from λ_A to λ_{AB} . The PECT was not yet sufficiently general, since it did not accommodate assemblies with asynchronous pins. This led to the final iteration.

5.4.6 Fifth Iteration: Asynchronous Interactions (λ_{ABA})

The previous iterations had all involved adding new terms and features to the analysis model, and introducing or removing constraints on the constructive model to accommodate those additions. At this point, it was clear that the final and necessary step of the co-refinement process would be to relax the prohibition against asynchronous pins. It was unclear at this point how this constraint could be relaxed, or how much its relaxation would affect the analysis model or simulation. Our great fear was that it would result in some kind of fundamental discontinuity, effectively demonstrating that the basic RMA approach was insufficient or vastly complicating the simulator (loss of tractability).

Our fears proved to be unfounded, however. We made the fortuitous discovery that we could, through the application of rewrite rules, transform a constructive assembly with an arbitrary topology of asynchronous interactions into a behaviorally equivalent one (from the perspective of latency computation) with a more restrictive topology, as with synchronous pins only. These restrictions simplified the interpretation and preserved the hybrid simulation model. Thus, we were able to introduce asynchrony to the latency model strictly through rewriting and interpretation.

6 Empirical Validation

6.1 What Is Empirical Validation?

There are two classes of property theory: those based in logic and those based in measurement. Logical property theories, such as those found in model checking and other forms of program verification, involve demonstrative reasoning: the validity of a property is mathematically demonstrated, or proven, in a way that bars contradiction. Empirical property theories, such as λ_{ABA} , involve plausible reasoning: the validity of a property theory is established inductively, based on observations.

The fact that empirical theories are based on observations and measurement introduces uncertainty. The property theory itself may abstract aspects of an implementation that influence the assembly-level property. This, in turn, introduces variability and some degree of non-determinacy, for we cannot give a systematic accounting of an abstracted system aspect without undoing the effect of its abstraction.

Empirical validation is the means by which we validate empirical property theories. The validation does not yield a simple “yes” or “no.” Instead, it produces statistical evidence of a property theory’s effectiveness and of the component property measures on which the validation’s predictions are based. Before describing the workflow for empirical validation in Section 6.3, we provide a brief overview of the statistical models used to express statistical evidence.

6.2 Introduction to Statistical Labels

Rigorous observation takes the form of measurement, and measurement invariably introduces error. Thus, measured component properties are described not as discrete values, but as probability density functions over a range of values. As was the case with component properties, measured assembly properties are described using probability density functions over a range of values. Likewise, determining the effectiveness of a property theory also involves measurement, this time in a more classical application of the scientific method. The property theory is a hypothesis; it is tested by comparing assembly properties predicted by the hypothesized property theory with observed assembly properties.

We refer to the statistical descriptors of component properties and property theory effectiveness as *statistical labels*. Our position is also that all empirical properties and property theories

can be described in a uniform way, using the same, or very similar, statistical models, resulting in standard labels.

6.2.1 Component Labels

The measurement and subsequent description of empirical component properties do not introduce novel methodological challenges. Objective measurement requires a measurement object (the component), a measurement scale for the component property of interest (e.g., time, in seconds), and a measurement apparatus (e.g., the Microsoft Windows' high-performance clock). Measurement is conducted using the apparatus within some controlled environment and with control exerted over all independent variables of the dependent (measured) property.

Component Property Estimators

In general, the measurand Y , or property of interest, is a function of N values:

$Y = f(X_1, X_2, \dots, X_N)$ [Taylor 94]. For latency, these values include execution time, blocking time, and period. We would like to know the *true* value of Y , component latency. Of course, the true value is not obtainable, as the following definition makes clear:

True Value: the mean (μ) that would result from an infinite number of measurements of the same measurand carried out under repeatable conditions, assuming no systematic error.

Because we cannot, even in principle, know the true value of μ , we must use an estimator for it, one that is produced by statistical methods.

For example, we take sample observations of X and use their average \bar{x} as the estimator of μ , a population parameter. The uncertainty associated with this estimator is expressed as the deviation s such that the true—and unknown—value of μ will fall within some interval $\bar{x} \pm ks$ with some specified confidence. The factor k is known as the *coverage factor*. When $k=1$, $\bar{x} \pm ks$ yields a 68% confidence interval (one standard deviation). That is, we have 0.68 confidence that this interval contains μ . Typically, we compute the 0.95 confidence interval ($k=2$), which yields higher confidence but a larger bound. This confidence interval expresses a fundamental component measure; it is fundamental because $\bar{x} \pm ks$ is how a component property is modeled in any property theory parameterized by that component property.

Component Property Intervals

It might be useful to have other descriptors, or labels, for component properties. One such label is the *tolerance* interval. For example, in the case of component latency, the consumer might want to know which latency interval $\pm x ms$ contains a specified proportion p of all executions of component c . For instance, a tolerance interval with $p=0.95$ might state that there is

a 0.95 probability that any given component's execution will have a latency of $50\text{ms} \pm 17\text{ms}$, where $\pm 17\text{ms}$ is the computed tolerance interval.

Another potentially useful label is the conceptual, but not mathematical,²¹ inverse of the above tolerance interval. This label is the confidence interval on the probability of satisfying some property specification. Conceptually, this label is the inverse of the tolerance interval, since we specify the latency interval here and use it to compute the probability that any particular execution will fall within this interval. For example, we might specify the latency interval $\pm 5\text{ms}$ and use it to calculate that there is a 0.64 probability that any given component's execution will fall within the interval $50\text{ms} \pm 5\text{ms}$.

6.2.2 Property Theory Labels

Measuring and describing the effectiveness of property theories is methodologically more challenging than measuring component properties. As noted earlier, at the limit, this measurement process reduces to theory falsification as it is practiced in the empirical sciences; in that sense, at least, no new ground is broken. Our concern is with characterizing (labeling) the quality of a property theory. Such a characterization translates into labeling the accuracy of the theory's predictions and determining how often they are accurate.

One-Tail Inferential Intervals

We use inferential statistical models to characterize how effective a property theory is likely to be for future predictions. For this purpose, we use confidence and tolerance intervals. For property theories, we are usually interested in the MRE between predicted and observed values. For latency, this equation is used:

$$\text{MRE} = \frac{|a.\lambda - a.\lambda'|}{a.\lambda'}$$

where $a.\lambda'$ is the measured assembly latency and $a.\lambda$ is the predicted latency.²² A normative confidence interval will describe the probability that the MRE for a particular prediction will lie within a specified MRE interval.

Notice that the lower bound for an MRE interval represent situations where predictions are better than the mean MRE of the statistical sample (i.e., in our experiment, for $N=30$ assemblies). While we might want to know how frequently our predictions are better than the mean, we might be concerned only when the predictions are worse than the mean. In this case, we

21. Different equations are used to compute conceptual and mathematical intervals.

22. We note in passing that $a.\lambda'$ is described using the fundamental label for components. That is, for statistical analysis, the assembly is treated as a component, and the estimator for assembly latency is described by an interval obtained using a coverage factor $k=2$.

use a one-tail interval, or bound, instead of a two-tail interval. The one-tail tolerance interval for λ_{ABA} is summarized in Table 3.

Table 3: *Distribution-Free Tolerance Interval for λ_{ABA}*

Part of Interval	Description
N = 65	sample size
$\gamma = 0.9942$	confidence level
p = 0.80	population
$\mu_{MRE} = 0.04$	MRE
UB = 10%	upper bound

The tolerance interval for λ_{ABA} can be interpreted as saying that 80% of latency predictions will not exceed an MRE of roughly 10%, and that the manner in which that interval is constructed yields a 99% confidence that this upper bound is correct.²³ As with measures of component properties, one- and two-tail normative confidence intervals can be computed by specifying interval bounds and computing p , the probability that any particular prediction will satisfy these specified bounds.

Linear Correlation

Linear correlation is a descriptive statistic: it describes the strength of correlation between two data sets and is not directly useful for drawing inferences about future data sets. A consumer might be interested in linear correlation analysis as a descriptor of previous experimental validations of a property theory's accuracy.

We characterize that accuracy using linear correlation analysis, which allows us to assess the strength of the linearly relation between two variables—in our case, predicted and observed assembly latency. The result of such analysis is the coefficient of determination, $0 \leq R^2 \leq 1$, where 0 represents no relation, and 1 represents a perfect linear relation. In a perfect prediction model, predicted and observed latency would be identical; therefore, the goal for the model builder is a linear relation.

For λ_{ABA} , a distribution-free linear correlation was used (Spearman rank correlation). The resulting $R^2 = 0.997$ means that there is < 0.001 probability that the reported correlation could have been achieved by chance.

23. As discussed in Appendix B, this is a pessimistic interpretation of the validation data that includes a systematic error that can, with a high degree of certainty, be removed from λ_{ABA} .

6.3 Workflow for Empirical Validation

The workflow in Figure 15 expands the first two steps of the four-step validation process illustrated in Figure 13 on page 32. Figure 13's workflow is reproduced in the left portion of Figure 15; the first two steps of Figure 13 have been replaced by their expansions, resulting in a six-step workflow.

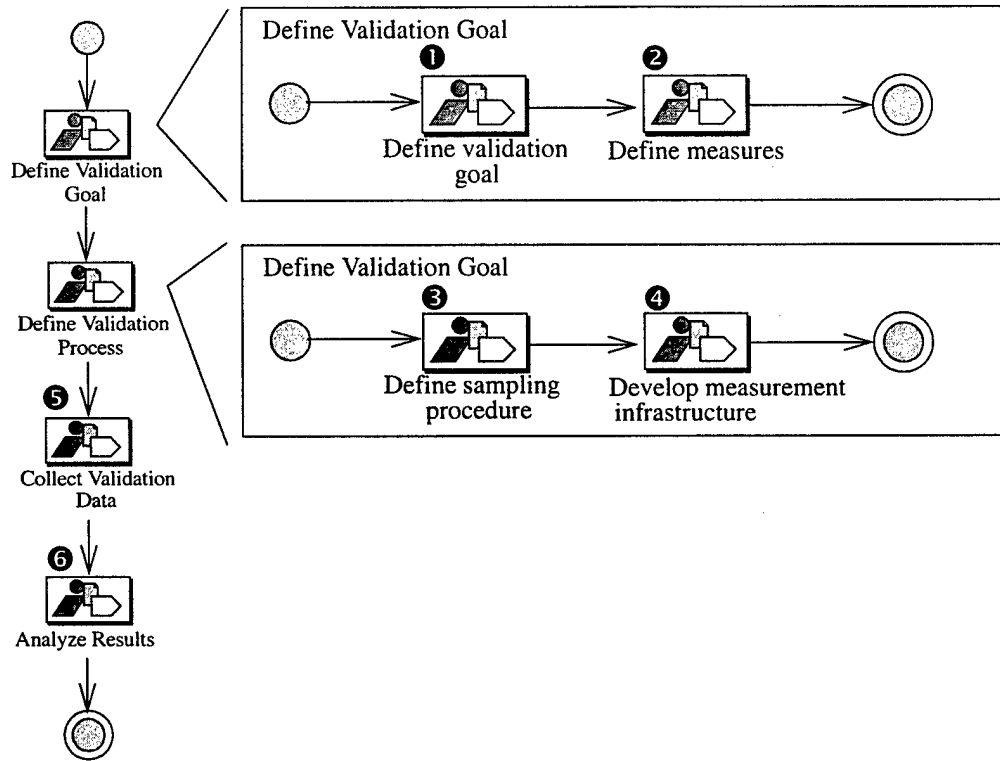

Figure 15: Expanded Workflow for Empirical Validation

In the remainder of this section, we describe the six steps shown in Figure 15.

6.3.1 Define Validation Goal

The overall objective of empirical validation is to assign a statistical label to a property theory that describes the effectiveness of that theory and to design the means of producing trusted component labels in support of that theory.

Two types of goals yielding different types of statistical labels are possible: *normative* and *informative*. Normative goals express a prediction requirement that has to be met. For example, predictions might be required to be, on average, accurate to within 0.5%. An informative goal is free of norms—it's up to the validator to describe the effectiveness of predictions. For example, the validator might compute the upper bound of a confidence interval for 60, 70, 80, and 90% of predictions, assuming varying levels of confidence.

Part of defining the validation outcome involves selecting the statistical models used for labels. As discussed in Section 6.2.2, we have used the MRE as a basis for the empirical validation of property theories and two forms of intervals for descriptive and inferential labels. Those choices are not a necessary consequence of the initial “customer” objective—rather they are choices made by the measurement specialist of the best labels for a particular validation effort. As we learn more about empirical validation, we anticipate a broadened repertoire of statistical models.

For λ_{ABA} , the design problem was to develop a controller PECT that would predict latency with an upper bound of a tolerance interval for $MRE \leq 0.05$, for a population $p = 0.80$, with a confidence level $\gamma = 0.99$. Thus, the empirical validation for λ_{ABA} was dominated by normative goals.

6.3.2 Define Measures

It is not always obvious what exactly must be measured to validate a property theory, or which measurement units are best to express those measures. Indeed, frequently there are several possible measurement units, depending on whether a direct or indirect approach is desired, or on the degree of accuracy or stability required. A good discussion of measures and measurements can be found in the seminal work of Fenton and Pleeger [Fenton 97].

From λ_{ABA} , we have identified the property of interest—latency—and defined it as the total time a task requires to perform its work. The constituents of this total time—execution time and blocking time—also had to be expressed in terms of the Pin component model and measurement units. We also had to know whether there was a technical basis for measurement at all, which, surprisingly perhaps, was not trivial.

Translating the notion of time to Pin was conceptually straightforward. Sink and source pins provided convenient “hooks” for hanging instrumentation. Each pin can be instrumented to record the moment of its activation (e.g., when a sink pin receives a request or when a source pin sends a message or makes a request), and the moment of its deactivation (e.g., when the sink pin satisfies its request or when a source pin completes its message send or has its request satisfied). These four measurement points permit a variety of time durations to be recorded on any assembly.

Defining the appropriate units of time depends on the available instruments. For λ_{ABA} , we chose to use the Microsoft high-performance clock, which records times in nanoseconds. Before making this selection, though, we had to establish that that clock could be used to measure component latency. To do so, we had to first demonstrate that the latency of a process, as recorded by the clock, was equal, within measurement tolerance, to the sum of system time and wait time for a process, as recorded by the central processing unit (CPU) clock. Once we

had established this correlation, which itself required a validation activity, we were satisfied with our defined measures.

6.3.3 Define Sampling Procedure

Defining the validation experiment eventually requires that we select a set of components and assemblies for measurement. This can be viewed as selecting components and assemblies from a population, with one important proviso: if we expect a PECT to work for all future assemblies, we must assume that not all of its components and assemblies exist. So a question arises as to how to select from a population of nonexistent entities. The three main approaches to selecting samples from a population are random, convenience, and judgment sampling.

Random sampling is useful when samples can truly be selected randomly. *Convenience sampling* occurs when the sample is taken while considering some *a priori* knowledge. *Judgment sampling* occurs when the sample is selected explicitly and sufficient domain knowledge exists to judge a sample set that represents the whole population. Of the three methods, random sampling provides the best statistical data, but it might be difficult to obtain a real random set of samples. On the other hand, convenience and judgment sampling are more practical and easier to perform, but the resulting statistical data might be biased and therefore not fully representative.

For λ_{ABA} , random sampling was used to collect latency measures from a set of synthetic components—components whose functionality consists of consuming CPU resources. We used a combination of judgment and random sampling to collect measures for assembly latency measures, and we used judgment sampling to define variation points for assemblies. Doing so created an assembly design space for constructing viable assemblies. Then, from that design space, we selected assemblies randomly. For example, in the controller PECT, no realistic assemblies have more than 50 components. Thus, that was an upper bound for one variation point in the assembly design space that we defined.

In an analytic study, we must define the design space and select a random sample from it. Our approach to validating λ_{ABA} was to exploit the “pure composition” aspects of Pin to define various dimensions of variation—the number of input and output connectors, the number of instances of each type of component, and so forth—and thereby sketch the outlines of the design space. Using these variations, we generated the pseudorandom assemblies.

We have made only tentative steps in understanding how to analytically characterize the design space and draw a random sample from it. At this point, we have only two conjectures. The first is that a component model that provides well-defined and restricted rules for allowable patterns of component interaction is likely to be better suited for statistical analysis than a wholly unconstrained component model. The second conjecture is that product line settings

may augment a component model's structure-oriented rules with rules governing semantic variation (i.e., product feature variation [Clements 02a]).

Section B.2.3 on page 98 describes the details of the sampling procedure for both components and assemblies used in the empirical validation of the controller PECT.

6.3.4 Develop Measurement Infrastructure

As with any experimental process, a measurement infrastructure must be developed to collect data. Where objective measurements are taken, as with λ_{ABA} , this infrastructure must be sufficiently well constructed to produce reliable and repeatable measurements. For λ_{ABA} , we developed a shared-memory mechanism for capturing traces of pin activation and deactivation. We also developed a distributed, trace mechanism based on the Universal Datagram Protocol (UDP) for measuring higher order SAS assemblies (i.e., an assembly of operator and controller subassemblies).

The measurement infrastructure must also be sufficiently well documented to allow the results to be repeated, possibly by disinterested third parties not associated with the original validation experiment. Just what should be documented has much to do with the property of interest. Often, it is clear which environmental factors have a direct correlation to a property, for instance, latency. Latency for a component will vary from environment to environment, based on processor speed. Other environmental characteristics could have an indirect correlation to a property—which may not be immediately obvious—for example, the compiler (or compiler flags) used to produce the component.

Describing the test environment becomes increasingly important when trying to establish causal relationships between runtime and observed behavior and is especially critical when a discrepancy exists between the predictions and observations. Trying to find a correlation between such environmental characteristics and behaviors of components and assemblies can be difficult. Altering the environment to limit or prevent unexpected behaviors is one viable approach. However, having a description about what characteristics were present during the validation may hold clues as to what was and was not considered to be possible sources of error.

For λ_{ABA} , the environmental characteristics that were recorded for the validation included platform hardware characteristics (e.g., processor, bus, and memory speed), software characteristics (e.g., operating system and compiler versions), and residual processes (e.g., those background tasks running at the time of the validation). These characteristics are discussed in Appendix B. A summary of the overall measurement and analysis infrastructure developed for λ_{ABA} is discussed in Appendix B.

6.3.5 Collect Validation Data

This step more or less speaks for itself. The only issue that requires attention is that a realistic validation experiment will generate a large volume of data and may require significant computing resources and time to do so. All generated data should be archived so that it can be subjected to historical analysis.

6.3.6 Analyze Results

As noted earlier, the primary objective of empirical validation is to assign statistical labels to components and property theories. The computation of these labels should be straightforward, given an adequate definition of goals, measures, and sampling procedures. However, this does not mean that the only utility of empirical validation is the assignment of labels. In particular, the data generated by the validation experiment can be an invaluable resource for improving the quality of the property theory.

In the case of λ_{ABA} , our evaluation goals were not satisfied when the MRE was computed for the full sample of predictions, as reported in Table 3 on page 46. Instead of an upper bound of 5% MRE, we had achieved an upper bound of only 10% (albeit with much higher confidence than required). As discussed in detail in Appendix B, analysis of the data revealed that the predictions were partitioned into two main regions: stable and accurate predictions (<5% MRE) and stable inaccurate predictions (the complement). From our experience in co-refinement and earlier spot validations, systematic error is less problematic than random error precisely because it is repeatable error. The more optimistic result shown in Table 4 can be anticipated under the assumption that the source of systematic error can be identified (as others had been during the course of co-refinement).

Table 4: (Optimistic) Distribution-Free Tolerance Interval for λ_{ABA}

Part of Interval	Description
$N = 47$ (removed systematic error)	sample size
$\gamma = 0.9907$	confidence level
$p = 0.80$	population
$\mu_{MRE} = 0.01$	MRE
UB = 4%	upper bound

Although the results in the above table are hypothetical, this hypothesis, combined with the raw data generated by the validation process, would provide useful input to a second iteration of co-refinement if it's needed.

7 Safety and Liveness Analysis in the Controller PECT

This report is focused on an empirical property theory (λ_{ABA}) and its validation. Equally vital to PECT are formal property theories. In this chapter, we illustrate the main ideas of one approach to formally verifying safety and liveness properties of components and assemblies—model checking. In that approach, a system model is extracted from component reactions and their compositions in an assembly. Safety and liveness conditions are expressed in a modal (temporal) logic and tested by an exhaustive search of the state space described by the system model.

We describe only the modeling and verification of temporal claims against a single component in the controller assembly. We defer a description of composed controller models and verifications to a follow-on report. A formal description of composition in Pin is provided by Ivers and associates [Ivers 02].

7.1 Model Checking

Model checking is a formal method for verifying finite-state concurrent systems. It is based on algorithms for system verification that operate on a system model usually expressed in some form of state-transition representation.

This system model is then checked against a set of desired properties expressed in a modal (temporal) logic. Model checking is a desirable verification approach, because it is automated and exhaustive. State-transition representations, in essence finite state machines, are intuitive to the average engineer. Temporal logics, such as computational tree logic (CTL) and linear temporal logic (LTL), are not as intuitive, but can be mastered with practice [Prior 62], [Pnueli 85]. Verification of the system is accomplished by “checking” the model—exhaustively searching the state space described by the system model and, for each state, checking whether the desired properties have been satisfied.

Characteristics of system models that favor model checking over other behavioral verification techniques include

- ongoing I/O behavior (in so-called “reactive” systems)
- concurrency (not a single flow of control)
- control intensive (minimal data manipulation)

The controller assembly has each of the above characteristics, indicating that model checking is likely to be a good fit.

The next section addresses how we apply model checking in the context of a PECT.

7.2 Process

The goal of our analysis is to determine whether the assembly of components used to implement the controller satisfies various safety and liveness properties. Therefore, we begin by producing a model of the software components used to implement the controller. In this example, we focus on the CSWI component of the SEI switch controller (see Figure 9 on page 23).

First, we build a Pin model of the CSWI component, basing the model on the implemented component, rather than its requirements. This is an important distinction; we care about what the implemented component *actually* does, not what it *should* do. Essentially, we want to ensure a strong correspondence between the model and the component implementation. Extraction of the model from the implementation is one way to accomplish this, even when performed manually, as in this example. (Alternatively, we could have built the model and generated the implementation; however, since we already had the latter, that approach was not useful.)

Next, we use a model checker to analyze the CSWI model. However, the Pin model uses a formal language—CSP [Hoare 85]—that is not understood by the model checker used in this exercise—NuSMV [Cimatti 00]. Consequently, we must define an interpretation of Pin to NuSMV. In this exercise, the interpretation is performed manually, although there is no obvious reason why it cannot be automated.

Once the CSWI model is expressed in a form that is understood by the model checker, we formalize the safety and liveness properties we want to analyze and use the model checker to determine whether the model satisfies them. Any failure that is uncovered by the tool must then be analyzed. Most failures include a counterexample—an execution trace in which the desired property is not satisfied.

A failure could mean one of three things:

1. There is an error in the CSWI component model. If the counterexample is not a possible trace of the implemented component, the formal component model must be corrected.
2. There is an error in the formalization of the safety or liveness property. If the counterexample does not violate the desired property we meant to check, the property has not been formalized correctly.
3. The model does not satisfy the property. If the counterexample is a possible trace of the implemented component and fails to satisfy the desired property, we have a real error, and the component implementation must be repaired.

Any type of failure can mean that we iterate back through the steps of this process. Modeling and analysis are often iterative processes that conclude only when a statement can be made regarding whether the component satisfies its required safety and liveness properties.

The steps of this process are elaborated in the following sections.

7.3 Building the Model

We assume that a Pin model of an assembly is available, such as the one shown in Figure 9 on page 23. As noted, the model checker we used, NuSMV, does not accept input in the formal notation used by Pin. Consequently, we translate our Pin model into a formal notation that the model checker will accept. The steps to translating the model include (corresponding to Sections 7.3.1-7.3.4, respectively)

1. Determine the scope of problem analysis.
2. Produce a Pin model of the problem.
3. Translate the Pin model into a state machine.
4. Translate the state machine into NuSMV.

These steps are elaborated in the following sections.

7.3.1 Determining the Scope of Problem Analysis

The context diagram shown in Figure 16 shows the controller assembly in Pin and highlights the region of that assembly used for our verification. The CSWI component contains the logic for interfacing to the operator and carrying out the selection and operation protocol with the XCBR component. The XCBR component controls the signals sent to the physical switch, and contains protection logic (via PIOC) and the logic needed to accept commands (i.e., select, open, and close) from the operator (via CSWI).

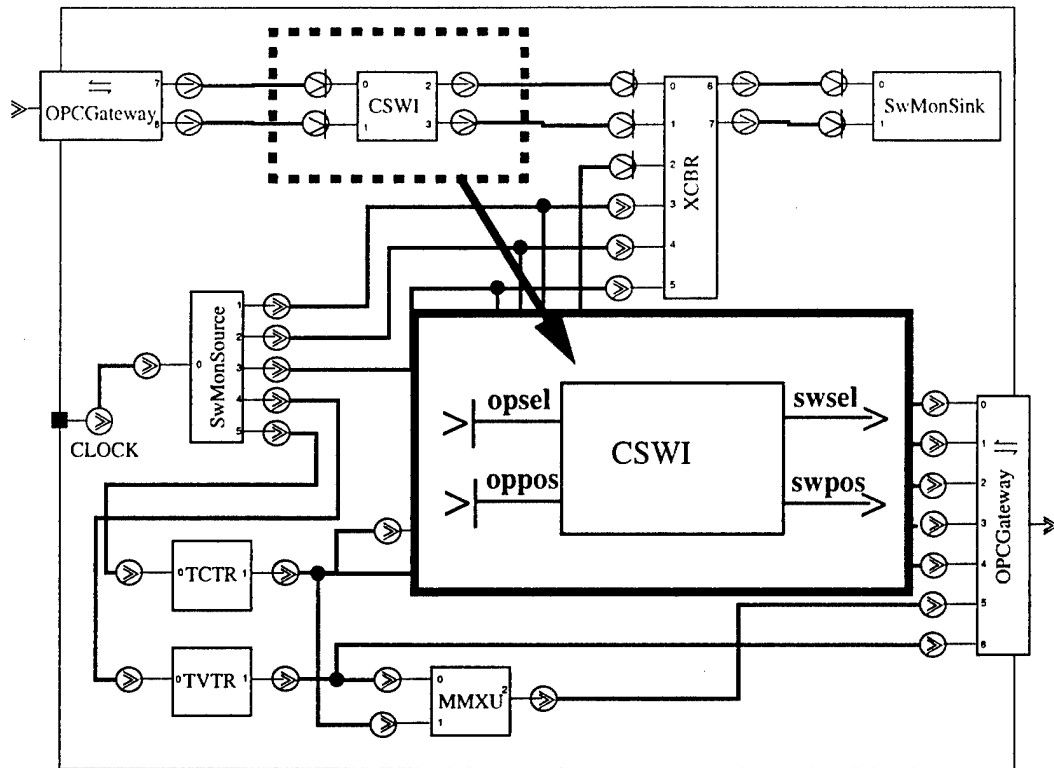

Figure 16: Controller System Diagram

As shown in Figure 16, the operator has two inputs to the controller—*opsel* and *oppos*—that indicate requests to select or position the switch. The CSWI component can send two outputs to the XCBR component—*sbsel* and *sbofos*—the effect of which is to select or position the switch. Before continuing, CSWI always waits until it receives a reply from XCBR indicating that the task has been performed. XCBR has two outputs to the physical switch where a selection or position change actually occurs—*swsel* and *swpos*. Two inputs from the physical switch—*sosel* and *sopos*—provide acknowledgement feedback to XCBR, through the respective *sbo* channels, and ultimately to the operator (perhaps in the form of indicator lights, etc.).

In this discussion, we focus on modeling the behavior of the controller assembly's CSWI component.

7.3.2 Producing a Pin Model of the Problem

CSWI has two sink pins—*opsel* and *oppos*—each of which is a synchronous mutex pin. Additionally, each sink pin is threaded, and the two sink pins are handled by the same thread. CSWI also has two synchronous source pins—*sbsel* and *sbofos*.

Because CSWI only has one thread of control, it is formally modeled in CSP as a single reaction. This specification is shown in Figure 17. Note that the leading underscore character () in event names indicates the initiation of an interaction on a pin of that name; the absence of a leading underscore indicates the completion of an interaction.

```

CSWI = _opsel.on -> _sbose1!on -> sbosel -> opsel -> Selected
      [] _opsel.off -> _sbose1!off -> sbosel -> opsel -> CWSI
Selected = _opsel.on -> _sbose1!on -> sbosel -> opsel ->
           Selected
          [] _opsel.off -> _sbose1!off -> sbosel -> opsel -> CWSI
          [] _oppos?x -> _sbopos!x -> sbopos -> _sbose1!off ->
           sbosel -> oppos -> CWSI

```

Figure 17: CSWI Pin Specification

7.3.3 Translating the Pin Model into a State Machine

While the Pin model of CSWI is based on CSP, NuSMV (our target model checker) requires input in the form of a finite state machine. As shown in Figure 18, we translated the Pin model to a simple state machine as an intermediate representation.

The transitions in that diagram correspond to CSP events in the Pin model. The names associated with these transitions, and subsequently in the NuSMV model, are based on the names of CSP events in the Pin model. For example, the Pin model defines the operator selection event as `_opsel`, with a data parameter of either `on` or `off`, written as `_opsel.on` or `_opsel.off`, respectively. To preserve traceability to event names in the Pin model, the state machine modifies this convention slightly by changing `_opsel.on` to `_opsel_on` or `_opsel.off` to `_opsel_off`. This transformation is necessitated by the syntax of NuSMV, which uses the period (`.`) operator for a different purpose. Consequently, periods (as well as exclamation points [`!`] and question marks [`?`]) were changed to underscores.

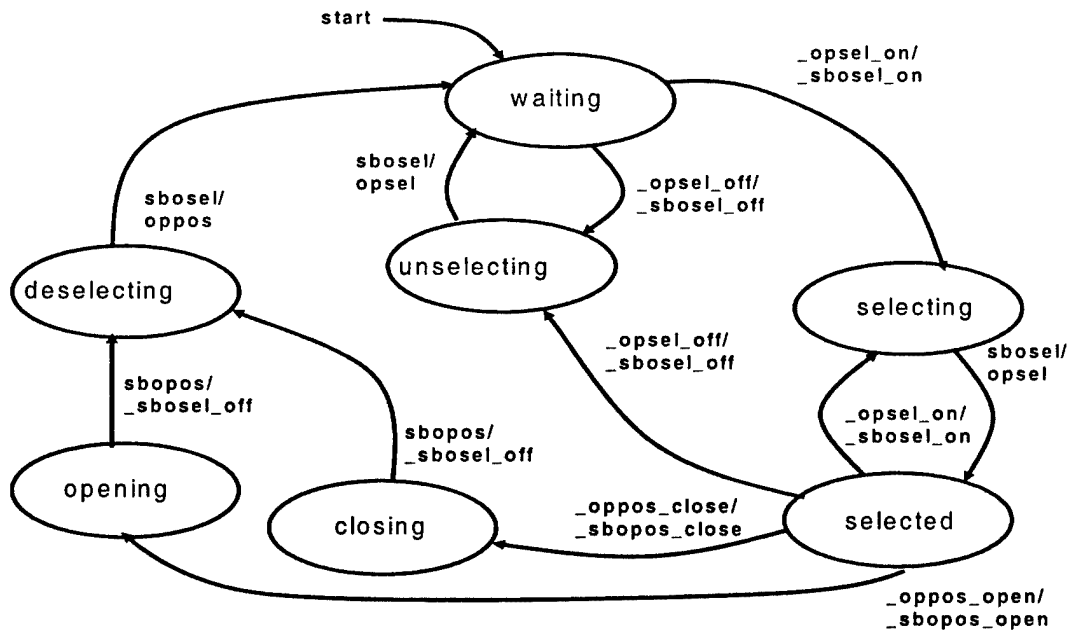

Figure 18: CSWI State Machine

Seven states compose CSWI: waiting, selecting, selected, opening, closing, deselecting, and unselecting.

The states and major transitions are described below.

- waiting state: CSWI starts in the waiting state and transitions to another state only when an `_opsel_on` or `_opsel_off` event occurs. An `_opsel_on` event, for example, indicates that the operator is selecting a switch and results in a transition to the selecting state. As part of this transition, CSWI initiates an `_sbose1_on` event. The “event1/event2” convention indicates that an occurrence of event1 not only triggers a transition, but also results in the generation of event2.²⁴ This convention is how we reflect the behavior found in the Pin reaction specification.
- selecting state: CSWI remains in the selecting state until it receives an acknowledgement that the selection has been accomplished, an `sbosel` output is received, and an `opse1` input is generated. CSWI then transitions to the selected state.
- selected state: CSWI waits in the selected state until one of the following events occurs:
 - An `_opsel_off` event is received, indicating the operator action of deselecting the switch and causing a transition to the unselecting state.
 - An `_oppos_open` event is received, indicating the operator action of requesting to open the switch and causing a transition to the opening state.

24. This follows the convention of Harel's statecharts, which are reflected in UML [Rumbaugh 00], where “event2” is called “action.”

- An `_oppos_close` event is received, indicating the operator action of requesting to close the switch and causing a transition to the closing state.
- An `_opsel_on` event is received, indicating the operator action of selecting the switch and causing a transition back to the selecting state.
- opening state: If CSWI is in the opening state and an `sbofos` output is received, CSWI transitions to the deselecting state and generates an `_sbofos_off` event to deselect the switch, since the positioning is complete. If the acknowledge is not received, the system continues to wait in the opening state.
- closing state: If CSWI is in the closing state and an `sbofos` output is received, CSWI transitions to the deselecting state and generates an `_sbofos_off` event to deselect the switch, since the positioning is complete. If the acknowledge is not received, the system continues to wait in the closing state.
- deselecting state: If CSWI is in the deselecting state and an `sbofos` output is received, CSWI transitions to the waiting state and generates an `oppos` input.
- unselecting state: If CSWI is in the unselecting state and an `sbofos` output is received, CSWI transitions to the waiting state and generates an `opsel` input.

Although they are similar, the deselecting and unselecting states are both needed; the select and operate actions require different acknowledgements to be generated, even though the transition to each is caused by the same thing—an `sbofos` output.

7.3.4 Translating the State Machine into NuSMV

This section discusses the translation of the model from the state machine represented in Figure 18 to the NuSMV textual model shown in Appendix C. It was done in a straightforward manner following the steps listed below. Note that since the Pin model indicates that CSWI has a single thread of control, there is no need to use multiple processes in the NuSMV model.

1. The transitions in the state machine (e.g., `_opsel_on` and `_oppos_open`) appear in the NuSMV model as symbolic names associated with the `input` variable, which can be assigned any of the input values shown in the state diagram. The `input` variable can also have the value “none,” indicating that no inputs currently exist. The `input` variable is declared as an IVAR,²⁵ directing NuSMV to consider all combinations of input sequences when analyzing claims.

25. IVAR is a keyword from the NuSMV tool. It's short for “input variable.”

2. The outputs in the state machine (e.g., `_sbosel_on` and `_sbopos_open`) appear in the NuSMV model as symbolic names associated with the output variable, which is declared as a VAR.²⁶ As with `input`, `output` can have the value “none,” indicating that no outputs currently exist. The output variable is changed only within the NuSMV model. The other VAR declaration is the `state` variable, which takes on the state names from the state machine (e.g., `waiting` and `selecting`).
3. There is a case expression relating the behavior of the output variable at the next state to the current values of the `state` and `input` variables. For example, the first rule states that if the current `state` is `waiting` and the current `input` is `_opsel_on`, the next value of the output is `_sbosel_on`. Hence, each output is delayed by a single tick from the condition causing it. The last rule in the case expression (`1 : none`) indicates that if none of the other rules in the case expression apply (e.g., if the `state` is `waiting` and the `input` is `_oppos_open`), the output variable will default to “none.”
4. The other case expression relates the changes in the `state` variable to the current `state` and the `input` variable. For example, if the `state` is `waiting` and the `input` is `_opsel_on`, the next `state` will become `selecting`. The last rule (`1 : state`) indicates that if none of the other rules apply, the next `state` remains equal to the current `state`.

7.4 Analyzing the Model

Once we have a model of CSWI in a form that NuSMV understands, we can apply model checking to determine whether the model (and, therefore, the component’s implementation) satisfies various system properties. For example, this type of analysis can determine whether deadlock is possible.

In this section, we begin by discussing different types of system properties that we can analyze using model checking. We then introduce temporal logic, a formal language commonly used to express system properties. Finally, we show examples of properties expressed in temporal logic that we used in analyzing the CSWI model.

7.4.1 Types of System Properties

The types of system properties evaluated by model checkers are typically classified as safety or liveness properties. Although other taxonomies have been proposed by Naumovich and Clarke [Naumovich 00], we continue to use the safety and liveness classification. Intuitively, a safety property specifies that “bad things” cannot happen, and a liveness property specifies that “good things” eventually happen [Lamport 77].

26. VAR is a keyword from the NuSMV tool. It’s short for “variable.”

To illustrate these points, consider a software application in which two or more concurrent processes must access the same critical section of code. A condition that must hold is mutual exclusion, which means that two (or more) concurrent processes cannot enter and execute a common critical section of code simultaneously. This condition can be specified as the safety property “two processes cannot be in the same critical section at the same time.” Another condition that is usually desirable in concurrent processes is starvation freedom, which means that eventually each process will enter the critical section. This can be specified as the liveness property “whenever process P1 wants to enter the critical section, it will eventually do so.”

7.4.2 Temporal Logic

Temporal logic is frequently used to formally define safety and liveness properties. Two well-known logics used in verification are LTL and CTL.

In LTL, time is viewed as a linear sequence of time instants, with each time instant having exactly one successor. The semantic intuition of LTL expressions (where **a** and **b** are primitive propositions) is as follows:

- $\Box a$
This is read as “henceforth (or always) **a**” and means that statement **a** is true now and in all future time instants.
- $\Diamond a$
This is read as “eventually **a**” and means that **a** is true either now or at some time instant in the future.
- $\circ a$
This is read as “in the next state or at the next time instant, **a** will be true.”
- $a \mathcal{U} b$
This is read as “**a** is true until **b** becomes true.”

In CTL, time is viewed as a branching tree of time instants, each with one or more possible successors. A path is a particular linear sequence of time instants (a path in the tree) in which each successive time instant is one of the possible successors of the current time instant. The semantic intuition of CTL expressions (where **p** and **q** are primitive propositions) is as follows:

- $AG p$
Along all paths, **p** holds globally (henceforth).
- $EG p$
At least one path exists where **p** holds globally.

- **AF p**
Along all paths, **p** holds at some time instant in the future (eventually).
- **EF p**
A path exists where **p** holds at some time instant in the future.
- **AX p**
Along all paths, **p** holds in the next time instant.
- **A[p U q]**
Along all paths, **p** holds until **q** holds.
- **E[p U q]**
A path exists where **p** holds until **q** holds.

Both LTL and CTL include the usual $\mathbf{a} \wedge \mathbf{b}$, $\mathbf{a} \vee \mathbf{b}$, $\neg \mathbf{a}$, $\mathbf{a} \rightarrow \mathbf{b}$ logic expressions. While LTL expressions appear to be a subset of CTL, their expressive power differs. It is possible to express properties in LTL that cannot be expressed in CTL, and vice versa. The NuSMV model checker allows claims to be expressed in either CTL or LTL; however, CTL was used as the primary specification language in this experiment.

7.4.3 CSWI Claims

The desired system properties analyzed with respect to the CSWI model include safety and liveness properties. The specific behavioral characteristics of each property are often first expressed in a natural English language format and then translated into CTL (or LTL). These temporal logic expressions are often called *claims*. Examples of claims for CSWI are discussed in the following sections.

7.4.3.1 Example Liveness Claim

A number of liveness claims were constructed for CSWI, the most obvious of which investigate its operational correctness. Those claims follow the pattern of “if an operator action occurs, a signal is conveyed to the appropriate entity.” In this example, the entity would be XCBR. A specific desired liveness property is “if the operator selects the switch, the ‘select before operate’ signal is sent to the XCBR.” Translating this into the appropriate CTL expression results in

$$\text{AG } ((\text{state} = \text{waiting}) \wedge (\text{input} = \text{_opsel_on}) \rightarrow \text{AX}(\text{output} = \text{_sbose1_on}))$$

The above claim is read as “for all paths globally, whenever CSWI is waiting and the operator select comes on, the sbo select signal will come on.”

7.4.3.2 Example Safety Claim

Safety properties are logical expressions of conditions that should never occur, presumably because the resultant action could endanger a person or harm equipment. One of the operational characteristics of the controller assembly is the enforcement of the “select before operate” protocol. This can be rephrased as the desired safety property “under human control, the switch cannot be operated unless it is first selected.” Translating this into the appropriate CTL expression results in

$$\neg E [\neg(\text{output} = \text{_sbose1_on}) U (\text{output} = \text{_sbopos_open})]$$

The above statement is read as “it is impossible for the switch to be opened (`_sbopos_open`) before it has been selected (`_sbose1_on`).”

7.4.3.3 Example Failed Claim

The CSWI model does not satisfy the following safety claim:

$$AG(\text{input} = \text{_opse1_on} \rightarrow AG \text{output} = \text{none})$$

This is actually a good thing, because we don’t want the safety claim to be true. The claim asserts that whenever the operator selects the switch, nothing will ever happen (i.e., no output will be generated). When we run this claim in NuSMV, it confirms that the model does not satisfy the claim, and it also presents a counterexample showing a particular trace in which the claim is not satisfied. The counterexample is shown in Figure 19.

```
-- specification AG (input = _opse1_on -> AG output = none)
-- is false
-- as demonstrated by the following execution sequence
State 1.1:
input = none
output = none
state = waiting
.
State 1.2:
input = _opse1_on

State 1.3:
input = _oppos_close
output = _sbose1_on
state = selecting
```

Figure 19: NuSMV Counterexample

The counterexample represents three time instants (1.1, 1.2, and 1.3), which have the following meanings:

- 1.1: CSWI begins in the initial state, waiting, and there is no input or output.
- 1.2: An input of `_opsel_on` is received, indicating that the operator selects the switch.
- 1.3: An output of `_sbose1_on` is generated, and CSWI transitions to the selecting state.

In the final time instant, 1.3, CSWI generates an output, violating the claim that nothing will happen after an operator selects the switch.

The NuSMV model and the claims verified against it are contained in Appendix C.

8 Discussion

The basic structure and concepts of a PECT had been prototyped before the SAS model problems were defined [Hissam 02]. Nonetheless, the SAS problems, although simple by the standards of production systems, were complex enough to reveal previously unappreciated, or underappreciated, subtleties of PECT. We discuss some of those subtleties, with an emphasis on those aspects of PECT that were shown to require further study. In Section 8.1, we discuss methodological results, while in Section 8.2 we briefly touch on the model solutions.

8.1 Results on Method

8.1.1 Interfaces Between Specialized Skills

One striking observation is that designing, implementing, and validating a PECT requires a combination of specialized expertise. Some indication of this can be gleaned from the different workers identified in Chapter 4. Table 5 focuses not on workers, but on their skills, and in particular those skills needed to build the SAS PECT. To some extent, these skills are coherent with the workers identified earlier. However, it is significant that we often found it necessary for a single worker to straddle several skills, suggesting, as is anticipated in the RUP, that a single person will fill many roles, perhaps simultaneously. Note that some divergence from the general set of workers and their implied skills outlined in Chapter 4 is expected, given our focus on research rather than production.

Table 5: Areas of Expertise Needed to Build SAS Operator and Controller PECTs

Area of Expertise	Use of Expertise in SAS Model Solutions
component technology	Design the Pin component model, application program interface (API), runtime environment, and deployment model.
component-based development	Implement the component technology and define and implement conformant SAS components (including their behavioral models) and their SAS assemblies.
systems programming	Implement real-time extensions to Windows 2000, observation mechanisms for validation environments, and low-level features of the component runtime environment.
measurement, validation, experimental design, statistical analysis	Define measurement scheme and statistical analysis and labeling approach for component execution time and latency property theories. Conduct component measurement and empirical validation.

Table 5: Areas of Expertise Needed to Build SAS Operator and Controller PECTs (Cont'd.)

Area of Expertise	Use of Expertise in SAS Model Solutions
performance modeling	Define the latency property theory based on the theory underlying RMA.
model checking	Develop model-checker-specific state models and define, develop, and check temporal claims of controller safety and liveness conditions.
language design and formal semantics	Design the specification language(s) for Pin assemblies and the formal (CSP) compositional semantics of connectors between component (CSP) behaviors.
electronics	Design, develop, and calibrate test hardware to simulate switch control. This custom hardware was used to empirically validate the controller latency theory.
substation automation	Define the model problems and evaluation criteria such that the PECT reflects a representative class of design and engineering problems.

As discussed in Chapter 5, co-refinement is a means by which actors possessing expertise in two domains, each with specialized conceptual schemes and vocabularies, can nonetheless negotiate mutual satisfaction of a shared concern (practicability), while ensuring satisfaction of their unique concerns (generality and tractability). Co-refinement is a negotiation process that establishes a shared conceptual interface between those actors. Note that although the interface is conceptual, it serves an analogous role to the more familiar notion of software interface: it helps to make explicit, and therefore manage, the dependencies in a system.

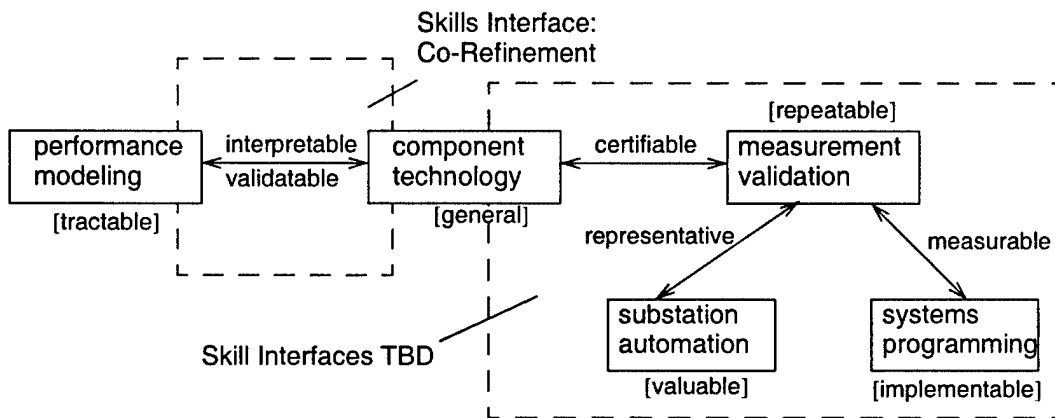

Figure 20: Interfaces Among PECT Development Skills

This metaphor of negotiation is apt and can be applied elsewhere in the PECT development process. Consider, for example, the interface between the skills depicted in Figure 20. Above or beneath each skill, we placed, in brackets ([]), a one-word descriptor for the PECT design concern that motivates the application of that skill. The associations are labeled with a one- or two-word descriptor of a *shared* concern. In Figure 20, we show a shared concern between component technology and measurement validation—“certifiable.” This concern covers issues such as whether the measured property can be validated by an independent party, whether the

measures fall within required confidence or tolerance intervals, or whether the level of systematic and random measurement error can be quantified. Measurement and validation also share a concern with the domain specialist—whether the assemblies used for empirical validation are representative of real design problems.

It is unreasonable to expect a single person to possess the range of expertise reflected in Figure 20. A transitionable PECT development method must provide a clear distribution of these forms of expertise across different workers and processes that define a separation of the skills across activities.

8.1.2 Infrastructure Complexity

Carl Sagan introduced his television series, *Cosmos*, with the statement, “*To bake an apple pie, we must first create the universe.*”

Before we can assemble components and predict their aggregate properties, we must create a PECT infrastructure that includes the collection of programs *exclusive of* application-level (e.g., controller-level) components and their assemblies. The view of PECT depicted in Figure 5 on page 13, *The Four Environments of a PECT*, is a good guide to what constitutes infrastructure. Nonetheless, that structure is guilty of oversimplification. The practicality of PECT rests, to some extent, on the cost of developing and maintaining its infrastructure. We must therefore strive to understand which part of a PECT infrastructure’s complexity is inherently related to PECT, and which part arises from concerns that have already been addressed by available technology or is inherent to a problem domain such as SAS.

One approach to obtaining this understanding is to examine Figure 5 from the perspective of a *software development environment (SDE)*. Clearly, more is required of an SDE than the assembly and analysis environments shown in Figure 5. An SDE would also include facilities for configuration and version management, and a repository of components and assemblies, for example. The components themselves will likely be implemented in a conventional programming language such as C#, C++, or Java. This suggests that code browsing, compiling, linking, and debugging facilities are also required in a PECT. Still, none of this is part of a PECT-specific infrastructure, and it is all readily available—for example, Microsoft’s Visual Studio and Borland C++’s Developer. What remains is to ensure that a PECT infrastructure is integrated with an existing SDE. While not trivial, this is not a substantial risk to PECT.

Another way to look at Figure 5, however, is from the perspective of a language-specific SDE (LS-SDE). A language comprises its syntax and semantics. In PECT, the syntax of the language is defined by the constructive model [Ivers 02]. However, the language used to specify (constructive) assemblies for any PECT is not necessarily simple in structure; its syntax and semantics are dependent on an open-ended set of environment types and analysis views, only some of which may be applicable in any given application. This added complexity must be

laid directly on the PECT doorstep—it cannot be waived off as a simple matter of SDE tooling.

Some of the infrastructure needed to support such a semantically extensible LS-SDE can be regarded as a one-time investment—once developed, a constructive model and its infrastructure can be used repeatedly for a family of applications [van Ommering 02]. This suggests that a PECT may be more easily justified in the context of a product line. Although product lines require a substantial organizational commitment, they are justified by business considerations [Clements 02a], and PECT may in fact make product lines more effective. On the other hand, there is not likely to be an infinite supply of useful constructive models. For example, Pin bears a strong resemblance to other component languages, notably Darwin [Magee 93], Wright [Allen 97], and the emerging UML V2.0 standard.²⁷ There is hope, then, for convergence on an industry-standard component language.

8.1.3 Design Space: Rules for Inclusion *and* Exclusion

We have adopted the idea of a PECT design space as a basis for validating empirical property theories—in this report, latency. The term *design space* has a metaphorical connotation, but it is given concrete meaning in empirical validation through its definition as a set of discrete *variation points*. That is, we define design space as an N-dimensional cartesian coordinate system,²⁸ where coordinates on each dimension take values from a (small) finite set representing one possible variation at that variation point, or on that dimension. From this design space, we select the sample of assemblies to use for the statistical analysis of predicted versus observed assembly behaviors.

The coordinate system for this design space defines the set of assemblies that are included within the scope of a property theory. That is, the coordinate system defines inclusion rules for assemblies. That definition reflects a positive statement of where a property theory must be valid, in the sense that any sample taken from this design space will be representative of the class of systems to which this PECT will be applied. We want the predictions to be valid for all members of this class. There is evidently a close connection between this concept of design space and that of variation points in product line architecture (e.g., Theil and Hein's work [Theil 02]), and in fact we use the term *variation point* to emphasize this connection.

In practice, however, we must also define rules for exclusion from the design space. That is, we will almost certainly want to characterize not just where we think the property theory

27. UML V2.0 is currently a work in progress. See <<http://www.uml.org/uml/>> for more information about it.

28. To be more precise, the coordinate system under discussion defines sufficient conditions for the assemblies of a class of products; the necessary conditions are defined by the constructive model and its interpretation under the property theory being validated. For example, the interpretation of the controller latency theory λ_{ABA} restricts assembly topologies to only those that satisfy the priority ceiling constraint. All assemblies must satisfy these purely syntactic, and therefore necessary, conditions.

should be valid, but also where we know it is not valid. One way to approach this is to discover the analysis limits for each variation point. The analysis limits of a variation point define the greatest lower bounds and/or the least upper bound for the set of values defined for each variation point.²⁹ More simply, each variation point can be tested to destruction to find its analysis limits. This is analogous to the approach taken by Gorton and Liu [Gorton 02]; however, their measurement object is a large-scale commercial off-the-shelf (COTS) component (an Enterprise JavaBeans server) and not the property theory used to predict performance.

In general, there has been insufficient work in software engineering research regarding the empirical validation of design theories. PECT provides a conceptual vocabulary and technical means for making much needed progress in that area.

8.1.4 Confidence Intervals for Formal Theories

If there has been insufficient work in the empirical validation of design theories based on observation (and, therefore, measurement), there has been almost no work in the empirical validation of theories based on formal logic. (Barnett and Schulte's work is an exception [Barnett 01].) Indeed, the very notions seem to be mutually exclusive, which may account for the lack of attention to this subject. Nonetheless, assertions about safety and liveness properties of assemblies (as discussed in Chapter 7) are made with respect to a model of the components' behaviors and their interactions. We can have 100% confidence that a claim is satisfied or falsified by a model. However, there are two more substantial questions:

1. Can we have objective confidence that the model corresponds to reality?
2. Can we have confidence that the model is sufficient to justify the claims?

The answer to question 1 depends, to some extent, on how the correspondence (the hypothesized "satisfies" relation) between the model and reality is established in the first place. It might be established through automated (implying formal) translation. Two forms of automated translation are possible: generating components from models (e.g., Sharygina's work [Sharygina 02]) and generating models from components (e.g., Havelund and Pressburger's work [Havelund 00]). The first form is common in practice, while the second is more of a research topic. In both cases, our confidence in the satisfaction claim is proportional, if not equal, to our confidence in the correctness of the translator implementation. This does not lead to infinite regress, however, since we have an empirical means of establishing this confidence through the testing of the translator. If, however, the correspondence between the model and component is manual, there is no basis for objective confidence in the hypothesized "satisfies"

29. We assume that the set of values for each variation point is partially ordered. This assumption seems reasonable if there is a correspondence between the variation point and some property theory parameter. Only those variation points will be of interest when testing that theory's failure.

relation. The implication is that we must use automation to generate models and/or components in our approach to PECT.

The answer to question 2 is more subtle and rests on equivalence relations over models. Asking whether a model satisfies an implementation (we now use this term in place of *reality*) is just a more specific form of the question of whether two models are equivalent for some purpose. Sometimes, but by no means always, the more concrete model is said to *refine*, or be a *refinement of*, the more abstract model; the equivalence relation is then called *refinement*. A property proven to hold for a model will also hold for its refinements.³⁰ However, there are many different ways of defining refinement. Roscoe defines a hierarchy of three forms of refinement for the CSP process algebra—trace, trace failures, and failures-divergence refinement [Roscoe 98]; Davies (citing work by Reed [Reed 88]) describes a lattice of nine refinement equivalences for CSP [Davies 93]. Not to be outdone, van Glabbeek [van Glabbeek 01] identifies 13 equivalence relations, not all based on CSP traces. In each case, different notions of equivalence can be used to justify different claims.

We can draw two inferences from the discussion of question 2. First, we should leave the definition of equivalence relations over formal models—and the theorem provers based in them—to the experts; we should apply the fruits of their efforts in PECT. Second, a PECT infrastructure must be flexible enough to accommodate a variety of formal theories, each of which provides a notion of semantic equivalence sufficient to make the kinds of specification claims required.

8.2 Results on Model Solutions

Three model problems were posed, one leading to an operator-level PECT, one to a controller-level PECT, and one to a higher order PECT for assemblies of assemblies. In the final analysis, only the operator and controller PECTs were developed. While a higher order operator/controller assembly was demonstrated, no property theory was developed for higher order assemblies.

The operator-level PECT was developed without incident. However, it became apparent during its development that the operator interface was quite simple—in fact, only reentrant sink pins were required. Moreover, operator display latency is completely dominated in any higher order assembly—the time required to interact with the display and perform data validation on operator input is minor (often less than a simple scheduling question), compared with network and controller latency.

30. This is actually too strong a statement; not all properties are preserved under refinement—deadlock freedom, for example.

Nonetheless, we developed a simple latency property theory for the operator PECT that proved to be, under the highly constrained constructive model used, highly accurate. A summary of the property theory's performance is shown in Figure 21. We do not summarize the results of this performance as a confidence or tolerance interval, since the simplicity of the PECT led us to focus our validation efforts elsewhere.

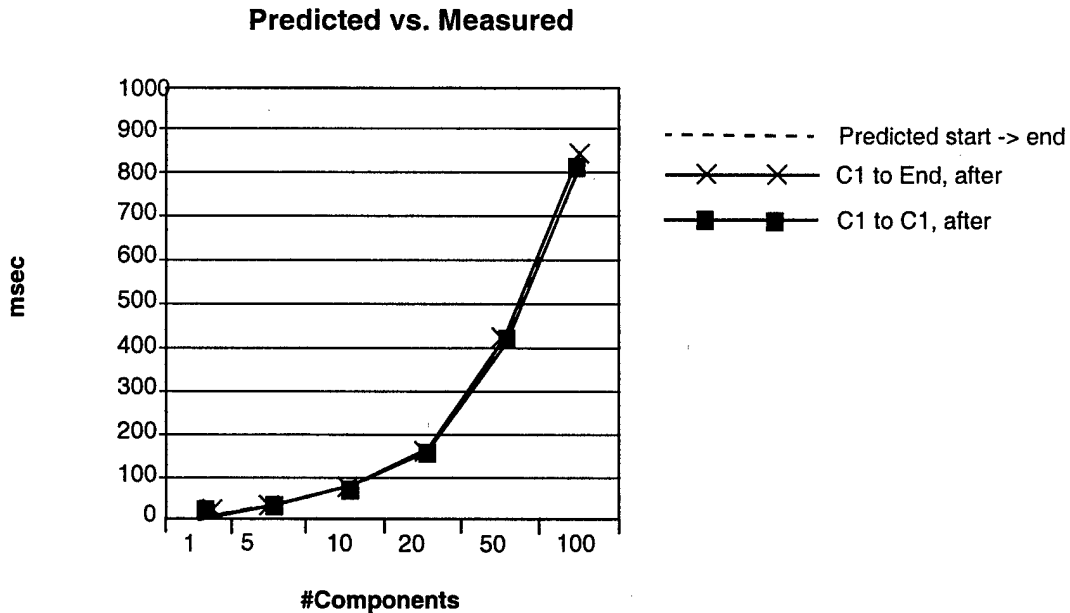

Figure 21: Results of Spot Validation of Operator PECT Latency Theory

The controller-level PECT presented considerably more methodological and technological challenges, most of which have been discussed already. To reiterate the main results, the λ_{ABA} produces stable predictions. The population as a whole has an MRE ~4%, which, in the aggregate, leads to an upper-bound 99% confidence interval in an upper bound of 10% MRE. The latter does not meet our objective of a 5% upper bound. On the other hand, such stable results are still quite good on a non-real-time platform such as Windows 2000. And, on the good assumption that, with reasonable effort, stable errors can be eliminated (where the word “error” means >5%MRE, currently exhibited by ~25% of the population—see Figure 57 on page 121), we achieve an upper bound of 4% MRE while maintaining 99% confidence.

The λ_{ABA} validation exercise was more interesting for its methodological implications than for its validation of a specific latency model. The initial validation data revealed a significant quotient of systematic and random error. Five separate validation runs were required to stabilize the model. The first three served to remove errors in the measurement infrastructure itself—the instrumentation was developed in tandem with the validation work and was therefore itself a work in progress. The last two runs served to remove inconsistencies between the model and the controller runtime implementation. In other words, the empirical validation

exposed an inconsistency between model assumption and runtime implementation; moreover, the raw data produced by the validation allowed us to quickly identify the sources of error.

It is interesting to speculate on one similarity between the development and use of empirical and formal models that this validation experience (see Appendix B on page 93) demonstrates: both processes are highly iterative. The nature of iteration with empirical models is discussed in Chapter 5 and in the validation exercise. These experiences mirror the experiences of engineers who have developed models for temporal-logic model checking. In that case, iteration is required to develop a model that can be model checked and that exposes the right level of details to satisfy a temporal claim, and to formulate the correct claims in the first place.

9 Next Steps

As noted in the introduction to this report, the objective for this work was exploration—the technical concepts of PECT and the methods for developing and validating a PECT. As with any exploration, a body of knowledge was generated that must now be consolidated. Improved understanding leads to new, and more challenging, questions that must be explored.

In this chapter, we summarize the most important areas of consolidation and exploration. Motivating these priorities is our plan to extend the work reported here during the next year to accommodate more rigorous feasibility requirements and, working with our industry partner, ABB, to incorporate feasibility requirements drawn from the domains of substation automation *and* industrial robotics.

9.1 PECT Infrastructure

The infrastructure of a PECT is only a means to an end—predictable assembly from certifiable components. However, it is a necessary means, and our ability to “scale up” the PECT approach requires some up-front investment in that infrastructure. Some of this investment has already occurred as a by-product of producing SAS model solutions and their PECTs; more needs to be done.

9.1.1 Measurement and Validation Environment

A substantial suite of tools was developed to measure component execution time, automatically generate assembly samples, interpret those assemblies to instantiate and operate on analysis views, capture traces of assembly execution, and perform statistical analysis of the timed execution traces vice their predicted traces. Most of the tools in this tool suite were used for both the operator and controller PECTs, suggesting that those tools may well form the core of a common measurement and validation environment for future PECT development.

The future work required is consolidative in nature; it involves integrating, refining, and ruggedizing the existing tool set. Integration will achieve the end-to-end automation that is required to generate the large data sets necessary to empirically validate a substantial design space. This automation will require more attention to the interfaces defined between tools and to data interchange syntax and semantics. A good foundation for data interchange has been established by using XML to externalize component assemblies, but this externalization must be made consistent with an evolving constructive model and its specification language.

9.1.2 Core Pin Language and Assembly Environment

One of the tenants of the PECT approach is that complexity can be “packaged” and hidden from end consumers. Still, there will be some minimum, irreducible complexity exposed by each analysis view. If this complexity is to be manageable in the aggregate, we must strive to eliminate as many forms of unnecessary complexity as possible. To (mis)appropriate a now famous political aphorism, “*it’s the packaging, stupid!*”

The process used in the SAS model solutions for creating and deploying assemblies of components was tedious and error prone. Component properties and assemblies of components were encoded directly in XML, and although the connector “wiring” was generated automatically from XML, there is no disguising the awkwardness of representation and process. A visual composition environment (e.g., see the work of Plakosh and associates—specifically Chapter 5 [Plakosh 99]) is a form of packaging that can dramatically simplify, and make more pleasurable, the process of attributing component behavior, and developing, analyzing, and deploying their assemblies.

As discussed in Section 8.1.2 on page 67, a (visual) PECT assembly environment is a form of LS-SDE—in this case, one that emphasizes pure composition. The future work needed in this area is a mix of exploration and consolidation, and requires a definition of a core language for the Pin component model (see the work of Ivers and associates for a start at this [Ivers 02]) and the development of a visual environment to support it (a small matter of programming). By *core*, we mean a graphical and textual syntax (including a syntax for reaction rules) and syntax-directed externalization.

9.1.3 Real-Time Component Runtime Environment

One pleasant surprise in developing the SAS model solutions was that the component runtime environments for the operator and controller were rather simple to develop. Only the controller environment posed a challenge due to the artificial circumstance of our building a priority-based real-time PECT on an operating system (Windows 2000) with very limited support for priority-based scheduling. Even so, the operator and controller component runtime environments emerged largely from a restriction of component freedom to only a limited set of environment (runtime) interfaces.

Still, for the next stage of PECT development, more care must be taken when selecting an underlying operating system and specifying the environment types for hierarchical assemblies (see Section 3.3.2 on page 17)—the latter supports distributed assemblies. A definition of these environment types will also be essential to the compositional semantics of environment-specific connectors added to the core Pin component model.

9.1.4 Model Checking (Analysis) Environments

The SAS model problems were focused primarily on theories of latency. For PECT to be successful, it must be applicable to other behavioral theories. Compositional theories of reliability for components and assemblies are also of interest to software industry. Empirical theories for compositional reliability are possible, but generalized, falsifiable theories have proven to be elusive. See the work of Mason [Mason 02] and Stafford and McGregor [Stafford 02] for an entree to this topic. Formal proofs of correctness have traditionally been thought of only as a means of obtaining reliability, not for predicting it. However, as discussed in Section 8.1.4 on page 69, there may be an empirical dimension to formal theories of correctness after all.

Complete proofs of correctness remain problematic, but within recent years, substantial progress has been made in improving the practicality of technologies for so-called *partial proofs of correctness*. In particular, proofs based on the exhaustive model checking of specific safety and liveness properties specified in a temporal logic are becoming almost mainstream. For recent developments in model checking of control systems, see Sharygina's work [Sharygina 02], for details on process algebra and model checking of concurrent Java programs, see the work of Magee and Kramer [Magee 99], and for a more theoretical perspective on the model checking, see the work of Clarke and associates [Clarke 99]. These results and those related to them are finding their way into practice. For example, Microsoft is using compositional verification to certify third-party device drivers [Ball 02].³¹ Our principle motivation for using the CSP process algebra to specify models of component behavior (i.e., reactions) is that models of assembly behavior can be composed for analysis automatically.

Our concrete next step is to develop back ends to generate lower level model representations for use in formal model checkers such as SMV³² [Cimatti 00], Failures-Divergence Refinement [Gardiner 00], and SPIN [Holzman 97], probably in that order. Although this is not trivial, it is fairly simple. More complexity is involved in the question of compositional reduction and abstraction, and other techniques to minimize the state space of composed assembly behaviors. Our approach is to defer as many of these details to the back-end analysis tool as is practical and to introduce such techniques in the Pin infrastructure only as needed.

9.2 PECT Method

This report has outlined in a broad way the processes involved in developing and validating a PECT. The general area of certification is ripe for consolidation into a PECT validation guide and further exploration into the certification locale (i.e., the environment where the certification will be done). The next steps in these areas are outlined below.

31. For more information, see <<http://research.microsoft.com/slam/>>.

32. SMV is a symbolic model-checking tool developed at Carnegie Mellon University. For more information about it, see <<http://www.cs.cmu.edu/~modelcheck/smv/smvmanual.ps>>.

9.2.1 PECT Empirical Validation Guide

How is a validation experiment constructed? How are measurements collected, and how is systematic and random error quantified? How is systematic error removed? And how is the remaining error propagated? How many samples are required to achieve the desired statistical confidence? Which form of confidence interval is most appropriate? How is the assembly population defined, and how is the sample (or frame) of that population selected? What inferences can be drawn given this sampling procedure? What statistical tools can be used to analyze unexpected results?

Most of these questions are reflected in the workflows discussed for empirical validation in Chapter 6 and illustrated in detail in Appendix B. However, our workflows are descriptive rather than prescriptive—they describe *what* steps should be performed, but do not, in most cases, specify *how*. Any prescriptions provided are quite general. As a result, the skills needed to validate a PECT are not well contained within the current method; a more prescriptive guide for laboratory validation work is a necessary consolidation effort. The objective of a prescriptive guide would be to describe the validation process and identify (if not describe) the experimental and statistical foundations necessary for conducting a sound validation. Elements of such a guide are outlined by Moreno and associates [Moreno 02], but many more elements are needed.

9.2.2 Certification Locale and Foundations for Trust

Our work so far has focused on establishing component measures in a laboratory setting. We have not yet addressed issues of how these measures can be established independently. Of equal importance to the ability of third parties to validate the predictive power of a PECT is their ability to assign trusted and objective properties to components. One aspect is the potential of insurance underwriting (e.g., see the work of Li and associates [Li 02]) as a basis for a weaker notion of trust, which we may call *confidence*. This is, however, just one aspect of a set of aspects required to establish what amounts to a social network of trust. We plan to explore them in the context of our next round of industry model problems.

Appendix A λ_{ABA} Property Theory

λ_{ABA} allows us to predict the average latency of concurrent periodic tasks on a single processor. When applied, via interpretation, to Pin assemblies, λ_{ABA} can be used to predict the average latency of arbitrary execution paths through an assembly.

Property theories are based on models. A model is a simplified representation of a real system that captures those system aspects that are relevant for gaining insight about some system property or behavior. Models can be analytic, simulation based, or a hybrid of both. An analytic model is based on mathematical relations among variables and intended to be solved mathematically. A simulation model is a computer program that reproduces, to some level of detail, the behavior of a real system. Simulation models are generally used instead of analytic models when it is impossible, or very difficult, to create an analytic model.

λ_{ABA} is a hybrid analytic-simulation model. The essential concepts of λ_{ABA} are described in Section A.2, and the simulator algorithms are discussed in Section A.3. Motivating aspects of the Pin- λ_{ABA} interpretation are also discussed in Section A.3. Section A.4 documents the syntax-directed translation scheme used to implement that interpretation.

A.1 Essential λ_{ABA} Concepts

Because the periods of tasks need not be the same, the latency of any task, sometimes referred to as a *job*, may be different due to the phasing tasks and their priorities. This effect is shown in Figure 22; in particular, notice that the start of task T2 can be delayed by higher priority tasks and that the execution time (i.e., start time to finish time) for those tasks can vary from two to three units of time.

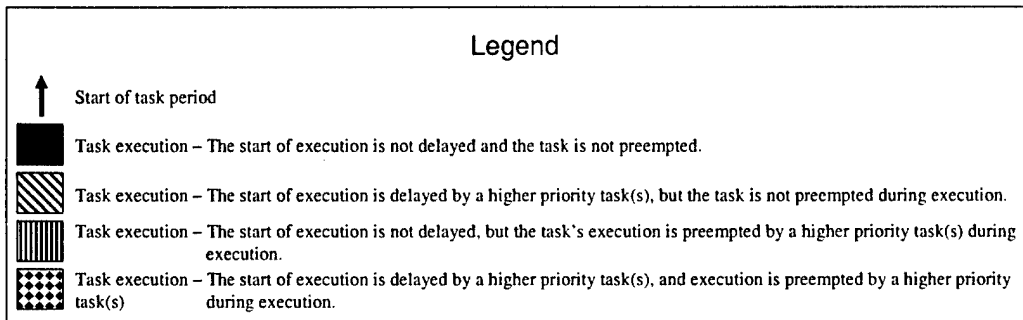
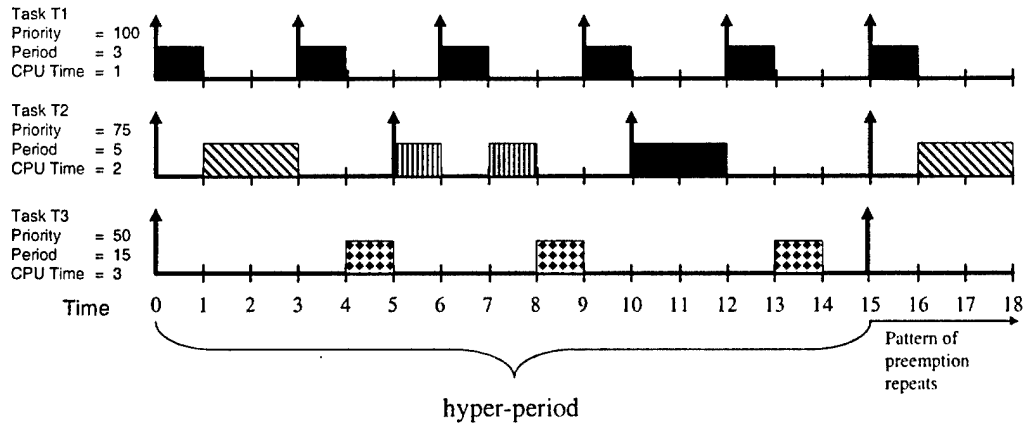

Figure 22: Task Phasing and Hyper-Period

Given N tasks T_i , we define the hyper-period³³ (HP) as the least common multiple (LCM) of the periods of all tasks. As shown in Figure 22, the hyper-period is the amount of time until the pattern of execution for a set of tasks repeats. We only need to analyze a hyper-period, because it covers all the possible latencies that a job/task will exhibit. After a hyper-period, the pattern of latencies repeats, meaning that, for each task, the number of latency predictions can be computed as follows:

$$NP = \left\lceil \frac{HP}{T_i \cdot \text{period}} \right\rceil$$

A task T_i has a property, $T_i \cdot \text{offset}$, that indicates the arrival time of the task's first job. Each task T_i consists of a sequence of subtasks, $T_i \cdot \text{subtasks}$, that perform the actual task's computation. Each subtask s_j has a priority $s_j \cdot \text{priority}$ and an execution time $s_j \cdot C$. These concepts and their relations are depicted in Figure 23.

33. Sometimes also referred to as *cycle time* in real-time literature.

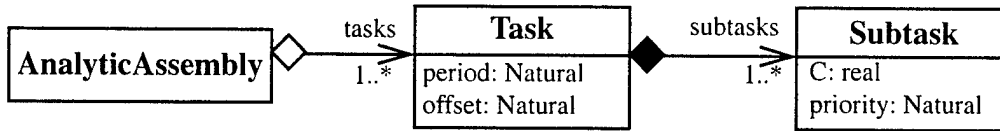

Figure 23: Elements of the λ_{ABA} Analytic Model

The following are the major assumptions of λ_{ABA} :

- A task is the only unit of concurrency.
- Each component has a unique priority.
- A task can be preempted only by a higher priority task.
- If no higher priority task is ready, a running task runs up to completion.
- Tasks do not yield the CPU until they complete a job.
- Tasks do not block on I/O.

λ_{ABA} does not address the situation where tasks can be blocked waiting on an I/O request, but it can handle blocking on a semaphore to enter a critical section. If two or more tasks share a critical section, that section is modeled as a subtask in each task. In Figure 24, the shared critical section is subtask C. Task A consists of subtasks A_1 , A_2 , C, A_4 , and A_5 ; task B consists of subtasks B_1 , C, and B_3 .

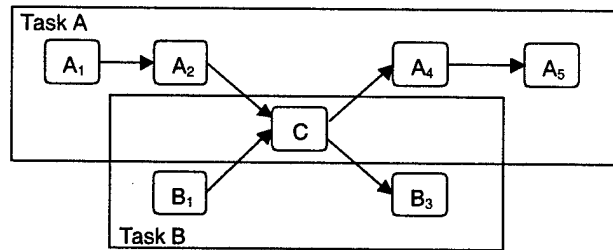

Figure 24: Blocking Example

The priority of critical section C must be assigned according to the priority ceiling protocol. That is, its priority has to be higher than the highest priority of all the subtasks immediately preceding the critical section. For example, if the priority of A_2 is 2 and the priority of B_1 is 4, the priority of C has to be at least 5.

A.2 λ_{ABA} Simulator

As explained in Chapter 5, the initial λ_* property theories were purely analytic. When we wanted to know not only how the latency of a task would be affected by blocking, but also when blocking would occur, the amount of information in the model made the formulation of a

purely analytic model quite awkward. We developed a simulation to keep track of the state of all the tasks while advancing time.

Several analytic computations are used by the simulator, thus making λ_{ABA} a hybrid analytic-simulation theory. For example, the end of the hyper-period is computed as

$$HP_{End} = \max_{i=1..N}(T_i.offset) + LCM_{i=1..N}(T_i.period)$$

Also, the arrival time of the next task at or after time t for task T_i is computed as

$$a_i(t) = \left\lceil \frac{t - T_i.offset}{T_i.period} \right\rceil (T_i.period) + T_i.offset$$

The simulation is event driven (commonly referred to as discrete-event simulation) and controlled by a main loop that advances the time from one scheduling event to the next. A scheduling event is a point in time when a task must be stopped, started, or resumed.

In each iteration of the simulation, the main loop creates a list with the next scheduling event for each task; sorts it by time, priority, and type; and then selects the one to be handled. Instead of the main loop maintaining a list of pending events, each task knows what it has to do next: start, run, or stop. Tasks are told to advance their internal clock to the time of the event being handled, and only one of them has the CPU while doing this (i.e., the task assumes it executed while advancing the clock). Figure 25 shows the pseudocode for the prediction main loop.

```

predict() {
  Initialize sleep queue to empty
  Initialize run queue to empty

  Compute the hyper-period

  Initialize all tasks and place them on the sleep queue

  Set t = to earliest task start time on the sleep queue

  while t < end of first steady-state hyper-period {
    Place all tasks on the run queue from the sleep queue
    whose starttime <= t

    if there is nothing on the run queue {
      if there is nothing on the sleep queue end while loop
      else set time to next earliest task start time on the
        sleep queue and continue while loop
    }

    Take highest priority, longest waiting task from run queue
    and execute it

    Advance t by execution time of task just executed

    if task state after execution is sleeping
      put it on the sleep queue
    else
      put task back on the run queue
  }
}

```

Figure 25: Prediction Pseudocode

The simulator uses several utility functions to initialize, determine the next scheduling event, advance the time, and finally, support report generation. Figures 26 through 28 show the pseudocode for the methods that provide these services.

```

initialize() {
  let time = 0
  let current subtask index = first subtask
  let priority = first subtask priority
  let subtask time = 0
  let task state = Sleeping
}

```

Figure 26: Initialize Pseudocode

```

float ExecuteTask() {
  if task is sleeping {
    Change state to running
    Record it's starttime
  }

  if task is running {
    let cpu time used = subtask execution time
    Advance to next subtask
    if current subtask is last subtask {
      // it has complete a job
      record job latency
      let current subtask = index to first subtask
      let task state = sleeping
      set next execution start time
    }
  }
  return (cpu time used)
}

```

Figure 27: *ExecuteTask Pseudocode*

```

Vector getJobLatencies() {
  return a vector with the recorded latencies of all jobs
}

```

Figure 28: *getJobLatencies Pseudocode*

A.3 Pin- λ_{ABA} Interpretation (Discussion)

The property theory models every assembly as a set of periodic tasks. Each task has a sequence of subtasks, which execute at specified priority levels. Hence, the analytic interpretation consists in creating this set of tasks from the constructive Pin assembly. The following discussion focuses on the highlights of the interpretation.

A.3.1 Clock Components and Task Period

To start, there is no concept of task and subtasks in Pin. Given that a task in the analytic model performs a computation periodically, it is intuitive to associate Pin clock components with tasks. A clock component is provided by an environment; it has no sink (i.e., it does not execute anything) and has a source pin that is activated periodically.

A.3.2 Restriction on Reactions

The Pin assembly shown in Figure 29 represents a task having a period of 60 milliseconds (ms), with two subtasks, c_1 and c_2 . Here, we have taken the liberty of representing a period as a parameter of a clock source pin. In the future, this will be represented using some form of annotation mechanism. For the SAS prototypes, these properties were encoded directly in an XML description of the clock interface.

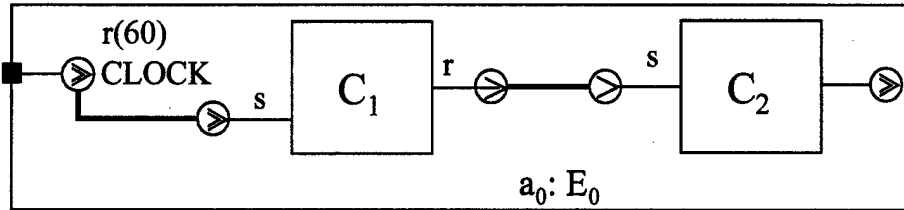

Figure 29: Simple Constructive Assembly

We impose restrictions on the form that reactions take within components. In our interpretation, sink pins will be mapped to tasks. If we allow components to have the following code structure (as reflected in the reaction specification of components), we would generate a task timeline along the lines of the one shown in Figure 30.

```

C1.s() {
  Do some computation
  Activate pin C1.r
  Do some more computation
}

```

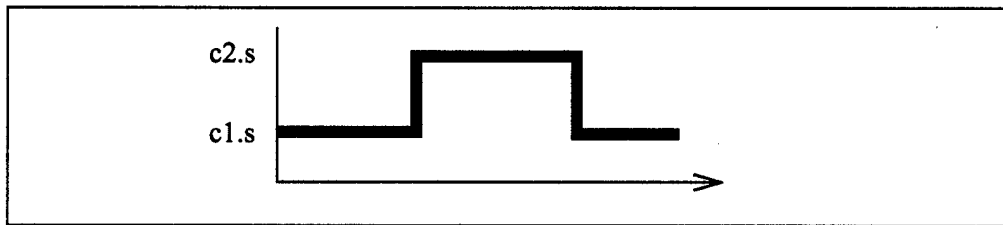

Figure 30: Timeline for a Sink Pin with Interactions in the Middle of Its Execution

This would, however, violate our analysis assumption that a subtask has to finish before its successor can start. To avoid this situation, we introduce a constructive constraint requiring that reactions occur only at the end of a sink's execution. With this constraint, the code for the previous example follows this pattern:

```
C1.s() {
  Do all some computation
  Activate pin C1.r
}
```

Its execution timeline is shown in Figure 31.

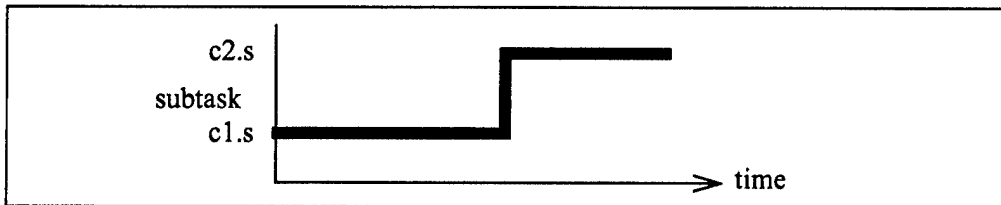

Figure 31: Timeline for a Sink Pin with Interactions at the End of Its Execution

A.3.3 Interpreting Reentrant Interactions

The sample assembly we have been analyzing so far has a linear topology, making it straightforward to get the corresponding sequence of subtasks. However, Pin allows multiple source pins to react to one sink pin and multiple sink pins to be connected to one source pin, making it possible—and perhaps the most common situation—to have assemblies with tree-like topologies. The challenge then is to linearize that tree into a sequence of subtasks that can be analyzed by the property theory.

Figure 32 shows a Pin assembly with a topology that must be flattened to make it analyzable by the λ_{ABA} property theory. In Pin, the order of interactions can be specified as being deterministic or non-deterministic (as Ivers and associates discuss [Ivers 02]). The order of interactions can be specified by annotating a Pin diagram, but in it and the following assemblies, we consider the order in Pin diagrams to be from top to bottom. So, in Figure 32, $c_1.r_1 \rightsquigarrow c_2.s$ occurs before $c_1.r_1 \rightsquigarrow c_3.s_1$. The reaction on $c_1.s$, denoted R_s in the annotation in Figure 32, determines the order of the interactions associated with $c_1.s$. So, again from Figure 32, $c_1.r_1 \rightsquigarrow c_2.s$ occurs before $c_1.r_2 \rightsquigarrow c_3.s_2$.

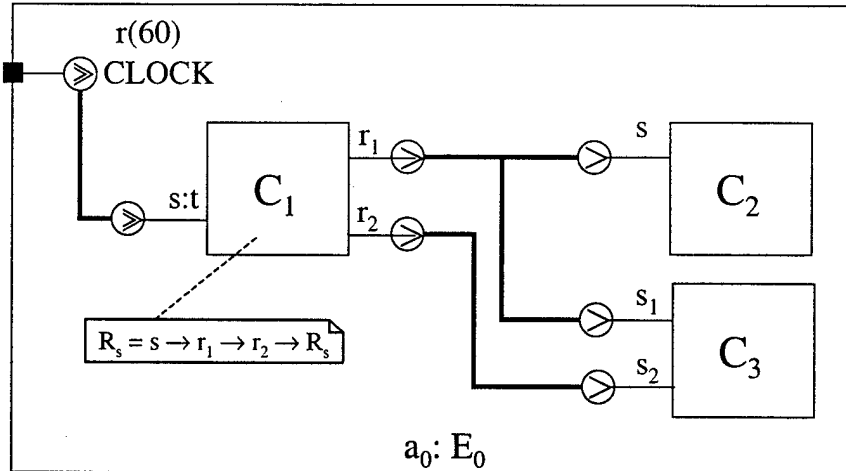

Figure 32: Constructive Assembly with Tree-Like Topology

The assembly, in Figure 32, has only one thread, which is associated with $c_1.s$. The $c_2.s$, $c_3.s_1$, and $c_3.s_2$ sinks execute in that same thread, because they are reentrant. And because threads are the units of concurrency in Windows, no problem occurs mapping the whole assembly onto one analysis task, which is the unit of concurrency in the analytic model. In this case, the fact that components $c_1.r_1 \rightsquigarrow c_2.s$ and $c_1.r_1 \rightsquigarrow c_3.s_1$ are synchronous makes it easy to figure out the order in which sinks and, consequently, subtasks will execute. The corresponding analysis task for this assembly is $\langle c_1.s, c_2.s, c_3.s_1, c_3.s_2 \rangle$, where the comma (,) is a sequence operator, and $\langle a, b \rangle$ is interpreted as *a executes before b*.

The sequence of subtasks can be obtained algorithmically by doing a pre-order traversal of the tree. Another algorithm starts from the leaves and works towards the root. Every time we get to a node where two branches are synchronously connected, we prepend the subsequence for the branch that executes first to the subsequence for the branch that executes second. For example, we obtain the subsequences $x = \langle c_2.s, c_3.s_1 \rangle$ and $y = \langle c_3.s_2 \rangle$. When we get to $c_1.s$, subsequence x is prepended to subsequence y , and then $c_1.s$ is prepended to the result, obtaining, as before, $\langle c_1.s, c_2.s, c_3.s_1, c_3.s_2 \rangle$.

A.3.4 Interpreting Asynchronous Interactions

When we introduce asynchronous connections to the assembly, we also introduce more threads, because asynchronous sink pins have associated threads. The problem that arises is that now we have many units of concurrency in the constructive model (i.e., threads), and they must somehow be mapped to tasks in the analytic model. The only way to do this is to eliminate real concurrency within the constructive assembly. We achieve this by assigning priorities to the sink pin threads so that no two sink pins have the same priority. The subassembly in Fig-

Figure 33 shows an example in which we can see how concurrency is eliminated from a subassembly with two threads via priorities.

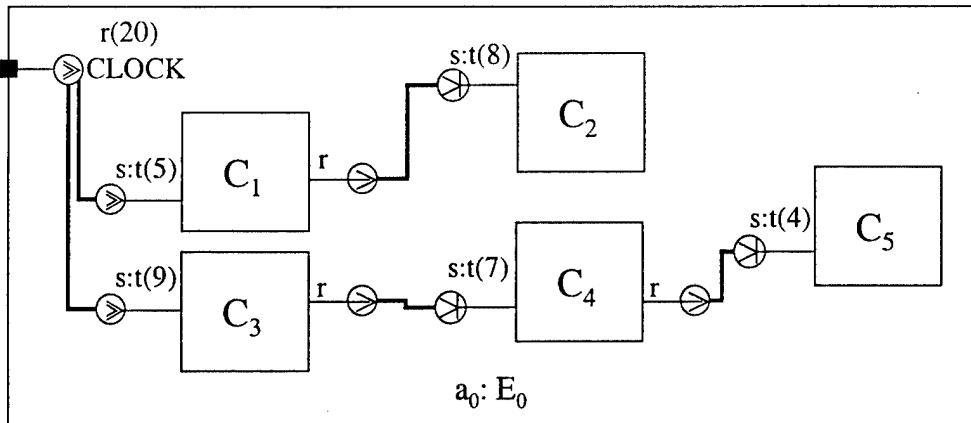

Figure 33: Constructive Assembly with Asynchronous Connections

Sink pins $c_1.s$, $c_3.s$ have threads; therefore, the top and bottom paths of execution could, in principle, run concurrently. Priorities allow us to flatten this subassembly into a sequence of subtasks.

The asynchronous calls to $c_1.s$ and $c_3.s$ are done before either of the two sink pins has a chance to execute. Pin $c_3.s$ will execute first, because it has a higher priority than $c_1.s$. Then, even though $c_1.s$ is ready to execute, $c_4.s$ will execute because it has a higher priority. When $c_4.s$ finishes, it activates $c_5.s$, but $c_1.s$ (which has a higher priority) goes first. Then $c_2.s$ executes and lastly $c_5.s$ does. The resulting analysis task is $\langle c_3.s, c_4.s, c_1.s, c_2.s, c_5.s \rangle$.

If we try to interpret this assembly by doing a pre-order traversal of the tree as we did before, we will obtain the incorrect sequence $\langle c_1.s, c_2.s, c_3.s, c_4.s, c_5.s \rangle$. Nevertheless, the right sequence of subtasks can also be obtained algorithmically. The sequence of subtasks for the two synchronous branches in the assembly can be computed by doing a pre-order traversal as we did before. In that way, we get the sequences $x = \langle c_1.s, c_2.s \rangle$ and $y = \langle c_3.s, c_4.s, c_5.s \rangle$.

When two execution paths are initiated asynchronously, we *merge* the two sequences. This merge operation consists of creating a new sequence of subtasks by appending to it the highest priority subtask from the head of the sequences being merged and repeating this step until both sequences have been consumed. Table 6 shows the state of the sequences during the merge operation in the example.

Table 6: Merge Operation Example

Clk0.subtasks	x	y
<>	<c ₁ .s, c ₂ .s>	<c ₃ .s, c ₄ .s, c ₅ .s>
<c ₃ .s>	<c ₁ .s, c ₂ .s>	<c ₄ .s, c ₅ .s>
<c ₃ .s, c ₄ .s>	<c ₁ .s, c ₂ .s>	<c ₅ .s>
<c ₃ .s, c ₄ .s, c ₁ .s>	<c ₂ .s>	<c ₅ .s>
<c ₃ .s, c ₄ .s, c ₁ .s, c ₂ .s>	<>	<c ₅ .s>
<c ₃ .s, c ₄ .s, c ₁ .s, c ₂ .s, c ₅ .s>	<>	<>

The merge operation requires only that the two subtasks in the head of the sequences being merged do not have the same priority. If they did, the algorithm would not be able to determine which one will execute first. It is important to note that, as long as the previous condition is met, different sink pins in one task can share the same priority level. For the sake of simplicity, we enforced the stronger condition that *all* threads in Pin have unique priority assignments.

A.3.5 Combining Synchronous and Asynchronous Interactions

It may seem that applying the prepend and merge operations on finding synchronous and asynchronous connections, respectively, will produce the interpretation of an assembly with mixed synchronous and asynchronous connections. In fact, in the example used to present asynchronous connections, there were also synchronous connections down the branches. However, this strategy will not render the right analytic interpretation if synchronous connections are followed (from root to leaves) by asynchronous connections, as is the case in the subassembly shown in Figure 34.

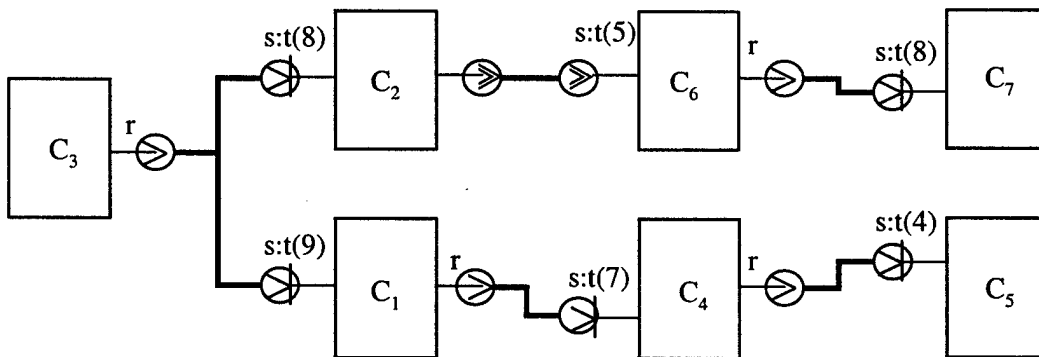

Figure 34: Mixed Synchronous and Asynchronous Connections

The correct interpretation of this subassembly is <c₂.s, c₁.s, c₄.s, c₆.s, c₇.s, c₅.s>. If we work from the leaves toward the root applying the prepend and merge operations, we get the

sequences $x = \langle c_{2.s}, c_{6.s}, c_{7.s} \rangle$ and $y = \langle c_{1.s}, c_{4.s}, c_{5.s} \rangle$. However, if we apply the prepend operation as suggested for the earlier interpretations (see Section A.3.3), we would get the wrong sequence $\langle c_{2.s}, c_{6.s}, c_{7.s}, c_{1.s}, c_{4.s}, c_{5.s} \rangle$.

The problem is that the asynchronous interaction activates another thread, allowing more than one component to be ready simultaneously. This means that when the two sequences are combined, the algorithm should determine which ready component will execute, based on the algorithm's priorities. However, this has to be done after the asynchronous interaction. This operation, called *combine*, requires that when a subtask is added to a sequence, whether it was activated asynchronously is indicated using an overbar ($\bar{}$) over the asynchronous sink pin's name, for example, $\langle c_{6.\bar{s}}, c_{7.s} \rangle$. The operation behaves as a prepend as long as no asynchronously activated subtasks are in the head of either sequence. When one is, the operation behaves as a merge from that point on. Table 7 shows the steps in the combine operation for the example.

Table 7: *Combine Operation Example*

C0.subsequence	Sequence0	Sequence1	Mode
$\langle \rangle$	$\langle c_{2.s}, c_{6.\bar{s}}, c_{7.s} \rangle$	$\langle c_{1.s}, c_{4.s}, c_{5.s} \rangle$	prepend
$\langle c_{2.s} \rangle$	$\langle c_{6.\bar{s}}, c_{7.s} \rangle$	$\langle c_{1.s}, c_{4.s}, c_{5.s} \rangle$	merge
$\langle c_{2.s}, c_{1.s} \rangle$	$\langle c_{6.\bar{s}}, c_{7.s} \rangle$	$\langle c_{4.s}, c_{5.s} \rangle$	merge
$\langle c_{2.s}, c_{1.s}, c_{4.s} \rangle$	$\langle c_{6.\bar{s}}, c_{7.s} \rangle$	$\langle c_{5.s} \rangle$	merge
$\langle c_{2.s}, c_{1.s}, c_{4.s}, c_{6.\bar{s}} \rangle$	$\langle c_{7.s} \rangle$	$\langle c_{5.s} \rangle$	merge
$\langle c_{2.s}, c_{1.s}, c_{4.s}, c_{6.\bar{s}}, c_{7.s} \rangle$	$\langle \rangle$	$\langle c_{5.s} \rangle$	merge
$\langle c_{2.s}, c_{1.s}, c_{4.s}, c_{6.\bar{s}}, c_{7.s}, c_{5.s} \rangle$	$\langle \rangle$	$\langle \rangle$	merge

A.3.6 Multiple Asynchronous Interactions on One Source Pin

When two sink pins are connected to an asynchronous source, the merge operation assumes that they are activated at the same time. In practice, this is not true; they are activated in the order specified in the assembly. A problem arises if one of the activated sinks has a priority greater than that of the activating source, because the source will be preempted before it finishes activating the remaining sinks. When that happens, the actual behavior may not be what the merge operation predicts.

Figure 35 depicts an assembly with this problem. The interpretation just described renders the incorrect sequence $\langle c_{1.s}, c_{4.s}, c_{2.s}, c_{6.s}, c_{5.s} \rangle$ when the actual behavior is $\langle c_{2.s}, c_{6.s}, c_{1.s}, c_{4.s}, c_{5.s} \rangle$. The actual behavior differs because the sink $c_{2.s}$ preempts the thread on the reaction (source) $c_{3.r}$ before it activates pin $c_{1.s}$.

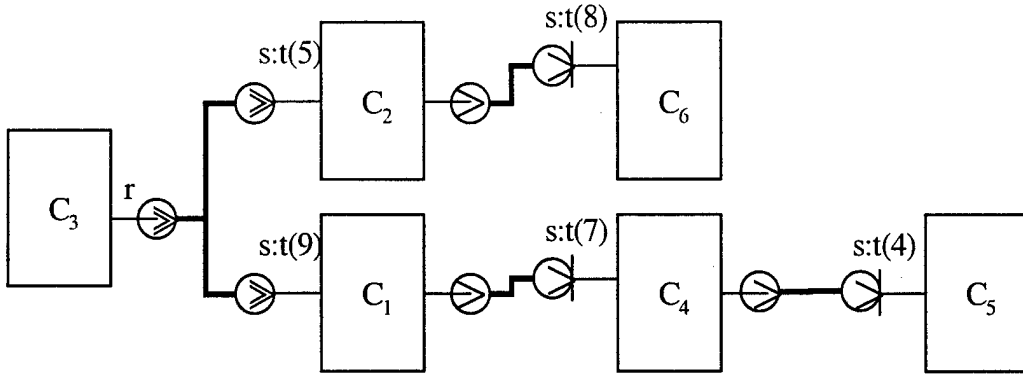

Figure 35: Multiple Asynchronous Connections Problem

We can remove this problem by applying a rewrite rule on the constructive assembly before interpreting it. This preprocessing consists of rewriting all the asynchronous connections by interposing a proxy component between each source and the asynchronous connector. This proxy has a reentrant (and therefore unthreaded) sink that is connected synchronously to the source of the original asynchronous connection and a source that is connected to the original asynchronous connector. The proxy component has no execution time, and because it is unthreaded, it executes at the same priority as its caller. Figure 36 shows this rewrite rule applied to the assembly in Figure 35.

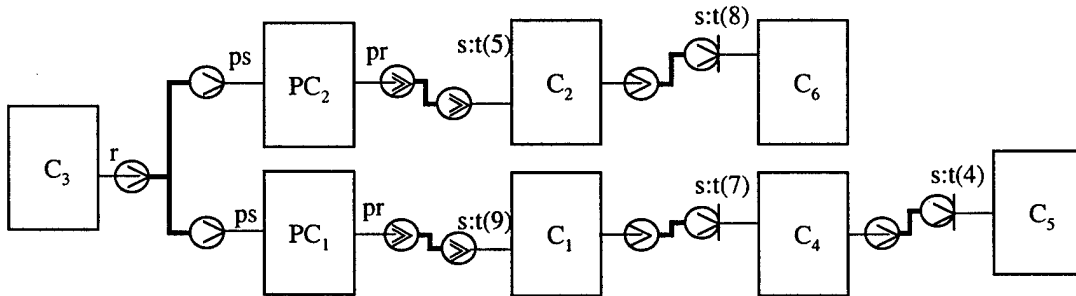

Figure 36: Multiple Asynchronous Connections Rewrite

After preprocessing, the interpretation renders $\langle pc_2.ps, c_2.s, c_6.s, pc_1.ps, c_1.s, c_4.s, c_5.s \rangle$. The proxy components pc_n have no execution time, so they can be removed from the sequence. Finally, we obtain the right execution sequence $\langle c_2.s, c_6.s, c_1.s, c_4.s, c_5.s \rangle$.

A.4 Pin- λ_{ABA} Interpretation (Formal)

The discussion so far has been informal. To enable automated interpretation, we must complete the formalization. We chose to use syntax-directed translation to implement the interpre-

tation [Aho 87]. This requires an input grammar for the constructive assembly and a set of semantic reductions that render the interpretation.

The grammar for constructive assemblies is as follows:

```
asm → src | asm & src
src → pin * subasm_set | pin + subasm_set
pin → component.pinId
subasm_set → subasm | ( subasm_list )
subasm_list → subasm | subasm_list , subasm
subasm → snk | snk - src_set
snk → pin
src_set → src | ( src_list )
src_list → src | src_list , src
```

where an asterisk (*) denotes asynchronous interaction, a plus sign (+) denotes synchronous interaction, a dash (-) denotes reaction, and a comma (,) separates source pins in a reaction and sink pins in a 1:N interaction. Note that reactions are not expressed in CSP, but rather only in the restricted form of call dependency.

Notes:

- The interpretation assumes that all λ_{ABA} constructive constraints are honored. That is why we make no distinction in this language for mutex sink pins—their blocking effect is addressed by the constructive constraint for the priority ceiling.
- To make the grammar simpler, we have disregarded the fact that the *src* sources in the first production have to be different, because their pins must have an implicit periodic stimulus. This is the case for the Clock component.

The syntax-directed definition for obtaining the analytic assembly for a constructive assembly is shown in the following table. Both synthesized and inherited attributes are used. The pseudocode for the types and functions used in the syntax-directed translation are shown in Sections A.4.7 and A.4.8.

To keep the syntax-directed definition presented here as simple as possible, some liberties have been taken. The *src.period* and *pin.priority* attributes are used without first being assigned anywhere. Assigning them would have required adding a declaration construct to the grammar and a symbol table to the syntax-directed definition. Also, the *src.period* attribute should have been synthesized from the *pin.period* attribute, which isn't expressed in the semantic rules either.

Table 8: Syntax-Directed Definition for the Analytic Interpretation

Production	Semantic Rules
asm $\hat{A}E$ src	addtask(src.period, src.subtasks) src.priority := 0
asm $\hat{A}E$ asm & src	addtask(src.period, src.subtasks) src.priority := 0
src $\hat{A}E$ pin * subasm_set	src.subtasks := combine(subasm_set.stseq) subasm_set.priority := src.priority subasm_set.mode := async
src $\hat{A}E$ pin + subasm_set	src.subtasks := combine (subasm_set.stseq) subasm_set.priority := src.priority subasm_set.mode := sync
pin $\hat{A}E$ component . pinId	pin.name := component.lexicalvalue() + pinId.lexicalvalue()
Subasm_set $\hat{A}E$ (subasm_list)	subasm_set.stseq := subasm_list.stseq subasm_list.priority := subasm_set.priority subasm_list.mode := subasm_set.mode
Subasm_list $\hat{A}E$ subasm	subasm_list.stseq := seqadd(null, subasm.subtasks) subasm.priority := subasm_list.priority subasm.mode := subasm_list.mode
subasm_list $\hat{A}E$ subasm_list1 , subasm	subasm_list.stseq := seqadd(subasm_list1.stseq, sub- asm.subtasks) subasm.priority := subasm_list.priority subasm.mode := subasm_list.mode
Subasm $\hat{A}E$ snk	snk.epriority := getpriority(subasm.priority, snk.priority) subasm.subtasks := prependsubtask(null, snk.name, snk.epriority, subasm.mode)
Subasm $\hat{A}E$ snk - src_set	snk.epriority := getpriority(subasm.priority, snk.priority) src_set.priority := snk.epriority subasm.subtasks := prependsubtask(src_set.subtasks, snk.name, snk.epriority, subasm.mode)
snk $\hat{A}E$ pin	snk.priority := pin.priority snk.name := pin.name
src_set $\hat{A}E$ (src_list)	src_set.subtasks := src_list.subtasks src_list.priority := src_set.priority
src_list $\hat{A}E$ src	src_list.subtasks := src.subtasks src.priority := src_list.priority
src_list $\hat{A}E$ src_list1 , src	src_list.subtasks := prependseq(src_list1.subtasks, src.subtasks) src.priority := src_list.priority

A.4.7 Types

```
// type definitions
t_seq : sequence of subtasks
t_stseq : sequence of sequences of subtasks
t_mode: mode of activation of a sink: sync, async
```

A.4.8 Functions

```
addtask(int period, t_seq subtasks) {
  adds a periodic task with the specified period and subtasks to the
  analytic assembly
}

t_seq seqadd(t_stseq a, t_seq b) {
  t_seq r
  r := a + <b>
  return r
}

t_seq prependseq(t_seq a, t_seq b) {
  t_seq r := a
  r := r + b
  return r
}

t_seq prependsubtask(t_seq a, char name, int priority, t_mode mode) {
  t_subtask st
  st.name := name
  st.priority := priority
  st.mode = mode
  t_seq b = <st> + a
  return b
}

t_seq combine(t_stseq a) {
  t_seq b := <>
  for each t_seq c in a {
    t_seq t := b
    // combine t and c into b
    b := <>
    while t.size > 0 && first(t).mode = sync {
      b := b + <first(t)>
      t := tail(t)
    }
    while t.size > 0 && c.size > 0 {
      if first(c).priority > first(t).priority {
        b := b + <first(c)>
        c := tail(c)
      } else {
        b := b + <first(t)>
        t := tail(t)
      }
    }
  }
  if t.size > 0 {
    b := b + t
  } else {
    b := b + c
  }
  }
  return b
}
```

Appendix B λ_{ABA} Empirical Validation

B.1 Introduction

Validation for the controller PECT consists of empirically quantifying the accuracy and confidence of the predictions based on λ_{ABA} . This quantification is done by statistically comparing predictions with actual measurements of assembly properties and establishing confidence in the results, which, in turn, increases confidence in the analysis model.

This appendix describes in detail the experiment to empirically validate λ_{ABA} .

B.2 Empirical Validation

Sections B.2.1 - B.2.6 correspond to steps 1 - 6 in Figure 15 on page 47.

B.2.1 Define Validation Goal

The goal for the controller PECT is that the latency for a job within the hyper-period can be predicted with an $MRE \leq 0.05$ (5%) with a confidence level $\gamma = 0.99$ (99%). A minimum acceptable $p = 0.80$ (80%) was established for a pass/fail condition. Latency is defined as the average latency of each job in each period of the assembly hyper-period.

B.2.2 Define Measures

B.2.2.1 Time and Pins

Which time is measured and how is fundamental to this empirical validation, the controller PECT, and λ_{ABA} . Although the specific *measure* for time differs between the property for components (Section B.2.2.2) and assemblies (Section B.2.2.3), the *units* of time are the same, and the same apparatus is used.

The measurement infrastructure put into place is hosted on a Microsoft Windows platform and is conformant to the VenturCOM RTX clock counter, which has a resolution on the order of $< 1\mu s$.³⁴ Time recorded by the measurement infrastructure using this clock counter is in milliseconds (ms) with eight digits of precision.

A time-stamped event is generated when a pin is entered (activated) or exited (deactivated). When such an event is generated, the measurement infrastructure reads the clock counter's value and records it with the event. Doing so provides two pieces of information—a time-ordered sequence of pin events and a means of determining the time interval between any two events.

B.2.2.2 Component Execution Time

When a pin (source or sink) is entered, it is considered *activated*. Activation occurs when

- sink pin *enter* event. The component is in receipt of a message or request (stimulus). This is the start of a reaction.
- source pin *enter* event. The component is making a request or sending a message (response). This is the start of an interaction.

When a pin (source or sink) is exited, it is considered *deactivated*. Deactivation occurs after a

- sink pin *leave* event. The component has satisfied the request. This is the end of a reaction.
- source pin *leave* event. The component has completed making the request or sending the message. This is the end of an interaction.

The above time-recorded events define measurement points when measuring individual components or an assembly of components. For example, consider the component shown in Figure 37.

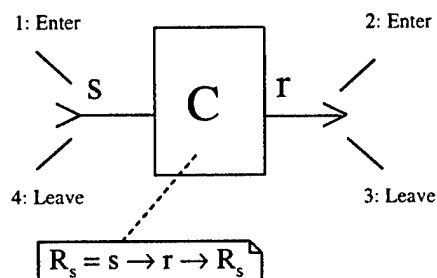

Figure 37: Pin Component Enter and Leave Events

The reaction rule for this simple component could be expanded from that illustrated in Figure 37 to show the specific enter and leave events as $R_s = s \rightarrow r \rightarrow \bar{r} \rightarrow \bar{s} \rightarrow R_s$, where \bar{x} represents the specific leave event for a given sink or source pin. Figure 38 illustrates six time measurements on a component based on enter and leave events for sink and source pins.

34. RtGetClockTime() reports time in 100 nanosecond units.

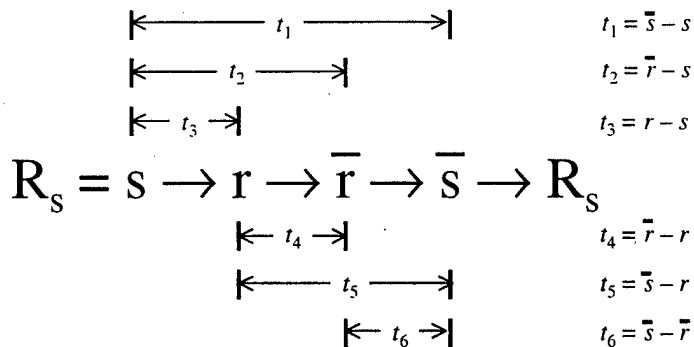

Figure 38: Time Measurements on Component Sink and Source Reactions

When two or more components are assembled, the number of possible measurement points (due to the increase in events generated by additional components) allows additional calculations to be made across component interactions.

For λ_{ABA} , the total execution time of reactions is of interest—specifically, t_1 , where $t_4 = 0$ for all source pins in the reaction (see Figure 39).

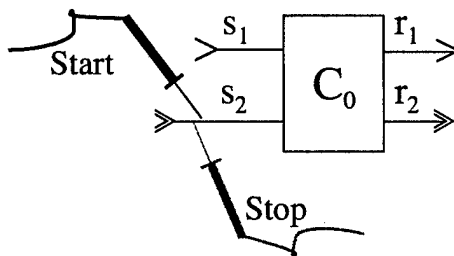

Figure 39: Measuring the Execution Time of a Pin Component

B.2.2.3 Assembly Latency

An interaction between components exists when the source pin of one component is connected to the sink pin of another. Further, interactions between components can continue as a

- linear interaction (as shown in Figure 40)
- multilinear interaction (as shown in Figure 41)
- one-to-many interaction (as shown in Figure 42)
- many-to-one interaction (as shown in Figure 43)
- many-to-many interaction (as shown in Figure 44)

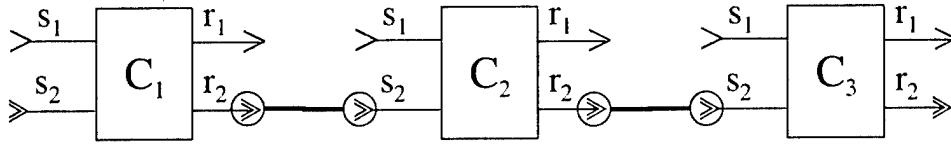

Figure 40: A Simple Linear Interaction

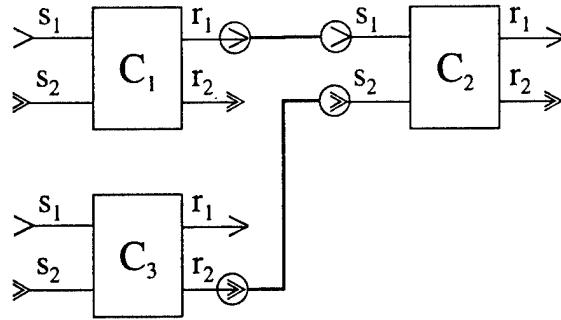

Figure 41: A Simple Multilinear Interaction

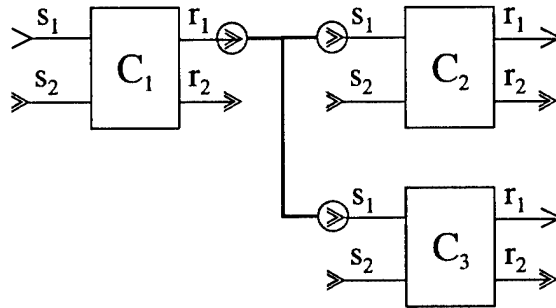

Figure 42: A Simple One-to-Many Interaction

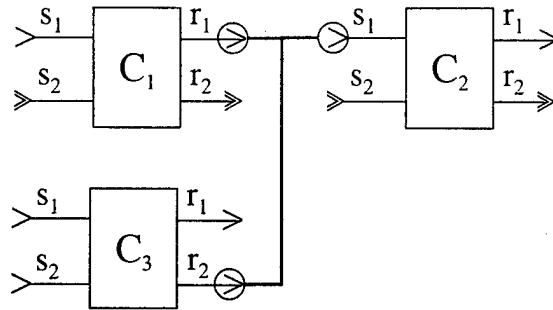

Figure 43: A Simple Many-to-One Interaction

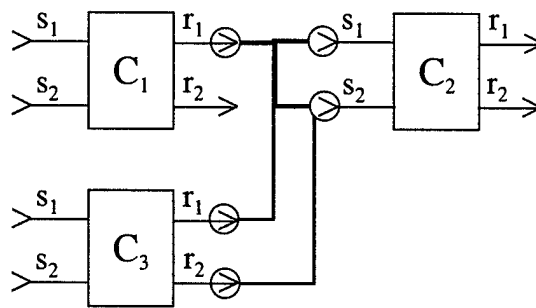

Figure 44: A Simple Many-to-Many Interaction

An assembly is a set of one or more interactions. A task is defined as the set of interactions starting with one component's source pin and terminating at another component's sink (or source) pin. Consider the small assembly depicted in Figure 40. The set of interactions from $c_1.r_2 \rightsquigarrow c_3.s_2$ (i.e., $\{c_1.r_2 \rightsquigarrow c_2.s_2, c_2.r_2 \rightsquigarrow c_3.s_2\}$) is considered a task. A job is the scheduled periodic execution of a task; a task has one or more jobs in a hyper-period. For λ_{ABA} , latency for any job in any period is of interest.

Latency for a job is measured from the time the first source pin is activated ($c_1.r_2$ from Figure 40) to the time the last sink pin is deactivated ($c_3.s_2$), as illustrated in Figure 45.

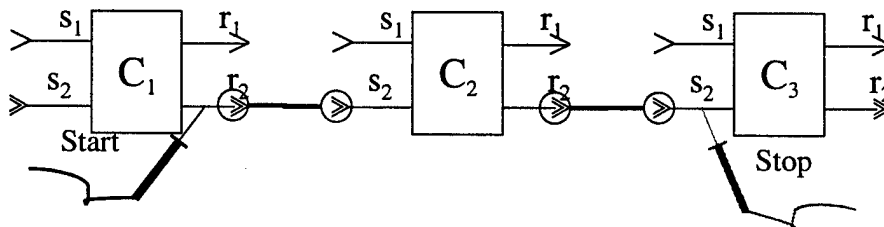

Figure 45: Measuring the Latency for a Simple Assembly

B.2.3 Define Sampling Procedure

The overall process for validating λ_{ABA} was to

1. Predict the latency of the longest path jobs in a sample of assemblies.
2. Measure the actual latencies of those jobs.
3. Compare predicted and actual latencies.

To perform the steps above, we needed the following:

1. a population of components (with measured execution times)
2. a representation population and sufficient quantity of assemblies built from those components

The components and their assemblies did not exist—a situation that may arise frequently in the early stages of PECT development. Thus, we were forced to develop synthetic components and assemblies.

B.2.3.1 Component Sample

To create a viable population of components to choose from, 15 classes of synthetic components were created. The differentiation between each class was strictly controlled—specifically execution time. The classes were named sequentially from synthetic5 through synthetic20, where the numerical postfix indicated the number of milliseconds for which the component was designed to execute. The calculation that was performed by this synthetic component is shown in Figure 46.

```
Line. 1 for (int i = INT_MIN / 765000; i < 0; i++) {  
Line. 2   for (int j = 0; j < execution; j++) {  
Line. 3     double t = sqrt(abs(i)) * sqrt(abs(j));  
Line. 4   }  
}
```

Figure 46: Execution Calculation Made by the Synthetic Component

The variable `execution` in Line 2 of Figure 46 is initialized for all instances for each class to a value that approximates the desired execution delay (e.g., `execution = 5ms.` for synthetic5 and `6ms.` for synthetic6).

The interface and reaction rules for each synthetic component was identical. Each synthetic component had one synchronous (s_1) and one asynchronous (s_2) sink pin, as well as one synchronous (r_1) and one asynchronous (r_2) source pin. The interface for each pin (named signal) was identical, taking no `in` or `in/out` arguments and having no return value, which is equiv-

alent to the C-language specification `void signal (void)`. The asynchronous sink pin (s_2) was handled by one thread. Finally, the reaction rules for the synthetic component were $RS1 = s_1 \rightarrow r_1 \rightarrow \bar{r}_1 \rightarrow r_2 \rightarrow \bar{r}_2 \rightarrow \bar{s}_1 \rightarrow RS1$ and $RS2 = s_2 \rightarrow r_2 \rightarrow \bar{r}_2 \rightarrow r_1 \rightarrow \bar{r}_1 \rightarrow \bar{s}_2 \rightarrow RS2$. The reaction rule for either sink pin would be fired only after the internal calculation in Figure 46 was performed.

The execution time (in milliseconds) for each reaction was measured to a 95% confidence interval. The number of samples was chosen to achieve that target precision. In most cases, that precision was achieved before 30 samples. For each reaction, the average execution time and standard deviation were recorded.

In addition to synthetic components, the environment Clock component was developed. This component is used to periodically generate a signal on a source pin for a specific period (e.g., every 200ms). The period can be configured prior to the execution of any instance of that class, and the signal can be generated on either a synchronous or asynchronous source pin.

For the validation of λ_{ABA} , it was only necessary to measure the execution time of synthetic components. The Clock component has no "internal" calculation and is used as the stimulus for various jobs within the assembly. The remainder of this section discusses the procedure for measuring synthetic components.

The steps for sampling the execution time of the synthetic component are

1. Create a test Pin component assembly for each synthetic component to be measured.
2. Execute each synthetic component through the runtime environment and capture its measured execution time.
3. Update the Pin component description (registry) for each component tested with the captured measures from the runtime environment.

Each step is described in detail below.

Step 1: Create a test Pin component assembly for each synthetic component to be measured.

This step is done using a series of MS-DOS batch (.BAT) files. The `createsinktest.bat` script is used to generate a component description for each synthetic component class having an approximate designed execution time of 5ms (i.e., `synthetic5`) to 20ms (i.e., `synthetic20`). That script calls the `createonesinktest.bat` script to generate a single component description for the synthetic component enumerated as a parameter. The output from this initial step is a sequence of synthetic component classes, each with its own unique execution time in the general form shown in Figure 47.

```

Line. 1 <?xml version="1.0" ?>
Line. 2 <Assembly xmlns="PinTekXML.xsd">
Line. 3   <Components>
Line. 4     <Component name="clock1" type="clock">
Line. 5       <Property propId="measurement" value="true" />
Line. 6       <Property propId="period" value="100" />
Line. 7     </Component>
Line. 8     <Component name="task1" type="synthetic5">
Line. 9       <Property propId="measurement" value="true" />
Line. 10      <Property propId="priority" value="10" />
Line. 11      <Property propId="loadFactor" value="5" />
Line. 12    </Component>
Line. 13    <Component name="task2" type="syntheticN">
Line. 14      <Property propId="measurement" value="true" />
Line. 15      <Property propId="priority" value="15" />
Line. 16      <Property propId="loadFactor" value="N" />
Line. 17    </Component>
Line. 18  </Components>
Line. 19  <Connectors>
Line. 20    <Connector>
Line. 21      <Source component="clock1" pin="0" />
Line. 22      <Sink component="task1" pin="1" />
Line. 23    </Connector>
Line. 24    <Connector>
Line. 25      <Source component="task1" pin="2" />
Line. 26      <Sink component="task2" pin="0" />
Line. 27    </Connector>
Line. 28    <Connector>
Line. 29      <Source component="task1" pin="3" />
Line. 30      <Sink component="task2" pin="1" />
Line. 31    </Connector>
Line. 32  </Connectors>
Line. 33 </Assembly>

```

Figure 47: General Assembly Topology Description for Benchmarking Synthetic

In lines 13 and 16 of Figure 47, where **N** was the configured execution time for the instances of synthetic components being tested. **N** for this validation ranged from 5 to 20, inclusive. Figure 48 shows the general topological form for each synthetic component tested.

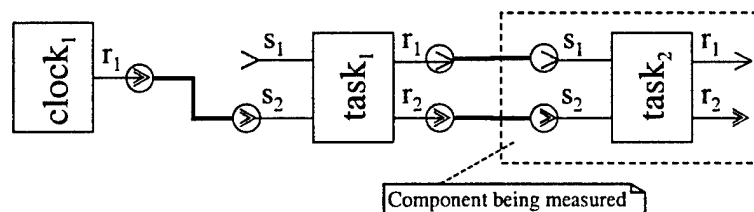

Figure 48: General Assembly Topology for Benchmarking Synthetic

Step 2: Execute each synthetic component through the runtime environment and capture its measured execution time.

The synthetic components are run using the sinktestscript.bat and measure2.bat scripts.

These scripts invoke the Pin runtime environment and assembly measurement environment using the test Pin component assemblies built in the previous step. Each test component assembly is run twice: once for the synchronous pin of the synthetic component (task2.s₁ ~> task2.s₁) and once for the asynchronous pin of the same synthetic component (task2.s₂ ~> task2.s₂). The test assembly is run until it is stopped by the assembly measurement environment. The measurement environment will cease measuring once it has achieved a 95% confidence interval in the latency of the measured reaction. In all cases, the 95% confidence interval was achieved before the minimum number of samples, which was set to 30.

Step 3: Update the Pin component description (registry) for each component tested with the captured measures from the runtime environment.

As the measurement environment measures the component from the runtime traces emanated from the runtime environment, it is continuously computing the average elapsed execution time (in milliseconds) and standard deviation. Once the 95% confidence interval is met, the measurement environment records the measures for the component and exits (thus causing the runtime environment to cease). The form of the results for each recorded assembly is shown in Figure 49.

```
Line. 1 <ComponentProperties
Line. 2   name="sinktest\sinktest10.xml.cfg"
Line. 3   pin="1" samples="30"
Line. 4   avgElapsedTime="13.39002667" stdDevElapsedTime="0.182646"/>
Line. 5 <ComponentProperties
Line. 6   name="sinktest\sinktest10.xml.cfg"
Line. 7   pin="2" samples="30"
Line. 8   avgElapsedTime="12.07455667" stdDevElapsedTime="0.023759"/>
```

Figure 49: Example Measures for Component Execution Time

In Figure 49, component synthetic10 has an average execution time for synchronous pin s₁ of 13.4ms with a standard deviation of 0.18ms and an average execution time for asynchronous pin s₂ of 12.1ms with a standard deviation of 0.02ms. The actual execution time for each synthetic component class is captured in Table 16 on page 112.

The measures collected by the measurement environment were transferred to the Pin component description for each synthetic component class tested in this procedure, essentially establishing those measures as the “certified” execution time properties for those components, under the runtime environment described in Section B.2.4.2.

B.2.3.2 Assembly Sample

Rather than arbitrarily selecting and manually building assemblies from the population of components (possibly introducing bias into the selection process), assemblies were randomly selected from a population of possible assemblies defined by assembly variation points. The variation points serve to define an assembly design space (a n -dimension coordinate system) of possible assemblies. For example, no assembly was considered for λ_{ABA} if it had more than 50 components. The following variation points were identified:

- number of clocks—the total number of Clock components discussed above that are used as a stimulus to other components within an assembly
- number of components—the total number of components, in this case, synthetic components, that make up an assembly
- number of connections per source pin—the maximum number of connections allowed for a single component's source pin to be connected to other components' sink pins
- minimum load factor—the minimum execution time for a component in the assembly. This number could range from 5 to 20 and had to be less than or equal to the maximum load factor.
- maximum load factor—the maximum execution time for a component in the assembly. This number could range from 5 to 20.
- harmonic period—determination of whether the clocks in the system have the same period
- minimum clock period—the minimum clock period for the clocks in the assembly. This value must be less than or equal to the maximum clock period.
- maximum clock period—the maximum clock period for the clocks in the assembly
- mixed connections—determination of whether the connections between the components in the assembly are homogeneous (all synchronous or all asynchronous) or heterogeneous (a mix of synchronous and asynchronous)
- percent blocking—percentage of the total number of synchronous pins used in the assembly that must be blocked or mutexed

Judgment is involved in defining variation points and their possible values.

To further facilitate the generation of synthetic assemblies, a set of tuples was defined that bound a value V' for a variation point (i.e., $\langle V_0', V_1', \dots, V_n' \rangle$). Each tuple represented, in some way, a stereotypical assembly. Thirteen such tuples were defined, again using judgment. An example tuple is shown in Figure 50; the complete set of tuples is shown in Table 9.

```

Line. 1 <Description name="1"
Line. 2   nofClocks="1" nofComponents="2"
Line. 3   nofConnectionsPerSrc="1"
Line. 4   minLoad="5" maxLoad="5"
Line. 5   harmonicPeriods="true"
Line. 6   minPeriod="20" maxPeriod="100"
Line. 7   mixedConnections="false"
Line. 8   percentblocking="50" />

```

Figure 50: Variation Points for One Assembly Design Space

Table 9: Variation Points for All Assembly Design Spaces

Assembly Design Space Tuple	# of Clocks	# of Components	# of Connections	Minimum Load (ms)	Maximum Load (ms)	Harmonic Period	Minimum Period (ms)	Maximum Period (ms)	Mixed Connections	% Blocking
1	1	2	1	5	5	Y	20	100	N	50
2	4	50	2	5	20	Y	500	1000	N	50
3	1	2	1	5	5	N	20	100	N	50
4	1	2	1	5	5	Y	20	100	Y	50
5	1	2	1	5	5	N	20	100	Y	50
6	2	4	1	5	10	Y	100	500	Y	0
7	2	8	1	5	10	N	20	100	N	100
8	2	8	1	5	10	N	20	100	Y	0
9	4	35	1	5	5	Y	500	2000	Y	100
10	2	4	1	5	5	Y	200	400	Y	25
11	4	15	1	5	5	Y	200	400	Y	25
12	2	15	3	20	20	Y	40	1200	Y	75
13	6	30	1	5	5	Y	200	400	Y	25

Each tuple (one row of Table 9) was given to the SEIAssemblyGeneratorController tool to randomly select an assembly from the design space. Each generated assembly was tested for λ_{ABA} well-formedness per the rules described in Appendix A. If the assembly was not well formed, it was rejected, and the assembly generator would randomly select another assembly from the design space. This process repeated until a well-formed (i.e., analyzable) assembly was found, or the assembly generator reached an upper-bound search heuristic and terminated.

For the version of the assembly generator used in this validation exercise, that upper bound was set to look at 150 random assemblies before giving up.³⁵

Although our approach to random assembly generation worked for our needs, it proved to be inefficient; in future versions, we will assume that each interpretation will be bundled with its own assembly generator.

Figure 51 is one of the assemblies generated randomly from tuple #1 (i.e., the first row in Table 9).

```
Line. 1 <?xml version="1.0" encoding="utf-8" standalone="yes"?>
Line. 2 <Assembly xmlns="PinTekXML.xsd">
Line. 3   <Components>
Line. 4     <Component name="Clock0" type="clock">
Line. 5       <Property propId="period" value="40" />
Line. 6     </Component>
Line. 7     <Component name="C1" type="synthetic5">
Line. 8       <Property propId="measurement" value="true" />
Line. 9       <Property propId="priority" value="68" />
Line. 10      <Property propId="loadFactor" value="5" />
Line. 11      <Property propId="blocking" value="true" />
Line. 12     </Component>
Line. 13     <Component name="C2" type="synthetic5">
Line. 14       <Property propId="measurement" value="3" />
Line. 15       <Property propId="priority" value="124" />
Line. 16       <Property propId="loadFactor" value="5" />
Line. 17       <Property propId="blocking" value="false" />
Line. 18     </Component>
Line. 19   </Components>
Line. 20   <Connectors>
Line. 21     <Connector>
Line. 22       <Source component="Clock0" pin="0" />
Line. 23       <Sink component="C1" pin="1" />
Line. 24     </Connector>
Line. 25     <Connector>
Line. 26       <Source component="C1" pin="3" />
Line. 27       <Sink component="C2" pin="1" />
Line. 28     </Connector>
Line. 29   </Connectors>
Line. 30 </Assembly>
```

Figure 51: Example of a Randomly Selected Assembly

35. An additional search heuristic could be added if an assembly is not found within a specified period of time. For this validation experiment, most assemblies were found within 10 minutes. Looking for longer than 20 minutes seemed to be fruitless. Perhaps a better approach would be to construct an assembly that is analyzable, rather than selecting assemblies at random.

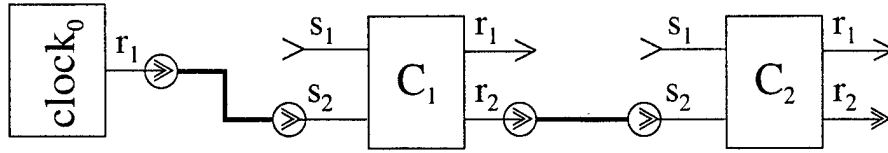

Figure 52: Topology of an Example of a Randomly Selected Assembly

Given an analyzable assembly, the tool then simulated its execution considering the number of jobs found within it. Each job would be traced, and latency for the job would be computed via simulation using the “certified” execution time properties for each pin used on each component in the sequence of components used in that job (see Section B.2.5.1). The latency computed for the job became the prediction for the latency of that job for that assembly. For the assembly shown in Figure 52, the calculated prediction (based on the component property for pin 1 of the synthetic5 component [see Table 16 on page 112]) is shown in Table 10.

Table 10: Predicted Latency for Synthetic5’s Job

Task	Job	Predicted Latency (ms)	Standard Deviation (+/- ms)
1	1	12.1573	0.022722

Task #1 (from Table 10) refers to the job beginning with component instance clock0 in the assembly. Job #1 is the “longest path” emanating from the clock that can be predicted. Since, in this assembly, there is only one “path” (i.e., $\text{clock0.r}_1 \rightsquigarrow \text{c}_1.\text{s}_2, \text{c}_1.\text{r}_2 \rightsquigarrow \text{c}_2.\text{s}_2$), it is, by default, the “longest path” and therefore the only job—hence one prediction. Predicted latency is the prediction for the average number of milliseconds it will take to complete one period in the hyper-period for the job, which for Task #1, Job #1 is 11.75ms. The standard deviation is the computed standard deviation for the prediction (in milliseconds).

With a prediction for each job in each defined and randomly selected assembly (with only one being shown above), each assembly was run through the runtime environment using the assemblytestscript.bat and measureAssembly.bat scripts. These scripts invoke the Pin runtime environment and assembly measurement environment using the randomly selected component assemblies. Each random component assembly is run once for each job found in the assembly so that it can be measured independently from any other executing jobs in the assembly. Each assembly job is run until it is stopped by the assembly measurement environment. That environment will cease measuring once it has collected N samples (which in this case was 30).

The measurement environment computes continuously, from time-stamped Pin events, the average elapsed time (in milliseconds), and the standard deviation of assembly execution. Upon completion of the measurement process, the measurement environment records the mea-

asures for the assembly and exits. The form of the results for each recorded assembly is shown in Table 11.

Table 11: *Observed Average Latency for an Assembly*

Task	Job	Samples	Average Latency (ms)	Standard Deviation (+/- ms)
1	1	660	12.180839727	0.002032986

Table 11 is very similar to the table described above for recording the prediction. The differences are that after successfully measuring a job for an assembly, the total number of latency samples observed are recorded (in this case, Samples = 30), and the computed arithmetic mean (i.e., Average Latency = 12.05ms) is calculated.

Finally, the sampling process for measuring and recording the actual assembly latencies for each job in all the selected random assemblies was repeated 22 times resulting in 22 complete sets of observations, with $N = 30$ for each observation (effectively, $N = 22 \times 30$).

The actual assembly latencies observed for each job are captured in Table 17 on page 113.

B.2.4 Develop Measurement Infrastructure

Clearly, the preceding discussion assumes the availability of a measurement infrastructure. The infrastructure described here was developed to support the sampling procedure outlines in Section B.2.3. We expect a large portion of this infrastructure to be reusable by other property theories, not necessarily time-based ones.

B.2.4.1 Measurement Tool Suite

The complete measurement infrastructure required to obtain measurement data on the components and assemblies used in the empirical validation is discussed briefly below.

The overall control and data flow for the tools created for the empirical validation is shown in Figure 53. Component execution time is measured by placing components in a test harness—essentially an assembly occupied only by the component (the Composer tool). An assembly generator uses variation points (the tuples described earlier) to generate well-formed assemblies from measured components. The generated assemblies are then executed in an instrumented runtime that records actual job latencies. This data is then compared with predictions to produce statistical labels for λ_{ABA} .

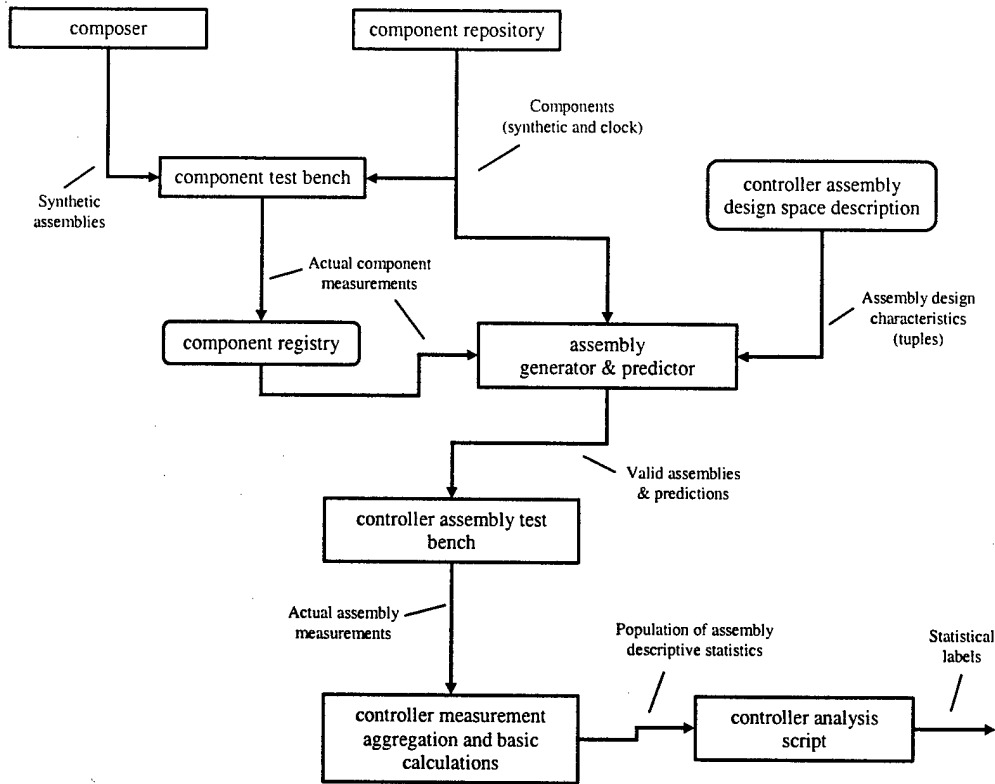

Figure 53: Measurement Infrastructure Tool Workflow

The specific tools that were created and their purposes are shown in Table 12.

Table 12: Measurement Infrastructure Tool Suite

Workflow Element/Tool	Purpose
Component repository	
reg.bat	Registers RTX components (.rtdlls) with the RTX Runtime executive
*.rtdll	RTX components
*.dll	WIN32 components
Composer	
createsinktest.bat	Outer control loop, iterating from 5 to 20 times as arguments for the component assembly generator script
createonesinktest.bat	Component assembly generator script, creating a simple assembly for testing a single component. The name of the component is passed as an argument.
XML2CFGsinktest.bat	Outer control loop, iterating over the assemblies generated by the component assembly generator and passing the generated XML file to the XML-to-CFG translator

Table 12: Measurement Infrastructure Tool Suite (Cont'd.)

Workflow Element/Tool	Purpose
Composer (cont'd.)	
SEITranslateAssembly-fromXML.exe	XML-to-CFG translator that converts an assembly generated by the component assembly generator from an XML representation to a CFG representation suitable for consumption by the RTX Pin Runtime
Component test bench	
sinkttestscript.bat	Outer control loop, iterating over the assemblies generated by the component assembly generator and passing the converted CFG file to the main measurement script
measure2.bat	Main measurement script overseeing the execution of the assembly in the RTX Pin Runtime and measured by the RTX Assembly Measurement tool. When the RTX Assembly Measurement tool is complete, the script kills the RTX Pin Runtime and exits.
results2.xml	Component measurements (results) of actual values captured by the RTX Assembly Measurement tool.
Component test bench OR controller assembly test bench	
Runtime.rtss	RTX Pin Runtime. Besides executing the Pin assembly, the RTX Pin Runtime generates measurement events that are consumed by the RTX Assembly Measurement tool.
assemblymsrmt.rtss	RTX Assembly Measurement tool. Reads measurement events generated by the RTX Pin Runtime and calculates the job execution time for a hyper-period based on command line arguments
mywait.bat	Used to pause the execution of the main measurement script until the RTX Pin Runtime has been signaled by the RTX Assembly Measurement tool that it is complete. The mywait.bat script and the RTX Assembly Measurement tool do this signaling through the creation and removal of a file in the file system.
wait.exe	A tool designed to block (wait) for N seconds using native WIN32 calls for sleep() (a non-busy wait)
killruntime.rtss	Used to signal the RTX Pin Runtime to suspend execution of the assembly and exit
rtx-hack.exe	A tool that is used to aid the continuous, non-human interactive execution of the RTX Pin Runtime. A bug in the RTX executive causes the generation of an RTX exception that can be dismissed only by pressing a button on the exception dialog. This WIN32 application looks for that dialog and dismisses the dialog automatically.

Table 12: Measurement Infrastructure Tool Suite (Cont'd.)

Workflow Element/Tool	Purpose
Component registry	
components.xml	Registration information about components available for use within the Pin Runtime environment. This file contains path locations to the components in the file system as well as pin configurations and measurement data for those components.
components.cfg	RTX-Pin-Runtime-translated version of the XML representation of the same name. This file is suitable for use with the RTX Pin Runtime.
XML2CFGcomponents.bat	Simple one-line script for running the XML-to-CFG translator for the component registry
SEITranslateComponentsXML.exe	XML-to-CFG translator that converts a component registry from an XML representation to a CFG representation suitable for consumption by the RTX Pin Runtime
Controller assembly design space description	
ControllerValidationDescr.xml	XML file that describes a number of valid design spaces from which assemblies can be selected randomly
Assembly generator and predictor	
SEIAssemblyGeneratorController.exe	Outer control loop, iterating over randomly selected assemblies from a predetermined assembly design space. The selected assembly is passed to the Pin Runtime simulator for rejection (a non-schedulable assembly) or prediction (a schedulable assembly).
AsyncGen.exe	Pin Runtime simulator. If the assembly is schedulable, a prediction is made for each job within the assembly. If it is not schedulable, the assembly is rejected.
SEI_#_*.xml	Assembly that is generated by the SEIAssemblyGeneratorController.exe script and deemed schedulable by the Pin Runtime simulator
SEI_#_*.cfg	CFG representation of the XML assembly generated by the SEITranslateAssemblyfromXML.exe script
SEI_#_*.csv	Prediction made for each job in the assembly by the Pin Runtime simulator
SEI_#_*.lpi	"Longest path" information for each job within an assembly
XML2CFGassemblies.bat	Outer control loop, iterating over the assemblies generated by the SEIAssemblyGeneratorController.exe script assembly generator and passing the generated XML file to the XML-to-CFG translator
SEITranslateAssemblyfromXML.exe	XML-to-CFG translator that converts an assembly generated by the component assembly generator from an XML representation to a CFG representation suitable for consumption by the RTX Pin Runtime

Table 12: Measurement Infrastructure Tool Suite (Cont'd.)

Workflow Element/Tool	Purpose
Assembly generator and predictor (cont'd.)	
sed	Tool used to patch the generated CFG file due to a bug in the Pin Runtime simulator
Controller assembly test bench	
doemall.bat	Outermost control loop to repeat execution of all the assemblies generated by the SEIAssemblyGenerator-Controller.exe script and the Pin Runtime simulator. As configured, this script will repeat the run of the entire set of assemblies 40 times.
2assemblytestscript.bat	Support script for the outermost control loop
assemblymeasure.bat	Inner control loop to manage the execution of all generated assemblies
measureAssembly.bat	Main assembly measurement script overseeing the execution of the assembly in the RTX Pin Runtime and measured by the RTX Assembly Measurement tool. When the RTX Assembly Measurement tool is complete, the script kills the RTX Pin Runtime and exits.
Controller measurement aggregation and basic calculations	
pcfu_analysis_v2.xls	Excel spreadsheet to collect all the measurements recorded by the Pin Measurement tool into one place. Performs basic descriptive statistics on the data and aggregates (such as Average, MRE, and standard deviation). Other sheets within the Excel workbook include those on graph generation and other manual aids for analysis.
Module1.gatherpredictions()	Excel.VBA script for automating the inclusion and aggregation of recorded measurement data
Module1.paccCompare()	Excel.VBA script for automating the separation of actual latency records from the bulk of other collected data. Also aids in analysis.
Module1.paccCompareAVG()	Excel.VBA script for automating the separation of Actual MREs calculated from the bulk of other collected data. Also aids in analysis.
Controller analysis script	
pect1.exe	Script used for automating the analysis that determines the statistical labels from the experiment
StInt.exe	Tool created by Hahn and Meeker that comes complete with a rudimentary statistical scripting language [Hahn 91]

B.2.4.2 Test Environment

Execution time properties for components, as well as assembly job latency, are directly affected by the runtime environment. Such properties include both hardware (e.g., processor speed) and software (e.g., operating system) properties. The significant hardware and software features and configurations are listed in Table 13 and Table 14, respectively.

Table 13: Hardware Characteristics

Item	Value
System Manufacturer	Dell Computer Corporation
System Model	DIM4400
Processor	x86 Family 15 Model 1 Stepping 2 GenuineIntel ~1595 Mhz
Physical Memory	1,047,856 KB 184-pin DIMM PC2100
Virtual Memory	3,570,352 KB
Hard Disk 1	WDC WD400BB-75CAA0 40 GB 7200 RPM 2 MB Buffer 8.9 ms Average Read Seek Time

Table 14: Software Characteristics

Item	Value
Operating System Name	Microsoft Windows 2000 Professional 5.0.2195 Service Pack 2 Build 2195
Compiler	Microsoft Visual C# .NET 1.0 Build 3705
Compiler	Microsoft Visual Studio C++ 6.0 Service Pack 5
Real-Time Extensions	VenturCom RTX 5.1.1 Build 3517

Additionally, the property values collected can be affected by other operating and user processes currently running on the machine. All opportunities were taken to “quiet” the runtime environment. Table 15 lists all the residual processes running at test time.

Table 15: Processes (Running Tasks)

Name	Version
smss.exe	5.00.2195.2901
csrss.exe	5.00.2195.2581
winlogon.exe	5.00.2195.2953
services.exe	5.00.2195.2780
lsass.exe	5.00.2195.2964
svchost.exe	5.00.2134.1
spoolsv.exe	5.00.2161.1
svchost.exe	5.00.2134.1
mdm.exe	7.00.9466
regsvc.exe	5.00.2195.2104
mstask.exe	4.71.2195.1
winmgmt.exe	1.50.1085.0029
logon.scr	5.00.2195.2104

B.2.5 Collect Validation Data

B.2.5.1 Component Execution Times

Table 16 lists the actual execution times recorded for each synthetic Pin component.

Table 16: Recorded Actual Execution Time Per Synthetic Pin Component

Component	Pin	Samples	Average Execution (ms)	Standard Deviation (+/- ms)
synthetic5	s1	30	6.86182667	0.113103
	s2	30	6.08006000	0.016712
synthetic6	s1	30	8.15998000	0.052514
	s2	30	7.28474333	0.019437
synthetic7	s1	30	9.44960000	0.109422
	s2	30	8.48425333	0.019146
synthetic8	s1	30	10.90788667	0.236071
	s2	30	9.67879333	0.023449
synthetic9	s1	30	12.22811333	0.240077
	s2	30	10.87083667	0.020344
synthetic10	s1	30	13.39002667	0.182646
	s2	30	12.07455667	0.023759

Table 16: Recorded Actual Execution Time Per Synthetic Pin Component (Cont'd.)

Component	Pin	Samples	Average Execution (ms)	Standard Deviation (+/- ms)
synthetic11	s1	30	14.75889667	0.200467
	s2	30	13.26221000	0.025504
synthetic12	s1	30	16.13946333	0.198329
	s2	30	14.45731333	0.022695
synthetic13	s1	30	17.50676667	0.283673
	s2	30	15.64764333	0.027561
synthetic14	s1	30	18.77334667	0.253397
	s2	30	16.85212000	0.026781
synthetic15	s1	30	20.31739000	0.340785
	s2	30	18.06251000	0.028431
synthetic16	s1	30	21.42600667	0.214585
	s2	30	19.24452333	0.024071
synthetic17	s1	30	22.79329667	0.318561
	s2	30	20.44261000	0.019831
synthetic18	s1	30	24.41882667	0.371608
	s2	30	21.63316667	0.034281
synthetic19	s1	30	25.44057000	0.319016
	s2	30	22.83103333	0.028673
synthetic20	s1	30	26.92379000	0.018289
	s2	30	24.03515000	0.027394

B.2.5.2 Assembly Latencies

Table 17 lists the predicted and actual latencies recorded for each job.

Table 17: Recorded Predicted and Actual Latencies Per Job

Sample	Assembly	Task	Job	Predicted Latency (ms)	Average Latency (ms)	Average MRE (+/- ms) (AVGMRE)	Standard Deviation
1	0	1	1	12.157434	12.18083973	0.002032986	0.00324926
2	11	1	1	152.203193	142.799986	0.065854237	0.00246545
3	11	2	1	223.729849	212.6520431	0.05209464	0.001081566

Table 17: Recorded Predicted and Actual Latencies Per Job (Cont'd.)

Sample	Assembly	Task	Job	Predicted Latency (ms)	Average Latency (ms)	Average MRE (+/- ms) (AVGMRE)	Standard Deviation
4	11	3	1	146.121677	136.7693409	0.068383718	0.001940991
5	11	3	2	108.057513	105.05552	0.028578573	0.001880233
6	11	3	3	108.057513	105.0776989	0.028361911	0.002002774
7	11	3	4	108.057513	105.0631347	0.028504362	0.001974737
8	11	4	1	295.342878	288.4779173	0.023797326	0.000396185
9	11	4	2	179.670542	175.1159935	0.026009175	0.000673052
10	11	4	3	179.670542	175.1231314	0.025967301	0.000628656
11	11	4	4	179.670542	175.1215062	0.025976785	0.000595791
12	12	1	1	36.480324	36.37326986	0.002992374	0.004488773
13	12	2	1	12.160088	12.14966386	0.002546474	0.002390286
14	14	1	1	106.664623	98.74003155	0.080265901	0.003149035
15	14	2	1	140.99133	128.7704897	0.094915768	0.00366488
16	14	3	1	38.77888	37.785479	0.026291032	0.000720778
17	14	3	2	19.797934	18.8435535	0.050657309	0.003273501
18	14	4	1	72.319747	68.42918259	0.05685782	0.001654267
19	14	4	2	53.338801	49.53426291	0.076814768	0.003101751
20	15	1	1	48.077234	47.991087	0.001796969	0.001954304
21	16	1	1	6.077805	6.090317524	0.002716543	0.004810158
22	18	1	1	6.077805	6.087613143	0.00254476	0.004380116
23	19	1	1	6.077805	6.098547095	0.003650455	0.003595587
24	1	1	1	593.455008	634.2910765	0.063112852	0.034704991
25	1	2	1	995.947936	995.237053	0.000714403	0.000352653
26	1	3	1	754.927901	754.6399139	0.000381712	0.000307332
27	1	4	1	553.665296	460.40705	0.202556121	0.000236622
28	21	1	1	6.077805	6.085927095	0.003089996	0.005467769
29	22	1	1	24.050608	23.97978685	0.004547764	0.007049814
30	22	2	1	14.563308	14.548268	0.001903489	0.001232084
31	22	2	2	8.484954	8.485028048	0.00379372	0.004132209
32	23	1	1	72.517056	72.18012165	0.004674646	0.002663979
33	23	2	1	41.099661	41.00429876	0.002684425	0.001086994
34	24	1	1	65.423428	62.56047962	0.000855418	0.001615869
35	24	2	1	6.078576	6.101276	0.004783627	0.00422444

Table 17: Recorded Predicted and Actual Latencies Per Job (Cont'd.)

Sample	Assembly	Task	Job	Predicted Latency (ms)	Average Latency (ms)	Average MRE (+/- ms) (AVGMRE)	Standard Deviation
36	25	1	1	69.193544	66.0317199	0.047897211	0.003892495
37	25	2	1	16.965219	16.94532629	0.001287014	0.00117919
38	27	1	1	233.000651	233.7746158	0.063037527	0.058178158
39	27	2	1	304.571515	279.4908092	0.101757274	0.128024805
40	27	3	1	445.338419	429.3696862	0.03719116	0.000247189
41	27	3	2	140.766904	137.2639743	0.025519674	0.00013175
42	27	4	1	161.388063	155.6482179	0.036877181	0.000394938
43	28	1	1	12.156365	12.10472462	0.00780738	0.013553423
44	28	2	1	31.940761	31.87197114	0.002436647	0.000894564
45	28	2	2	25.86259	25.797565	0.002891515	0.001465898
46	2	1	1	12.157434	12.19095824	0.003216353	0.003132189
47	30	1	1	207.820552	172.1396488	0.212449269	0.077072795
48	30	1	2	70.788164	67.99884624	0.041023116	0.001819544
49	30	2	1	187.238652	192.6022863	0.059528467	0.026309187
50	30	3	1	166.674934	135.7480596	0.227828031	0.00179305
51	30	4	1	146.123674	117.9770064	0.238577791	0.000535831
52	31	1	1	1087.456557	1032.780649	0.052941272	0.000932037
53	31	2	1	1036.499941	788.6200498	0.314321675	0.000919638
54	3	1	1	6.077805	6.092341667	0.003273897	0.003919068
55	5	1	1	12.908483	12.92091581	0.001746366	0.002360845
56	7	1	1	20.554505	20.53108629	0.002418703	0.002413149
57	7	1	2	20.554505	20.50707924	0.003266289	0.002385814
58	7	1	3	20.554505	20.51884838	0.002771204	0.002421099
59	7	1	4	20.554505	20.51021686	0.003258122	0.002549417
60	7	1	5	20.554505	20.51467581	0.002937428	0.002512625
61	7	2	1	48.552451	48.50180686	0.001356255	0.000789963
62	8	1	1	58.062533	58.01301033	0.000994399	0.00057472
63	8	2	1	37.516312	37.45211567	0.002025215	0.000869905
64	9	1	1	64.903463	64.92833071	0.002105629	0.001895588
65	9	2	1	32.412077	32.43519214	0.001379683	0.001714629

B.2.6 Analyze Results

The goal of the analysis study for empirically validating the property theory (in Appendix A) was to support or refute the hypothesis that λ_{ABA} would predict the latency for any job within the hyper-period with an MRE ≤ 0.05 with a confidence level $\gamma = 0.99$. A minimum acceptable $p = 80\%$ was established for a pass/fail condition.

B.2.6.1 Computations

Each time a job was executed during the sampling procedure, the actual latency and standard deviation was recorded. Recall that this was done 22 times. Therefore, our measurement environment recorded 22 average latencies for each job where each recorded average latency could be compared against the original prediction for that job (see Section B.2.5.2).

The MRE for each recorded and observed average latency was calculated for job using this equation:

$$\text{MRE} = \left| \frac{\text{Predicted} - \text{Actual}}{\text{Actual}} \right|$$

This resulted in having 22 MREs computed for each job executed. From those MREs, the arithmetic mean and standard deviation (AVGMRE) of each job was computed. The result of that computation is found in Table 17.

B.2.6.2 Descriptive Statistics

Table 18 includes some basic descriptive statistics for the assembly measures recorded in Table 17.

Table 18: Descriptive Statistics for Job Assembly Measurements

Part of Interval	Value
Samples (N)	65
Mean MRE (mAVGMRE)	0.039612786
Standard Deviation (s)	0.064798
Spearman rank correlation of Predicted Latency and Average Latency ^a	0.997 p-Value < 0.001

- a. A high correlation (closer to -1.0 or 1.0) is an indication of correlation between the predicted latency and average latency. P-value is the probability that any such correlation is a coincidence. For a small p-value, reject the hypothesis that the correlation is a coincidence. Spearman's correlation is a non-parametric correlation and does not make assumptions about the data (i.e., normality).

B.2.6.3 Normality Test

The Shapiro-Wilk normality test was used to support (or refute) the hypothesis that the populations of job AVGMREs was normal. Depending on the result, different forms of intervals must be used. The results from the Shapiro-Wilk normality test are shown in Table 19.

Table 19: Results from the Shapiro-Wilk Normality Test on AVGMRE

W statistic	p-value
0.6266	1.383e-11

Since the p-value is less than the generally accepted critical p-value of 0.05, the hypothesis that the MREs for the jobs are normally distributed was rejected.

Next, a logarithmic transformation was applied to the AVGMREs with the intent to make them normally distributed. That is, each AVGMRE in the population was transformed using LOG(AVGMRE) and a new population was created. Again, the Shapiro-Wilk normality test also refuted that the new, transformed population was normal because the p-value, although much improved, was still smaller than the critical p-value of 0.05.

Table 20: Results from the Shapiro-Wilk Normality Test on LOG(AVGMRE)

W statistic	p-value
0.9217	5.282e-04

Similarly, a Box-Cox transformation also failed to produce a normal distribution (varying $\lambda = \{ 5.0, 0.5, 0.3, 0.1, 0.01 \}$ ³⁶). Histograms of the AVGMRE and LOG(AVGMRE) population are shown in Figures 54 and 55 below.

36. As the λ -values approach 0, the transformation approaches the logarithmic transformation performed earlier. This is not surprising, because the Box-Cox transformation for λ -value 0 equals LOG().

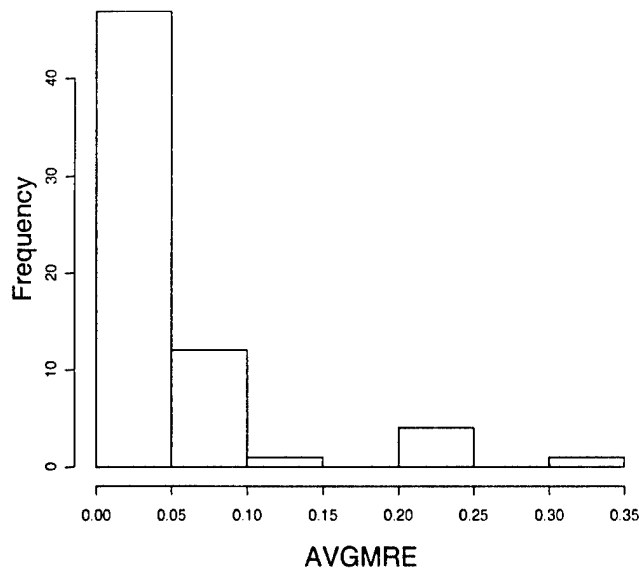

Figure 54: Histogram of AVGMRE Job

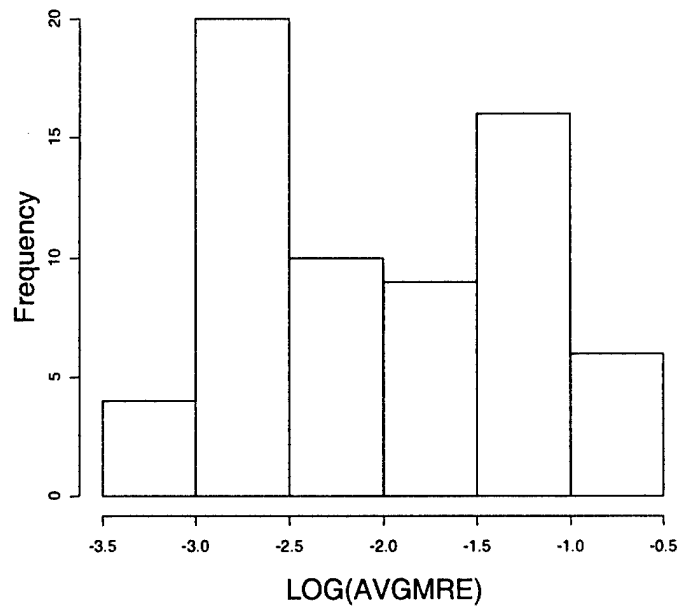

Figure 55: Histogram of LOG(AVGMRE) Job

Given that the population of the AVGMRE job data is not normal, normal distribution statistical intervals cannot be used. Therefore, distribution-free statistical intervals had to be used to compute the tolerance and confidence intervals.

B.2.6.4 One-Tail Distribution-Free Statistical Intervals

The upside to using distribution-free statistical intervals is that there are no assumptions about the data's normality. Given that the population of the AVGMREs recorded is not normal, this upside is an incentive for using distribution-free intervals. However, the downside is that it is difficult to achieve, precisely, the desired confidence intervals. Further, the intervals that are determined tend to be longer than those derived from normal distributions. One reason for this difference is that such statistical methods do not require parameters to the formulae and table lookups (such as standard deviation) that are used to determine either tolerance or confidence intervals for distribution-free populations³⁷ [Hahn 91].

The goal for this analysis is to support or reject the hypothesis that the λ_{ABA} will predict the latency of a job to have an $MRE \leq 0.05$. This is the upper bound for an MRE interval representing situations where predictions would be *no worse* than the μMRE for a job. Notice that the lower bound for an MRE interval would represent situations where the predictions would be *no better* than the μMRE for a job. Thus, knowing both ends of the interval (a two-tail interval) is not the goal of this analysis study, as only the upper-bound interval (a one-tail interval) is of interest.

StInt, a tool that performs a number of different kinds of statistical intervals (including distribution-free intervals), was used to determine the tolerance interval for the population of job AVGMREs [Meeker 93]. The first calculation performed is shown in Figure 56 where

- $p=0.80$ is the proportion of the percentile of the population to compute the interval.
- $k_{side}=2$ is the upper tolerance bound.
- $conlev=0.99$ is the desired confidence level.

```
Line. 1 stint> dfti p=0.80 kside=2, conlev=0.99
Line. 2 finding a nonparametric 99.0% upper confidence bound
Line. 3 for the 80.0 percentile.
Line. 4 this is also a 99.0% upper tolerance bound to exceed at
Line. 5 least
Line. 6 80.0% of the population.
Line. 7 the interval (bound) is based on 65 observations.
Line. 8 the desired upper bound is x( 60).
Line. 9 the actual confidence level is= 0.9942
Line. 10
Line. 11 ordered observation number 60 is 0.10
```

Figure 56: Distribution-Free Calculation Using StInt

37. Distribution-free statistical intervals are also referred to as non-parametric statistical intervals.

The result of this initial calculation is that our hypothesis for achieving an $MRE \leq 0.05$ was not supported. The upper-bound tolerance we could expect to achieve based on this population ($N=65$, line 7 above) was, at best, 0.10 (or 10% MRE, line 11 above) for 80% of the population, with an actual confidence level of 99.42% (line 9 above).

Table 21: Results from the Initial Calculation for a One-Sided Distribution-Free Tolerance Interval

Part of Interval	Value
$N = 65$	sample size
$\gamma = 0.9942$	confidence level
$\rho = 0.80$	proportion
$\mu_{MRE} = \sim 0.04$	mean MRE
UB = 10%	upper bound

Based on trial and error (iterating through different values of ρ), it was determined that an upper-bound tolerance of 5% MRE could be achieved for 62% of the population with an actual confidence of 99.22%.³⁸

These results were somewhat surprising. Why were they so far off in that we could only achieve 10% MRE for our target population? It was time to look at the data.

B.2.6.5 Revisiting the Data

Referring back to the histograms in Figures 54 and 55, on page 118, there was a noticeable skewing of the data, and the histograms did not provide much insight. Next, upon inspecting the data closer in Table 17, we immediately noticed (on the whole) that much of the measurements were very stable ($\sigma \leq 0.10$) and fell into two general regions (see Figure 57):

1. Region 1—samples whose calculated MRE was within our goal ($MRE \leq 0.05$)
2. Region 2—samples whose calculated MRE was outside our goal ($MRE > 0.05$)

38. `dfti p=0.62, kside=2, and conlev=0.99.`

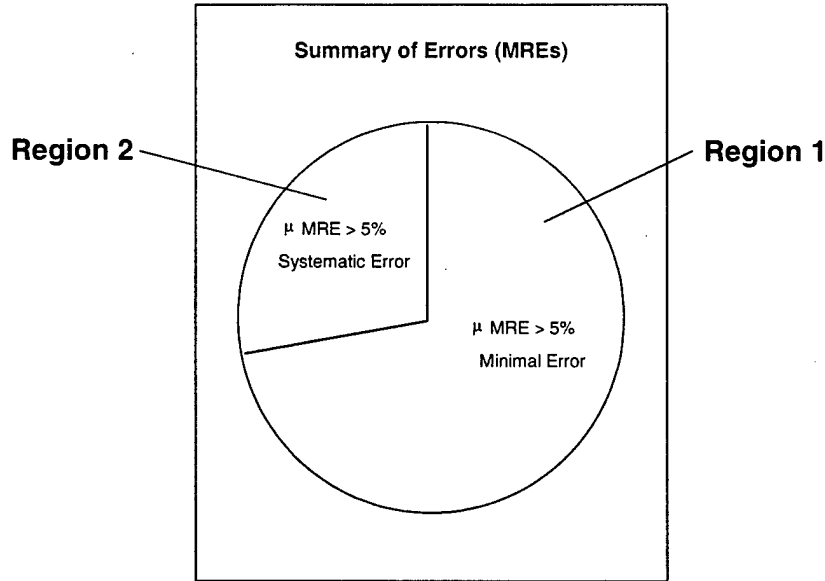

Figure 57: Summary of the AVGMRE Job Grouped by MRE

From this perspective of the data, two hypotheses were formulated:

1. Hypothesis 1 (Region 1 only): Removing the systematic error (indicative of a possible error in the λ_{ABA} property theory, its interpretation, or the runtime) would improve the confidence and tolerance intervals, allowing us to achieve our analytic goal.
2. Hypothesis 2 (All Regions): The systematic errors in the population could not be found or corrected, and the confidence and tolerance intervals calculated in Section B.2.6.4 would stand.

To test hypothesis 1, the original data set of 65 observations recorded in Table 17 was reduced by those observations represented as Region 2 in Figure 57. As a result, the data set for hypothesis 1 AVGMRE consisted of 47 observations. (Those observations in Region 2 were removed.) The descriptive statistics for hypothesis 1 are shown in Table 22. (Hypothesis 2 is also repeated here for the reader's convenience.)

Table 22: Descriptive Statistics for Hypothesis Data Sets

Statistic	Hypothesis 1 AVGMRE	Hypothesis 2 AVGMRE
Samples (N)	47	65
Mean MRE (mAVGMRE)	0.010487	0.039612786
Standard Deviation (s)	0.013375	0.064798
Spearman rank correlation of Predicted Latency and Average Latency	0.997 p-Value < 0.001	0.997 p-Value < 0.001

Using the StInt tool again, the one-sided, distribution-free tolerance intervals were computed for the Region 1 data set (see Table 23). From these calculations, the upper-bound tolerance interval improved substantially. The data set of AVGMREs for hypothesis 1 (Region 1), using a one-sided, distribution-free tolerance interval, improved to 4% MRE for 80% of the population with a confidence of 99.07%.

Table 23: Hypothesis Calculations for a One-Sided, Distribution-Free Tolerance Interval

Part of Interval	Hypothesis 1 AVGMRE	Hypothesis 2 AVGMRE
N	47	65
γ	0.9907	0.9942
ρ	0.80	0.80
μ_{MRE}	~0.01	~0.04
UB	4%	10%

Next, the Region 1 data set was tested for normality and failed the Shapiro-Wilk test. A logarithmic transformation of the Region 1 data set also failed that test. We would have to live with the distribution-free analysis for now.

These results are encouraging. That is, if both the systematic errors can be found and solved for the λ_{ABA} (i.e., hypothesis 1) and future results follow the representative population of AVGMRE (having minimal errors), we can expect to achieve an MRE < 5% for 80% of the predictions with a confidence of 99%. But that still has to be proven.

B.2.7 Final Statistical Labels

Table 24 is a compilation of the data from the previous sections organized according to the two hypotheses derived from revisiting that data (see Section B.2.6.5 on page 120). Hypothesis 2 corresponds to the results of the actual validation. All calculations assume a distribution-free tolerance interval.

Table 24: Final Statistical Labels for All Hypotheses

Part of Interval	Hypothesis 1	Hypothesis 2
sample size (N)	47	65
confidence level (γ)	0.9907	0.9942
proportion (ρ)	0.80	0.80
mean MRE (μ_{MRE})	~0.01	~0.04
upper bound (UB)	4%	10%

B.3 Conclusions

The goal for the λ_{ABA} property theory that the latency for a job within the hyper-period can be predicted with an $MRE \leq 0.05$ with a confidence level $\gamma = 0.99$ for at least 80% of the population was not supported and was thereby rejected.

It appeared that the first 75% of the job MRE predictions (47 of 65, the optimistic observations) were represented well by the λ_{ABA} , which was encouraging. The remainder of those predictions appeared to be systematic errors that warrant further investigation either wrongly accounted for in λ_{ABA} or not represented at all. It is also feasible that either the runtime or measurement environment, or both, could be at fault. In any event, further co-refinement of λ_{ABA} is required.

B.4 StInt Program

The StInt program contains the following code:

```
Line. 12 batch
Line. 13 c
Line. 14 c # Actual AVGMRE (Region 1) dataset
Line. 15 c
Line. 16 read 47 observations
Line. 17 0.002032986, 0.028578573, 0.028361911, 0.028504362,
Line. 18 0.023797326, 0.026009175, 0.025967301, 0.025976785,
Line. 19 0.002992374, 0.002546474, 0.026291032, 0.001796969,
Line. 20 0.002716543, 0.00254476, 0.003650455, 0.000714403,
Line. 21 0.000381712, 0.003089996, 0.004547764, 0.001903489,
Line. 22 0.00379372, 0.004674646, 0.002684425, 0.000855418,
Line. 23 0.004783627, 0.047897211, 0.001287014, 0.03719116,
Line. 24 0.025519674, 0.036877181, 0.00780738, 0.002436647,
Line. 25 0.002891515, 0.003216353, 0.041023116, 0.003273897,
Line. 26 0.001746366, 0.002418703, 0.003266289, 0.002771204,
Line. 27 0.003258122, 0.002937428, 0.001356255, 0.000994399,
Line. 28 0.002025215, 0.002105629, 0.001379683
Line. 29 c
Line. 30 c # Calculate mean and stdev
Line. 31 c
Line. 32 cndata
Line. 33 c
Line. 34 c # distribution free one-tail tolerance interval
Line. 35 c
Line. 36 dfti p=0.80 kside=2, conlev=0.99
Line. 37 c
Line. 38 c # Actual AVGMRE (Region 1 + Region 2) dataset
Line. 39 c
Line. 40 read 65 observations
Line. 41 0.002032986, 0.065854237, 0.05209464, 0.068383718,
Line. 42 0.028578573, 0.028361911, 0.028504362, 0.023797326,
```

```
Line. 43 0.026009175, 0.025967301, 0.025976785, 0.002992374,  
Line. 44 0.002546474, 0.080265901, 0.094915768, 0.026291032,  
Line. 45 0.050657309, 0.05685782, 0.076814768, 0.001796969,  
Line. 46 0.002716543, 0.00254476, 0.003650455, 0.063112852,  
Line. 47 0.000714403, 0.000381712, 0.003089996, 0.004547764,  
Line. 48 0.001903489, 0.00379372, 0.004674646, 0.002684425,  
Line. 49 0.000855418, 0.004783627, 0.047897211, 0.001287014,  
Line. 50 0.063037527, 0.03719116, 0.025519674, 0.036877181,  
Line. 51 0.00780738, 0.002436647, 0.002891515, 0.003216353,  
Line. 52 0.041023116, 0.059528467, 0.052941272, 0.003273897,  
Line. 53 0.001746366, 0.002418703, 0.003266289, 0.002771204,  
Line. 54 0.003258122, 0.002937428, 0.001356255, 0.000994399,  
Line. 55 0.002025215, 0.002105629, 0.001379683, 0.202556121,  
Line. 56 0.212449269, 0.227828031, 0.238577791, 0.314321675,  
Line. 57 0.101757274  
Line. 58 c  
Line. 59 c # Calculate mean and stdev  
Line. 60 c  
Line. 61 cndata  
Line. 62 c  
Line. 63 c # distribution free one-tail tolerance interval  
Line. 64 c  
Line. 65 dfti p=0.80 kside=2, conlev=0.99  
Line. 66 stop
```

Appendix C NuSMV Model of CSWI

This appendix contains the NuSMV model for the CSWI component described in Chapter 7.

```
MODULE main
IVAR
  input : {_opsel_on, _opsel_off, _oppos_open, _oppos_close,
sbosel, sbopos, none};
VAR
  output : {_sbosel_on, _sbosel_off, _sbopos_open,
_sbopos_close, opsel, oppos, none};
  state : {waiting, selecting, selected, opening, closing,
deselecting, unselecting};

ASSIGN
  init(input) := none;
  -- next(input) is unconstrained/non-deterministic

  init(output) := none;
  next(output) :=
    case
      state = waiting    & input = _opsel_on    : _sbosel_on    ;
      state = waiting    & input = _opsel_off    : _sbosel_off    ;
      state = selecting  & input = sbosel       : opsel         ;
      state = selected   & input = _opsel_on    : _sbosel_on    ;
      state = selected   & input = _opsel_off    : _sbosel_off    ;
;
      state = selected   & input = _oppos_open   : _sbopos_open   ;
;
      state = selected   & input = _oppos_close  :
_sbopos_close;
      state = opening    & input = sbopos       : _sbosel_off    ;
      state = closing    & input = sbopos       : _sbosel_off    ;
      state = deselecting & input = sbosel      : oppos         ;
      state = unselecting & input = sbosel      : opsel         ;
      1 : none;
```

```

    esac;

    init(state) := waiting;
    next(state) :=
        case
            state = waiting      & input = _opsel_on      : selecting ;
            state = waiting      & input = _opsel_off     : unselecting;
            state = selecting    & input = sbosel         : selected   ;
            state = selected     & input = _opsel_on      : selecting  ;
            state = selected     & input = _opsel_off     : unselecting;
            state = selected     & input = _oppos_open    : opening    ;
            state = selected     & input = _oppos_close   : closing    ;
            state = opening      & input = sbopos         : deselection;
            state = closing      & input = sbopos         : deselection;
            state = deselection  & input = sbosel         : waiting    ;
            state = unselecting  & input = sbosel         : waiting    ;
            1 : state;
        esac;

    SPEC EF(state = waiting)
    SPEC EF(state = selecting)
    SPEC EF(state = selected)
    SPEC EF(state = opening)
    SPEC EF(state = closing)
    SPEC EF(state = deselection)
    SPEC EF(state = unselecting)

    SPEC AG((state = waiting) & (input = _opsel_on) -> AX(output =
    _sbosel_on))
    SPEC AG((state = selected) & (input = _opsel_off) -> AX(output
    = _sbosel_off))
    SPEC AG((state = selected) & (input = _oppos_open) -> AX(output
    = _sbopos_open))
    SPEC AG((state = selected) & (input = _oppos_close) -> AX(out-
    put = _sbopos_close))

    SPEC !E[!(output = _sbosel_on) U (output = _sbopos_open)]

    -- the following claim is expected to fail
    SPEC AG(input = _opsel_on -> AG output = none)

```

Appendix D Switch Schematic

The schematic for the SEI switch is shown in its entirety in Figure 58. Figures 59 through 62 show the same schematic in larger scale split into four quadrants for easier viewing. To get a copy of the original schematic, contact Kurt Wallnau via email at kcw@sei.cmu.edu.

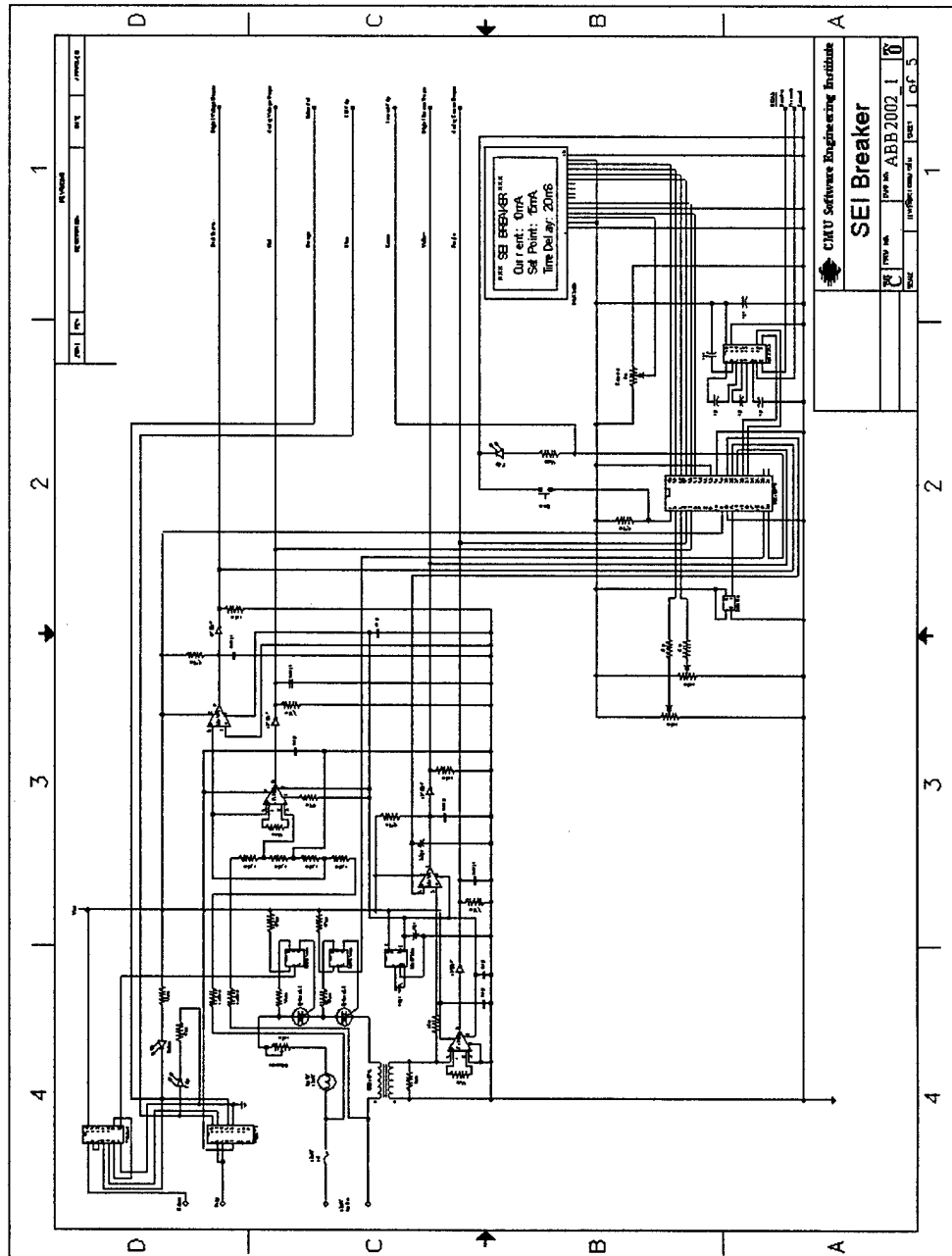

Figure 58: SEI Switch: Full Schematic

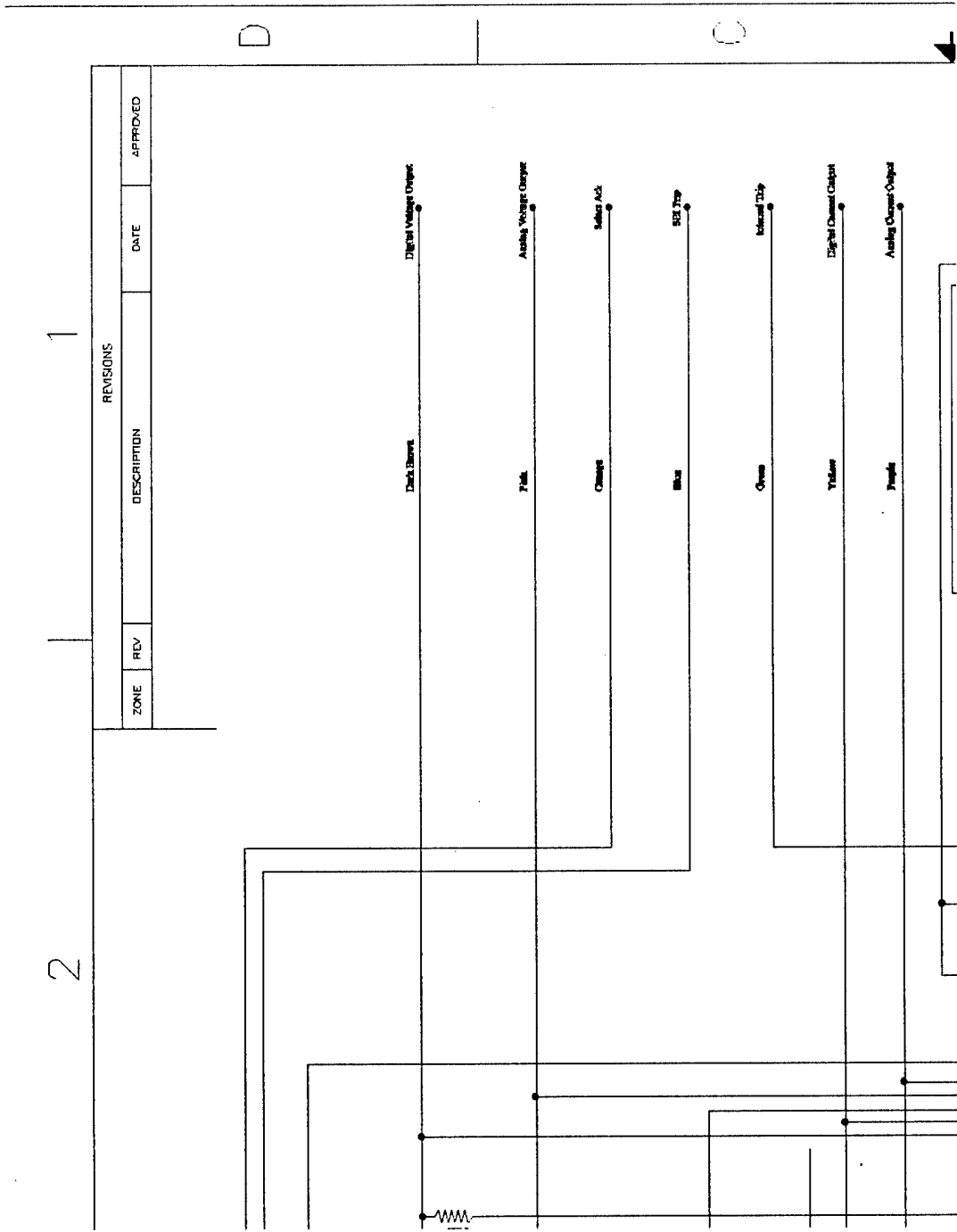

Figure 59: SEI Switch: Upper Right Quadrant

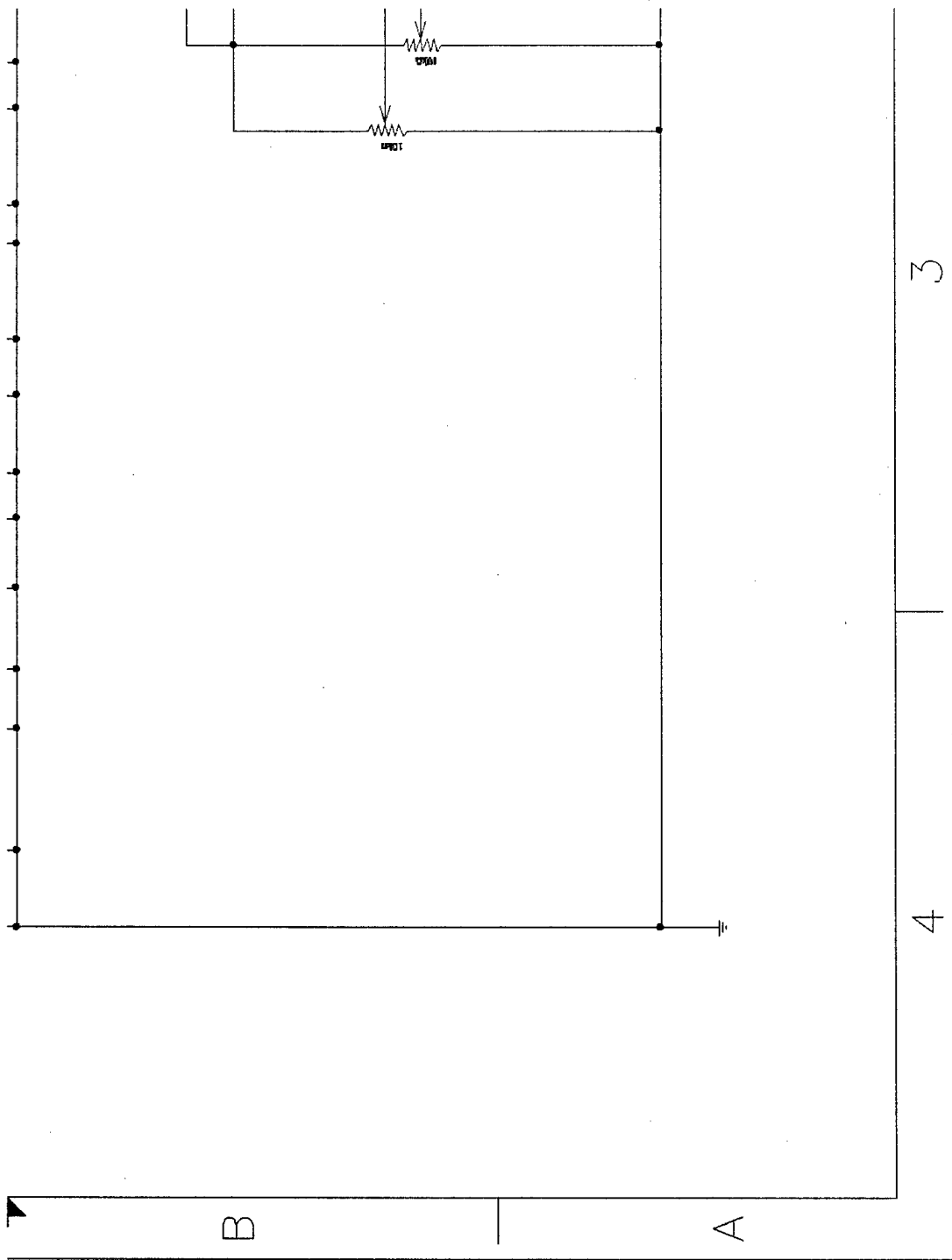

Figure 62: SEI Switch: Lower Left Quadrant

Acronym List

ABB	Asea Brown Boveri, Ltd.
ABB/CRC	Asea Brown Boveri, Ltd./Corporate Research Center
AIP	Aspect Integration Program
API	application program interface
COTS	commercial off-the-shelf
CPU	central processing unit
CTL	computational tree logic
DoD	Department of Defense
EMS	energy management system
FIFO	first in, first out
HP	hyper-period
IEC	International Electrotechnical Commission
IED	intelligent electronic device
I/O	input/output
LCM	least common multiple
LIFO	last in, first out
LN	logical node
LS-SDE	language-specific software development environment

LTL	linear temporal logic
MRE	magnitude of relative error
MS	milliseconds
NS	nanoseconds
OLE	object linking and embedding
OPC	OLE (object linking and embedding) for process control
OS	operating system
PACC	predictable assembly of certifiable components
PC	physical connection
PD	physical device
PECT	prediction-enabled component technology
RMA	rate monotonic analysis
RUP	Rational Unified Process
SAS	substation automation system
SCADA	supervisory control and data acquisition
SDE	software development environment
SEI	Software Engineering Institute
TBD	to be decided
UDP	Universal Datagram Protocol
UML	Unified Modeling Language
XML	Extensible Markup Language

Bibliography

URLs valid as of the publication date of this document

- [Aho 87]** Aho, A.; Sethi, R.; & Ullman, J. *Compilers: Principles, Techniques, and Tools*. Reading, MA: Addison-Wesley, 1987.
- [Allen 97]** Allen, R. "A Formal Approach to Software Architecture." PhD diss. (CMU-CS-97-144), Carnegie Mellon University, May 1997.
- [Bachmann 00]** Bachmann, F.; Bass, L.; Buhman, C.; Comella-Dorda, S.; Long, F.; Robert, J.; Seacord, R.; & Wallnau, K. *Volume II: Technical Concepts of Component-Based Software Engineering, 2nd Edition* (CMU/SEI-2000-TR-008, ADA379930). Pittsburgh, PA: Software Engineering Institute, Carnegie Mellon University, 2000. <<http://www.sei.cmu.edu/publications/documents/00.reports/00tr008.html>>.
- [Ball 02]** Ball, T. & Rajamani, S. K. "Automatically Validating Temporal Safety Properties of Interfaces," 103-122. *Proceedings of the Workshop on Model Checking of Software, LNCS 2057*. Toronto, Ontario, Canada, May 19-20, 2001. New York, NY: Springer-Verlag, 2002.
- [Barnett 01]** Barnett, M. & Schulte, W. "Spying on Components: A Runtime Verification Technique," 7-13. *Proceedings of the Workshop of Specification and Verification of Component-Based Systems (SAVCBS) at OOPSLA*. Tampa, Florida, October 14, 2001. New York, NY: Association for Computing Machinery, 2001. <<http://www.cs.iastate.edu/~leavens/SAVCBS/papers-2001/barnett-schulte.pdf>> or <<http://research.microsoft.com/foundations/savcbs.pdf>>.
- [Bass 98]** Bass, L.; Clements, P.; & Kazman, R. *Software Architecture in Practice*. Boston, MA: Addison-Wesley, 1998.
- [Buskins 02]** Buskins, V. *Social Networks and Trust*. Boston, MA: Kluwer Academic Publishers, 2002.

- [CDIF 97]** Electronic Industries Association. *CDIF CASE Data Interchange Format—Overview*. <<http://www.eigroup.org/cdif/electronic-extracts/OV-extract.pdf>> (1997).
- [Cimatti 00]** Cimatti, A.; Clarke, E.; Giunchiglia, F.; & Roveri, M. "NuSMV: A New Symbolic Model Verifier." *International Journal on Software Tools for Technology Transition* 2, 4 (April 2000): 410-425. <http://nusmv.irst.itc.it/NuSMV/papers/sttt_j/html/index.html>.
- [Clarke 99]** Clarke, E.; Grumberg, O.; & Peled, D. A. *Model Checking*. Cambridge, MA: MIT Press, Massachusetts Institute of Technology, 1999.
- [Clements 02a]** Clements, P. & Northrop, L. *Software Product Lines: Practices and Patterns*. Boston, MA: Addison-Wesley, 2002.
- [Clements 02b]** Clements, P.; Bachmann, F.; Bass, L.; Garlan, D.; Ivers, J.; Little, R.; Nord, R.; & Stafford, J. *Documenting Software Architectures: Views and Beyond*. Boston, MA: Addison-Wesley, 2002.
- [Davies 93]** Davies, J. *Specification and Proof in Real-Time CSP*. New York, NY: Cambridge University Press, 1993.
- [Fenton 97]** Fenton, N. E. & Pleeger, S. L. *Software Metrics A Rigorous and Practical Approach* (ISBN 1-85032-275-9). Boston, MA: PWS Publishing Company, 1997.
- [Gardiner 00]** Gardiner, P.; Goldsmith, M.; Hulance, J.; Jackson, D.; Roscoe, B.; & Scattergood, B. *Failures-Divergence Refinement: FDR2 User Manual*. Oxford, England: Formal Systems (Europe) Ltd., 2000.
- [Garlan 93]** Garlan, D. & Shaw, M. "An Introduction to Software Architecture, 1-39. *Proceedings of the 4th International Conference on Software Engineering and Knowledge Engineering, Advances in Software Engineering and Knowledge Engineering*. Capri, Italy, June 15-20, 1992. River Edge, NY: World Scientific Publishing Company, 1993.
- [Giannakopoulou 99]** Giannakopoulou, D. "Model Checking for Concurrent Software Architectures." PhD diss., Imperial College of Science, Technology, and Medicine, University of London, January, 1999.

- [Gluch 02]** Gluch, D.; Comella-Dorda, S.; Hudak, J.; Lewis, G.; Walker, J.; Weinstock, C.; & Zubrow, D. *Model-Based Verification: An Engineering Practice* (CMU/SEI-2002-TR-021, ADA407768). Pittsburgh, PA: Software Engineering Institute, Carnegie Mellon University, 2002. <<http://www.sei.cmu.edu/publications/documents/02.reports/02tr021.html>>.
- [Gorton 02]** Gorton, I. & Liu, A. "Software Component Quality Assessment in Practice: Successes and Practical Impediments," 555-558. *Proceedings of the 24th International Conference on Software Engineering*. Orlando, Florida, May 19-25, 2002. New York, NY: Association for Computing Machinery, 2002.
- [Hahn 91]** Hahn, G. & Meeker, W. *Statistical Intervals: A Guide for Practitioners*. New York, NY: John Wiley & Sons, Inc., 1991.
- [Havelund 00]** Havelund, K. & Pressburger, T. "Model Checking Java Programs Using Java PathFinder." *International Journal on Software Tools for Technology Transfer (STTT)* 2, 4 (April 2000): 366-381.
- [Hissam 02]** Hissam, S.; Moreno, G.; Stafford, J.; & Wallnau, K. "Packaging Predictable Assembly," 108-124. *Proceedings of the 1st ACM/IFIP Working Conference on Component Deployment* (Lecture Notes in Computer Science Volume 2370). Berlin, Germany, June 20-21, 2002. Berlin, Germany: Springer Verlag, 2002.
- [Hoare 85]** Hoare, C. A. R. *Communicating Sequential Processes*. Englewood Cliffs, NJ: Prentice Hall International, 1985.
- [Holzman 97]** Holzman, G. J. "The Model Checker Spin." *IEEE Transactions on Software Engineering* 23, 5 (May 1997): 279-295.
- [IEC 02]** International Electrotechnical Commission. *Communications Networks and Systems in Substations, Working Draft for International Standard IEC 61850-1..10*. Geneva, Switzerland: International Electrotechnical Commission, January, 2002.
- [Ivers 02]** Ivers, J.; Sinha, N.; & Wallnau, K. *A Basis for Composition Language CL* (CMU/SEI-2002-TN-026, ADA407797). Pittsburgh, PA: Software Engineering Institute, Carnegie Mellon University, 2002. <<http://www.sei.cmu.edu/publications/documents/02.reports/02tn026.html>>.

- [Kazman 00]** Kazman, R.; Klein, M.; & Clements, P. *ATAM: Method for Architecture Evaluation* (CMU/SEI-2000-TR-004, ADA382629). Pittsburgh, PA: Software Engineering Institute, Carnegie Mellon University, 2000. <<http://www.sei.cmu.edu/publications/documents/00.reports/00tr004.html>>.
- [Klein 93]** Klein, M.; Ralya, H.; Pollack, B.; & Obenza, R. *A Practitioner's Handbook for Real-Time Analysis: Guide to Rate Monotonic Analysis for Real-Time Systems*. Boston, MA: Kluwer Academic Press, 1993.
- [Kruchten 00]** Krutchen, P. *The Rational Unified Process An Introduction*, 2nd edition. Boston, MA: Addison-Wesley, 2000.
- [Lamport 77]** Lamport, L. "Proving the Correctness of Multiprocess Programs." *IEEE Transactions on Software Engineering SE 3*, 2 (March 1977): 125-143.
- [Li 02]** Li, P. L.; Shaw, M.; Stolarick, K.; & Wallnau, K. *The Potential for Synergy Between Certification and Insurance*. <<http://www.sei.cmu.edu/staff/kcw/icsr02.pdf>> (2002).
- [Magee 93]** Magee, J.; Dulay, N.; & Kramer, J. "Structured Parallel and Distributed Programs." *Software Engineering Journal 8*, 2 (March 1993): 73-82.
- [Magee 99]** Magee, J. & Kramer, J. *Concurrency State Models & Java Programs*. New York, NY: Wiley, 1999.
- [Mason 02]** Mason, D. "Probabilistic Analysis for Component Reliability Composition." *Proceedings of the 5th International Workshop on Component-Based Software Engineering: Benchmarks for Predictable Assembly*, in conjunction with the 24th International Conference on Software Engineering (ICSE2002). Orlando, Florida, May 19-20, 2002. <<http://www.sei.cmu.edu/pacc/CBSE5/Mason-cbse5-final.pdf>>.
- [Meeker 93]** Meeker, W. & Chow, I. *StInt—A Computer Program for Computing Statistical Intervals*. <<http://www.public.iastate.edu/~wqmeeker/StInt/StInt.pdf>> (1993).

- [Meyer 98]** Meyer, B.; Mingins, C.; & Schmidt, H. "Providing Trusted Components to the Industry." *Computer (IEEE)* 31, 5 (May 1998): 104-105.
- [Milner 89]** Milner, R. *Communication and Concurrency*. New York, NY: Prentice Hall, 1989.
- [Milner 99]** Milner, R. *Communicating and Mobile Systems: The π -Calculus*. New York, NY: Cambridge University Press, May 1999.
- [Moreno 02]** Moreno, G.; Hissam, S.; & Wallnau, K. "Statistical Models for Empirical Component Properties and Assembly-Level Property Predictions: Toward Standard Labeling." *Proceedings of the 5th International Workshop on Component-Based Software Engineering*, in conjunction with the 24th International Conference on Software Engineering (ICSE2002). Orlando, Florida, May 19-20, 2002. <<http://www.sei.cmu.edu/pacc/CBSE5/Moreno-cbse5-final.pdf>>.
- [Naumovich 00]** Naumovich, G. & Clarke, L. "Classifying Properties: An Alternative to the Safety-Liveness Classification," 159-168. *Proceedings of the Eighth International Symposium on the Foundations of Software Engineering*. San Diego, California, November 8-10, 2000. New York, NY: Association for Computing Machinery, 2000.
- [Plakosh 99]** Plakosh, D.; Smith, D.; & Wallnau, K. *Builder's Guide for Water-Beans Components* (CMU/SEI-99-TR-024, ADA373154). Pittsburgh, PA: Software Engineering Institute, Carnegie Mellon University, 1999. <<http://www.sei.cmu.edu/publications/documents/99.reports/99tr024/99tr024abstract.html>>.
- [Pnueli 85]** Pnueli, A. & Harel D. *On the Development of Reactive Systems* (Technical Report CS85-02). Rehovot, Israel: Weizmann Institute of Science, Department of Computer Science, 1985.
- [Preiss 01]** Preiss, O. & Wegmann, A. *Towards a Composition Model Problem Based on IEC61850*. <http://www.sei.cmu.edu/pacc/CBSE4_papers/PreissWegmann-CBSE4-4.pdf> (2001).
- [Prior 62]** Prior, Arthur N. *Formal Logic*, 2nd edition. Oxford, UK: Clarendon Press, 1962.

- [Rabinovich 00] Rabinovich, S. G. *Measurement Errors and Uncertainties*, 2nd edition (ISBN 0-387-98835-1). New York, NY: Springer-Verlag, 2000.
- [Reed 88] Reed, G. M. "A Uniform Mathematical Theory for Real-Time Distributed Computing." PhD diss., Oxford University, 1988.
- [Roscoe 98] Roscoe, A. W. *The Theory and Practice of Concurrency*. New York, NY: Prentice Hall, 1998.
- [Rumbaugh 00] Rumbaugh, J.; Jacobson, I.; & Booch, G. *The Unified Modeling Language Reference Manual*. Reading, MA: Addison-Wesley Longman, 2000.
- [Schubert 99] Schubert, P. & Ginsburg, M. "Virtual Communities of Transaction: The Role of Personalization in Electronic Commerce," 646-663. *12th International Bled Electronic Commerce Conference: "Global Networked Organizations."* Bled, Slovenia, June 7 - 9, 1999. Bled, Slovenia: Moderna Organizacija, 1999.
- [Schwetman 78] Schwetman, H. "Hybrid Simulation Models of Computer Systems." *Communications of the ACM* 21, 9 (September 1978): 718-723.
- [Sharygina 02] Sharygina, N. "Model Checking of Software Control Systems." PhD diss., The University of Texas at Austin, 2002.
- [Stafford 01] Stafford, J. & Wallnau, K. *Is Third-Party Certification Necessary?* <http://www.sei.cmu.edu/pacc/CBSE4_papers/StaffordWallnau-CBSE4-22.pdf> (2001).
- [Stafford 02] Stafford, J. & McGregor, J. D. "Issues in Predicting the Reliability of Composed Components." *Proceedings of the 5th International Workshop on Component-Based Software Engineering*, in conjunction with the 24th International Conference on Software Engineering (ICSE2002). Orlando, Florida, May 19-20, 2002. <<http://www.sei.cmu.edu/pacc/CBSE5/StaffordMcGregor-cbse5.pdf>>.
- [Szyperski 97] Szyperski, C. *Component Software: Beyond Object Oriented Programming*. Reading, MA: Addison-Wesley, 1997.

- [Taylor 94]** Taylor, B. & Kuyatt, C. *Guidelines for Evaluating and Expressing the Uncertainty of NIST Measurement Results* (microform, NIST Technical Note 1297). Gaithersburg, MD: U.S. Department of Commerce, Technology Administration, National Institute of Standards and Technology, 1994.
- [Theil 02]** Thiel, S. & Hein, A. "Modeling and Using Product Line Variability in Automotive Systems." *IEEE Software, Special Issue on Software Product Lines 19*, 4 (July/August 2002): 66-72.
- [van Glabbeek 01]** van Glabbeek, R. Part 1, Ch. 1, "The Linear Time-Branching Time Spectrum I. The Semantics of Concrete, Sequential Processes," 3-99. *Handbook of Process Algebra* (ISBN 0-444-82830-3). New York, NY: Elsevier, 2001.
<<http://adam.wins.uva.nl/~alban/Handbook-free>>.
- [van Ommering 02]** van Ommering, R. Part 5, Ch. 12, "The Koala Component Model," 223-236. *Building Reliable Component-Based Software Systems*. Boston, MA: Artech House, 2002.
- [Wallnau 02]** Wallnau, K.; Hissam, S.; & Seacord, R. *Building Systems from Commercial Components*. Boston, MA: Addison-Wesley, 2002.
- [Walpole 89]** Walpole, R. E. & Myers, R. H. *Probability and Statistics for Engineers and Scientists*. New York, NY: MacMillan Publishing Company, 1989.
- [Woodcock 97]** Woodcock, J. & Davies, J. *Using Z: Specification, Refinement, and Proof*. New York, NY: Prentice Hall, 1997.

REPORT DOCUMENTATION PAGE

Form Approved
OMB No. 0704-0188

Public reporting burden for this collection of information is estimated to average 1 hour per response, including the time for reviewing instructions, searching existing data sources, gathering and maintaining the data needed, and completing and reviewing the collection of information. Send comments regarding this burden estimate or any other aspect of this collection of information, including suggestions for reducing this burden, to Washington Headquarters Services, Directorate for Information Operations and Reports, 1215 Jefferson Davis Highway, Suite 1204, Arlington, VA 22202-4302, and to the Office of Management and Budget, Paperwork Reduction Project (0704-0188), Washington, DC 20503.

10. AGENCY USE ONLY (leave blank)		11. REPORT DATE September 2002	12. REPORT TYPE AND DATES COVERED Final
13. TITLE AND SUBTITLE Predictable Assembly of Substation Automation Systems: An Experiment Report		14. FUNDING NUMBERS C — F19628-00-C-0003	
15. AUTHOR(S) Scott Hissam, John Hudak, James Ivers, Mark Klein, Magnus Larsson, Gabriel Moreno, Linda Northrop, Daniel Plakosh, Judith Stafford, Kurt Wallnau, William Wood		17. PERFORMING ORGANIZATION REPORT NUMBER CMU/SEI-2002-TR-031	
16. PERFORMING ORGANIZATION NAME(S) AND ADDRESS(ES) Software Engineering Institute Carnegie Mellon University Pittsburgh, PA 15213		19. SPONSORING/MONITORING AGENCY REPORT NUMBER ESC-TR-2002-031	
18. SPONSORING/MONITORING AGENCY NAME(S) AND ADDRESS(ES) HQ ESC/XPK 5 Eglin Street Hanscom AFB, MA 01731-2116		20. SUPPLEMENTARY NOTES	
12.a DISTRIBUTION/AVAILABILITY STATEMENT Unclassified/Unlimited, DTIC, NTIS		12.b DISTRIBUTION CODE	
13. ABSTRACT (maximum 200 words) The Predictable Assembly from Certifiable Components (PACC) Initiative at the Software Engineering Institute (SEI SM) is developing methods and technologies for predictable assembly. A software development activity that builds systems from components is <i>predictable</i> if the runtime behavior of an assembly of components can be predicted from known properties of components and their patterns of interactions (connections), and if these predictions can be <i>objectively validated</i> . A component is <i>certifiable</i> if these known properties can be obtained or validated by independent third parties. The SEI's technical approach to PACC rests on prediction-enabled component technology (PECT). At the highest level, PECT is a scheme for systematic and repeatable integration of software component technology, software architecture technology, and design analysis and verification technology. This report describes the results of an <i>exploratory</i> PECT prototype for substation automation, an application area in the domain of power generation, transmission, and management. This report focuses primarily on the methodological aspects of PECT; the prototype itself was only a means to expose and illustrate the PECT method.			
14. SUBJECT TERMS component-based software, predictable assembly, component technology, certification, component framework, CBSE, prediction-enabled component technology		15. NUMBER OF PAGES 164	16. PRICE CODE
17. SECURITY CLASSIFICATION OF REPORT UNCLASSIFIED	18. SECURITY CLASSIFICATION OF THIS PAGE UNCLASSIFIED	19. SECURITY CLASSIFICATION OF ABSTRACT UNCLASSIFIED	20. LIMITATION OF ABSTRACT UL