

Collection of Video Images and Navigation Data for use in a Kalman Filter and Evaluation of Video Images for Post- flight Mission Reconstruction

“PROJECT PEEPING TALON”

Michael G. Giebner, Capt, USAF
Project Manager / Project Flight Test Engineer

William E. Peris, Maj, USAF
Project Test Pilot

Charles K. Havasy, Maj, USAF
Project Flight Test Engineer

Jean Bilger, Maj, French AF
Project Test Navigator

Clifton G. Janney, Capt, USAF
Project Test Pilot

Ron W. Schwing, Capt, USAF
Project Flight Test Engineer

Stephen P. H. Frank, Capt, USAF
Project Test Pilot

FINAL REPORT

December 2002

Approved for public release; distribution unlimited.

20030304 002

**USAF TEST PILOT SCHOOL
AIR FORCE FLIGHT TEST CENTER
EDWARDS AIR FORCE BASE, CALIFORNIA
AIR FORCE MATERIEL COMMAND
UNITED STATES AIR FORCE**

This Technical Information Memorandum (Project PEEPING TALON) was prepared and submitted under Job Order Number M02C1200 by the Commandant, USAF Test Pilot School, Edwards AFB, California 93524.

Prepared by:

This report has been reviewed and is approved for publication:

Date:

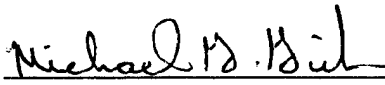

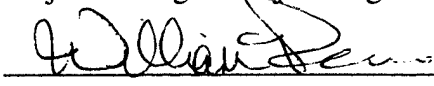
MICHAEL G. GIEBNER
Captain, USAF
Project Manager/ Project Flight Test Engineer

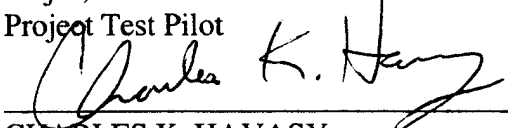

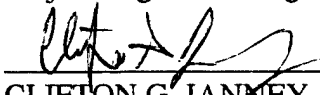
WILLIAM E. PERIS
Major, USAF
Project Test Pilot



CHARLES K. HAVASY
Major, USAF
Project Flight Test Engineer

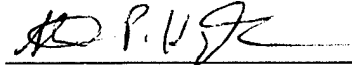

CLIFTON G. JANNEY
Captain, USAF
Project Test Pilot

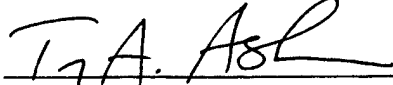

RON W. SCHWING
Captain, USAF
Project Flight Test Engineer

JEAN V. BILGER
Major, French AF
Project Test Navigator

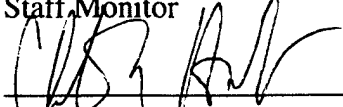
STEPHEN P. H. FRANK
Captain, USAF
Project Test Pilot

TROY ASHER
Major, USAF
Staff Monitor

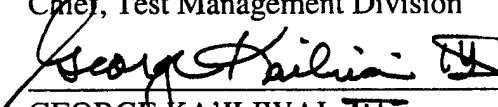
CHRIS HAMILTON
Major, USAF
Chief, Test Management Division

GEORGE KA'ILIWAI III
Colonel, USAF
Commandant, USAF TPS

REPORT DOCUMENTATION PAGE

Form Approved
OMB No. 0704-0188

Public reporting burden for this collection of information is estimated to average 1 hour per response, including the time for reviewing instructions, searching existing data sources, gathering and maintaining the data needed, and completing and reviewing this collection of information. Send comments regarding this burden estimate or any other aspect of this collection of information, including suggestions for reducing this burden to Department of Defense, Washington Headquarters Services, Directorate for Information Operations and Reports (0704-0188), 1215 Jefferson Davis Highway, Suite 1204, Arlington, VA 22202-4302. Respondents should be aware that notwithstanding any other provision of law, no person shall be subject to any penalty for failing to comply with a collection of information if it does not display a currently valid OMB control number. **PLEASE DO NOT RETURN YOUR FORM TO THE ABOVE ADDRESS.**

1. REPORT DATE (DD-MM-YYYY) 13-12-2002		2. REPORT TYPE Final		3. DATES COVERED (From - To) 17-01-2002 to 13-12-2002	
4. TITLE AND SUBTITLE Collection of Video Images and Navigation Data for use in a Kalman Filter and Evaluation of Video Images for Post-flight Mission Reconstruction.				5a. CONTRACT NUMBER	
				5b. GRANT NUMBER	
				5c. PROGRAM ELEMENT NUMBER	
6. AUTHOR(S) Michael G. Giebner, Captain, USAF Charles Havasy, Maj, USAF Clifton Janney, Capt, USAF Steve Frank, Capt, USAF William E. Peris, Maj, USAF Jean Bilger, Maj, French AF Ron Schwing, Capt, USAF				5d. PROJECT NUMBER	
				5e. TASK NUMBER	
				5f. WORK UNIT NUMBER	
7. PERFORMING ORGANIZATION NAME(S) AND ADDRESS(ES) USAF Test Pilot School 220 S. Wolfe Ave. Edwards AFB, CA 93524				8. PERFORMING ORGANIZATION REPORT NUMBER AFFTC-TIM-02-08	
9. SPONSORING / MONITORING AGENCY NAME(S) AND ADDRESS(ES) Air Force Institute of Technology Dept of Electrical Engineering Wright-Patterson AFB, OH 45433-7765 Air Force Research Laboratory Munitions Directorate Eglin AFB, FL 32542-6810				10. SPONSOR/MONITOR'S ACRONYM(S)	
				11. SPONSOR/MONITOR'S REPORT NUMBER(S)	
12. DISTRIBUTION / AVAILABILITY STATEMENT Approved for public release; distribution unlimited.					
13. SUPPLEMENTARY NOTES CA: Air Force flight Test Center Edwards AFB CA CC: 012100					
14. ABSTRACT The primary purpose of this project was to collect navigation and video data for use in a navigational Kalman filter. The secondary purpose of this project was to gather and analyze in-flight video images for post-flight mission reconstruction and terrain feature recognition. The test was flown in a T-38 aircraft modified with a GPS-aided inertial navigation reference system, Ashtech GPS receiver, two video cameras, a video recorder, and a cockpit video display. The primary test objective to collect navigation and video data was met. The secondary test objective to collect and analyze in-flight video images for post-flight reconstruction and terrain feature recognition was met. The cameras were marginally useful for terrain feature recognition (rated 3 on a scale of 1 to 5 with 5 being the best) and largely useful for mission reconstruction (rated 4 on a scale of 1 to 5 with 5 being the best). This test was conducted as a joint venture between USAF TPS, Ball Aerospace & Technologies Corp, Vision Systems International and the Air Force Institute of Technology.					
15. SUBJECT TERMS Kalman Filter INS (Inertial Navigation System) GPS (Global Positioning System) T-38 Aircraft					
16. SECURITY CLASSIFICATION OF:			17. LIMITATION OF ABSTRACT SAR	18. NUMBER OF PAGES 40	19a. NAME OF RESPONSIBLE PERSON Capt Michael G. Giebner
a. REPORT UNCLASSIFIED	b. ABSTRACT UNCLASSIFIED	c. THIS PAGE UNCLASSIFIED			19b. TELEPHONE NUMBER (include area code) 661-277-3000

Standard Form 298 (Rev. 8-98)
Prescribed by ANSI Std. Z39.18

AQMD3-05-1163

Preface

This technical information memorandum presents the procedures, concepts and results from the PEEPING TALON test project. The United States Air Force Test Pilot School (USAF TPS) PEEPING TALON test team conducted the test from the Air Force Flight Test Center, Edwards Air Force Base, California. The test was sponsored by the USAF TPS, Ball Aerospace, Vision Systems International and the Air Force Institute of Technology.

The PEEPING TALON Test Team would like to thank the following individuals for their outstanding contributions to the test effort. Jeff Brooks, the crew chief for aircraft T-38 65-10325, went well above and beyond that required for completion of the PEEPING TALON flight test project. Jeff was energetic and willing to aid the test team by performing duties outside those normally performed by an aircraft crew chief. This test would not have run as smoothly as it did without his help. Randy Glass, USAF Test Pilot School instrumentation technician, not only provided excellent support during the PEEPING TALON flight test project, but also contributed many good ideas to make the test run smoother and to solve some of the technical challenges faced by the test team. He helped generate the target for the camera evaluation and provided a laser pointer to aid in properly aligning the camera with the target. This greatly quickened the camera calibration process and made the process much easier.

Executive Summary

This Technical Information Memorandum presents the procedures, concepts and results from the PEEPING TALON test project. The primary purpose of this project was to collect navigation and video data for use in a navigational Kalman filter. The secondary purpose of this project was to gather and analyze in-flight video images for post-flight mission reconstruction and terrain feature recognition.

Testing was conducted at Edwards Air Force Base, California, from 30 Sep 02 to 1 Nov 02 using Edwards AFB ranges and surrounding areas. Twelve test missions (thirteen aircraft sorties) were flown for a total of 14.5 flight hours. This test was conducted as a joint venture between USAF TPS, Ball Aerospace & Technologies Corp, Vision Systems International and the Air Force Institute of Technology.

The test was flown in a T-38 aircraft modified with a GPS-aided inertial navigation reference system, an Ashtech GPS receiver, two video cameras, a video recorder, and a cockpit video display. Video images from forward and side view cameras were recorded using on-board digital recording equipment.

The primary test objective to collect navigation and video data was met. Valid data from seven sorties were required to meet the objective and data were valid for eight sorties.

The secondary test objective to collect and analyze in-flight video images for post-flight reconstruction and terrain feature recognition was met. The cameras were marginally useful for terrain feature recognition (rated 3 on a scale of 1 to 5 with 5 being the best) and largely useful for mission reconstruction (rated 4 on a scale of 1 to 5 with 5 being the best).

TABLE OF CONTENTS

Preface.....	iv
Executive Summary	v
Table of Contents	vi
List of Illustrations	vii
List of Tables	viii
Introduction.....	1
General.....	1
Background.....	1
Test Item Description.....	1
Test Objectives.....	3
Test and Evaluation.....	5
General.....	5
Collection of Navigation Data	5
Results & Analysis.....	6
Conclusions.....	6
Collection and Evaluation of Video Images	7
Results & Analysis.....	8
Conclusions.....	16
Conclusions.....	19
References.....	20
Appendix 1: CAMERA Preflight Summary	21
Appendix 2: Test Matrix	23
Appendix 3: Post-Flight Video Utility Rating Scale	25
Appendix 4: List of Abbreviations, Acronyms and Symbols.....	28
Distribution List.....	31

LIST OF ILLUSTRATIONS

Figure 1: PEEPING TALON T-38A Test Configuration	2
Figure 2: Target Board.....	8
Figure 3: Overall TFR.....	9
Figure 4: Overall MER	9
Figure 5: TFR Day	10
Figure 6: MER Day.....	11
Figure 7: TFR Night.....	11
Figure 8: MER Night	12
Figure 9: TFR Dusk/Dawn.....	13
Figure 10: MER Dusk/Dawn	13
Figure 11: TFR High Altitude.....	14
Figure 12: TFR Low Altitude	15
Figure 13: MER High Altitude	15
Figure 14: MER Low Altitude.....	16

LIST OF TABLES

Table 1: Navigation Data Requirements.....	5
Table 2: Navigation Data Results	6
Table 3: Rating Criteria and Definitions.....	7
Table 4: General Usefulness Rating Results.....	10

INTRODUCTION

General

The PEEPING TALON test program collected navigation and video data for later analysis by the project manager as part of his Masters thesis (Reference 1) for the Air Force Institute of Technology (AFIT). Additional video images were collected for Ball Aerospace and Vision Systems International. These images were qualitatively evaluated to determine their usefulness in post-flight mission reconstruction and terrain feature recognition. AFIT and the Munitions Directorate, Air Force Research Lab (AFRL), Eglin AFB, FL sponsored the navigation portion of this program. This test program was directed by the Commandant, USAF Test Pilot School (TPS) under Job Order Number (JON) M02C1200. Testing was conducted in ranges R-2508, W-289 and W-412 from 30 Sep 02 to 01 Nov 02. Thirteen total sorties were flown, accumulating 14.5 flight hours.

Background

The test program originated with the program manager during his course of study at AFIT in the fields of Control/Guidance & Navigation. The Master's thesis goal was to incorporate visual measurements into a navigation Kalman filter to determine if there was a measurable increase in accuracy. It was of secondary interest to determine the accuracy with which the Kalman filter could determine the location of the visual targets (latitude and longitude). No visual system was required at AFIT during the development of the Kalman filter algorithm. The USAF Test Pilot School was aware this test was approaching and was considering a limited evaluation of a low-light camera manufactured by Ball Aerospace. The camera system was satisfactory so the two projects were combined. The camera system would take video that could be used to obtain the required visual measurements for the Kalman filter, while the PEEPING TALON test team would also conduct a limited evaluation of the Ball Aerospace camera.

Test Item Description

A T-38A aircraft, tail number 65-10325, was modified to support the PEEPING TALON test program. The test system included navigation, video, and recording components. It consisted of a GPS-Aided Inertial Navigation Reference system (GAINR), an Ashtech GPS receiver, two model 71A video cameras, a liquid crystal display (LCD) cockpit monitor, and a digital recording system. See Figure 1 for the test configuration diagram.

The GAINR system consisted of an Embedded GPS/INS (EGI), a Pre-Flight Panel (PFP), a Cockpit Control Panel (CCP), and an Intelligent Flash-memory Solid State Recorder (IFSSR). The GAINR recorded Inertial Measurement Unit (IMU) raw data (Δv and $\Delta \theta$) at a 256 Hz rate and a blended EGI position solution at a 64 Hz rate to an internal data card.

The Ashtech Z-Surveyor was a 12-channel, dual frequency GPS receiver with a built-in battery and removable PC memory card. This receiver was capable of providing raw GPS signal data on the internal data card for post-processing. These data were stored at a 2 Hz rate.

Both the forward and side cameras were Ball Aerospace cameras, Model 71A, ruggedized all-light level, high-performance, Gated Intensified Charge Coupled Device monochrome cameras. These cameras used a 3rd generation intensifier coupled to a 768 (H) x 484 (V) pixel interline charge coupled device image sensor. The analog video output contained 525 lines at a field rate of 60 Hz, frame rate of 30 Hz, with 2:1 positive interlace. The cameras operated from 28 volts direct current with a power consumption of less than 6 watts. Camera dimensions were 5 x 2.5 x 2 inches (L x H x W) and each weighed 1.1 pounds.

The video monitor for the front seat was a 5-in. Transvideo International Rainbow II LCD Monitor. The monitor was mounted on the front cockpit glare shield. The video selector switch located in the front cockpit controlled which camera was displayed on the monitor and recorded on the video recorder. Video was recorded on a Sony GV-D300 digital videocassette recorder located in the front cockpit.

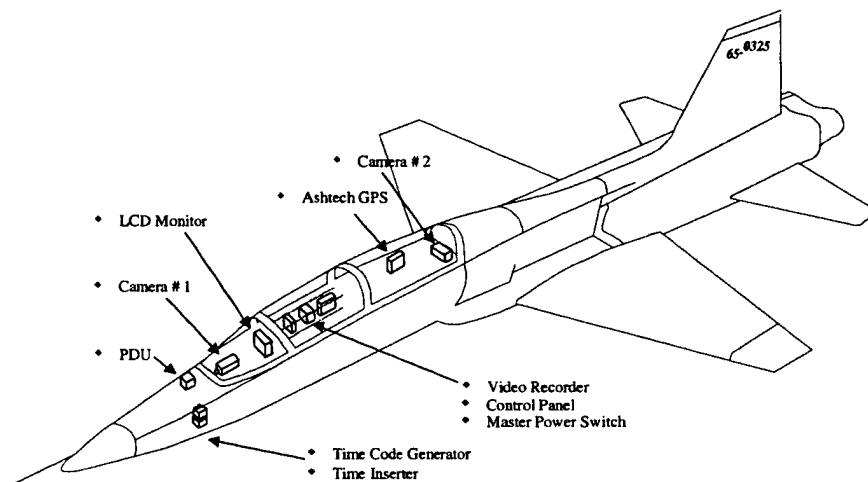

Figure 1: PEEPING TALON T-38A Test Configuration

The GPS time code generator, Datum model #9390-3000, received the GPS signal from the externally mounted GPS antenna and converted it to a digital format for the video time code inserter.

The video time code inserter, Datum model #9559-835, received GPS data from the GPS time code generator and the video signal from the selected camera. The video time code inserter combined these two data streams to provide a single output, which was a video picture with GPS time in the bottom right hand corner of the video image. This enabled the test team to determine the precise GPS time when each frame of video was recorded.

A camera selector switch located in the front cockpit was used to select which camera recorded to the digital video recorder. A second switch allowed for the selection of normal or anti-blooming modes of camera operation.

Test Objectives

The primary objective of the PEEPING TALON test program was to record data from a GAINR, Ashtech GPS receiver and forward/side-looking cameras. The navigational computation required five minutes of continuous video images of a ground target. Additionally, the GAINR recorded time, space, position information during this period. Valid Ashtech, GAINR and video data were required from seven sorties to meet the primary test objective.

The secondary objective was to record video data from both the forward-looking and side-looking cameras and to collect pilot comments and ratings for qualitative evaluation of the cameras' day-night imaging capability under the normal and anti-blooming technology (ABT) modes of operation. These comments related to the utility of the recorded images for post-flight analysis of terrain feature recognition and mission reconstruction. The required flight conditions were as follows:

1. Takeoff
 - a. Single ship
 - b. Interval
2. Low altitude flight (Day, Night, Near Sunrise, Near Sunset)
 - a. Over land (Low-level route and Edwards AFB Tower Flyby Pattern)
 - b. Over water (Day, Night, and Near Sunset only)
3. High altitude flight (Day and Night)
 - a. Over land
 - b. Over water
4. Air-to-Air Tactical Maneuvering (Advanced Rejoin Maneuvers)
5. Level Flight over a Target Board
 - a. Day
 - b. Night
 - c. Near Sunrise (eastbound)
 - d. Near Sunset
6. Descent
7. Landing

In addition, the ability of the camera to detect a ground-based infrared beacon during flight was evaluated.

All test objectives were met.

THIS PAGE INTENTIONALLY LEFT BLANK

TEST AND EVALUATION

General

The PEEPING TALON test program used on-board navigation systems and newly developed imaging equipment to record in-flight video images of ground targets. The digital video data were collected for subsequent use in a navigation Kalman filter. Additionally, video images from the forward and side looking camera were recorded under multiple lighting conditions and varied terrain features for use by Ball Aerospace & Technologies Corp. The cameras incorporated an anti-blooming mode which was turned off intermittently during the flight for comparison purposes.

Collection of Navigation Data

The primary objective of the PEEPING TALON test program was to record data from a GAINR, Ashtech GPS receiver and forward/side-looking cameras. To achieve this objective, a navigation portion of each sortie was flown in an orbit over a ground target area. Several different altitudes, airspeeds and side-looking camera field-of view's (FOV) were flown during the test. For specific camera and FOV combinations see Appendix 1. Navigation data requirements are listed in Table 1. This objective was met.

Table 1: Navigation Data Requirements

Data Type	Minimum Data Rate
GPS Aided Inertial Navigation Reference (GAINR) Inertial Measurement Unit (IMU) ΔV and $\Delta\theta$	At least 250 Hz
GAINR Embedded GPS/INS (EGI) Position	At least 32 Hz
Ashtech GPS Pseudoranges	30 data records per minute
Video Images	At least one image of the selected target(s) every ten seconds for a five minute period

The Edwards Range Group downloaded GAINR EGI and IMU data from the aircraft data card. The data were then converted into a binary format and given to the PEEPING TALON test team. The binary data were converted into a numerical format usable by the Matlab[®] software program. The EGI position data were compared to the profile flown and the Ashtech GPS position data to verify the data were good (ground tracks were compared visually). The EGI position data were then processed through a Matlab[®] routine to verify there were at least 32 data records per second. The IMU data start and stop times were compared to the start and stop times of the EGI position data and the Ashtech GPS data to ensure the times were correct. The IMU data were then run through a Matlab[®] routine to ensure there were at least 250 data records per second.

GPS data were downloaded from the Ashtech GPS receiver memory card. The "b" file contained raw GPS data and the "e" file contained GPS ephemeris data. These files were then processed through a Matlab[®] routine to verify the GPS data were good. This was accomplished by converting the GPS pseudoranges contained in the "b" file into position information to

compare the profile flown to the EGI position data. The raw GPS pseudoranges were then processed through a Matlab[®] routine to verify there were at least 30 data records every minute during the flight. Satellite ephemeris data were converted from the “e” file with the “e_to_eph.exe” executable file.

Video images were collected by flying a circular pattern over a ground target area. A ten-minute pattern was planned to ensure five-minutes of valid data were collected. The video was viewed after the flight to verify that a ground area with sufficient detail was visible once every ten-seconds for a five-minute period.

Results & Analysis

The required data were recorded for 12 sorties. Specific sortie results are presented in Table 2. Sorties 1 and 2 were initially labeled as bad due to the GAINR initializing in the wrong location. The Edwards Range Group processed the raw data through their MOSES Kalman filter algorithm to correct this error, which produced usable data. Sortie 6a was terminated early due to an in-flight emergency before the five-minutes of navigation image data could be collected. Sortie 6b was a re-fly of sortie 6a and was bad because the GAINR did not record any data. The aircraft was taxied before the GAINR aligned completely and the system did not align during taxi (the PEEPING TALON program manager was assured prior to start of flight test that the system would align during taxi). Sortie 9 was bad due to the Ashtech GPS pseudoranges being corrupted (unknown reason). Sortie 10 data were not usable due to the side-looking camera being out of focus.

Table 2: Navigation Data Results

Sortie Number	IMU	EGI Position	GPS Pseudoranges	Image	Sortie Objective Met
1	Good	Good	Good	Good	Yes
2	Good	Good	Good	Good	Yes
3	Good	Good	Good	Good	Yes
4	Good	Good	Good	Good	Yes
5	Good	Good	Good	Good	Yes
6a ¹	Good	Good	Good	Bad	No
6b ²	Bad	Bad	Good	Good	No
7	Good	Good	Good	Good	Yes
8	Good	Good	Good	Good	Yes
9 ³	Good	Good	Bad	Good	No
10 ⁴	Good	Good	Good	Bad	No
11	Good	Good	Good	Good	Yes

¹ An in-flight emergency precluded collecting any data for the navigation portion of the sortie

² GAINR system did not work properly (the error was not recoverable)

³ GPS pseudoranges were corrupted and not recoverable (unknown reason)

⁴ Side camera was out of focus

Conclusions

The primary test objective was met despite deficiencies in the navigation systems, which produced unusable data on several of the sorties. The unusable data from the sorties listed in

Table 2 were either due to circumstances where the system was capable of meeting the requirements but was not allowed to collect the data (sortie 6a), due to a navigation system malfunction (sorties 6b and 9) or human error (sortie 10). The reasons for these navigation system malfunctions could not be determined due to insufficient data to narrow the cause to any particular component.

Collection and Evaluation of Video Images

The secondary objective of the test was to record video data from both the forward-looking and side-looking cameras. Pilot comments and ratings were collected for the video images for qualitative evaluation of the cameras' day-night imaging capability under the normal and anti-blooming technology (ABT) modes of operation. The capability of the camera to detect an infrared beacon was also evaluated. This objective was met.

PEEPING TALON test missions were flown to collect recorded video images under a large variety of lighting conditions, terrain features, altitudes, and mission tasks. Video was recorded continuously on each mission from immediately before takeoff until shortly after landing. During the flight, the pilot alternately selected the forward-looking and side-looking cameras and occasionally disabled the anti-blooming technology. The specific conditions in which video data were recorded are outlined in Appendix 2. A sufficient quantity of video data were collected at each of the desired test conditions to allow the test team to evaluate the images in accordance with the test objectives.

To evaluate the usefulness of the video images, the aircrew used the following methodology. During post-flight review of the video images, aircrew determined the utility of the recorded images for recognizing terrain features and recreating mission events. In order to standardize the evaluations, crews defined terrain feature recognition as the ability to discern the shape, size, and visible detail of a given feature. Mission event reconstruction was defined as the ability of the crew to determine what maneuvers the aircraft was performing, where the aircraft was located relative to familiar terrain, and at what altitude above ground level the aircraft was flying. Aircrew provided qualitative comments and utility ratings pertaining to each of these two evaluation criteria. The utility ratings were discrete numerical ratings from 1 to 5, in which a 1 rating indicated the recorded video was "**Completely Useless**" for the task, and a 5 rating indicated "**Completely Useful**" video images. A complete description of the ratings scales used to conduct the evaluation is included in Table 3. An example crew comment and rating sheet is included in Appendix 3.

Table 3: Rating Criteria and Definitions

Rating	Criteria	Definition
1	Completely Useless	Task cannot be performed. Task not accomplished due to image deficiencies.
2	Largely Useless	Major problems encountered. Task accomplished with great difficulty or accomplished poorly. Significant degradation of task due to image quality.
3	Marginally Useful	The task can be accomplished with some difficulty. Image meets minimal requirements to accomplish task.
4	Largely Useful	The task can be completed as intended. Image improvements would make task easier or more efficient.
5	Completely Useful	Task accomplished satisfactorily. No image improvement required.

In their evaluation of terrain feature recognition, pilots compared the detail visible on the recorded video image to the detail visible to the unaided eye while in flight. In order to aid in determining what terrain features were visible to the crew in flight, the team recorded comments using the aircraft intercom system. These comments included statements describing the image on the cockpit camera display, but display capabilities were not considered in the evaluation of video images.

For missions during night, low light, or limited visibility, pilots specifically commented on any features that were not visible to the unaided eye, but were visible on the recorded video. These comments included an analysis of the amount of detail visible on the recorded image, and a subjective, experience-based determination as to whether sufficient detail was present to allow a pilot to navigate or re-create mission events using an image of the quality that was recorded.

On selected missions, the crew flew a 1,000 ft AGL level pass over the visual target board shown in Figure 2. Over-flights were conducted using both the forward and side-looking cameras with pattern procedures that allowed the aircraft to have a 3-5 nm approach to the target board when using the forward camera, and a high line-of-sight pass when using the side-looking camera. On the side-looking passes, actual aircraft distance from the target varied greatly based on pilot technique. Actual slant range to the target varied from approximately 1,200 to 3,000 ft. During two of the night missions, a small infrared beacon was placed near the target board to evaluate the camera's ability to detect the beacon. Aircrew used TACAN instruments and handheld GPS to estimate the aircraft range from the target board during each pass.

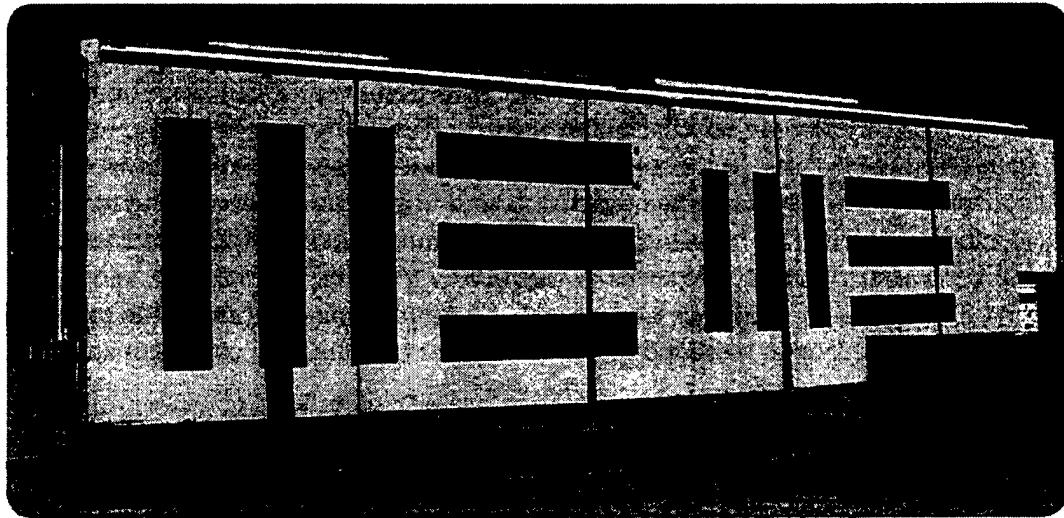

Figure 2: Target Board

Results & Analysis

The ability to discern terrain and reconstruct mission tasks using the Ball Aerospace camera video was evaluated in a number of conditions and altitudes using the front and side cameras. The results of this evaluation will be presented first including all data, then broken down by lighting condition and altitude. In each case, video quality ratings and comments will be presented as they pertain to Terrain Feature Recognition (TFR) and Mission Event

Reconstructions (MER). The numerical ratings were discrete and do not lend themselves to average ratings, so analysis was based on the rating most frequently given, and the flight conditions that produced variations from that rating. The rating scales utilized are listed in Table 3. The front and side camera performance was not noticeably different and all discussion will apply to both cameras.

Overall Performance

Considering all conditions, the camera video quality was rated “Marginally Useful” for terrain feature recognition (42% of the ratings were 3). The camera was considered “Largely Useful” for mission event reconstruction looking at tasks and conditions evaluated (44% of the ratings were 4). See Figure 3 and Figure 4 for a summary of the ratings for all events and conditions.

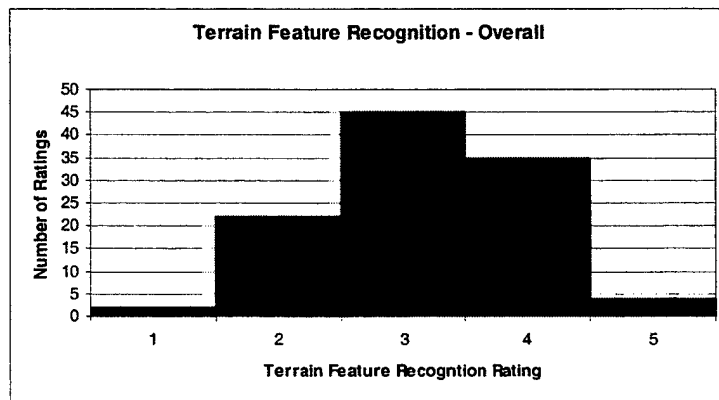

Figure 3: Overall TFR

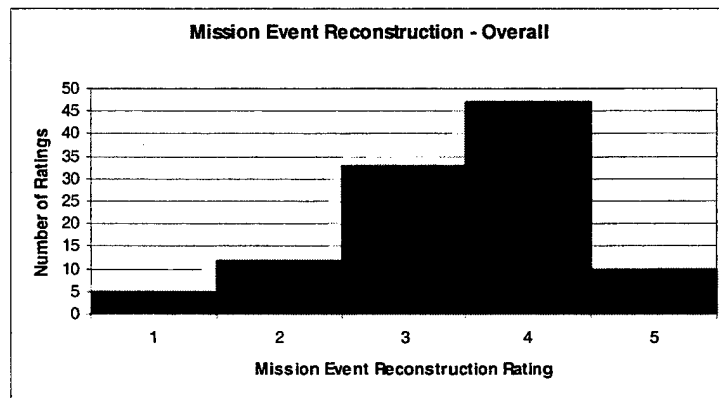

Figure 4: Overall MER

The image quality was slightly degraded by a hazy, octagonal pattern on the image. This pattern was objectionable and detracted from overall image quality. Ball Aerospace technicians stated the pattern was a result of fiber optic bundles used in the camera.

The TFR and MER given overall, as well as for each of the lighting and altitude conditions are listed in Table 4.

Table 4: General Usefulness Rating Results

	Overall	Daylight	Night	Dawn/Dusk	High Alt	Low Alt
TFR	3	4	2	3 / 4	4	3
MER	4	4	3	4	4	4

Camera Performance in Varying Lighting Conditions

For the purpose of this evaluation, daylight was defined as that period between 30 minutes after sunrise to 30 minutes before sunset. Dawn and dusk were defined as that period within 30 minutes of sunrise or sunset. Night was defined as the period from 30 minutes after sunset to 30 minutes before sunrise.

Daylight Performance

During daylight operations the camera tended to be “**Largely Useful**” for terrain feature recognition (49% of the ratings were 4 - see Figure 5).

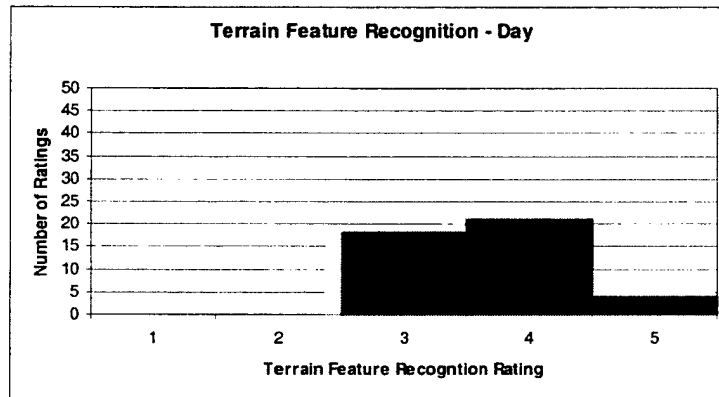

Figure 5: TFR Day

The camera image darkened significantly when the cameras were pointed within $\pm 45^\circ$ of the sun. When a portion of the sun was in the FOV, the image became completely black and terrain completely disappeared. As the sun moved further from the FOV in elevation or azimuth the image gradually returned to its original quality. When the sun was elevated above the camera beyond approximately 45° (either by aircraft roll angle or sun elevation), the sun no longer affected the video and the image was rated “**Largely Useful**” or **Completely Useful** (rating 4 or 5 respectively). The image contained excellent detail inside approximately 3 nm, with image quality approximately as good as that seen by the unaided eye. Outside 3 nm the detail in the image rapidly degraded in both the forward and side camera, and only large or high contrast features were visible (less than was visible to the unaided eye). As range increased beyond 3 nm this disparity grew, and at approximately 10 nm the unaided eye could see significantly more detail than the camera.

Video imagery during the day was also “**Largely Useful**” for mission event reconstruction (53% of the ratings were 4 – see Figure 6). The majority of the “**Marginally Useful**” ratings were received on the target board patterns. The target board was difficult to recognize (as defined by Johnson’s Criteria, Reference 3) in the video images until the slant

range decreased to approximately 1 nm. All the “**Largely Useless**” and “**Completely Useless**” ratings (2 and 1 respectively) were produced during air-to-air mission task reconstruction. Aircraft outside of 2,000 ft only appeared as bright spots and could not reliably be recognized as an aircraft until inside of 2,000 ft.

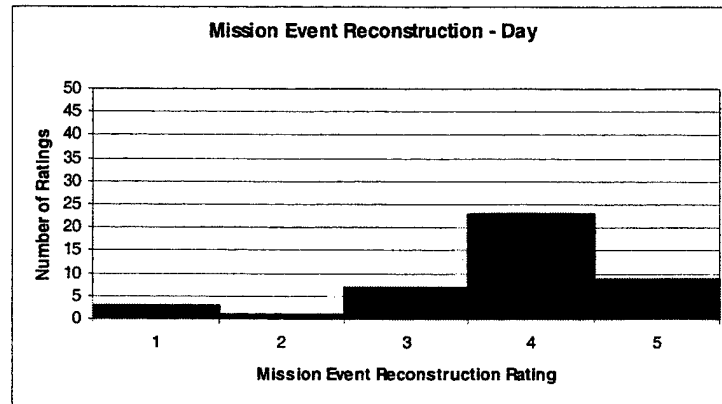

Figure 6: MER Day

During day operations the ABT had a noticeable, but not significant effect on image quality. The image appeared slightly more “washed out” (less contrast) with ABT on, and the ABT-off picture was darker than the ABT-on image, with slightly more contrast. The ABT-on image typically did not provide a better image than ABT-off with the exception of images with the sun in the camera FOV. During the air-to-air tactical maneuvering evaluation, the target aircraft was intentionally maneuvered to simultaneously place the target aircraft and the sun in the camera FOV. In this case, the ABT-on video image of the target was more defined.

Night Performance

The night video imagery was “**Largely Useless**” for terrain feature recognition (53% of the ratings were 2), but a large portion of the ratings (43%) indicated that the camera at night was “**Marginally Useful**” (rating of 3) for terrain recognition (see Figure 7).

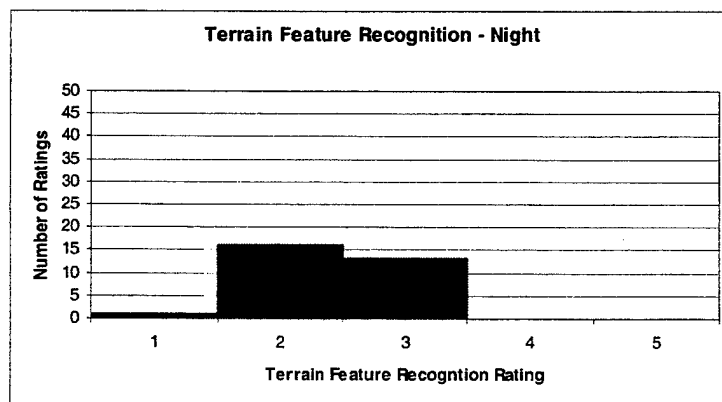

Figure 7: TFR Night

The disparity among ratings was related to the level of ambient lighting and the location of lights within the camera FOV. With higher lunar illumination the image was better, but the camera had difficulty when a bright light (man-made or natural) was in, or approached, the

camera FOV. When this occurred the image darkened and a great deal of detail was lost. This characteristic was most clearly demonstrated while flying by the Channel Islands off the California coast (sortie 8). On that sortie, the lunar illumination was 82% and island detail was clearly visible, but when a flashing light on the island entered the camera FOV the image darkened, and only large-scale features were visible. Also, during low ambient light conditions, terrain was either not visible or only silhouettes could be discerned.

Night imagery was “Marginally Useful” (59% of the ratings were 3) for mission event reconstruction (see Figure 8).

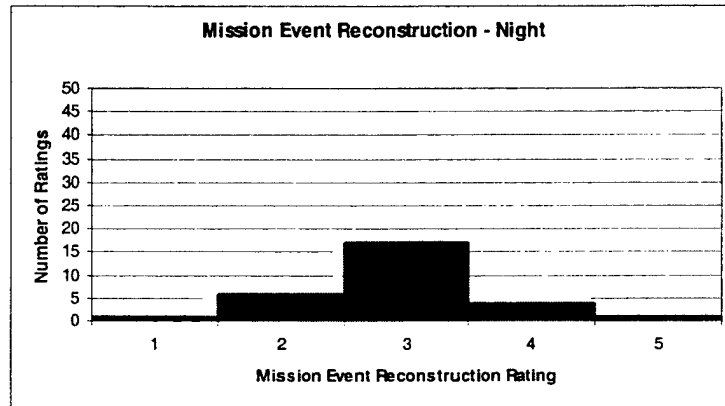

Figure 8: MER Night

The camera was an improvement over the unaided eye at night, but the image only met minimal requirements to reconstruct mission events. The camera was especially good at sensing lights at greater distances than the unaided eye, allowing for mission event reconstruction based on relative position of lights.

ABT-on at night did not improve video imagery, with one exception. ABT-on performed better than ABT-off in areas of high lighting density. Under this condition, ABT-off produced an image in which the lights were grouped together as an indistinct “blob”, but ABT-on allowed identification of separate light sources. In areas of low-density or no artificial lighting, however, point sources of light tended to be sharper with ABT off. Additionally, ABT-on video scintillated objectionably on nights with very little ambient lighting. ABT-off video exhibited no noticeable scintillation.

Dusk/Dawn Performance

The dusk and dawn performance of the camera was rated equally “Marginally Useful” and “Largely Useful” for terrain feature recognition (45% of the ratings were 3 and 45% were 4 respectively – see Figure 9).

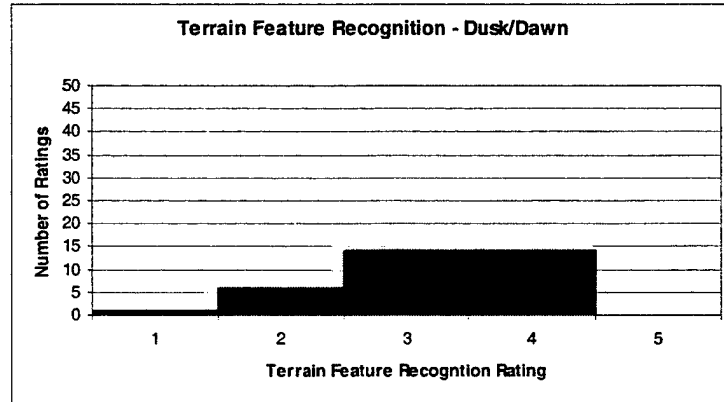

Figure 9: TFR Dusk/Dawn

The camera video imagery was “Marginally Useful” or “Largely Useful” for terrain feature recognition when the camera was aimed in an area of relatively equal lighting (resulting in the 3 and 4 ratings). The image began to degrade rapidly as terrain lighting in the same image varied. For instance, when the image contained a brightly illuminated peak but a darker or shadowed foreground, detail in the peak was largely useful. However, the shadowed area in that same image appeared as a black region in the video and provided so little detail that the ratings dropped to 2 (“Largely Useless”). A similar effect was noted when the camera was aimed at a bright horizon. One pilot noted that if the bright sky filled $\frac{1}{4}$ or less of the image (approximately), the image would return to its normal level of detail. Finally, when the sun was directly in the FOV of the camera the image turned completely black and the only object that could be seen was the aircraft’s pitot boom in the front camera and nothing in the side camera.

The camera video was “Largely Useful” at reconstructing mission events during dusk/dawn operations (57% of the ratings were 4 – see Figure 10).

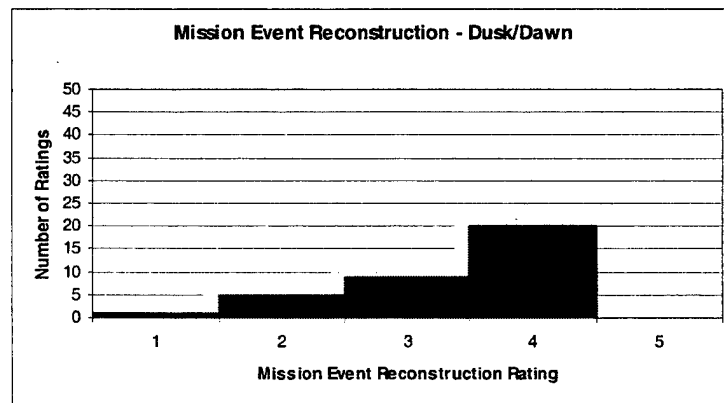

Figure 10: MER Dusk/Dawn

The image provided clear attitude information and relative altitude information throughout the dusk/dawn timeframe, except when a bright horizon or source of light was in or near (within approximately 45 degrees) the camera FOV. When the sky, brightened by the setting or rising sun, was in the camera FOV, the image darkened and significant detail was lost (resulting in ratings of 2 and 3). However, the horizon remained and general attitude information was not lost. When any portion of the sun was in the FOV of the camera, the image blackened completely and attitude information was no longer available, resulting in the rating of 1.

ABT did not improve dusk/dawn imagery. In fact, as seen previously, individual lights tended to bloom more with ABT on than with ABT off. The image also tended to have a gray fog over it when ABT was switched on. Areas of high-density lighting were not evaluated during dusk or dawn.

High and Low Altitude Performance

For purposes of this test high altitude was defined as flight above 5,000 ft AGL; all flight below 5,000 ft AGL was considered low altitude. During high altitude operations the camera was “**Largely Useful**” for terrain feature recognition (39% of the ratings were 4 – Figure 11).

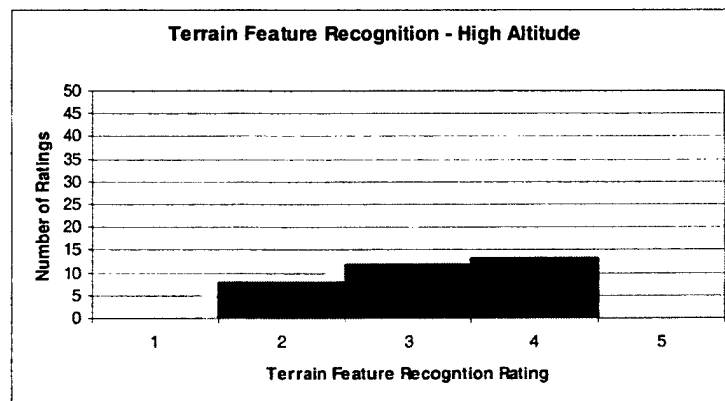

Figure 11: TFR High Altitude

The high altitude usefulness ratings were a function of lighting condition, as well as altitude. The majority of the “**Largely Useless**” ratings (87%) were given during low light conditions. A higher percentage of the “**Marginally Useful**” ratings (67%) were in daylight, and the remaining 33% were in dusk or night conditions with lunar or artificial lighting. Finally, the “**Largely Useful**” ratings were more often seen in daylight conditions, with 69% of the ratings in daylight and 31% during dusk or dawn (with the camera directed away from the sun).

At low altitude, the camera was “**Marginally Useful**” for terrain feature recognition (44% of the ratings were 3 – Figure 12).

The low altitude “**Marginally Useful**” rating was reported for a wide variety of lighting conditions. The 35% of ratings that were “**Largely Useful**” or “**Completely Useful**” were all given during daylight or dawn/dusk conditions. None of the 21% of ratings that were “**Largely Useless**” or “**Completely Useless**” were given during daylight.

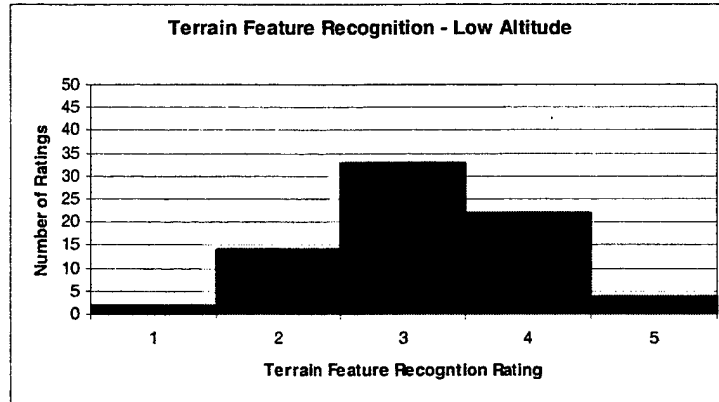

Figure 12: TFR Low Altitude

The video imagery for high altitude mission event reconstruction was **“Largely Useful”** (39% of the ratings were 4 – see Figure 13).

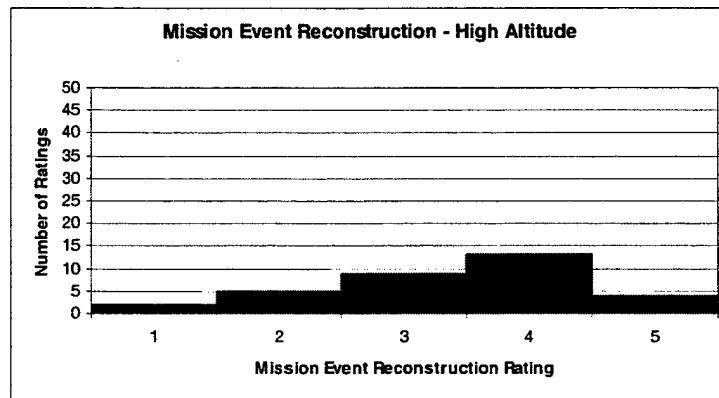

Figure 13: MER High Altitude

Similar to the TFR ratings at high altitude, the MER ratings were higher during flight conditions with increased lighting. The exception to this trend was during air-to-air tactical maneuvering, where difficulty detecting the target aircraft produced two **“Completely Useless”** ratings.

The low altitude video data were also largely useful for mission event reconstruction (46% of the ratings were 4 – see Figure 14)

There was less correlation between lighting conditions and MER ratings at low altitude, though there was a tendency toward higher ratings during daylight. The only daylight **Completely Useless** rating was during a target board pattern in which the board was difficult to recognize. The remaining daylight conditions made up 33% of **“Marginally Useful”** ratings, 58% of **“Largely Useful”** ratings, and 83% of **“Completely Useful”** ratings.

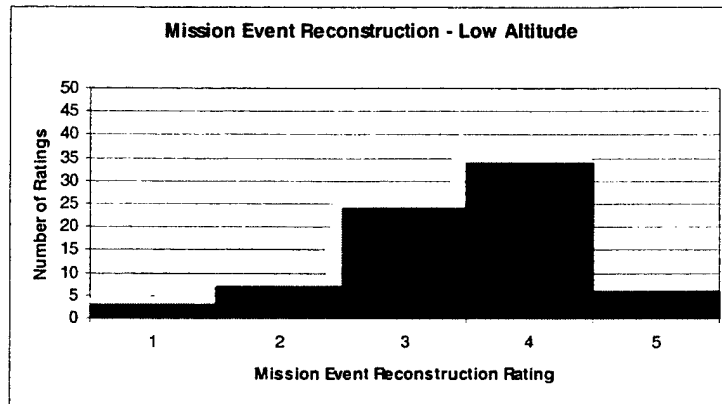

Figure 14: MER Low Altitude

Camera Performance With Target Board

During review of video recorded during daylight, the crew was able to detect the target board with the forward camera. Detection ranges varied from 1 to 2 nm. In low light conditions (dusk or dawn), the target board was visible on 75% of passes. The target board was not visible at night. The target board bar pattern was never visible through the forward camera (slant ranges were as low as 5,000 ft).

The target board was placed in the side-looking camera's FOV 6 times (4 during daylight, 2 in low light, and none at night). In all cases, the camera was able to detect the target board itself, and on two passes the bar pattern was visible. At a slant range of 1,500 ft, both horizontally and vertically oriented large bars (17 x 85 inches) were visible, but only the vertically oriented small bars (13.5 x 67.5 inches) were visible. At a slant range of 1,200 ft, all the bars were visible.

Infrared Beacon Detection

An infrared beacon was placed in the forward camera's FOV during two night missions. On both missions, the beacon was detected on the recorded video, and in both cases, the beacon appeared as a flashing point of light at very low intensity. Detection ranges for the beacon were 2 and 5 nm. For the mission with a 2 nm detection range, the battery-powered beacon had been activated approximately 3 hours prior to the test. For the mission with a 5 nm detection range, the beacon had been activated immediately prior to the test.

Conclusions

A sufficient quantity of video images was collected at each of the required conditions to meet the test objective. The evaluation of those images was completed in accordance with the objective, including the evaluation of infrared beacon visibility.

Overall, the Ball Aerospace cameras were "**Marginally Useful**" for terrain feature recognition, and "**Largely Useful**" for mission reconstruction. Whether the camera was oriented forward or to the side did not have a noticeable impact on the image quality. The aircraft altitude had some impact on the usefulness ratings, with high altitude ratings results being "flatter" (total ratings more closely distributed between 2, 3 and 4) than low altitude ratings. Within the high

and low altitude rating results, lighting conditions had a noticeable effect on the usefulness rating distribution, with higher ratings occurring during increased lighting.

When only lighting conditions were considered, the camera operated well when lighting intensity was relatively evenly distributed across the screen, but when points or areas of the image were brighter, the camera image darkened so only the bright areas were visible. In the extreme case of the sun or a bright point source of light at night being in the camera FOV, the entire image except for the light source would be lost, with one exception; objects close to the camera such as the pitot boom, or the target aircraft during air-to-air maneuvering (1,000 to 1,500 feet in front of the camera) were seen even with the sun in the FOV.

The Anti-Blooming Technology did not noticeably improve the overall image with the exception of areas of high-density lighting or when a target and the sun were in the camera FOV. During day operations the ABT-on seemed to put a gray fog over the image, brightening the overall picture at the expense of detail. The ABT-off image appeared darker overall, but typically more detail could be seen in the image. However, ABT-on images were better when a close-in (1,000 to 1,500 ft) target aircraft and the sun were in the camera FOV. In this case, more detail was visible on the target aircraft. At night with ABT on, the image was typically worse, except when the camera was viewing a lighted city. In this specific case, individual light sources could be seen, which otherwise would have appeared as a large continuous "blob". When single, or low light density scenes were in the FOV, ABT-on produced an objectionable glow around the entire image, whereas the ABT-off imagery did not have the glow around it, and individual lights appeared crisper. On night sorties with very low ambient lighting and ABT on there was objectionable scintillation, which completely disappeared with ABT off. The ABT did not, in any of the cases reviewed, have a positive impact on the imagery with the exceptions of close in targets in the vicinity of the sun or at night when viewing areas of high-density lighting.

THIS PAGE INTENTIONALLY LEFT BLANK

CONCLUSIONS

The primary objective of the PEEPING TALON test program, to record data from a GAINR, Ashtech GPS receiver and forward/side-looking cameras, was met. Sufficient usable data were recorded on eight of the twelve missions flown during the test.

The primary test objective was met despite deficiencies in the navigation systems, which produced unusable data on several of the sorties. The unusable data from the sorties listed in Table 2 were either due to circumstances where the system was capable of meeting the requirements but was not allowed to collect the data (sortie 6a), due to a navigation system malfunction (sorties 6b and 9) or human error (sortie 10). The reasons for these navigation system malfunctions could not be determined due to insufficient data to narrow the cause to any particular component.

A sufficient number of video images were recorded to meet test objectives and allow an evaluation of camera capability in all desired flight conditions. Overall, the Ball Aerospace cameras were "**Marginally Useful**" for terrain feature recognition, and "**Largely Useful**" for mission reconstruction. The camera performance received higher ratings and more favorable comments as ambient lighting increased. The camera video degraded when bright light sources, both natural and man-made, were near the camera FOV (within approximately 45°). In these instances, the image would darken and detail was lost. When the point source of bright light was within the camera FOV, the entire image except for the light source would be lost. The exception was when a close-range airborne target and the sun were both in the camera FOV simultaneously. The camera's Anti-Blooming Technology did not noticeably improve the overall image with the exception of areas of high-density lighting or when a target and the sun were in the camera FOV. The camera was able to detect a ground-based infrared beacon, presenting it on the recorded image as a faint point light source.

REFERENCES

Reference 1: Giebner, Michael G, Captain, USAF, Air Force Institute of Technology Master's Thesis, published Mar 03

Reference 2: Air Force Flight Test Center Test Plan Preparation Guide

Reference 3: Install Camera System for PEEPING TALON TMP, AFFTC Modification #M02A325A

Reference 4: Johnson, John, USA, Analysis of Image Forming Systems, U. S. Army Engineering Research and Development Labs, Fort Belvoir, Virginia, October 1958.

APPENDIX 1: CAMERA PREFLIGHT SUMMARY

Camera Pre-flight Summary

Flight # / Time / Date	Front Lens	Front Aperture	Side Lens	Side Aperture
#0 / 0930 / 7 Oct 02	N/A	N/A	50 mm	16
#1 / 0900 / 8 Oct 02	N/A	N/A	50 mm	16
#2 / 1410 / 9 Oct 02	25 mm	16	35 mm	16
#3 / 1030 / 10 Oct 02	35 mm	16	25 mm	16
#4 / 0900 / 11 Oct 02	35 mm	16	50 mm	16
#5 / 0650 / 16 Oct 02	35 mm	4	50 mm	4
#6a / 1800 / 16 Oct 02	35 mm	1.4	50 mm	1.4
#6b / 1800 / 21 Oct 02	35 mm	4	50 mm	4
#7 / 1230 / 22 Oct 02	35 mm	16	50 mm	16
#8 / 1930 / 22 Oct 02	35 mm	1.4	50 mm	1.4
#9 / 0600 / 29 Oct 02	50 mm ¹	16	50 mm	16
#10 / 1900 / 29 Oct 02	35 mm	1.4	50 mm	1.4
#11 / 1900 / 30 Oct 02	35 mm	1.4	50 mm	1.4

50 mm = narrow FOV = 15.3° FOV
 35 mm = medium FOV = 22.4° FOV
 25 mm = wide FOV = 32.0° FOV

¹ Front camera was set at 10°57" look-down angle from aircraft horizontal reference plane. All others were set at the minimum look-down angle of 5°59")

APPENDIX 2: TEST MATRIX

APPENDIX 3: POST-FLIGHT VIDEO UTILITY RATING SCALE

Post-Flight Video Utility Rating Scale

Date		Time (L)	
Crew		Camera	
Test Point/ Maneuver			
Location			
Altitude		Airspeed	
Mag Heading		Clouds/Haze	
Sun / Moon:			
Elevation		Azimuth	
Moon Phase		Illumination	
Other Lighting / Illumination Sources			

Task: Terrain Feature Recognition:

1	2	3	4	5
---	---	---	---	---

Comments:

Task: Mission Event Reconstruction:

1	2	3	4	5
---	---	---	---	---

Comments:

Post-Flight Rating Scale Definitions

Rating	Criteria	Definition
1	Completely Useless	Task cannot be performed. Task not accomplished due to image deficiencies.
2	Largely Useless	Major problems encountered. Task accomplished with great difficulty or accomplished poorly. Significant degradation of task due to image quality.
3	Marginally Useful	The task can be accomplished with some difficulty. Image meets minimal requirements to accomplish task.
4	Largely Useful	The task can be completed as intended. Image improvements would make task easier or more efficient.
5	Completely Useful	Task accomplished satisfactorily. No image improvement required.

APPENDIX 4: LIST OF ABBREVIATIONS, ACRONYMS AND SYMBOLS

List of Abbreviations, Acronyms and Symbols

Abbreviation	Definition
ABT	Anti-Bloom Technology
AFB	Air Force Base
AFFTC	Air Force Flight Test Center
AFFTCI	Air Force Flight Test Center Instruction
AFIT	Air Force Institute of Technology
AFRL	Air Force Research Lab
AGL	Above ground level
az	Azimuth
CATEX	Categorical Exclusion
CCD	Charge coupled device
CCP	Cockpit Control Panel
CDI	Course Deviation Indicator
DME	Distance measuring equipment
EAGC	Electronic Automatic Gain Control
EDW	Edwards AFB TACAN identifier
EGI	Embedded GPS/INS
el	Elevation
FIM	Filmore TACAN identifier
FOV	Field of view
FTE	Flight test engineer
FTN	Flight test navigator
GAINR	GPS-Aided Inertial Navigation Reference
GICCD	Gated Intensified Charge Coupled Device
GPS	Global positioning system
HUD	Head up display
IFR	Instrument Flight Rules
IFSSR	Intelligent Flash-memory Solid State Recorder
IITV	Image intensified television
ILS	Instrument Landing System
IMU	Inertial Measurement Unit
IP	Initial Point
IR	Infrared
JON	Job Order Number
JPEG	Joint Photographic Experts Group
KIAS	Knots indicated airspeed

LA	Los Angeles
LCD	Liquid crystal display
MIL	Military
MS	Margin of Safety
MSL	Mean sea level
NAS	Naval Air Station
nm	Nautical Mile
NTD	Point Mugu NAS TACAN identifier
PAR	Program Assessment Review
PDT	Pacific Daylight Savings Time
PFP	Pre-Flight Panel
PMD	Palmdale TACAN identifier
PST	Pacific Standard Time
RTB	Return to Base
SP	Slow play
SPORT	Space positioning optical radar tracking
TACAN	Tactical air navigation
TBD	To be determined
TPS	Test Pilot School
UHF	Ultrahigh frequency
USAF	United States Air Force
VMC	Visual meteorological conditions
VSI	Vision Systems International

Distribution List

Defense Technical Information Center 8725 John J. Kingman Rd, Suite 0944 Attn: Joyce Chiras DTIC-OCA Fort Belvoir, VA 22060-6218	2
AUL/LSE Bldg 1405, 600 Chennault Circle Maxwell AFB, AL 36112-6424	1
FASTC/TAA 4115 Hebble Creek Rd, Suite 23 Wright-Patterson AFB, OH 45433-5627	1
AFFTC/HO 305 E. Popson Ave, Bldg 1405 Edwards AFB, CA 93524-6595	1
412 TW/ENTL 307 E. Popson Ave, Bldg 1400, Rm 110 Edwards AFB, CA 93524-6630	3
Capt Mike Giebner USAF Test Pilot School 220 S. Wolfe Ave Edwards AFB, CA 93524-6485	1
Capt Ron Schwing 509 First Light St Henderson, NV 89052	1
Maj Bill Peris 6910 Balchen Dr Edwards AFB, CA 93523	1
Ball Aerospace Attn: Steve Shimer / Brian Gillespie Component Technologies Boulder, Colorado 90201	1
Vision Systems International Attn: Fred Mulholland 641 River Oaks Pkwy San Jose, CA 95134	1

Randall Brown
2255 H Street
Wright-Patterson AFB, OH 45433-7022

1

James Barnaba
ASC/ENFC
2530 Loop Road West
B560
Wright-Patterson AFB, OH 45433-7101

1

Air Force Research Lab
Attn: 1Lt Virgil Zetterland
AFRL/MNGI
Bldg A10
Eglin AFB, FL 32542-6810

1

Steve Brown
412th Test Wing/ENVA
195 E. Popson
Bldg 1609
Edwards AFB, CA 93524

1