



**US Army Corps  
of Engineers®**  
Engineer Research and  
Development Center

20030325 058

## **Periodic Inspections of Kahului and Laupahoehoe Breakwaters, Hawaii**

**Armor Unit Monitoring for Period 1992/93-2001**

Robert R. Bottin, Jr., and Daniel T. Meyers

August 2002

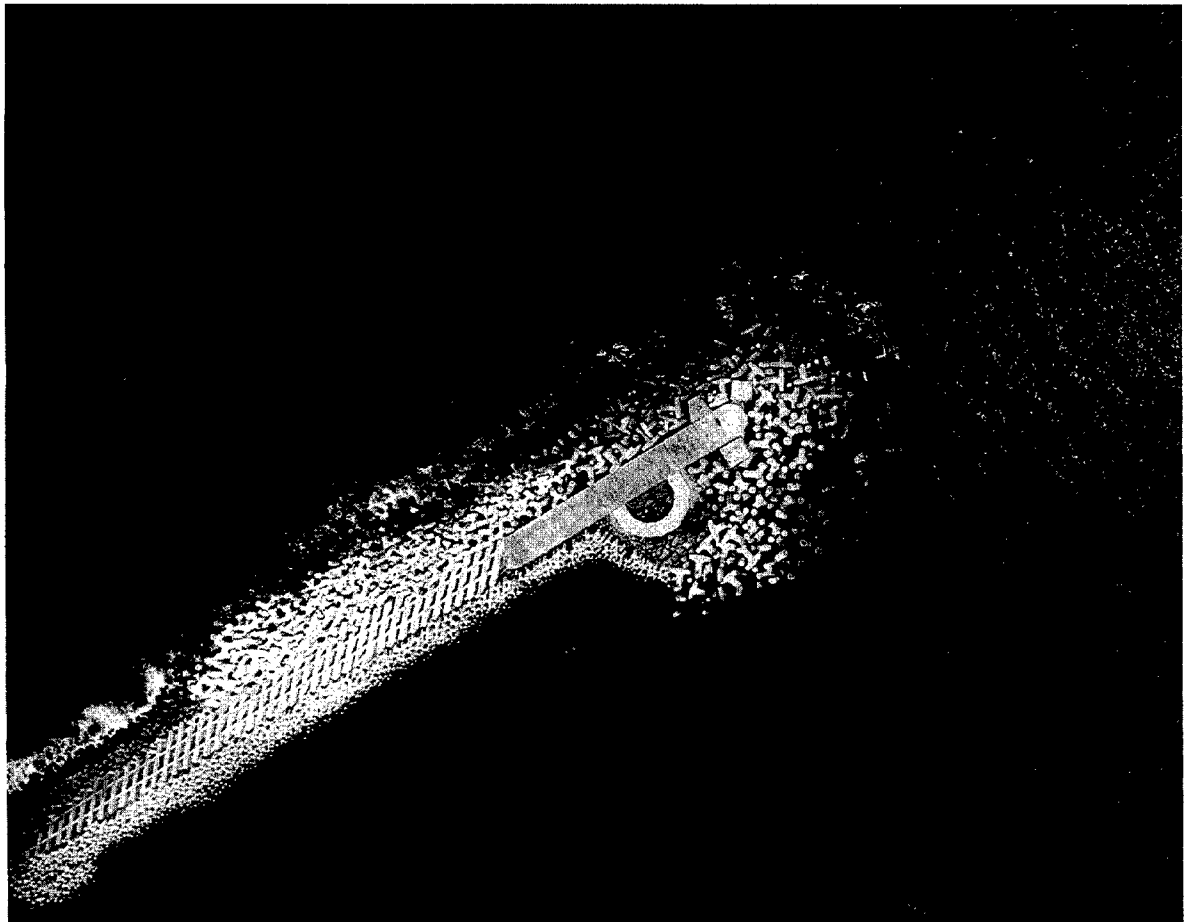

ERDC/CHL TR-02-11

Coastal and Hydraulics Laboratory

The contents of this report are not to be used for advertising, publication, or promotional purposes. Citation of trade names does not constitute an official endorsement or approval of the use of such commercial products.

The findings of this report are not to be construed as an official Department of the Army position, unless so designated by other authorized documents.



PRINTED ON RECYCLED PAPER

# **Periodic Inspections of Kahului and Laupahoehoe Breakwaters, Hawaii**

## **Armor Unit Monitoring for Period 1992/93-2001**

by Robert R. Bottin, Jr.  
U.S. Army Engineer Research and Development Center  
3909 Halls Ferry Road  
Vicksburg, MS 39180-6199

Daniel T. Meyers  
U.S. Army Engineer District, Honolulu  
Building 230  
Fort Shafter, HI 96858-5440

Final report

Approved for public release; distribution is unlimited

# Contents

---

Preface .....	vi
Conversion Factors, Non-SI to SI Units of Measurement.....	vii
1—Introduction .....	1
Monitoring Completed Navigation Projects Program .....	1
Work Unit Objective and Monitoring Approach .....	2
Project Locations and Brief Histories .....	3
Kahului Harbor.....	3
Laupahoehoe Point boat-launching facility.....	10
Prior Monitoring (Periodic Inspections) of Sites .....	13
Purpose of Current Monitoring.....	13
2—Monitoring Plan and Data Comparison.....	14
Targeting and Ground Surveys .....	14
Aerial Photography.....	19
Photogrammetric Analysis of Armor Unit Targets.....	19
Broken Armor Unit Surveys.....	31
3—Summary and Findings.....	38
References .....	40
Tables 1-11	
SF 298	

## List of Figures

---

Figure 1. Project locations for Kahului and Laupahoehoe.....	4
Figure 2. Layout of Kahului Harbor, Maui, HI.....	5
Figure 3. Aerial view of Kahului Harbor (2001).....	6

Figure 4.	Typical cross section of 1931 Kahului breakwater trunk construction.....	7
Figure 5.	Typical cross section for 1956 Kahului breakwater repairs.....	7
Figure 6.	1996 Kahului breakwater repairs.....	8
Figure 7.	Kahului west breakwater repairs of 1973 .....	9
Figure 8.	Layout of Laupahoehoe boat-launching facility.....	11
Figure 9.	Cross section of Laupahoehoe breakwater .....	12
Figure 10.	Aerial photograph of Laupahoehoe boat-launching facility (2001) .....	12
Figure 11.	Monuments used to establish survey control at Kahului Harbor ....	15
Figure 12.	Monuments used to establish survey control at Laupahoehoe boat-launching facility .....	15
Figure 13.	Locations of targeted armor units on Kahului east breakwater .....	16
Figure 14.	Locations of targeted armor units on Kahului west breakwater ....	17
Figure 15.	Locations of targeted armor units on Laupahoehoe breakwater .....	18
Figure 16.	Example of targeted tribar .....	19
Figure 17.	Stereo pair photographs of outer portion of Kahului east breakwater.....	20
Figure 18.	Stereo pair photographs of inner portion of Kahului east breakwater.....	21
Figure 19.	Stereo pair photographs of outer portion of Kahului west breakwater.....	22
Figure 20.	Stereo pair photographs of inner portion of Kahului west breakwater.....	23
Figure 21.	Stereo pair photographs of Laupahoehoe breakwaters .....	24
Figure 22.	Comparison of representative targeted armor unit positions relative to x, y, and z axes.....	27
Figure 23.	Photo map of head of Kahului east breakwater .....	29
Figure 24.	Photo map of head of Kahului west breakwater .....	30

Figure 25. Photo map of Laupahoehoe breakwater.....31

Figure 26. Approximate locations of broken/cracked armor units along  
outer portion of Kahului east breakwater..... 33

Figure 27. Approximate locations of broken/cracked armor units along out  
portion of Kahului west breakwater.....34

Figure 28. Dolos with mid-shank crack .....35

Figure 29. Dolos with fluke-shank break .....35

Figure 30. Dolos with shank-fluke break .....36

Figure 31. Tribar with break through center section of unit .....36

# Preface

---

The study reported herein was conducted as part of the Monitoring Completed Navigation Projects (MCNP) Program, formerly Monitoring Completed Coastal Projects Program. Work was conducted under Work Unit IM-7, "Periodic Inspections." Overall program management for MCNP is administered by Headquarters, U.S. Army Corps of Engineers (HQUSACE). The Coastal and Hydraulics Laboratory (CHL), U.S. Army Engineer Research and Development Center (ERDC), is responsible for technical as well as data management and support for HQUSACE review and technology transfer. Technical Monitors for the MCNP program are Messrs. Barry W. Holliday, Charles B. Chesnutt, and David B. Wingerd (HQUSACE). The Program Manager is Mr. Robert R. Bottin, Jr., (CHL).

This report is part of a series which tracks the long-term structural response of the Kahului and Laupahoehoe breakwaters, HI, to their environment. Limited ground surveys, aerial photography, and photogrammetric analysis of the breakwater were conducted by Richard B. Davis, Inc., Smith River, CA, and David C. Smith & Associates, Inc., Portland, OR, under contract to the Corps of Engineers. A broken armor unit survey was conducted by Messrs. Bottin, Hugh F. Acuff, Larry R. Tolliver, Glenn B. Myrick, Ms. Kristi Evans (CHL), and Mr. Daniel T. Meyers, U.S. Army Engineer District, Honolulu (CEPOH).

The work was conducted during the period August through October 2001 under the general supervision of Mr. Thomas W. Richardson, Director, CHL, and Mr. Thomas J. Pokrefke, Jr., former Acting Assistant Director, CHL, and under direct supervision of Mr. Dennis G. Markle, Chief, Coastal Harbors and Structures Branch. This report was prepared by Messrs. Bottin, CHL, and Meyers, CEPOH.

At the time of publication of this report Dr. James R. Houston was Director of ERDC, and COL John W. Morris III, EN, was Commander and Executive Director.

*The contents of this report are not to be used for advertising, publication, or promotional purposes. Citation of trade names does not constitute an official endorsement or approval of the use of such commercial products.*

# Conversion Factors, Non-SI to SI Units of Measurement

---

Non-SI units of measurement used in figures, plates, and tables of this report can be converted to SI units as follows:

Multiply	By	To Obtain
acres	4,046.873	square meters
cubic yards	0.7645549	cubic meters
degrees (angle)	0.01745329	radians
feet	30.48	centimeters
feet	0.3048	meters
inches	2.54	centimeters
miles (U.S. statute)	1.609347	kilometers
pounds (mass)	0.4535924	kilograms
tons (2,000 pounds, mass)	907.1847	kilograms

# 1 Introduction

---

## Monitoring Completed Navigation Projects Program

The goal of the Monitoring Completed Navigation Projects (MCNP) Program (formerly the Monitoring Completed Coastal Projects Program) is the advancement of coastal and hydraulic engineering technology. The program is designed to determine how well projects are accomplishing their purposes and are resisting the attacks by their physical environment. These determinations, combined with concepts and understanding already available, will lead to creating more accurate and economical engineering solutions to coastal and hydraulic problems; to strengthening and improving design criteria and methodology; to improving construction practices and cost-effectiveness; and to improving operations and maintenance techniques.

To develop direction for the program, the U.S. Army Corps of Engineers initially established an ad hoc committee of engineers and scientists. The committee formulated the objectives of the program, developed its operation philosophy, recommended funding levels, and established criteria and procedures for project selection. A significant result of their efforts was a prioritized listing of problem areas to be addressed, essentially a listing of the areas of interest of the program.

Corps offices are invited to nominate projects for inclusion in the monitoring program as funds become available. The MCNP Program is governed by Engineer Regulation 1110-2-8151 (Headquarters, U.S. Army Corps of Engineers (HQUSACE) 1997). A selection committee reviews and prioritizes the projects nominated based on criteria established in the regulation. The prioritized list is reviewed by the Program Monitors at HQUSACE. Final selection is based on this prioritized list, national priorities, and the availability of funding.

The overall monitoring program is under the management of the Coastal and Hydraulics Laboratory (CHL), U.S. Army Engineer Research and Development Center (ERDC), with guidance from HQUSACE. Development of monitoring plans and the conduct of data collection and analyses are dependent upon the combined resources of CHL and the District/Division. The inspection for the study reported herein, was completed as part of the "Periodic Inspections" Work Unit of the MCNP program.

## Work Unit Objective and Monitoring Approach

The objective of the "Periodic Inspections" Work Unit in the MCNP Program is to periodically monitor selected coastal navigation structures to gain an understanding of the long-term structural response of unique structures to their environment. These periodic data sets are used to improve knowledge in design, construction, and maintenance of both existing and proposed coastal navigation projects. These data also will help avoid repeating past design mistakes that have resulted in structure failure and/or high maintenance costs. Past projects monitored under the MCNP Program and/or structures with unique design features that may have application at other sites are considered for inclusion in the periodic inspections monitoring program. Selected sites are presented as candidates for development of a periodic monitoring plan. Once the monitoring plan for a site is approved and funds are provided, monitoring of the site is initiated. Normally, base conditions are established and documented in the initial effort. The site then is reinspected periodically (frequency of surveys is based on a balance of need and funding for each monitoring site) to obtain long-term structural performance data.

Relatively low-cost remote sensing tools and techniques, with limited ground truthing surveys, are the primary inspection tools used in the monitoring efforts. Most periodic inspections consist of capturing above-water conditions of the structure at periodic intervals using high-resolution aerial photography. Periodic aerial photographs are compared visually to gauge the degree of in-depth analysis required to quantify structural changes (primarily armor unit movement). Data analysis involves using photogrammetric techniques developed for and successfully applied at other coastal sites. At sites where local wave data are being gathered by other projects and/or agencies, and these data can be acquired at a relatively low cost, wave data are correlated with structural changes. In areas where these data are not available, general observations and/or documentation of major storms occurring in the locality are presented along with the monitoring data. Ground surveys are limited to the level needed to establish accuracy of the photogrammetric techniques.

When a coastal structure is photographed at low tide, an accurate permanent record of all visible armor units is obtained. Through the use of stereoscopic, photogrammetric instruments in conjunction with photographs, details of structure geometry can be defined at a point in time. By direct comparison of photographs taken at different times, as well as the photogrammetric data resolved from each set of photographs, geometric changes (i.e., armor unit movement and/or breakage) of the structure can be defined as a function of time. Thus, periodic inspections of the structures will capture permanent data that can be compared and analyzed to determine if structure changes are occurring that indicate possible failure modes and the need to monitor the structure(s) more closely. The Kahului and Laupahoehoe breakwaters, HI, were nominated for periodic monitoring by the U.S. Army Engineer District, Honolulu. Initial monitoring of base level conditions was completed in 1992 at Laupahoehoe and 1993 at Kahului (Markle and Boc 1994).

Two additional Honolulu District projects have been monitored previously under the "Periodic Inspections" Work Unit. Base conditions have been defined for the Nawiliwili Harbor breakwater, Kauai, HI (Bottin and Boc 1996), and the Ofu Harbor breakwater, American Samoa (Bottin and Boc 1997).

## Project Locations and Brief Histories

### Kahului Harbor

Kahului Harbor is the only deep-draft harbor on the island of Maui. Maui is the second largest of the Hawaiian Islands. The harbor is located on Maui's north shore approximately 150 km (95 miles)<sup>1</sup> southeast of Honolulu, Oahu, HI (Figure 1). The harbor is exposed to winds and waves from the north and northeast. Both northeast tradewind waves and northern swell, impact on Kahului Harbor. The trade winds predominate the summer season, producing 6- to 10-sec, 1.2- to 3.7-m (4- to 12-ft) deepwater waves. Intense winter storms in the north Pacific Ocean create northern swell during the months of October through March. Deepwater waves can attain heights of 7.6 m (25 ft) with wave periods from 12 to 18 sec. These storms, as well as hurricanes, are sources of the largest waves that reach the Hawaiian Islands.

Kahului Harbor is rich in construction, repair, and rehabilitation history as noted in U.S. Army Engineer District, Honolulu (1981) and Sargent, Markle, and Grace (1988). The harbor complex was initiated when a berthing area, a dredged entrance channel, and a 122-m-long (400-ft-long) armor stone east breakwater were constructed by the Kahului Railroad Company in 1900. The Corps of Engineer's first involvement with the project began in 1913 when the east breakwater was extended 122 m (400 ft). The west breakwater was constructed to a length of 594 m (1,950 ft) in 1919. In 1931, the east and west breakwaters were extended to their current lengths of 843 and 706 m (2,766 and 2,315 ft), respectively. A layout of the harbor is shown in Figure 2 and an aerial view is shown in Figure 3.

All construction through 1931 utilized a single layer of keyed and fitted, 7,257-kg (8-ton) armor stone placed between the +4.0-m (+13-ft)<sup>2</sup> crest and an elevation (el) of -4.6 m (-15 ft). Side slopes above the -4.6-m (-15-ft) el were 1V:2H on the heads and 1V:1.5H on the trunks (Figure 4). Below the -4.6-m (-15-ft) el, the 1V:1H sloped structure was constructed of quarry-run stone (11.3-kg (25-lb) minimum stone weight).

---

<sup>1</sup> Units of measurement in the text of this report are shown in SI units, followed by non-SI units in parenthesis. In addition, a table of factors for converting non-SI units of measurement used in figures, plates, and tables in this report to SI units is presented on page vii.

<sup>2</sup> All elevations (el) and depths cited herein are in meters (feet) referred to mean lower low water (mllw).

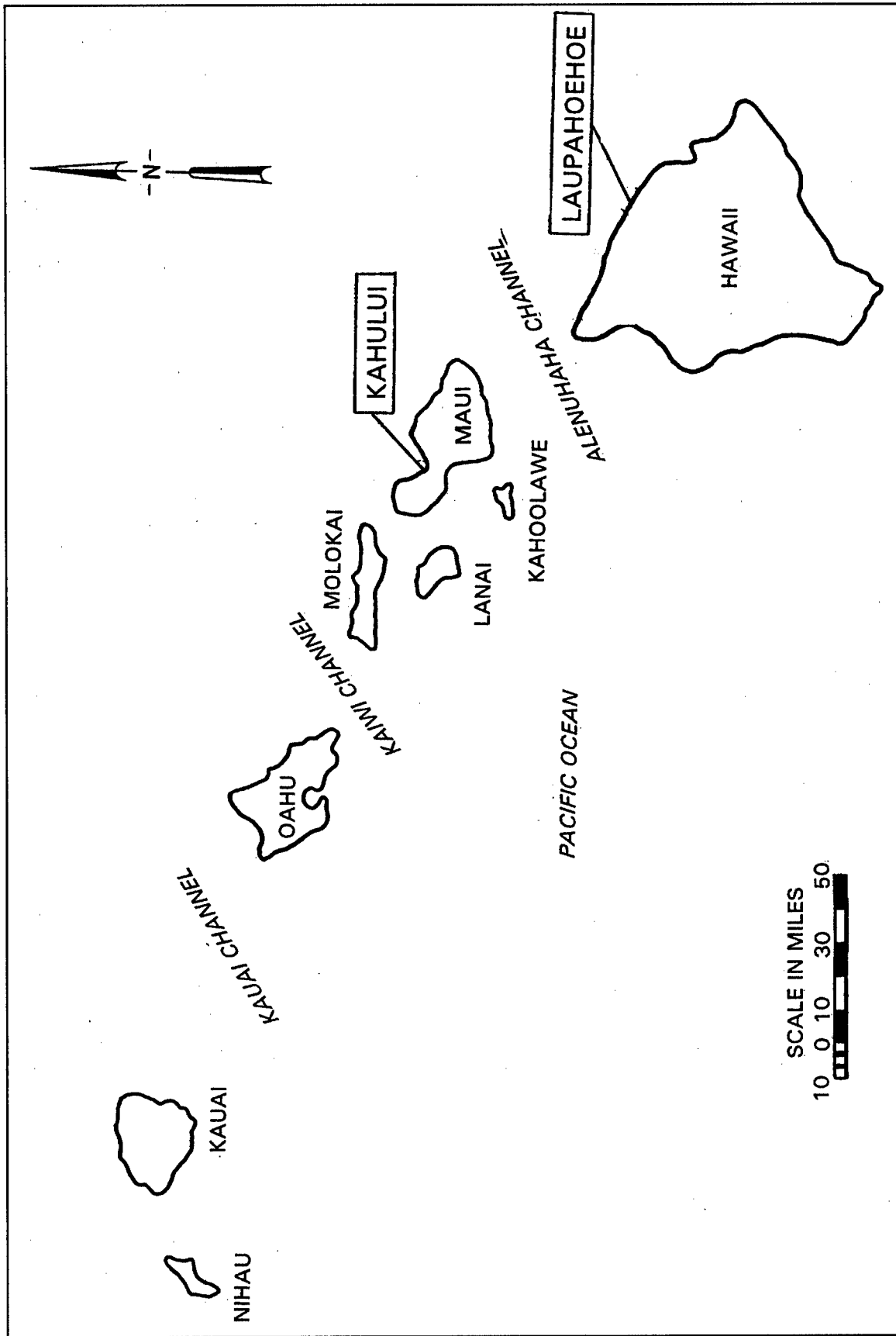

Figure 1. Project locations for Kahului and Laupahoehoe

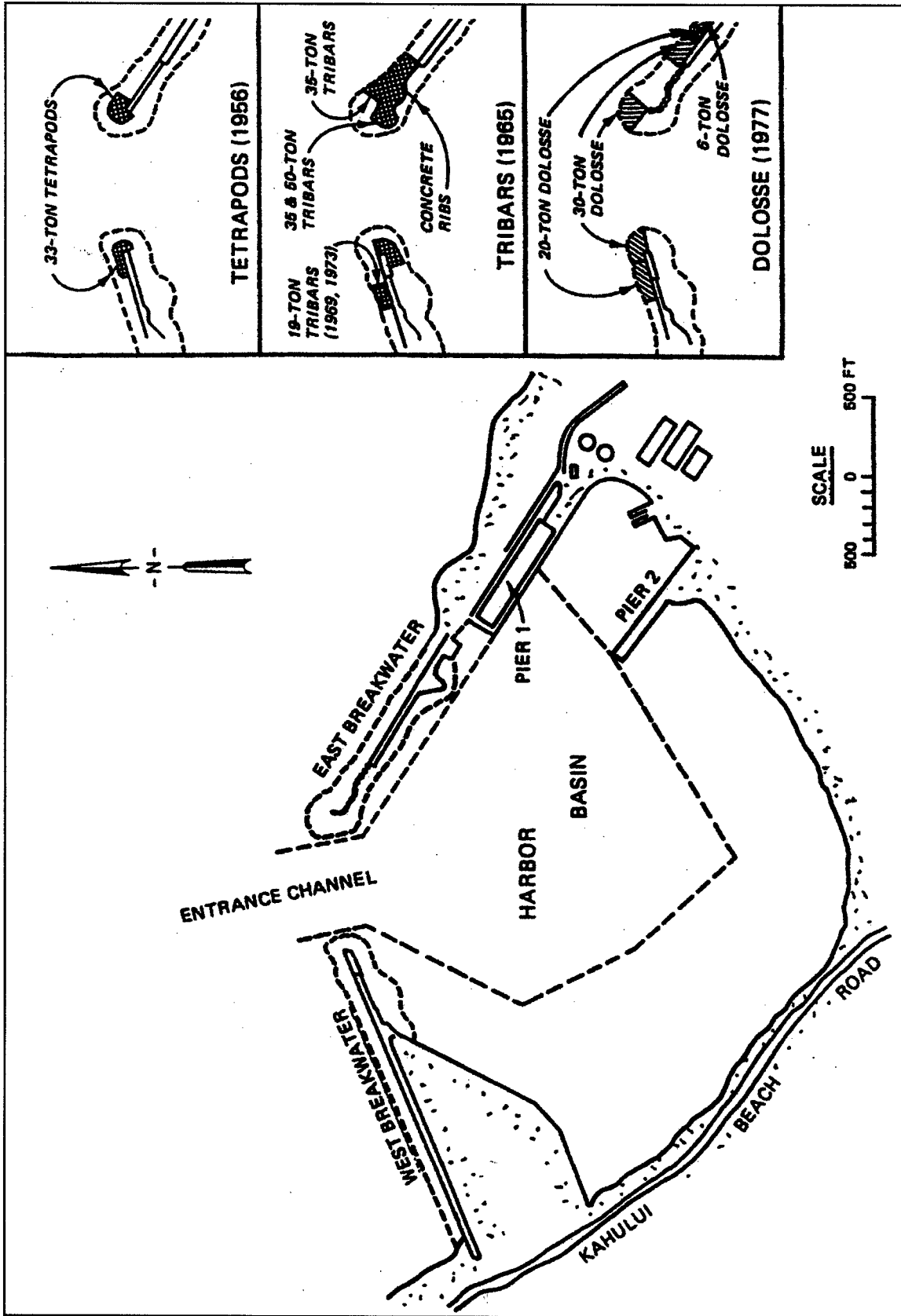

Figure 2. Layout of Kahului Harbor, Maui, HI

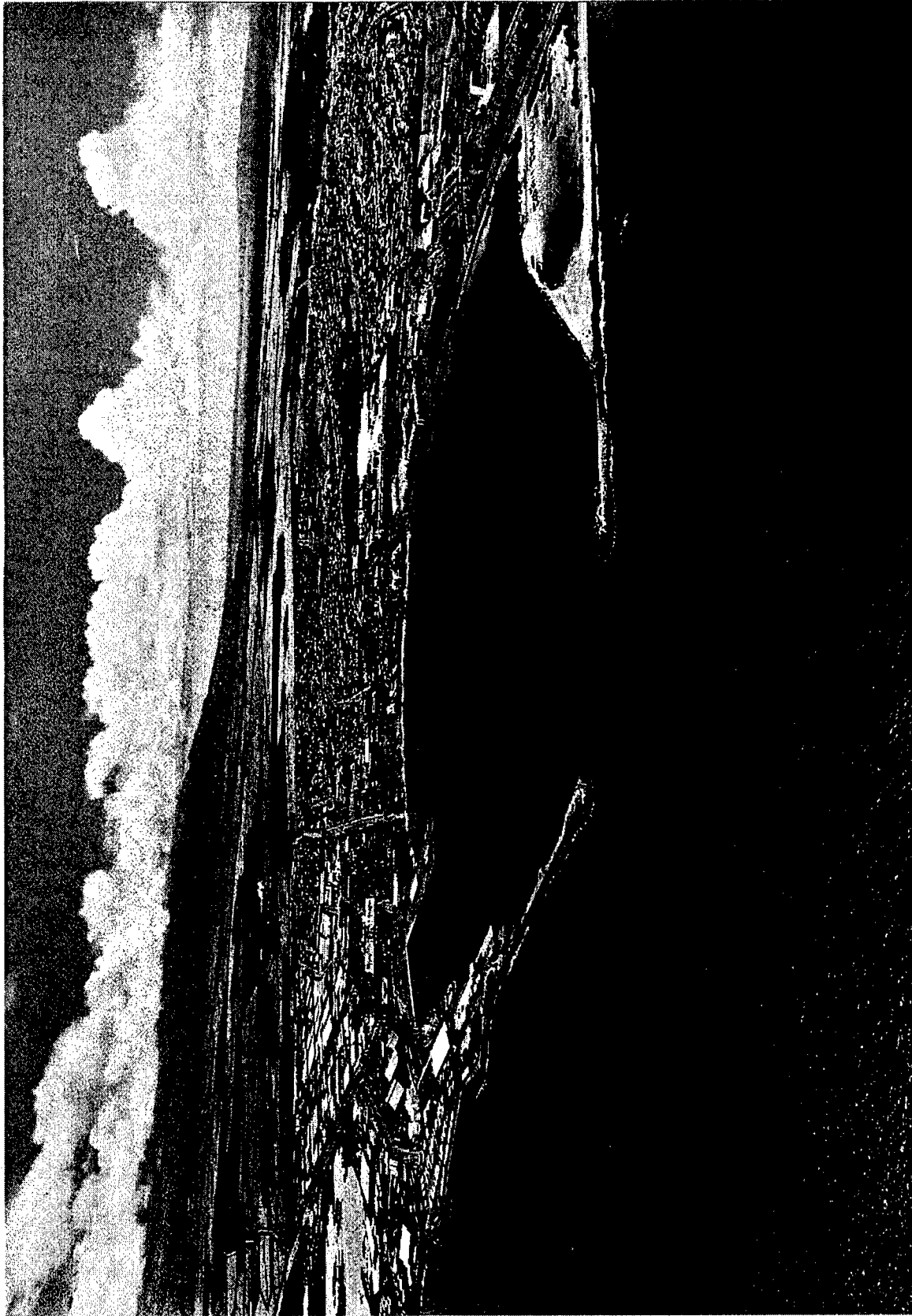

Figure 3. Aerial view of Kahului Harbor (2001)

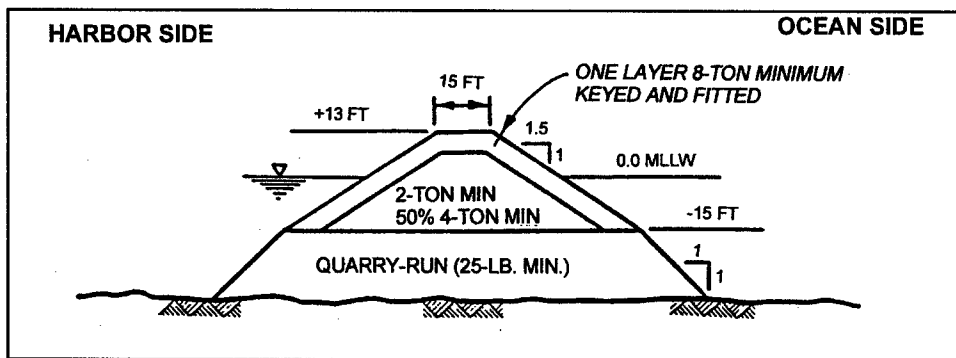

Figure 4. Typical cross section of 1931 Kahului breakwater trunk construction

Between 1931 and 1954, both breakwaters were severely damaged on numerous occasions and each repair, or rehabilitation, was completed by restoring the structure to its original condition with 7,257-kg (8-ton) keyed and fitted armor stone. In March of 1954, storm waves, with estimated 10.4-m (34-ft) breaker heights at the structure heads, attacked Kahului Harbor for a 3-day period. The outer 56.4 and 91.4 m (185 and 300 ft) of the east and west breakwaters, respectively, were severely damaged. This extensive damage initiated actions to base needed repairs on current design criteria rather than restoring the structure to its prestorm conditions. In 1956, repairs were completed on both breakwaters using 29,940-kg (33-ton) unreinforced tetrapods and a concrete cap (Figure 5). The new armor units were placed on the heads of both breakwaters and extended 76.2 m (250 ft) shoreward along the sea-side face on the west breakwater trunk.

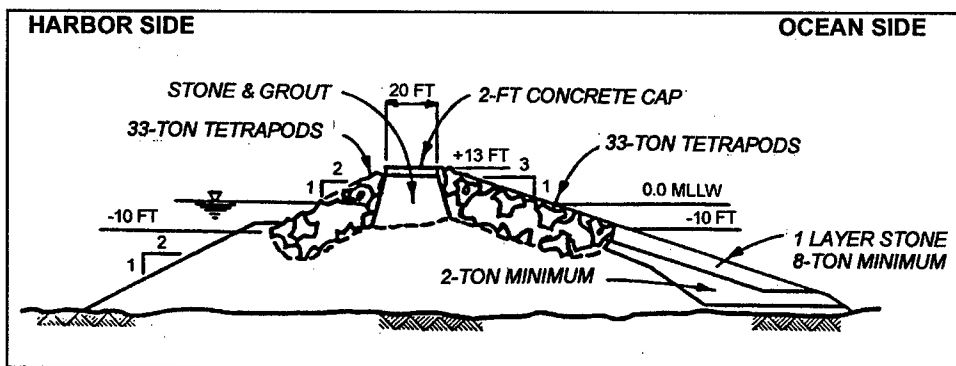

Figure 5. Typical cross section for 1956 Kahului breakwater repairs

A storm in 1958 with estimated wave heights of 7.6 m (25 ft) at the structures caused extensive damage to both breakwaters. A breach in excess of 45.7 m (150 ft) was opened up on the east breakwater at the transition between the armor stone and tetrapods. On the west breakwater, all of the tetrapods on the harbor-side quarter of the head were swept away. The 1V:2H slope used in this area was felt to be the major design deficiency. Temporary repairs of the east breakwater, consisting of a large monolithic concrete cap and placement of 10,885-kg (12-ton) or larger armor stone on the sea-side face, were completed in 1959.

A major breakwater rehabilitation was completed in 1966. Both heads, and 108.2 m (355 ft) of sea-side slope of the structure immediately shoreward of the east head were included in the repair (Figure 6). The design was model-studied at ERDC (Jackson 1964). The inboard quarters of both heads were armored with two layers of 45,360-kg (50-ton) tribars on the upper one-third of the slope, while the lower two-thirds was protected by a double layer of 31,750-kg (35-ton) tribars. A two-layer system of 31,750-kg (35-ton) tribars was placed from the new concrete rib cap to the toe of the rehabilitated sea-side slope of the east breakwater trunk.

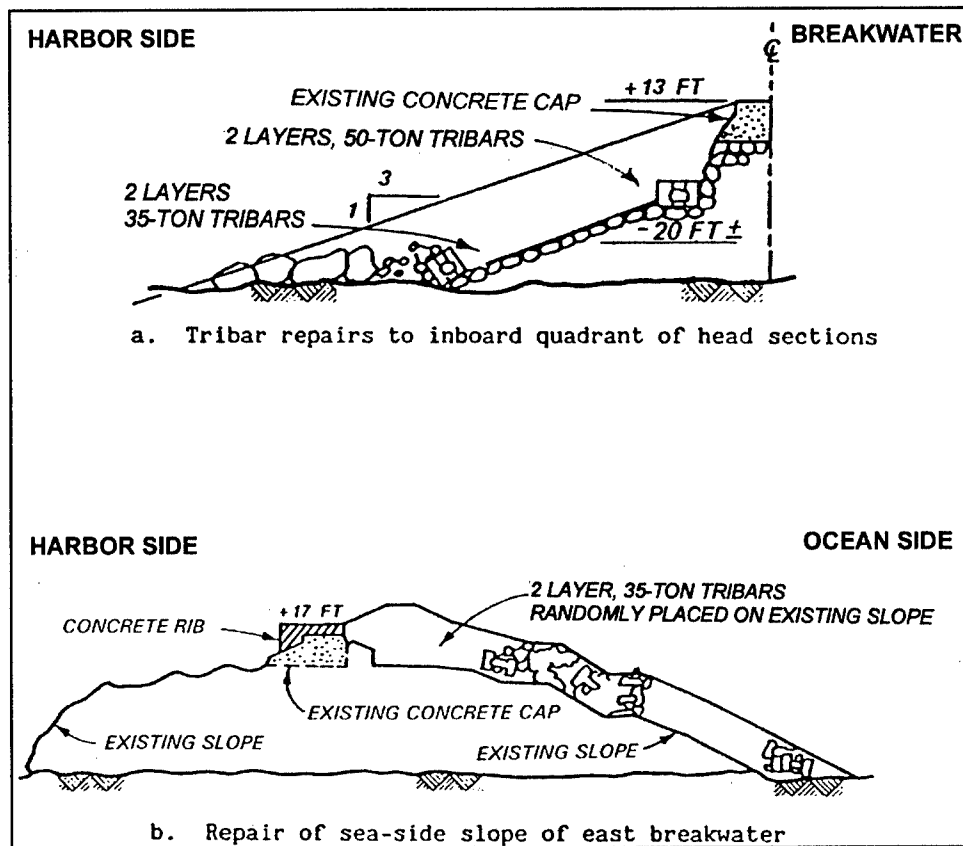

Figure 6. 1996 Kahului breakwater repairs

A storm in 1967 severely damaged the west breakwater trunk. This area was repaired in 1969 by construction of a concrete rib cap and placement of 260 reinforced tribars, weighing 17,235 kg (19 tons) each, on the sea-side slope. In November of the same year, the area adjacent to the 17,235-kg (19-ton) tribars at the shore end was damaged by 4.6- to 6.1-m (15- to 20-ft) breaking waves. This area was repaired in 1973 by a 24.4-m (80-ft) shoreward extension of the concrete rib cap and 17,235-kg (19-ton) tribars. The shoreward extent of the tribars was buttressed with 25 tribars, weighing 31,750 kg (35 tons) each (Figure 7).

An inspection conducted in 1973 revealed that the 29,940-kg (33-ton) tetrapods on the sea-side quadrants of both heads had sustained considerable damage

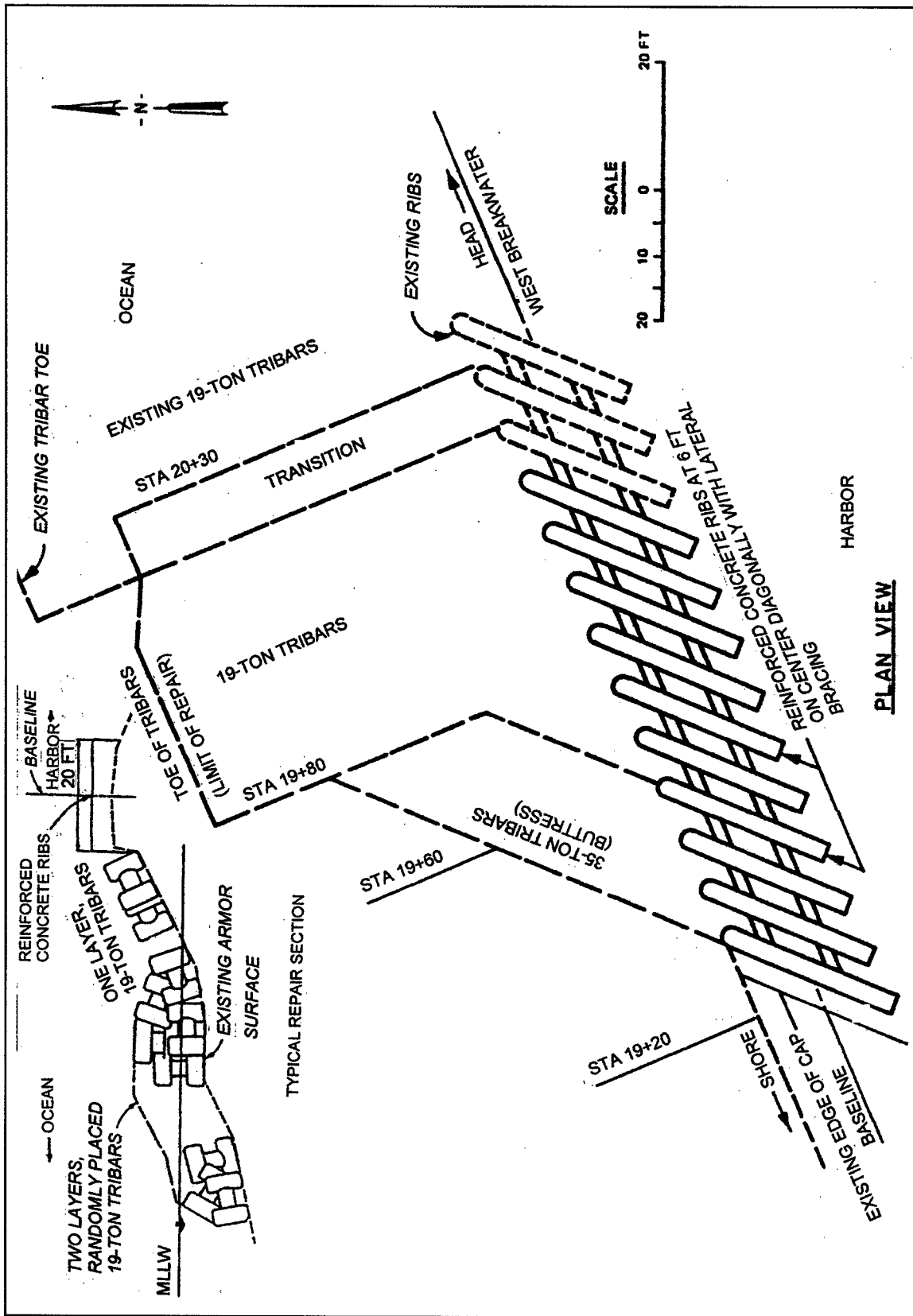

Figure 7. Kahului west breakwater repairs of 1973

and they, along with the 7,257-kg (8-ton) stone areas on both trunks, were in need of repair. The following repairs were completed in 1977: on the west breakwater, 257 reinforced dolosse weighing 27,215 kg (30 tons) each were placed in two layers over the 29,940-kg (33-ton) tetrapods on the sea-side quadrant of the head; 291 reinforced dolosse weighing 18,145 kg (20 tons) each were placed on the sea side of the west breakwater trunk; on the east breakwater, 610 reinforced dolosse weighing 27,215 kg (30 tons) each were placed in a double layer over the 29,940-kg (33-ton) tetrapods on the sea-side quadrant of the head, 164 reinforced dolosse weighing 18,145 kg (20 tons) each were placed in a double layer on the sea-side slope of the trunk beginning shoreward of the 31,750-kg (35-ton) tribars; and, extending shoreward, two layers of 5,445-kg (6-ton) unreinforced dolosse (455 units) were placed on the sea-side slope of the east breakwater trunk.

The most recent repairs, model-studied at ERDC (Markle 1982), were completed in 1984. This rehabilitation was carried out in an attempt to eliminate the need for future piecemeal repairs. On the east breakwater, one layer of 8,165-kg (9-ton) tribars was placed on the harbor side between sta 19+50 and 27+15. In addition, a concrete rib cap was constructed between sta 19+50 and the breakwater head (sta 27+66). On the west breakwater, one layer of 5,900-kg (6.5-ton) tribars was placed on the harbor-side slope from sta 17+75 to 22+00. A single layer of 9,980-kg (11-ton) tribars was also placed on the sea-side slope between sta 17+75 and 19+35. These tribars were buttressed with 22,680-kg (25-ton) tribars at their shoreward end. In addition, a concrete rib cap was constructed from sta 17+75 to 21+65 and tied into the existing concrete cap.

### **Laupahoehoe Point boat-launching facility**

Laupahoehoe Point is located on the northeast coast of the Island of Hawaii (Figure 1) approximately 40 km (25 miles) north-northwest of Hilo. The County of Hawaii's Laupahoehoe Point Park borders the shoreline of Laupahoehoe Point. The park is primarily used for day picnics, family gatherings, and as a tourist scenic attraction and rest stop. Historically, Laupahoehoe boat-launching facility served as a landing where livestock were imported to the area. The park has a concrete loading dock, rest rooms, a picnic area, a pavilion, and a paved parking lot. In addition, a concrete boat-launching ramp was constructed within the park limits in 1970. The launching ramp proved later to be unsafe. It was located within what would appear to be a sheltered cove, but waves reflecting off adjacent rocky shores created hazardous conditions a large percentage of the time. Local fishermen found launching conditions too hazardous even under relatively calm ocean wave conditions. For this reason, the county declared the ramp unsafe and posted a sign, "Boat Ramp Closed."

The waters offshore of Laupahoehoe are very popular and productive for fishing most of the year, but the area was underutilized due to closing of the launching ramp. The closest safe launching area was located in Hilo, 40 km (25 mi) away. This extra travel time required more ice, limiting catch hauling capacity and available hours for fishing. As well as hampering fishing, the

closed ramp severely limited the ability of the Hilo Rescue Squad and U.S. Coast Guard in responding to emergencies on the northeast Hawaii coast.

Plans were developed to improve conditions in the area (U.S. Army Engineer District, Honolulu, 1984). In 1988, a 60.1-m-long (200-ft-long) rubble-mound breakwater protecting a 2.9-m-deep (9.5-ft-deep) entrance channel, 2.3-m-deep (7.5-ft-deep) turning basin, and a boat-launching ramp was completed. The design layout for the facility and stability of the breakwater were optimized through physical model studies conducted at ERDC (Bottin, Markle, and Mize 1987). A layout of the boat-launching facility is shown in Figure 8.

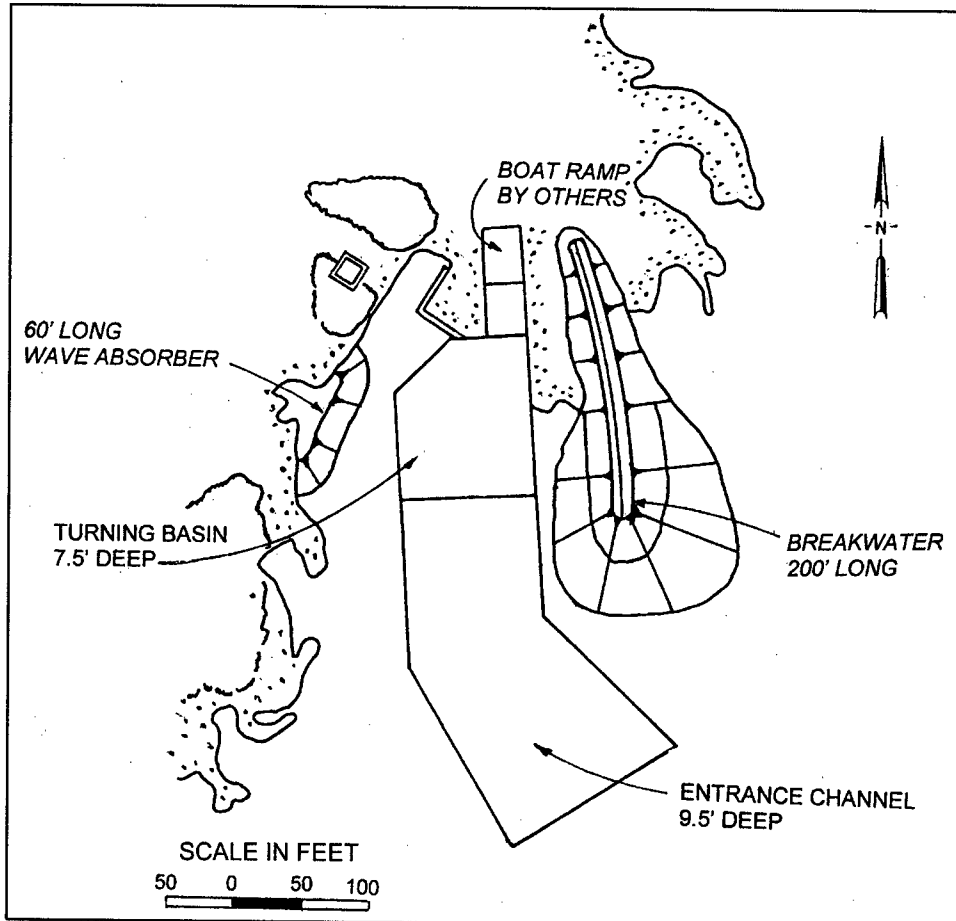

Figure 8. Layout of Laupahoehoe boat-launching facility

The breakwater is armored with 27,215-kg (30-ton) reinforced dolosse and the crest is stabilized with a concrete rib cap. The toe of the dolosse was keyed into the hard basalt bottom by means of a trench excavated around the perimeter of the breakwater. The rib cap is supported on concrete pipe columns. A stable breakwater core was achieved through the innovative design of a reinforced concrete pipe rib cage forming a containment area for core and capstone. A cross section of the breakwater is presented in Figure 9, and an aerial view of the area is shown in Figure 10.

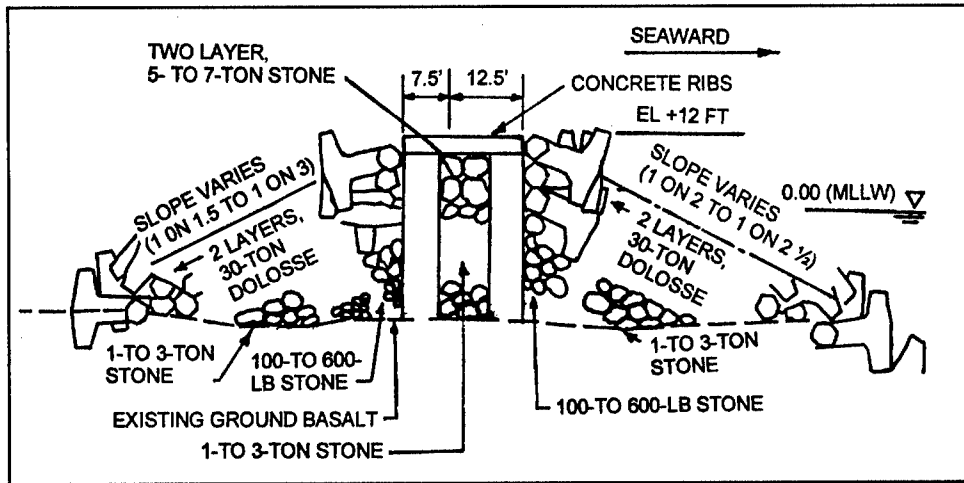

Figure 9. Cross section of Laupahoehoe breakwater



Figure 10. Aerial photograph of Laupahoehoe boat-launching facility (2001)

## Prior Monitoring (Periodic Inspections) of Sites

The Kahului breakwaters were initially monitored during the period October 1991 - August 1993; and the Laupahoehoe breakwater from October 1991 - November 1992 (Markle and Boc 1994) as part of the "Periodic Inspections" Work Unit of the MCNP Program. Work included armor unit targeting, limited ground surveys, aerial photography, and a photogrammetric analyses of armor units. The information obtained during the monitoring effort established base level conditions for the breakwaters. Very precise positions of targeted armor units were obtained. Minimal target movement occurred during the initial monitoring effort. Between October 1991 and August 1993, horizontal and vertical movements of targeted armor units ranged from 0.0 to 0.058 m (0.0 to 0.19 ft) and 0.0 to 0.091 m (0.0 to 0.3 ft), respectively, on the Kahului east breakwater; and from 0.0 to 0.061 m (0.0 to 0.2 ft) and 0.0 to 0.052 m (0.0 to 0.17 ft) on the Kahului west breakwater. On the Laupahoehoe breakwater, horizontal and vertical movements of targeted armor units ranged from 0.0 to 0.046 m (0.0 ft to 0.15 ft) and 0.0 to 0.37 m (0.0 to 0.12 ft), respectively, from October 1991 to November 1992. Average horizontal and vertical movements of targeted armor units, respectively, were 0.021 and 0.021 m (0.07 and 0.07 ft) for the Kahului east breakwater; 0.046 and 0.015 m (0.15 and 0.05 ft) for the Kahului west breakwater; and 0.009 and 0.012 m (0.03 and 0.04 ft) for the Laupahoehoe breakwater.

## Purpose of Current Monitoring

The purposes of the study reported herein were to:

- a. Utilize methodology previously developed using limited land-based surveying, aerial photography, and photogrammetric analysis to assess the long-term stability response of the concrete armor units on the Kahului and Laupahoehoe breakwaters.
- b. Conduct limited land surveys, a broken armor unit inspection, aerial photography, and photogrammetric analyses to accurately define armor unit movement above the waterline.
- c. Compare the breakwater's armor unit positions to those obtained during the surveys completed in 1992/1993 and define changes that have occurred.

## 2 Monitoring Plan and Data Comparison

---

The objective of the current monitoring effort in the "Periodic Inspections" Work Unit was to re-examine the targeted concrete armor units on the outer portions of the Kahului east and west breakwaters, and the Laupahoehoe breakwater, and determine changes that have occurred since the last inspections in 1992-1993. The monitoring plan consisted of targeting armor units, limited ground surveys, aerial photography, photogrammetric analysis of armor unit locations, ground-based broken armor unit surveys, and comparisons of current armor unit positions with those obtained previously.

### Targeting and Ground Surveys

To serve as control for the ground-based surveys as well as the photogrammetric work, existing monuments from previous surveys were located and resurveyed using Trimble real-time kinematic global positioning system equipment and electronic surveying techniques. Monuments at the sites used to establish vertical and horizontal control are shown in Figures 11 and 12 for the Kahului and Laupahoehoe projects, respectively.

In addition, targets were re-established on concrete armor units. As previously reported (Markle and Boc 1994), 10 targeted armor units were monitored on the Kahului east breakwater, 10 on the Kahului west breakwater, and five on the Laupahoehoe breakwater. A description of the targeted units is presented in Table 1. On the Kahului east breakwater, two of the targeted units were 8,165-kg (9-ton) tribars, five were 27,215-kg (30-ton) dolos, two were 31,750-kg (35-ton) tribars, and one was a 5,445-kg (6-ton) dolos. On the Kahului west breakwater, two of the targeted units were 5,900-kg (6.5-ton) tribars, one was a 9,980-kg (11-ton) tribar, five were 27,215-kg (30-ton) dolos, and two were 31,750-kg (35-ton) tribars. All five units targeted on the Laupahoehoe breakwater were 27,215-kg (30-ton) dolos. Units were distributed on the sea and harbor sides of the breakwaters as well as around their heads, and from the breakwater crest to the waterline. Figures 13-15 show the locations of targeted armor units on the Kahului east and west breakwaters and the Laupahoehoe breakwater, respectively.

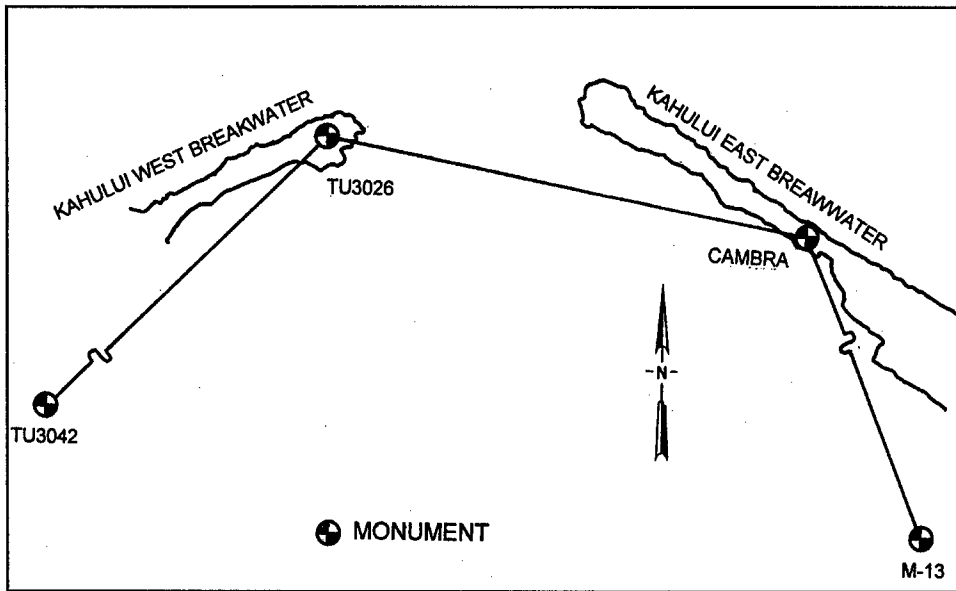

Figure 11. Monuments used to establish survey control at Kahului Harbor

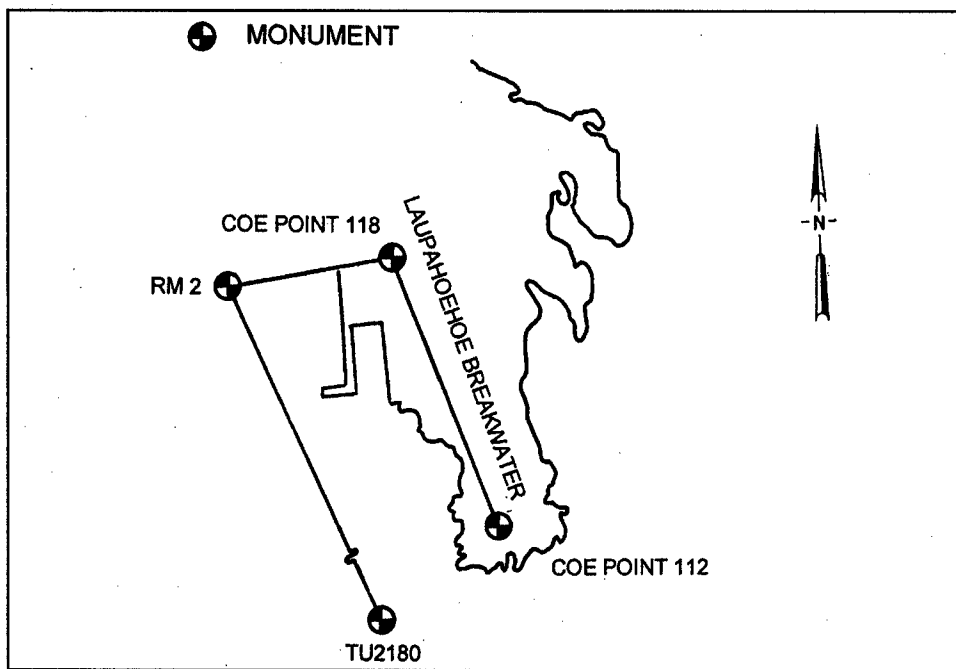

Figure 12. Monuments used to establish survey control at Laupahoe boat-launching facility

Units were originally chosen for targeting in 1991 that had flat surfaces close to horizontal to maximize their visibility in aerial photography and allow for accurate representation of armor unit movement. Each armor unit selected for targeting was painted with three, 30.5-cm- (12-in.-) diam targets. The targets were divided into four quadrants that were painted alternately white and black. This style of contrasting target provides a precise center point for which

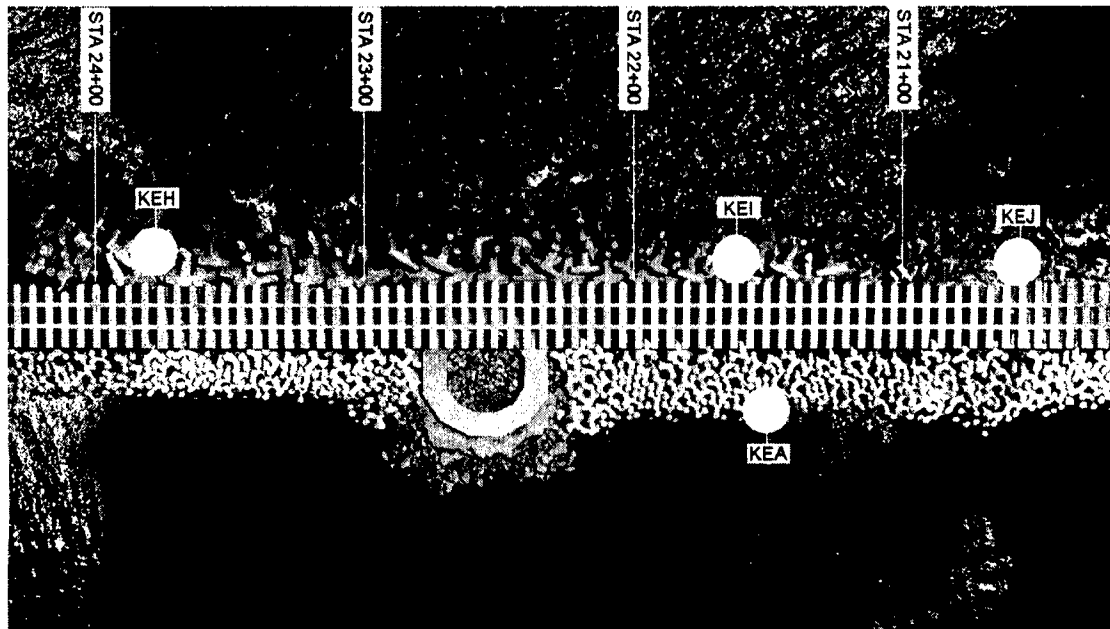
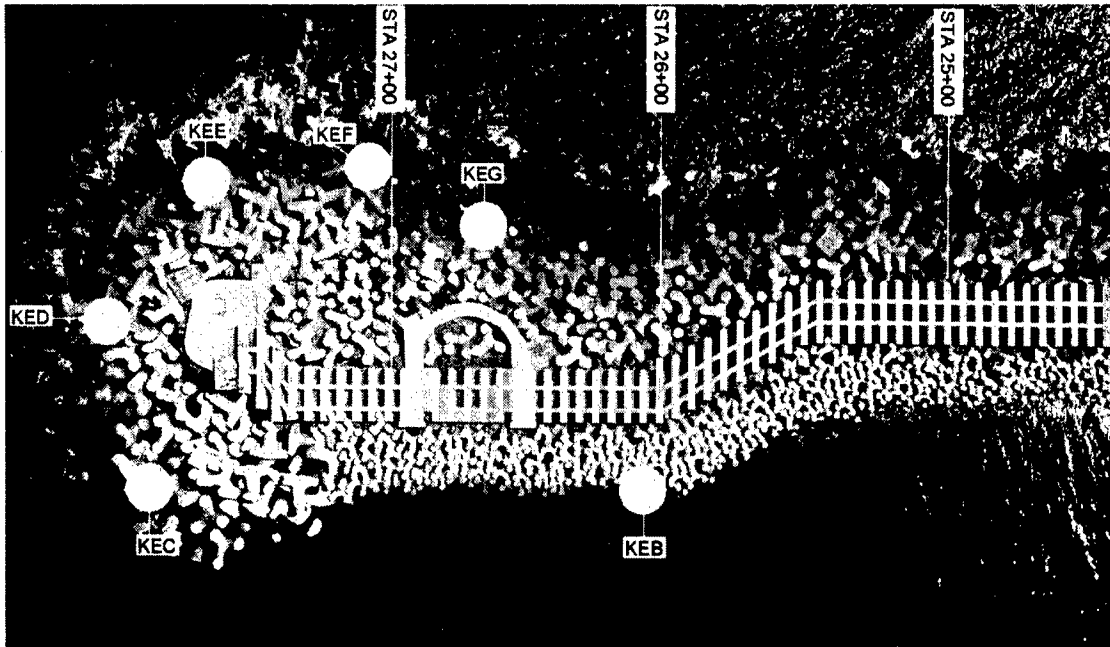

Figure 13. Locations of targeted armor units on Kahului east breakwater

measurements can be made by both land surveys and photogrammetric work. A high quality epoxy-based marine paint was used to minimize the need for repainting, and a 2.54-cm- (1-in.-) cross was chiseled at the center of each target for identification in subsequent surveys. Each targeted unit was labeled conspicuously with 15.2-cm- (6-in.-) high white-lettered alphanumeric characters. The alpha characters identify the unit and the breakwater in which it resides, and the

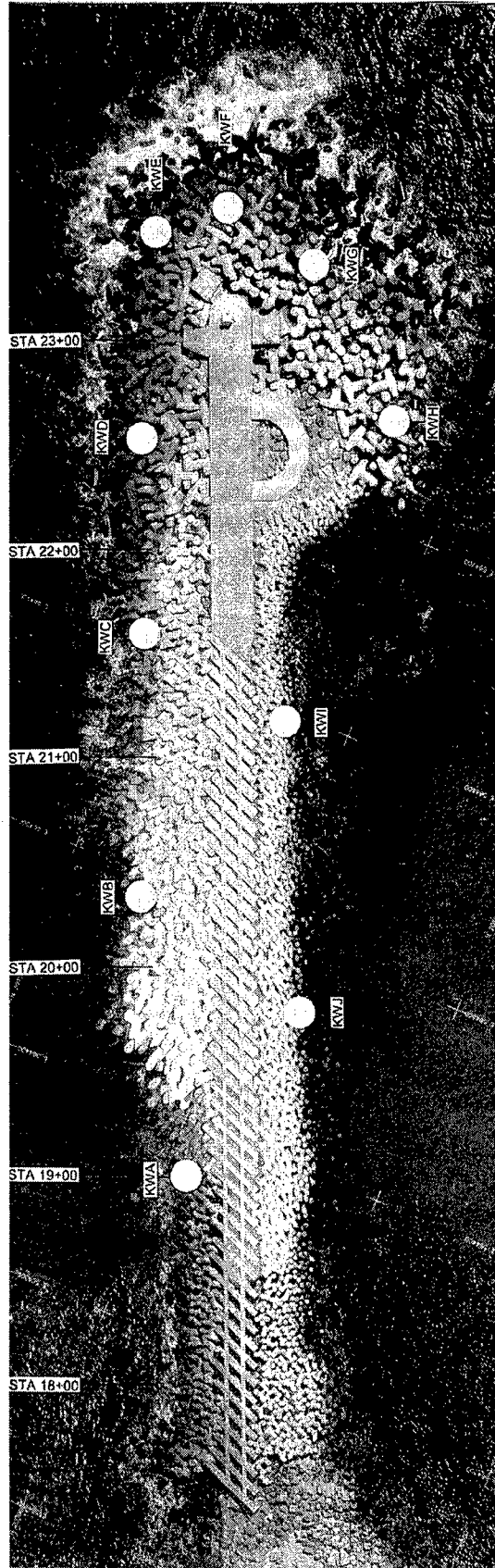

Figure 14. Locations of targeted armor units on Kahului west breakwater

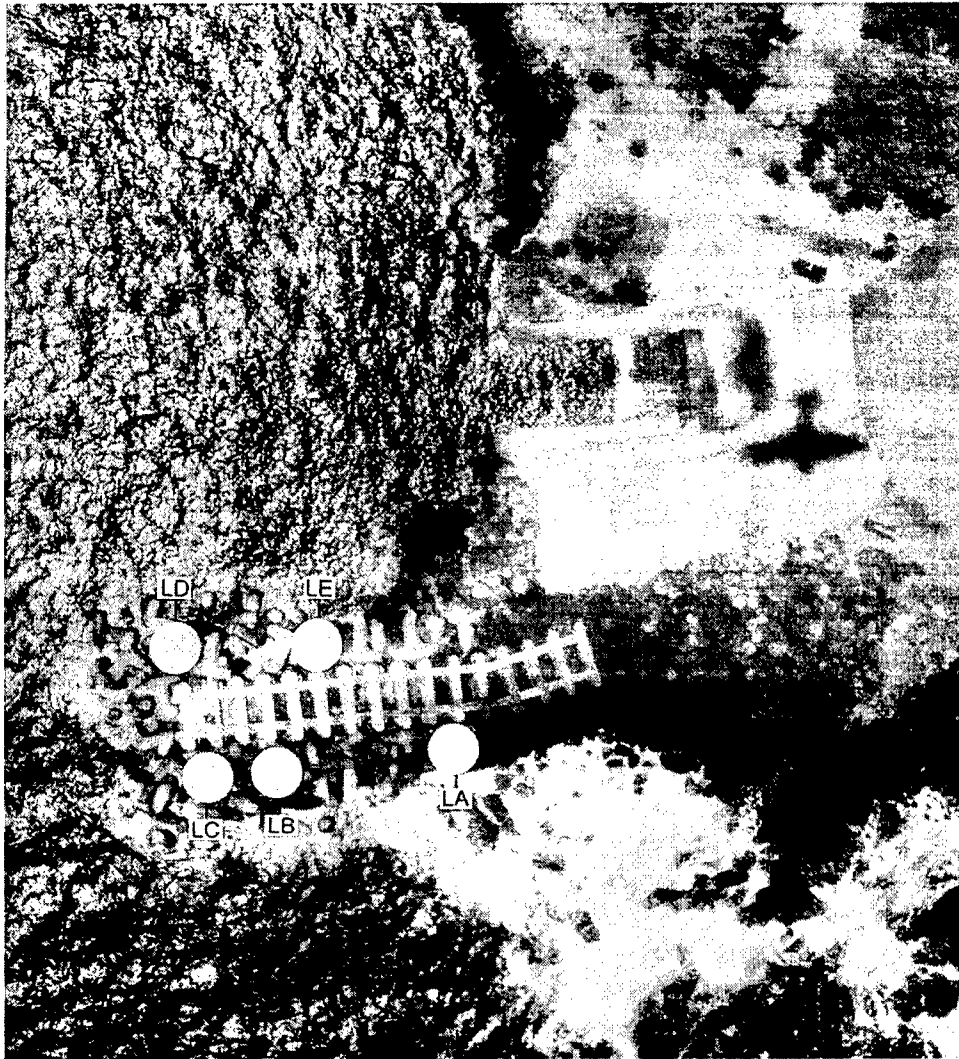

Figure 15. Locations of targeted armor units on Laupahoehoe breakwater

numeric characters identify the target on the armor unit. For example, armor unit “KEA” indicates a unit on the Kahului east breakwater that is unit A of 10 units (A through J) targeted on the breakwater. The unit has three targets labeled KEA-1, KEA-2, and KEA-3. An example of a targeted armor unit is shown in Figure 16.

Limited ground surveys of some of the concrete armor unit targets were conducted in August 2001 to serve as control to check the accuracy of the subsequent photogrammetric work. Target coordinates were established using a Wild T-2000 total station surveying instrument. Horizontal positions were based on the Hawaii State Plane Coordinate System, Zone 2 for Kahului and Zone 1 for Laupahoehoe. Elevations at both sites were referenced to mean lower low water (mllw) datum.



Figure 16. Example of targeted tribar

## Aerial Photography

Aerial photography is an effective means of capturing images of large areas for later analysis, study, visual comparison to previous or subsequent photography, or measurement and mapping. Its chief attribute is the ability to freeze a moment in time, while capturing extensive detail.

Aerial photography was obtained along the Kahului and Laupahoehoe breakwaters with a Zeiss RMK A 15/23 aerial mapping camera (9-in. by 9-in. format). Color photos were secured from a fixed-wing aircraft flying at an appropriate altitude, which resulted in high resolution images and contact prints with scales of 1:1,200. Photographic stereo pairs were obtained during the flights. Stereo pairs secured for the Kahului east and west breakwaters and the Laupahoehoe breakwater are shown in Figures 17-21. Aerial photography was obtained at Kahului on 26 August 2001 and at Laupahoehoe on 5 September 2001.

## Photogrammetric Analysis of Armor Unit Targets

When aerial photography is planned and conducted so that each photo image overlaps the next by 60 percent or more, the two photographs comprising the overlap area can be positioned under an instrument called a stereoscope, and viewed in extremely sharp three-dimensional (3-D) detail. If properly selected survey points on the ground have previously been targeted and are visible in the overlapping photography, accurate measurements of any point appearing in the photographs can be obtained. This technique is called photogrammetry.

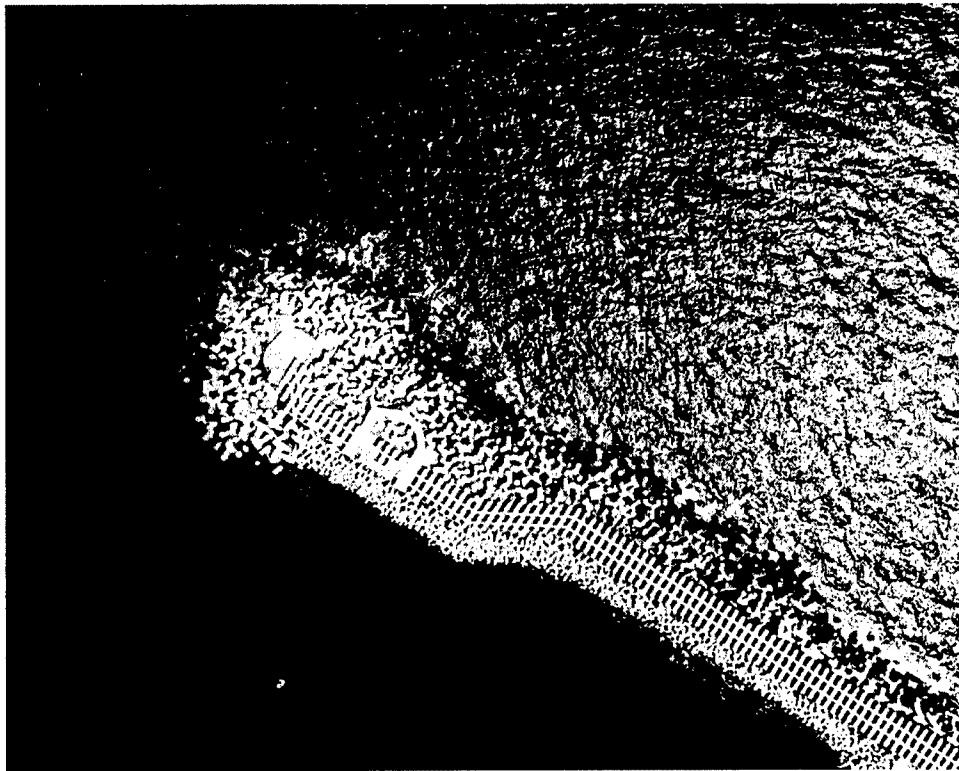
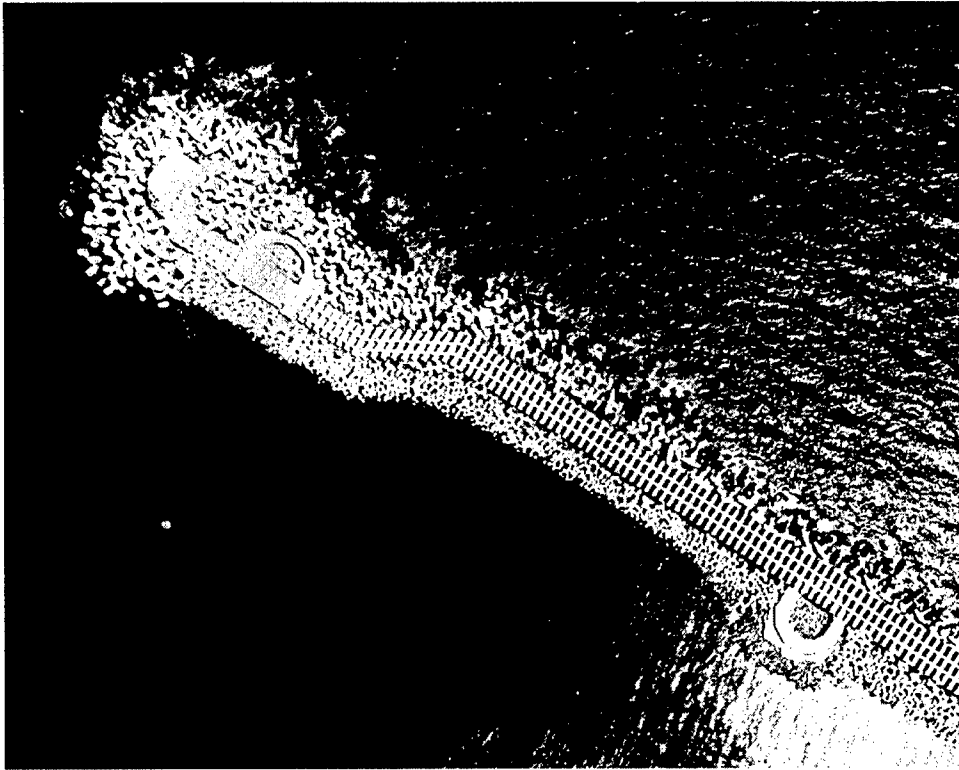

Figure 17. Stereo pair photographs of outer portion of Kahului east breakwater

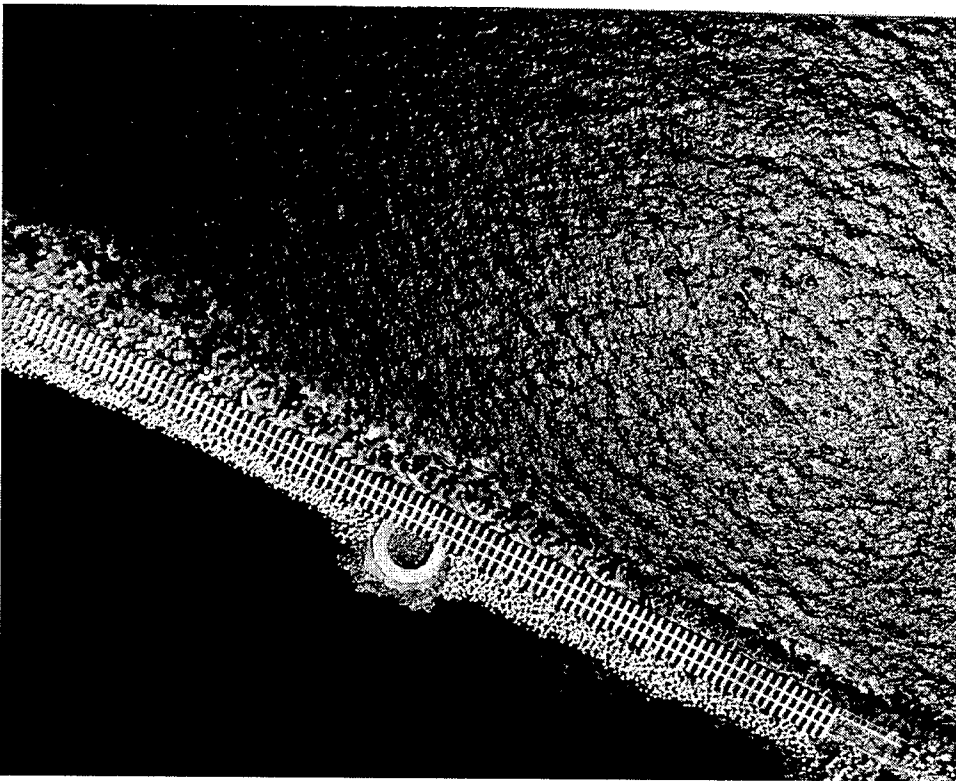
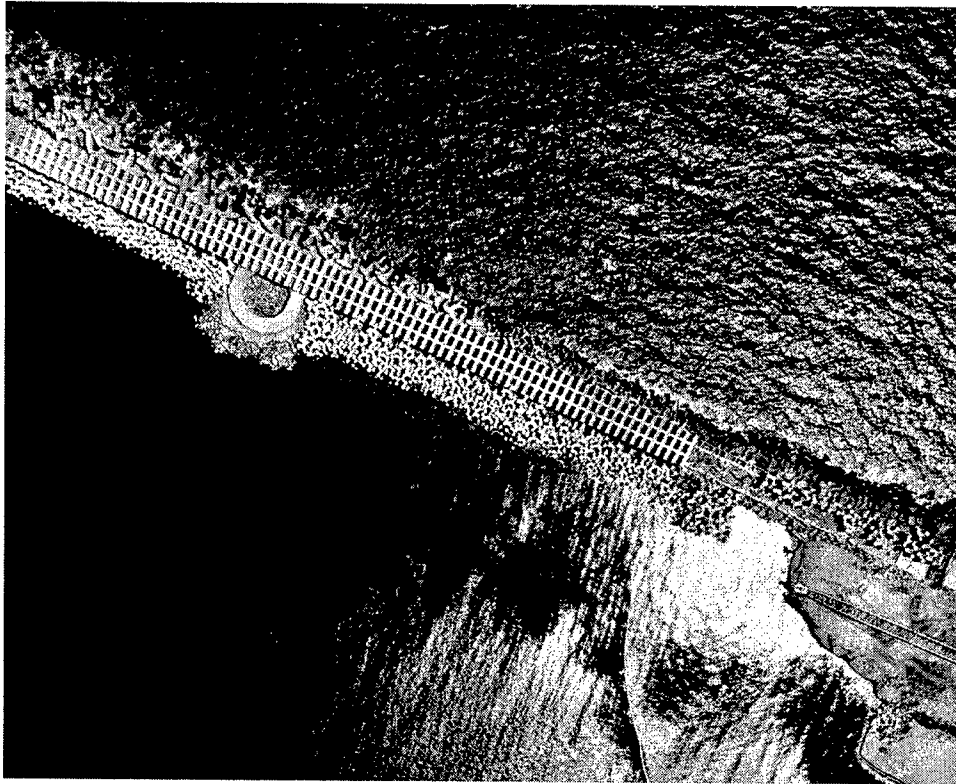

Figure 18. Stereo pair photographs of inner portion of Kahului east breakwater

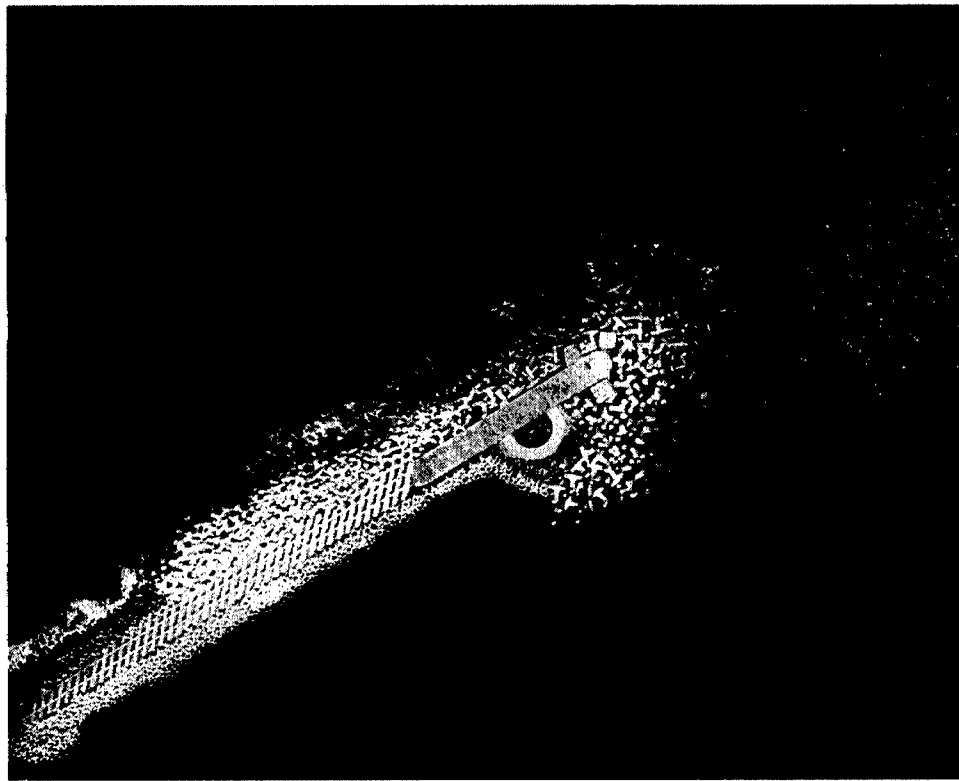
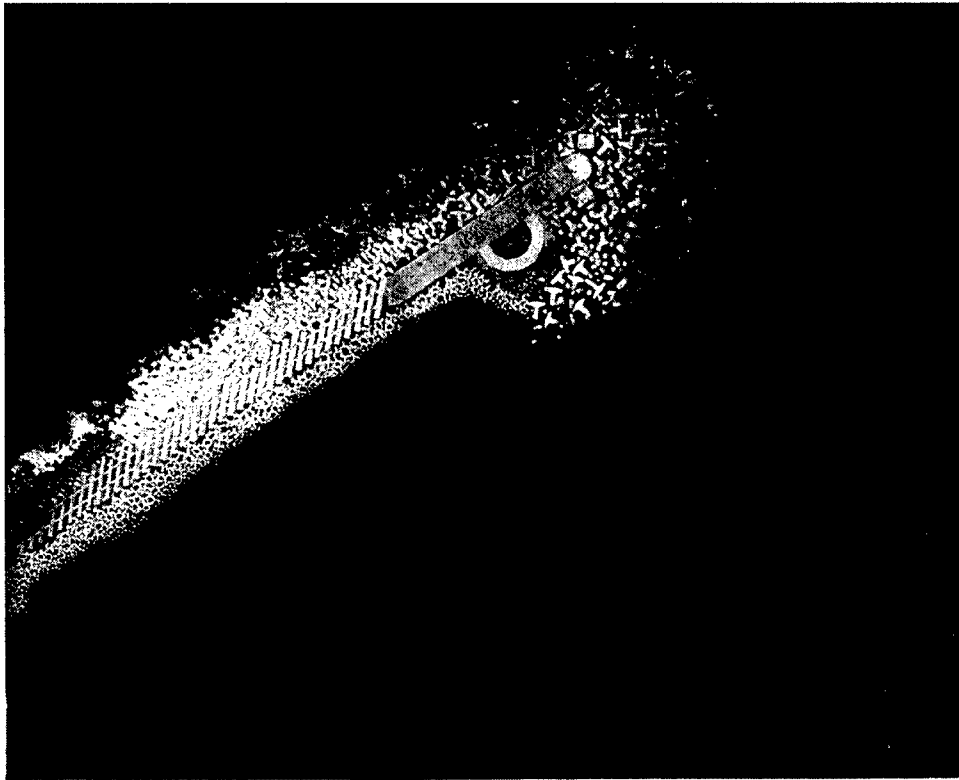

Figure 19. Stereo pair photographs of outer portion of Kahului west breakwater

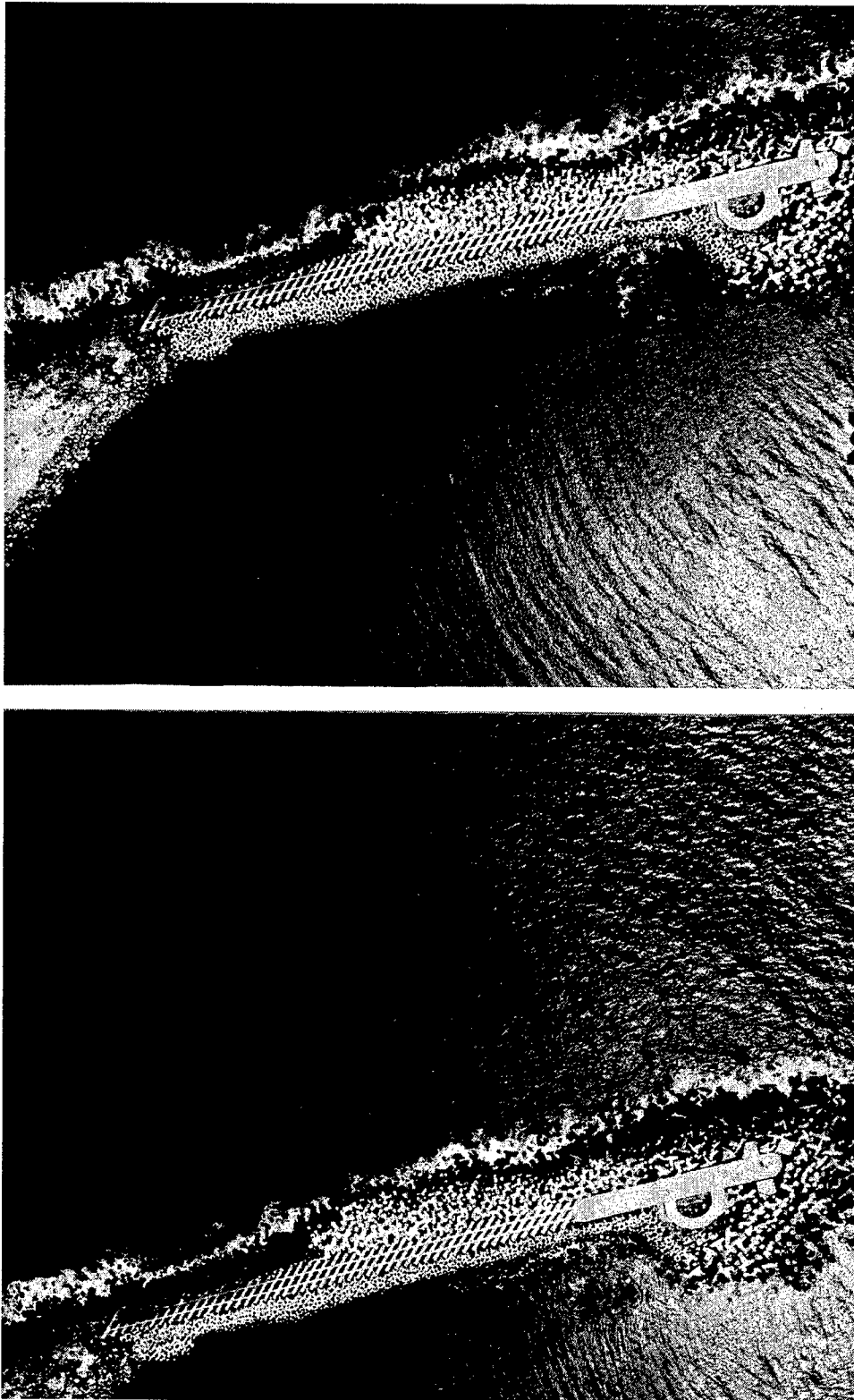

Figure 20. Stereo pair photographs of inner portion of Kahului west breakwater

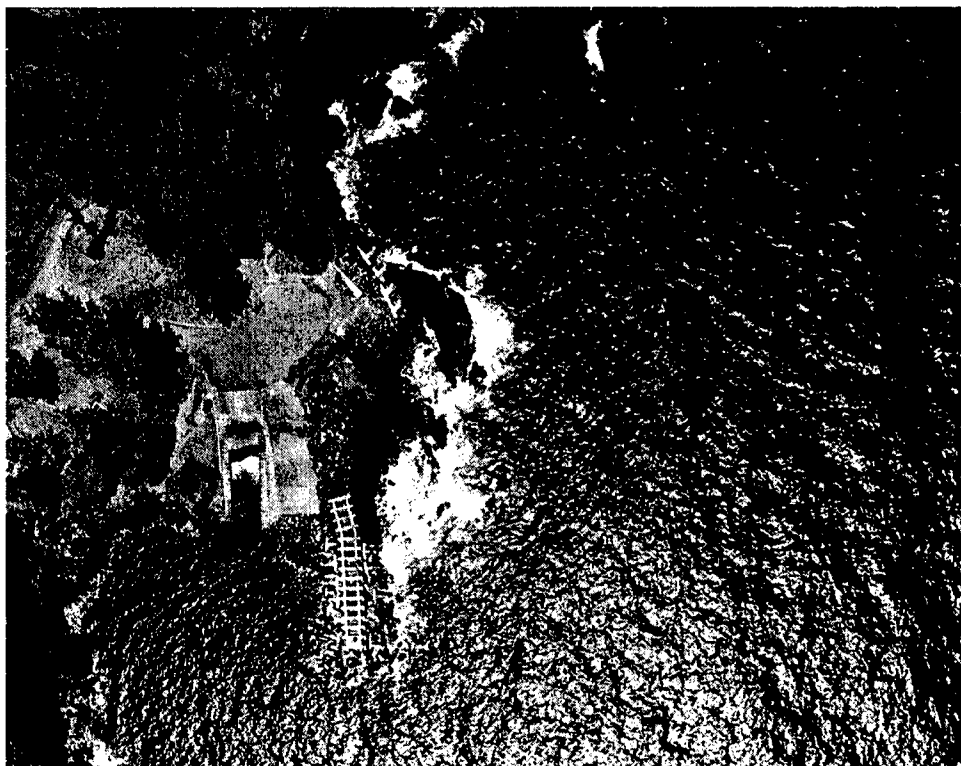

Figure 21. Stereo pair photographs of Laupahoehoe breakwaters

The stereo pair images obtained during aerial photography at Kahului and Laupahoehoe breakwaters were viewed in a Zeiss P-3 Analytical Stereoplotter, and stereomodels were oriented to the ground control point data previously obtained. In the stereomodel, accurate horizontal and vertical measurements can be made of any point on any armor unit appearing in the print. The stereomodel was used for all photogrammetric compilation and the development of photo maps. To establish the accuracy of the photogrammetric work, comparisons of the coordinates for selected targets obtained during the ground surveys with those of the aerial surveys (stereomodels) were conducted and indicated very close agreement. For the Kahului east breakwater, maximum differences were 0.098 and 0.067 m (0.32 and 0.22 ft), respectively, for the horizontal and vertical positions. An average of all horizontal and vertical positions indicated differences of 0.027 m (0.09 ft) and 0.03 m (0.1 ft), respectively. For the Kahului west breakwater, maximum differences were 0.061 and 0.037 m (0.2 and 0.12 ft), respectively, for the horizontal and vertical positions. An average of all horizontal and vertical positions indicated differences of 0.024 m (0.08 ft) and 0.024 m (0.08 ft), respectively. For the Laupahoehoe breakwater, maximum differences were 0.043 and 0.024 m (0.14 and 0.08 ft), respectively, for the horizontal and vertical positions. An average of all horizontal and vertical positions indicated differences of 0.021 m (0.07 ft) and 0.009 m (0.03 ft), respectively.

A photogrammetric analysis of the targeted armor units was conducted for the Kahului east and west breakwaters and the Laupahoehoe breakwater, and x, y, and z (easting, northing, and el) coordinates were obtained. Data obtained during the current (August/September 2001) surveys were compared to those obtained at Kahului and Laupahoehoe during the aerial surveys of August 1993 and November 1992, respectively. Comparisons of the aerial survey data are presented in Tables 2-4.

For the Kahului east breakwater, comparisons of target coordinates (Table 2) show relatively close agreement between the two surveys for most of the targets. Maximum movement in the horizontal and vertical directions was 0.933 m (3.06 ft) and 1.515 m (4.97 ft), respectively, however, this level of difference occurred for only one target for the horizontal (KEE2) and one target in the vertical (KED1) position. Both these units (KED and KEE) are situated around the seaward head of the structure. The average movement of all horizontal and vertical targets, respectively, was 0.155 m (0.51 ft) and 0.165 m (0.54 ft). If the extreme horizontal and vertical movements of targets KEE2 and KED1 are neglected, average movement was 0.143 m (0.47 ft) and 0.113 m (0.37 ft), respectively, for the horizontal and vertical targets. Even though targets on armor units KEE and KED have moved about 0.91 to 1.52 m (3 to 5 ft), respectively, visual observations indicate the units have not broken and continue to be functional. Note in Table 2 that no data are presented for target KEE3 and KEJ2. Armor unit KEE moved slightly horizontally and the target was not visible from the air since it was blocked by an adjacent armor unit. Accessibility to target KEJ2 was difficult due to wave action and re-establishment of the target was inadvertently missed.

For the Kahului west breakwater, comparisons of target coordinates (Table 3) also show relatively close agreement between the 1993 and 2001 surveys for most of the targets. Maximum movement in the horizontal and vertical directions was 1.158 m (3.8 ft) and 0.582 m (1.91 ft), respectively; however, this level of difference occurred on only one armor unit (KWH). This unit is located on the harbor-side head of the structure. Visual observations revealed the armor unit was intact and functional. The average movement of all horizontal and vertical targets, respectively, was 0.128 m (0.42 ft) and 0.11 m (0.36 ft).

For the Laupahoehoe breakwater, comparisons of target coordinates (Table 4) reveal close agreement between the surveys indicating minimal horizontal and vertical movement of the targeted concrete armor units. Maximum movement in the horizontal and vertical directions was 0.104 m (0.34 ft) and 0.131 m (0.43 ft), respectively. The average movement of all horizontal and vertical targets, respectively, was 0.03 m (0.1 ft) and 0.049 m (0.16 ft).

With the x, y, and z (easting, northing, and elevation) coordinates defined for each target on the various armor units, the coordinates of the centroid (center of mass) of each targeted armor unit were computed for the 2001 aerial survey. In addition, the position of each armor unit relative to the x, y, and z axes was determined and compared with previous data. Figure 22 shows, in three dimensions, the orientation and comparison of representative armor units to the three axes for the two surveys. The centroid coordinates of each targeted armor unit on the Kahului east and west breakwaters and the Laupahoehoe breakwater are shown in Tables 5-7 and compared with the aerial survey results of 1992/1993. Maximum movement of the centroids for the Kahului east breakwater was 0.536 m (1.76 ft) and 0.671 m (2.2 ft) in the horizontal and vertical directions, respectively, while average movements were 0.119 m (0.39 ft) and 0.17 m (0.57 ft) in the horizontal and vertical directions. As noted earlier, data were not obtained for two targets (KED1 and KEE2) on the Kahului east breakwater, however, based on information available and known dimensions of these armor units, their centroid positions were calculated. For the Kahului west breakwater, maximum horizontal and vertical centroid movements, respectively, were 0.64 m (2.1 ft) and 0.186 m (0.61 ft), while average movements were 0.113 (0.37 ft) and 0.64 m (0.21 ft) in the horizontal and vertical directions. Maximum movement of the centroids for the Laupahoehoe breakwater was 0.091 m (0.3 ft) and 0.085 m (0.28 ft) in the horizontal and vertical directions, respectively, while average movements were 0.03 m (0.1 ft) and 0.034 m (0.11 ft) in the horizontal and vertical directions. The targeted armor units' orientation (rotation angle relative to the x, y, and z axes) are presented in Tables 8-10 for the east and west Kahului breakwaters and the Laupahoehoe breakwater and compared with the aerial survey results of 1992/1993. For the Kahului east breakwater, changes in the rotation angle of the targeted armor units varied from 0.03 to 24.57 deg with an average of 3.09 deg. Changes in rotation angles varied from 0.0 to 17.32 deg for the Kahului west breakwater with an average of 2.02 deg. For the Laupahoehoe breakwater, changes in rotation angles varied from 0.01 to 0.36 deg with an average of 0.1 deg.

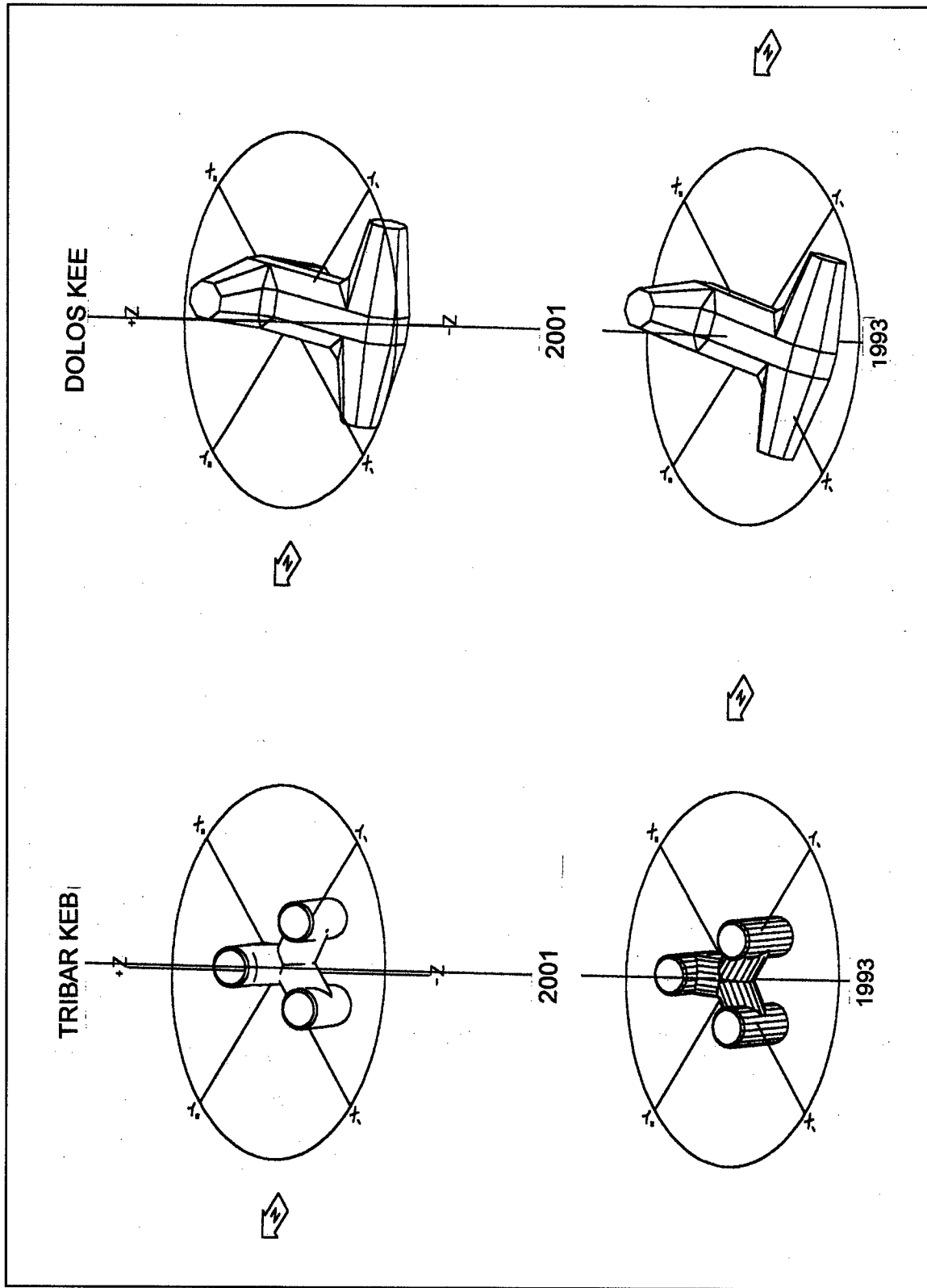

Figure 22. Comparison of representative targeted armor unit position relative to x, y, and z axes

Photo maps combine the image characteristics of a photograph with the geometric qualities of a map. The image is rectified and free from skewness and distortion, and therefore, precise horizontal measurements may be obtained using an engineer scale. Photo maps were prepared for the outer portions of the Kahului east and west breakwaters and the Laupahoehoe breakwater for the 2001 survey. They were produced on mylar sheets at a scale of 1:240. Examples of photo maps for the Kahului east and west breakwater heads and the Laupahoehoe breakwater are shown in Figures 23-25. In an effort to quantify horizontal movement of nontargeted concrete armor units on the Kahului and Laupahoehoe breakwaters, photo maps obtained for the 1992/1993 and 2001 were compared. Eight 27,215-kg (30-ton) dolosse around the seaward quadrant of the head of the Kahului east breakwater (including targeted units KED and KEE) appeared to have slightly changed positions. Movement appeared to be on the order of 0.3 to 0.9 m (1 to 3 ft). These units have not broken and are considered functional. Just a few additional units on the remaining portion of the Kahului east breakwater, as well as on the Kahului west breakwater, had moved slightly with no concentrations in any specific areas. Negligible movement of nontargeted units on the Laupahoehoe breakwater was detected between the surveys.

In summary, detailed and accurate information relative to the armor unit positions for the Kahului and Laupahoehoe breakwaters have been captured by means of aerial photography and photogrammetric analysis. Comparisons of 2001 target data to that obtained previously in 1993 for the Kahului breakwaters indicated horizontal movements ranging from 0.0 to 0.933 m (0.0 to 3.06 ft) and 0.0 to 1.158 m (0.0 to 3.8 ft) for the east and west breakwaters, respectively, and vertical movements ranging from 0.003 to 1.515 m (0.01 to 4.97 ft) and 0.018 to 0.582 m (0.06 to 1.91 ft). Additional comparisons of 2001 centroid data to that of 1993 revealed horizontal movements ranging from 0.003 to 0.536 m (0.01 to 1.76 ft) and 0.0 to 0.64 m (0.0 to 2.1 ft) for the east and west breakwaters, respectively, and vertical movements ranging from 0.015 to 0.671 m (0.05 to 2.2 ft) and 0.0 to 0.186 m (0.0 to 0.61 ft). Comparisons of 2001 target data to that obtained at the Laupahoehoe breakwater in 1992, indicated horizontal movements ranging from 0.003 to 0.104 m (0.01 to 0.34 ft) and vertical movements ranging from 0.0 to 0.131 m (0.0 to 0.43 ft). Comparisons of centroid data at Laupahoehoe revealed horizontal movements ranging from 0.0 to 0.091 m (0.0 to 0.3 ft) and vertical movements ranging from 0.003 to 0.085 m (0.01 to 0.28 ft). Comparisons of nontargeted armor units on the rectified photo maps of the breakwaters indicated movement of several units along the sea-side quadrant of the Kahului east breakwater. Movement was on the order of 0.3 to 0.9 m (1 to 3 ft), however, the units were intact and considered functional. On the Kahului west breakwater a few units had moved slightly with no concentrations in any specific area. Negligible movement occurred on the Laupahoehoe breakwater.

Full-scale hard copies of aerial photographs and photo maps are on file at the authors' offices at CHL and the Honolulu District. In addition, all photogrammetric compilations and analyses have been stored on diskettes in MICROSTATION files for future use. Data are stored and can be retrieved and compared against data obtained during subsequent monitoring. Thus, armor unit movement may continue to be quantified precisely in future years.

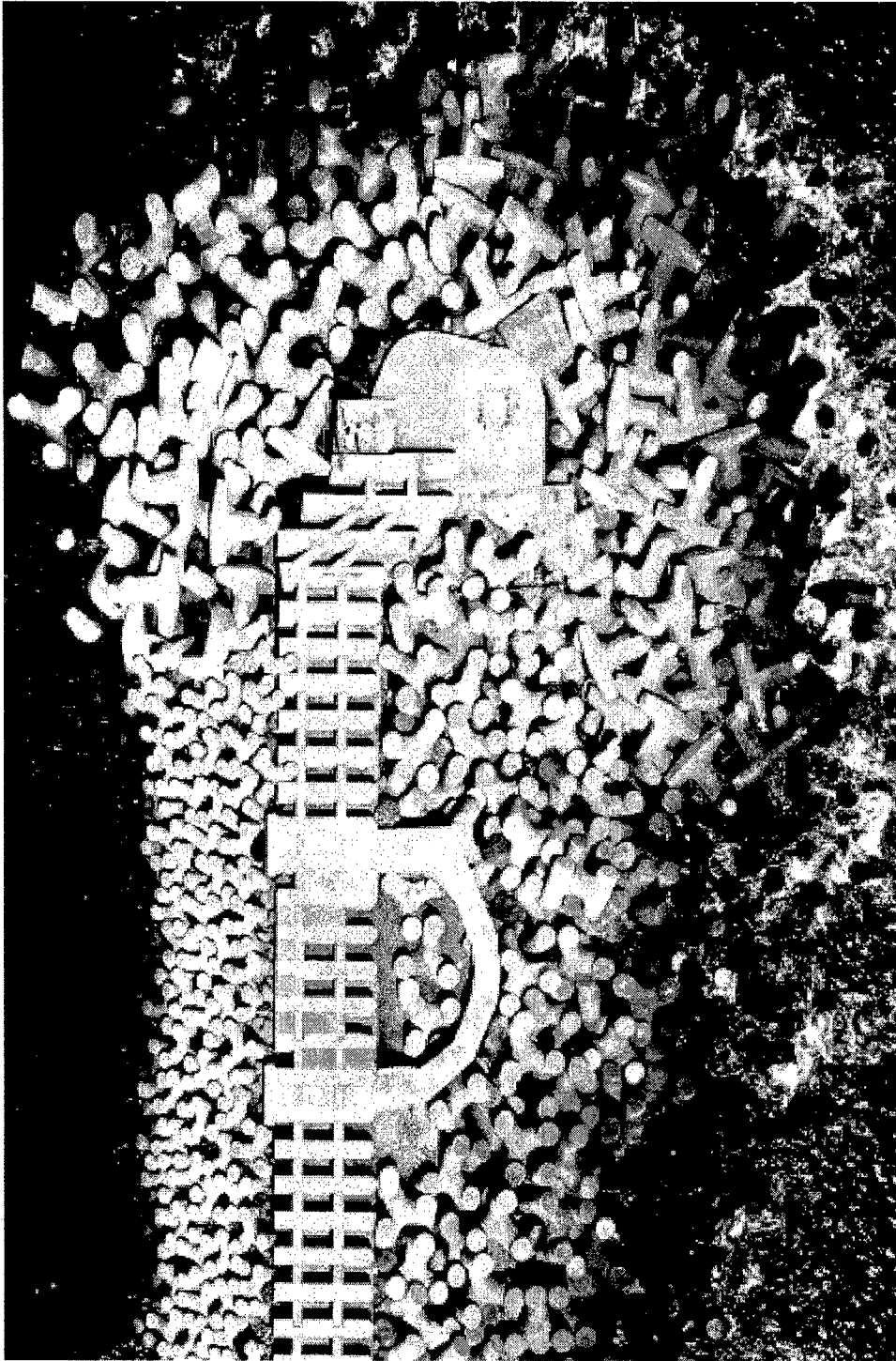

Figure 23. Photo map of head of Kahului east breakwater



Figure 24. Photo map of head of Kahului west breakwater

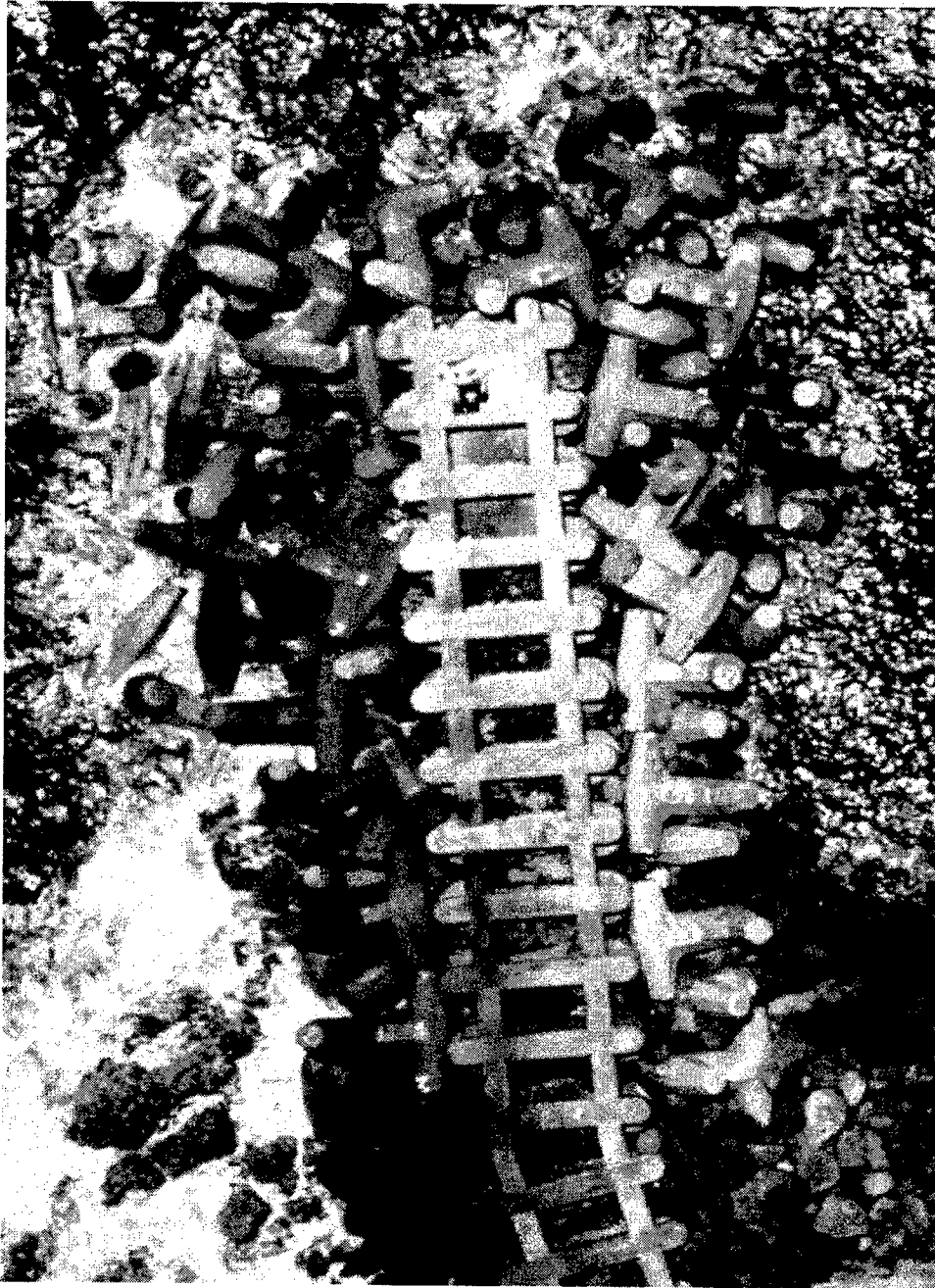

Figure 25. Photo map of Laupahoehoe breakwater

## Broken Armor Unit Surveys

During the period 21-23 August 2001, a survey of broken/cracked armor units above the waterline was conducted for the Kahului east and west breakwaters and Laupahoehoe breakwater. During the inspection, each broken armor unit was identified and photographed, and its approximate location relative to breakwater station and distance from a baseline was recorded. The baseline was the approximate center line of the structure. On the Kahului east breakwater,

29 broken or cracked armor units were identified and 58 were observed on the Kahului west breakwater during the walking survey. No broken or cracked armor units were found on the Laupahoehoe breakwater .

The approximate locations of broken/cracked armor units along the Kahului east and west breakwaters are shown in Figures 26 and 27, respectively, and detailed data obtained during the broken armor unit inventory are shown in Table 11. Armor unit numbers identified in Figures 26 and 27 correspond to those listed in Table 11. Of the 29 broken armor units on the Kahului east breakwater, 19 were 5,445-kg (6-ton) dolosse; two were 8,165-kg (9-ton) tribars; four were 27,215-kg (30-ton) dolosse; and four were 31,750-kg (35-ton) tribars. The majority of the broken units (66 percent) were 5,445-kg (6-ton) dolosse located on the seaward side of the inner half of the concrete-armored portion of the structure. These broken units were concentrated between stas 19+60 and 20+84. Seventy-four percent of the broken 5,445-kg (6-ton) dolosse were located on the lower portion of the seaward slope in the active wave zone. Most the remaining broken units on the east breakwater were sporadically located around the head of the structure with no specific concentrations. Of the 58 broken armor units on the Kahului west breakwater, four were 5,900-kg (6.5-ton) tribars; one was a 9,980-kg (11-ton) tribar; 16 were 17,235-kg (19-ton) tribars; 18 were 18,145-kg (20-ton) dolosse; 11 were 27,215-kg (30-ton) dolosse; five were 29,940-kg (33-ton) tetrapods; and three were 31,750-kg (35-ton) tribars. On the west breakwater, 90 percent of the broken units were located on the seaward side of the outer half of the concrete-armored section of the breakwater. Concentrations of broken units occurred on the sea side of the breakwater between stas 20+50 and 21+50 and stas 22+50 and 23+50. Most broken units (66 percent) also were located on the lower portion of the seaward breakwater slope in the active wave zone.

Types of breaks for the dolosse included shank and fluke breaks. These were characterized as mid-shank, shank-fluke (shank broken in vicinity of fluke), and fluke-shank (fluke broken off at junction with shank). Also recorded were straight breaks (broken straight across) and angled breaks (broken at some angle to the dolos limb). For the tribars and tetrapods, types of breaks included those through the center section of the unit where one or more legs were separated from the unit, and those in which just a portion of one of the legs was broken off.

Views of representative types of breaks for the armor units are shown in Figures 28-31. Armor units with hairline cracks on one side were not counted, only those that were cracked all the way through were considered a break for recording purposes.

Considering the types of breaks for the 52 broken dolosse on both the Kahului structures, 75 percent had shank-fluke breaks, 16 percent had fluke-shank breaks, and 9 percent had mid-shank breaks. Of the dolosse breaks recorded, 78 percent were straight and 22 percent were angled. Considering the types of breaks for the 35 tribars and tetrapods on the Kahului breakwaters, 89 percent included units with breaks through the center sections where one or more legs had separated, and 11 percent had just portions of a leg broken off the unit.

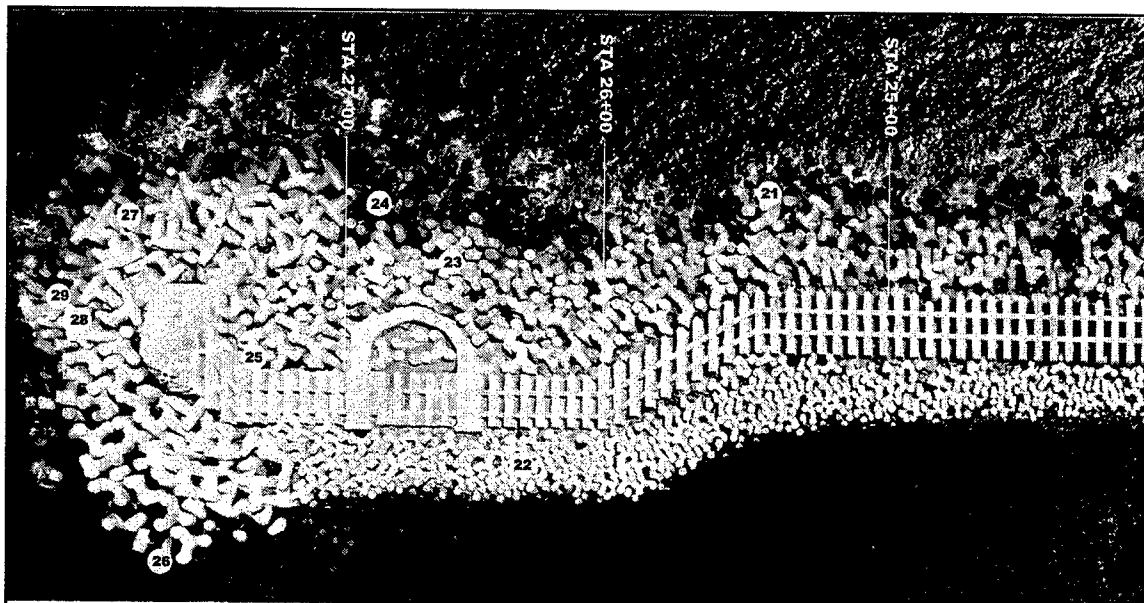

Seaward portion of concrete-armed section

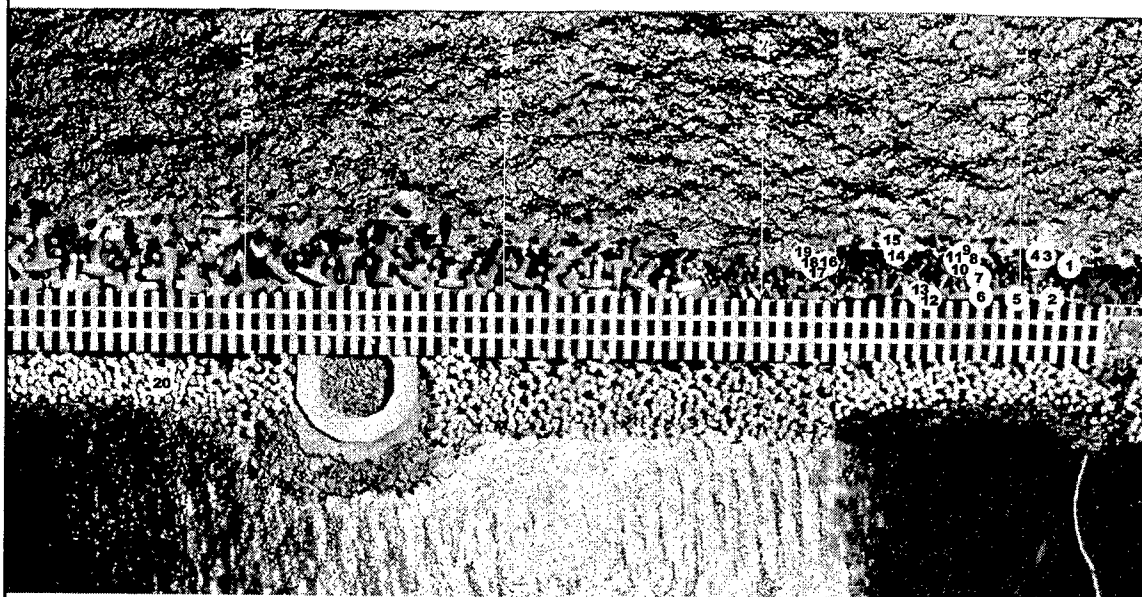

Landward portion of concrete-armed section

Figure 26. Approximate locations of broken/cracked armor units along outer portion of Kahului east breakwater

During the previous study, documentation of broken/cracked armor units by foot was not conducted as part of the periodic inspection. Instead, low-level helicopter inspections were made of the Kahului and Laupahoehoe breakwaters in April 1992, to obtain a count of visible armor unit breakage. Findings revealed three broken armor units on the Kahului east breakwater, 13 on the

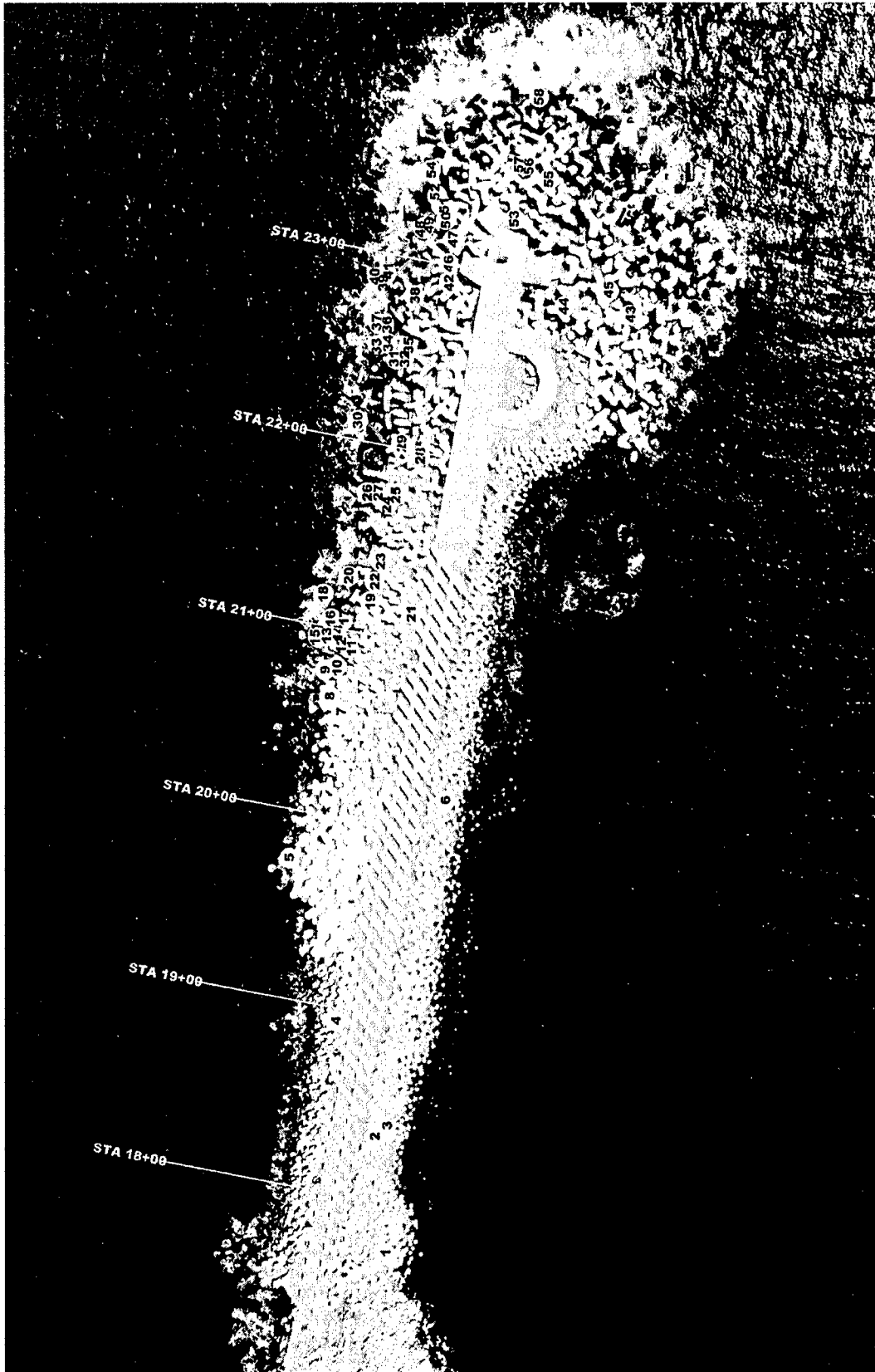

Figure 27. Approximate locations of broken/cracked armor units along outer portion of Kahului west breakwater



Figure 28. Dolos with mid-shank crack



Figure 29. Dolos with fluke-shank break

Kahului west breakwater, and none on the Laupahoehoe breakwater . A walking inspection of the Kahului breakwaters in September 1992, however, was conducted as part of an ongoing research study funded by another work unit. This inspection indicated a considerably larger number of broken armor units than obtained during the aerial surveillance. Eleven and 28 broken units were identified on the east and west breakwaters, respectively. The difference is



Figure 30. Dolos with shank-fluke break



Figure 31. Tribar with break through center section of unit

associated with the level of visibility between the two methods. The aerial inspection does not identify the cracked, but yet unbroken units; broken units in shadows; broken units in splash zones; and broken units in the underlayers.

A comparison of the number of broken armor units for the current (2001) survey on the Kahului breakwaters with those obtained during the walking

inspection of 1992 indicates significantly more broken units for the later survey (29 versus 11 and 58 versus 28 for the east and west breakwaters, respectively). Since no known major storm events occurred during this time period to cause the additional breakage, it is assumed that the 2001 survey was much more thorough than the 1992 survey. Therefore, the current broken armor unit survey will serve as a base condition for comparison of subsequent surveys. It was noted that concentrations of broken armor units on the Kahului breakwaters occurred in similar areas for both the 1992 and 2001 surveys.

As stated earlier, no broken or cracked armor units were found on the Laupahoehoe breakwater. It was noted, however, that some of the underlayer stone fill below the concrete rip cap was lost between stas 1+55 and 1+75. Also, armor stones on the harbor side of the structure between stas 0+85 and 0+95 have been displaced creating a small void. It appears that waves overtopping the structure are blowing these stones out and they are perched against the void.

### 3 Summary and Findings

---

The Kahului Harbor breakwaters have been repeatedly subjected to major storm events since completion of their construction in 1931. As a result, extensive breakwater damage has occurred. Major rehabilitations were completed in 1956, 1966, 1973, and 1984. The structures were originally armored with keyed-and-fitted stone, but now have several sizes of tetrapod, tribar, and dolos concrete armor units. The Kahului breakwaters are some of the most complex rubble-mound structures the Corps has constructed. The Laupahoehoe Point boat-launching facility breakwater was constructed in 1988 with 27,215-kg (30-ton) dolosse armor and appears to have been much more stable.

Sound, quantifiable data relative to the positions of the concrete armor units were initially obtained for the Kahului breakwaters during the period October 1991 - August 1993, and for the Laupahoehoe breakwater during the period October 1991 - November 1992, under the "Periodic Inspections" Work Unit of the Monitoring Completed Navigation Projects Program. Data from limited ground-based surveys, aerial photography, and photogrammetric analysis were obtained to establish precise base level conditions for the breakwaters. Accuracy of the photogrammetric analysis was validated and defined through comparison of ground and aerial survey data on control points and targets established on the structure. A method of high resolution, stereo aerial photographs, a stereoplotter, and MICROSTATION-based software was developed to analyze the entire above-water armor unit fields and quantify armor positions and subsequent movement. Minimal target movement occurred during the initial monitoring effort. Average movement of targets in both the horizontal and vertical directions was 0.046 m (0.15 ft) or less on the Kahului breakwaters, and less than 0.015 m (0.05 ft) on the Laupahoehoe structure.

Similar data were obtained during 2001 and compared with the 1992/1993 data obtained previously. An analysis of these data indicated some armor unit movements on the Kahului breakwaters (particularly the east breakwater) and negligible movement on the Laupahoehoe breakwater. On the Kahului east breakwater, one target moved about 0.9 m (3 ft) horizontally and one moved almost 1.5 m (5 ft) vertically. Both these units were located around the seaward head of the structure. The average movement of the targets, however, was on the order of about 0.15 m (0.5 ft). An evaluation of nontargeted units indicated several had changed horizontal positions (on the order of 0.3 to 0.9 m (1 to 3 ft)) also around the seaward quadrant of the head of the east breakwater. These units are intact, however, and continue to be functional. For the Kahului west

breakwater, comparisons of target coordinates showed relatively close agreement with those obtained in 1993. The average movement of all targets in both the horizontal and vertical directions was less than 0.015 m (0.5 ft). For the Laupahoehoe breakwater, average target movement in both the horizontal and vertical directions was less than 0.06 m (0.2 ft). Considering the movements of targeted armor units' centroids, average movements in both the horizontal and vertical directions were less than 0.18 m (0.6 ft) for the Kahului east breakwater, less than 0.12 m (0.4 ft) for the Kahului west breakwater, and around 0.03 m (0.1 ft) for the Laupahoehoe breakwater.

A total of 29 broken/cracked armor units on the Kahului east breakwater and 58 on the Kahului west breakwater were identified during the current (2001) survey. These data establish a base from which to evaluate future breakage in subsequent surveys. No broken/cracked armor units were found on the Laupahoehoe breakwater.

The Kahului and Laupahoehoe breakwaters will be revisited in the future under the "Periodic Inspections" Work Unit to gather data by which assessments can be made on the long-term response of the structures to their environment. The areas of concentrated breakage on the Kahului east and west breakwaters should be inspected annually to monitor any increase in breakage and thus reduction in stability. The insight gathered from these efforts will allow engineering decisions to be made, based on sound data, as to whether or not closer surveillance and/or repair of the structures might be required to reduce their chances of failing catastrophically. Also, the periodic inspection methods developed and validated for these breakwaters may be used to gain insight into other Corps structures.

# References

---

- Bottin, R. R., Jr., and Boc, S. J. (1996). "Periodic inspection of Nawiliwili Harbor breakwater, Kauai, Hawaii: Report 1, base conditions," Technical Report CERC-96-5, U.S. Army Engineer Waterways Experiment Station, Vicksburg, MS.
- Bottin, R. R., Jr., and Boc, S. J. (1997). "Periodic Inspection of Ofu Harbor breakwater, America Samoa: Report 1, base conditions," Technical Report CHL-97-32, U.S. Army Engineer Waterways Experiment Station, Vicksburg, MS.
- Bottin, R. R., Jr., Markle D. G., and Mize, M. G. (1987). "Design for navigation improvements, wave protection, and breakwater stability for proposed boat-launching facility, Laupahoehoe Point, Hawaii," Technical Report CERC-87-3, U.S. Army Engineer Waterways Experiment Station, Vicksburg, MS.
- Headquarters, U.S. Army Corps of Engineers. (1997). "Monitoring completed navigation projects; engineer and design," ER 1110-2-8151, Washington, DC.
- Jackson, R. A. (1964). "Designs for rubble-mound breakwater repair, Kahului Harbor, Maui, Hawaii," Technical Report No. 2-644, U.S. Army Engineer Waterways Experiment Station, Vicksburg, MS.
- Markle, D. G. (1982). Kahului breakwater, stability study, Kahului, Maui, Hawaii," Technical Report HL-82-14, U.S. Army Engineer Waterways Experiment Station, Vicksburg, MS.
- Markle, D. G., and Boc, S. J. (1994). "Periodic inspections of Kahului and Laupahoehoe breakwaters, Hawaii: Report 1, base conditions," Technical Report CERC-94-12, U.S. Army Engineer Waterways Experiment Station, Vicksburg, MS.
- Sargent, F., Markle, D., and Grace, P. (1988). "Case histories of Corps breakwater and jetty structures: Report 4, Pacific Ocean Division," Technical Report REMR-C0-3, U.S. Army Engineer Waterways Experiment Station, Vicksburg, MS.
- U.S. Army Engineer District, Honolulu. (1981). "Breakwater rehabilitation, Kahului Harbor, Maui, HI," General Design Memorandum, Ft. Shafter, HI.

U.S. Army Engineer District, Honolulu. (1984). "Laupahoehoe navigation improvements, Laupahoehoe, Hawaii," Final Detailed Project Report and Environmental Impact Statement, Ft. Shafter, HI.

**Table 1  
Description of Targeted Armor Units on Kahului and Laupahoehoe  
Breakwaters**

Location	Unit	Description	
Kahului East Breakwater	KEA	8,165-kg (9-ton) Tribar	
	KEB	8,165-kg (9-ton) Tribar	
	KEC	31,750-kg (35-ton) Tribar	
	KED	27,215-kg (30-ton) Dolos	
	KEE	27,215-kg (30-ton) Dolos	
	KEF	27,215-kg (30-ton) Dolos	
	KEG	31,750-kg (35-ton) Tribar	
	KEH	27,215-kg (30-ton) Dolos	
	KEI	27,215-kg (30-ton) Dolos	
	KEJ	5,445-kg (6-ton) Dolos	
	Kahului West Breakwater	KWA	9,980-kg (11-ton) Tribar
		KWB	31,750-kg (35-ton) Tribar
KWC		27,215-kg (30-ton) Dolos	
KWD		27,215-kg (30-ton) Dolos	
KWE		27,215-kg (30-ton) Dolos	
KWF		27,215-kg (30-ton) Dolos	
KWG		31,750-kg (35-ton) Tribar	
KWH		27,215-kg (30-ton) Dolos	
KWI		5,900-kg (6.5-ton) Tribar	
KWJ		5,900-kg (6.5-ton) Tribar	
Laupahoehoe Breakwater		LA	27,215-kg (30-ton) Dolos
	LB	27,215-kg (30-ton) Dolos	
	LC	27,215-kg (30-ton) Dolos	
	LD	27,215-kg (30-ton) Dolos	
	LE	27,215-kg (30-ton) Dolos	

**Table 2  
Comparison of 2001 and 1993 Aerial Survey Data Obtained for Armor Unit Targets on Kahului East Breakwater**

Target ID	2001 Aerial Survey			1993 Aerial Survey			Absolute Value of Differences Between 2001 and 1993 Aerial Surveys		
	Easting (E01)	Northing (N01)	Elevation (E101), m (ft)	Easting (E93)	Northing (N93)	Elevation (E193), m (ft)	E01-E93, cm (ft)	N01-N93, cm (ft)	E101-E193, cm (ft)
KEA1	566164.42	206888.54	+1.67 (+5.48)	566164.38	206888.41	+1.61 (+5.28)	1.22 (0.04)	3.96 (0.13)	6.10 (0.20)
KEA2	566169.30	206885.41	+1.70 (+5.58)	566169.26	206885.34	+1.63 (+5.34)	1.22 (0.04)	2.13 (0.07)	7.32 (0.24)
KEA3	566164.25	206882.77	+1.40 (+4.59)	566164.15	206882.66	+1.34 (+4.41)	3.05 (0.10)	3.35 (0.11)	5.49 (0.18)
KEB1	565756.22	207111.02	+1.96 (+6.42)	565756.76	207112.94	+1.97 (+6.45)	16.46 (0.54)	58.52 (1.92)	0.91 (0.03)
KEB2	565754.66	207106.09	+1.14 (+3.74)	565755.49	207107.54	+1.43 (+4.70)	25.30 (0.83)	44.20 (1.45)	29.26 (0.96)
KEB3	565750.89	207110.54	+1.26 (+4.15)	565751.33	207111.64	+1.47 (+4.82)	13.41 (0.44)	33.53 (1.10)	20.42 (0.67)
KEC1	565596.51	207201.75	+2.37 (+7.78)	565596.80	207201.62	+2.38 (+7.82)	8.84 (0.29)	3.96 (0.13)	1.22 (0.04)
KEC2	565591.78	207210.39	+3.17 (+10.39)	565592.19	207210.26	+3.25 (+10.66)	12.50 (0.41)	3.96 (0.13)	8.23 (0.27)
KEC3	565601.95	207209.66	+3.37 (+11.07)	565602.26	207209.47	+3.36 (+11.01)	9.45 (0.31)	5.79 (0.19)	1.83 (0.06)
KED1	565608.34	207274.05	+4.01 (+13.16)	565609.27	207271.74	+5.53 (+18.13)	28.35 (0.93)	70.41 (2.31)	151.49 (4.97)
KED2	565620.74	207273.28	+4.10 (+13.46)	565621.08	207272.81	+4.36 (+14.31)	10.36 (0.34)	14.33 (0.47)	25.91 (0.85)
KED3	565613.74	207262.91	+3.58 (+11.75)	565614.50	207262.25	+3.67 (+12.04)	23.16 (0.76)	20.12 (0.66)	8.84 (0.29)
KEE1	565669.50	207296.57	+4.23 (+13.89)	565669.87	207298.86	+4.22 (+13.84)	11.28 (0.37)	69.80 (2.29)	1.52 (0.05)
KEE2	565681.76	207294.80	+4.60 (+15.09)	565682.00	207297.86	+4.97 (16.32)	7.32 (0.24)	93.27 (3.06)	37.49 (1.23)
KEE3				565675.77	207287.77	+3.73 (+12.24)			
KEF1	565723.01	207265.81	+4.02 (+13.19)	565722.83	207265.55	+4.15 (+13.63)	5.49 (0.18)	7.92 (0.26)	13.41 (0.44)
KEF2	565732.58	207272.08	+2.43 (+7.98)	565732.38	207271.71	+2.58 (+8.46)	6.10 (0.20)	11.28 (0.37)	14.63 (0.48)
KEF3	565732.66	207259.22	+2.73 (+8.95)	565732.52	207259.09	+2.82 (+9.25)	4.27 (0.14)	3.96 (0.13)	9.14 (0.30)
KEG1	565750.05	207222.05	+2.89 (+9.48)	565749.82	207222.09	+2.96 (+9.71)	7.01 (0.23)	1.22 (0.04)	7.01 (0.23)
KEG2	565755.68	207228.84	+3.16 (+10.37)	565755.48	207228.80	+3.22 (+10.55)	6.10 (0.20)	1.22 (0.04)	5.49 (0.18)
KEG3	565758.80	207220.58	+2.78 (+9.12)	565758.51	207220.59	+2.82 (+9.25)	8.84 (0.29)	0.30 (0.01)	3.96 (0.13)

**Table 2 (Concluded)**

Target ID	2001 Aerial Survey			1993 Aerial Survey			Absolute Value of Differences Between 2001 and 1993 Aerial Surveys		
	Easting (E01)	Northing (N01)	Elevation (E101), m (ft)	Easting (E93)	Northing (N93)	Elevation (E193), m (ft)	E01-E93, cm (ft)	N01-N93, cm (ft)	E101-E193, cm (ft)
KEH1	565996.17	207058.29	+4.72 (+15.49)	565996.06	207058.36	+4.86 (+15.93)	3.35 (0.11)	2.13 (0.07)	13.41 (0.44)
KEH2	566006.22	207065.09	+5.52 (+18.12)	566006.22	207065.14	+5.46 (+17.90)	0.00 (0.00)	1.52 (0.05)	6.71 (0.22)
KEH3	566007.65	207052.97	+4.65 (+15.24)	566007.53	207053.06	+4.64 (+15.23)	3.66 (0.12)	2.74 (0.09)	0.30 (0.01)
KEI1	566180.75	206939.81	+3.64 (+11.94)	566180.15	206939.43	+3.51 (+11.51)	18.29 (0.60)	11.58 (0.38)	13.11 (0.43)
KEI2	566188.57	206944.49	+5.36 (+17.58)	566187.76	206945.04	+5.17 (+16.97)	24.69 (0.81)	16.76 (0.55)	18.59 (0.61)
KEI3	566188.95	206933.70	+4.78 (+15.69)	566189.19	206934.43	+4.66 (+15.30)	7.32 (0.24)	22.25 (0.73)	11.89 (0.39)
KEJ1	566270.11	206882.16	+2.69 (+8.83)	566270.83	206882.86	+2.86 (+9.37)	21.95 (0.72)	21.34 (0.70)	16.46 (0.54)
KEJ2				566276.13	206887.23	+2.41 (+7.91)			
KEJ3	566276.73	206882.91	+3.65 (+11.99)	566277.32	206881.72	+3.83 (+12.56)	17.98 (0.59)	36.27 (1.19)	17.37 (0.57)

(Sheet 2 of 2)

**Table 3**

**Comparison of 2001 and 1993 Aerial Survey Data Obtained for Armor Unit Targets on Kahului West Breakwater**

Target ID	2001 Aerial Survey				1993 Aerial Survey				Absolute Value of Differences Between 2001 and 1993 Aerial Surveys			
	Easting (E01)	Northing (N01)	Elevation (E101), m (ft)	Easting (E93)	Northing (N93)	Elevation (E193), m (ft)	E01-E93, cm (ft)	N01-N93, cm (ft)	E101-E193, cm (ft)			
	KWA1	564375.25	206990.93	+2.54 (+8.33)	564374.97	206990.72	+2.59 (+8.51)	8.53 (0.28)	6.40 (0.21)	5.49 (0.18)		
KWA2	564378.32	206987.20	+3.68 (+12.08)	564378.20	206986.89	+3.71 (+12.16)	3.66 (0.12)	9.45 (0.31)	2.44 (0.08)			
KWA3	564373.13	206985.60	+3.25 (+10.67)	564372.42	206985.46	+3.18 (+10.43)	21.64 (0.71)	4.27 (0.14)	7.32 (0.24)			
KWB1	564486.29	207060.01	+2.35 (+7.70)	564486.33	207060.14	+2.39 (+7.84)	1.22 (0.04)	3.96 (0.13)	4.27 (0.14)			
KWB2	564491.65	207064.83	+2.79 (+9.16)	564491.58	207064.87	+2.86 (+9.38)	2.13 (0.07)	1.22 (0.04)	6.71 (0.22)			
KWB3	564493.35	207057.97	+2.19 (+7.17)	564493.30	207058.06	+2.26 (+7.43)	1.52 (0.05)	2.74 (0.09)	7.92 (0.26)			
KWC1	564614.41	207111.49	+3.20 (+10.49)	564614.52	207111.51	+3.30 (+10.84)	3.35 (0.11)	0.61 (0.02)	10.67 (0.35)			
KWC2	564607.79	207105.18	+5.04 (+16.52)	564607.90	207105.11	+5.08 (+16.67)	3.35 (0.11)	2.13 (0.07)	4.57 (0.15)			
KWC3	564603.75	207114.02	+3.54 (+11.63)	564603.96	207114.05	+3.71 (12.16)	6.40 (0.21)	0.91 (0.03)	16.15 (0.53)			
KWD1	564698.37	207141.38	+3.54 (+11.60)	564698.17	207141.53	+3.58 (+11.74)	6.10 (0.20)	4.57 (0.15)	4.27 (0.14)			
KWD2	564694.17	207153.33	+3.84 (+12.61)	564694.02	207153.42	+3.90 (+12.78)	4.57 (0.15)	2.74 (0.09)	5.18 (0.17)			
KWD3	564687.27	207143.88	+5.12 (+16.80)	564687.20	207144.06	+5.17 (+16.95)	2.13 (0.07)	5.49 (0.18)	4.57 (0.15)			
KWE1	564786.75	207172.45	+4.25 (+13.94)	564787.80	207173.35	+4.28 (+14.04)	32.00 (1.05)	27.43 (0.90)	3.05 (0.10)			
KWE2	564789.34	207184.49	+3.72 (+12.20)	564788.82	207185.43	+3.57 (+11.70)	15.85 (0.52)	28.65 (0.94)	15.24 (0.50)			
KWE3	564777.54	207180.59	+3.42 (+11.23)	564777.48	207179.97	+3.69 (+12.10)	1.83 (0.06)	18.90 (0.62)	26.52 (0.87)			
KWF1	564804.20	207148.16	+4.04 (+13.26)	564803.79	207148.67	+4.01 (+13.17)	12.50 (0.41)	15.54 (0.51)	2.74 (0.09)			
KWF2	564816.30	207149.37	+3.02 (+9.90)	564815.93	207150.07	+3.07 (+10.07)	11.28 (0.37)	21.34 (0.70)	5.18 (0.17)			
KWF3	564810.86	207157.86	+5.28 (+17.33)	564810.39	207158.10	+5.44 (+17.84)	14.33 (0.47)	7.32 (0.24)	15.54 (0.51)			
KWG1	564796.14	207100.21	+3.33 (+10.92)	564795.64	207100.53	+3.40 (+11.17)	15.24 (0.50)	9.75 (0.32)	7.62 (0.25)			
KWG2	564805.84	207098.03	+2.77 (+9.10)	564805.24	207098.32	+2.84 (+9.31)	18.29 (0.60)	8.84 (0.29)	6.40 (0.21)			
KWG3	564802.94	207107.64	+3.23 (+10.60)	564802.41	207107.89	+3.27 (+10.74)	16.15 (0.53)	7.62 (0.25)	4.27 (0.14)			

**Table 3 (Concluded)**

Target ID	2001 Aerial Survey			1993 Aerial Survey			Absolute Value of Differences Between 2001 and 1993 Aerial Surveys		
	Easting (E01)	Northing (N01)	Elevation (EI01), m (ft)	Easting (E93)	Northing (N93)	Elevation (EI93), m (ft)	E01-E93, cm (ft)	N01-N93, cm (ft)	EI01-EI93, cm (ft)
KWH1	564753.05	207041.65	+3.51 (+11.52)	564753.72	207044.76	+2.95 (+9.69)	20.42 (0.67)	3.35 (0.11)	55.78 (1.83)
KWH2	564743.16	207034.90	+2.21 (+7.26)	564744.62	207035.91	+2.80 (+9.17)	44.50 (1.46)	30.78 (1.01)	58.22 (1.91)
KWH3	564753.12	207029.25	+3.66 (+12.02)	564756.05	207033.05	+3.96 (+12.98)	89.31 (2.93)	115.82 (3.80)	29.26 (0.96)
KWI1	564592.61	207032.58	+2.42 (+7.93)	564592.49	207032.86	+2.45 (+8.05)	3.66 (0.12)	8.53 (0.28)	3.66 (0.12)
KWI2	564597.43	207031.08	+1.98 (+6.48)	564597.32	207031.31	+2.05 (+6.73)	3.35 (0.11)	7.01 (0.23)	7.62 (0.25)
KWI3	564593.24	207027.83	+1.82 (+5.97)	564593.24	207028.03	+1.85 (+6.06)	0.00 (0.00)	6.10 (0.20)	2.74 (0.09)
KWJ1	564472.09	206971.63	+1.43 (+4.70)	564471.91	206971.46	+1.45 (+4.76)	5.49 (0.18)	5.18 (0.17)	1.83 (0.06)
KWJ2	564469.07	206967.42	+1.34 (+4.38)	564468.89	206967.24	+1.36 (+4.46)	5.49 (0.18)	5.49 (0.18)	2.44 (0.08)
KWJ3	564467.00	206972.16	+1.43 (+4.69)	564466.73	206972.00	+1.48 (+4.84)	8.23 (0.27)	4.88 (0.16)	4.57 (0.15)

**Table 4**

**Comparison of 2001 and 1992 Aerial Survey Data Obtained for Armor Unit Targets on Laupahoehoe Breakwater**

Target ID	2001 Aerial Survey			1992 Aerial Survey			Absolute Value of Differences Between 2001 and 1992 Aerial Surveys		
	Easting (E01)	Northing (N01)	Elevation (E101), m (ft)	Easting (E92)	Northing (N92)	Elevation (E192), m (ft)	E01-E92, cm (ft)	N01-N92, cm (ft)	E101-E192, cm (ft)
LA1	588382.69	421935.37	+3.62 (+11.87)	588382.68	421935.34	+3.64 (+11.94)	0.30 (0.01)	0.91 (0.03)	2.13 (0.07)
LA2	588392.93	421929.06	+4.65 (+15.26)	588392.89	421929.03	+4.68 (+15.35)	1.22 (0.04)	0.91 (0.03)	2.74 (0.09)
LA3	588383.18	421922.72	+3.20 (+10.50)	588383.29	421922.77	+3.20 (+10.51)	3.35 (0.11)	1.52 (0.05)	0.30 (0.01)
LB1	588392.41	421884.06	+3.14 (+10.31)	588392.30	421884.27	+3.27 (+10.74)	3.35 (0.11)	6.40 (0.21)	13.11 (0.43)
LB2	588398.26	421874.44	+4.76 (+15.61)	588398.31	421874.78	+4.85 (+15.91)	1.52 (0.05)	10.36 (0.34)	9.14 (0.30)
LB3	588387.15	421872.49	+3.18 (+10.44)	588387.44	421872.70	+3.20 (+10.50)	8.84 (0.29)	6.40 (0.21)	1.83 (0.06)
LC1	588389.69	421862.56	+1.62 (+5.33)	588389.73	421862.53	1.69 (+5.55)	1.22 (0.04)	0.91 (0.03)	6.71 (0.22)
LC2	588399.39	421858.22	+3.61 (+11.84)	588399.46	421858.29	+3.62 (+11.89)	2.13 (0.07)	2.13 (0.07)	1.52 (0.05)
LC3	588390.98	421850.04	+2.36 (+7.74)	588391.03	421850.21	+2.41 (+7.90)	1.52 (0.05)	5.18 (0.17)	4.88 (0.16)
LD1	588354.57	421851.96	+1.65 (+5.42)	588354.75	421851.86	+1.71 (+5.60)	5.49 (0.18)	3.05 (0.10)	5.49 (0.18)
LD2	588361.82	421845.16	+3.96 (+12.99)	588361.93	421844.95	+3.98 (+13.06)	3.35 (0.11)	6.40 (0.21)	2.13 (0.07)
LD3	588350.98	421840.30	+2.76 (+9.05)	588351.06	421840.29	+2.77 (+9.09)	2.44 (0.08)	0.30 (0.01)	1.22 (0.04)
LE1	588362.36	421894.26	+2.50 (+8.21)	588362.41	421894.20	+2.50 (+8.21)	1.52 (0.05)	1.83 (0.06)	0.00 (0.00)
LE2	588362.22	421881.60	+2.67 (+8.77)	588362.25	421881.54	+2.66 (+8.73)	0.91 (0.03)	1.83 (0.06)	1.22 (0.04)
LE3	588352.18	421888.19	+3.70 (+12.15)	588352.26	421888.10	+3.72 (+12.20)	2.44 (0.08)	2.74 (0.09)	1.52 (0.05)

**Table 5  
Comparison of Centroid Data for Targeted Armor Units for 2001 and 1993 Aerial Survey Data for Kahului East Breakwater**

Armor Unit ID	2001 Aerial Survey			1993 Aerial Survey			Absolute Value of Differences Between 2001 and 1993 Aerial Surveys		
	Easting (E01)	Northing (N01)	Elevation (E101), m (ft)	Easting (E93)	Northing (N93)	Elevation (E193), m (ft)	E01-E93, cm (ft)	N01-N93, cm (ft)	E101-E193, cm (ft)
KEA	566166.30	206885.98	0.78 (2.56)	566166.21	206885.86	0.71 (2.34)	2.74 (0.09)	3.66 (0.12)	6.71 (0.22)
KEB	565754.80	207110.15	0.73 (2.38)	565755.12	207111.37	0.84 (2.76)	9.75 (0.32)	37.19 (1.22)	11.58 (0.38)
KEC	565597.12	207208.81	1.64 (5.38)	565597.33	207208.70	1.67 (5.47)	3.66 (0.12)	3.35 (0.11)	2.74 (0.09)
KED	565614.58	207270.38	2.84 (9.31)	565614.07	207270.16	3.51 (11.51)	6.10 (0.20)	6.71 (0.22)	67.06 (2.20)
KEE	565675.76	207293.83	2.98 (9.79)	565676.39	207295.59	3.29 (10.79)	19.20 (0.63)	53.64 (1.76)	30.48 (1.00)
KEF	565728.13	207265.44	2.07 (6.79)	565727.94	207265.23	2.19 (7.20)	5.79 (0.19)	6.40 (0.21)	12.50 (0.41)
KEG	565754.78	207224.41	1.71 (5.60)	565754.50	207224.42	1.76 (5.78)	8.53 (0.28)	0.30 (0.01)	5.49 (0.18)
KEH	566003.54	207059.38	3.91 (12.84)	566003.31	207059.37	3.23 (12.89)	7.01 (0.23)	0.30 (0.01)	1.52 (0.05)
KEI	566187.53	206939.66	3.77 (12.38)	566187.07	206940.03	3.62 (11.87)	14.02 (0.46)	11.28 (0.37)	15.54 (0.51)
KEJ	566275.09	206883.48	2.21 (7.24)	566275.38	206882.55	2.41 (7.91)	8.84 (0.29)	28.35 (0.93)	20.42 (0.67)

**Table 6**

**Comparison of Centroid Data for Targeted Armor Units for 2000 and 1993 Aerial Survey Data for Kahului West Breakwater**

Armor Unit ID	2000 Aerial Survey			1993 Aerial Survey			Absolute Value of Differences Between 2000 and 1993 Aerial Surveys		
	Easting (E00)	Northing (N00)	Elevation (EI00), m (ft)	Easting (E93)	Northing (N93)	Elevation (EI93), m (ft)	E00-E93, cm (ft)	N00-N93, cm (ft)	EI00-EI93, cm (ft)
KWA	564376.70	206986.50	2.47 (8.09)	564376.20	206986.40	2.45 (8.04)	15.24 (0.50)	3.05 (0.10)	1.52 (0.05)
KWB	564490.40	207061.70	1.41 (4.64)	564490.50	207061.80	1.48 (4.85)	3.05 (0.10)	3.05 (0.10)	6.40 (0.21)
KWC	564608.00	207108.80	3.12 (10.25)	564608.10	207108.90	3.22 (10.55)	3.05 (0.10)	3.05 (0.10)	9.14 (0.30)
KWD	564692.00	207146.00	3.18 (10.42)	564691.80	207146.20	3.22 (10.58)	6.10 (0.20)	6.10 (0.20)	4.88 (0.16)
KWE	564784.90	207178.80	2.74 (8.99)	564784.80	207179.20	2.79 (9.14)	3.05 (0.10)	12.19 (0.40)	4.57 (0.15)
KWF	564809.50	207153.40	3.21 (10.54)	564809.10	207154.00	3.29 (10.81)	12.19 (0.40)	18.29 (0.60)	8.23 (0.27)
KWG	564800.90	207102.50	1.72 (5.64)	564800.30	207102.70	1.78 (5.85)	18.29 (0.60)	6.10 (0.20)	18.59 (0.61)
KWH	564751.10	207035.30	2.14 (7.03)	564752.20	207037.40	2.20 (7.23)	33.53 (1.10)	64.01 (2.10)	6.10 (0.20)
KWI	564594.00	207031.40	1.39 (4.57)	564594.00	207031.60	1.44 (4.72)	0.00 (0.00)	6.10 (0.20)	4.57 (0.15)
KWJ	564469.40	206970.60	0.67 (2.19)	564469.20	206970.40	0.67 (2.19)	6.10 (0.20)	6.10 (0.20)	0.00 (0.00)

**Table 7**

**Comparison of Centroid Data for Targeted Armor Units for 2001 and 1992 Aerial Survey Data for Laupahoehoe Breakwater**

Armor Unit ID	2001 Aerial Survey			1992 Aerial Survey			Absolute Value of Differences Between 2001 and 1992 Aerial Surveys		
	Easting (E01)	Northing (N01)	Elevation (E101), m (ft)	Easting (E92)	Northing (N92)	Elevation (E192), m (ft)	E01-E92, cm (ft)	N01-N92, cm (ft)	E101-E192, cm (ft)
LA	588387.30	421929.50	2.81 (9.23)	588387.40	421929.50	2.83 (9.29)	3.05 (0.10)	0.00 (0.00)	1.83 (0.06)
LB	588393.90	421876.40	2.72 (8.94)	588394.10	421876.70	2.81 (9.22)	6.10 (0.20)	9.14 (0.30)	8.53 (0.28)
LC	588394.90	421856.50	1.59 (5.21)	588394.90	421856.60	1.62 (5.33)	0.00 (0.00)	3.05 (0.10)	3.66 (0.12)
LD	588357.20	421844.50	1.90 (6.23)	588357.30	421844.40	1.92 (6.30)	3.05 (0.10)	3.05 (0.10)	2.13 (0.07)
LE	588358.00	421887.90	1.93 (6.33)	588358.00	421887.80	1.93 (6.34)	0.00 (0.00)	3.05 (0.10)	0.30 (0.01)

**Table 8**

**Comparison of Rotation Angles for Targeted Armor Units for 2001 and 1993 Aerial Survey Data for Kahului East Breakwater**

Armor Unit ID	2001 Rotation Angle (deg)			1993 Rotation Angle (deg)			Difference Between 2001 and 1993 Rotation Angles (deg)		
	x-axis	y-axis	z-axis	x-axis	y-axis	z-axis	x-axis	y-axis	z-axis
KEA	10.75	-0.99	-31.83	10.22	-0.60	-32.35	0.53	-0.39	0.52
KEB	16.42	-23.19	13.26	10.25	-16.30	16.92	6.17	-6.89	-3.66
KEC	19.56	-3.82	-2.46	20.05	-1.99	-2.95	-0.49	-1.83	0.49
KED	27.23	7.80	-128.30	2.66	10.34	-122.33	24.57	-2.54	-5.97
KEE	10.93	-18.93	120.15	12.68	-7.26	120.24	-1.75	-11.67	-0.09
KEF	4.52	-4.31	-88.66	4.33	-3.58	-88.89	0.19	-0.73	0.23
KEG	5.96	-5.76	50.66	6.57	-5.47	50.36	-0.61	-0.29	0.30
KEH	15.94	-1.13	156.04	18.16	-3.17	156.59	-2.22	2.04	-0.55
KEI	4.74	20.14	142.71	6.18	20.17	148.07	-1.44	-0.03	-5.36
KEJ	-15.81	13.02	50.82	-13.49	12.02	42.89	-2.32	1.00	7.93

**Table 9**

**Comparison of Rotation Angles for Targeted Armor Units for 2000 and 1993 Aerial Survey Data for Kahului West Breakwater**

Armor Unit ID	2000 Rotation Angle (deg)			1993 Rotation Angle (deg)			Difference Between 2000 and 1993 Rotation Angles (deg)		
	x-axis	y-axis	z-axis	x-axis	y-axis	z-axis	x-axis	y-axis	z-axis
KWA	-4.17	-37.89	-46.53	-0.82	-36.08	-51.23	-3.35	-1.81	4.7
KWB	9.94	-9.09	44.32	9.27	-9.94	44.11	0.67	0.85	0.21
KWC	-4.65	5.94	-13.26	-2.89	6.93	-13.93	-1.76	-0.99	0.67
KWD	4.73	4.56	-71.40	4.46	4.72	-71.60	0.27	-0.16	0.2
KWE	18.81	-4.47	20.53	19.18	1.82	25.38	-0.37	-6.29	-4.85
KWF	-2.59	-15.45	-174.66	-5.56	-14.24	-174.60	2.97	-1.21	-0.06
KWG	10.89	1.82	46.90	10.87	2.46	46.54	0.02	-0.64	0.36
KWH	13.70	-19.67	39.74	11.25	-2.35	44.68	2.45	-17.32	-4.94
KWI	5.41	-22.28	100.99	3.79	-22.17	100.99	1.62	-0.11	0.00
KWJ	4.00	-0.11	-6.06	4.31	0.88	-5.47	-0.31	-0.99	-0.59

Table 10 Comparison of Rotation Angles for Targeted Armor Units for 2001 and 1992 Aerial Survey Data for Laupahoehoe Breakwater												
Armor Unit ID	2001 Rotation Angle (deg)			1992 Rotation Angle (deg)			Difference Between 2001 and 1992 Rotation Angles (deg)					
	x-axis	y-axis	z-axis	x-axis	y-axis	z-axis	x-axis	y-axis	z-axis			
LA	8.36	-6.18	93.44	7.91	-6.48	93.54	-0.04	-0.02	-0.06			
LB	1.41	0.55	65.38	0.93	-1.1	57.03	-0.15	-0.36	-0.28			
LC	0.34	10.81	95.62	1.08	10.74	95.63	-0.01	-0.06	-0.12			
LD	-2.9	16.61	73.84	-2.63	16.04	73.18	-0.1	0.09	-0.07			
LE	10.86	-2.55	-90.08	10.44	-2.35	-90.05	-0.03	0.06	-0.01			

**Table 11****Broken Armor Unit Inventory Data**

Armor Unit No.	Station No.	Type of Armor Unit	Offset from Center line, m (ft)		Type of Break, Comments
			Sea Side	Harbor Side	
<b>East Breakwater</b>					
1	19+60	5,445-kg (6-ton) Dolos	8.23 (27)		End of fluke broken off (straight)
2	19+80	5,445-kg (6-ton) Dolos	4.27 (14)		Straight fluke-shank break
3	19+82	5,445-kg (6-ton) Dolos	10.67 (35)		Straight shank-fluke break
4	19+84	5,445-kg (6-ton) Dolos	10.67 (35)		Straight shank-fluke break
5	20+01	5,445-kg (6-ton) Dolos	4.27 (14)		Straight shank-fluke break
6	20+15	5,445-kg (6-ton) Dolos	4.57 (15)		Mid-shank crack
7	20+16	5,445-kg (6-ton) Dolos	6.71 (22)		Two straight fluke-shank breaks
8	20+20	5,445-kg (6-ton) Dolos	8.84 (29)		Straight shank-fluke break
9	20+22	5,445-kg (6-ton) Dolos	9.45 (31)		Straight shank-fluke break
10	20+24	5,445-kg (6-ton) Dolos	8.23 (27)		Straight fluke-shank and straight shank-fluke breaks
11	20+25	5,445-kg (6-ton) Dolos	8.84 (29)		Two straight shank-fluke breaks
12	20+35	5,445-kg (6-ton) Dolos	4.27 (14)		Straight shank-fluke break
13	20+39	5,445-kg (6-ton) Dolos	4.89 (16)		Straight shank-fluke break
14	20+48	5,445-kg (6-ton) Dolos	9.45 (31)		Angled shank-fluke break
15	20+50	5,445-kg (6-ton) Dolos	10.97 (36)		Straight shank-fluke break
16	20+75	5,445-kg (6-ton) Dolos	8.23 (27)		Straight fluke-shank break
17	20+79	5,445-kg (6-ton) Dolos	7.62 (25)		Straight shank-fluke break
18	20+80	5,445-kg (6-ton) Dolos	7.92 (26)		Straight shank-fluke break
19	20+84	5,445-kg (6-ton) Dolos	9.14 (30)		Straight shank-fluke break
20	23+32	8,165-kg (9-ton) Tribar		7.32 (24)	Broken through center of unit
21	25+47	31,750-kg (35-ton) Tribar	14.94 (49)		Leg broken off unit
22	26+31	8,165-kg (9-ton) Tribar		7.01 (23)	Angled crack through center of unit
23	26+59	31,750-kg (35-ton) Tribar	16.46 (54)		Leg broken off unit
24	26+87	27,215-kg (30-ton) Dolos	23.16 (76)		Angled shank-fluke break
25	27+35	31,750-kg (35-ton) Tribar	5.18 (17)		Crack through leg and center of unit
26	27+71	31,750-kg (35-ton) Tribar		23.47 (77)	Leg broken off unit
27	27+84	27,215-kg (30-ton) Dolos	16.76 (55)		Straight shank-fluke crack
28	28+03	27,215-kg (30-ton) Dolos	4.57 (15)		Straight shank-fluke break
29	28+11	27,215-kg (30-ton) Dolos	7.32 (24)		Straight fluke-shank break

**Table 11 (Continued)**

Armor Unit No.	Station No.	Type of Armor Unit	Offset from Center line, m (ft)		Type of Break, Comments
			Sea Side	Harbor Side	
<b>West Breakwater</b>					
1	17+73	5,900-kg (6.5-ton) Tribar		11.28 (37)	Leg broken off unit
2	18+37	5,900-kg (6.5-ton) Tribar		4.89 (16)	Broken through center of unit
3	18+46	5,900-kg (6.5-ton) Tribar		7.62 (25)	Broken through center of unit
4	18+89	9,980-kg (11-ton) Tribar	3.96 (13)		Broken through center of unit
5	19+53	17,235-kg (19-ton) Tribar	13.72 (45)		Crack through center of unit
6	20+27	5,900-kg (6.5-ton) Tribar		7.32 (24)	Hairline crack through center of unit
7	20+53	17,235-kg (19-ton) Tribar	14.02 (46)		Broken through center of unit, one leg missing
8	20+55	17,235-kg (19-ton) Tribar	16.76 (55)		Leg broken off unit
9	20+67	17,235-kg (19-ton) Tribar	18.29 (60)		Leg broken off unit
10	20+68	17,235-kg (19-ton) Tribar	17.68 (58)		One half leg broken off unit
11	20+85	17,235-kg (19-ton) Tribar	16.76 (55)		One half leg broken off unit
12	20+85	17,235-kg (19-ton) Tribar	17.68 (58)		Leg broken off unit
13	20+89	17,235-kg (19-ton) Tribar	18.29 (60)		Leg broken off unit
14	20+89	17,235-kg (19-ton) Tribar	16.76 (55)		Leg broken off unit
15	20+89	18,145-kg (20-ton) Dolos	19.20 (63)		Straight shank-fluke break
16	20+96	18,145-kg (20-ton) Dolos	20.73 (68)		Angled shank-fluke break
17	20+96	18,145-kg (20-ton) Dolos	19.81 (65)		Angled shank-fluke break
18	21+05	18,145-kg (20-ton) Dolos	20.73 (68)		Straight shank-fluke break
19	21+14	17,235-kg (19-ton) Tribar	12.19 (40)		Broken up in pieces
20	21+19	18,145-kg (20-ton) Dolos	16.76 (55)		Angled shank-fluke break
21	21+21	17,235-kg (19-ton) Tribar	4.57 (15)		Broken through center of unit
22	21+24	17,235-kg (19-ton) Tribar	12.19 (40)		Leg broken off unit
23	21+34	17,235-kg (19-ton) Tribar	12.19 (40)		Leg broken off unit
24	21+69	17,235-kg (19-ton) Tribar	11.58 (38)		Broken through center of unit
25	21+74	17,235-kg (19-ton) Tribar	10.67 (35)		Broken through center of unit
26	21+74	18,145-kg (20-ton) Dolos	17.68 (58)		Angled shank-fluke break
27	21+74	29,940-kg (33-ton) Tetrapod	15.24 (50)		Leg broken off unit
28	21+96	17,235-kg (19-ton) Tribar	7.62 (25)		Crack through leg
29	22+04	18,145-kg (20-ton) Dolos	11.28 (37)		Straight shank-fluke crack
30	22+10	18,145-kg (20-ton) Dolos	18.90 (62)		Straight shank-fluke break
31	22+43	29,940-kg (33-ton) Tetrapod	14.63 (48)		Leg broken off unit
32	22+44	18,145-kg (20-ton) Dolos	13.41 (44)		Straight shank-fluke break
33	22+49	18,145-kg (20-ton) Dolos	17.98 (59)		Straight shank-fluke break

**Table 11 (Concluded)**

Armor Unit No.	Station No.	Type of Armor Unit	Offset from Center line, m (ft)		Type of Break, Comments
			Sea Side	Harbor Side	
34	22+50	18,145-kg (20-ton) Dolos	16.46 (54)		Straight shank-fluke break
35	22+50	18,145-kg (20-ton) Dolos	10.97 (36)		Straight shank-fluke break
36	22+60	29,940-kg (33-ton) Tetrapod	17.68 (58)		Leg broken off unit
37	22+60	18,145-kg (20-ton) Dolos	18.29 (60)		Straight shank-fluke break
38	22+79	18,145-kg (20-ton) Dolos	13.72 (45)		Angled mid-shank break
39	22+82	18,145-kg (20-ton) Dolos	19.81 (65)		Angled shank-fluke break
40	22+83	18,145-kg (20-ton) Dolos	21.34 (70)		Straight shank-fluke break
41	22+84	18,145-kg (20-ton) Dolos	15.85 (52)		Straight shank-fluke break
42	22+89	18,145-kg (20-ton) Dolos	8.53 (28)		Angled mid-shank break
43	22+89	31,750-kg (35-ton) Tribar		21.34 (70)	Part of leg broken off unit
44	22+89	31,750-kg (35-ton) Tribar		10.67 (35)	Crack across leg of unit
45	22+99	31,750-kg (35-ton) Tribar		17.37 (57)	Part of leg broken off unit
46	22+99	29,940-kg (33-ton) Tetrapod	9.14 (30)		Leg broken off unit
47	23+11	27,215-kg (30-ton) Dolos	9.14 (30)		Angled shank-fluke break
48	23+15	27,215-kg (30-ton) Dolos	14.33 (47)		Straight shank-fluke break
49	23+15	27,215-kg (30-ton) Dolos	14.33 (47)		Straight shank-fluke break
50	23+21	27,215-kg (30-ton) Dolos	10.97 (36)		Straight fluke-shank crack
51	23+28	27,215-kg (30-ton) Dolos	12.19 (40)		Straight mid-shank break
52	23+33	27,215-kg (30-ton) Dolos	13.11 (43)		Straight fluke-shank break
53	23+33	29,940-kg (33-ton) Tetrapod	0.91 (3)		Leg broken off unit
54	23+46	27,215-kg (30-ton) Dolos	14.94 (49)		Straight shank-fluke break
55	23+53	27,215-kg (30-ton) Dolos		4.27 (14)	Angled fluke-shank break
56	23+57	27,215-kg (30-ton) Dolos	0.30 (1)		Straight shank-fluke crack
57	23+57	27,215-kg (30-ton) Dolos	1.83 (6)		Straight shank-fluke break
58	23+94	27,215-kg (30-ton) Dolos		1.52 (5)	Straight mid-shank break

# REPORT DOCUMENTATION PAGE

Form Approved  
OMB No. 0704-0188

Public reporting burden for this collection of information is estimated to average 1 hour per response, including the time for reviewing instructions, searching existing data sources, gathering and maintaining the data needed, and completing and reviewing this collection of information. Send comments regarding this burden estimate or any other aspect of this collection of information, including suggestions for reducing this burden to Department of Defense, Washington Headquarters Services, Directorate for Information Operations and Reports (0704-0188), 1215 Jefferson Davis Highway, Suite 1204, Arlington, VA 22202-4302. Respondents should be aware that notwithstanding any other provision of law, no person shall be subject to any penalty for failing to comply with a collection of information if it does not display a currently valid OMB control number. **PLEASE DO NOT RETURN YOUR FORM TO THE ABOVE ADDRESS.**

<b>1. REPORT DATE (DD-MM-YYYY)</b> August 2002		<b>2. REPORT TYPE</b> Final report		<b>3. DATES COVERED (From - To)</b>	
<b>4. TITLE AND SUBTITLE</b>  Periodic Inspections of Kahului and Laupahoehoe Breakwaters, Hawaii; Armor Unit Monitoring for Period 1992/93-2001				<b>5a. CONTRACT NUMBER</b>	
				<b>5b. GRANT NUMBER</b>	
				<b>5c. PROGRAM ELEMENT NUMBER</b>	
<b>6. AUTHOR(S)</b> Robert R. Bottin, Jr., Daniel T. Meyers				<b>5d. PROJECT NUMBER</b>	
				<b>5e. TASK NUMBER</b>	
				<b>5f. WORK UNIT NUMBER</b>	
<b>7. PERFORMING ORGANIZATION NAME(S) AND ADDRESS(ES) AND ADDRESS(ES)</b>  U.S. Army Engineer Research and Development Center Environmental Laboratory 3909 Halls Ferry Road Vicksburg, MS 39180-6199;  U.S. Army Engineer District, Honolulu Building 230 Fort Shafter, HI 96858-5440				<b>8. PERFORMING ORGANIZATION REPORT NUMBER</b>  ERDC/CHL TR-02-11	
<b>9. SPONSORING / MONITORING AGENCY NAME(S) AND ADDRESS(ES)</b> U.S. Army Corps of Engineers Washington, DC 20314-1000				<b>10. SPONSOR/MONITOR'S ACRONYM(S)</b>	
				<b>11. SPONSOR/MONITOR'S REPORT NUMBER(S)</b>	
<b>12. DISTRIBUTION / AVAILABILITY STATEMENT</b> Approved for public release, distribution is unlimited.					
<b>13. SUPPLEMENTARY NOTES</b>					
<b>14. ABSTRACT</b> Selected coastal navigation structures are periodically monitored under the "Periodic Inspections" Work Unit of the Monitoring Completed Navigation Projects Program. Such monitoring is done to gain an understanding of the long-term structural response of unique structures to their environment. Periodic data sets are used to improve knowledge in design, construction, and maintenance of both existing and proposed coastal navigation projects. The Kahului Harbor breakwaters and the Laupahoehoe boat-launching facility breakwater, HI, were nominated for periodic monitoring by the U.S. Army Engineer District, Honolulu. The positions of the above-water, concrete armor units (tetrapods, tribars, and/or dolosse) on the breakwaters were initially obtained during the period 1991-1993 through limited ground surveys, aerial photography, and photogrammetric analysis. The structures were revisited in 2001 to determine changes that had occurred. Results indicated that some armor units had moved along the seaward quadrant of the head of the Kahului east breakwater. These units were intact, however, and are still functional. Armor unit movements on the Kahului west breakwater and the Laupahoehoe breakwater were minimal. A detailed inventory of broken armor units on these structures was obtained. The sites will be revisited in the future and the long-term structural response of the structures to their environment will continue to be tracked. These data sets will facilitate engineering decisions concerning whether or not closer surveillance and/or repair of the breakwaters might be required to reduce their chances of failing catastrophically. The periodic inspection methods developed and validated for the Hawaii breakwaters may also be used to gain insight into other Corps structures.					
<b>15. SUBJECT TERMS</b> Aerial photography      Dolosse      Rubble-mound      Photogrammetry      Kahului Harbor, Maui, HI Breakwaters      Periodic inspections      Tribons      Remote sensing Concrete armor units      Armor stability      Tetrapods      Laupahoehoe-boat-launching facility, HI					
<b>16. SECURITY CLASSIFICATION OF:</b>			<b>17. LIMITATION OF ABSTRACT</b>	<b>18. NUMBER OF PAGES</b>  63	<b>19a. NAME OF RESPONSIBLE PERSON</b>
<b>a. REPORT</b> UNCLASSIFIED	<b>b. ABSTRACT</b> UNCLASSIFIED	<b>c. THIS PAGE</b> UNCLASSIFIED			<b>19b. TELEPHONE NUMBER (include area code)</b>