

**US Army Corps  
of Engineers®**  
Engineer Research and  
Development Center

ERDC/CHL TR-02-13

Coastal and Hydraulics Laboratory

## **Navigation Conditions in Lower Lock Approach of Ice Harbor Lock and Dam, Snake River, Washington**

Howard Park and Dwayne Fuller

August 2002

20030325 059

The contents of this report are not to be used for advertising, publication, or promotional purposes. Citation of trade names does not constitute an official endorsement or approval of the use of such commercial products.

The findings of this report are not to be construed as an official Department of the Army position, unless so designated by other authorized documents.



PRINTED ON RECYCLED PAPER

ERDC/CHL TR-02-13  
August 2002

# **Navigation Conditions in Lower Lock Approach of Ice Harbor Lock and Dam, Snake River, Washington**

by Howard Park, Dwayne Fuller

Coastal and Hydraulics Laboratory  
U.S. Army Engineer Research and Development Center  
3909 Halls Ferry Road  
Vicksburg, MS 39180-6199

Final report

Approved for public release; distribution is unlimited

Prepared for U.S. Army Engineer District, Walla Walla  
201 North 3<sup>rd</sup> Avenue  
Walla Walla, WA 99362

# Contents

---

Preface.....	v
Conversion Factors, Non-SI to SI Units of Measurement.....	vi
1—Introduction .....	1
Location and Description of Prototype.....	1
History of Project.....	1
Need and Purpose of Model Study .....	3
2—Physical Model Description .....	4
Scale Relations.....	4
Appurtenances .....	5
Navigation Verification .....	5
3—Tests and Results.....	6
Test Procedures.....	6
Base Tests with Existing Conditions (No Deflectors) .....	7
Description .....	7
Results .....	7
Four Deflectors Installed on Gate Bays 4-7.....	9
Description .....	9
Results .....	10
Eight Deflectors Installed on Gate Bays 2-9.....	11
Description .....	11
Results .....	11
Ten Deflectors Installed on Gate Bays 1-10 .....	12
Description .....	12
Results .....	13
Ten Deflectors Installed on Gate Bays 1-10 and Four Cells Downstream of Lower Guard Wall.....	14
Description .....	14
Results .....	14
Intermediate Alternatives Investigated .....	15
4—Conclusions .....	21
Ice Harbor Lock and Dam Conclusions.....	21
Impacts on navigation due to flow deflectors.....	21
Navigation improvements .....	21

Appendix A: Miscellaneous Information for Designed Construction  
of Lower Lock Approach Coffers .....A1

Plates 1-80

SF 298

## List of Figures

---

Figure 1.	Location map .....	2
Figure 2.	Existing condition .....	4
Figure 3.	Base test with existing conditions, original spillway .....	8
Figure 4.	Flow deflectors installed on gate bays 4 - 7, gates bays 3 and 8 inoperable .....	9
Figure 5.	Flow deflectors installed on gate bays 2 - 9.....	11
Figure 6.	Flow deflectors installed on gate bays 1 - 10, training wall between gate bays 9 and 10 .....	13
Figure 7.	Four circular sheet pile cells placed downstream of lower guard wall .....	14
Figure 8.	Type 1 design rock dike configuration .....	16
Figure 9.	Type 2 design rock dike configuration .....	16
Figure 10.	Type 3 design rock dike configuration .....	16
Figure 11.	Typography modification .....	17
Figure 12.	Splitter wall between the gated spillway and the powerhouse.....	18
Figure 13.	Modifications to existing guard wall .....	18
Figure 14.	Removal of wing off existing guard wall .....	19
Figure 15.	Extension to existing guard wall (330 ft).....	19
Figure 16.	Type 4 design guide wall.....	19
Figure 17.	Type 6 design guide wall.....	20
Figure 18.	Type 7 design guide wall.....	20
Figure 19.	Type 8 design guide wall.....	20

# Preface

---

The model investigation described herein was conducted for the U.S. Army Corp of Engineer District, Walla Walla, by the U.S. Army Engineer Research and Development Center (ERDC), Vicksburg, MS. The study was conducted in the Coastal and Hydraulics Laboratory (CHL) during the period of June 1997 to December 1997. Dr. James R. Houston was the Director of CHL and Mr. Charles C. Calhoun, Jr., was the Assistant Director.

During the course of the model study, representatives of the Walla Walla District and other navigation interest visited ERDC at various times to observe the model and discuss tests results. The Walla Walla District was informed of the progress of the model study through monthly progress reports.

The model study was conducted under the direct supervision of Dr. Larry L. Daggett, Chief of the Navigation Division, CHL. The principal investigator in immediate charge of the navigation portion of the model study was Mr. H.E. Park, assisted by Mr. K. Green, and Ms. D. George of the Navigation Division, and Messrs. D. Fuller, D. White, and J. Williams of the Hydraulic Structures Division. This report was prepared by Messrs. H. Park and D. Fuller.

At the time of publication of this report, Dr. James R. Houston was Director of ERDC, and COL John W. Morris III, EN, was Commander and Executive Director.

*The contents of this report are not to be used for advertising, publication, or promotional purposes. Citation of trade names does not constitute an official endorsement or approval of the use of such commercial products.*

# Conversion Factors, Non-SI to SI Units of Measurement

---

Non-SI units of measurement used in figures, plates, and tables of this report can be converted to SI units as follows:

<b>Multiply</b>	<b>By</b>	<b>To Obtain</b>
cubic feet	0.02831685	cubic meters
degrees (angle)	0.01745329	radians
feet	0.3048	meters
miles (U.S. statute)	1.609347	kilometers
square miles	2.5890	square kilometers

# 1 Introduction

---

## Location and Description of Prototype

Ice Harbor Lock and Dam is located on the Snake River about 9.7 miles upstream of its confluence with the Columbia River (Figure 1). The project is the first multipurpose dam encountered on the Snake River. The project uses include power generation, navigation, and flood control.

The principal existing structures at the project site include a navigation lock with a clear chamber dimension of 86 ft<sup>1</sup> by 675 ft and a 103-ft lift, a gated spillway with ten 50-ft-wide gate bays, and a powerhouse with six units capable of generating 603,000 kW of power.

## History of Project

The Corps of Engineers and others have constructed 18 dams along the Columbia and Snake River system since 1933. These dams have been constructed to provide electric power, flood control, irrigate farmland, and extended barge traffic. However, while providing these benefits, the dams have also had some impacts on annual fish migrations, particularly salmon and steelhead trout.

With the creation and operation of hydropower dams on the Columbia-Snake River system, the number of migrating fish returning to their hatching ground have declined. During the migration of these fish from the sea upriver to their spawning grounds, these anadromous fish face numerous hazards, one of which is termed gas bubble trauma. Gas bubble trauma is caused by high levels of dissolved gas and can be fatal to these migratory fish.

The U.S. Army Corps of Engineers is currently investigating several structural modifications to these dams to reduce dissolved gases. One structural modification that has been implemented is spillway flow deflectors on the gated portion of several dams. While reducing the level of dissolved gas, these flow deflectors change the flow conditions in the tailrace.

---

<sup>1</sup> A table of factors for converting non-SI units of measurement to SI units is presented on page vi.

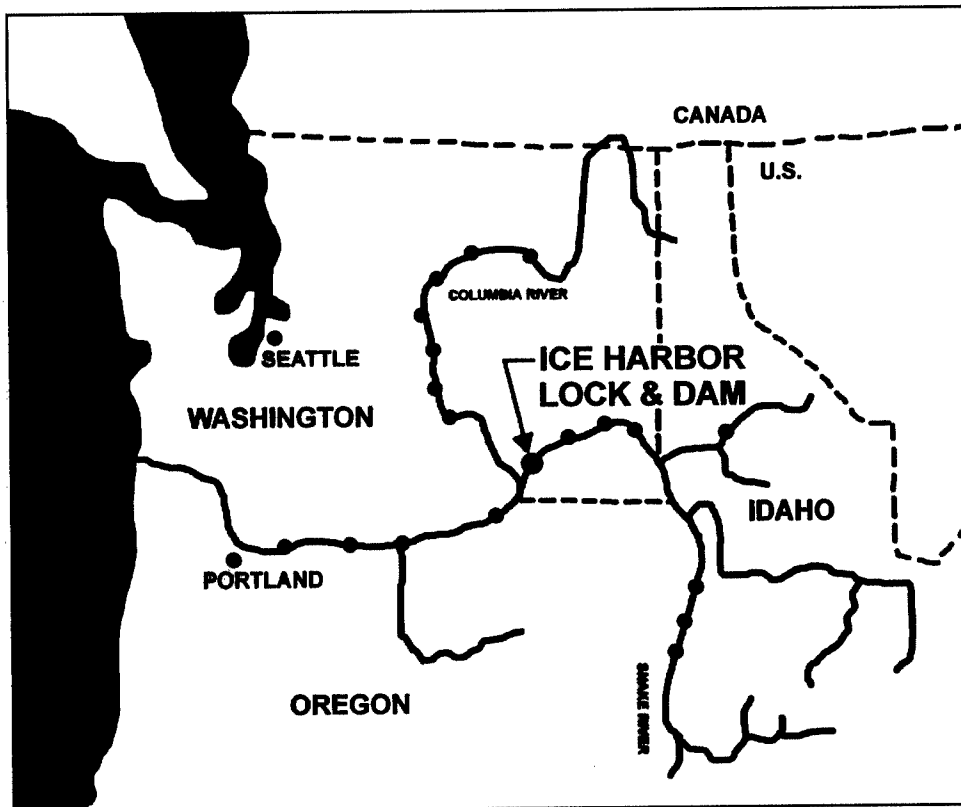

Figure 1. Location map

The installation of the flow deflectors (completed in 1998) at the Ice Harbor project has increased the magnitude and angle of the crosscurrent in the lower lock approach during spillway releases. The flow deflectors have increased the tendency for tows to be pushed toward, and/or to be grounded on the right descending bank. The flow deflectors have in essence reduced the upper limit of navigability at the Ice Harbor lock.

Prior to the addition of the flow deflectors, navigation studies were conducted in 1981 and 1982 by the U.S. Army Engineer Division, North Pacific, Hydraulics Laboratory, at Bonneville, OR, to address the problems associated with the crosscurrents in the lower lock approach. In 1985 and 1986, the navigation channel in the lower lock approach was widened from 250 ft to 350 ft to provide a greater margin of safety.

It was anticipated that the installation of the flow deflectors at the Ice Harbor project would make navigation conditions in the lower lock approach more difficult. During the spring of 1997, time-lapse video documentation and towboat operators confirmed that the flow deflectors had a direct impact on navigation. Flow patterns and current magnitudes in the lower lock approach after the installation of flow deflectors on gate bays 4-7 caused a reduction in the size of the tows exiting the lower lock approach. During the spill season of 1997, spillway patterns were temporarily adjusted to assist downbound tows as they exited the lower lock approach. The navigation industry requested that system

modifications be investigated to resolve or improve navigation difficulties associated with the spillway flow deflectors.

## **Need and Purpose of Model Study**

In 1995, a physical model was constructed at ERDC to investigate alternatives to improve passage of juvenile and adult migratory fish. With the added concerns to navigation, the study was modified to identify the impacts of spillway flow deflectors on barge traffic particularly in the lower lock approach. The plan, although not completed at the time of the publication of this report, is to install flow deflectors on all 10 gate bays. ERDC was tasked with identifying the navigation impacts in the lower lock approach for all 10 flow deflectors and intermediate flow deflector conditions. Once these impacts were identified, ERDC was to investigate structural and hydrographic modifications that could possibly return navigation to predeflector conditions.

## 2 Physical Model Description

The model reproduced about 0.4 miles upstream of the dam and 0.8 miles of the tailrace (Figure 2). The model was constructed with adjacent overbank areas to contain flows with an upper pool elevation up to 450 ft.<sup>1</sup> The model is of the fixed-bed type with the channel and overbank areas molded in a sand-cement mortar and was molded to sheet metal templates. The lock, dam, and powerhouse were constructed from sheet metal and Plexiglas.

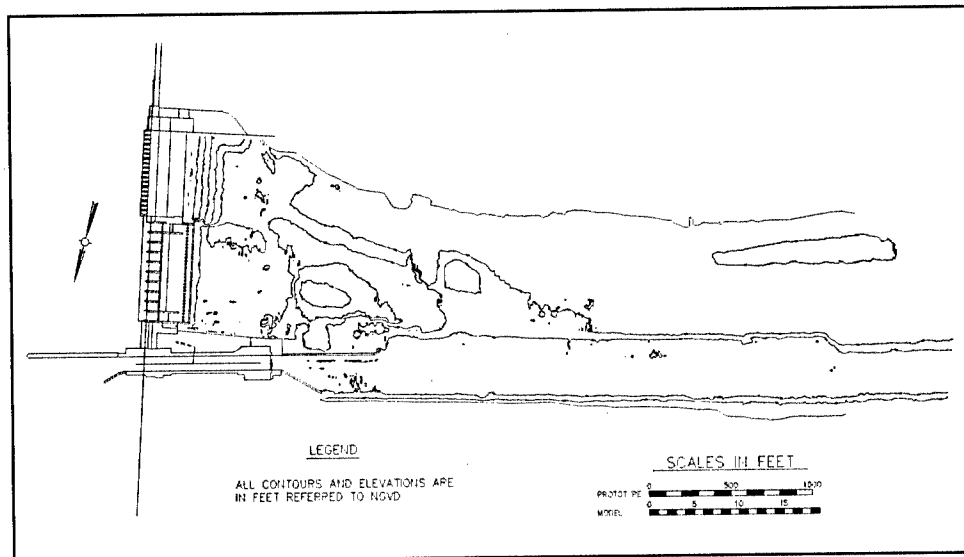

Figure 2. Existing condition

### Scale Relations

The model was built to an undistorted linear scale of 1 ft (model) = 55 ft (prototype). This scale allowed for accurate reproduction of current magnitudes, crosscurrents, and eddies that would affect navigation in the lower lock approach. Other scale relations resulting from the linear scale are given in the following tabulation.

<sup>1</sup> All elevations (el) cited herein are in feet referenced to the National Geodetic Vertical Datum (NGVD) (to convert feet to meters, multiply number of feet by 0.3048).

Characteristic	Ratio	Scale Relation Model: Prototype
Length	$L_r$	1 : 55
Area	$A_r = L_r^2$	1 : 3,025
Velocity	$V_r = L_r^{1/2}$	1 : 7.41
Time	$T_r = L_r^{1/2}$	1 : 7.41
Discharge	$Q_r = L_r^{5/2}$	1 : 22,434
Roughness	$n_r = L_r^{1/6}$	1 : 1.95

These scale relations allow measurements of current magnitudes, discharge, and water-surface elevations to be quantitatively transferred from the model to the prototype.

## Appurtenances

Water was supplied to the model with six pumps, which operate in a recirculating system. The pumps were capable of providing a prototype discharge equivalent to 850,000 cfs. The discharge was measured by a manometer and controlled with a valve. Water-surface elevations were measured in the model with a staff gauge and point gauges. The upper pool elevation was controlled with the spillway and powerhouse and the tailwater elevation was maintained with the model tailgate at the lower end of the model.

Current magnitudes and directions were determined with cylindrical floats drafted to 7-ft and 13-ft prototype. Surface current directions were observed in the model using confetti. A remote controlled model towboat was used to determine the effects of currents on tows entering and leaving the lower lock approach. The towboat was equipped with twin screws and was propelled by small electric motors with a battery in the tow. The towboat could be operated in forward and reverse and at speeds comparable to those using the Columbia-Snake River system.

## Navigation Verification

The existing navigation conditions (deflectors on four spillway bays (4-7)) was verified when the towing industry visited the model and observed the navigation conditions demonstrated to them. All industry representatives in attendance agreed that the model reproduced the navigation conditions in the lower lock approach remarkably well.

Time-lapse video was also recorded at the project during the study providing good insight as to what navigation conditions were in the lower lock approach. The time-lapse video was utilized at strategic times during the study to capture the impacts on navigation during the construction of the remaining six flow deflectors.

## 3 Tests and Results

---

The study of flow patterns, the measurement of current magnitudes and directions, and the effects of currents on the model tow with the installation of flow deflectors on the spillway bays were the primary concern during the navigation phase of the study. These concerns were addressed with base conditions (no deflectors), four deflectors, eight deflectors, and 10 deflectors installed in the spillway bays.

The second objective of the navigation phase of the study was to identify and document alternatives that would improve navigation conditions in the lower lock approach.

### Test Procedures

A representative selection of riverflows were used for testing based on information provided by the U.S. Army Engineer District, Walla Walla. The following tabulation is a list of the riverflows that were used.

Total River Discharge (cfs)	Spillway Discharge(cfs)	PowerhouseDisc harge (cfs)	Upper Pool Elevation (ft)	Tailwater Elevation (ft)
102,300	30,000	72,300	439.0	346.5
117,300	45,000	72,300	439.0	347.7
127,300	55,000	72,300	439.0	348.3
147,300	75,000	72,300	439.0	349.7
172,300	100,000	72,300	439.0	351.0
197,300	125,000	72,300	439.0	352.5
222,300	150,000	72,300	439.0	353.7

All riverflows tested were steady flow conditions.

Tests were conducted by introducing the proper discharge into the model and maintaining the proper upper pool and tailwater elevations for a given discharge. With all experiments, the upper pool elevation was controlled with a staff gauge located in the upper pool between the lock and the gated spillway and the

tailwater elevation was controlled with a point gauge located downstream of the axis of the dam.

Current directions and velocities were measured using a video tracking system. Current directions were determined by plotting the paths of the floats, and current magnitudes were recorded by timing the travel of the floats over a measured distance. In the areas where turbulence, eddies, and crosscurrents exist, the vector plots only show the main trends in the interest of clarity.

Several tow configurations were used during the course of the study to demonstrate navigation conditions for tows entering and leaving the lower lock approach. For the experiments and model demonstrations the model pusher was 100 ft long. The barge flotillas used during the experiments were as follows:

- a. 1-barge flotilla (42-ft-wide by 274-ft-long by 13-ft draft)
- b. 2-barge flotilla (42-ft-wide by 548-ft-long by 13-ft draft)
- c. 4-barge flotilla (84-ft-wide by 548-ft-long x by 13-ft draft)

The video tracking system was also used to track the path of the model tow through the study reach and aid in evaluating existing and alternative conditions.

## **Base Tests with Existing Conditions (No Deflectors)**

### **Description**

Base tests with existing conditions are shown in Figures 2 and 3 and consist of the following principal features:

- a. A navigation lock on the right descending bank having clear chamber dimensions of 86 ft by 675 ft. An upstream floating guard wall and a non-ported lower guard wall extending about 1,425 ft from the spillway axis.
- b. A gated spillway with ten 50-ft-wide gate bays with crest el 391. The gated spillway is separated from the lock by about 162 ft.
- c. A powerhouse adjacent to the gated spillway near the left descending bank having six power generating units. For these experiments unit No.5 was not operating.

### **Results**

**Current direction and velocities.** Current direction and velocity data and isovel color plots for base tests with existing conditions are shown in Plates 1-10.

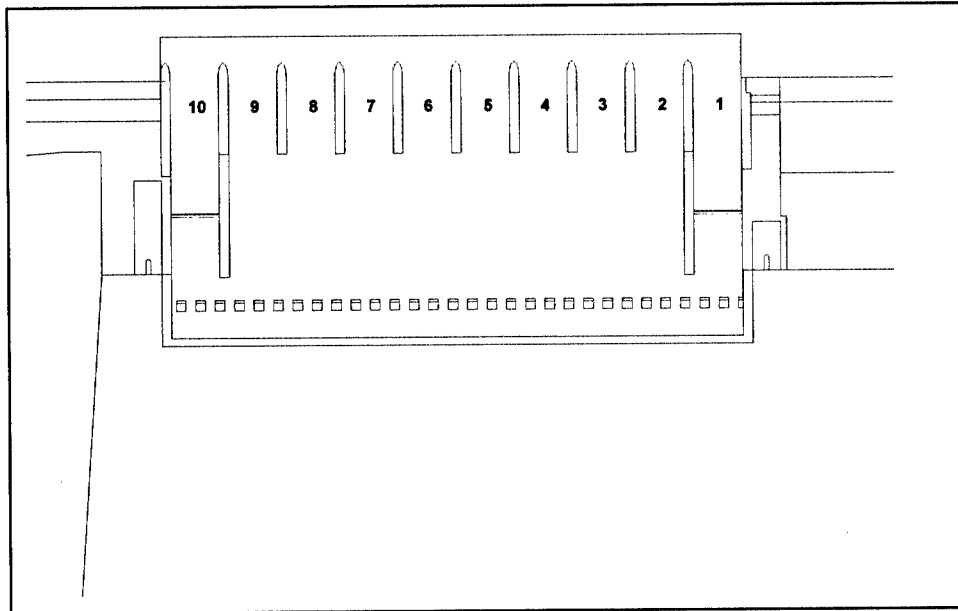

Figure 3. Base test with existing conditions, original spillway

With all riverflows tested, two large eddies, one clockwise and one counter-clockwise, formed in the lower lock approach. In general, the clockwise eddy extended downstream to approximately sta 21+00. The eddies in the lower lock approach varied in intensity. The upstream velocity of the eddy ranged from about 0.5 fps to 3.6 fps. There was also an eddy that developed riverward of the south wall and appeared to increase in size as the river discharge increased.

The angle of crosscurrent in the lower lock approach (referenced to the center line of the lock) ranged from about 15 to 25 deg. The magnitude of currents moving across the lower lock approach ranged from about 6.0 fps with a riverflow of 102,300 cfs to about 12.0 fps with a riverflow of 172,300 cfs. Average current magnitudes in the excavated channel downstream of the lock at approximately sta 35+00 ranged from about 5.5 fps to 10.5 fps with riverflows of 102,300 cfs and 172,300 cfs, respectively.

**Navigation conditions, lower lock approach.** Navigation conditions in the lower lock approach were evaluated using three barge configurations with three different discharges. They were as follows: a) four-barge tow with riverflow of 102,300 cfs. b) two-barge tow with riverflow of 127,300 cfs. c) one-barge tow with 172,300 cfs. This was identified as the general practice at the Ice Harbor lock prior to installation of any flow deflectors.

**Downbound tows.** Navigation conditions for a four-barge tow leaving the lower lock approach were considered satisfactory with a riverflow of 102,300 cfs. There was a tendency for the tow to be moved toward the right bank at approximately sta 20+00 and 25+00 (Plate 11). As the discharge increased to 127,300 cfs, the tow size was reduced to two barges, and navigation conditions became more difficult. The tendency for downbound tows to encroach on the right bank was more evident. Provided the tow could get up to current speed and

steer toward midchannel, downbound two-barge tows could stay off the right bank (Plate 13). With a riverflow of 172,300 cfs, the tow size was reduced to one barge. Downbound tows experienced difficulty attempting to stay off the right bank and could often become grounded on the right bank approximately at sta 30+00 (Plate 14).

**Upbound tows.** With a riverflow of 102,300 cfs and for a two- and four-barge tow (Plates 15-16), navigation conditions entering the lower lock approach were satisfactory. Crosscurrents approximately at sta 20+00 to 25+00 did require some maneuvering. The clockwise eddy near the downstream guard wall tried to move the head of the tow toward midchannel. Navigation conditions for a two-barge tow and a riverflow of 127,300 cfs (Plate 17) were about the same as those observed for the four-barge tow at a riverflow of 102,300 cfs. The crosscurrent in the lower lock approach appeared to be a little stronger, and the eddies near the guard wall appeared to have intensified. As the riverflow increased to 172,300 cfs and the tow size was reduced to one barge (Plate 18), acceptable navigation conditions for upbound tows entering the lower lock approach were considered marginally adequate. The crosscurrent was strong and the currents were unstable. The intensity and size of the eddies near the guard wall in the lower lock approach was strong and caused difficulties for upbound tows entering the lock.

## Four Deflectors Installed on Gate Bays 4-7

### Description

The four-deflector plan is the same as base tests with one exception. Flow deflectors were installed on gate bays 4 through 7, and gate bays 3 and 8 were inoperable (Figure 4).

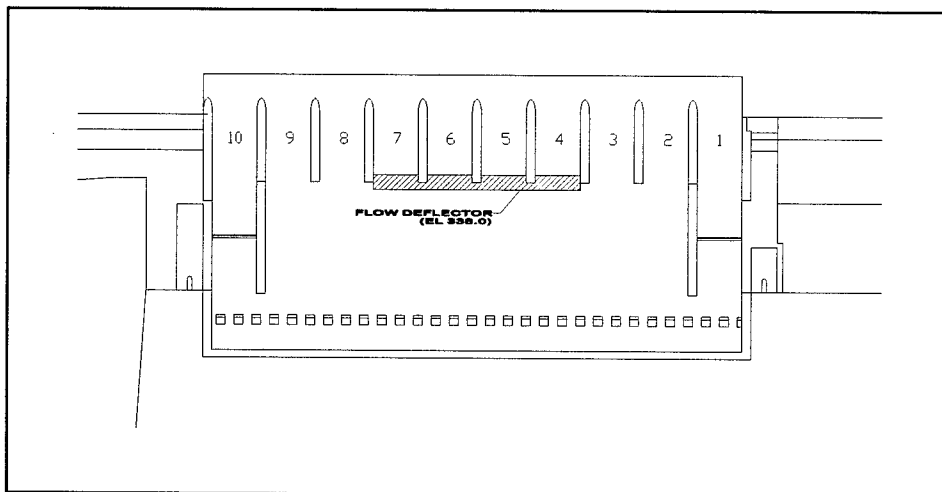

Figure 4. Flow deflectors installed on gate bays 4 - 7, gates bays 3 and 8 inoperable

## Results

**Current direction and velocities.** Current direction and velocity data and isovel color plots are shown in Plates 19-28. With all riverflows tested, two large eddies, one clockwise and one counter clockwise, formed in the lower lock approach. In general, the clockwise eddy extended downstream approximately to sta 21+00. The eddies in the lower lock approach varied in intensity and appeared to increase in both size and intensity when compared to base tests. Two large eddies were also observed riverward of the south wall of the lock. The upstream velocity of the eddies in the lower lock approach ranged from about 1.3 fps with riverflow of 102,300 cfs to 5.2 fps with riverflow of 172,300 cfs. The intensity of these circulation patterns appear to be the direct result of the installation of the flow deflectors on gate bays 4-7.

The angle of crosscurrent in the lower lock approach ranged from about 21 to 26 deg. The magnitude of currents moving across the lower lock approach ranged from about 7.6 fps with a riverflow of 102,300 cfs to about 13.0 fps with a riverflow of 172,300 cfs. Average current magnitudes in the excavated portion of the existing channel downstream of the lock at approximately sta 35+00, ranged from about 7.5 fps to 12.7 fps with riverflows of 102,300 cfs and 172,300 cfs, respectively.

The angle of the crosscurrent in the lower lock approach increased about 6 deg and the magnitude increased about 1.5 fps when compared to base tests.

**Navigation conditions, lower lock approach.** At the time of this study, four deflectors had been installed on gate bays 4 through 7 in the prototype at Ice Harbor Dam. Because of difficulties entering and leaving the lower lock approach, current practice among the towing industry was to reduce the tow sizes according to spillway discharge. With four deflectors installed, the riverflow and tow sizes for these experiments were as follows: a) two-barge tow with riverflow of 102,300 cfs. b) two-barge tow with riverflow of 127,300 cfs. c) one-barge tow with 172,300 cfs. Four-barge tows were not used after installation of the four flow deflectors as tested with base conditions.

**Downbound tows.** Current direction and velocity data indicated that the crosscurrent in the lower lock approach was stronger than those observed with existing conditions. With a riverflow of 102,300 cfs and a two-barge tow (Plate 29), the tow had a tendency to be pushed toward the right bank at approximately sta 20+00 to 25+00. As the riverflow increased to 127,300 cfs with a two-barge tow, downbound tows experienced a stronger push toward the right bank and began to encroach on the bank (Plate 30). With a riverflow of 172,300 cfs and one-barge tow, navigation conditions became increasingly more difficult because of high velocity crosscurrents in the lower lock approach. Downbound tows were required to take a hard set and steer toward midchannel to avoid grounding on the right bank (Plate 31). With all experiments that were observed, it appeared that achieving maximum speed leaving the lower lock approach was the key to staying off the right descending bank.

**Upbound tows.** Navigation conditions for tows entering the lower lock approach were difficult with all riverflows tested because of two factors: the eddies in the lower lock approach caused some maneuvering problems both entering and exiting the lock: and the current magnitudes in the lower approach were very high as the discharge increased. Upbound tows pushing upstream against high velocity currents suddenly entered the eddies where the current was pulling the tow upstream and toward the end of the guard wall (Plates 32-34). With the unstable currents and the eddies in the lower lock approach, navigation conditions for tows entering the lower lock approach could be considered unacceptable in some situations.

## Eight Deflectors Installed on Gate Bays 2-9

### Description

The eight-deflector plan is the same as base tests with one exception. Flow deflectors were installed on gate bays 2 through 9 (Figure 5).

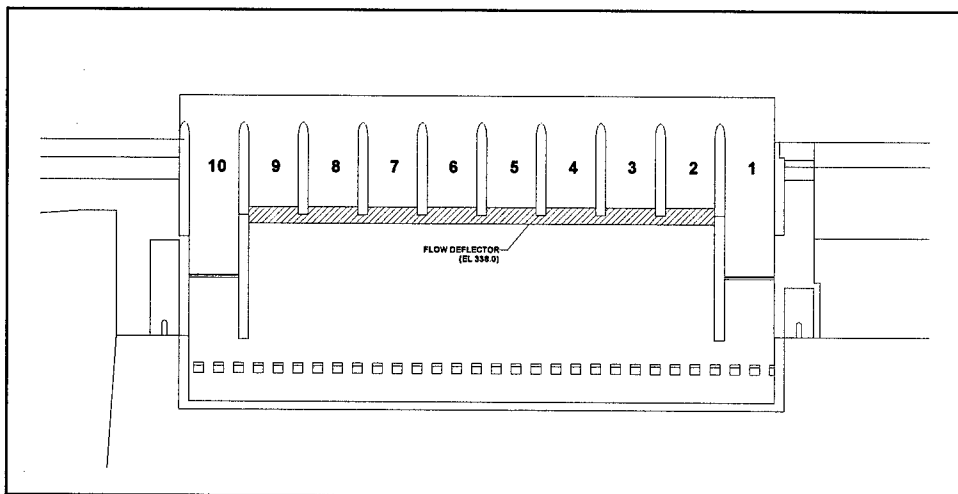

Figure 5. Flow deflectors installed on gate bays 2 - 9

### Results

**Current direction and velocities.** Current direction and velocity data and isovel color plots are shown in Plates 35-46. With all riverflows tested, two large eddies, one clockwise and one counter clockwise, formed in the lower lock approach. In general, the clockwise eddy extended downstream to approximately sta 24+00. The eddies in the lower lock approach varied in intensity and appeared to increase in size when compared to base tests, in particular with a riverflow of 127,300 cfs. The upstream velocity of the eddy ranged from about 2.4 fps to 5.6 fps. The strength and intensities of these eddies in the lower lock approach appeared to be a direct result of the installation of flow deflectors on the gated spillway.

The angle of crosscurrent in the lower lock approach ranged from about 24 to 35 deg. The magnitude of currents moving across the lower lock approach ranged from about 7.0 fps with a riverflow of 102,300 cfs to about 11.5 fps with a riverflow of 127,300 cfs. Average current magnitudes in the excavated channel downstream of the lock at approximately sta 35+00 ranged from about 6.2 fps to 10.1 fps with riverflows of 102,300 cfs and 172,300 cfs, respectively.

The angle of the crosscurrent in the lower lock approach increased about 5 to 9 deg and the magnitude of the crosscurrent decreased slightly when compared to the four-deflector arrangement.

**Navigation conditions, lower lock approach.** The same tow size and riverflow relationships were tested with the eight deflectors installed as were tested with the four-deflector arrangement.

**Downbound tows.** With a riverflow of 102,300 cfs and a two-barge tow, navigation conditions leaving the lower lock approach were satisfactory (Plate 47). However, the tow experienced a tendency to be moved toward the right bank at approximately sta 20+00 to 25+00. As the riverflow increased to 127,300 cfs (Plate 48), a two-barge tow leaving the lower lock approach experienced a hard push toward the right bank and in some instances encroached very close to the right bank. The eddy just downstream of the guard wall appeared to have some impacts on tows leaving. The eddy would rotate the tow toward the guard upon exit. With a one-barge tow and riverflow of 172,300 cfs, acceptable navigation conditions for downbound tows were considered very marginal. The eddy just downstream of the guard wall strongly rotated the tow counterclockwise upon exit. The tow often encroached on the right descending bank near sta 25+00 (Plate 49).

**Upbound tows.** Navigation conditions for tows entering the lower lock approach were about the same as those observed with the four-deflector plan. The unstable eddies and high velocity currents in the lower lock approach caused significant difficulties for tows entering the lock (Plates 50-52). This tendency was particularly noticeable with riverflows of 127,300 cfs and above. Due to the instability of the flow conditions in the lower lock approach, the navigation conditions could be considered unacceptable.

## **Ten Deflectors Installed on Gate Bays 1-10**

### **Description**

The 10-deflector plan is the same as base tests with two exceptions. Flow deflectors were installed on gate bays 1 through 10 and the training wall between gate bays 9 and 10 was extended about 70 ft to the end sill (Figure 6). This configuration was considered the optimum design for fish passage.

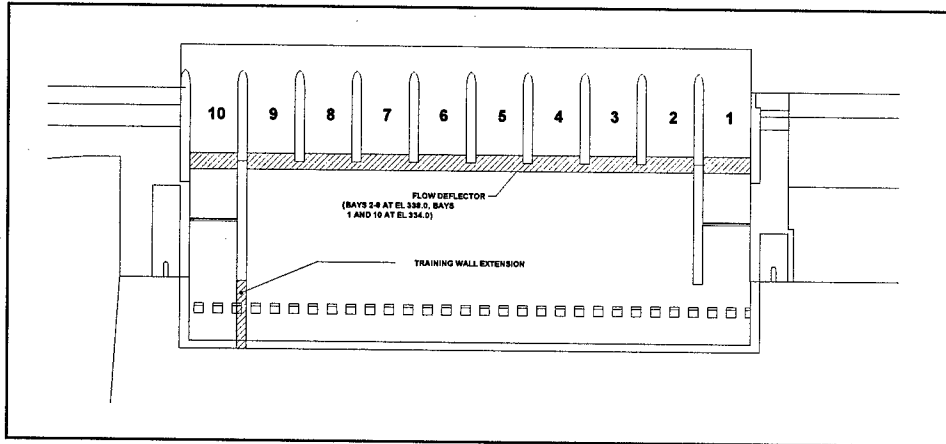

Figure 6. Flow deflectors installed on gate bays 1 - 10, training wall between gate bays 9 and 10

## Results

**Current direction and velocities.** Current direction and velocity data and isovel color plots are shown in Plates 53-62. With all riverflows tested, two large eddies, one clockwise and one counterclockwise, formed in the lower lock approach. In general, the clockwise eddy extended downstream to approximately sta 22+50. The eddies in the lower lock approach varied in intensity. The upstream velocity of the eddy ranged from about 1.1 fps to 4.3 fps. There was also an eddy that developed riverward of the south wall and appeared to increase in size as the river discharge increased.

The angle of crosscurrent in the lower lock approach ranged from about 19 to 28 deg. The magnitude of currents moving across the lower lock approach ranged from about 7.5 fps with a riverflow of 102,300 cfs to about 11.5 fps with a riverflow of 127,300 cfs. Average current magnitudes in the excavated channel downstream of the lock at approximately sta 35+00 ranged from about 6.3 fps to 9.2 fps with riverflows of 102,300 cfs and 172,300 cfs, respectively.

The angle of the crosscurrent in the lower lock approach was reduced about 6 deg and the magnitude of the crosscurrent was about the same when compared to the eight-deflector arrangement.

**Navigation conditions, lower lock approach.** The same tow size and riverflow relationships were tested with the 10 deflectors installed as were tested with the four- and eight-deflector arrangement.

**Downbound tows.** Navigation conditions for tows leaving the lower lock approach appeared to improve when compared to the eight-deflector arrangement. Current direction and velocity data indicated a reduction in the angle of the crosscurrent in the lower lock approach and a slight reduction in the intensity of the eddies near the downstream guard wall. With riverflow of 102,300 cfs and a two-barge tow, navigation conditions were satisfactory (Plate 63). There was a tendency for the tow to be pushed toward the right bank near sta 25+00. As the

riverflow increased, the tendency for tows to be pushed toward the right bank was more pronounced (Plates 64 and 65). Navigation conditions for tows leaving the lower lock approach were considered satisfactory, but not without some difficulties.

**Upbound tows.** With riverflows up through 127,300 cfs, navigation conditions for tows entering the lower lock approach were satisfactory. However, attention should be given to the eddies working near the downstream end of the guard wall. These eddies caused some difficulties maintaining alignment with the guard wall (Plates 66 and 67). As the riverflow increased to 172,300 cfs and one-barge tow, acceptable navigation conditions were marginal because of difficulties with the unsteady eddies in the lower lock approach (Plate 68).

## Ten Deflectors Installed on Gate Bays 1-10 and Four Cells Downstream of Lower Guard Wall

### Description

This plan is the same as the 10-deflector plan (Figure 6) with one exception. Four circular sheet pile cells were placed downstream and riverward of the lower guard wall as shown in (Figure 7).

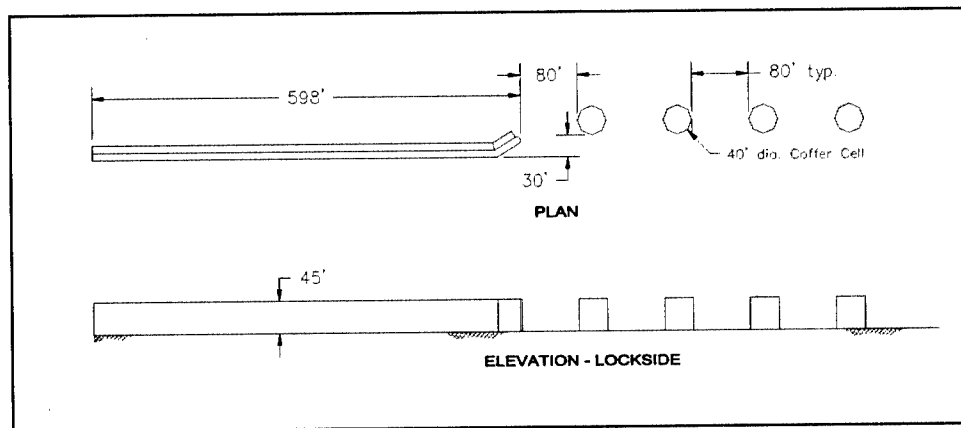

Figure 7. Four circular sheet pile cells placed downstream of lower guard wall

### Results

**Current direction and velocities.** Current direction and velocity data and isovel color plots are shown in Plates 69-74. These data indicated that the addition of the four cells downstream of the lower guard wall had a significant impact on the angle of attack and the velocity of the crosscurrent in the lower lock approach. Although the cells did not eliminate the eddies in the lower approach, the data indicated a reduction in the strength of the eddies in the lower lock approach when compared to all other plans. The upstream velocity of the eddy ranged from about 1.3 fps with a riverflow of 102,300 cfs to 2.3 fps with a

riverflow of 172,300 cfs. The training wall extension between gate bays 9 and 10 (Figure 6) significantly reduced the eddy riverward of the south wall.

The angle of crosscurrent in the lower lock approach ranged from about 9 to 18 deg with riverflows of 127,300 cfs and 172,300 cfs, respectively. The magnitude of currents moving across the lower lock approach ranged from about 5.0 fps with a riverflow of 102,300 cfs to about 8.0 fps with a riverflow of 172,300 cfs. Average current magnitudes in the excavated channel downstream of the lock at approximately sta 35+00 ranged from about 6.0 fps to 9.0 fps with riverflows of 102,300 cfs and 172,300 cfs, respectively.

The addition of the four cells in the lower lock approach reduced the angle of the crosscurrent about 10 deg and significantly reduced the magnitude of the crosscurrent (about 2.5 to 3.0 fps) when compared to the 10-deflector arrangement without the four cells.

**Navigation conditions, lower lock approach.** Though not used in previous deflector plans, navigation conditions were evaluated using a four-barge tow for all riverflows tested. Horsepower, achievable speed, pilot discretion, and other factors would determine whether or not it could be recommended to leave or enter the lock with four barges. These tests did demonstrate the improvements made with the placement of four circular cells in the lower lock approach.

**Downbound tows.** Navigation conditions for a downbound four-barge tow are shown in Plates 75-77. With a riverflow of 102,300 cfs, navigation conditions were satisfactory (Plate 75). As the riverflow increased to 127,300 cfs and above, the tow was pushed toward the right bank (Plate 76 and 77). Although the tow was pushed toward the right bank, the tow did not encroach on the right bank as much as observed with all other plans. The eddies in the lower lock approach had some effect on the tows while leaving the lock, but were not considered adverse. The cells provided a sheltered area and allowed downbound tows to achieve as much speed as possible before entering the crosscurrent.

**Upbound tows.** Navigation conditions for upbound four-barge tows were satisfactory with all riverflows tested (Plates 78-80). The crosscurrent and eddies in the lower lock approach did not have any significant adverse impacts on upbound tow traffic.

## Intermediate Alternatives Investigated

Numerous intermediate experiments were performed on the model in an effort to meet or exceed the predeflector navigation conditions in the lower lock approach at Ice Harbor.

Several rock dike configurations were experimented with and none proved beneficial toward improving navigation. Figures 8-10 show some of the rock dike modifications that were investigated.

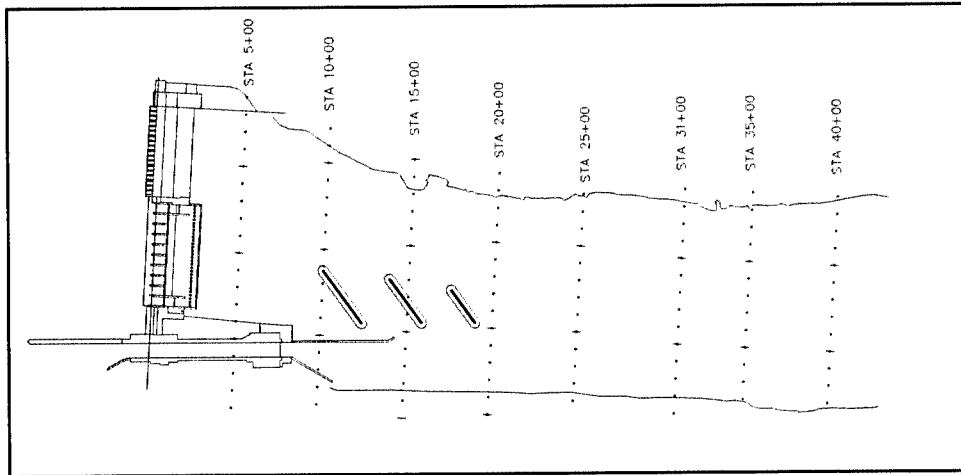

Figure 8. Type 1 design rock dike configuration

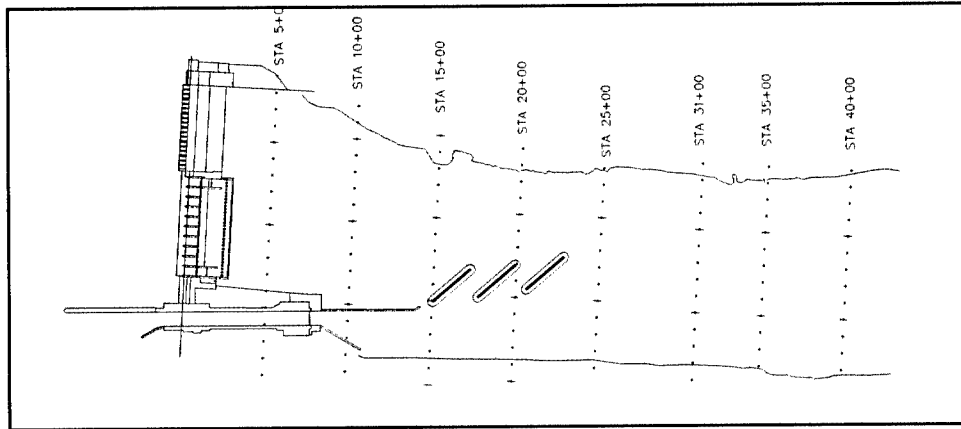

Figure 9. Type 2 design rock dike configuration

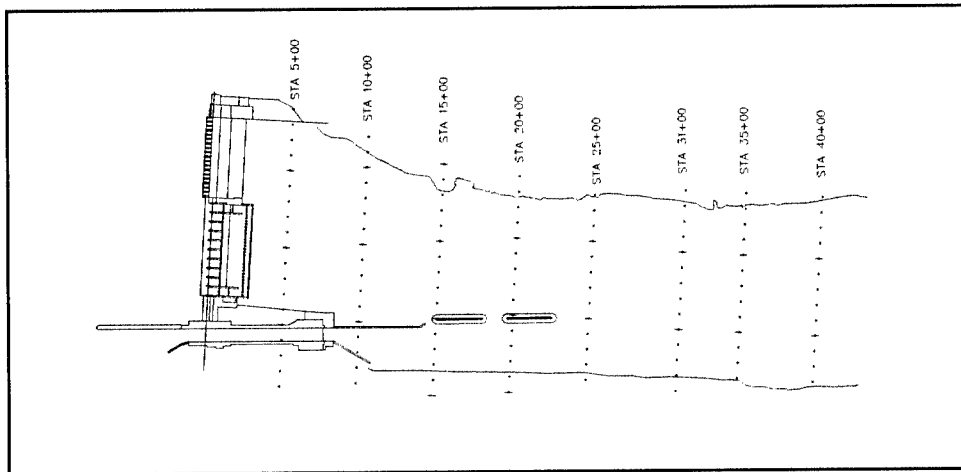

Figure 10. Type 3 design rock dike configuration

Figure 11 shows some of the topography modifications to the model that were tried but made no significant improvements to navigation conditions into the lower lock approach.

Figure 12 shows a splitter wall that was added between the gated spillway and the powerhouse. It, too, showed no improvements to the navigation conditions.

Several modifications were made to the existing downstream guard wall (Figure 13). Figure 14 shows the removal of the wing off the existing guard wall. Figure 15 shows a 330-ft extension to the existing guard wall. Neither of these modifications improved the postdeflector navigation conditions.

The modification that appeared to have the most benefit to navigation conditions in the lower lock approach was the placement of circular coffer cells just downstream of the guard wall. Figures 16 and 17 show the arrangement of the coffer cells investigated. Of the three coffer cell configurations, the four-cell arrangement was considered the optimum (Figure 7).

Based on the success of the coffer cell configurations, alternative modifications were investigated which included the placement of large stone in a fashion similar to the four-coffer cell configuration. Figures 18 and 19 show the modifications investigated. However, the rock configurations did not show any improvements to the postdeflector navigation conditions.

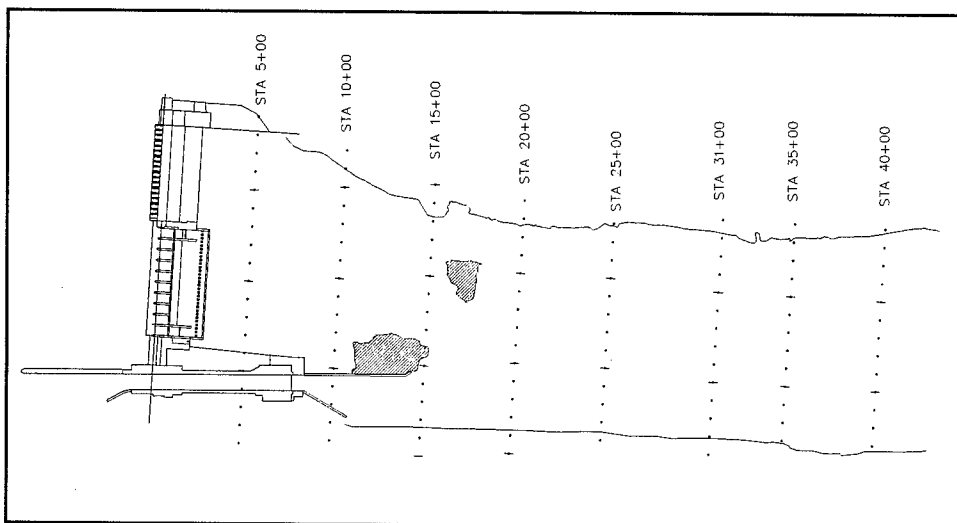

Figure 11. Topography modification

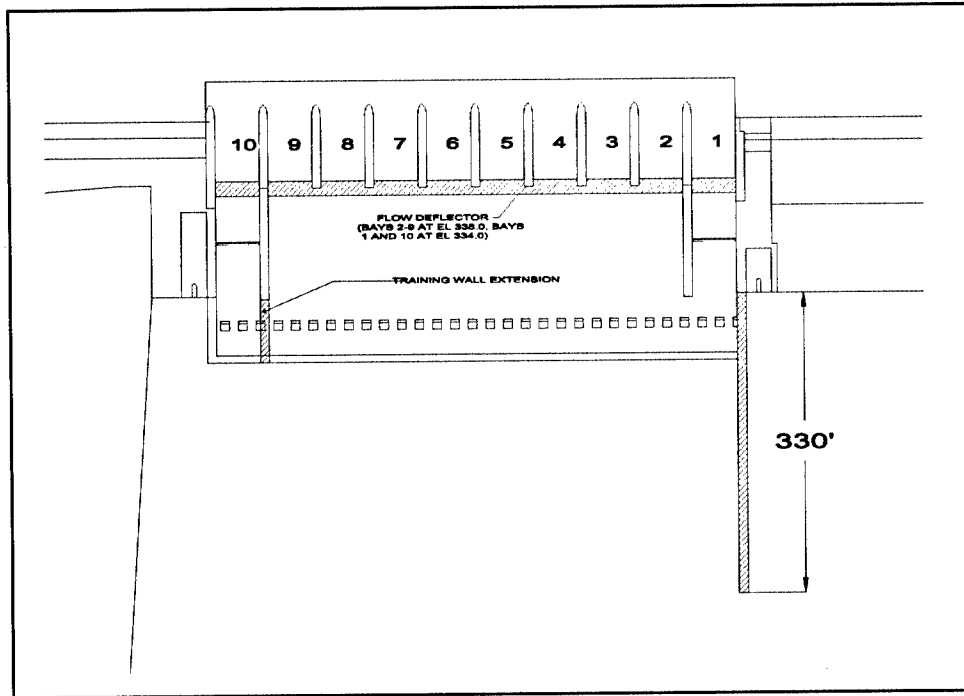

Figure 12. Splitter wall between the gated spillway and the powerhouse

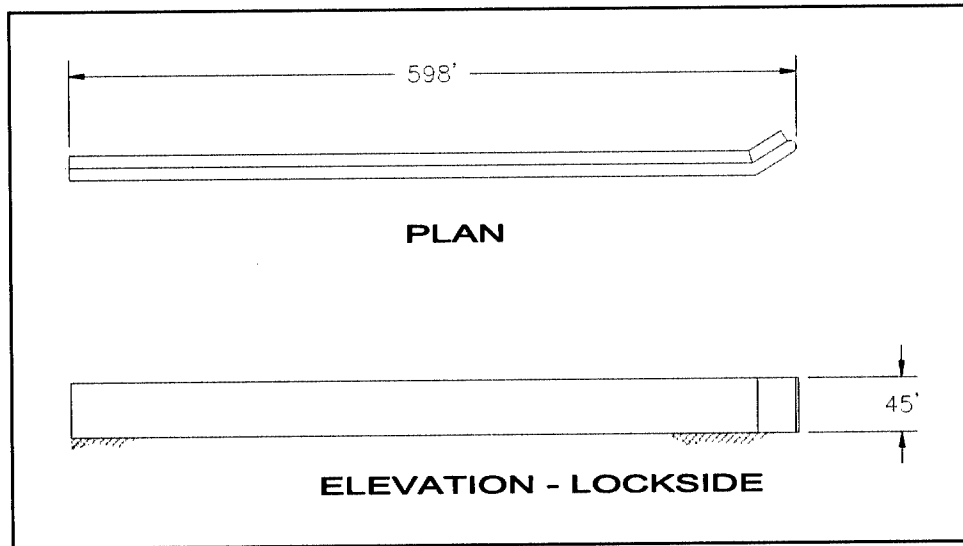

Figure 13. Modifications to existing guard wall

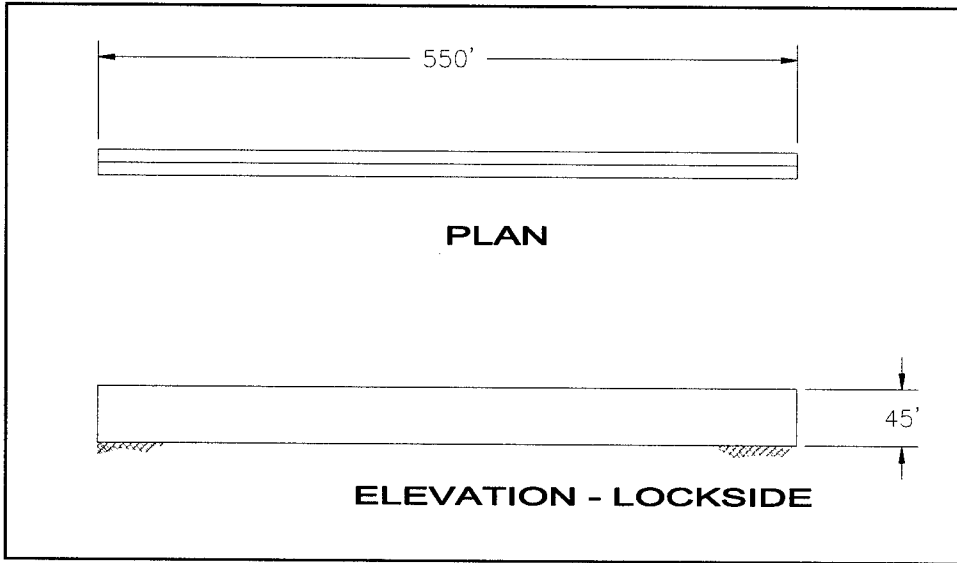

Figure 14. Removal of wing off existing guard wall

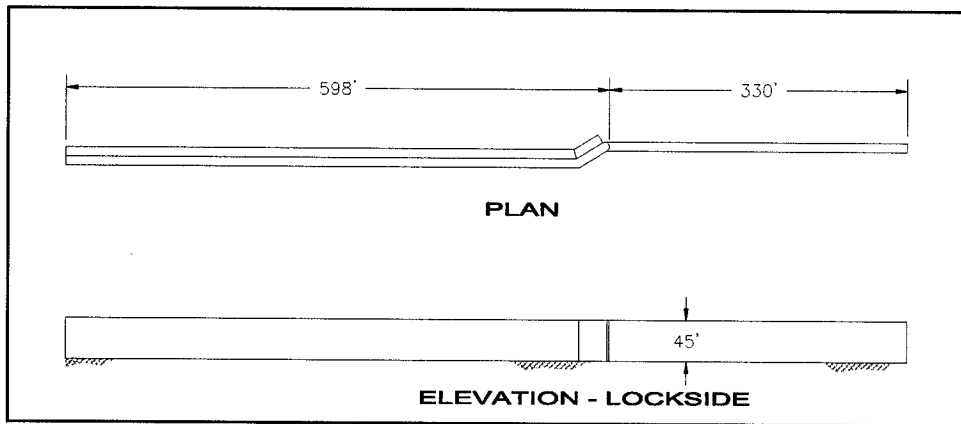

Figure 15. Extension to existing guard wall (330 ft)

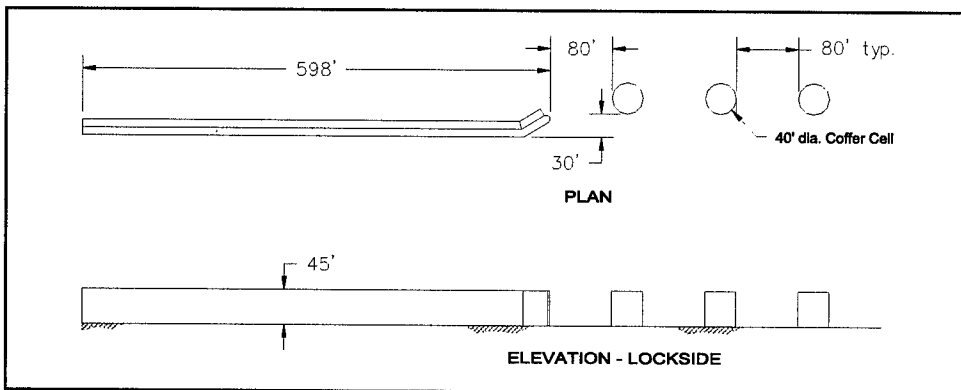

Figure 16. Type 4 design guide wall

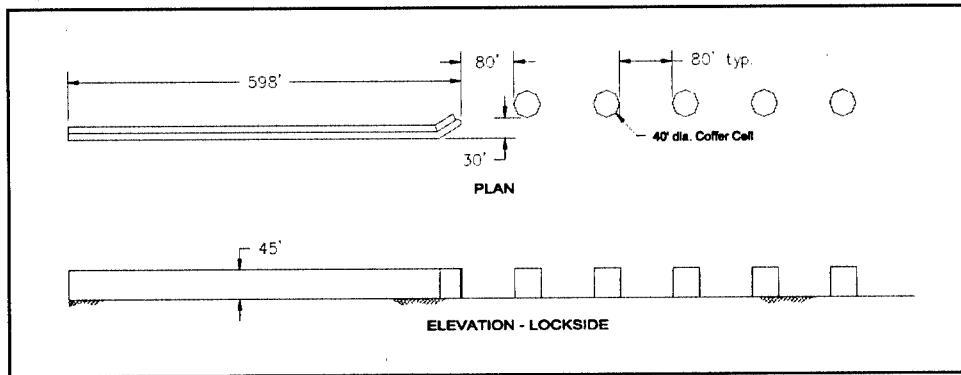

Figure 17. Type 6 design guide wall

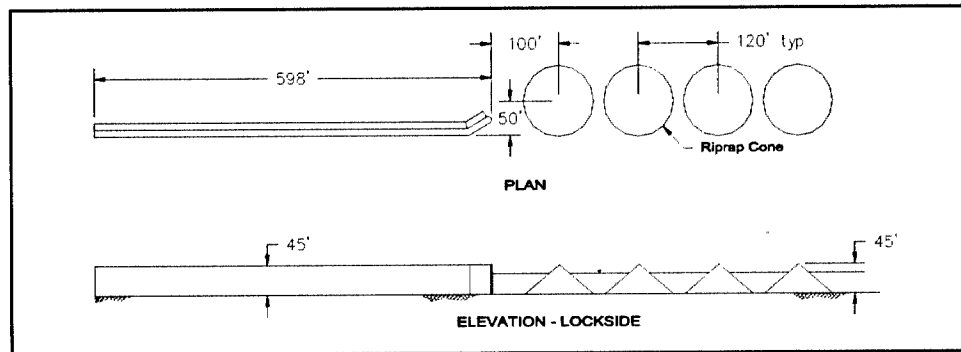

Figure 18. Type 7 design guide wall

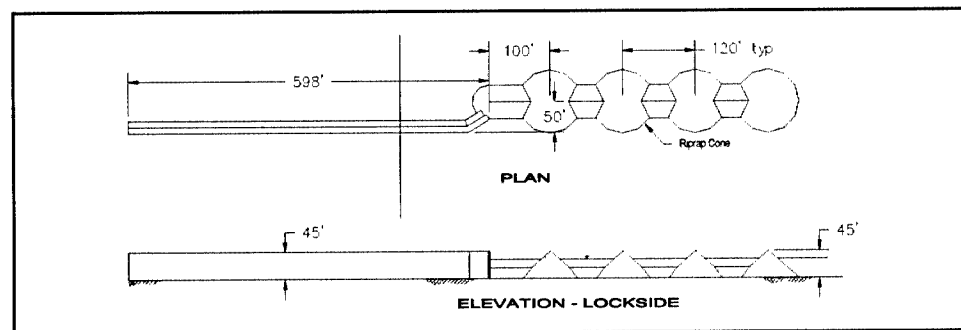

Figure 19. Type 8 design guide wall

# 4 Conclusions

---

The analysis of this investigation's results was based principally on the effects of the installation of flow deflectors on the Ice Harbor dam on current magnitudes and directions, and the effects the resulting currents have on the behavior of the model towboat and barges entering and leaving the lower lock approach.

## Ice Harbor Lock and Dam Conclusions

### Impacts on navigation due to flow deflectors

The installation of flow deflectors at the Ice Harbor dam created adverse impacts to navigation in the lower lock approach. In general, the installation of flow deflectors increased the eddy intensity near the downstream guard wall, and the angle and magnitude of the crosscurrent in the lower lock approach was larger than those observed with the no-deflector conditions.

### Navigation improvements

Several alternatives were investigated to meet or exceed predeflector navigation conditions at the Ice Harbor lock. The recommended improvement is the placement of four, 40-ft-diam circular coffer cells, 120-ft on center, located downstream, parallel, and riverward of the lower guard wall.

The four-coffer cell arrangement reduced both the eddy intensity near the downstream guard wall and the angle and magnitude of the crosscurrents in the lower lock approach. This alternative met the predeflector navigation conditions with the installation and operation of all 10 deflectors. Although navigation conditions were significantly improved with this configuration, it is not a recommendation that four-barge tows could necessarily enter or exit the lock with all riverflows. Other factors such as horsepower, achievable speed, river discharge, and pilot discretion would determine the size of the barge floatilla to enter or exit the lower lock approach.

# **Appendix A Miscellaneous Information for Design and Construction of Lower Lock Approach Coffe Cells**

---

This appendix contains model data to provide engineers from the U.S. Army Engineer District, Walla Walla, information to design and construct the coffer cells in the lower lock approach at the Ice Harbor lock. These data include current direction and velocity, point velocity magnitudes near the coffer cells, and head differential measurements across each coffer cell (Table A1).

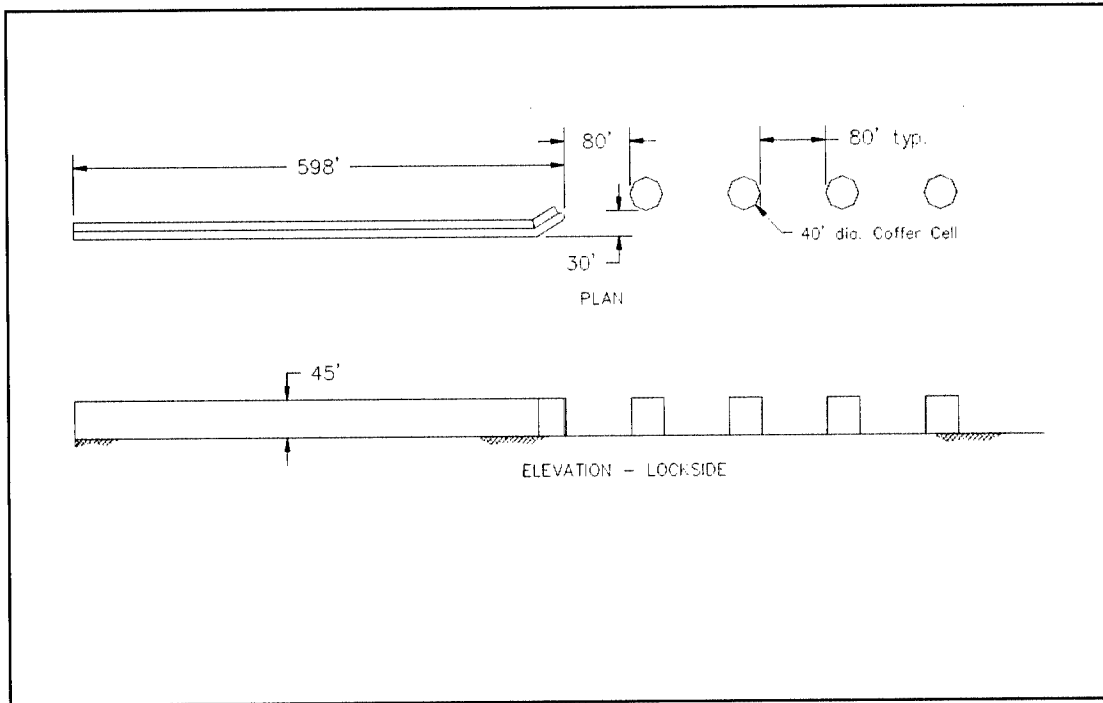

Figure A1. Type 5 guide wall

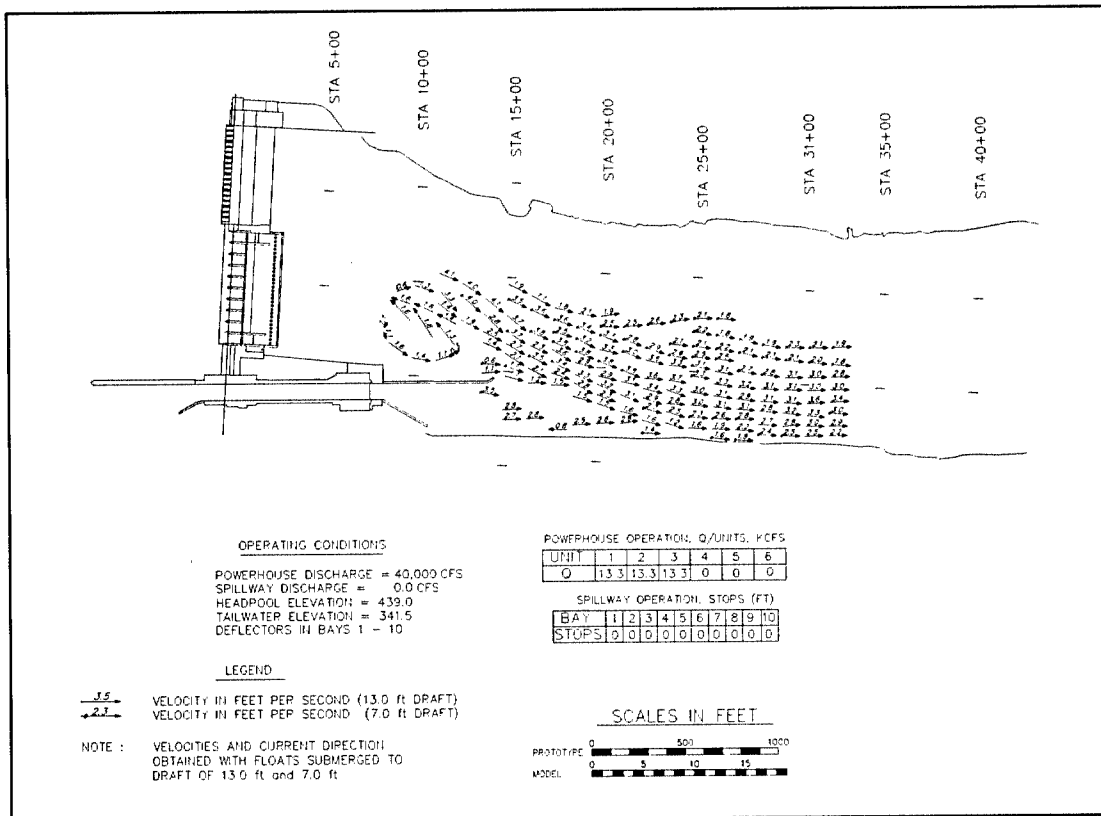

Figure A2. Velocities and current directions, construction flow 1, discharge 40,000 cfs, tailwater 341.5 ft

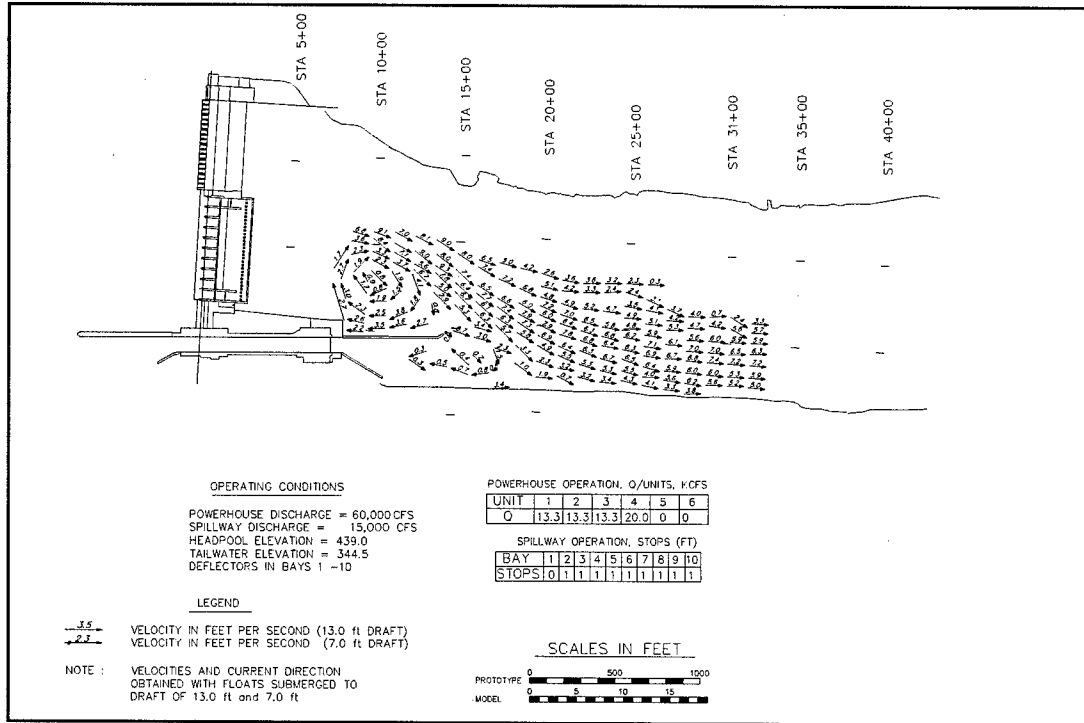

Figure A3. Velocities and current directions, construction flow 2, discharge 75,000 cfs, tailwater 344.5 ft

**Table A1  
Head Differential Across Each Coffee Cell**

Cell <sup>1</sup>	Measurement Location	Water Surface el <sup>2</sup>	Difference from Tailwater el <sup>2</sup>	
			+	-
A	1	366.2	5.0	
	2	356.8		4.4
	3	358.5		2.7
	4	356.3		4.9
B	1	365.1	3.9	
	2	356.38		4.4
	3	356.7		3.3
	4	357.1		6.6
C	1	364.4	3.2	
	2	365.7		4.5
	3	357.8		3.4
	4	355.6		5.6
D	1	363.1	1.9	
	2	357.1		4.1
	3	357.6		3.6
	4	356.5		4.7

<sup>1</sup> See Figure A4.

<sup>2</sup> All elevations (el) are in feet referenced to National Geodetic Vertical Datum (NGVD) (To convert feet to meters, multiply number of feet by 0.3048).

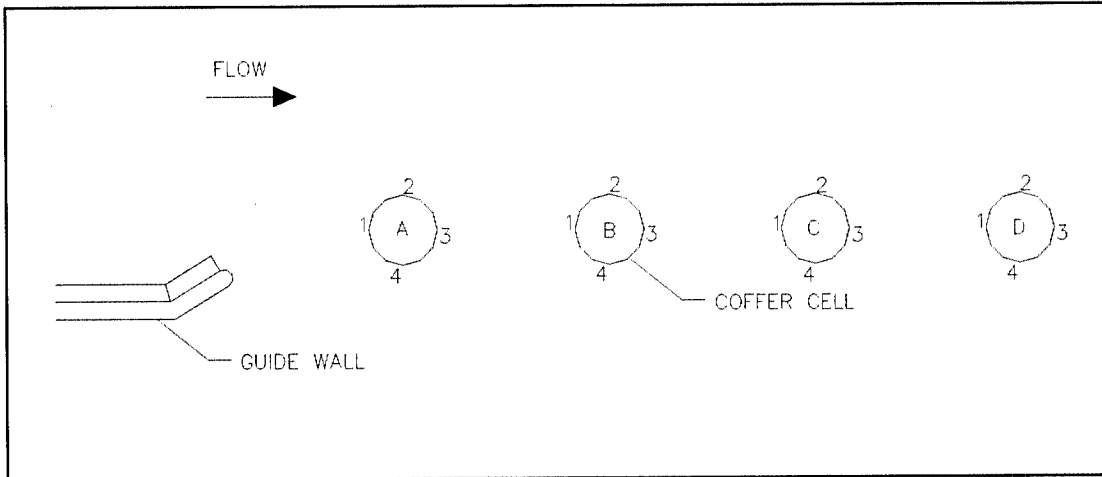

Figure A4. Velocities and current directions, construction flow 1, discharge 40,000 cfs, tailwater 341.5 ft

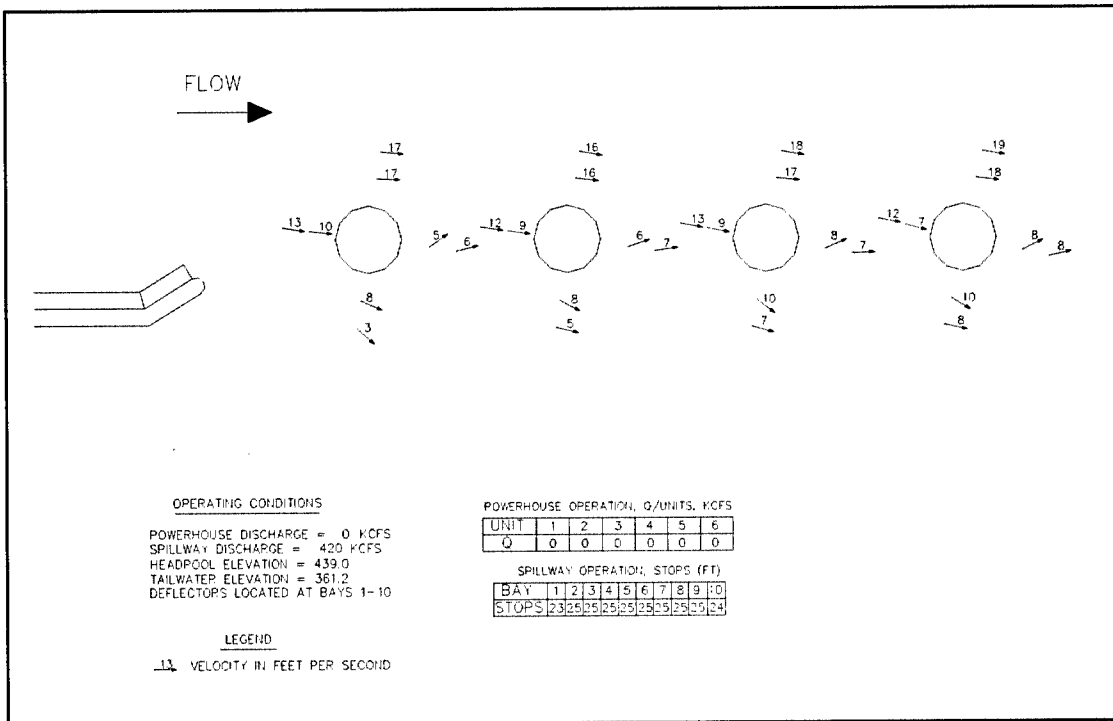

Figure A5. Velocities and current directions, coffer cell design velocities (surface velocities) discharge, 420,000 cfs, tailwater, 361.2 ft

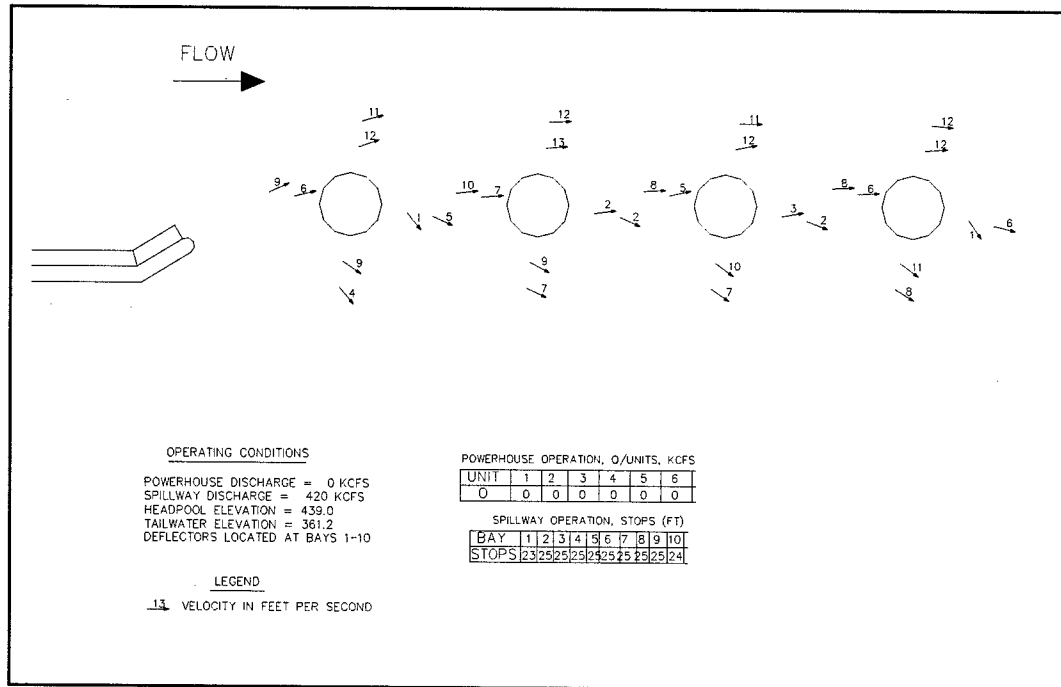
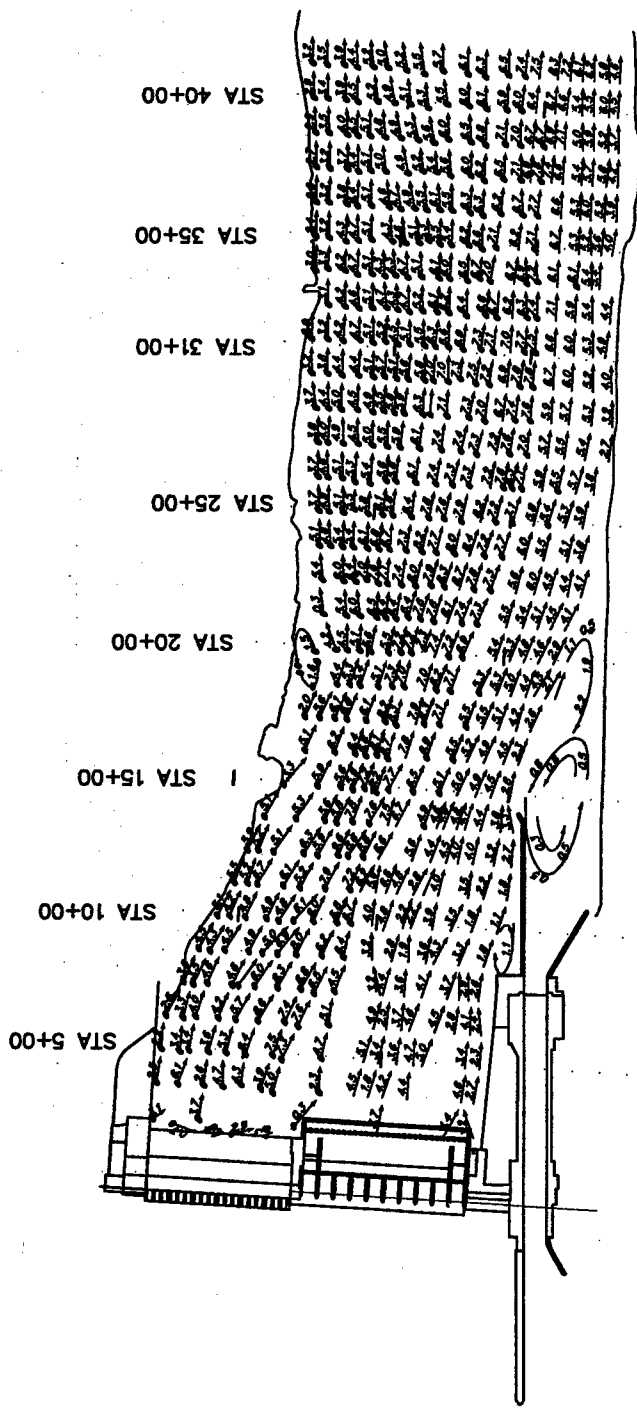

Figure A6. Velocities and current directions, coffer cell design velocities (bottom velocities) discharge, 420,000 cfs, tailwater, 361.2 ft



**OPERATING CONDITIONS**

POWERHOUSE DISCHARGE = 72.3 KCFS  
 SPILLWAY DISCHARGE = 30 KCFS  
 HEADPOOL ELEVATION = 439.0  
 TAILWATER ELEVATION = 346.5

**LEGEND**

$\frac{3.5}{-2.3}$  VELOCITY IN FEET PER SECOND (13.0 ft DRAFT)  
 VELOCITY IN FEET PER SECOND (7.0 ft DRAFT)  
 NOTE: VELOCITIES AND CURRENT DIRECTION  
 OBTAINED WITH FLOATS SUBMERGED TO  
 DRAFT OF 13.0 ft and 7.0 ft

**POWERHOUSE OPERATION, Q/UNITS, KCFS**

UNIT	1	2	3	4	5	6
Q	12.3	12.3	12.3	17.7	0	17.7

**SPILLWAY OPERATION, STOPS (FT)**

BAY	1	2	3	4	5	6	7	8	9	10
STOPS	1	2	2	1	2	2	2	2	2	1.5

**SCALES IN FEET**



**VELOCITIES AND  
 CURRENT DIRECTIONS**  
 NO DEFLECTORS  
 DISCHARGE: 102,300 CFS  
 TAILWATER: 346.5 FT

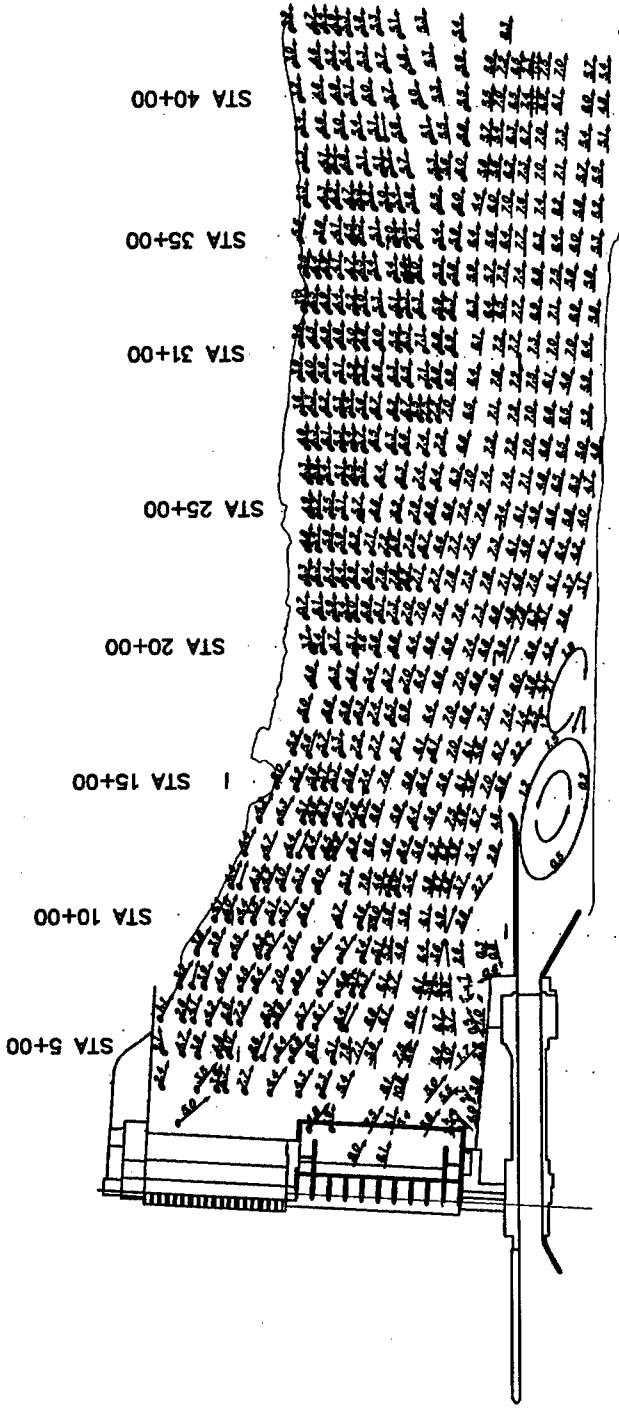

VELOCITIES AND  
CURRENT DIRECTIONS  
NO DEFLECTORS  
DISCHARGE: 117,300 CFS  
TAILWATER: 347.7 FT

POWERHOUSE OPERATION, Q/UNITS, KCFS

UNIT	1	2	3	4	5	6
Q	12.3	12.3	12.3	17.7	0	17.7

SPILLWAY OPERATION, STOPS (FT)

BAY	1	2	3	4	5	6	7	8	9	10
STOPS	1	2	3	3	4	4	3	3	2	1.5

SCALES IN FEET



OPERATING CONDITIONS

POWERHOUSE DISCHARGE = 72.3 KCFS  
SPILLWAY DISCHARGE = 45 KCFS  
HEADPOOL ELEVATION = 439.0  
TAILWATER ELEVATION = 347.7

LEGEND

— 1.5 — VELOCITY IN FEET PER SECOND (13.0 ft DRAFT)  
— 2.3 — VELOCITY IN FEET PER SECOND (7.0 ft DRAFT)

NOTE: VELOCITIES AND CURRENT DIRECTION  
OBTAINED WITH FLOATS SUBMERGED TO  
DRAFT OF 13.0 ft and 7.0 ft

Plate 2

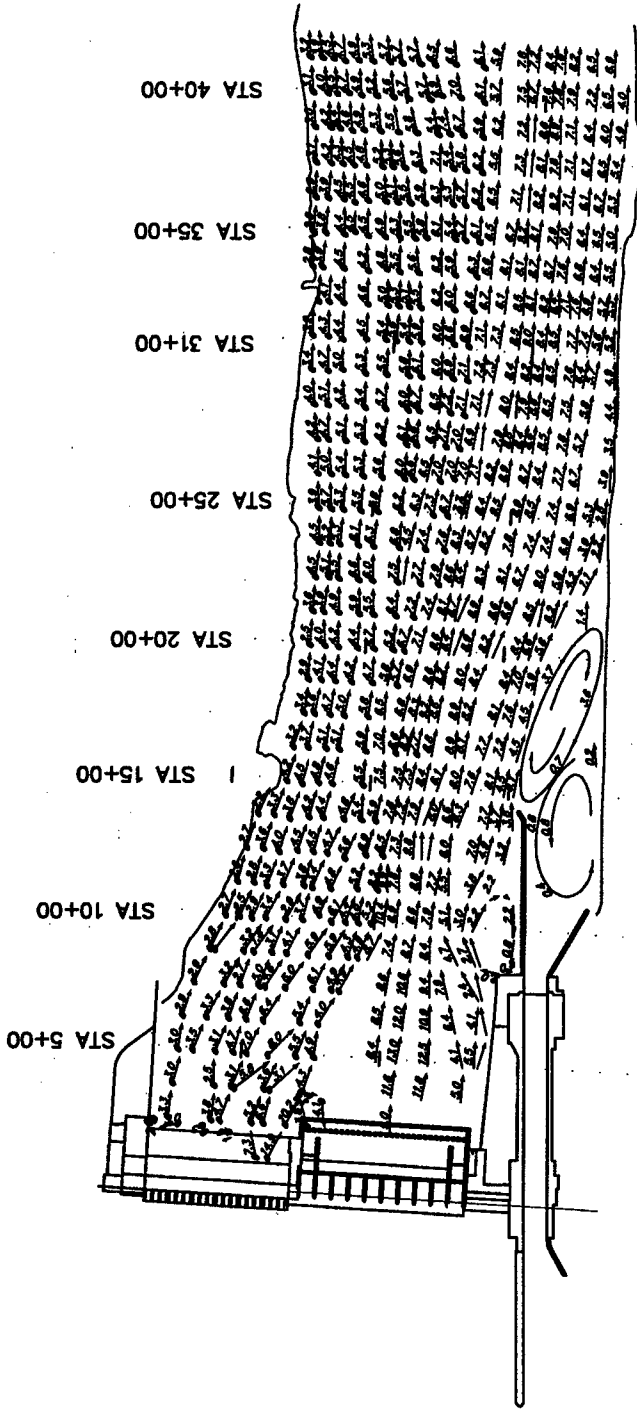

**OPERATING CONDITIONS**

POWERHOUSE DISCHARGE = 72.3 KCFS  
 SPILLWAY DISCHARGE = 55 KCFS  
 HEADPOOL ELEVATION = 439.0  
 TAILWATER ELEVATION = 348.3

**LEGEND**

VELOCITY IN FEET PER SECOND (13.0 ft DRAFT)  
 VELOCITY IN FEET PER SECOND (7.0 ft DRAFT)

NOTE : VELOCITIES AND CURRENT DIRECTION  
 OBTAINED WITH FLOATS SUBMERGED TO  
 DRAFT OF 13.0 ft and 7.0 ft

**POWERHOUSE OPERATION, Q/UNITS, KCFS**

UNIT	1	2	3	4	5	6
Q	12.3	12.3	12.3	17.7	0	17.7

**SPILLWAY OPERATION, STOPS (FT)**

BAY	1	2	3	4	5	6	7	8	9	10
STOPS	1	2	3	4	5	5	4	4	3	1.5

**SCALES IN FEET**



**VELOCITIES AND  
 CURRENT DIRECTIONS**  
 NO DEFLECTORS  
 DISCHARGE: 127,300 CFS  
 TAILWATER: 348.3 FT

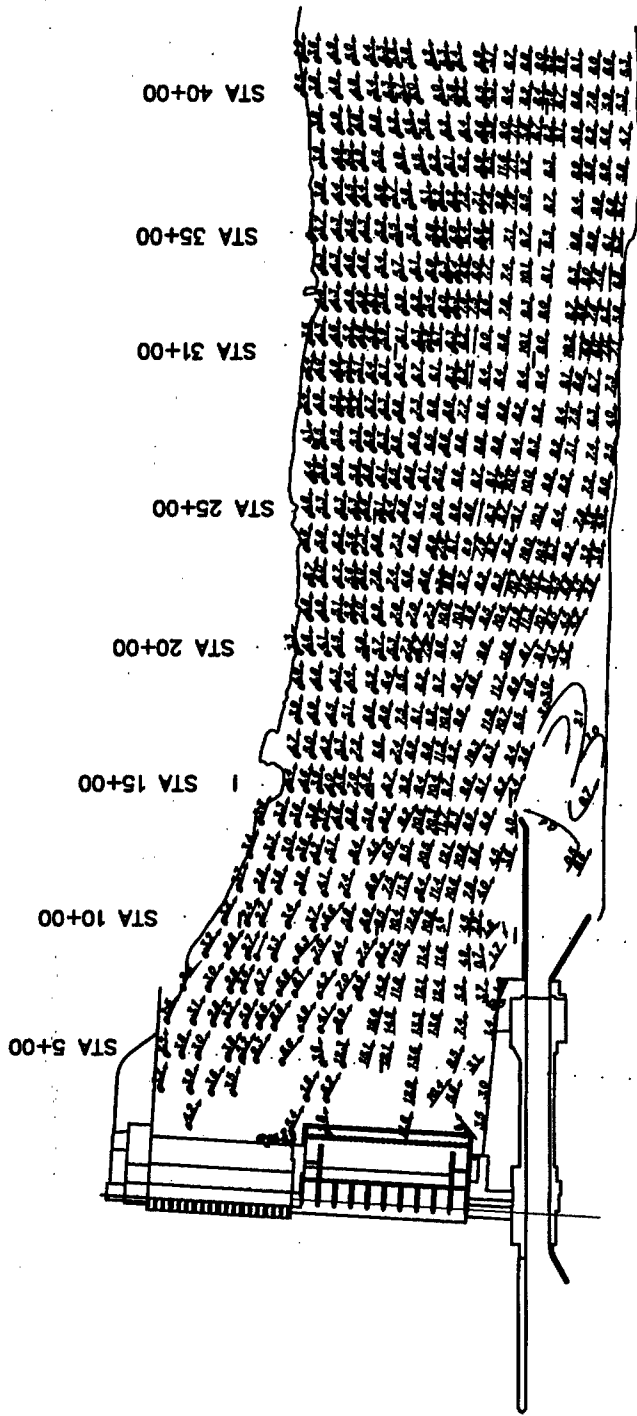

**VELOCITIES AND  
CURRENT DIRECTIONS**  
NO DEFLECTORS  
DISCHARGE: 147,300 CFS  
TAILWATER: 349.7 FT

**POWERHOUSE OPERATION, Q/UNITS, KCFS**

UNIT	1	2	3	4	5	6
Q	12.3	12.3	12.3	17.7	0	17.7

**SPILLWAY OPERATION, STOPS (FT)**

BAY	1	2	3	4	5	6	7	8	9	10
STOPS	2	3	5	6	7	6	6	5	3	5

**SCALES IN FEET**



**OPERATING CONDITIONS**

POWERHOUSE DISCHARGE = 72.3 KCFS  
 SPILLWAY DISCHARGE = 75 KCFS  
 HEADPOOL ELEVATION = 439.0  
 TAILWATER ELEVATION = 349.7

**LEGEND**

VELOCITY IN FEET PER SECOND (13.0 R DRAFT)  
 VELOCITY IN FEET PER SECOND (7.0 ft DRAFT)



**NOTE :**  
 VELOCITIES AND CURRENT DIRECTION  
 OBTAINED WITH FLOATS SUBMERGED TO  
 DRAFT OF 13.0 ft and 7.0 ft

Plate 4

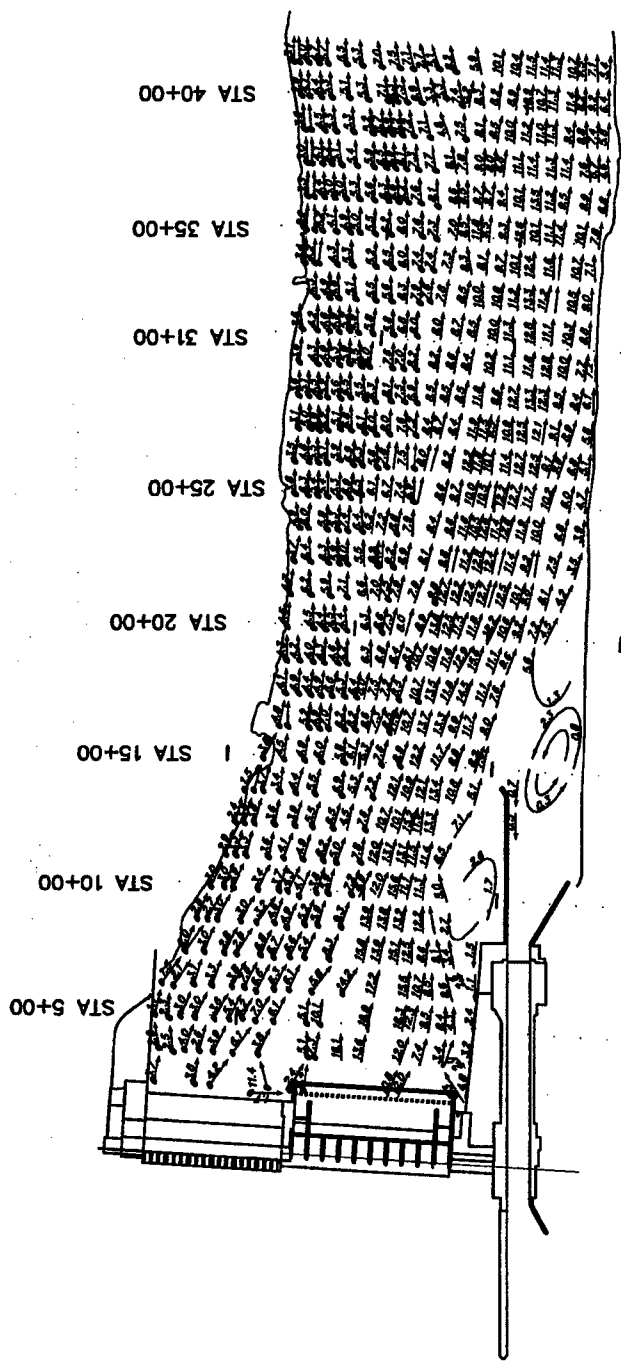

VELOCITIES AND  
CURRENT DIRECTIONS  
NO DEFLECTORS  
DISCHARGE: 172,300 CFS  
TAILWATER: 351.0 FT

POWERHOUSE OPERATION, Q/UNITS, KCFS

UNIT	1	2	3	4	5	6
Q	12.3	12.3	12.3	17.7	0	17.7

SPILLWAY OPERATION, STOPS (FT)

BAY	1	2	3	4	5	6	7	8	9	10
STOPS	2	4	7	9	9	7	6	4	2	

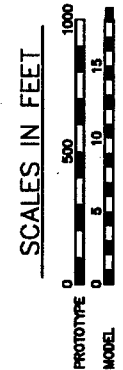

OPERATING CONDITIONS  
POWERHOUSE DISCHARGE = 72.3 KCFS  
SPILLWAY DISCHARGE = 100 KCFS  
HEADPOOL ELEVATION = 439.0  
TAILWATER ELEVATION = 351.0

LEGEND  
VELOCITY IN FEET PER SECOND (13.0 ft DRAFT)  
VELOCITY IN FEET PER SECOND (7.0 ft DRAFT)  
NOTE : VELOCITIES AND CURRENT DIRECTION  
OBTAINED WITH FLOATS SUBMERGED TO  
DRAFT OF 13.0 ft and 7.0 ft

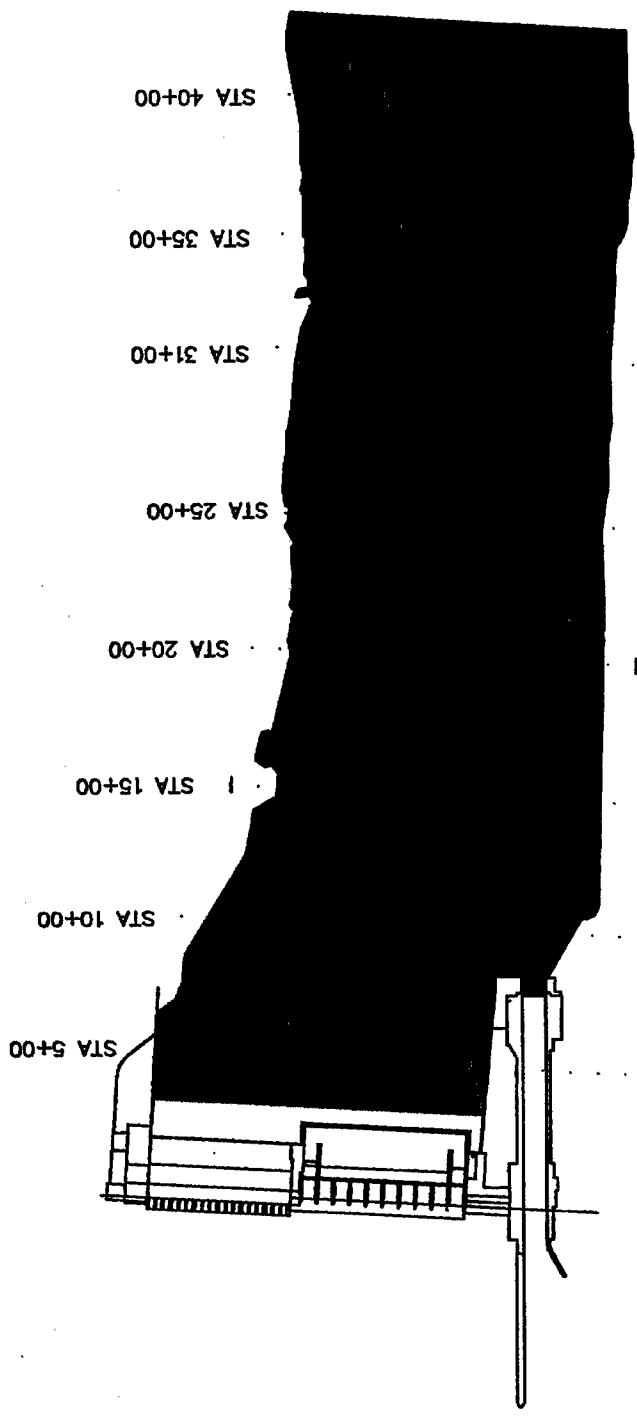

**OPERATING CONDITIONS**  
 POWERHOUSE DISCHARGE = 72.3 KCFS  
 SPILLWAY DISCHARGE = 30 KCFS  
 HEADPOOL ELEVATION = 439.0  
 TAILWATER ELEVATION = 346.5

**LEGEND**

0.0 - 2.5 fps
2.6 - 5.0 fps
5.1 - 7.5 fps
7.6 - 10.0 fps
10.1 - 12.5 fps
12.6 - 15.0 fps
> 15.1 fps

**POWERHOUSE OPERATION, Q/UNITS, KCFS**

UNIT	1	2	3	4	5	6
Q	12.3	12.3	12.3	17.7	0	17.7

**SPILLWAY OPERATION, STOPS (FT)**

BAY	1	2	3	4	5	6	7	8	9	10
STOPS	1	2	2	1	2	2	2	2	2	1.5

**ISOVEL PLOT**  
 NO DEFLECTORS  
 DISCHARGE: 102,300 CFS  
 TAILWATER: 346.5 FT



Plate 6

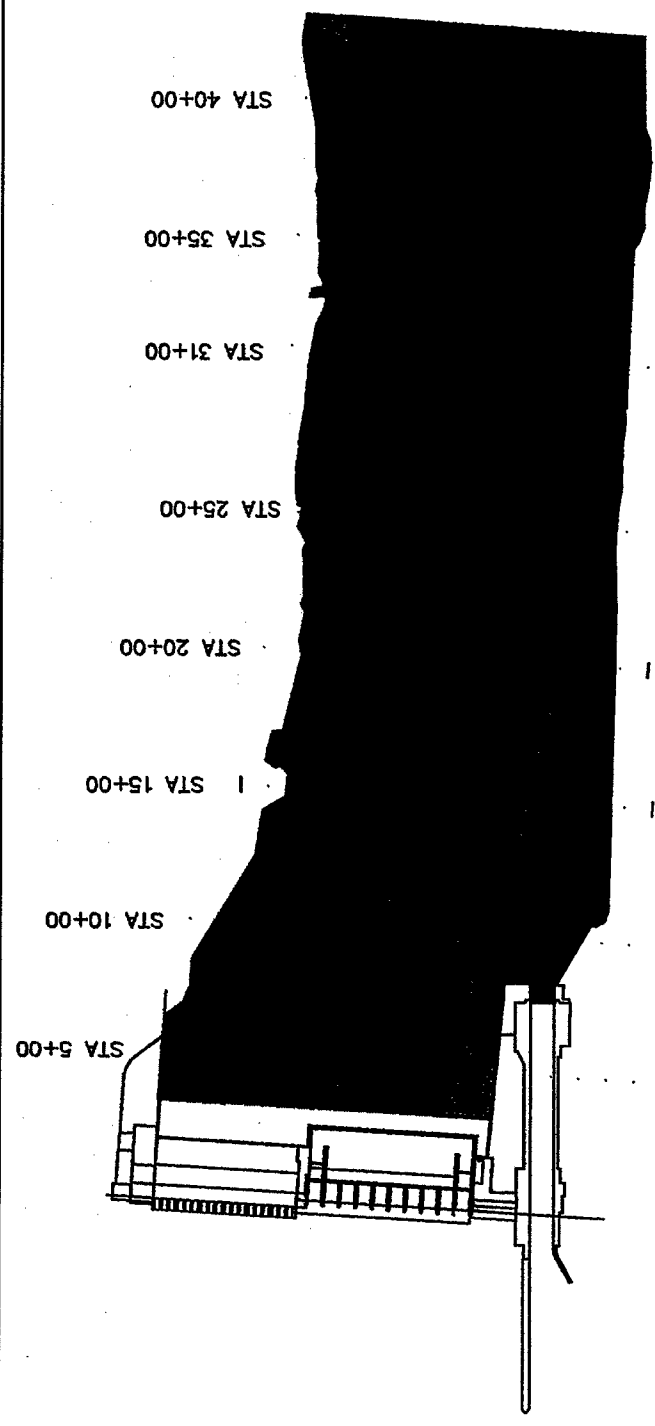

**OPERATING CONDITIONS**  
 POWERHOUSE DISCHARGE = 72.3 KCFS  
 SPILLWAY DISCHARGE = 45 KCFS  
 HEADPOOL ELEVATION = 439.0  
 TAILWATER ELEVATION = 347.7

**POWERHOUSE OPERATION, Q/UNITS, KCFS**

UNIT	1	2	3	4	5	6
Q	12.3	12.3	12.3	17.7	0	17.7

**SPILLWAY OPERATION, STOPS (FT)**

BAY	1	2	3	4	5	6	7	8	9	10
STOPS	1	2	3	3	4	4	3	3	2	1.5

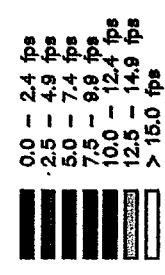

**ISOVEL PLOT**  
 NO DEFLECTORS  
 DISCHARGE: 117,300 CFS  
 TAILWATER: 347.7 FT

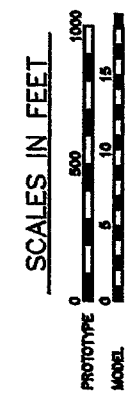

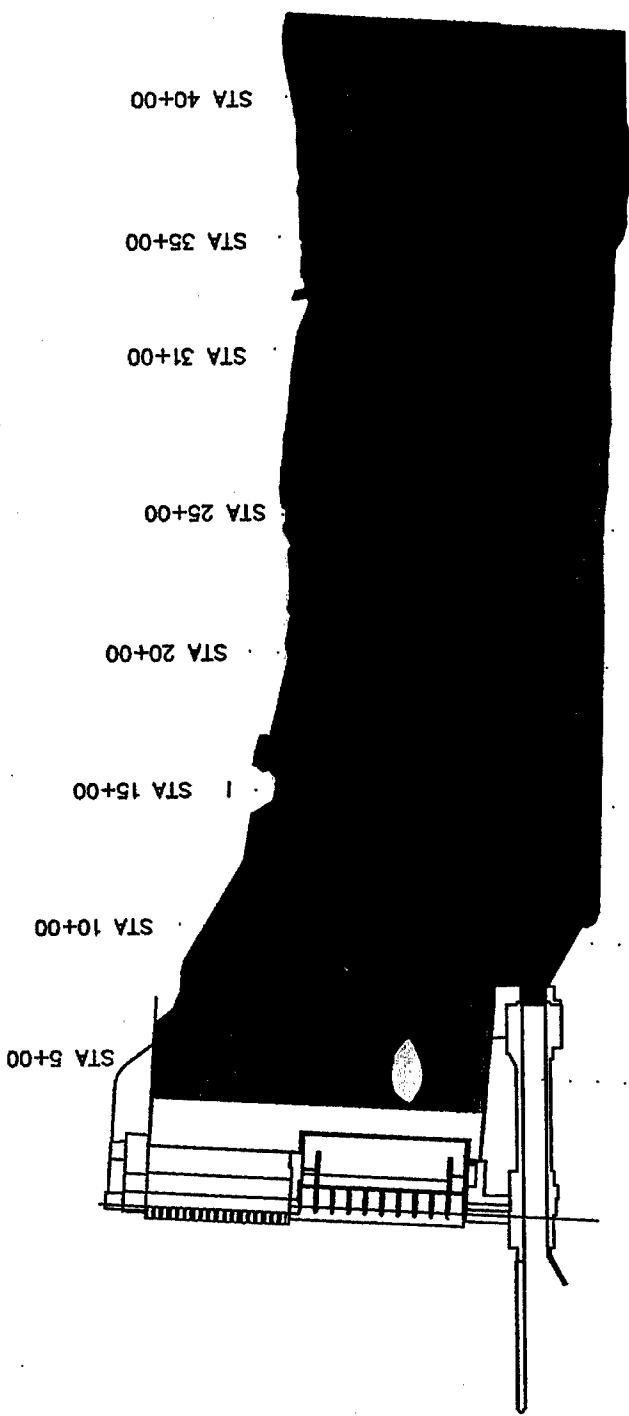

STA 5+00  
STA 10+00  
STA 15+00  
STA 20+00  
STA 25+00  
STA 31+00  
STA 35+00  
STA 40+00

**OPERATING CONDITIONS**

POWERHOUSE DISCHARGE = 72.3 KCFS  
 SPILLWAY DISCHARGE = 55 KCFS  
 HEADFOOL ELEVATION = 439.0  
 TAILWATER ELEVATION = 348.3

**POWERHOUSE OPERATION, Q/UNITS, KCFS**

UNIT	1	2	3	4	5	6
Q	12.3	12.3	12.3	17.7	0	17.7

**SPILLWAY OPERATION, STOPS (FT)**

BAY	1	2	3	4	5	6	7	8	9	10
STOPS	1	2	3	4	5	5	4	4	3	1.5

**LEGEND**

- 0.0 - 2.5 fps
- 2.6 - 5.0 fps
- 5.1 - 7.5 fps
- 7.6 - 10.0 fps
- 10.1 - 12.5 fps
- 12.6 - 15.0 fps
- > 15.1 fps

**ISOVEL PLOT**

NO DEFLECTORS  
 DISCHARGE: 127,300 CFS  
 TAILWATER: 348.3 FT

**SCALES IN FEET**



Plate 8

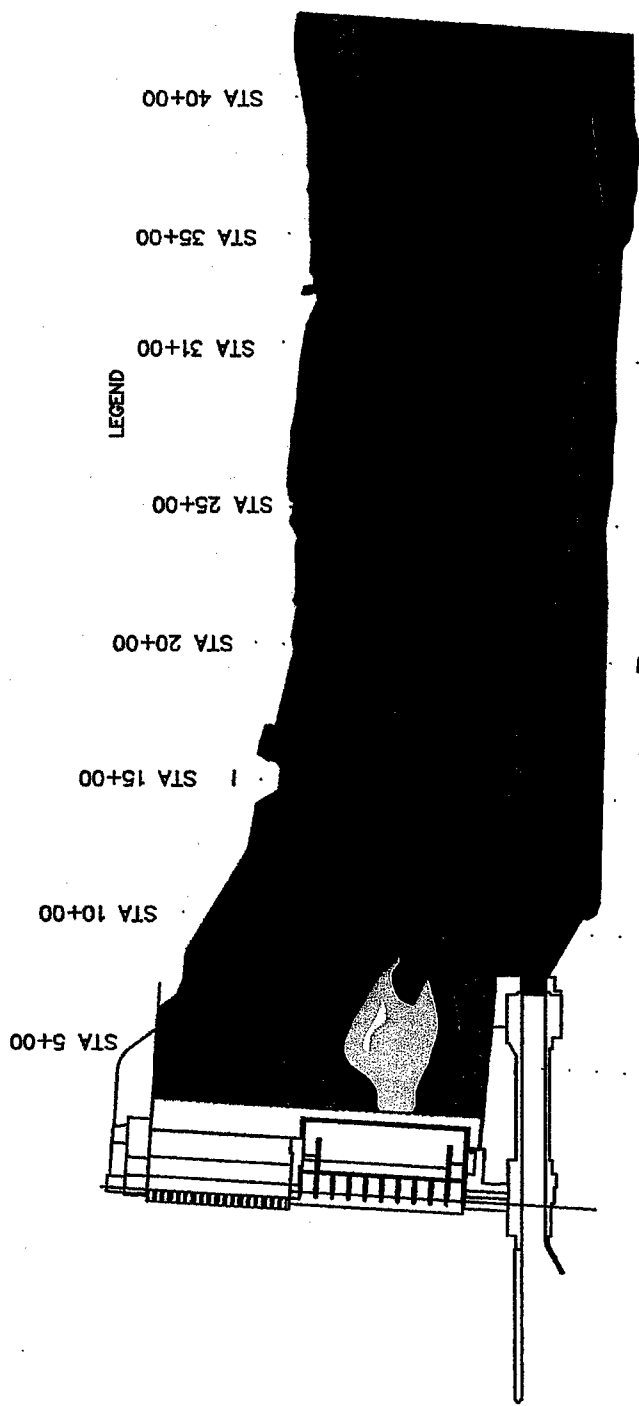

LEGEND

**OPERATING CONDITIONS**

POWERHOUSE DISCHARGE = 72.3 KCFS  
 SPILLWAY DISCHARGE = 75 KCFS  
 HEADPOOL ELEVATION = 439.0  
 TAILWATER ELEVATION = 349.7

**POWERHOUSE OPERATION, Q/UNITS, KCFS**

UNIT	1	2	3	4	5	6
Q	12.3	12.3	12.3	17.7	0	17.7

**SPILLWAY OPERATION, STOPS (FT)**

BAY	1	2	3	4	5	6	7	8	9	10
STOPS	2	3	5	6	7	8	6	5	3	1.5

**LEGEND**

- 0.0 - 2.4 fps
- 2.5 - 4.9 fps
- 5.0 - 7.4 fps
- 7.5 - 9.8 fps
- 10.0 - 12.4 fps
- 12.5 - 14.9 fps
- > 15.0 fps

**ISOVEL PLOT**

NO DEFLECTORS  
 DISCHARGE: 147,300 CFS  
 TAILWATER: 349.7 FT

**SCALES IN FEET**



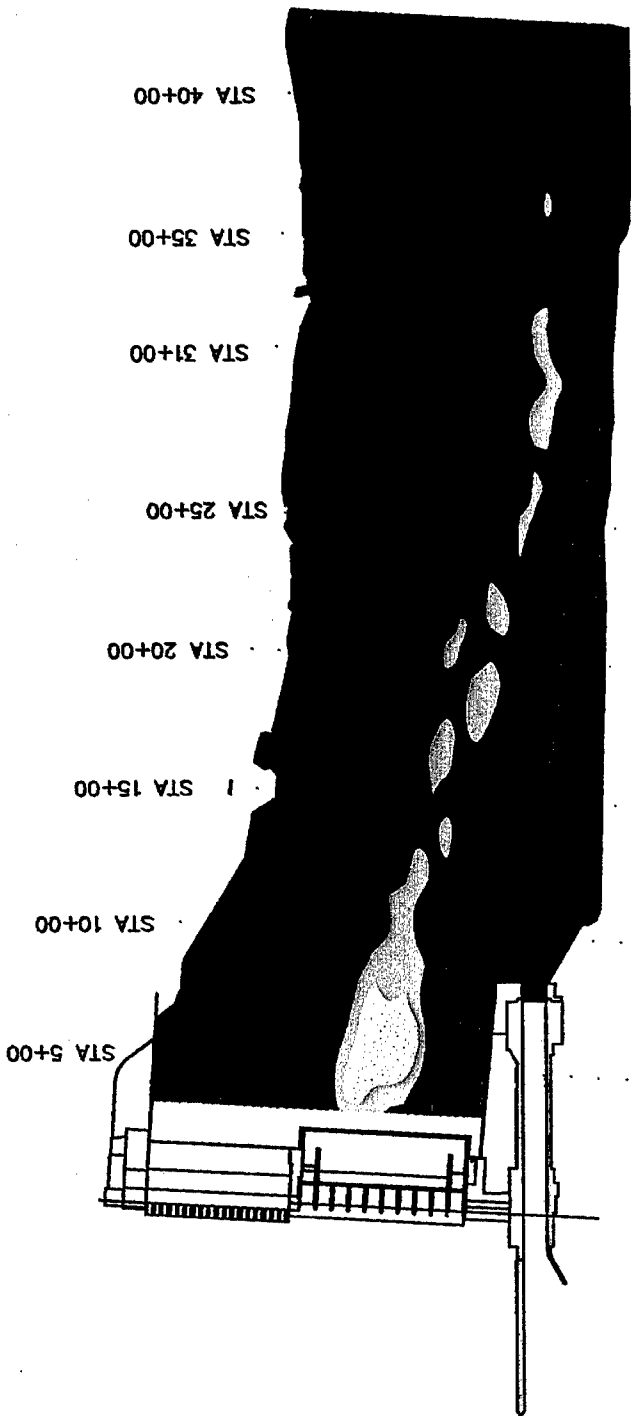

**ISOVEL PLOT**  
 NO DEFLECTORS  
 DISCHARGE: 172,300 CFS  
 TAILWATER: 351.0 FT

POWERHOUSE OPERATION, Q/UNITS, KCFS

UNIT	1	2	3	4	5	6
Q	12.3	12.3	12.3	17.7	0	17.7

SPILLWAY OPERATION, STOPS (FT)

BAY	1	2	3	4	5	6	7	8	9	10
STOPS	2	4	7	9	9	9	7	8	4	2

SCALES IN FEET



**OPERATING CONDITIONS**

POWERHOUSE DISCHARGE = 72.3 KCFS  
 SPILLWAY DISCHARGE = 100KCFS  
 HEADPOOL ELEVATION = 439.0  
 TAILWATER ELEVATION = 351.0

**LEGEND**

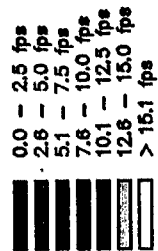
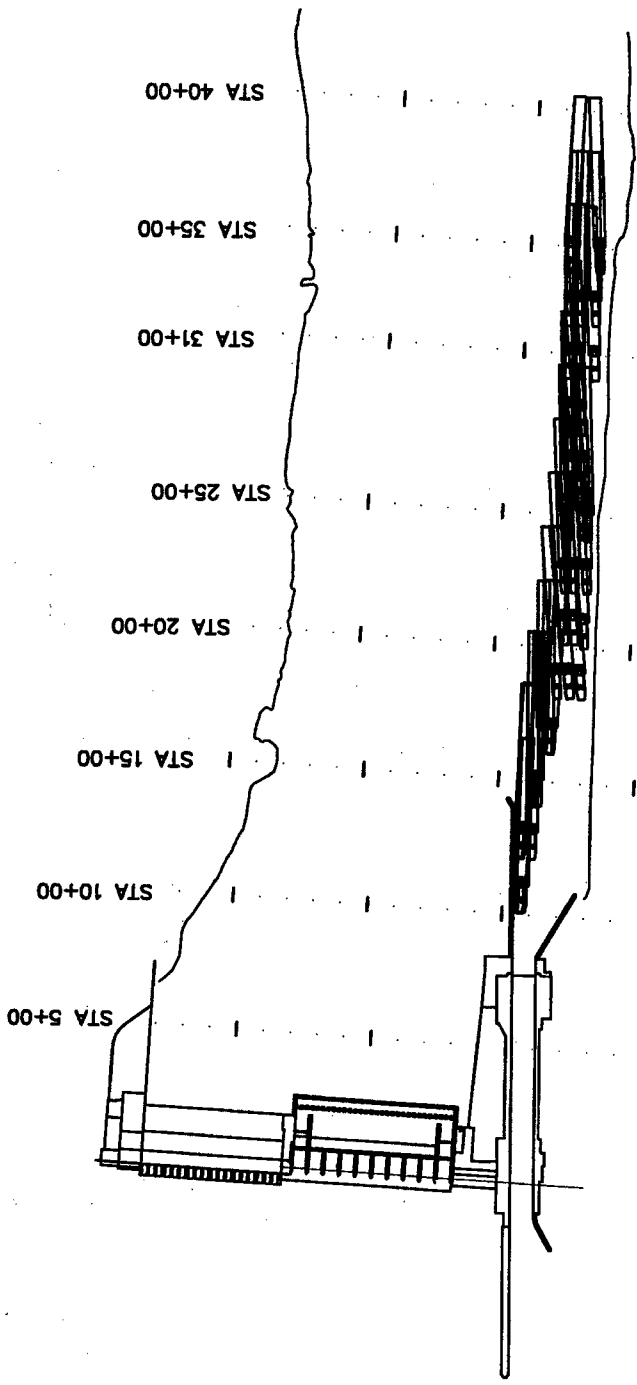

Plate 10



**TOW PATHS**  
**DOWNBOUND**  
**2-BARGE FLOTILLA**  
 (1 wide x 2 long)  
 DISCHARGE: 102,300 CFS  
 TAILWATER EL: 346.5 FT

POWERHOUSE OPERATION, Q/UNITS, KCFS

UNIT	1	2	3	4	5	6
Q	12.3	12.3	12.3	17.7	0	17.7

SPILLWAY OPERATION, STOPS (FT)

BAY	1	2	3	4	5	6	7	8	9	10
STOPS	1	2	2	1	2	2	2	2	2	1.5

**OPERATING CONDITIONS**

POWERHOUSE DISCHARGE = 72.3 KCFS  
 SPILLWAY DISCHARGE = 30 KCFS  
 HEADPOOL ELEVATION = 439.0  
 TAILWATER ELEVATION = 346.5

**LEGEND**

2-BARGE TOW: 1 WIDE X 2 LONG  
 42 ft WIDE X 548 ft LONG X 13 ft DRAFT  
 WITH 100-FT PUSHER BOAT

**SCALES IN FEET**



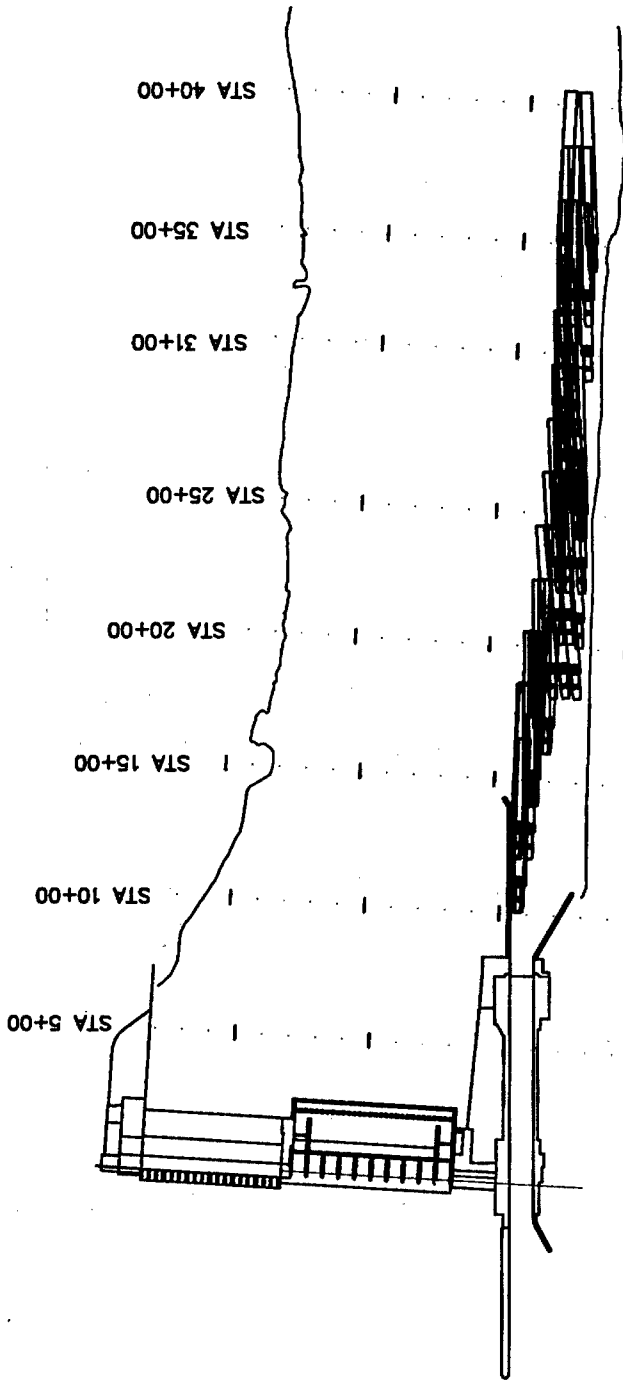

**OPERATING CONDITIONS**  
 POWERHOUSE DISCHARGE = 72.3 KCFS  
 SPILLWAY DISCHARGE = 30 KCFS  
 HEADPOOL ELEVATION = 439.0  
 TAILWATER ELEVATION = 346.5

**POWERHOUSE OPERATION, Q/UNITS, KCFS**

UNIT	1	2	3	4	5	6
Q	12.3	12.3	12.3	17.7	0	17.7

**SPILLWAY OPERATION, STOPS (FT)**

BAY	1	2	3	4	5	6	7	8	9	10
STOPS	1	2	2	2	1	2	2	2	2	3

**TOW PATHS  
 DOWNBOUND  
 2-BARGE FLOTILLA  
 (1 wide x 2 long)  
 DISCHARGE: 102,300 CFS  
 TAILWATER EL: 346.5 FT**

**LEGEND**

2-BARGE TOW: 1 WIDE X 2 LONG  
 42 ft WIDE X 548 ft LONG X 13 ft DRAFT  
 WITH 100-ft PUSHER BOAT

**SCALES IN FEET**



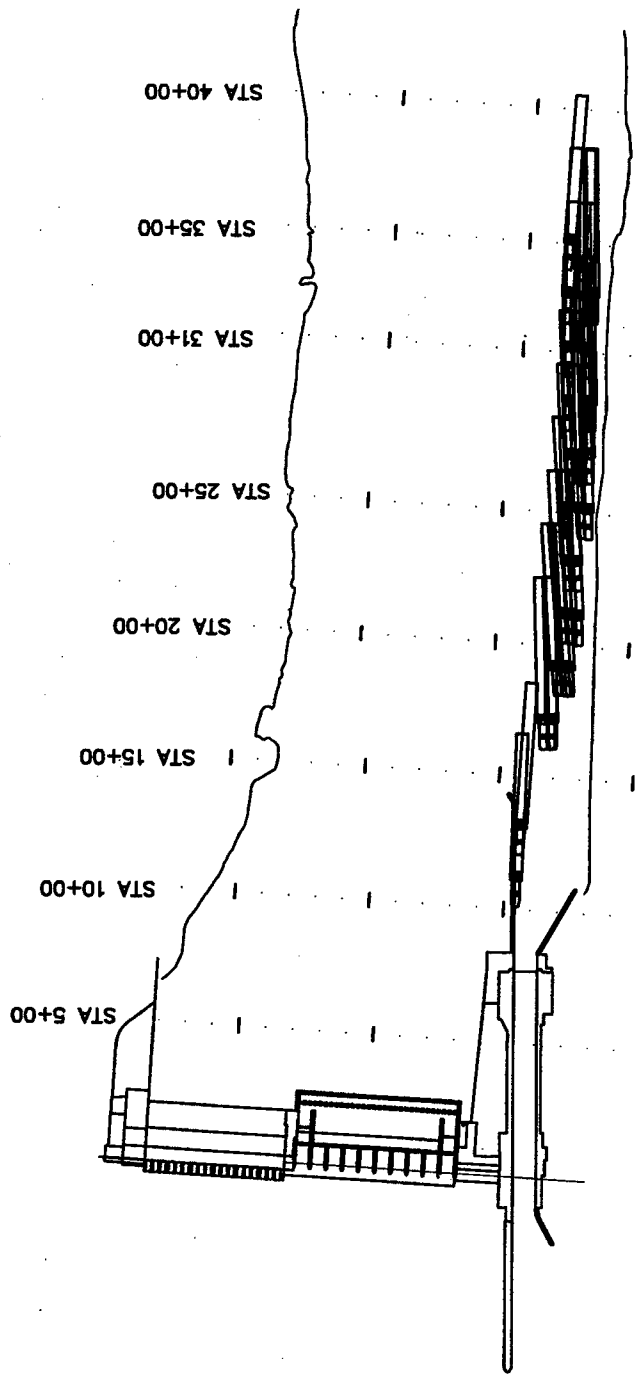

**OPERATING CONDITIONS**

POWERHOUSE DISCHARGE = 72.3 KCFS  
 SPILLWAY DISCHARGE = 55 KCFS  
 HEADPOOL ELEVATION = 439.0  
 TAILWATER ELEVATION = 348.3

**POWERHOUSE OPERATION, Q/UNITS, KCFS**

UNIT	1	2	3	4	5	6
Q	12.3	12.3	12.3	17.7	0	17.7

**SPILLWAY OPERATION, STOPS (FT)**

BAY	1	2	3	4	5	6	7	8	9	10
STOPS	1	2	3	4	5	5	4	4	3	5

**LEGEND**

2-BARGE TOW: 1 WIDE X 2 LONG  
 42 ft WIDE X 548 ft LONG X 13 ft DRAFT  
 WITH 100-ft PUSHER BOAT

**TOW PATHS**  
**DOWNBOUND**  
 NO DEFLECTORS  
 2-BARGE FLOTILLA  
 (1 wide x 2 long)  
 DISCHARGE: 127,300 CFS  
 TAILWATER EL: 348.3 FT

**SCALES IN FEET**



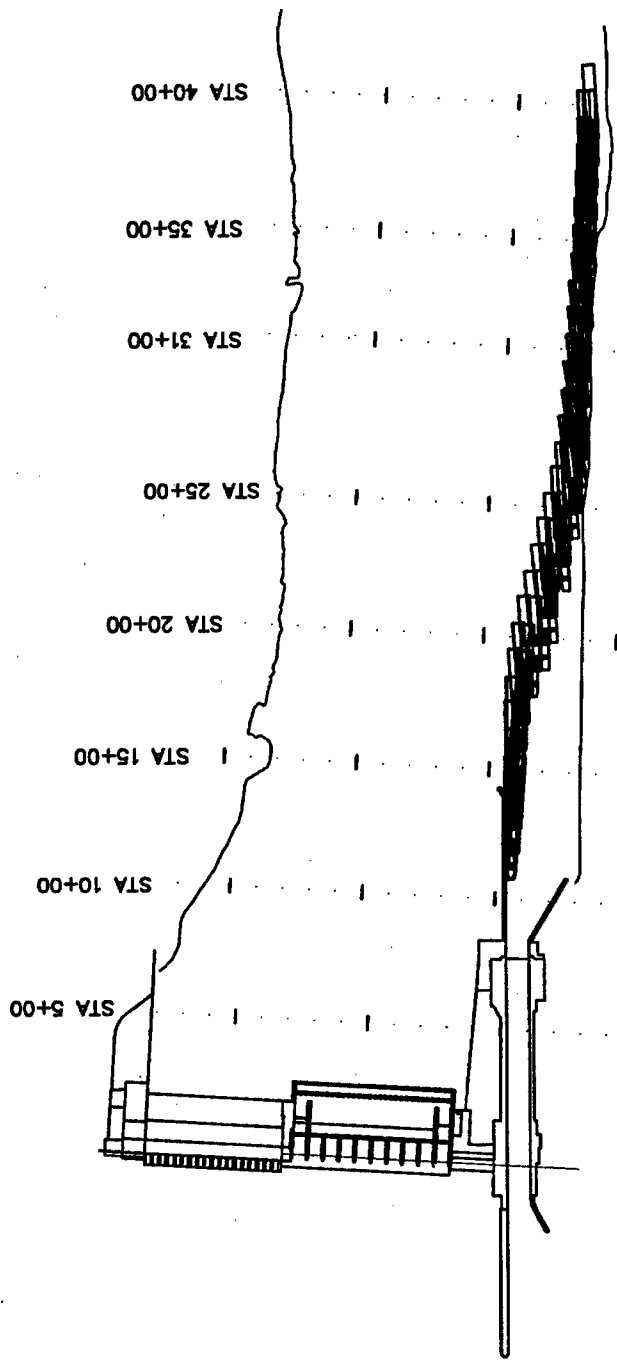

**OPERATING CONDITIONS**  
 POWERHOUSE DISCHARGE = 72.3 KCFS  
 SPILLWAY DISCHARGE = 100 KCFS  
 HEADPOOL ELEVATION = 439.0  
 TAILWATER ELEVATION = 351.0

**POWERHOUSE OPERATION, Q/UNITS, KCFS**

UNIT	1	2	3	4	5	6
Q	12.3	12.3	12.3	17.7	0	17.7

**SPILLWAY OPERATION, STOPS (FT)**

BAY	1	2	3	4	5	6	7	8	9	10
STOPS	2	4	7	9	9	9	7	6	4	2

**TOW PATHS**  
**DOWNBOUND**  
 NO DEFLECTORS  
 1-BARGE FLOTILLA  
 (1 wide x 1 long)  
 DISCHARGE: 172,300 CFS  
 TAILWATER EL: 351.0 FT

**LEGEND**

1-BARGE TOW: 1 WIDE X 1 LONG  
 42 ft WIDE X 274 ft LONG X 13 ft DRAFT  
 WITH 100-ft PUSHER BOAT

**SCALES IN FEET**



Plate 14

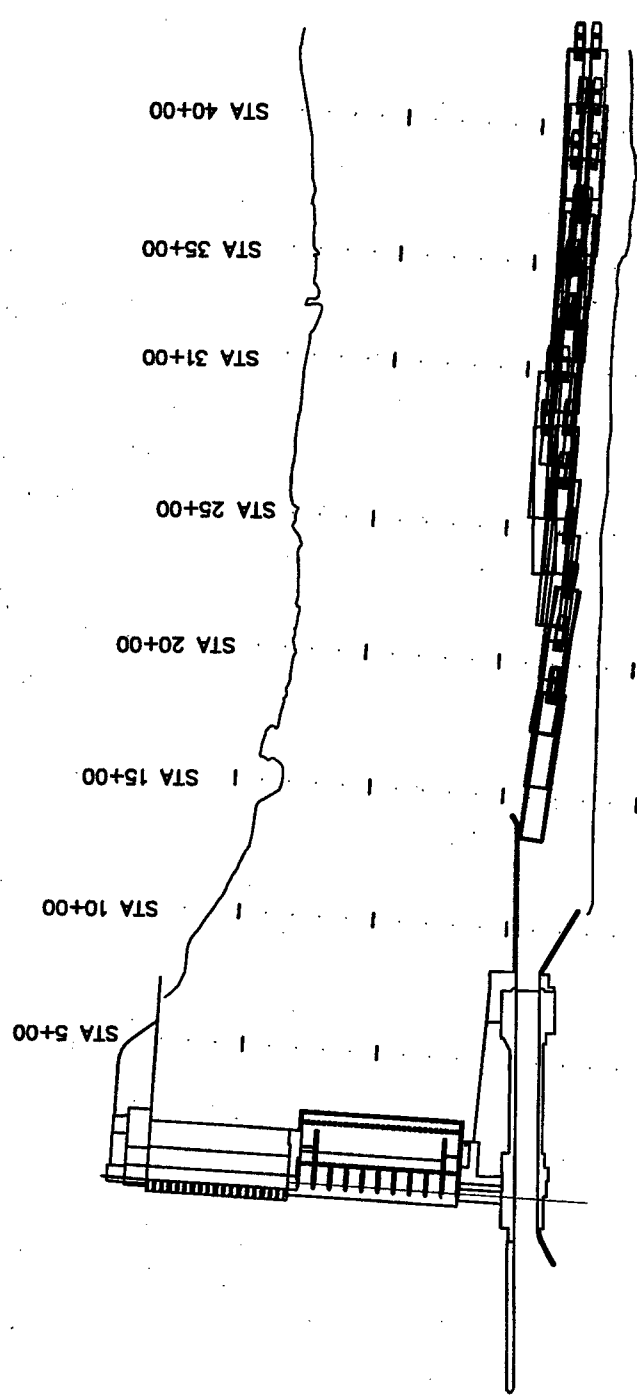

**OPERATING CONDITIONS**

POWERHOUSE DISCHARGE = 72.3 KCFS  
 SPILLWAY DISCHARGE = 30 KCFS  
 HEADPOOL ELEVATION = 439.0  
 TAILWATER ELEVATION = 346.5

**POWERHOUSE OPERATION, Q/UNITS, KCFS**

UNIT	1	2	3	4	5	6
Q	12.3	12.3	12.3	17.7	0	17.7

**SPILLWAY OPERATION, STOPS (FT)**

BAY	1	2	3	4	5	6	7	8	9	10
STOPS	1	2	2	2	1	2	2	2	2	1.5

**LEGEND**

4-BARGE TOW: 2 WIDE X 2 LONG  
 84 ft WIDE X 548 ft LONG X 13 ft DRAFT  
 WITH 100-ft PUSHER BOAT

**TOW PATHS  
 UPBOUND**  
 NO DEFLECTORS  
 4-BARGE FLOTILLA  
 (2 wide x 2 long)  
 DISCHARGE: 102,300 CFS  
 TAILWATER EL: 346.5 FT

**SCALES IN FEET**



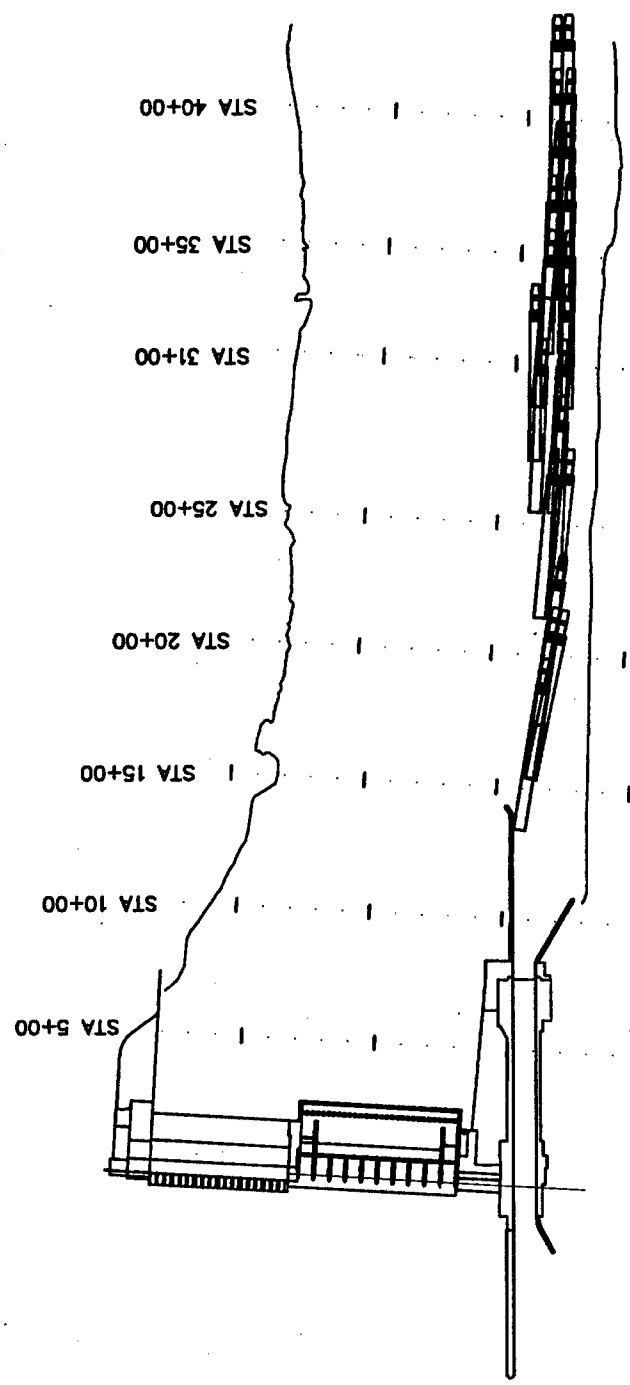

POWERHOUSE OPERATION, Q/UNITS, KCFS

UNIT	1	2	3	4	5	6
Q	12.3	12.3	12.3	17.7	0	17.7

SPILLWAY OPERATION, STOPS (FT)

BAY	1	2	3	4	5	6	7	8	9	10
STOPS	1	2	2	2	1	2	2	2	2	1.5

**OPERATING CONDITIONS**  
 POWERHOUSE DISCHARGE = 72.3 KCFS  
 SPILLWAY DISCHARGE = 30 KCFS  
 HEADPOOL ELEVATION = 439.0  
 TAILWATER ELEVATION = 346.5

**TOW PATHS  
 UPBOUND**  
 NO DEFLECTORS  
 2-BARGE FLOTILLA  
 (1 wide x 2 long)  
 DISCHARGE: 102,300 CFS  
 TAILWATER EL: 346.5 FT

**LEGEND**

2-BARGE TOW: 1 WIDE X 2 LONG  
 42 ft WIDE X 548 ft LONG X 13 ft DRAFT  
 WITH 100-ft PUSHER BOAT



Plate 16

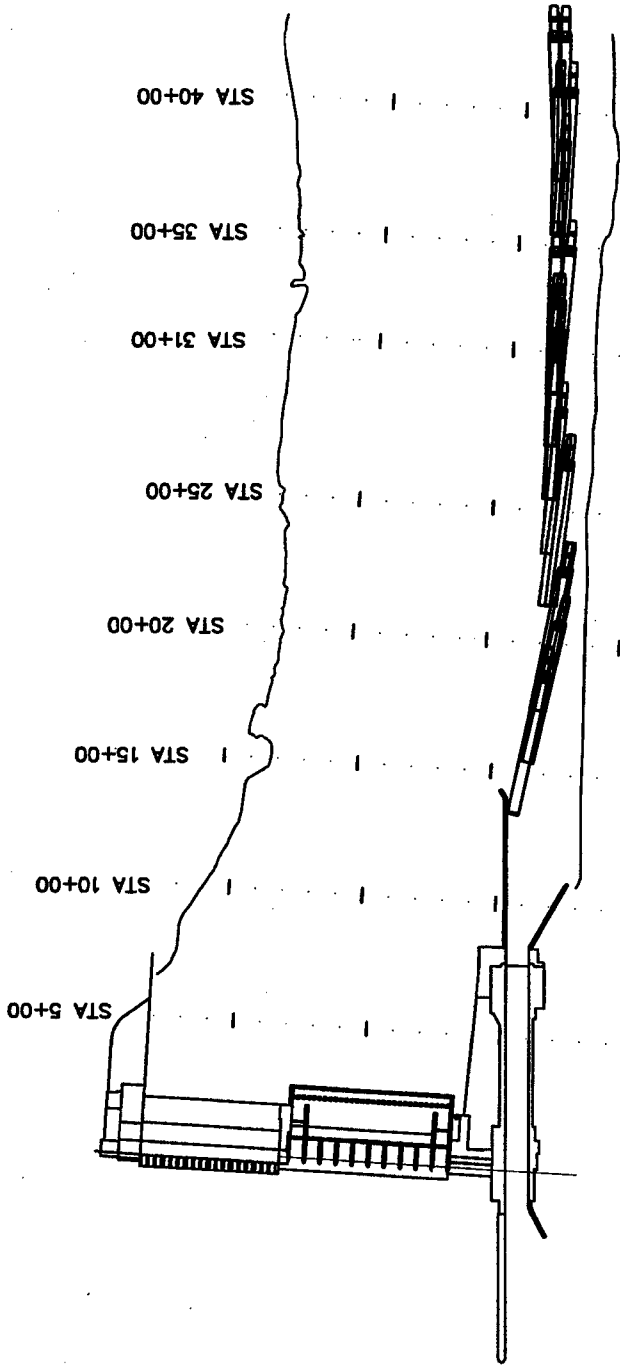

**OPERATING CONDITIONS**

POWERHOUSE DISCHARGE = 72.3 KCFS  
 SPILLWAY DISCHARGE = 55 KCFS  
 HEADPOOL ELEVATION = 439.0  
 TAILWATER ELEVATION = 348.3

**POWERHOUSE OPERATION, Q/UNITS, KCFS**

UNIT	1	2	3	4	5	6
Q	12.3	12.3	12.3	17.7	0	17.7

**SPILLWAY OPERATION, STOPS (FT)**

BAY	1	2	3	4	5	6	7	8	9	10
STOPS	1	2	3	4	5	4	3	4	3	1.5

**LEGEND**

2-BARGE TOW: 1 WIDE X 2 LONG  
 42 ft WIDE X 548 ft LONG X 13 ft DRAFT  
 WITH 100-ft PUSHER BOAT

TOW PATHS  
 UPBOUND  
 NO DEFLECTORS  
 2-BARGE FLOTILLA  
 (1 wide x 2 long)  
 DISCHARGE: 127,300 CFS  
 TAILWATER EL: 348.3 FT

**SCALES IN FEET**



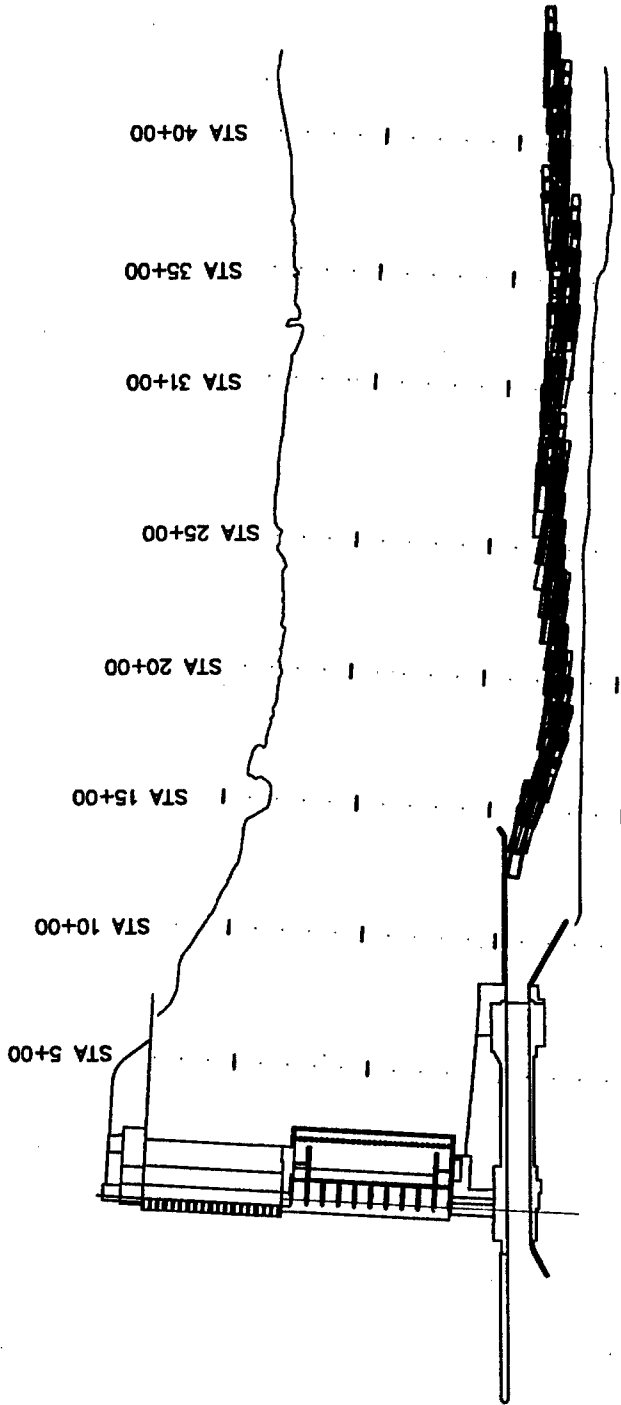

**POWERHOUSE OPERATION, Q/UNITS, KCFS**

UNIT	1	2	3	4	5	6
Q	12.3	12.3	12.3	17.7	0	17.7

**SPILLWAY OPERATION, STOPS (FT)**

BAY	1	2	3	4	5	6	7	8	9	10
STOPS	2	4	7	9	9	9	7	6	4	2

**OPERATING CONDITIONS**  
 POWERHOUSE DISCHARGE = 72.3 KCFS  
 SPILLWAY DISCHARGE = 100 KCFS  
 HEADPOOL ELEVATION = 439.0  
 TAILWATER ELEVATION = 351.0

**TOW PATHS**  
 UPBOUND  
 NO DEFLECTORS  
 1-BARGE FLOTILLA  
 (1 wide x 1 long)  
 DISCHARGE: 172,300 CFS  
 TAILWATER EL: 351.0 FT

**LEGEND**

1-BARGE TOW: 1 WIDE X 1 LONG  
 42 ft WIDE X 274 ft LONG X 13 ft DRAFT  
 WITH 100-ft PUSHER BOAT

**SCALES IN FEET**



Plate 18

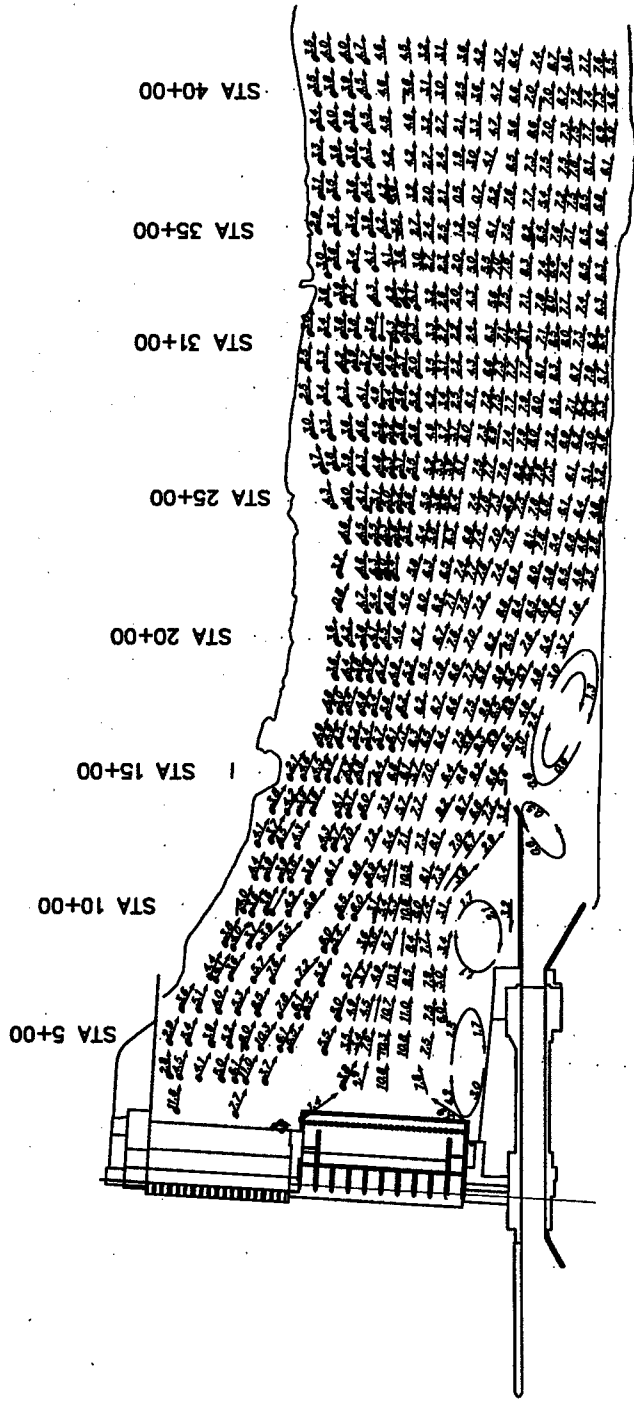

**OPERATING CONDITIONS**

POWERHOUSE DISCHARGE = 72.3 KCFS  
 SPILLWAY DISCHARGE = 30 KCFS  
 HEADPOOL ELEVATION = 439.0  
 TAILWATER ELEVATION = 346.5  
 DEFLECTORS LOCATED AT BAYS 4-7

**POWERHOUSE OPERATION, Q/UNITS, KCFS**

UNIT	1	2	3	4	5	6
Q	12.3	12.3	12.3	17.7	0	17.7

**SPILLWAY OPERATION, STOPS (FT)**

BAY	1	2	3	4	5	6	7	8	9	10
STOPS	1	3	0	2	2	2	2	0	4	5

**LEGEND**

VELOCITY IN FEET PER SECOND (13.0 ft DRAFT)  
 VELOCITY IN FEET PER SECOND (7.0 ft DRAFT)

NOTE : VELOCITIES AND CURRENT DIRECTION  
 OBTAINED WITH FLOATS SUBMERGED TO  
 DRAFT OF 13.0 ft and 7.0 ft

**VELOCITIES AND  
 CURRENT DIRECTIONS  
 4 DEFLECTORS**  
 DISCHARGE: 102,300 CFS  
 TAILWATER: 346.5 FT

**SCALES IN FEET**



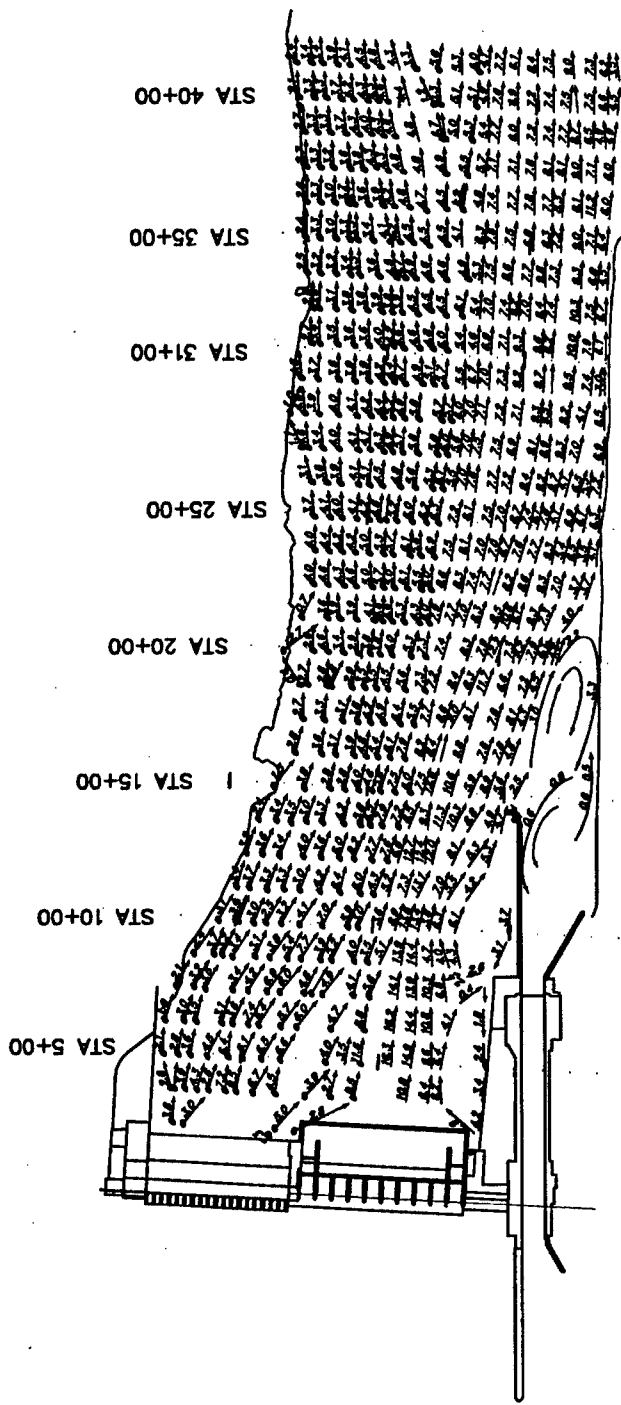

Plate 20

**OPERATING CONDITIONS**

POWERHOUSE DISCHARGE = 72.3 KCFS  
 SPILLWAY DISCHARGE = 45 KCFS  
 HEADPOOL ELEVATION = 439.0  
 TAILWATER ELEVATION = 347.7  
 DEFLECTORS LOCATED AT BAYS 4-7

**LEGEND**

$\frac{3.2}{2.1}$  VELOCITY IN FEET PER SECOND (13.0 ft DRAFT)  
 $\frac{3.2}{2.1}$  VELOCITY IN FEET PER SECOND (7.0 ft DRAFT)  
 NOTE : VELOCITIES AND CURRENT DIRECTION  
 OBTAINED WITH FLOATS SUBMERGED TO  
 DRAFT OF 13.0 ft and 7.0 ft

**POWERHOUSE OPERATION, Q/UNITS, KCFS**

UNIT	1	2	3	4	5	6
Q	12.3	12.3	12.3	17.7	0	17.7

**SPILLWAY OPERATION, STOPS (FT)**

BAY	1	2	3	4	5	6	7	8	9	10
STOPS	2	5	0	3	3	3	3	0	5	2

**SCALES IN FEET**



**VELOCITIES AND  
 CURRENT DIRECTIONS**  
 4 DEFLECTORS  
 DISCHARGE: 117,300 CFS  
 TAILWATER: 347.7 FT

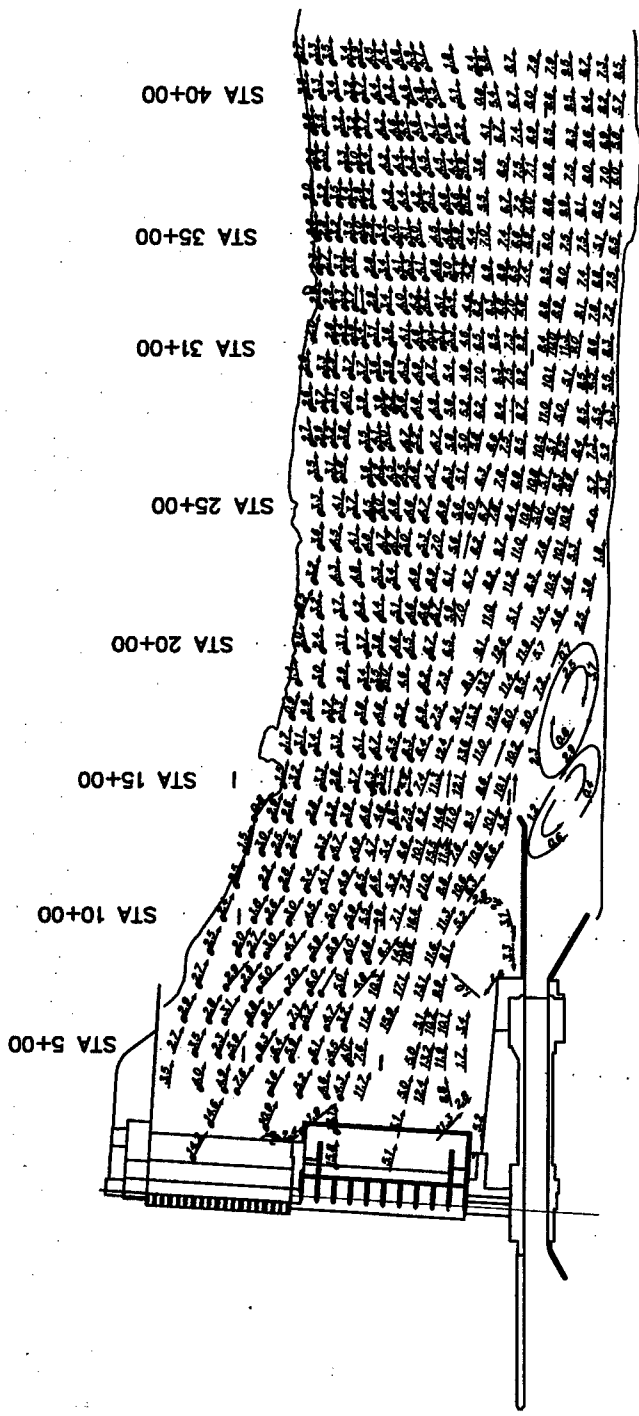

**VELOCITIES AND  
CURRENT DIRECTIONS**  
4 DEFLECTORS  
DISCHARGE: 127,300 CFS  
TAILWATER: 348.3 FT

POWERHOUSE OPERATION, Q/UNITS, KCFS

UNIT	1	2	3	4	5	6
Q	12.3	12.3	12.3	17.7	0	17.7

SPILLWAY OPERATION, STOPS (FT)

BAY	1	2	3	4	5	6	7	8	9	10
STOPS	2	5	0	4	4	4	4	4	0	6.5

**OPERATING CONDITIONS**  
POWERHOUSE DISCHARGE = 72.3 KCFS  
SPILLWAY DISCHARGE = 55 KCFS  
HEADPOOL ELEVATION = 439.0  
TAILWATER ELEVATION = 348.3  
DEFLECTORS LOCATED AT BAYS 4-7

**SCALES IN FEET**



**LEGEND**

VELOCITY IN FEET PER SECOND (13.0 ft DRAFT)  
VELOCITY IN FEET PER SECOND (7.0 ft DRAFT)  
NOTE : VELOCITIES AND CURRENT DIRECTION  
OBTAINED WITH FLOATS SUBMERGED TO  
DRAFT OF 13.0 ft and 7.0 ft



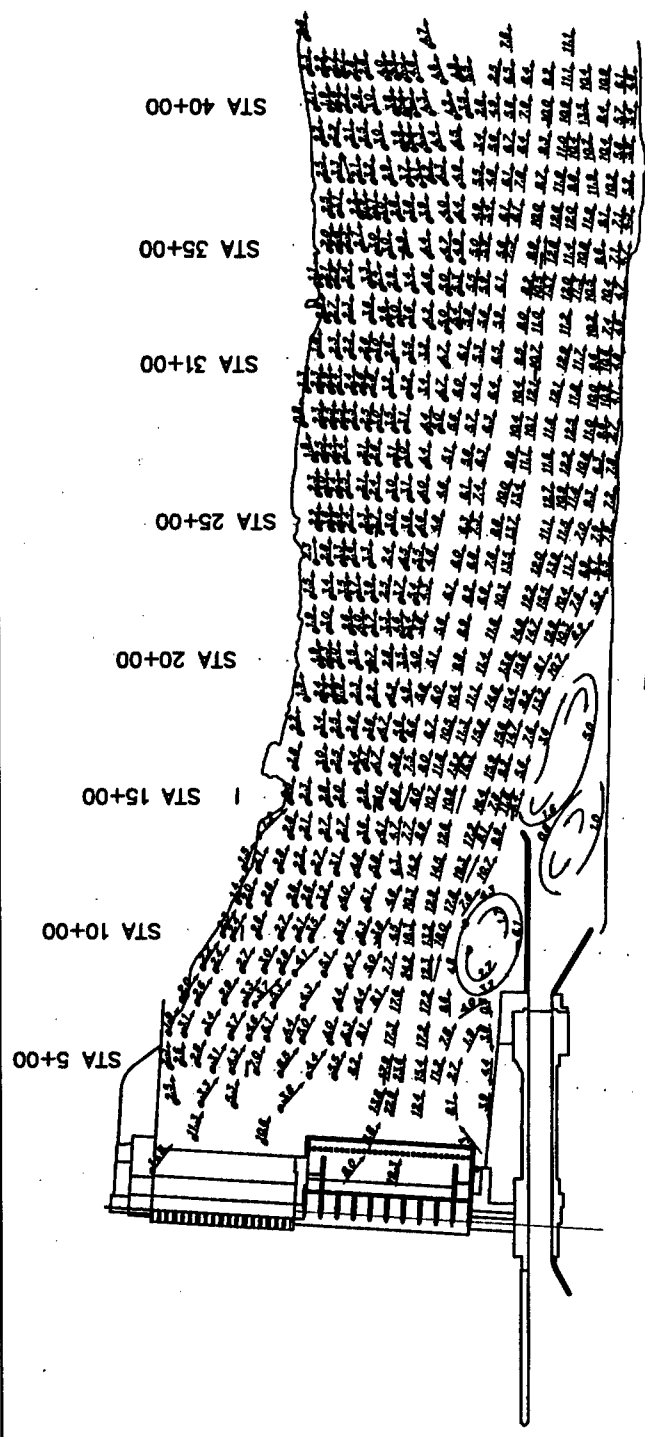

VELOCITIES AND  
CURRENT DIRECTIONS  
4 DEFLECTORS  
DISCHARGE: 147,300 CFS  
TAILWATER: 349.7 FT

POWERHOUSE OPERATION, Q/UNITS, KCFS

UNIT	1	2	3	4	5	6
Q	12.3	12.3	12.3	17.7	0	17.7

SPILLWAY OPERATION, STOPS (FT)

BAY	1	2	3	4	5	6	7	8	9	10
STOPS	3	8	0	5	6	6	5	0	8	3

SCALES IN FEET



OPERATING CONDITIONS

POWERHOUSE DISCHARGE = 72.3 KCFS  
SPILLWAY DISCHARGE = 75 KCFS  
HEADPOOL ELEVATION = 439.0  
TAILWATER ELEVATION = 349.7  
DEFLECTORS LOCATED AT BAYS 4-7

LEGEND

VELOCITY IN FEET PER SECOND (13.0 ft DRAFT)  
VELOCITY IN FEET PER SECOND (7.0 ft DRAFT)

NOTE : VELOCITIES AND CURRENT DIRECTION  
OBTAINED WITH FLOATS SUBMERGED TO  
DRAFT OF 13.0 ft and 7.0 ft

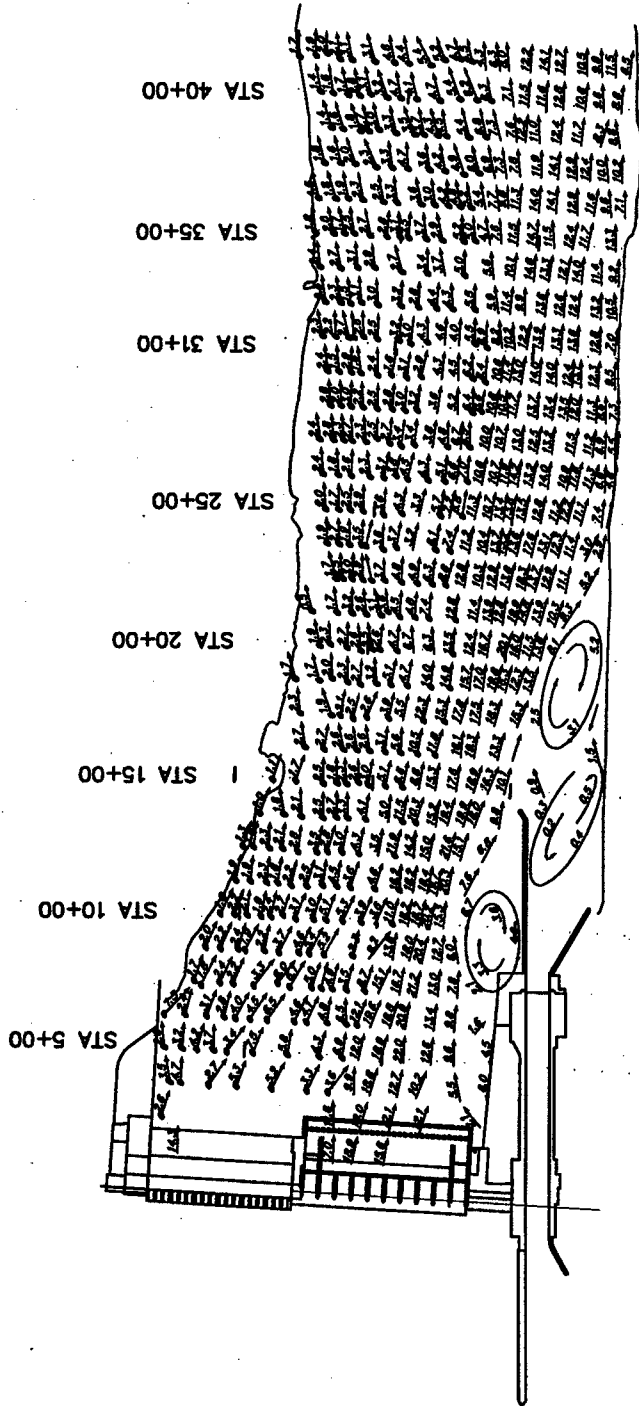

**OPERATING CONDITIONS**

POWERHOUSE DISCHARGE = 72.3 KCFS  
 SPILLWAY DISCHARGE = 100 KCFS  
 HEADPOOL ELEVATION = 439.0  
 TAILWATER ELEVATION = 351.0  
 DEFLECTORS LOCATED AT BAYS 4-7

**LEGEND**

— 3.5 — VELOCITY IN FEET PER SECOND (13.0 ft DRAFT)  
 — 4.2.3 — VELOCITY IN FEET PER SECOND (7.0 ft DRAFT)  
 NOTE : VELOCITIES AND CURRENT DIRECTION  
 OBTAINED WITH FLOATS SUBMERGED TO  
 DRAFT OF 13.0 ft and 7.0 ft

**POWERHOUSE OPERATION, Q/UNITS, KCFS**

UNIT	1	2	3	4	5	6
Q	12.3	12.3	12.3	17.7	0	17.7

**SPILLWAY OPERATION, STOPS (FT)**

BAY	1	2	3	4	5	6	7	8	9	10
STOPS	4	9	10	8	8	8	8	10	10	4

**SCALES IN FEET**



**VELOCITIES AND  
 CURRENT DIRECTIONS**  
 4 DEFLECTORS  
 DISCHARGE: 172,300 CFS  
 TAILWATER: 351.0 FT

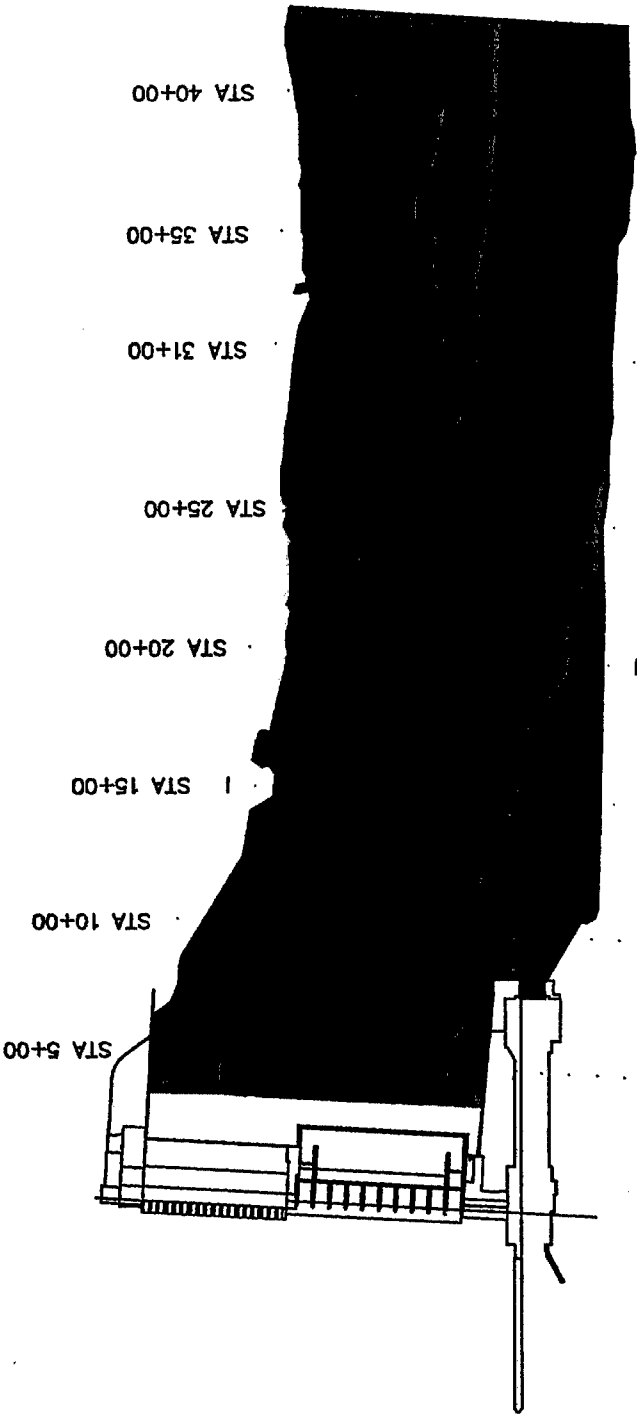

**OPERATING CONDITIONS**

POWERHOUSE DISCHARGE = 72.3 KCFS  
 SPILLWAY DISCHARGE = 30 KCFS  
 HEADPOOL ELEVATION = 000.0  
 TAILWATER ELEVATION = 346.5  
 DEFLECTORS LOCATED AT BAYS 4-7

**LEGEND**

- 0.0 - 2.5 fps
- 2.6 - 5.0 fps
- 5.1 - 7.5 fps
- 7.6 - 10.0 fps
- 10.1 - 12.5 fps
- 12.6 - 15.0 fps
- > 15.1 fps

**POWERHOUSE OPERATION, Q/UNITS, KCFS**

UNIT	1	2	3	4	5	6
Q	12.3	12.3	12.3	17.7	0	17.7

**SPILLWAY OPERATION, STOPS (FT)**

BAY	1	2	3	4	5	6	7	8	9	10
STOPS	1	3	0	2	2	2	2	0	4	1.5

**SCALES IN FEET**



**ISOVEL PLOT**

4 DEFLECTORS  
 DISCHARGE: 102,300 CFS  
 TAILWATER: 346.5 FT

Plate 24

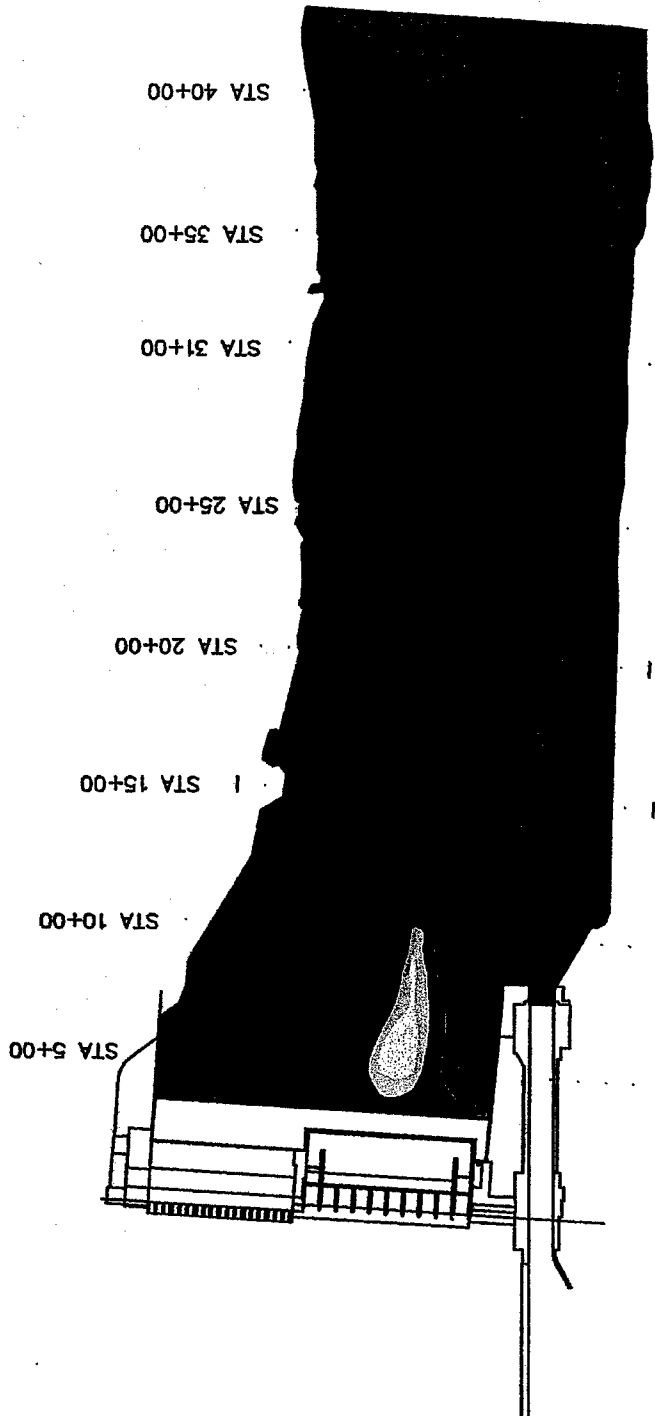

1

**OPERATING CONDITIONS**

POWERHOUSE DISCHARGE = 72.3 KCFS  
 SPILLWAY DISCHARGE = 45 KCFS  
 HEADPOOL ELEVATION = 439.0  
 TAILWATER ELEVATION = 347.7  
 DEFLECTORS LOCATED AT BAYS 4-7

**LEGEND**

- 0.0 - 2.5 fps
- 2.6 - 5.0 fps
- 5.1 - 7.5 fps
- 7.6 - 10.0 fps
- 10.1 - 12.5 fps
- 12.6 - 15.0 fps
- > 15.1 fps

**POWERHOUSE OPERATION, Q/UNITS, KCFS**

UNIT	1	2	3	4	5	6
Q	12.3	12.3	12.3	17.7	0	17.7

**SPILLWAY OPERATION, STOPS (FT)**

BAY	1	2	3	4	5	6	7	8	9	10
STOPS	2	5	0	3	3	3	3	0	5	2

**ISOVEL PLOT**

4 DEFLECTORS  
 DISCHARGE: 117,300 CFS  
 TAILWATER: 347.7 FT

**SCALES IN FEET**



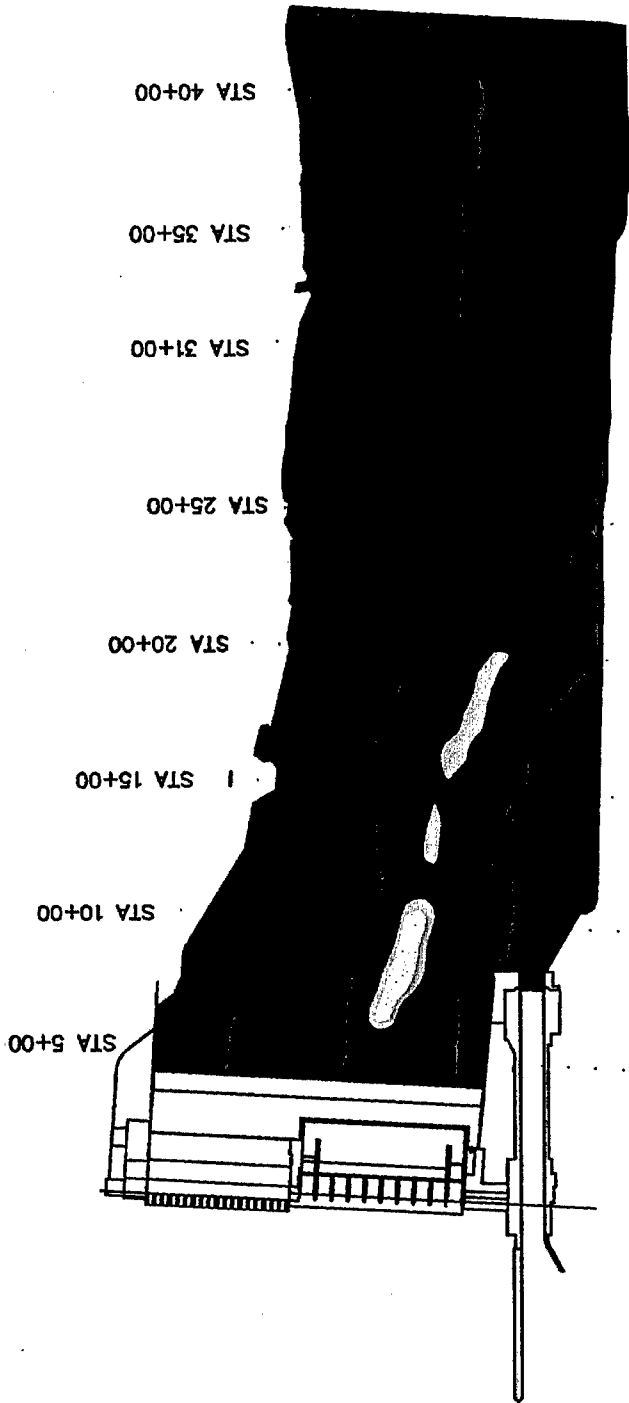

STA 40+00  
 STA 35+00  
 STA 31+00  
 STA 25+00  
 STA 20+00  
 STA 15+00  
 STA 10+00  
 STA 5+00

**OPERATING CONDITIONS**  
 POWERHOUSE DISCHARGE = 72.3 KCFS  
 SPILLWAY DISCHARGE = 55 KCFS  
 HEADPOOL ELEVATION = 438.0  
 TAILWATER ELEVATION = 348.3

**POWERHOUSE OPERATION, Q/UNITS, KCFS**

UNIT	1	2	3	4	5	6
Q	12.3	12.3	12.3	17.7	0	17.7

**SPILLWAY OPERATION, STOPS (FT)**

BAY	1	2	3	4	5	6	7	8	9	10
STOPS	2	5	0	4	4	4	4	0	8	5

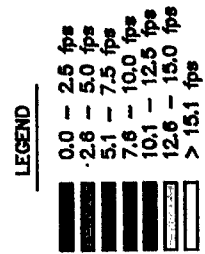

**ISOVEL PLOT**  
 4 DEFLECTORS  
 DISCHARGE: 127,300 CFS  
 TAILWATER: 348.3 FT



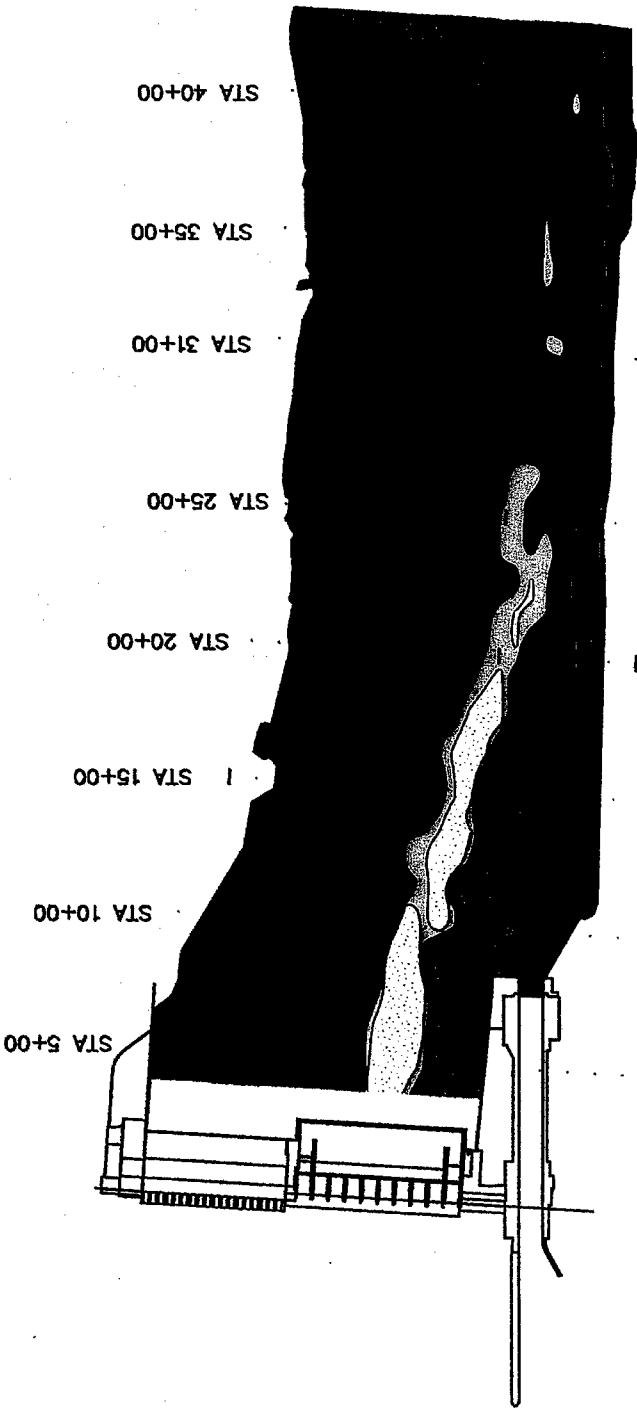

STA 40+00  
 STA 35+00  
 STA 31+00  
 STA 25+00  
 STA 20+00  
 STA 15+00  
 STA 10+00  
 STA 5+00

**OPERATING CONDITIONS**  
 POWERHOUSE DISCHARGE = 72.3 KCFS  
 SPILLWAY DISCHARGE = 75 KCFS  
 HEADPOOL ELEVATION = 439.0  
 TAILWATER ELEVATION = 349.7

**POWERHOUSE OPERATION, Q/UNITS, KCFS**

UNIT	1	2	3	4	5	6
Q	12.3	12.3	12.3	17.7	0	17.7

**SPILLWAY OPERATION, STOPS (FT)**

BAY	1	2	3	4	5	6	7	8	9	10
STOPS	3	8	0	5	6	6	5	0	8	5

**LEGEND**

[Pattern]	0.0 - 2.5 fps
[Pattern]	2.6 - 5.0 fps
[Pattern]	5.1 - 7.5 fps
[Pattern]	7.6 - 10.0 fps
[Pattern]	10.1 - 12.5 fps
[Pattern]	12.6 - 15.0 fps
[Pattern]	> 15.1 fps

**ISOVEL PLOT**  
 4 DEFLECTORS  
 DISCHARGE: 147,300 CFS  
 TAILWATER: 349.7 FT



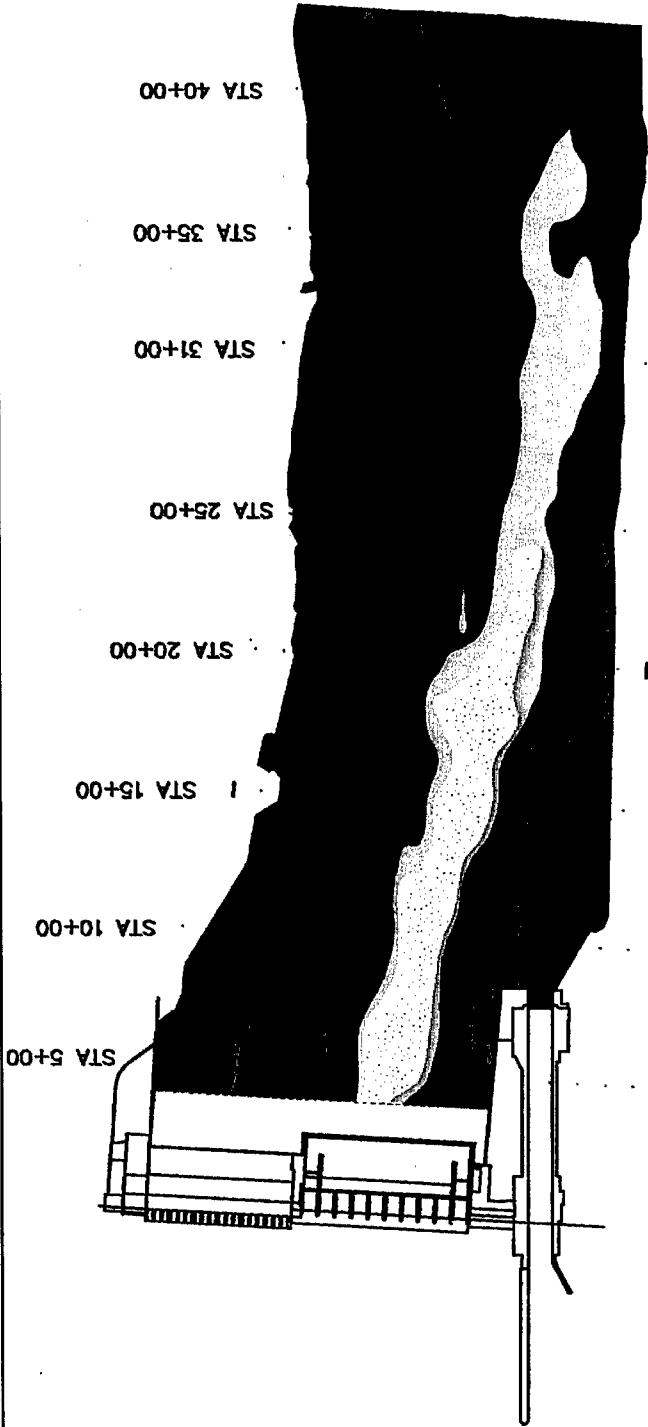

Plate 28

**OPERATING CONDITIONS**  
 POWERHOUSE DISCHARGE = 72.3 KCFS  
 SPILLWAY DISCHARGE = 100 KCFS  
 HEADPOOL ELEVATION = 439.0  
 TAILWATER ELEVATION = 351.0

**LEGEND**

[Pattern]	0.0 - 2.5 fps
[Pattern]	2.6 - 5.0 fps
[Pattern]	5.1 - 7.5 fps
[Pattern]	7.6 - 10.0 fps
[Pattern]	10.1 - 12.5 fps
[Pattern]	12.6 - 15.0 fps
[Pattern]	> 15.1 fps

**POWERHOUSE OPERATION, Q/UNITS, KCFS**

UNIT	1	2	3	4	5	6
Q	12.3	12.3	12.3	17.7	0	17.7

**SPILLWAY OPERATION, STOPS (FT)**

BAY	1	2	3	4	5	6	7	8	9	10
STOPS	4	9	0	8	8	8	6	0	10	4



**ISOVEL PLOT**  
 4 DEFLECTORS  
 DISCHARGE: 172,300 CFS  
 TAILWATER: 351.0 FT

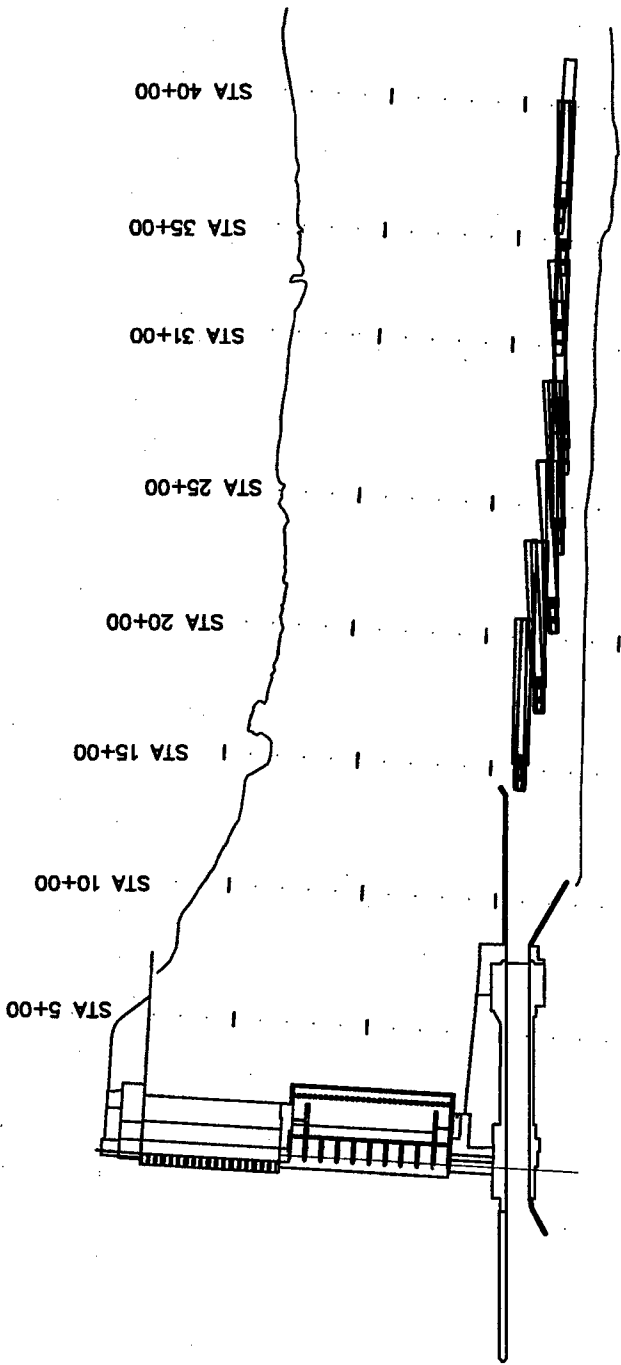

**OPERATING CONDITIONS**

POWERHOUSE DISCHARGE = 72.3 KCFS  
 SPILLWAY DISCHARGE = 30 KCFS  
 HEADPOOL ELEVATION = 439.0  
 TAILWATER ELEVATION = 346.5

**POWERHOUSE OPERATION, Q/UNITS, KCFS**

UNIT	1	2	3	4	5	6
Q	12.3	12.3	12.3	17.7	0	17.7

**SPILLWAY OPERATION, STOPS (FT)**

BAY	1	2	3	4	5	6	7	8	9	10
STOPS	1	3	10	2	2	2	2	2	0	4

**LEGEND**

2-BARGE TOW: 1 WIDE X 2 LONG  
 42 ft WIDE X 548 ft LONG X 13 ft DRAFT  
 WITH 100-ft PUSHER BOAT

**SCALES IN FEET**



TOW PATHS  
 DOWNBOUND  
 4 DEFLECTORS  
 2-BARGE FLOTILLA  
 (1 wide x 2 long)  
 DISCHARGE: 102,300 CFS  
 TAILWATER EL: 346.5 FT

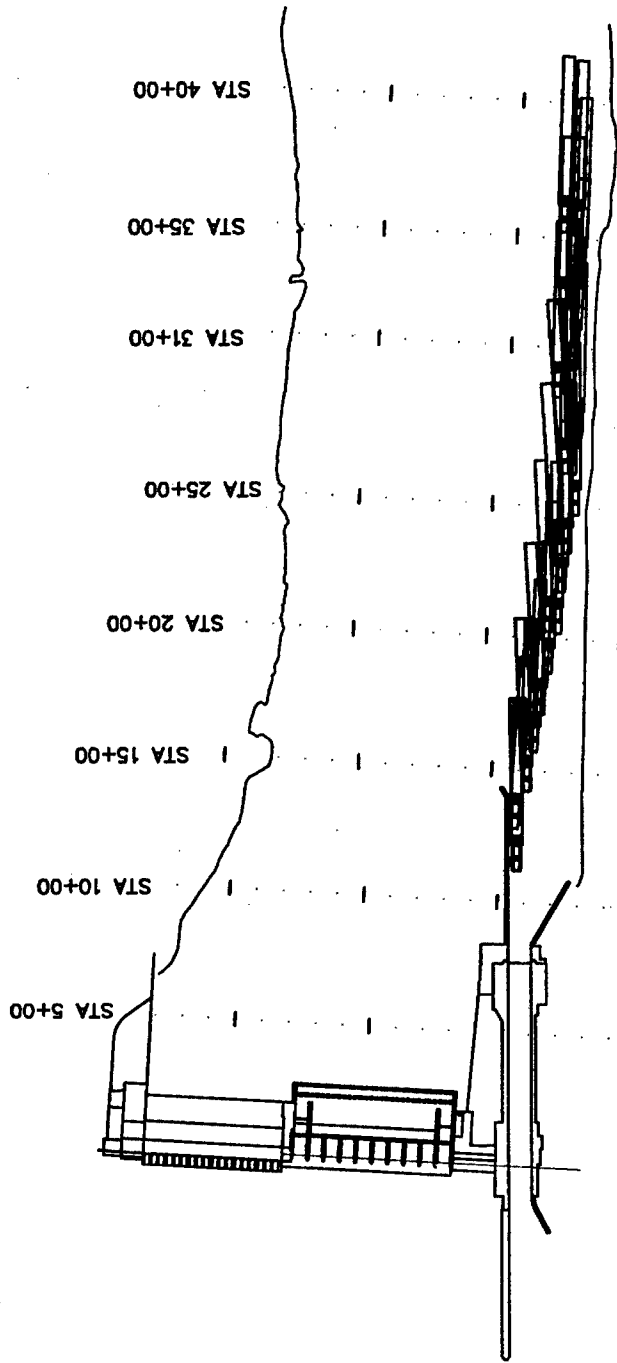

**OPERATING CONDITIONS**  
 POWERHOUSE DISCHARGE = 72.3 KCFS  
 SPILLWAY DISCHARGE = 55 KCFS  
 HEADPOOL ELEVATION = 439.0  
 TAILWATER ELEVATION = 348.3

**POWERHOUSE OPERATION, Q/UNITS, KCFS**

UNIT	1	2	3	4	5	6
Q	12.3	12.3	12.3	17.7	0	17.7

**SPILLWAY OPERATION, STOPS (FT)**

BAY	1	2	3	4	5	6	7	8	9	10
STOPS	2	5	0	4	4	4	4	10	6	3

**LEGEND**

2-BARGE TOW: 1 WIDE X 2 LONG  
 42 ft WIDE X 548 ft LONG X 13 ft DRAFT  
 WITH 100-ft PUSHER BOAT

**SCALES IN FEET**



TOW PATHS  
 DOWNBOUND  
 4 DEFLECTORS  
 2-BARGE FLOTILLA  
 (1 wide x 2 long)  
 DISCHARGE: 127,300 CFS  
 TAILWATER EL: 348.3 FT

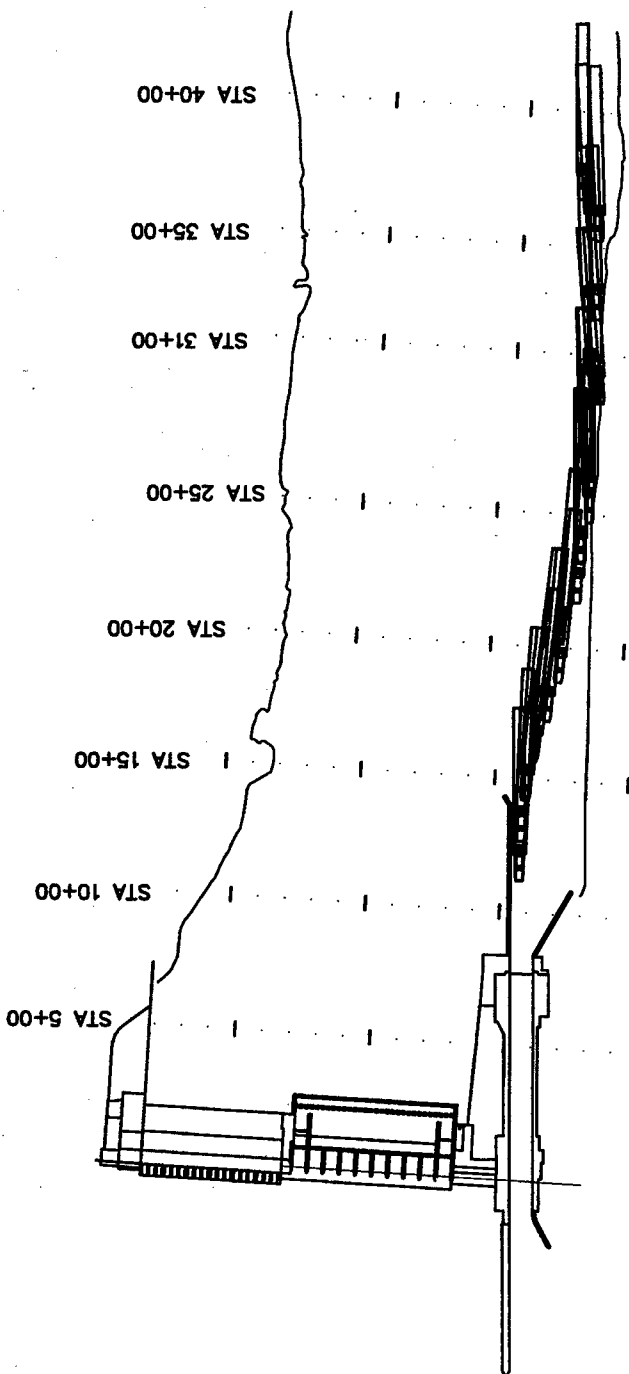

TOW PATHS  
 DOWNBOUND  
 4 DEFLECTORS  
 1-BARGE FLOTILLA  
 (1 wide x 2 long)  
 DISCHARGE: 172,300 CFS  
 TAILWATER EL: 351.0 FT

POWERHOUSE OPERATION, Q/UNITS, KCFS

UNIT	1	2	3	4	5	6
Q	12.3	12.3	12.3	17.7	0	17.7

SPILLWAY OPERATION, STOPS (FT)

BAY	1	2	3	4	5	6	7	8	9	10
STOPS	4	9	0	8	8	8	8	8	0	10

OPERATING CONDITIONS

POWERHOUSE DISCHARGE = 72.3 KCFS  
 SPILLWAY DISCHARGE = 100 KCFS  
 HEADPOOL ELEVATION = 439.0  
 TAILWATER ELEVATION = 351.0

LEGEND

2-BARGE TOW: 1 WIDE X 2 LONG  
 42 ft WIDE X 548 ft LONG X 13 ft DRAFT  
 WITH 100-ft PUSHER BOAT

SCALES IN FEET



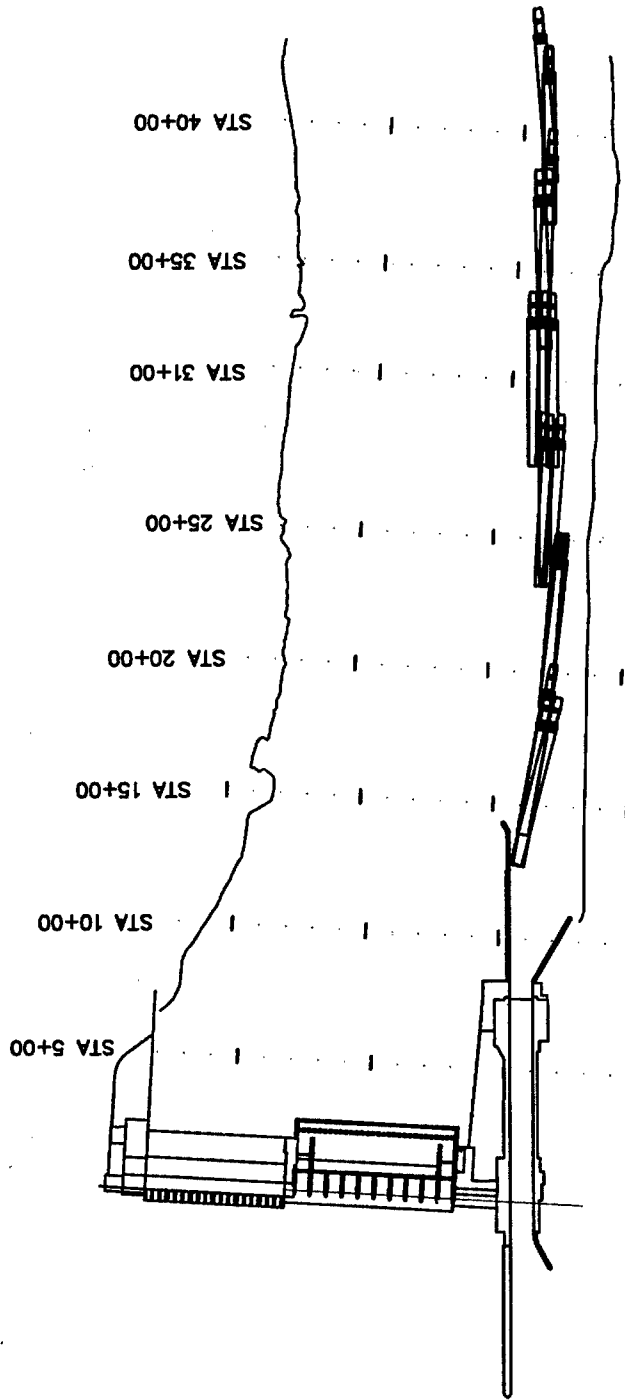

**OPERATING CONDITIONS**  
 POWERHOUSE DISCHARGE = 72.3 KCFS  
 SPILLWAY DISCHARGE = 30 KCFS  
 HEADPOOL ELEVATION = 439.0  
 TAILWATER ELEVATION = 346.5

**POWERHOUSE OPERATION, Q/UNITS, KCFS**

UNIT	1	2	3	4	5	6
Q	12.3	12.3	12.3	17.7	0	17.7

**SPILLWAY OPERATION, STOPS (FT)**

BAY	1	2	3	4	5	6	7	8	9	10
STOPS	1	3	0	2	2	2	2	2	0	4
										11.5

**LEGEND**

2-BARGE TOW: 1 WIDE X 2 LONG  
 42 ft WIDE X 548 ft LONG X 13 ft DRAFT  
 WITH 100-ft PUSHER BOAT

TOWPATHS  
 UPBOUND  
 4 DEFLECTORS  
 2-BARGE FLOTILLA  
 (1 wide x 2 long)  
 DISCHARGE: 102,300 CFS  
 TAILWATER EL: 346.5 FT

**SCALES IN FEET**



Plate 32

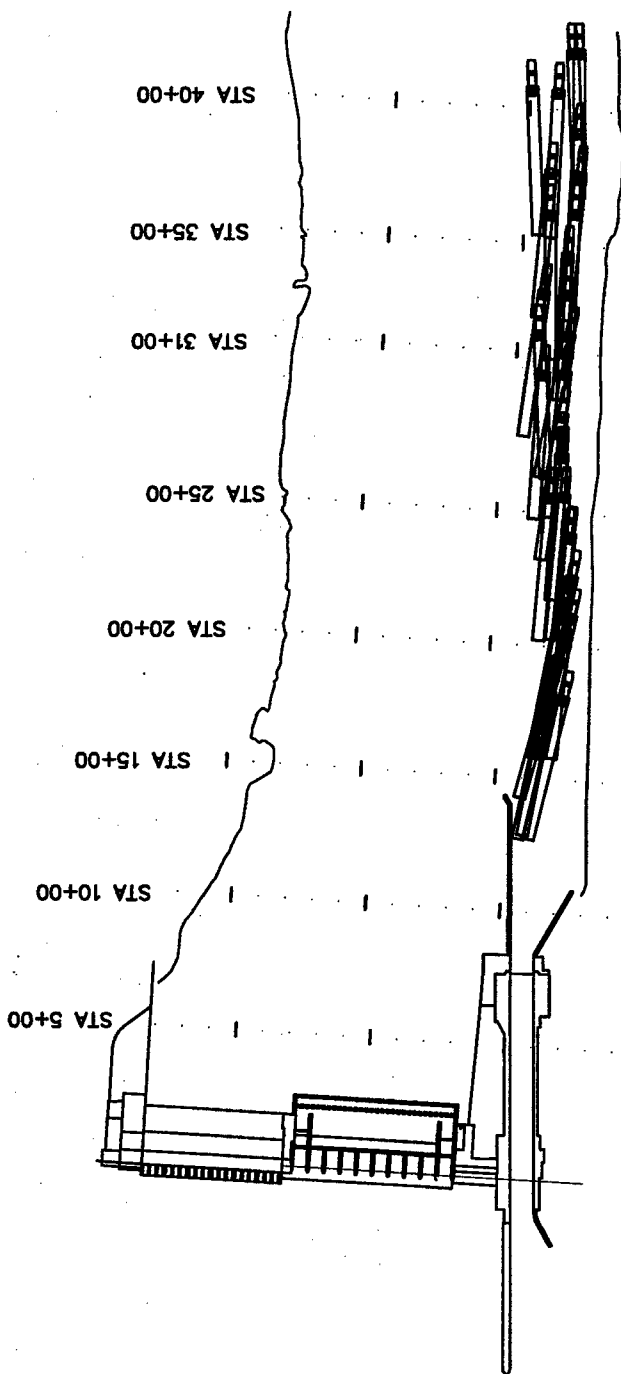

**OPERATING CONDITIONS**

POWERHOUSE DISCHARGE = 72.3 KCFS  
 SPILLWAY DISCHARGE = 55 KCFS  
 HEADPOOL ELEVATION = 438.0  
 TAILWATER ELEVATION = 348.3

**POWERHOUSE OPERATION, Q/UNITS, KCFS**

UNIT	1	2	3	4	5	6
Q	12.3	12.3	12.3	17.7	0	17.7

**SPILLWAY OPERATION, STOPS (FT)**

BAY	1	2	3	4	5	6	7	8	9	10
STOPS	2	5	0	4	4	4	4	0	5	3

**LEGEND**

2--BARGE TOW: 1 WIDE X 2 LONG  
 42 ft WIDE X 548 ft LONG X 13 ft DRAFT  
 WITH 100-ft PUSHER BOAT

**SCALES IN FEET**



TOW PATHS  
 UPBOUND  
 4 DEFLECTORS  
 2--BARGE FLOTILLA  
 (1 wide x 2 long)  
 DISCHARGE: 127,300 CFS  
 TAILWATER EL: 348.3 FT

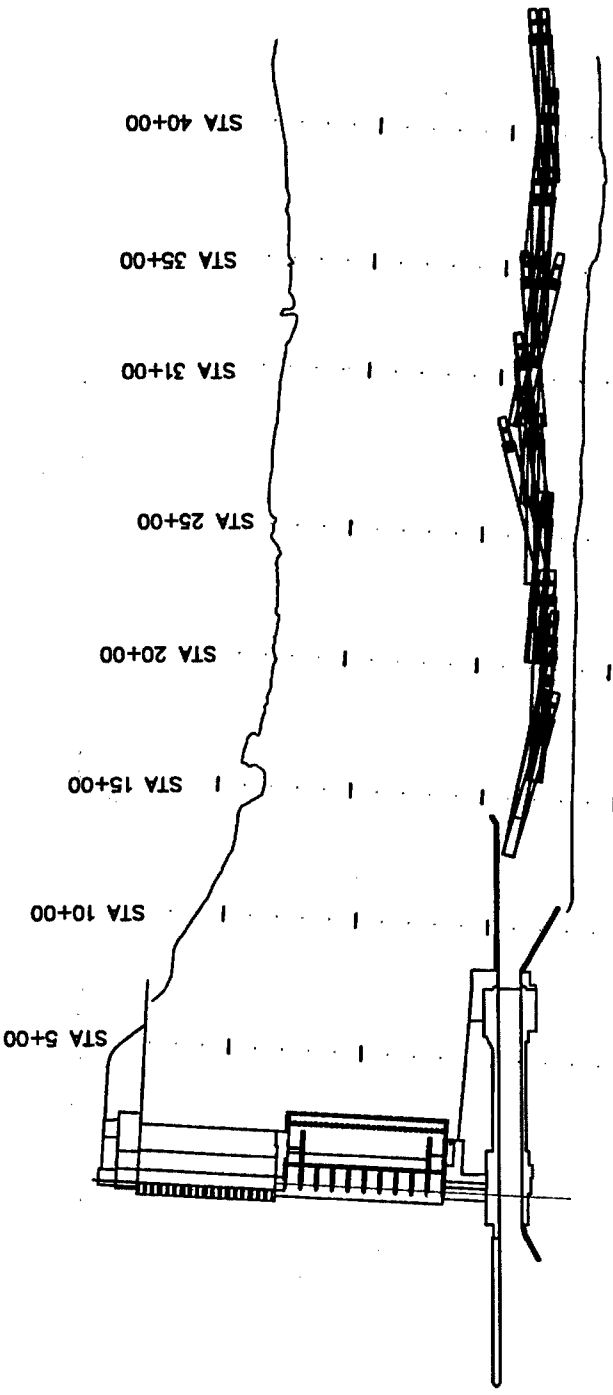

**OPERATING CONDITIONS**  
 POWERHOUSE DISCHARGE = 72.3 KCFS  
 SPILLWAY DISCHARGE = 100 KCFS  
 HEADPOOL ELEVATION = 439.0  
 TAILWATER ELEVATION = 351.0

**POWERHOUSE OPERATION, Q/UNITS, KCFS**

UNIT	1	2	3	4	5	6
Q	12.3	12.3	12.3	17.7	0	17.7

**SPILLWAY OPERATION, STOPS (FT)**

BAY	1	2	3	4	5	6	7	8	9	10
STOPS	4	9	0	8	8	8	8	10	10	4

**LEGEND**

2-BARGE TOW: 1 WIDE X 2 LONG  
 42 ft WIDE X 548 ft LONG X 13 ft DRAFT  
 WITH 100-ft PUSHER BOAT

**SCALES IN FEET**



TOW PATHS  
 UPBOUND  
 4 DEFLECTORS  
 1-BARGE FLOTILLA  
 (1 wide x 2 long)  
 DISCHARGE: 172,300 CFS  
 TAILWATER EL: 351.0 FT

Plate 34

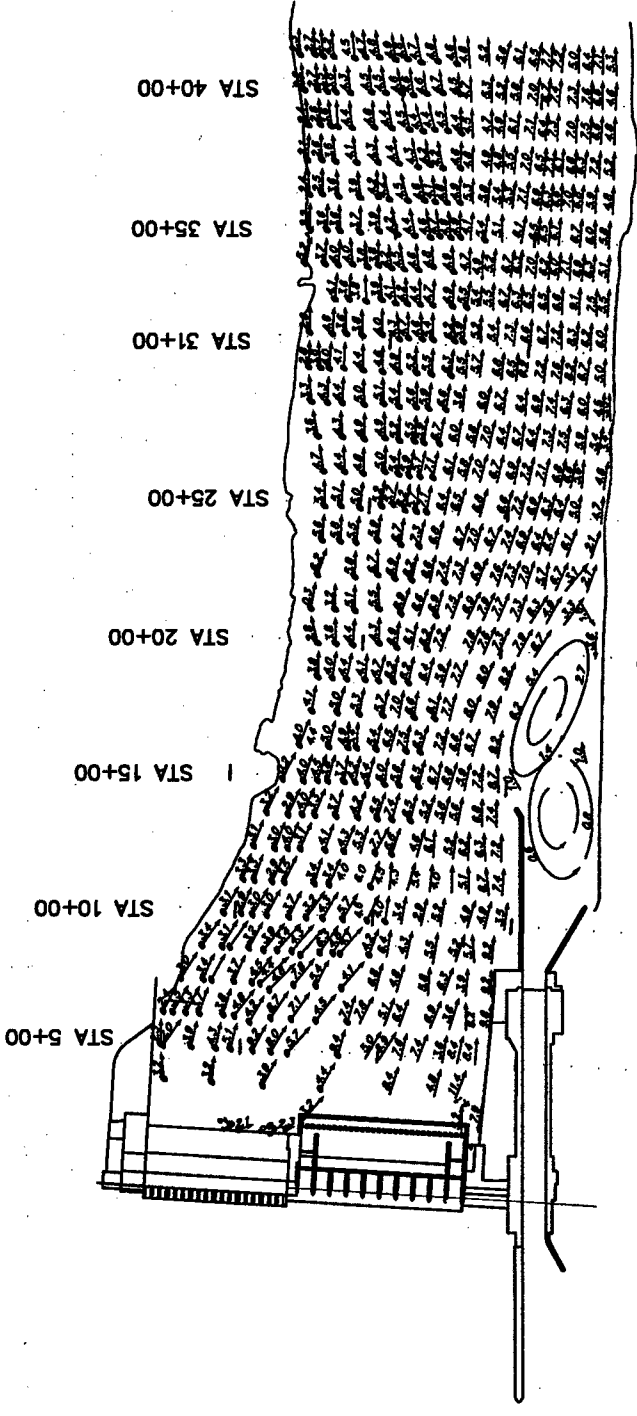

**OPERATING CONDITIONS**

POWERHOUSE DISCHARGE = 72.3 KCFS  
 SPILLWAY DISCHARGE = 30 KCFS  
 HEADPOOL ELEVATION = 439.0  
 TAILWATER ELEVATION = 346.5  
 DEFLECTORS LOCATED AT BAYS 2-9

**LEGEND**

VELOCITY IN FEET PER SECOND (13.0 ft DRAFT)  
 VELOCITY IN FEET PER SECOND (7.0 ft DRAFT)  
 VELOCITIES AND CURRENT DIRECTION  
 OBTAINED WITH FLOATS SUBMERGED TO  
 DRAFT OF 13.0 ft and 7.0 ft

**POWERHOUSE OPERATION, Q/UNITS, KCFS**

UNIT	1	2	3	4	5	6
Q	12.3	12.3	12.3	17.7	0	17.7

**SPILLWAY OPERATION, STOPS (FT)**

BAY	1	2	3	4	5	6	7	8	9	10
STOPS	1	2	2	2	2	1	2	2	1	2

**SCALES IN FEET**



**VELOCITIES AND  
 CURRENT DIRECTIONS**  
 8 DEFLECTORS  
 DISCHARGE: 102,300 CFS  
 TAILWATER: 346.5 FT

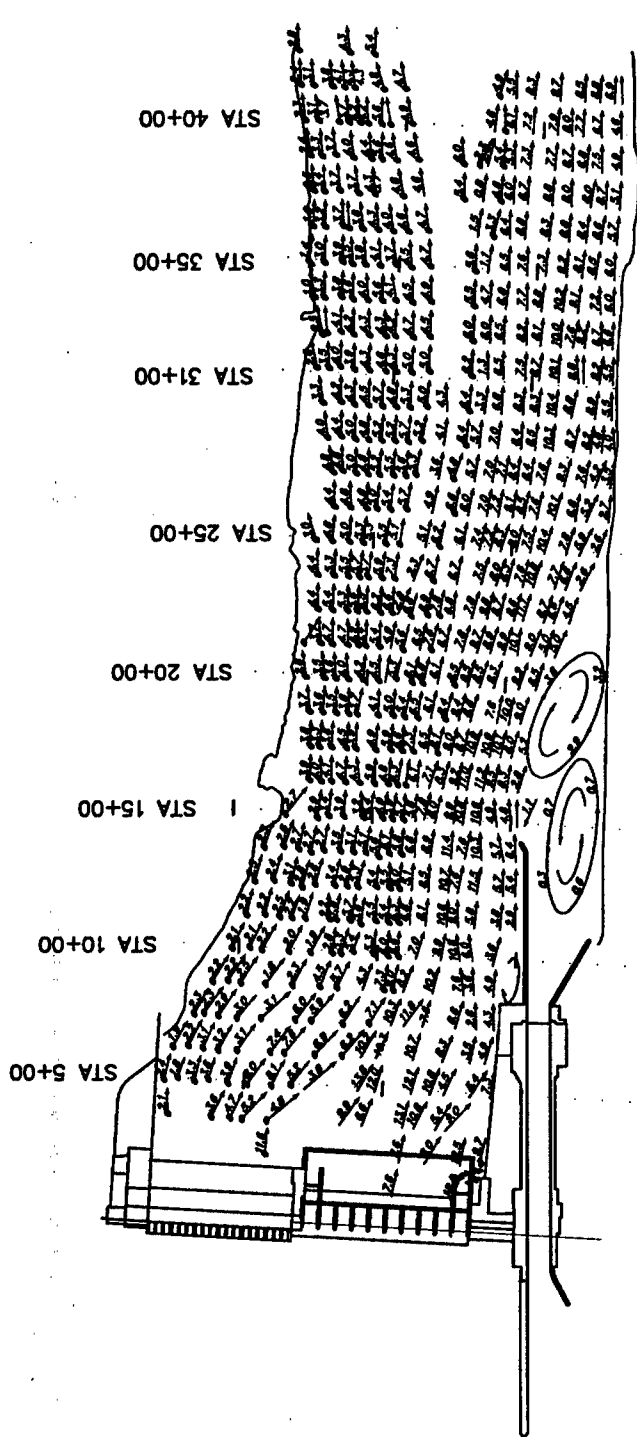

**VELOCITIES AND  
CURRENT DIRECTIONS**  
8 DEFLECTORS  
DISCHARGE: 117,300 CFS  
TAILWATER: 347.7 FT

**POWERHOUSE OPERATION, Q/UNITS, KCFS**

UNIT	1	2	3	4	5	6
Q	12.3	12.3	12.3	17.7	0	17.7

**SPILLWAY OPERATION, STOPS (FT)**

BAY	1	2	3	4	5	6	7	8	9	10
STOPS	2	3	3	3	3	3	3	3	2	1.5

**SCALES IN FEET**



**OPERATING CONDITIONS**

POWERHOUSE DISCHARGE = 72.3 KCFS  
 SPILLWAY DISCHARGE = 45 KCFS  
 HEADPOOL ELEVATION = 439.0  
 TAILWATER ELEVATION = 347.7  
 DEFLECTORS LOCATED AT BAYS 2-9

**LEGEND**

VELOCITY IN FEET PER SECOND (13.0 ft DRAFT)  
 VELOCITY IN FEET PER SECOND (7.0 ft DRAFT)

NOTE: VELOCITIES AND CURRENT DIRECTION  
 OBTAINED WITH FLOATS SUBMERGED TO  
 DRAFT OF 13.0 ft and 7.0 ft

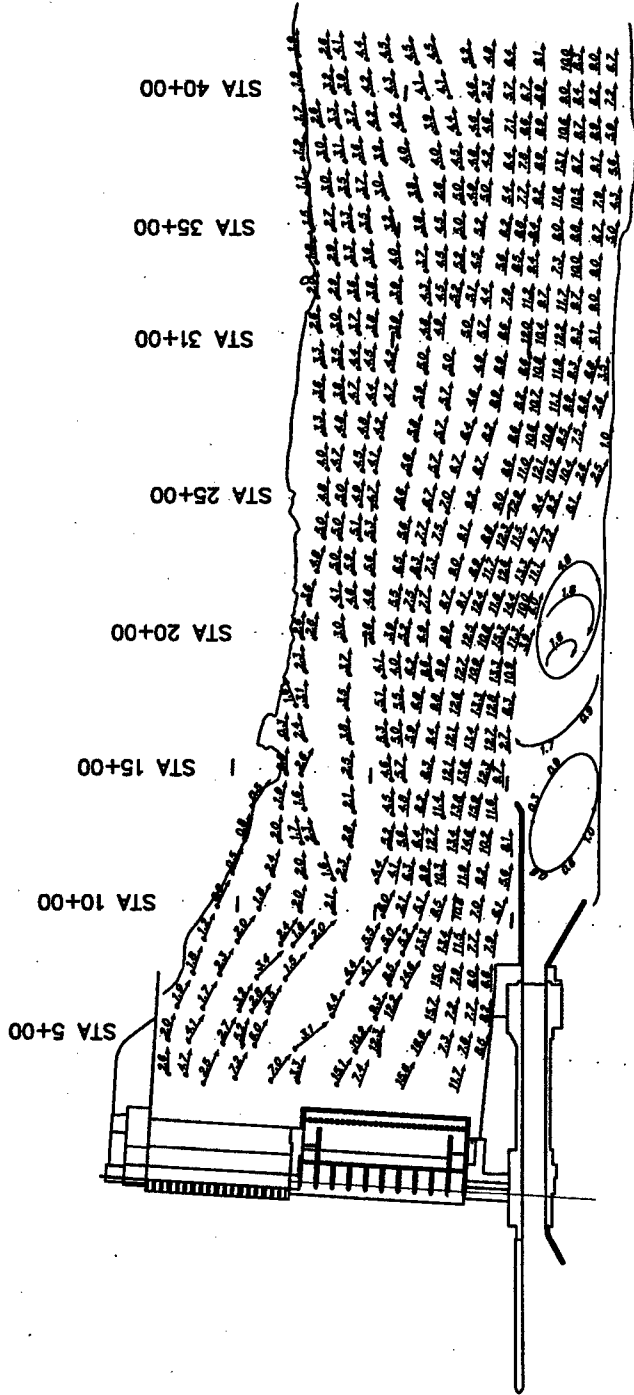

**OPERATING CONDITIONS**

POWERHOUSE DISCHARGE = 72.3 KCFS  
 SPILLWAY DISCHARGE = 55 KCFS  
 HEADPOOL ELEVATION = 439.0  
 TAILWATER ELEVATION = 348.3  
 DEFLECTORS LOCATED AT BAYS 2-9

**LEGEND**

— 3.5 — VELOCITY IN FEET PER SECOND (13.0 ft DRAFT)  
 — 2.7 — VELOCITY IN FEET PER SECOND (7.0 ft DRAFT)

NOTE : VELOCITIES AND CURRENT DIRECTION  
 OBTAINED WITH FLOATS SUBMERGED TO  
 DRAFT OF 13.0 ft and 7.0 ft

**POWERHOUSE OPERATION, Q/UNITS, KCFS**

UNIT	1	2	3	4	5	6
Q	12.3	12.3	12.3	17.7	0	17.7

**SPILLWAY OPERATION, STOPS (FT)**

BAY	1	2	3	4	5	6	7	8	9	10
STOPS	2	3	3	4	4	4	4	4	4	1.5

**SCALES IN FEET**



**VELOCITIES AND  
 CURRENT DIRECTIONS**  
 8 DEFLECTORS  
 DISCHARGE: 127,300 CFS  
 TAILWATER: 348.3 FT

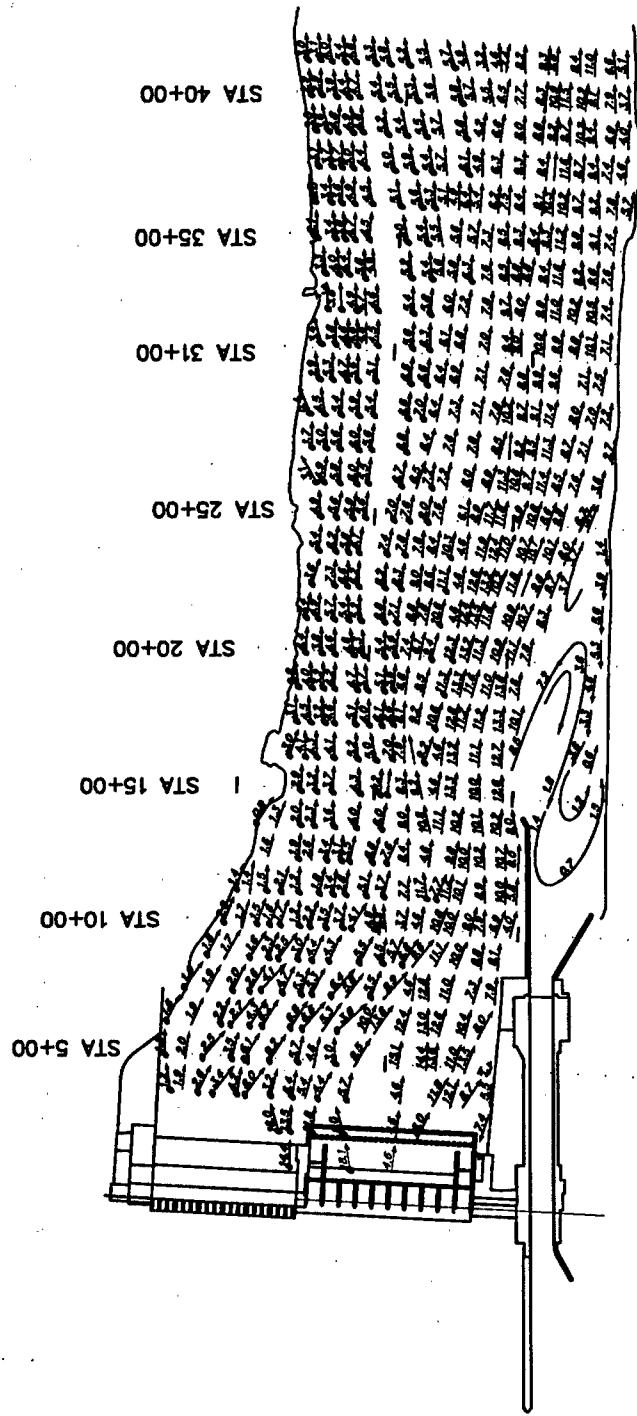

**VELOCITIES AND  
CURRENT DIRECTIONS**  
8 DEFLECTORS  
DISCHARGE: 147,300 CFS  
TAILWATER: 349.7 FT

**POWERHOUSE OPERATION, Q/UNITS, KCFS**

UNIT	1	2	3	4	5	6
Q	12.3	12.3	12.3	17.7	0	17.7

**SPILLWAY OPERATION, STOPS (FT)**

BAY	1	2	3	4	5	6	7	8	9	10
STOPS	2	8	5	5	5	5	5	5	5	5

**SCALES IN FEET**



**OPERATING CONDITIONS**

POWERHOUSE DISCHARGE = 72.3 KCFS  
 SPILLWAY DISCHARGE = 75 KCFS  
 HEADPOOL ELEVATION = 439.0  
 TAILWATER ELEVATION = 349.7  
 DEFLECTORS LOCATED AT BAYS 2-9

**LEGEND**

VELOCITY IN FEET PER SECOND (13.0 ft DRAFT)  
 VELOCITY IN FEET PER SECOND (7.0 ft DRAFT)  
 VELOCITIES AND CURRENT DIRECTION  
 OBTAINED WITH FLOATS SUBMERGED TO  
 DRAFT OF 13.0 ft and 7.0 ft

13  
7

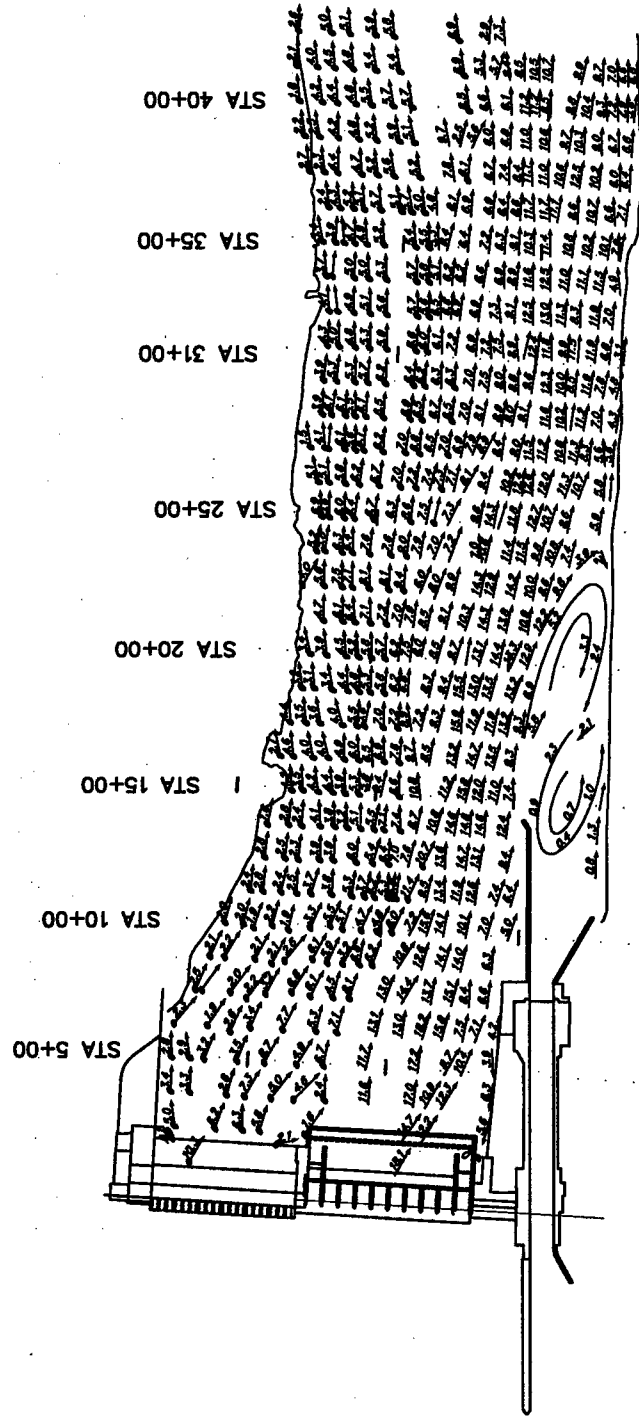

**OPERATING CONDITIONS**

POWERHOUSE DISCHARGE = 72.3 KCFS  
 SPILLWAY DISCHARGE = 100 KCFS  
 HEADPOOL ELEVATION = 439.0  
 TAILWATER ELEVATION = 351.0  
 DEFLECTORS LOCATED AT BAYS 2-9

**POWERHOUSE OPERATION, Q/UNITS, KCFS**

UNIT	1	2	3	4	5	6
Q	12.3	12.3	12.3	17.7	0	17.7

**SPILLWAY OPERATION, STOPS (FT)**

BAY	1	2	3	4	5	6	7	8	9	10
STOPS	2	7	7	7	7	7	7	7	6	2

**LEGEND**

VELOCITY IN FEET PER SECOND (13.0 ft DRAFT)  
 VELOCITY IN FEET PER SECOND (7.0 ft DRAFT)  
 VELOCITIES AND CURRENT DIRECTION  
 OBTAINED WITH FLOATS SUBMERGED TO  
 DRAFT OF 13.0 ft and 7.0 ft

**VELOCITIES AND  
 CURRENT DIRECTIONS**  
 8 DEFLECTORS  
 DISCHARGE: 172,300 CFS  
 TAILWATER: 351.0 FT

**SCALES IN FEET**



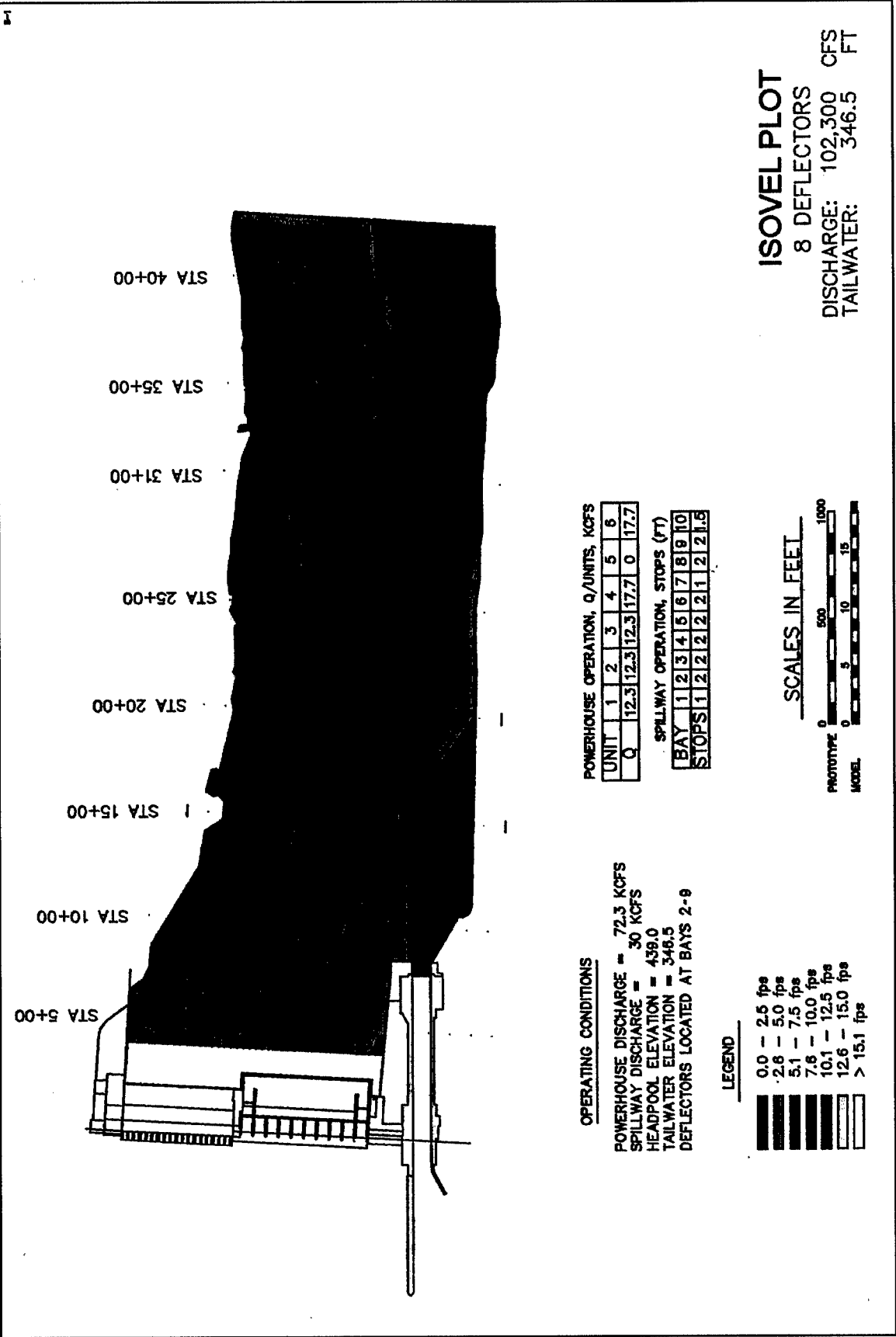

**ISOVEL PLOT**  
 8 DEFLECTORS  
 DISCHARGE: 102,300 CFS  
 TAILWATER: 346.5 FT

STA 40+00  
 STA 35+00  
 STA 31+00  
 STA 25+00  
 STA 20+00  
 STA 15+00  
 STA 10+00  
 STA 5+00

**POWERHOUSE OPERATION, Q/UNITS, KCFS**

UNIT	1	2	3	4	5	6
Q	12.3	12.3	12.3	17.7	0	17.7

**SPILLWAY OPERATION, STOPS (FT)**

BAY	1	2	3	4	5	6	7	8	9	10
STOPS	1	2	2	2	2	1	2	2	2	1.6

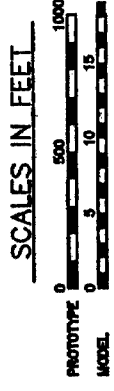

**OPERATING CONDITIONS**  
 POWERHOUSE DISCHARGE = 72.3 KCFS  
 SPILLWAY DISCHARGE = 30 KCFS  
 HEADPOOL ELEVATION = 439.0  
 TAILWATER ELEVATION = 346.5  
 DEFLECTORS LOCATED AT BAYS 2-9

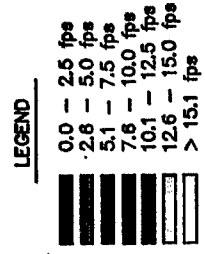
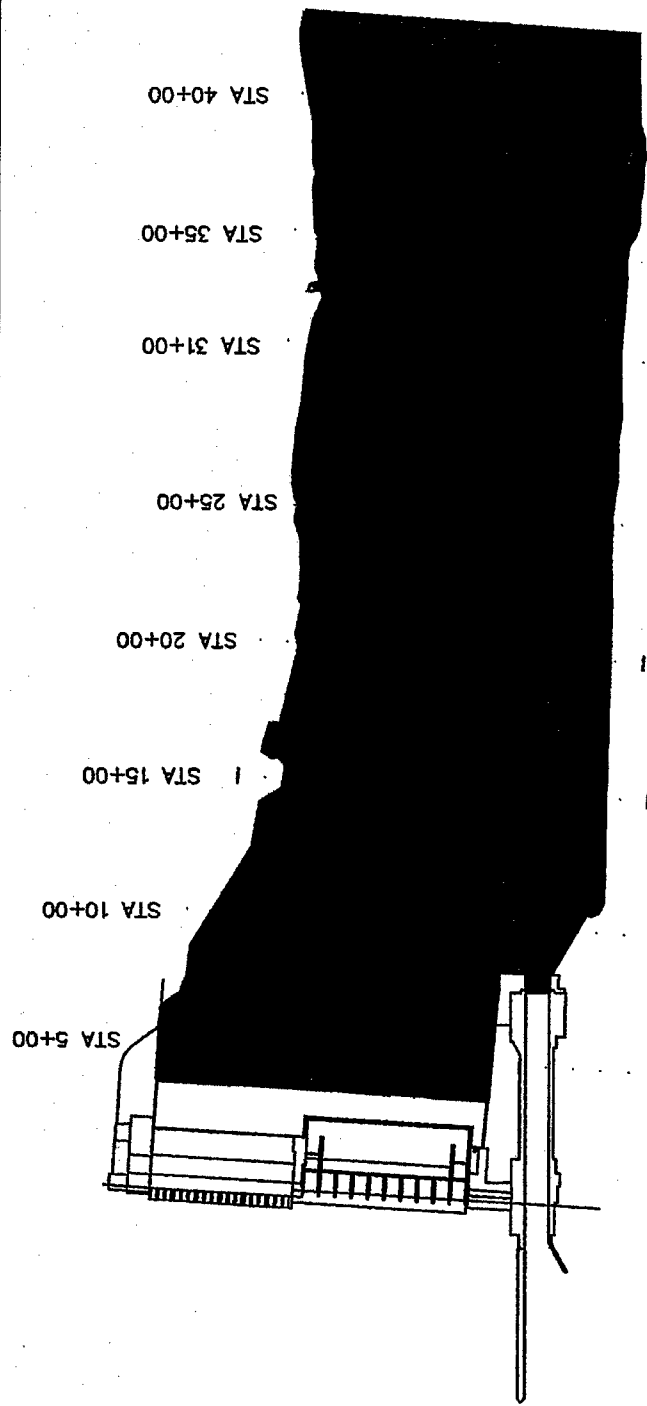

Plate 40



**OPERATING CONDITIONS**

POWERHOUSE DISCHARGE = 72.3 KCFS  
 SPILLWAY DISCHARGE = 45 KCFS  
 HEADPOOL ELEVATION = 439.0  
 TAILWATER ELEVATION = 347.7  
 DEFLECTORS LOCATED AT BAYS 2-9

**POWERHOUSE OPERATION, Q/UNITS, KCFS**

UNIT	1	2	3	4	5	6
Q	12.3	12.3	12.3	17.7	0	17.7

**SPILLWAY OPERATION, STOPS (FT)**

BAY	1	2	3	4	5	6	7	8	9	10
STOPS	2	3	3	3	3	3	3	3	2	1.5

**LEGEND**

- 0.0 - 2.5 fps
- 2.6 - 5.0 fps
- 5.1 - 7.5 fps
- 7.6 - 10.0 fps
- 10.1 - 12.5 fps
- 12.6 - 15.0 fps
- > 15.1 fps

**ISOVEL PLOT**

8 DEFLECTORS  
 DISCHARGE: 117,300 CFS  
 TAILWATER: 347.7 FT

**SCALES IN FEET**



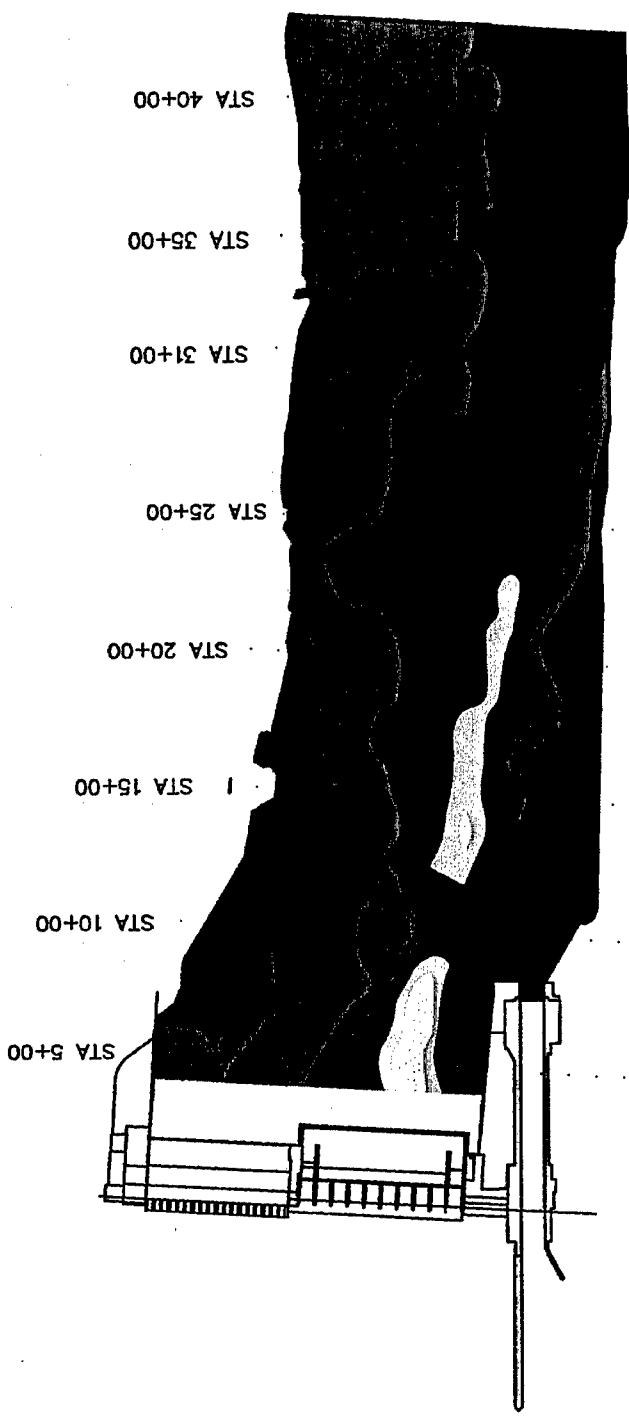

STA 5+00  
STA 10+00  
STA 15+00  
STA 20+00  
STA 25+00  
STA 31+00  
STA 35+00  
STA 40+00

**OPERATING CONDITIONS**  
 POWERHOUSE DISCHARGE = 72.3 KCFS  
 SPILLWAY DISCHARGE = 55 KCFS  
 HEADPOOL ELEVATION = 439.0  
 TAILWATER ELEVATION = 348.3  
 DEFLECTORS LOCATED AT BAYS 2-8

**POWERHOUSE OPERATION, Q/UNITS, KCFS**

UNIT	1	2	3	4	5	6
Q	12.3	12.3	12.3	17.7	0	17.7

**SPILLWAY OPERATION, STOPS (FT)**

BAY	1	2	3	4	5	6	7	8	9	10
STOPS	2	3	3	4	4	4	4	4	4	13

- LEGEND**
- 0.0 - 2.5 fps
  - 2.6 - 5.0 fps
  - 5.1 - 7.5 fps
  - 7.6 - 10.0 fps
  - 10.1 - 12.5 fps
  - 12.6 - 15.0 fps
  - > 15.1 fps

**ISOVEL PLOT**  
 8 DEFLECTORS  
 DISCHARGE: 127,300 CFS  
 TAILWATER: 348.3 FT

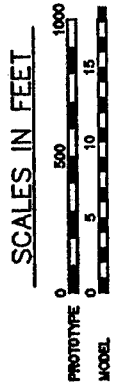

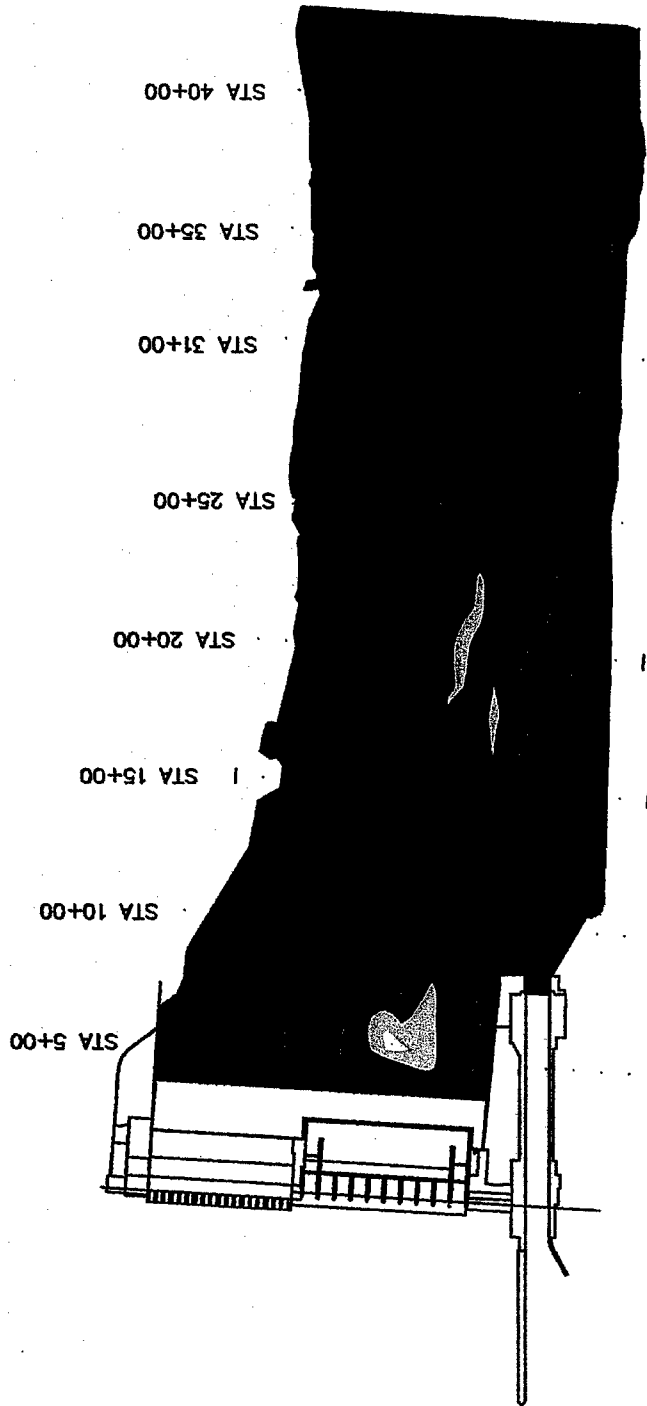

**ISOVEL PLOT**  
**VELOCITIES AND**  
**CURRENT DIRECTIONS**  
**8 DEFLECTORS**  
**DISCHARGE: 147,300 CFS**  
**TAILWATER: 349.7 FT**

POWERHOUSE OPERATION, Q/UNITS, KCFS

UNIT	1	2	3	4	5	6
Q	12.3	12.3	12.3	17.7	0	17.7

SPILLWAY OPERATION, STOPS (FT)

BAY	1	2	3	4	5	6	7	8	9	10
STOPS	2	6	5	5	5	5	5	5	5	5

**OPERATING CONDITIONS**  
 POWERHOUSE DISCHARGE = 72.3 KCFS  
 SPILLWAY DISCHARGE = 75 KCFS  
 HEADPOOL ELEVATION = 439.0  
 TAILWATER ELEVATION = 349.7  
 DEFLECTORS LOCATED AT BAYS 2-9

**LEGEND**

[Thinnest Line]	0.0 - 2.5 fps
[Thin Line]	2.6 - 5.0 fps
[Medium Line]	5.1 - 7.5 fps
[Thick Line]	7.6 - 10.0 fps
[Very Thick Line]	10.1 - 12.5 fps
[Darkest Line]	12.6 - 15.0 fps
[White Box]	> 15.1 fps

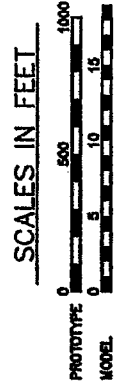

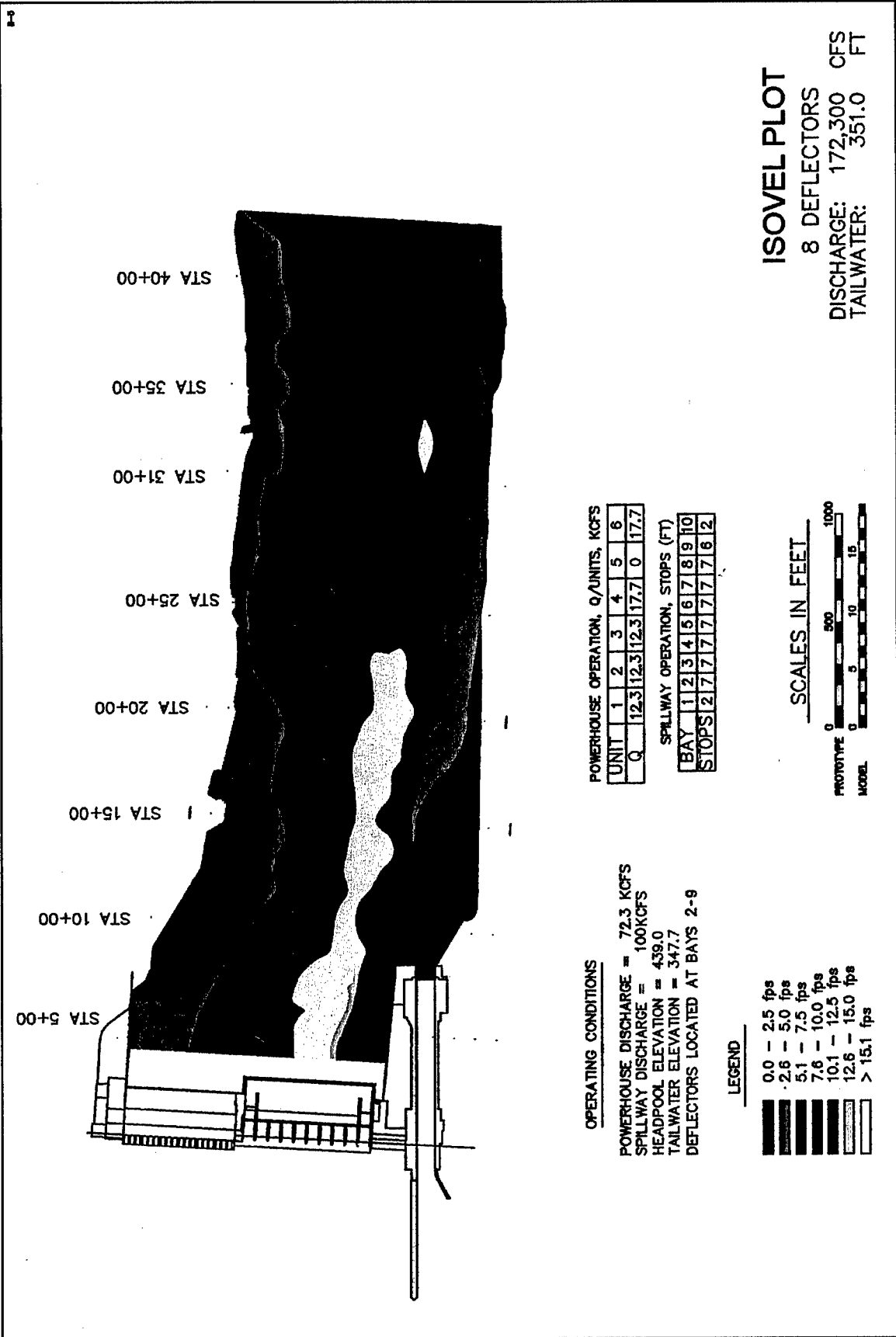

STA 5+00

STA 10+00

STA 15+00

STA 20+00

STA 25+00

STA 31+00

STA 35+00

STA 40+00

**OPERATING CONDITIONS**

POWERHOUSE DISCHARGE = 72.3 KCFS  
 SPILLWAY DISCHARGE = 100 KCFS  
 HEADPOOL ELEVATION = 439.0  
 TAILWATER ELEVATION = 347.7  
 DEFLECTORS LOCATED AT BAYS 2-9

**LEGEND**



**POWERHOUSE OPERATION, Q/UNITS, KCFS**

UNIT	1	2	3	4	5	6
Q	12.3	12.3	12.3	17.7	0	17.7

**SPILLWAY OPERATION, STOPS (FT)**

BAY	1	2	3	4	5	6	7	8	9	10
STOPS	2	7	7	7	7	7	7	7	6	2

**SCALES IN FEET**



**ISOVEL PLOT**  
 8 DEFLECTORS  
 DISCHARGE: 172,300 CFS  
 TAILWATER: 351.0 FT

Plate 44

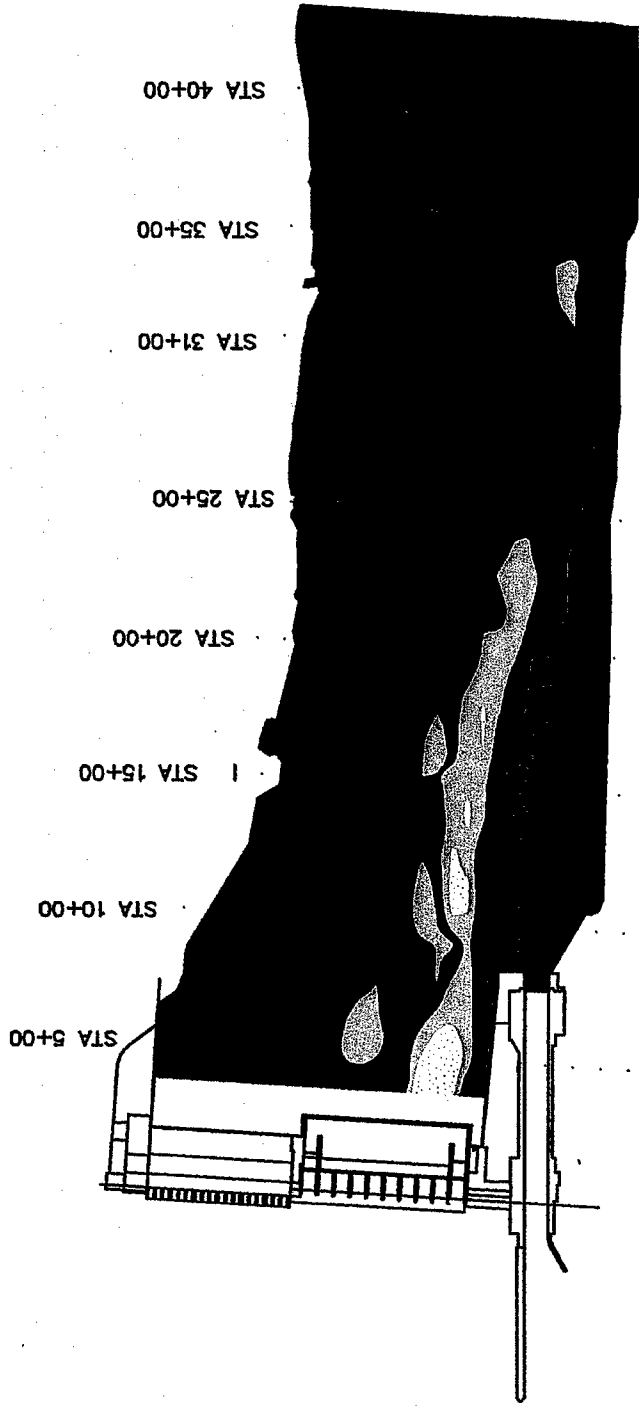

# ISOVEL PLOT

8 DEFLECTORS

DISCHARGE: 197,300 CFS  
TAILWATER: 352.5 FT

POWERHOUSE OPERATION, Q/UNITS, KCFS

UNIT	1	2	3	4	5	6
Q	12.3	12.3	12.3	17.7	0	17.7

SPILLWAY OPERATION, STOPS (FT)

BAY	1	2	3	4	5	6	7	8	9	10
STOPS	3	9	9	9	5	5	8	8	8	3

**OPERATING CONDITIONS**  
 POWERHOUSE DISCHARGE = 72.3 KCFS  
 SPILLWAY DISCHARGE = 125 KCFS  
 HEADPOOL ELEVATION = 439.0  
 TAILWATER ELEVATION = 352.5  
 DEFLECTORS LOCATED AT BAYS 2-9

**LEGEND**

- 0.0 - 2.5 fps
- 2.6 - 5.0 fps
- 5.1 - 7.5 fps
- 7.6 - 10.0 fps
- 10.1 - 12.5 fps
- 12.6 - 15.0 fps
- > 15.1 fps

**SCALES IN FEET**



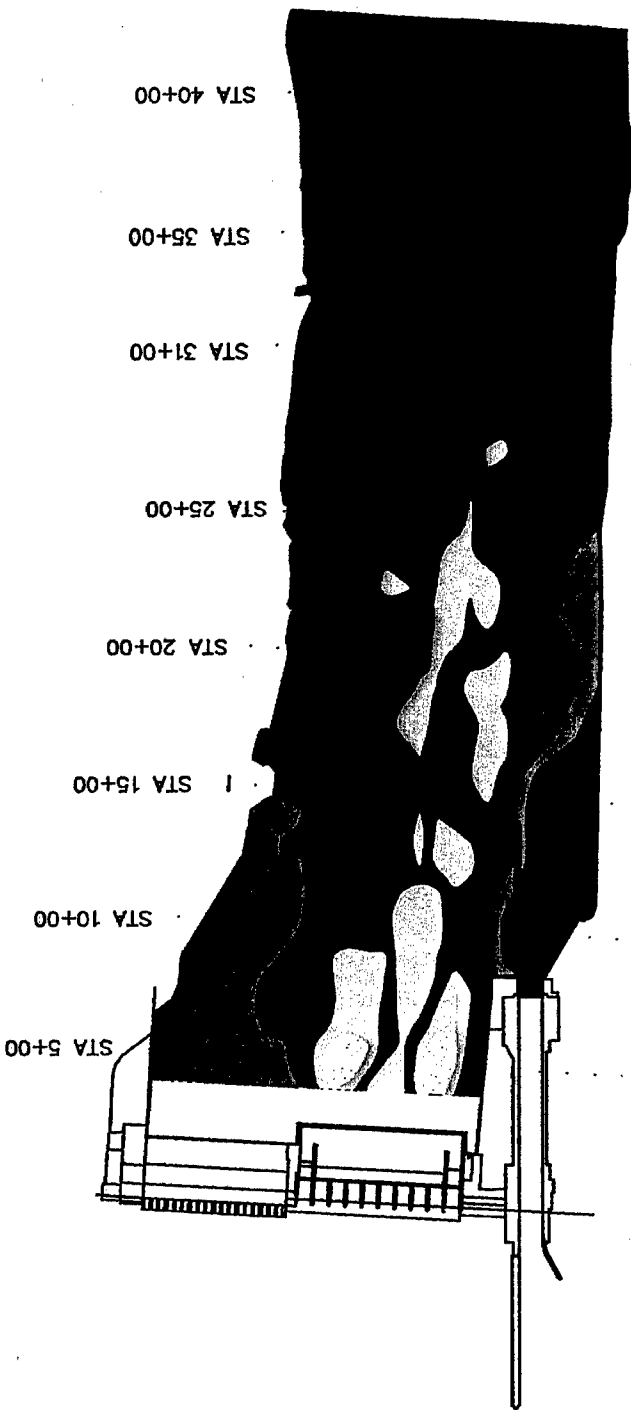

**OPERATING CONDITIONS**

POWERHOUSE DISCHARGE = 72.3 KCFS  
 SPILLWAY DISCHARGE = 150 KCFS  
 HEADPOOL ELEVATION = 439.0  
 TAILWATER ELEVATION = 353.7  
 DEFLECTORS LOCATED AT BAYS 2-8

**LEGEND**

- 0.0 - 2.5 fps
- 2.6 - 5.0 fps
- 5.0 - 7.5 fps
- 7.6 - 10.0 fps
- 10.0 - 12.5 fps
- 12.6 - 15.0 fps
- > 15.0 fps

**POWERHOUSE OPERATION, Q/UNITS, KCFS**

UNIT	1	2	3	4	5	6
Q	12.3	12.3	12.3	17.7	0	17.7

**SPILLWAY OPERATION, STOPS (FT)**

BAY	1	2	3	4	5	6	7	8	9	10
STOPS	4.6	10.1	10.1	10.1	10.1	10.1	10.1	10.1	10.1	4

**SCALES IN FEET**



**ISOVEL PLOT**  
 8 DEFLECTORS  
 DISCHARGE: 222,300 CFS  
 TAILWATER: 353.7 FT

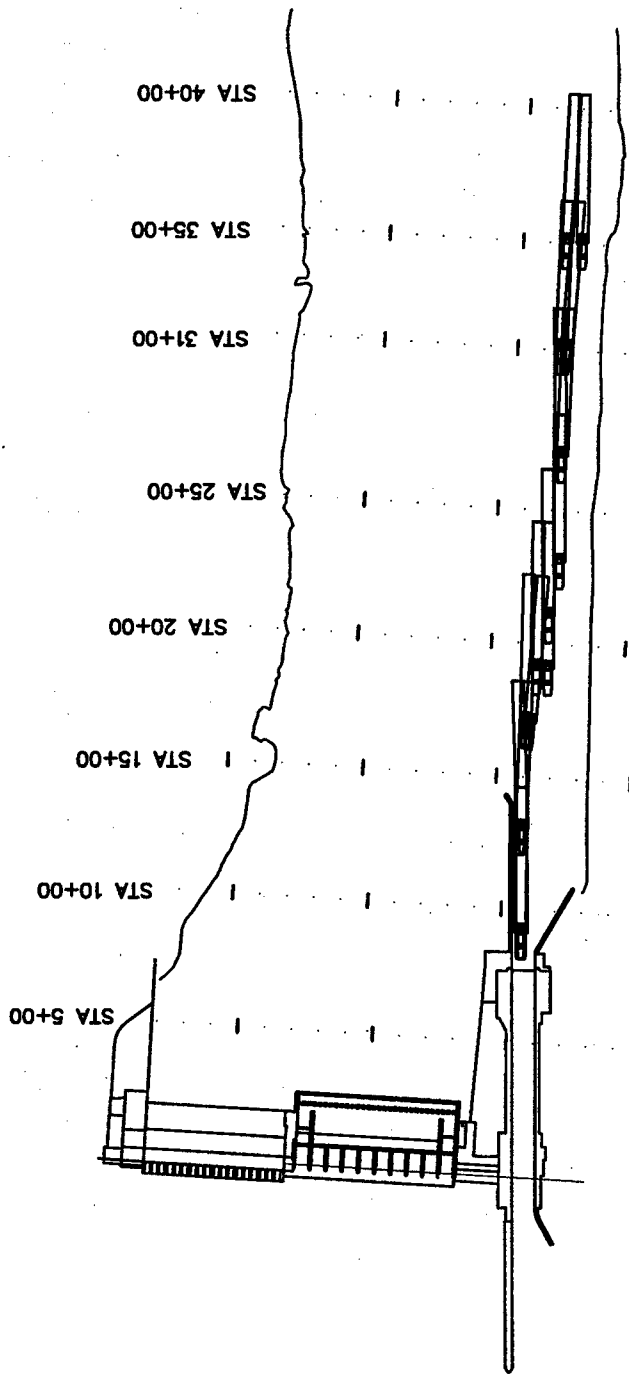

POWERHOUSE OPERATION, Q/UNITS, KCFS

UNIT	1	2	3	4	5	6
Q	12.3	12.3	12.3	17.7	0	17.7

SPILLWAY OPERATION, STOPS (FT)

BAY	1	2	3	4	5	6	7	8	9	10
STOPS	1	2	2	2	2	2	1	2	2	1.5

**OPERATING CONDITIONS**  
 POWERHOUSE DISCHARGE = 72.3 KCFS  
 SPILLWAY DISCHARGE = 30 KCFS  
 HEADPOOL ELEVATION = 439.0  
 TAILWATER ELEVATION = 346.5

**TOW PATHS**  
 DOWNBOUND  
 8 DEFLECTORS  
 2-BARGE FLOTILLA  
 (1 wide x 2 long)  
 DISCHARGE: 102,300 CFS  
 TAILWATER EL: 346.5 FT

**LEGEND**

2-BARGE TOW: 1 WIDE X 2 LONG  
 42 ft WIDE X 548 ft LONG X 13 ft DRAFT  
 WITH 100-ft PUSHER BOAT

**SCALES IN FEET**



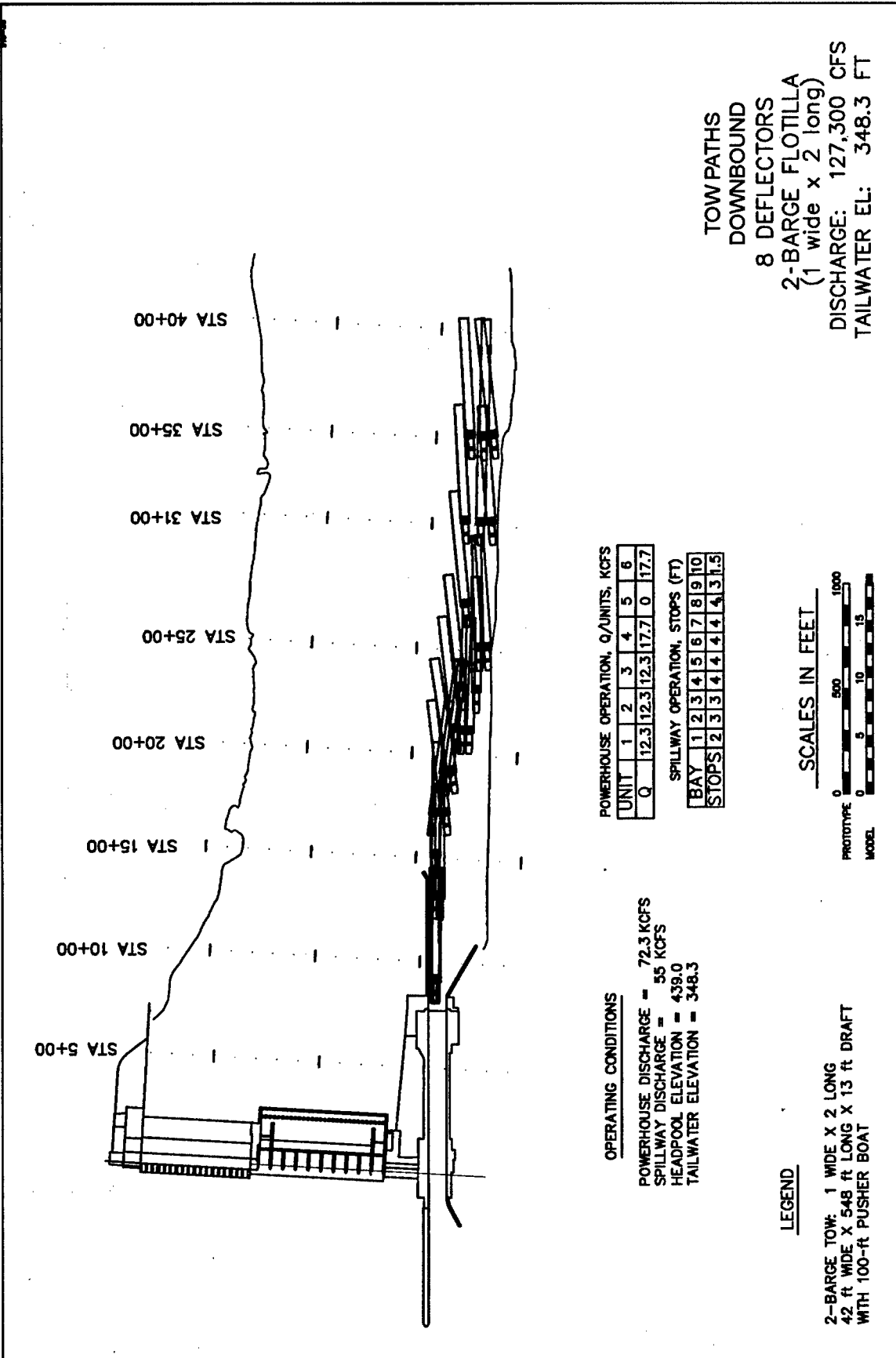

STA 5+00

STA 10+00

STA 15+00

STA 20+00

STA 25+00

STA 31+00

STA 35+00

STA 40+00

**OPERATING CONDITIONS**

POWERHOUSE DISCHARGE = 72.3 KCFS  
 SPILLWAY DISCHARGE = 55 KCFS  
 HEADPOOL ELEVATION = 439.0  
 TAILWATER ELEVATION = 348.3

**POWERHOUSE OPERATION, Q/UNITS, KCFS**

UNIT	1	2	3	4	5	6
Q	12.3	12.3	12.3	17.7	0	17.7

**SPILLWAY OPERATION, STOPS (FT)**

BAY	1	2	3	4	5	6	7	8	9	10
STOPS	2	3	3	4	4	4	4	4	4	3

**LEGEND**

2-BARGE TOW: 1 WIDE X 2 LONG  
 42 ft WIDE X 548 ft LONG X 13 ft DRAFT  
 WITH 100-ft PUSHER BOAT

TOW PATHS  
 DOWNBOUND  
 8 DEFLECTORS  
 2-BARGE FLOTILLA  
 (1 wide x 2 long)  
 DISCHARGE: 127,300 CFS  
 TAILWATER EL: 348.3 FT

**SCALES IN FEET**



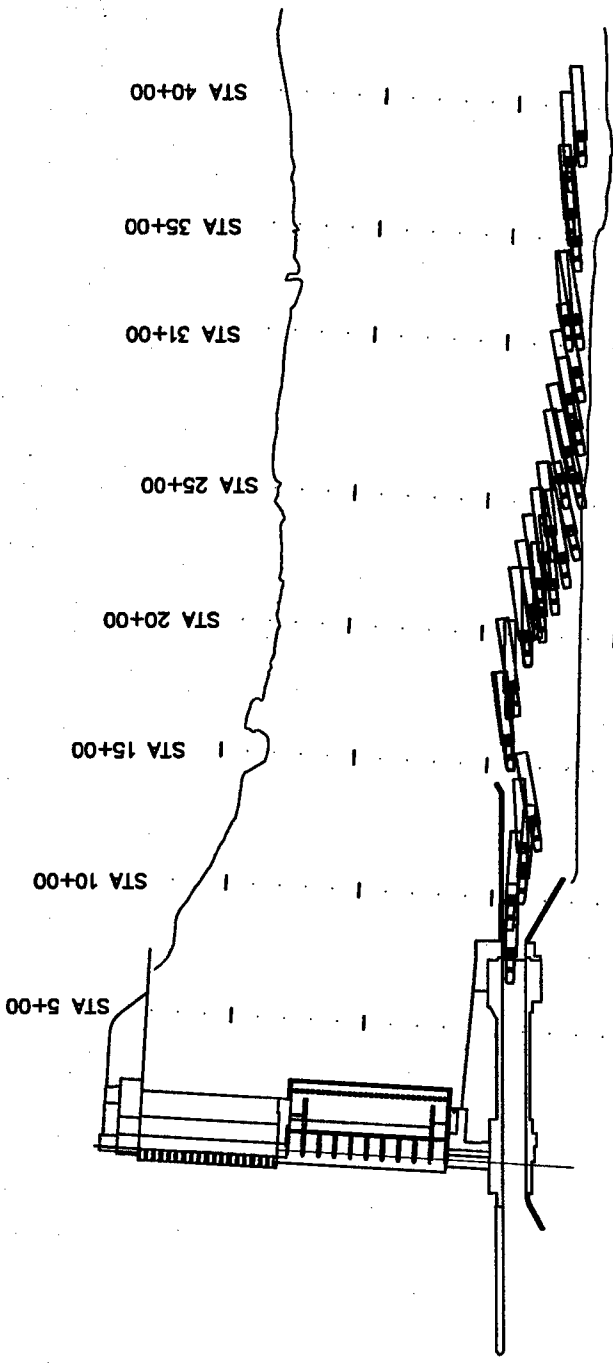

**OPERATING CONDITIONS**

POWERHOUSE DISCHARGE = 72.3 KCFS  
 SPILLWAY DISCHARGE = 100 KCFS  
 HEADPOOL ELEVATION = 439.0  
 TAILWATER ELEVATION = 351.0

**POWERHOUSE OPERATION, Q/UNITS, KCFS**

UNIT	1	2	3	4	5	6
Q	12.3	12.3	12.3	17.7	0	17.7

**SPILLWAY OPERATION, STOPS (FT)**

BAY	1	2	3	4	5	6	7	8	9	10
STOPS	2	7	7	7	7	7	7	7	7	6

**LEGEND**

1-BARGE TOW: 1 WIDE X 1 LONG  
 42 ft WIDE X 274 ft LONG X 13 ft DRAFT  
 WITH 100-ft PUSHER BOAT

**TOW PATHS**  
**DOWNBOUND**  
 8 DEFLECTORS  
 1-BARGE FLOTILLA  
 (1 wide x 1 long)  
 DISCHARGE: 172,300 CFS  
 TAILWATER EL: 351.0 FT

**SCALES IN FEET**



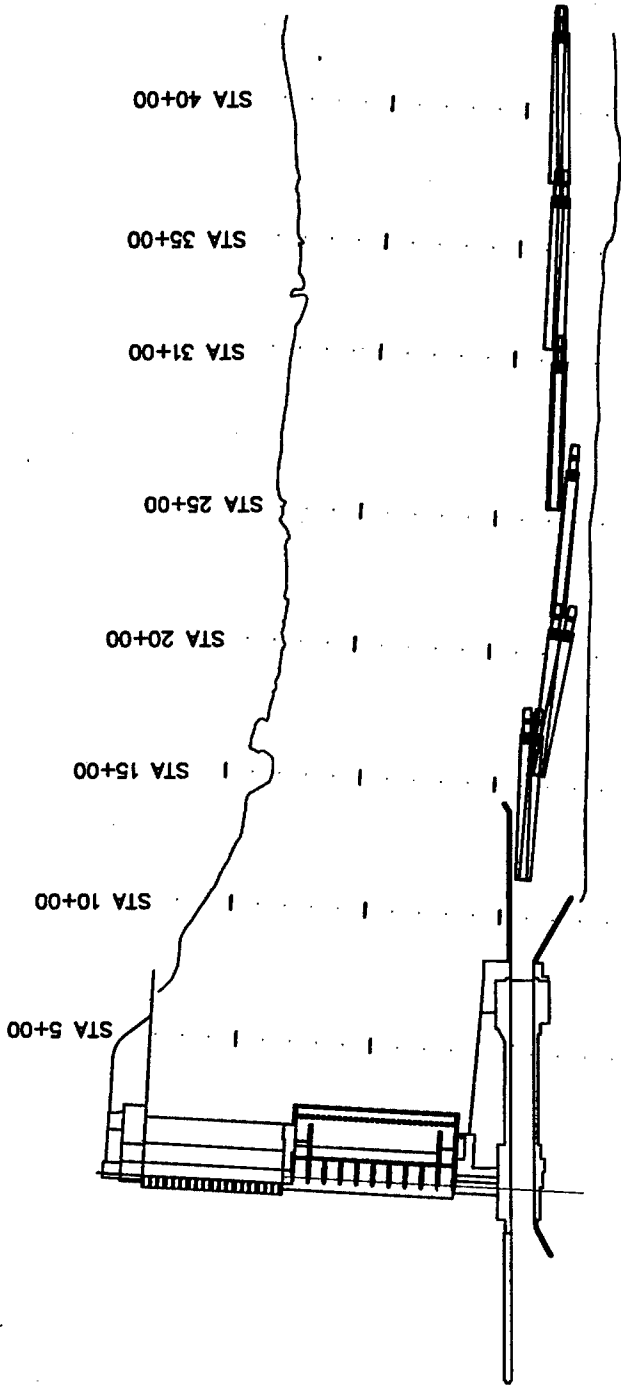

OPERATING CONDITIONS

POWERHOUSE DISCHARGE = 72.3 KCFS  
 SPILLWAY DISCHARGE = 30 KCFS  
 HEADPOOL ELEVATION = 439.0  
 TAILWATER ELEVATION = 346.5

POWERHOUSE OPERATION, Q/UNITS, KCFS

UNIT	1	2	3	4	5	6
Q	12.3	12.3	12.3	17.7	0	17.7

SPILLWAY OPERATION, STOPS (FT)

BAY	1	2	3	4	5	6	7	8	9	10
STOPS	1	2	2	2	2	1	2	1	2	1.5

LEGEND

2-BARGE TOW: 1 WIDE X 2 LONG  
 42 ft WIDE X 548 ft LONG X 13 ft DRAFT  
 WITH 100-ft PUSHER BOAT

TOWPATHS  
 UPBOUND  
 8 DEFLECTORS  
 2-BARGE FLOTILLA  
 (1 wide x 2 long)  
 DISCHARGE: 102,300 CFS  
 TAILWATER EL: 346.5 FT

SCALES IN FEET



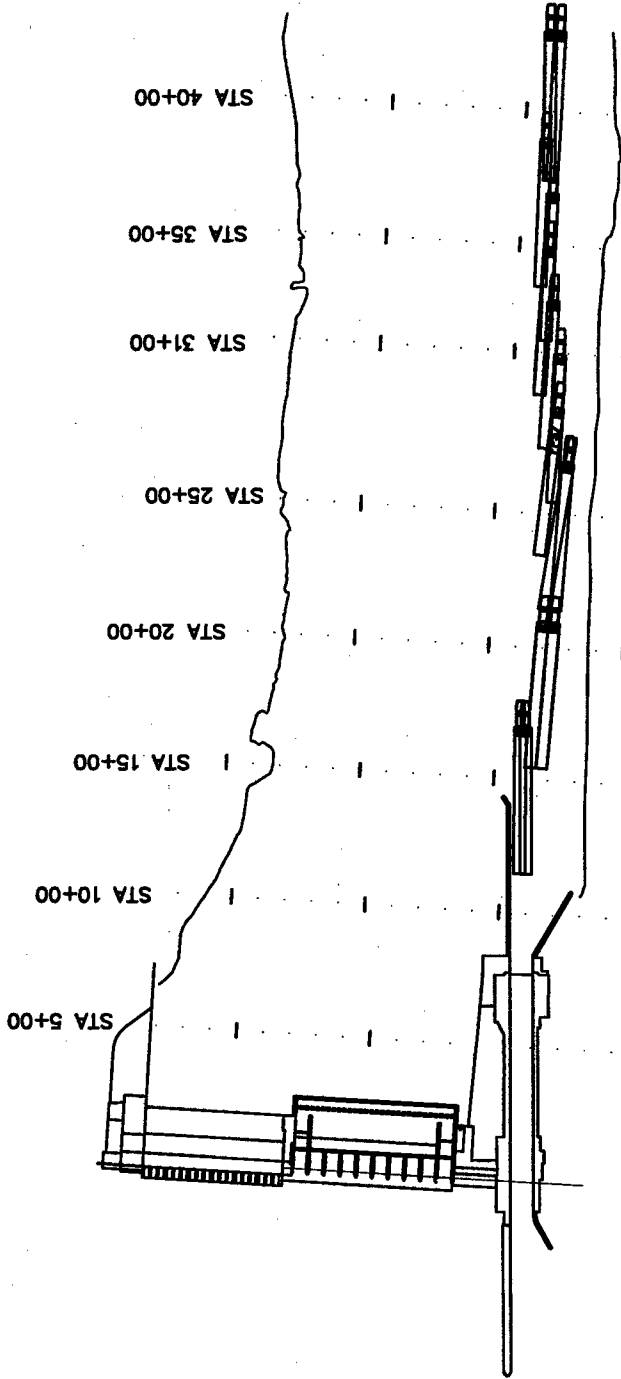

**OPERATING CONDITIONS**

POWERHOUSE DISCHARGE = 72.3 KCFS  
 SPILLWAY DISCHARGE = 30 KCFS  
 HEADPOOL ELEVATION = 439.0  
 TAILWATER ELEVATION = 348.3

**POWERHOUSE OPERATION, Q/UNITS, KCFS**

UNIT	1	2	3	4	5	6
Q	12.3	12.3	12.3	17.7	0	17.7

**SPILLWAY OPERATION, STOPS (FT)**

BAY	1	2	3	4	5	6	7	8	9	10
STOPS	2	3	3	4	4	4	4	4	4	3

**LEGEND**

2-BARGE TOW: 1 WIDE X 2 LONG  
 42 ft WIDE X 548 ft LONG X 13 ft DRAFT  
 WITH 100-ft PUSHER BOAT

TOWPATHS  
 UPBOUND  
 8 DEFLECTORS  
 2-BARGE FLOTILLA  
 (1 wide x 2 long)  
 DISCHARGE: 127,300 CFS  
 TAILWATER EL: 348.3 FT

**SCALES IN FEET**



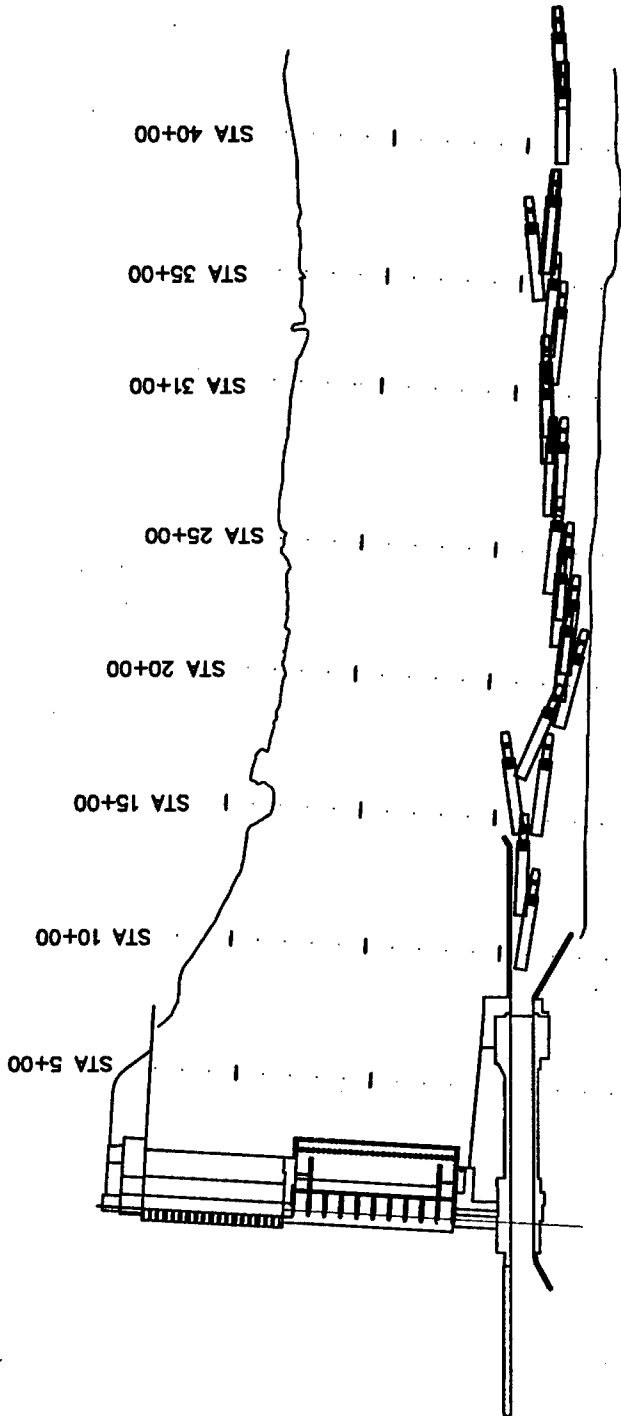

**OPERATING CONDITIONS**  
 POWERHOUSE DISCHARGE = 72.3 KCFS  
 SPILLWAY DISCHARGE = 100 KCFS  
 HEADPOOL ELEVATION = 439.0  
 TAILWATER ELEVATION = 351.0

**POWERHOUSE OPERATION, Q/UNITS, KCFS**

UNIT	1	2	3	4	5	6
Q	12.3	12.3	12.3	17.7	0	17.7

**SPILLWAY OPERATION, STOPS (FT)**

BAY	1	2	3	4	5	6	7	8	9	10
STOPS	2	7	7	7	7	7	7	7	7	2

**LEGEND**  
 1-BARGE TOW: 1 WIDE X 1 LONG  
 42 ft WIDE X 274 ft LONG X 13 ft DRAFT  
 WITH 100-ft PUSHER BOAT



**TOW PATHS UPBOUND**  
 8 DEFLECTORS  
 1-BARGE FLOTILLA  
 (1 wide x 1 long)  
 DISCHARGE: 172,300 CFS  
 TAILWATER EL: 351.0 FT

Plate 52

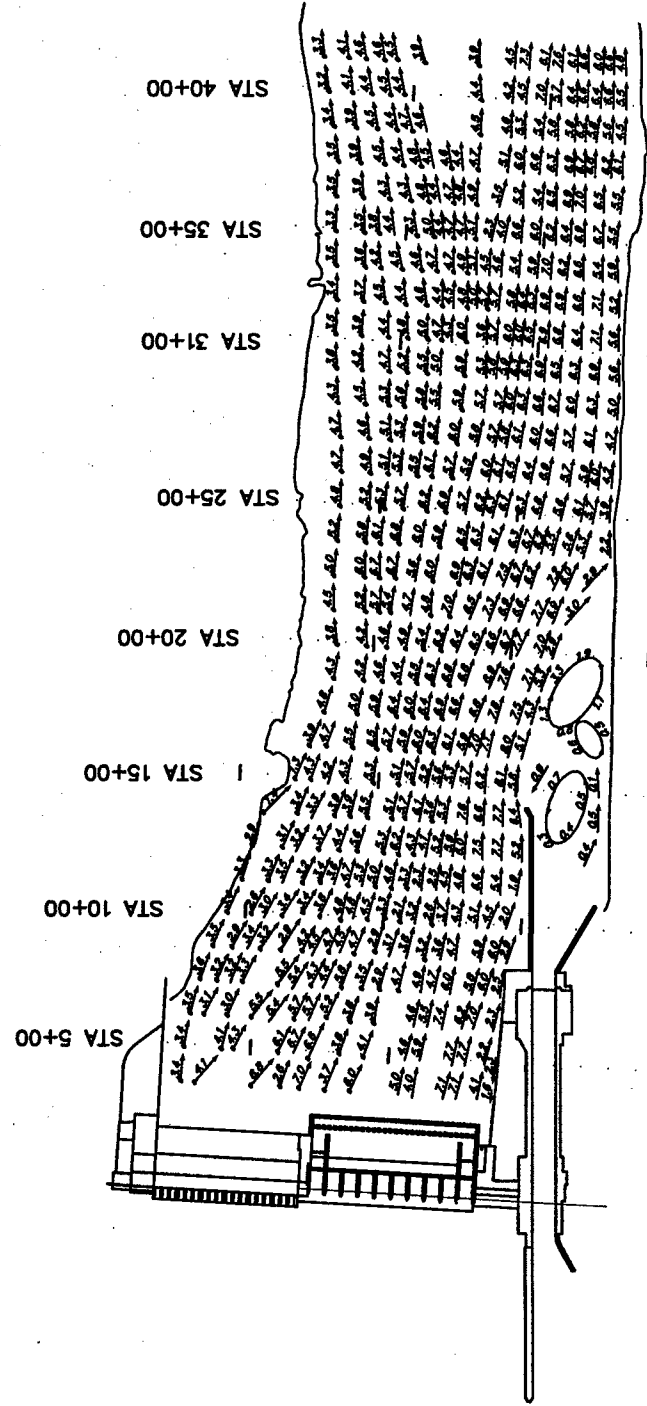

**VELOCITIES AND  
CURRENT DIRECTIONS**  
10 DEFLECTORS  
DISCHARGE: 102,300 CFS  
TAILWATER: 346.5 FT

POWERHOUSE OPERATION, Q/UNITS, KCFS

UNIT	1	2	3	4	5	6
Q	12.3	12.3	12.3	17.7	0	17.7

SPILLWAY OPERATION, STOPS (FT)

BAY	1	2	3	4	5	6	7	8	9	10
STOPS	1	2	2	2	2	2	1	2	2	1.5

**OPERATING CONDITIONS**

POWERHOUSE DISCHARGE = 72.3 KCFS  
 SPILLWAY DISCHARGE = 30 KCFS  
 HEADPOOL ELEVATION = 439.0  
 TAILWATER ELEVATION = 346.5

**LEGEND**

VELOCITY IN FEET PER SECOND (13.0 ft DRAFT)  
 VELOCITY IN FEET PER SECOND (7.0 ft DRAFT)

NOTE: VELOCITIES AND CURRENT DIRECTION  
 OBTAINED WITH FLOATS SUBMERGED TO  
 DRAFT OF 13.0 ft and 7.0 ft

**SCALES IN FEET**



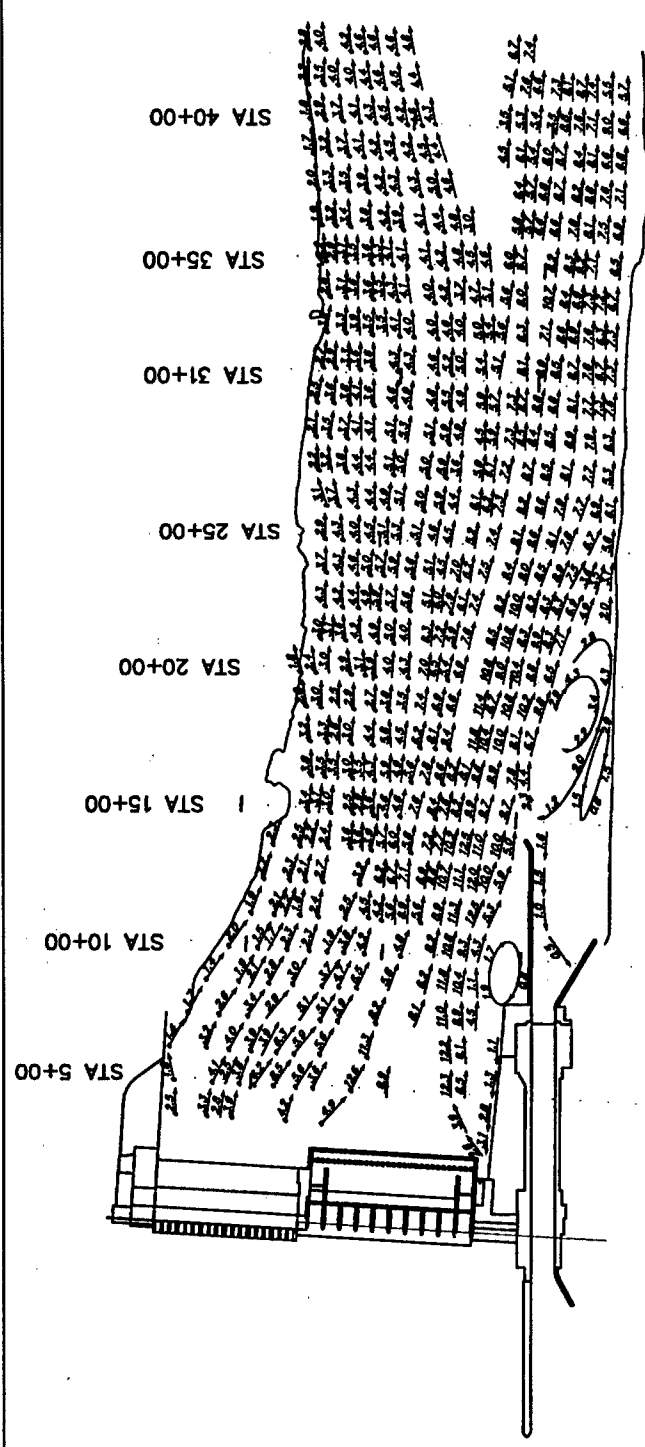

**VELOCITIES AND CURRENT DIRECTIONS**  
 10 DEFLECTORS  
 DISCHARGE: 117,300 CFS  
 TAILWATER: 347.7 FT

**POWERHOUSE OPERATION, Q/UNITS, KCFS**

UNIT	1	2	3	4	5	6
Q	12.3	12.3	12.3	17.7	0	17.7

**SPILLWAY OPERATION, STOPS (FT)**

BAY	1	2	3	4	5	6	7	8	9	10
STOPS	2	3	3	3	3	3	3	3	2	1.5

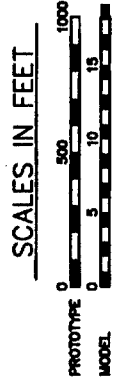

**OPERATING CONDITIONS**  
 POWERHOUSE DISCHARGE = 72.3 KCFS  
 SPILLWAY DISCHARGE = 45 KCFS  
 HEADPOOL ELEVATION = 439.0  
 TAILWATER ELEVATION = 347.7

**LEGEND**  
 VELOCITY IN FEET PER SECOND (13.0 ft DRAFT)  
 VELOCITY IN FEET PER SECOND (7.0 ft DRAFT)  
 NOTE: VELOCITIES AND CURRENT DIRECTION OBTAINED WITH FLOATS SUBMERGED TO DRAFT OF 13.0 ft and 7.0 ft

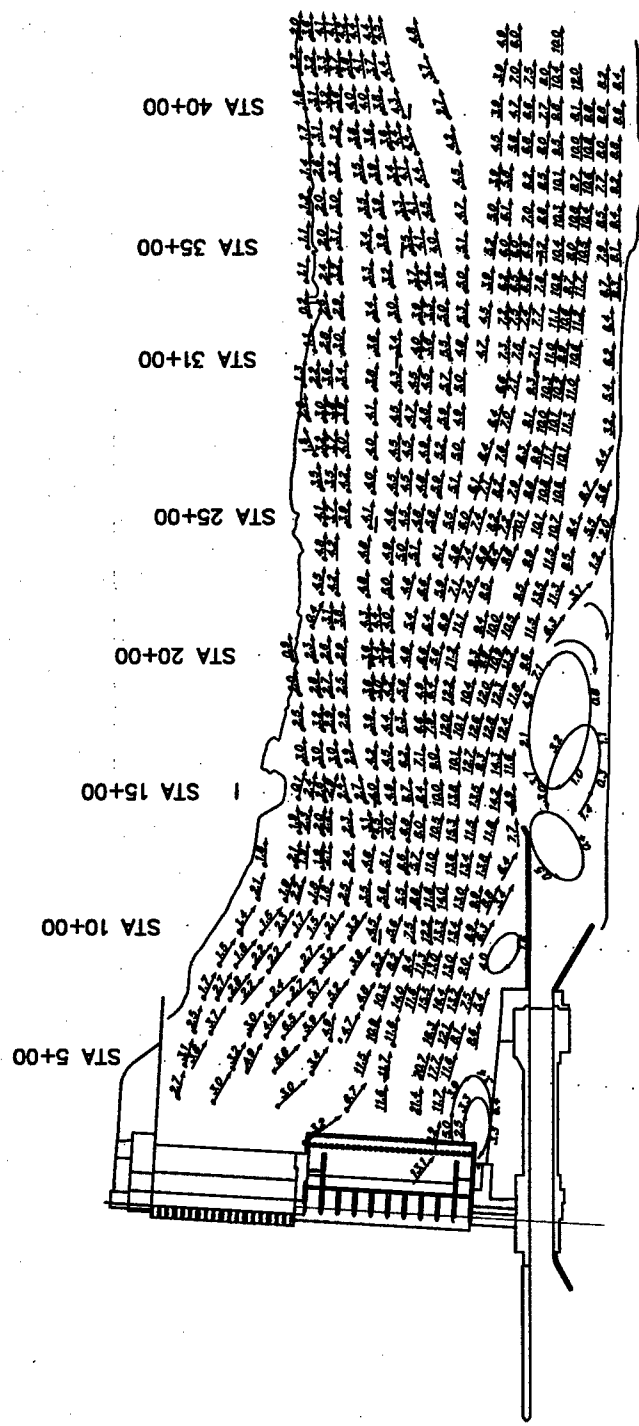

**VELOCITIES AND CURRENT DIRECTIONS**  
**10 DEFLECTORS**  
 DISCHARGE: 127,300 CFS  
 TAILWATER: 348.3 FT

**POWERHOUSE OPERATION, Q/UNITS, KCFS**

UNIT	1	2	3	4	5	6
Q	12.3	12.3	12.3	17.7	0	17.7

**SPILLWAY OPERATION, STOPS (FT)**

BAY	1	2	3	4	5	6	7	8	9	10
STOPS	2	3	3	4	4	4	4	4	4	3

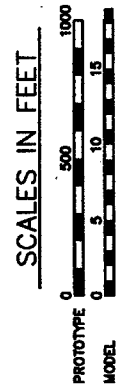

**OPERATING CONDITIONS**  
 POWERHOUSE DISCHARGE = 72.3 KCFS  
 SPILLWAY DISCHARGE = 55 KCFS  
 HEADPOOL ELEVATION = 439.0  
 TAILWATER ELEVATION = 348.3

**LEGEND**  
 VELOCITY IN FEET PER SECOND (13.0 ft DRAFT)  
 VELOCITY IN FEET PER SECOND (7.0 ft DRAFT)  
 NOTE : VELOCITIES AND CURRENT DIRECTION  
 OBTAINED WITH FLOATS SUBMERGED TO  
 DRAFT OF 13.0 ft and 7.0 ft

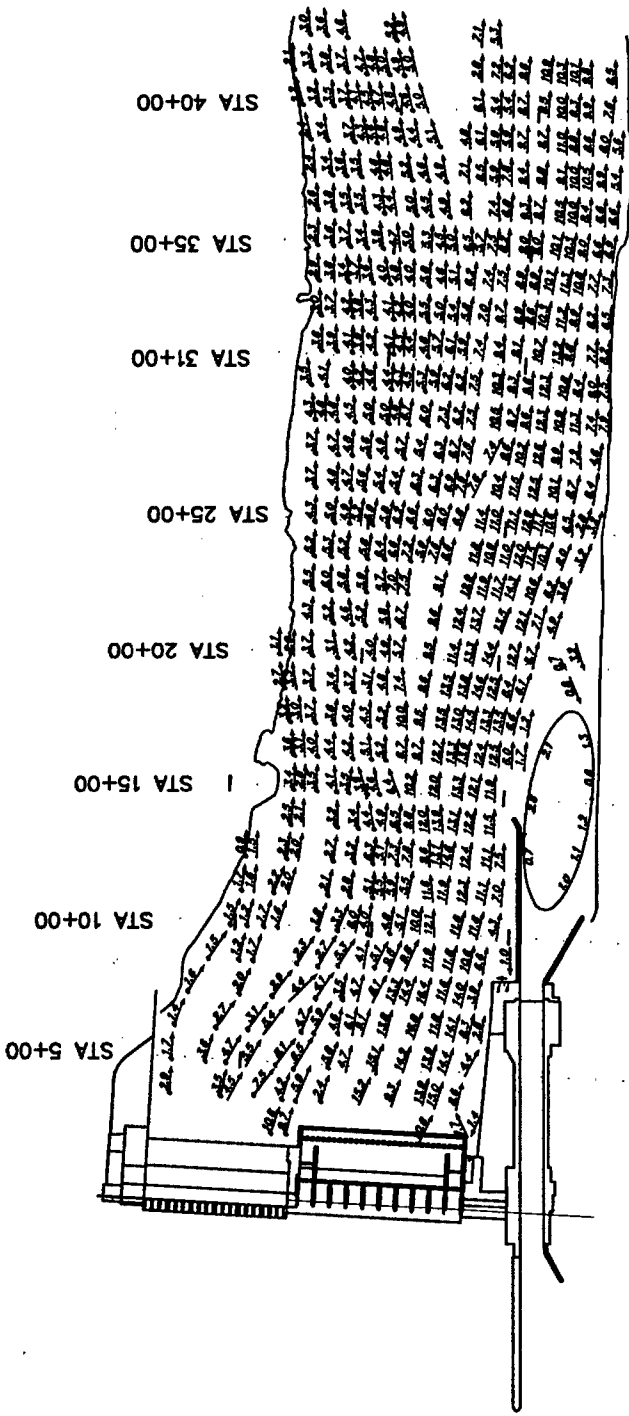

**VELOCITIES AND  
CURRENT DIRECTIONS**  
10 DEFLECTORS  
DISCHARGE: 147,300 CFS  
TAILWATER: 349.7 FT

**POWERHOUSE OPERATION, Q/UNITS, KCFS**

UNIT	1	2	3	4	5	6
Q	12.3	12.3	12.3	17.7	0	17.7

**SPILLWAY OPERATION, STOPS (FT)**

BAY	1	2	3	4	5	6	7	8	9	10
STOPS	2	6	5	5	5	5	5	5	5	1.5

**OPERATING CONDITIONS**  
POWERHOUSE DISCHARGE = 72.3 KCFS  
SPILLWAY DISCHARGE = 75 KCFS  
HEADPOOL ELEVATION = 439.0  
TAILWATER ELEVATION = 349.7

**LEGEND**

VELOCITY IN FEET PER SECOND (13.0 ft DRAFT)  
VELOCITY IN FEET PER SECOND (7.0 ft DRAFT)

**NOTE :** VELOCITIES AND CURRENT DIRECTION  
OBTAINED WITH FLOATS SUBMERGED TO  
DRAFT OF 13.0 ft and 7.0 ft

**SCALES IN FEET**



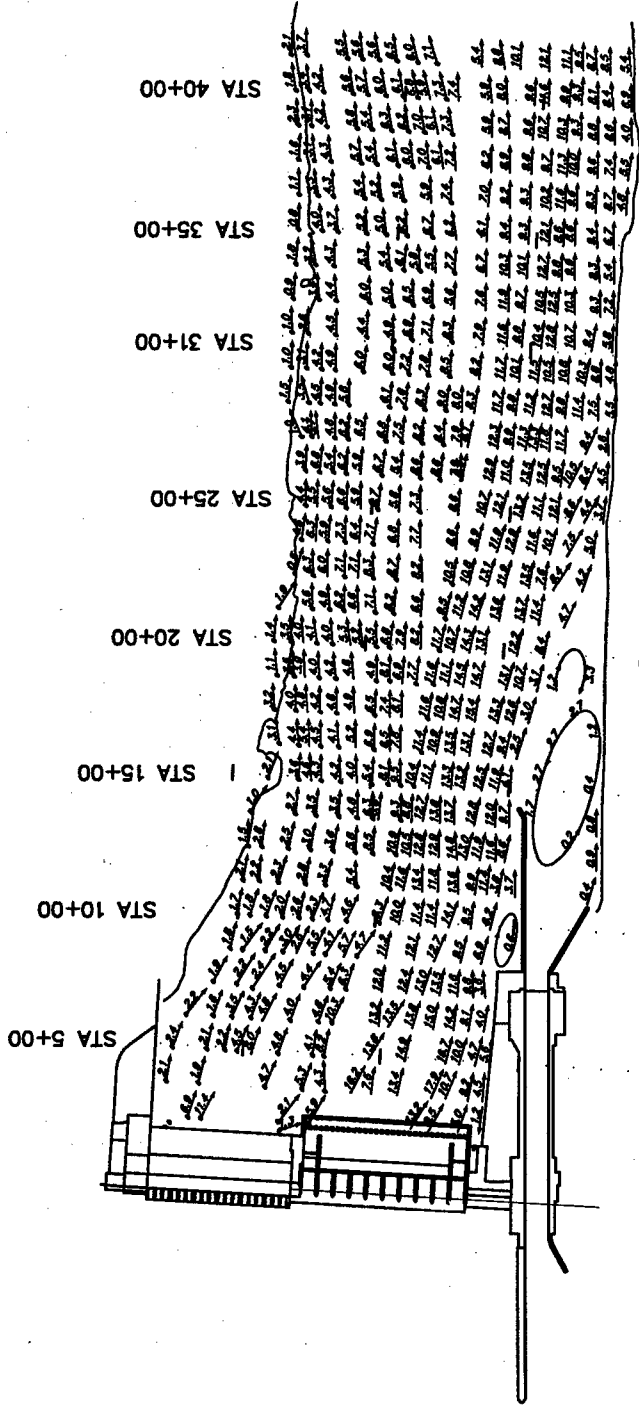

**OPERATING CONDITIONS**

POWERHOUSE DISCHARGE = 72.3 KCFS  
 SPILLWAY DISCHARGE = 100 KCFS  
 HEADPOOL ELEVATION = 439.0  
 TAILWATER ELEVATION = 351.0

**LEGEND**

VELOCITY IN FEET PER SECOND (13.0 ft DRAFT)  
 VELOCITY IN FEET PER SECOND (7.0 ft DRAFT)

NOTE :  
 VELOCITIES AND CURRENT DIRECTION  
 OBTAINED WITH FLOATS SUBMERGED TO  
 DRAFT OF 13.0 ft and 7.0 ft

**POWERHOUSE OPERATION, Q/UNITS, KCFS**

UNIT	1	2	3	4	5	6
Q	12.3	12.3	12.3	17.7	0	17.7

**SPILLWAY OPERATION, STOPS (FT)**

BAY	1	2	3	4	5	6	7	8	9	10
STOPS	2	7	7	7	7	7	7	7	7	2

**SCALES IN FEET**



**VELOCITIES AND  
 CURRENT DIRECTIONS  
 10 DEFLECTORS  
 DISCHARGE: 172,300 CFS  
 TAILWATER: 351.0 FT**

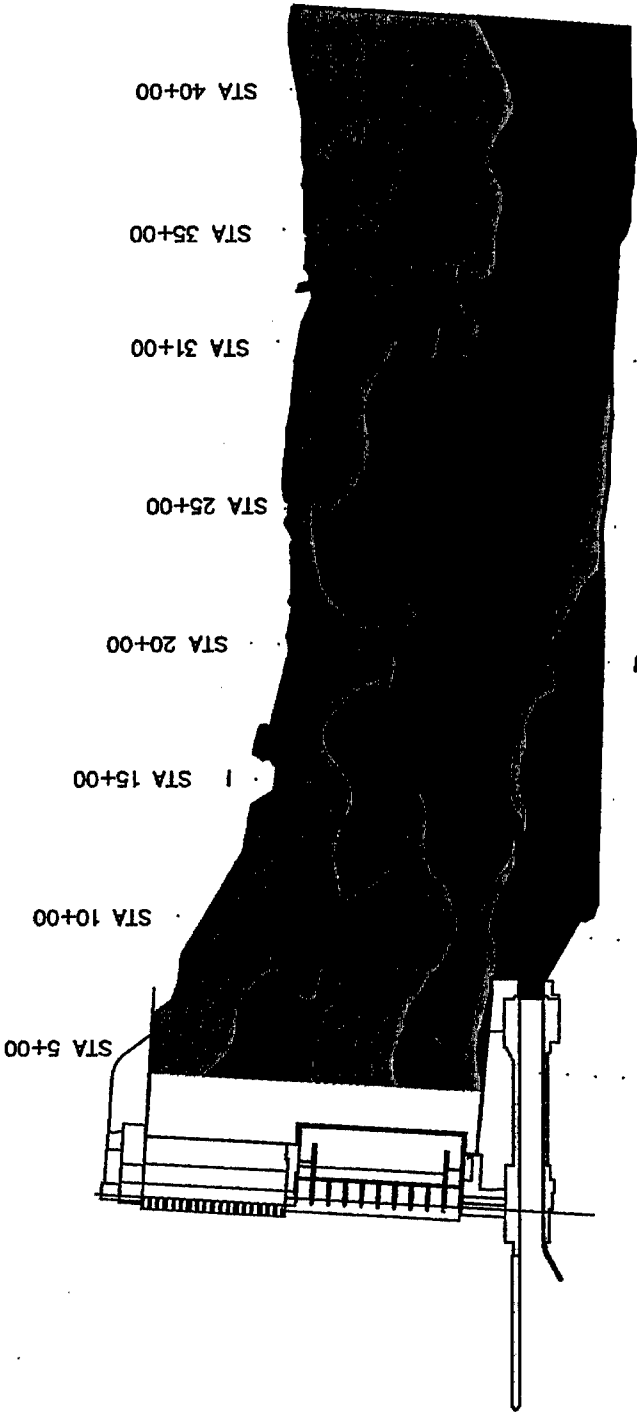

**OPERATING CONDITIONS**  
 POWERHOUSE DISCHARGE = 72.3 KCFS  
 SPILLWAY DISCHARGE = 30 KCFS  
 HEADPOOL ELEVATION = 439.0  
 TAILWATER ELEVATION = 346.5

**LEGEND**

[Thick black bar]	0.0 - 2.5 fps
[Medium-thick black bar]	2.6 - 5.0 fps
[Thin black bar]	5.1 - 7.5 fps
[Dotted pattern bar]	7.6 - 10.0 fps
[Horizontal line pattern bar]	10.1 - 12.5 fps
[Vertical line pattern bar]	12.6 - 15.0 fps
[White bar]	> 15.1 fps

**POWERHOUSE OPERATION, Q/UNITS, KCFS**

UNIT	1	2	3	4	5	6
Q	12.3	12.3	12.3	17.7	0	17.7

**SPILLWAY OPERATION, STOPS (FT)**

BAY	1	2	3	4	5	6	7	8	9	10
STOPS	1	2	2	2	2	1	2	2	2	1.5

**SCALES IN FEET**



**ISOVEL PLOT**  
 10 DEFLECTORS  
 DISCHARGE: 102,300 CFS  
 TAILWATER: 346.5 FT

Plate 58

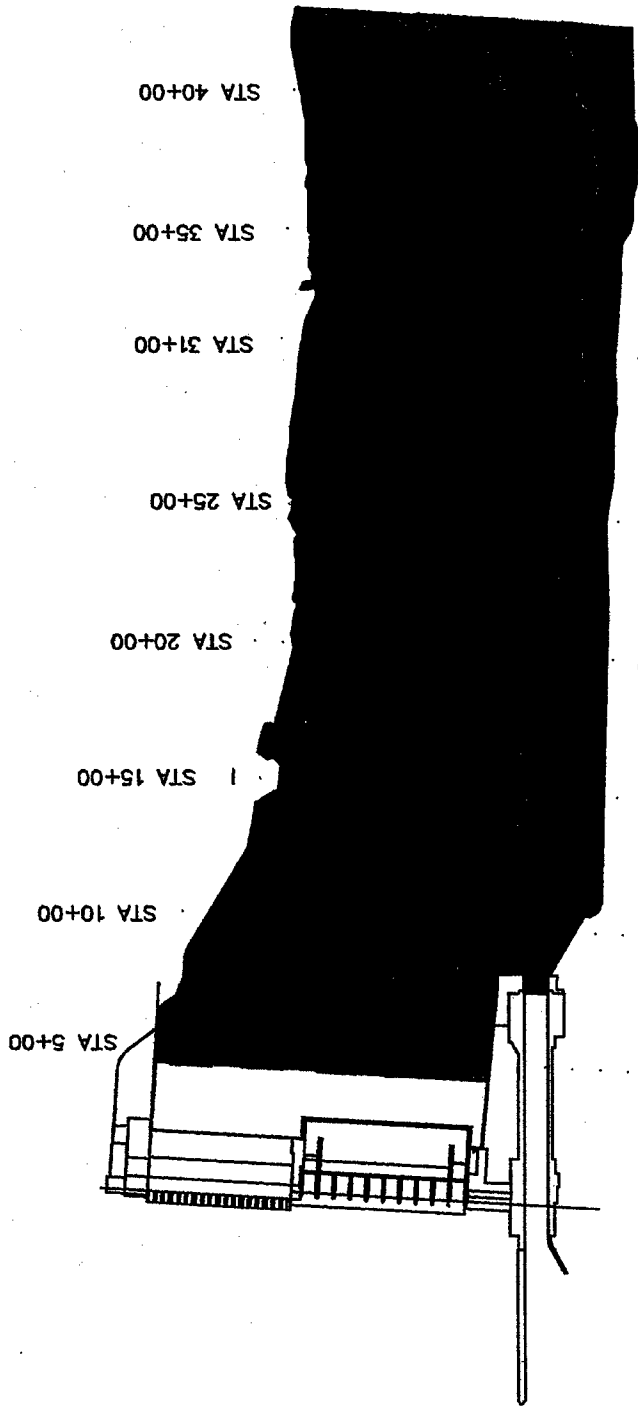

# ISOVEL PLOT

10 DEFLECTORS  
 DISCHARGE: 117,300 CFS  
 TAILWATER: 347.7 FT

POWERHOUSE OPERATION, Q/UNITS, KCFS

UNIT	1	2	3	4	5	6
Q	12.3	12.3	12.3	17.7	0	17.7

SPILLWAY OPERATION, STOPS (FT)

BAY	1	2	3	4	5	6	7	8	9	10
STOPS	2	3	3	3	3	3	3	3	2	1.5

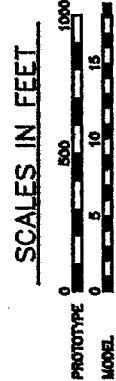

**OPERATING CONDITIONS**  
 POWERHOUSE DISCHARGE = 72.3 KCFS  
 SPILLWAY DISCHARGE = 30 KCFS  
 HEADPOOL ELEVATION = 439.0  
 TAILWATER ELEVATION = 347.7

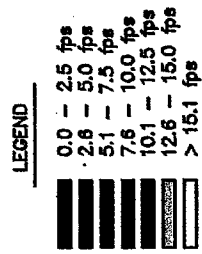

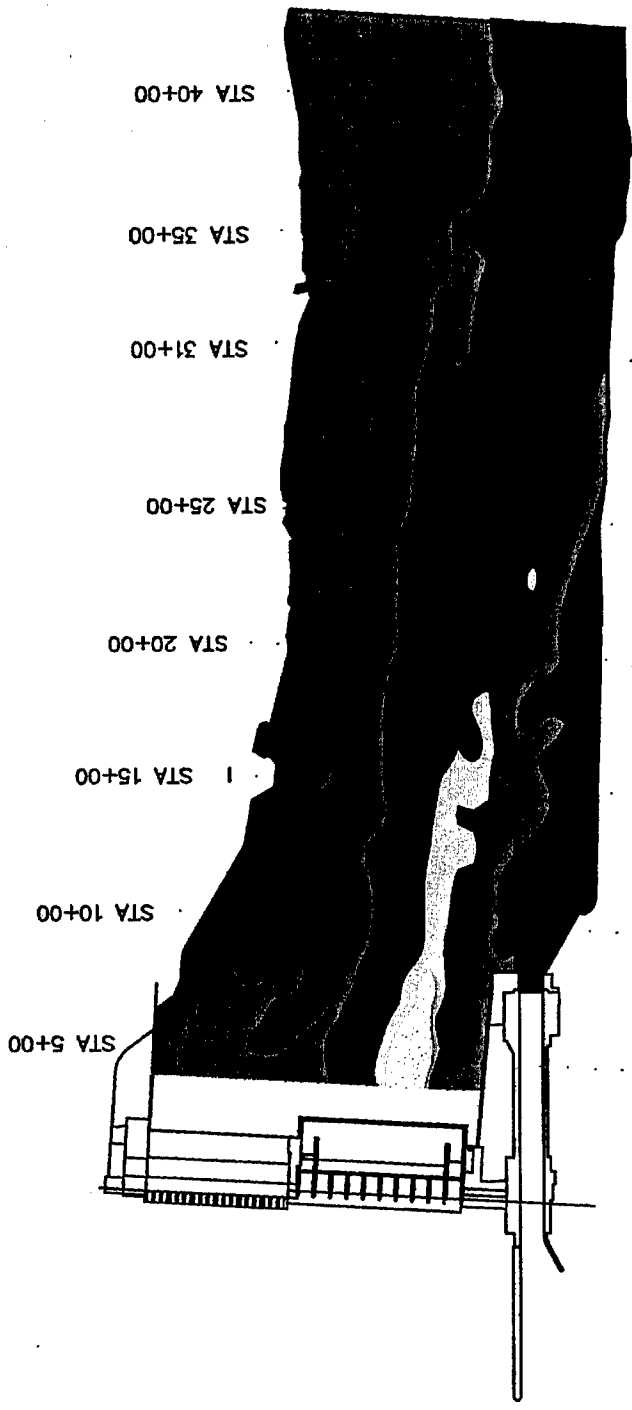

STA 5+00  
 STA 10+00  
 STA 15+00  
 STA 20+00  
 STA 25+00  
 STA 31+00  
 STA 35+00  
 STA 40+00

**OPERATING CONDITIONS**  
 POWERHOUSE DISCHARGE = 72.3 KCFS  
 SPILLWAY DISCHARGE = 85 KCFS  
 HEADPOOL ELEVATION = 439.0  
 TAILWATER ELEVATION = 348.3

**LEGEND**

[Hatched pattern]	0.0 - 2.5 fps
[Hatched pattern]	2.6 - 5.0 fps
[Hatched pattern]	5.1 - 7.5 fps
[Hatched pattern]	7.6 - 10.0 fps
[Hatched pattern]	10.1 - 12.5 fps
[Hatched pattern]	12.6 - 15.0 fps
[Hatched pattern]	> 15.1 fps

**POWERHOUSE OPERATION, Q/UNITS, KCFS**

UNIT	1	2	3	4	5	6
Q	12.3	12.3	12.3	17.7	0	17.7

**SPILLWAY OPERATION, STOPS (FT)**

BAY	1	2	3	4	5	6	7	8	9	10
STOPS	2	4	4	4	4	4	4	4	4	1.6

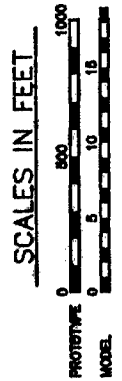

**ISOVEL PLOT**  
 10 DEFLECTORS  
 DISCHARGE: 127,300 CFS  
 TAILWATER: 348.3 FT

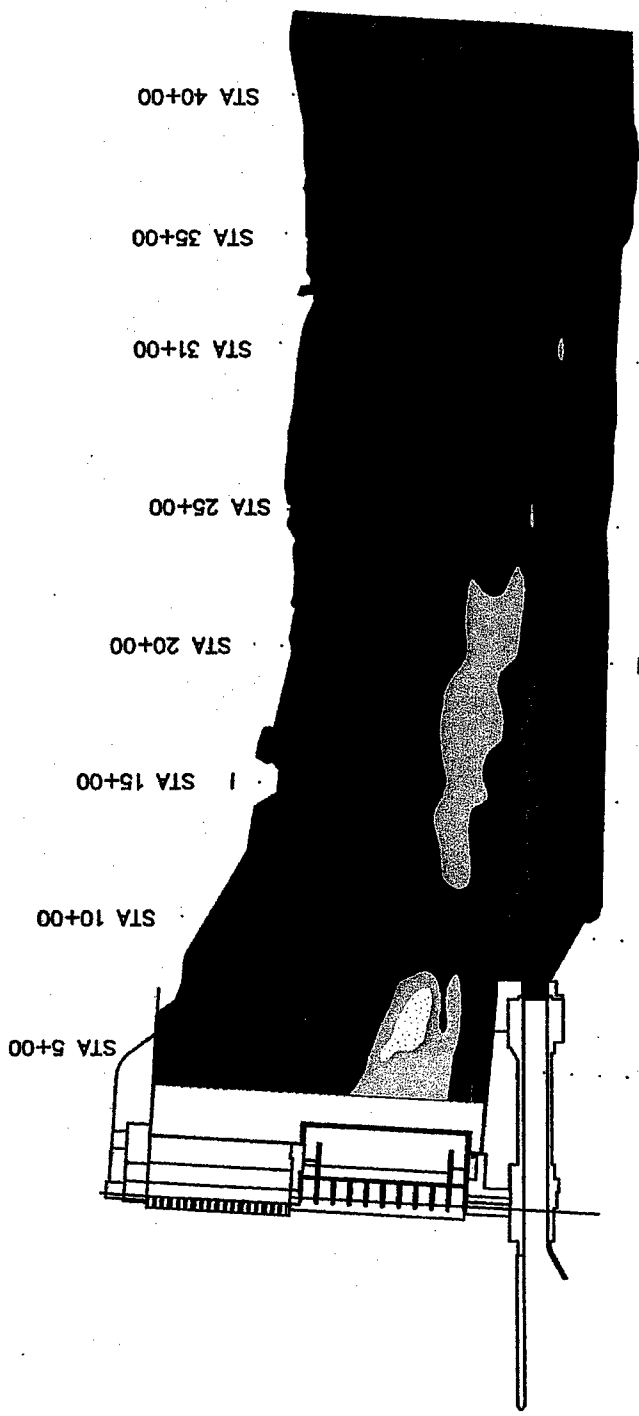

STA 5+00  
STA 10+00  
STA 15+00  
STA 20+00  
STA 25+00  
STA 31+00  
STA 35+00  
STA 40+00

**OPERATING CONDITIONS**  
 POWERHOUSE DISCHARGE = 72.3 KCFS  
 SPILLWAY DISCHARGE = 75 KCFS  
 HEADPOOL ELEVATION = 439.0  
 TAILWATER ELEVATION = 349.7

**POWERHOUSE OPERATION, Q/UNITS, KCFS**

UNIT	1	2	3	4	5	6
Q	12.3	12.3	12.3	17.7	0	17.7

**SPILLWAY OPERATION, STOPS (FT)**

BAY	1	2	3	4	5	6	7	8	9	10
STOPS	2	6	5	5	5	5	5	5	5	1.3

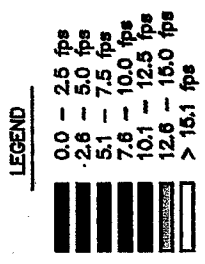

**ISOVEL PLOT**  
 10 DEFLECTORS  
 DISCHARGE: 147,300 CFS  
 TAILWATER: 349.7 FT

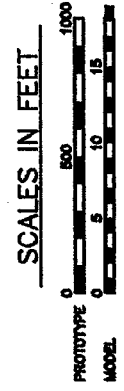

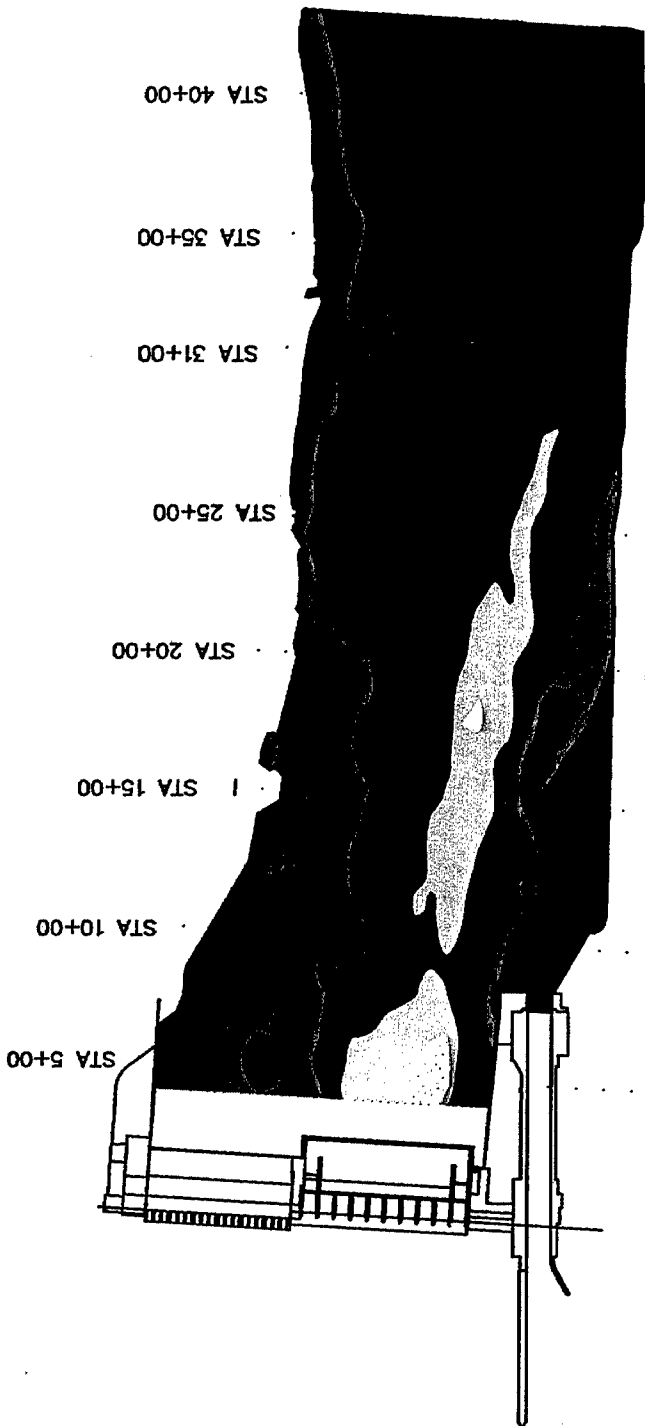

# ISOVEL PLOT

10 DEFLECTORS

DISCHARGE: 172,300 CFS

TAILWATER: 351.0 FT

**POWERHOUSE OPERATION, Q/UNITS, KCFS**

UNIT	1	2	3	4	5	6
Q	12.3	12.3	12.3	17.7	0	17.7

**SPILLWAY OPERATION, STOPS (FT)**

BAY	1	2	3	4	5	6	7	8	9	10
STOPS	2	7	7	7	7	7	7	6	2	

**OPERATING CONDITIONS**

POWERHOUSE DISCHARGE = 72.3 KCFS  
 SPILLWAY DISCHARGE = 100 KCFS  
 HEADPOOL ELEVATION = 351.0  
 TAILWATER ELEVATION = 347.7

**LEGEND**

0.0 - 2.5 fps
2.6 - 5.0 fps
5.1 - 7.5 fps
7.6 - 10.0 fps
10.1 - 12.5 fps
12.6 - 15.0 fps
> 15.1 fps

**SCALES IN FEET**



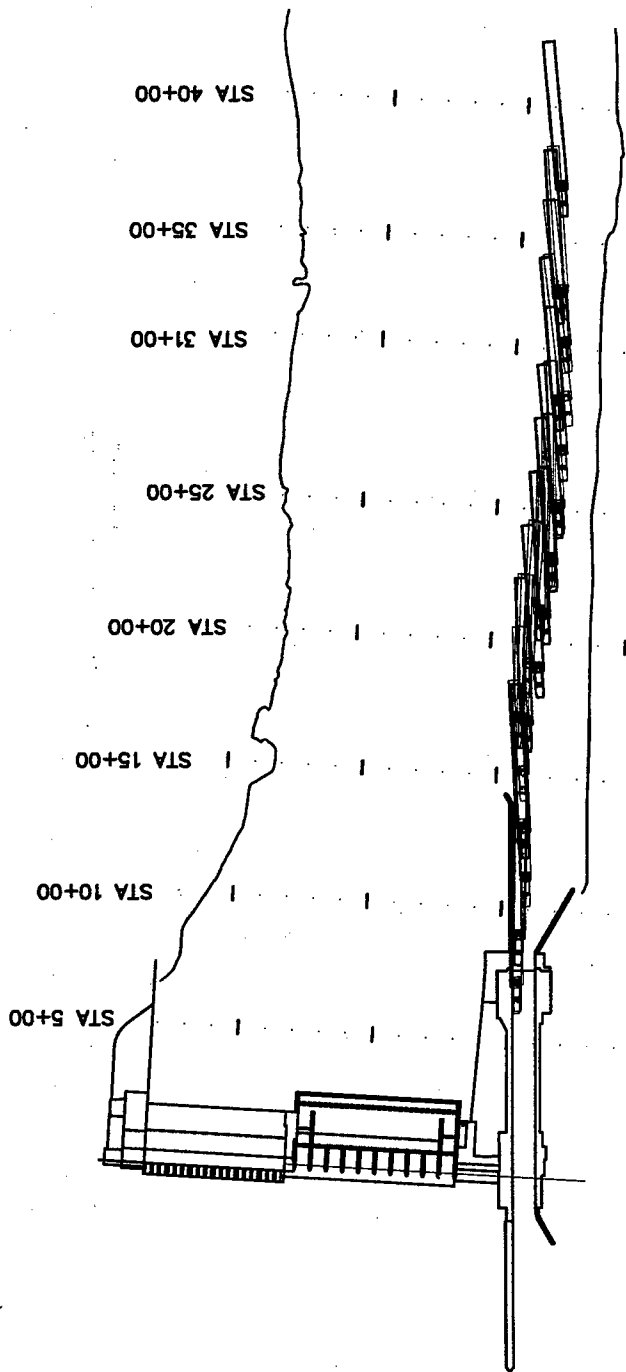

OPERATING CONDITIONS

POWERHOUSE DISCHARGE = 72.3 KCFS  
 SPILLWAY DISCHARGE = 30 KCFS  
 HEADPOOL ELEVATION = 434.9  
 TAILWATER ELEVATION = 346.5

POWERHOUSE OPERATION, Q/UNITS, KCFS

UNIT	1	2	3	4	5	6
Q	12.3	12.3	12.3	17.7	0	17.7

SPILLWAY OPERATION, STOPS (FT)

BAY	1	2	3	4	5	6	7	8	9	10
STOPS	1	2	2	2	2	2	1	2	2	1.5

LEGEND

2-BARGE TOW: 1 WIDE X 2 LONG  
 42 ft WIDE X 548 ft LONG X 13 ft DRAFT  
 WITH 100-ft PUSHER BOAT

TOW PATHS  
 DOWNBOUND  
 10 DEFLECTORS  
 2-BARGE FLOTILLA  
 (1 wide x 2 long)  
 DISCHARGE: 102,300 CFS  
 TAILWATER EL: 346.5 FT

SCALES IN FEET



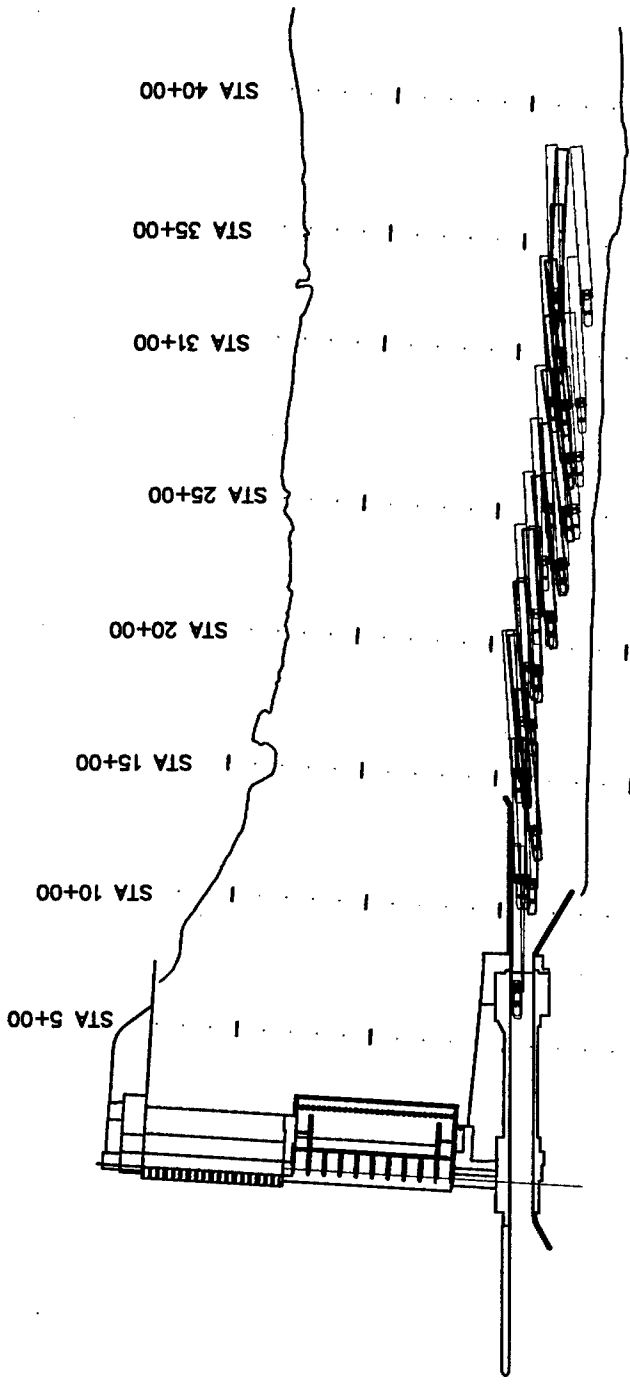

**OPERATING CONDITIONS**

POWERHOUSE DISCHARGE = 72.3 KCFS  
 SPILLWAY DISCHARGE = 55 KCFS  
 HEADPOOL ELEVATION = 439.0  
 TAILWATER ELEVATION = 348.3

**POWERHOUSE OPERATION, Q/UNITS, KCFS**

UNIT	1	2	3	4	5	6
Q	12.3	12.3	12.3	17.7	0	17.7

**SPILLWAY OPERATION, STOPS (FT)**

BAY	1	2	3	4	5	6	7	8	9	10
STOPS	2	3	3	4	4	4	4	4	3	1.5

**LEGEND**

2-BARGE TOW: 1 WIDE X 2 LONG  
 42 ft WIDE X 548 ft LONG X 13 ft DRAFT  
 WITH 100-ft PUSHER BOAT

TOW PATHS  
 DOWNBOUND  
 10 DEFLECTORS  
 2-BARGE FLOTILLA  
 (1 wide x 2 long)  
 DISCHARGE: 127,300 CFS  
 TAILWATER EL: 348.3 FT

**SCALES IN FEET**



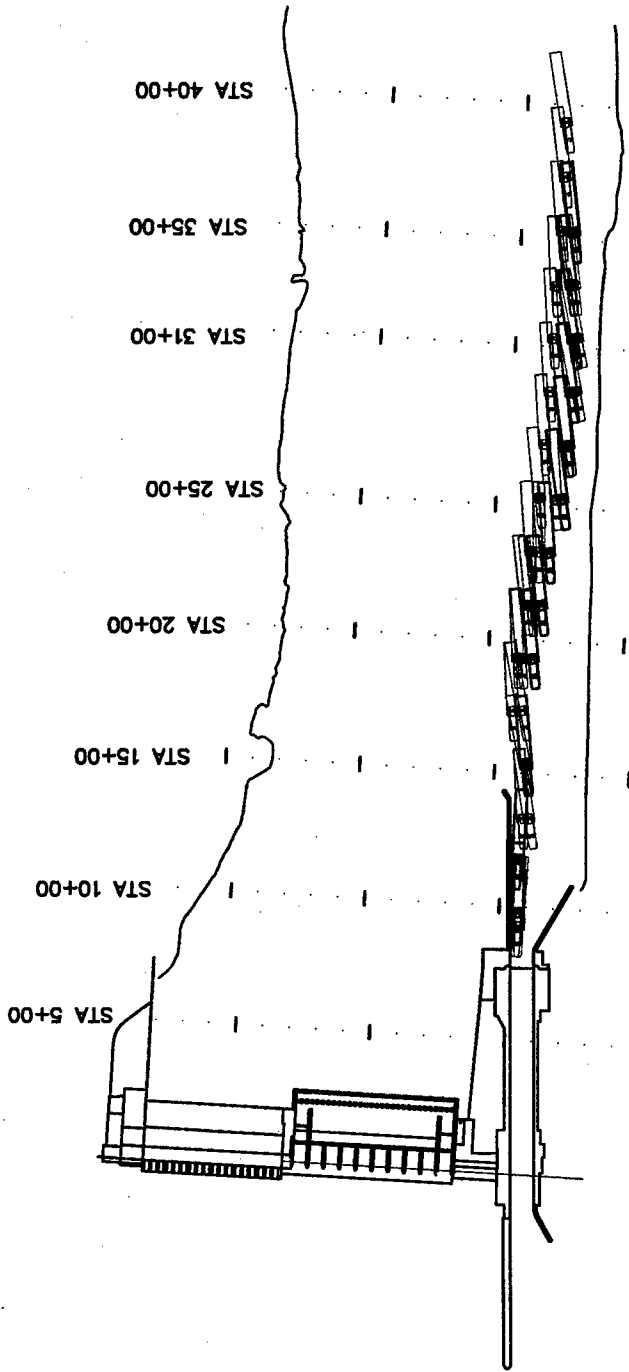

**OPERATING CONDITIONS**

POWERHOUSE DISCHARGE = 72.3 KCFS  
 SPILLWAY DISCHARGE = 100 KCFS  
 HEADPOOL ELEVATION = 439.0  
 TAILWATER ELEVATION = 351.0

**LEGEND**

1-BARGE TOW: 1 WIDE X 1 LONG  
 42 ft WIDE X 274 ft LONG X 13 ft DRAFT  
 WITH 100-ft PUSHER BOAT

**POWERHOUSE OPERATION, Q/UNITS, KCFS**

UNIT	1	2	3	4	5	6
Q	12.3	12.3	12.3	17.7	0	17.7

**SPILLWAY OPERATION, STOPS (FT)**

BAY	1	2	3	4	5	6	7	8	9	10
STOPS	2	7	7	7	7	7	7	7	6	2

**TOWPATHS**  
 DOWNBOUND  
 10 DEFLECTORS  
 1-BARGE FLOTILLA  
 (1 wide x 1 long)  
 DISCHARGE: 172,300 CFS  
 TAILWATER EL: 351.0 FT

**SCALES IN FEET**



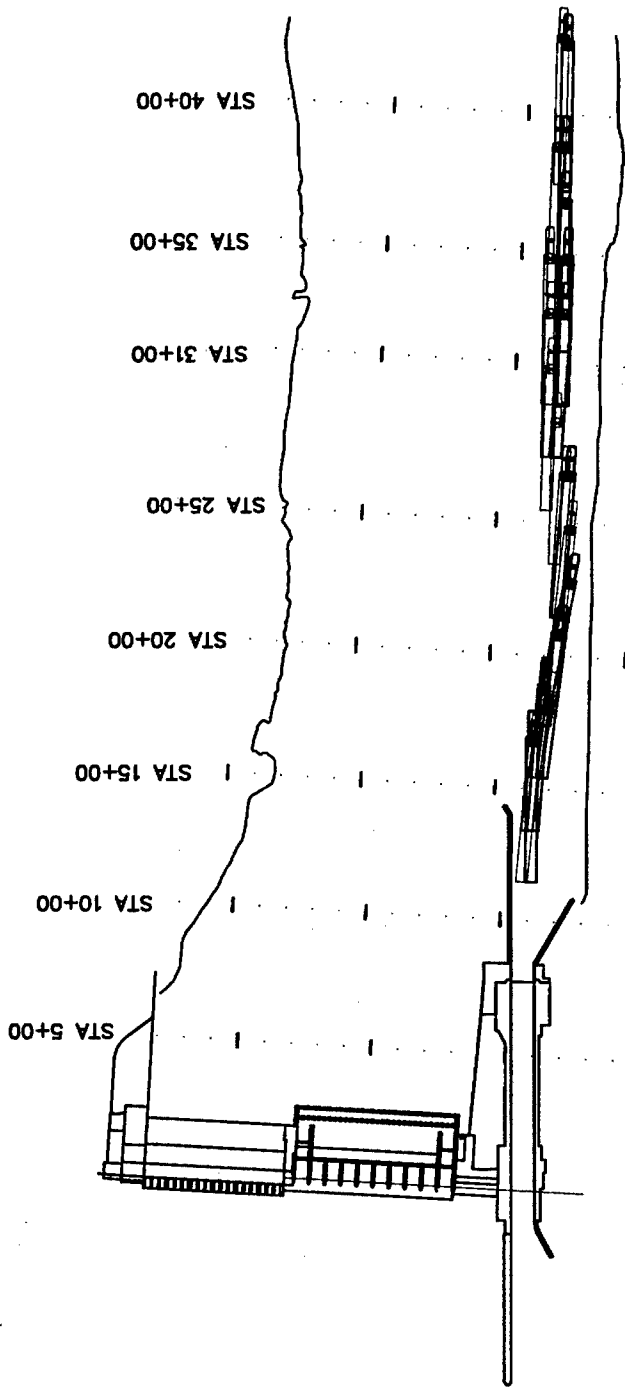

OPERATING CONDITIONS

POWERHOUSE DISCHARGE = 72.3 KCFS  
 SPILLWAY DISCHARGE = 30 KCFS  
 HEADPOOL ELEVATION = 439.0  
 TAILWATER ELEVATION = 346.5

POWERHOUSE OPERATION, Q/UNITS, KCFS

UNIT	1	2	3	4	5	6
Q	12.3	12.3	12.3	17.7	0	17.7

SPILLWAY OPERATION, STOPS (FT)

BAY	1	2	3	4	5	6	7	8	9	10
STOPS	1	2	2	2	2	1	2	2	1.5	

LEGEND

2-BARGE TOW: 1 WIDE X 2 LONG  
 42 FT WIDE X 548 FT LONG X 13 FT DRAFT  
 WITH 100-ft PUSHER BOAT

SCALES IN FEET



TOWPATHS  
 UPBOUND  
 10 DEFLECTORS  
 2-BARGE FLOTILLA  
 (1 wide x 2 long)  
 DISCHARGE: 102,300 CFS  
 TAILWATER EL: 346.5 FT

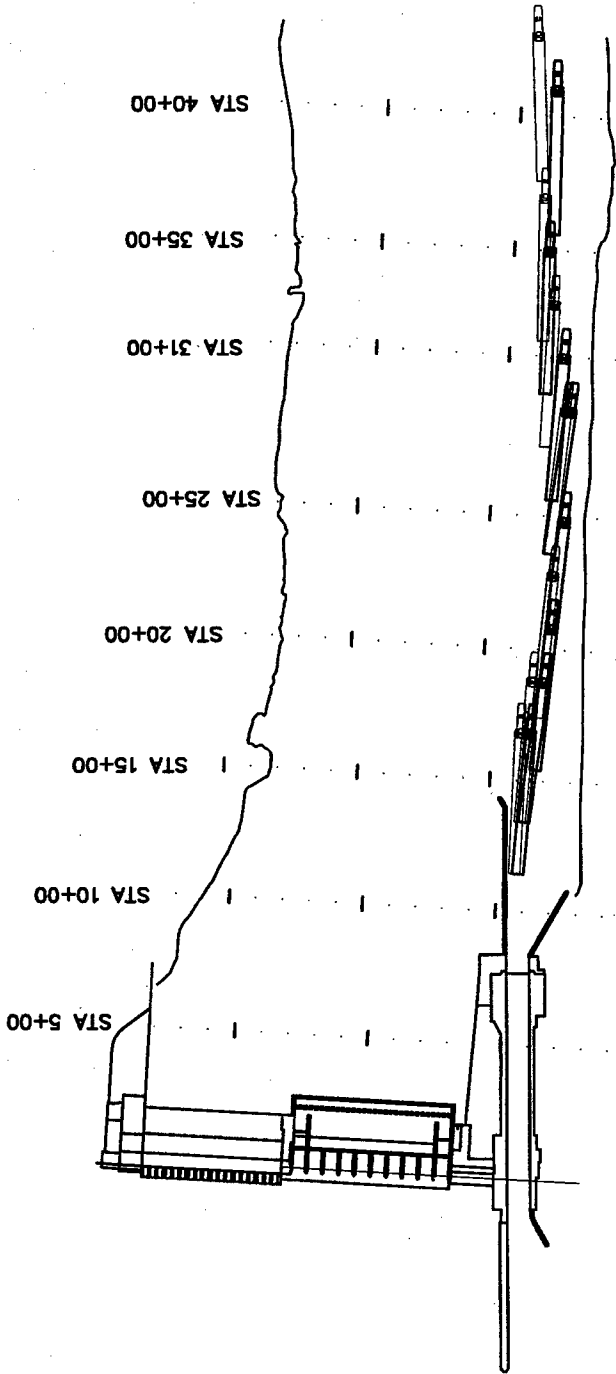

**OPERATING CONDITIONS**  
 POWERHOUSE DISCHARGE = 72.3 KCFS  
 SPILLWAY DISCHARGE = 55 KCFS  
 HEADPOOL ELEVATION = 439.0  
 TAILWATER ELEVATION = 348.3

**POWERHOUSE OPERATION, Q/UNITS, KCFS**

UNIT	1	2	3	4	5	6
Q	12.3	12.3	12.3	17.7	0	17.7

**SPILLWAY OPERATION, STOPS (FT)**

BAY	1	2	3	4	5	6	7	8	9	10
STOPS	2	3	3	4	4	4	4	4	4	3

**LEGEND**  
 2-BARGE TOW: 1 WIDE X 2 LONG  
 42 ft WIDE X 548 ft LONG X 13 ft DRAFT  
 WITH 100-ft PUSHER BOAT

**SCALES IN FEET**



TOWPATHS  
 UPBOUND  
 10 DEFLECTORS  
 2-BARGE FLOTILLA  
 (1 wide x 2 long)  
 DISCHARGE: 127,300 CFS  
 TAILWATER EL: 348.3 FT

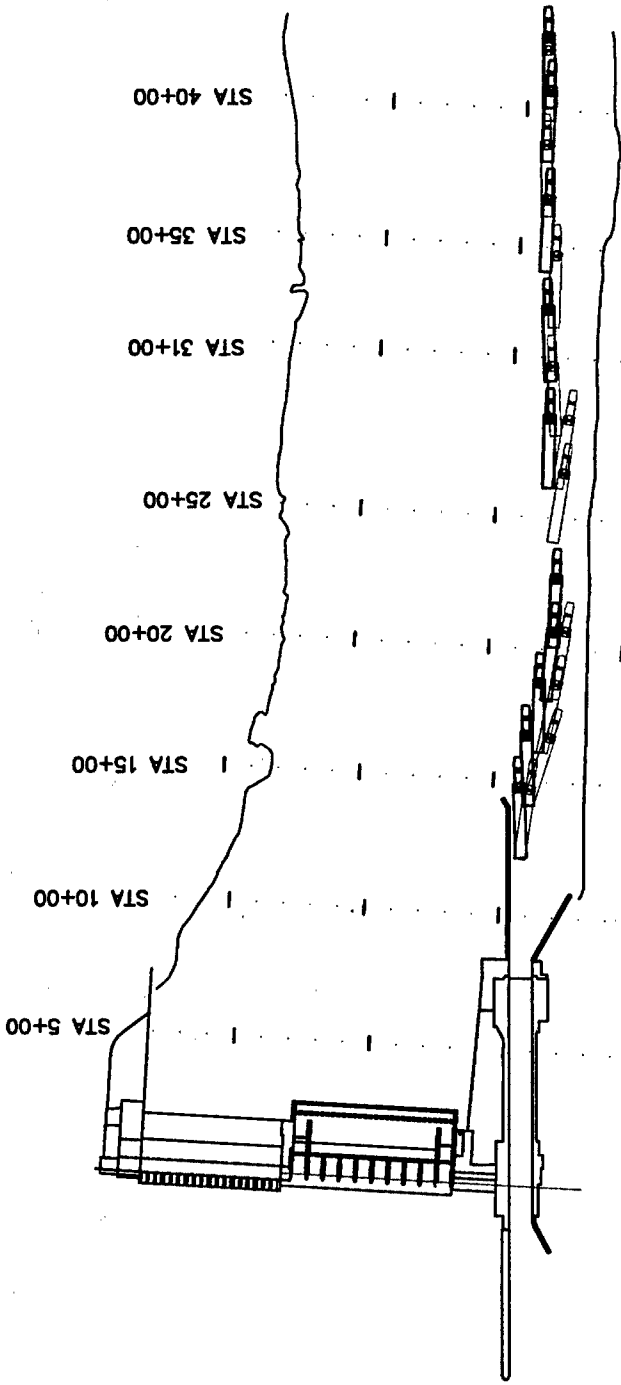

TOW PATHS  
 UPBOUND  
 10 DEFLECTORS  
 1-BARGE FLOTILLA  
 (1 wide x 1 long)  
 DISCHARGE: 172,300 CFS  
 TAILWATER EL: 351.0 FT

POWERHOUSE OPERATION, Q/UNITS, KCFS

UNIT	1	2	3	4	5	6
Q	12.3	12.3	12.3	17.7	0	17.7

SPILLWAY OPERATION, STOPS (FT)

BAY	1	2	3	4	5	6	7	8	9	10
STOPS	2	7	7	7	7	7	7	7	7	6

OPERATING CONDITIONS

POWERHOUSE DISCHARGE = 72.3 KCFS  
 SPILLWAY DISCHARGE = 100 KCFS  
 HEADPOOL ELEVATION = 439.0  
 TAILWATER ELEVATION = 351.0

LEGEND

1-BARGE TOW: 1 WIDE X 1 LONG  
 42 ft WIDE X 274 ft LONG X 13 ft DRAFT  
 WITH 100-ft PUSHER BOAT

SCALES IN FEET



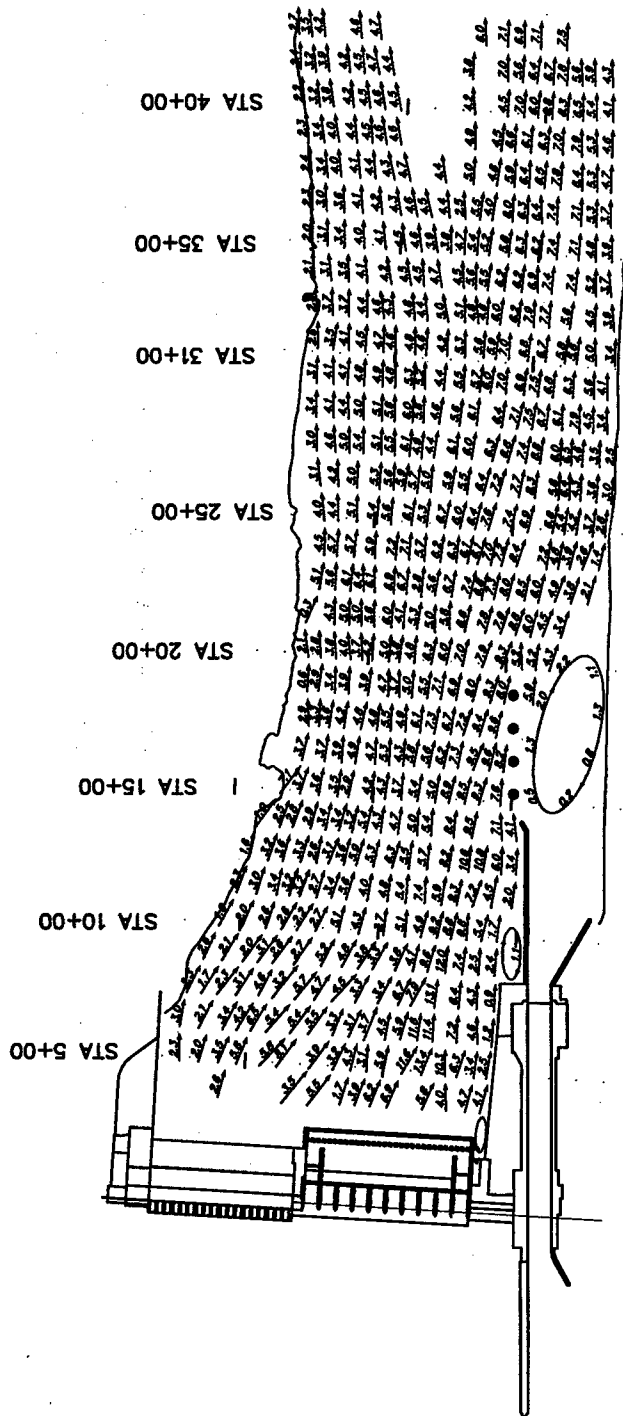

**VELOCITIES AND  
CURRENT DIRECTIONS**  
10 DEFLECTORS / 4 CELLS  
DISCHARGE: 102,300 CFS  
TAILWATER: 346.5 FT

**POWERHOUSE OPERATION, Q/UNITS, KCFS**

UNIT	1	2	3	4	5	6
Q	12.3	12.3	12.3	17.7	0	17.7

**SPILLWAY OPERATION, STOPS (FT)**

BAY	1	2	3	4	5	6	7	8	9	10
STOPS	1	2	2	2	2	2	1	2	2	1

**OPERATING CONDITIONS**  
POWERHOUSE DISCHARGE = 72.3 KCFS  
SPILLWAY DISCHARGE = 30 KCFS  
HEADPOOL ELEVATION = 439.0  
TAILWATER ELEVATION = 346.5

**SCALES IN FEET**



**LEGEND**

VELOCITY IN FEET PER SECOND (13.0 ft DRAFT)  
VELOCITY IN FEET PER SECOND (7.0 ft DRAFT)

**NOTE :** VELOCITIES AND CURRENT DIRECTION  
OBTAINED WITH FLOATS SUBMERGED TO  
DRAFT OF 13.0 ft and 7.0 ft

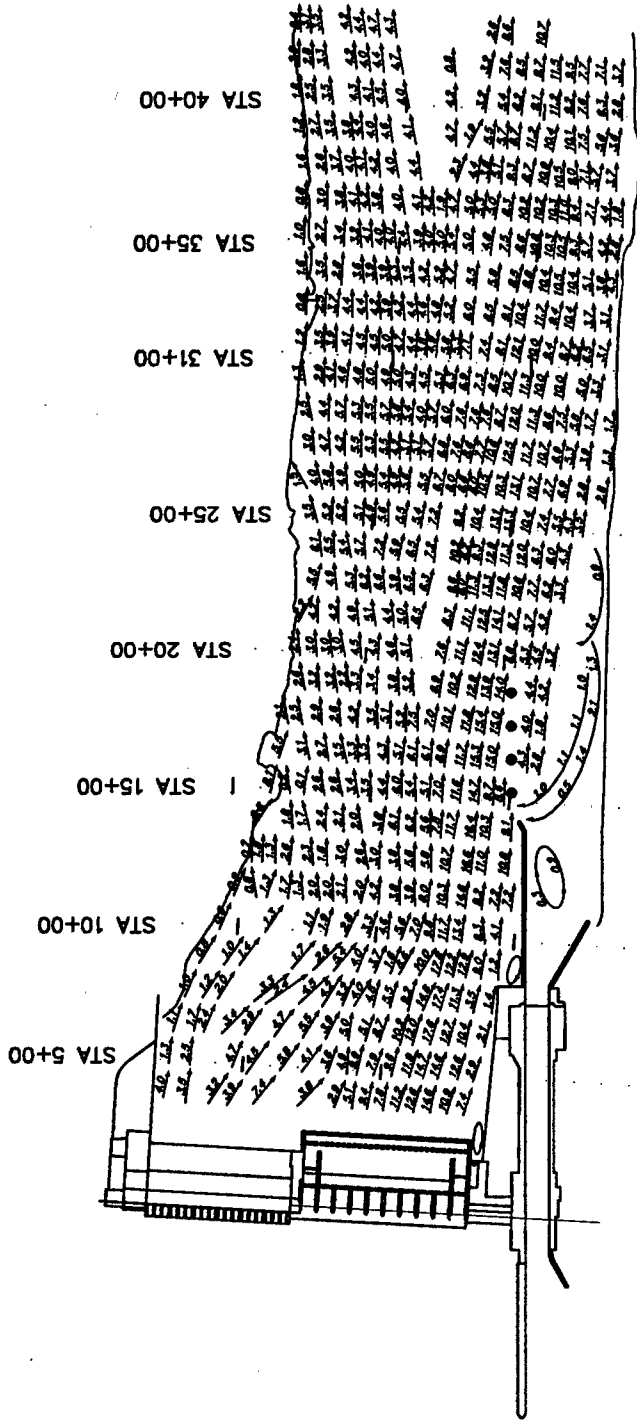

**VELOCITIES AND  
CURRENT DIRECTIONS**  
10 DEFLECTORS / 4 CELLS  
DISCHARGE: 127,300 CFS  
TAILWATER: 348.3 FT

**POWERHOUSE OPERATION, Q/UNITS, KCFS**

UNIT	1	2	3	4	5	6
Q	12.3	12.3	12.3	17.7	0	17.7

**SPILLWAY OPERATION, STOPS (FT)**

BAY	1	2	3	4	5	6	7	8	9	10
STOPS	2	3	3	4	4	4	4	4	4	3

**SCALES IN FEET**



**OPERATING CONDITIONS**

POWERHOUSE DISCHARGE = 72.3 KCFS  
 SPILLWAY DISCHARGE = 55 KCFS  
 HEADPOOL ELEVATION = 439.0  
 TAILWATER ELEVATION = 348.3

**LEGEND**

VELOCITY IN FEET PER SECOND (13.0 ft DRAFT)  
 VELOCITY IN FEET PER SECOND (7.0 ft DRAFT)

NOTE: VELOCITIES AND CURRENT DIRECTION  
 OBTAINED WITH FLOATS SUBMERGED TO  
 DRAFT OF 13.0 ft and 7.0 ft

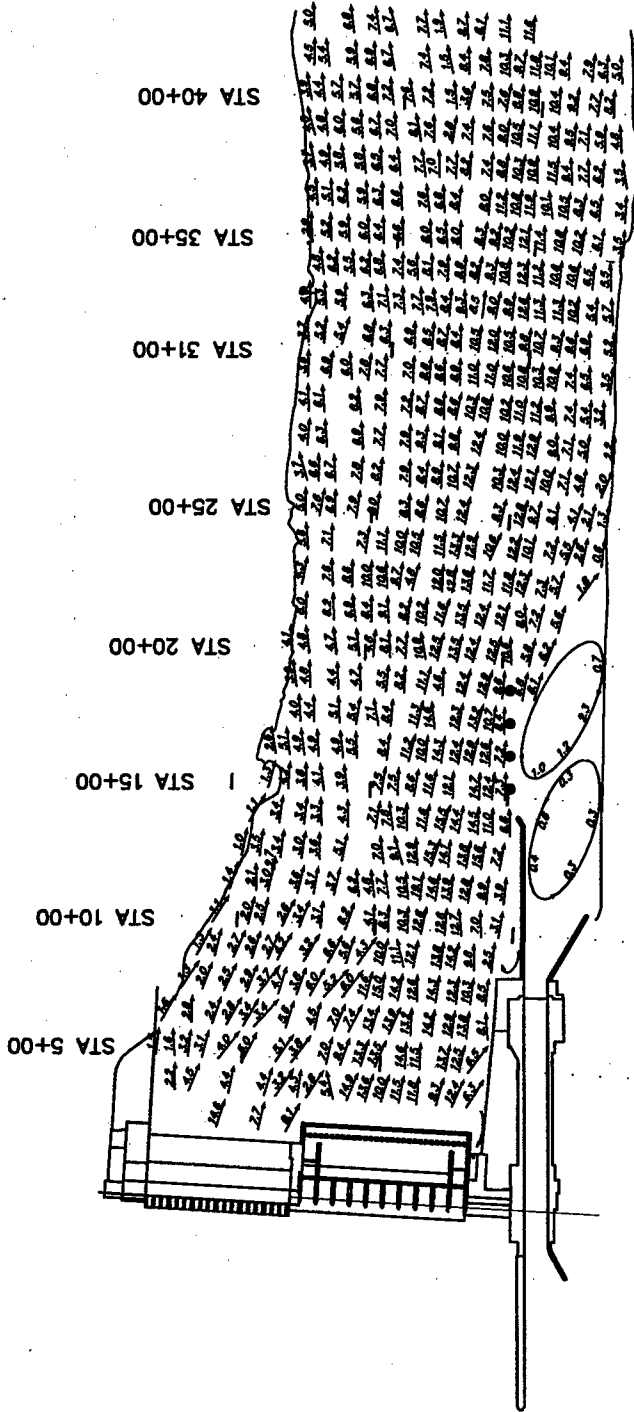

**OPERATING CONDITIONS**

POWERHOUSE DISCHARGE = 72.3 KCFS  
 SPILLWAY DISCHARGE = 100 KCFS  
 HEADPOOL ELEVATION = 439.0  
 TAILWATER ELEVATION = 351.0

**LEGEND**

VELOCITY IN FEET PER SECOND (13.0 ft DRAFT)  
 VELOCITY IN FEET PER SECOND (7.0 ft DRAFT)

NOTE : VELOCITIES AND CURRENT DIRECTION  
 OBTAINED WITH FLOATS SUBMERGED TO  
 DRAFT OF 13.0 ft and 7.0 ft

**POWERHOUSE OPERATION, Q/UNITS, KCFS**

UNIT	1	2	3	4	5	6
Q	12.3	12.3	12.3	17.7	0	17.7

**SPILLWAY OPERATION, STOPS (FT)**

BAY	1	2	3	4	5	6	7	8	9	10
STOPS	2	7	7	7	7	7	7	7	7	6

**SCALES IN FEET**



**VELOCITIES AND  
 CURRENT DIRECTIONS  
 10 DEFLECTORS / 4 CELLS  
 DISCHARGE: 172,300 CFS  
 TAILWATER: 351.0 FT**

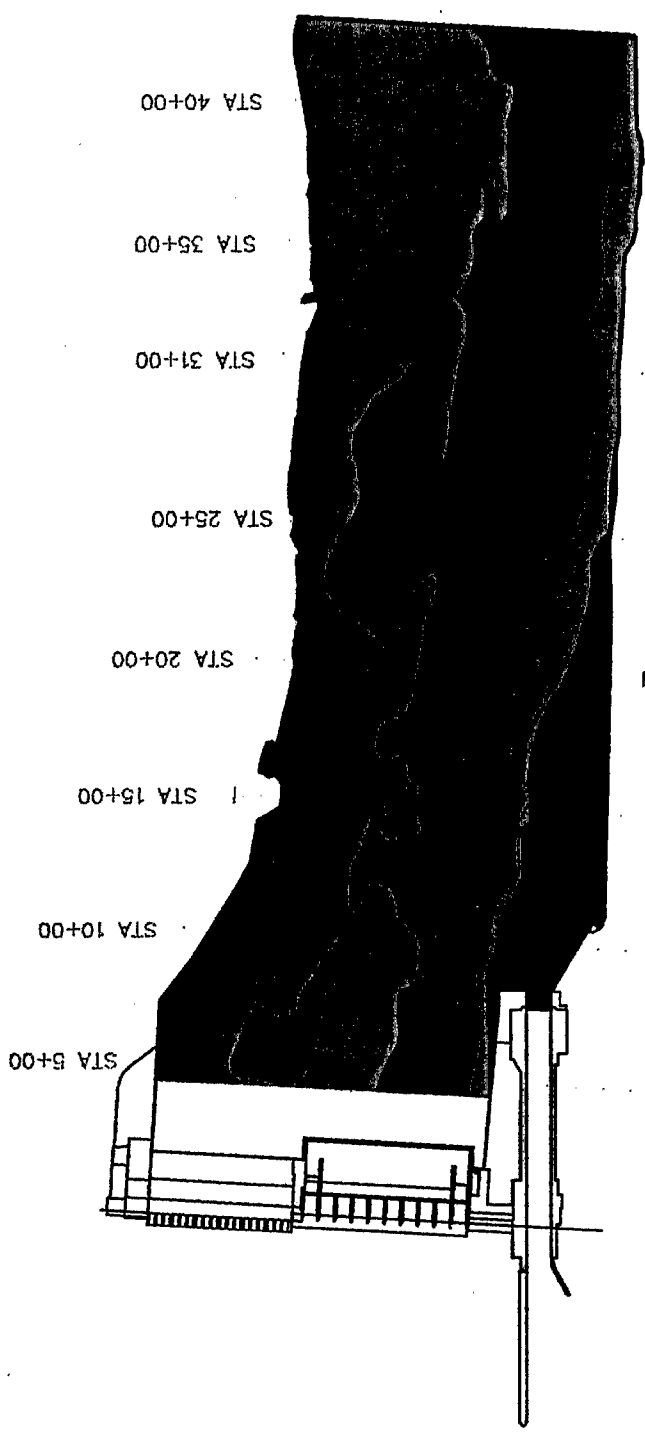

STA 5+00

STA 10+00

STA 15+00

STA 20+00

STA 25+00

STA 31+00

STA 35+00

STA 40+00

**OPERATING CONDITIONS**

POWERHOUSE DISCHARGE = 72.3 KCFS  
 SPILLWAY DISCHARGE = 30 KCFS  
 HEADPOOL ELEVATION = 439.0  
 TAILWATER ELEVATION = 346.5

**LEGEND**

- 0.0 - 2.5 fps
- 2.6 - 5.0 fps
- 5.1 - 7.5 fps
- 7.6 - 10.0 fps
- 10.1 - 12.5 fps
- 12.6 - 15.0 fps
- > 15.1 fps

**POWERHOUSE OPERATION, Q/UNITS, KCFS**

UNIT	1	2	3	4	5	6
Q	12.3	12.3	12.3	17.7	0	17.7

**SPILLWAY OPERATION, STOPS (FT)**

BAY	1	2	3	4	5	6	7	8	9	10
STOPS	1	2	2	2	2	2	1	2	2	2

**SCALES IN FEET**



**ISOVEL PLOT**  
 10 DEFLECTORS / 4 CELLS  
 DISCHARGE: 102,300 CFS  
 TAILWATER: 346.5 FT

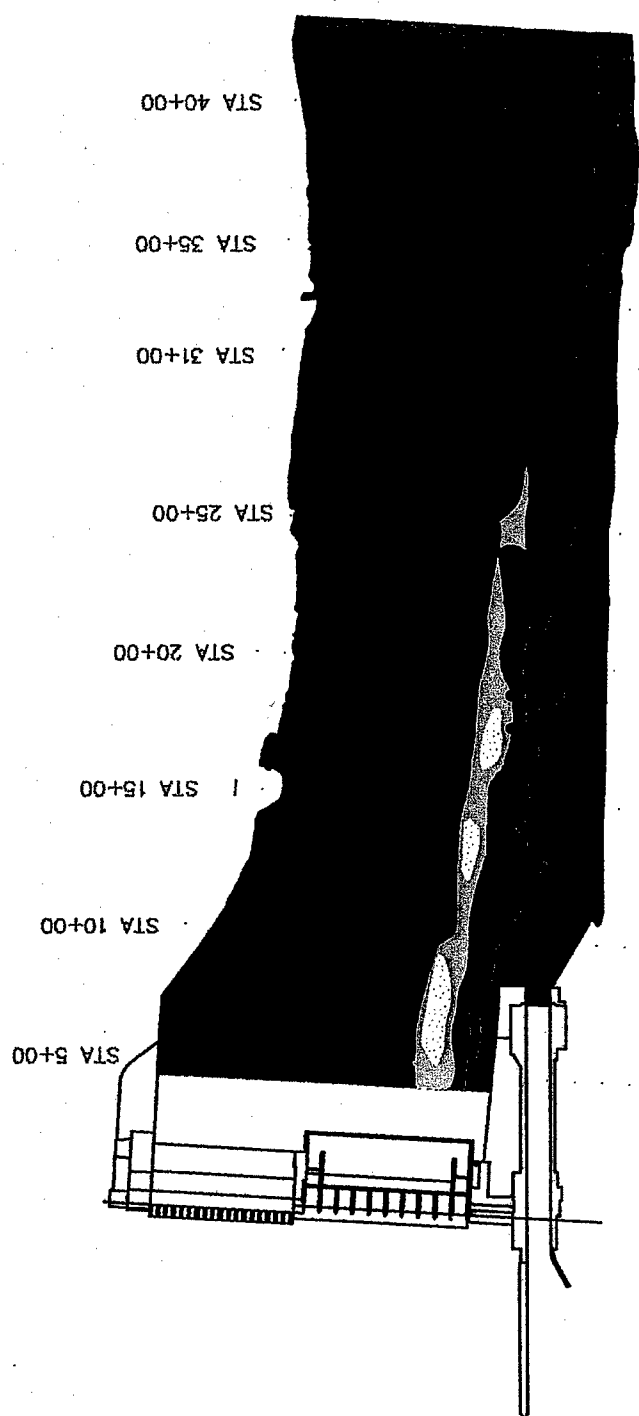

STA 5+00  
 STA 10+00  
 STA 15+00  
 STA 20+00  
 STA 25+00  
 STA 31+00  
 STA 35+00  
 STA 40+00

**OPERATING CONDITIONS**

POWERHOUSE DISCHARGE = 72.3 KCFS  
 SPILLWAY DISCHARGE = 30 KCFS  
 HEADPOOL ELEVATION = 439.0  
 TAILWATER ELEVATION = 346.5

**POWERHOUSE OPERATION, Q/UNITS, KCFS**

UNIT	1	2	3	4	5	6
Q	12.3	12.3	12.3	17.7	0	17.7

**SPILLWAY OPERATION, STOPS (FT)**

BAY	1	2	3	4	5	6	7	8	9	10
STOPS	1	2	2	2	2	1	2	1	2	1.5

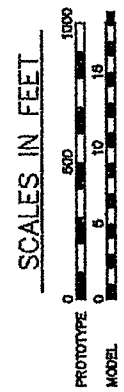
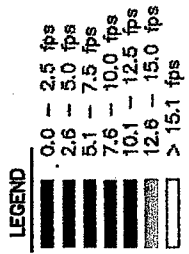

**ISOVEL PLOT**  
 10 DEFLECTORS / 4 CELLS  
 DISCHARGE: 127,300 CFS  
 TAILWATER: 346.5 FT

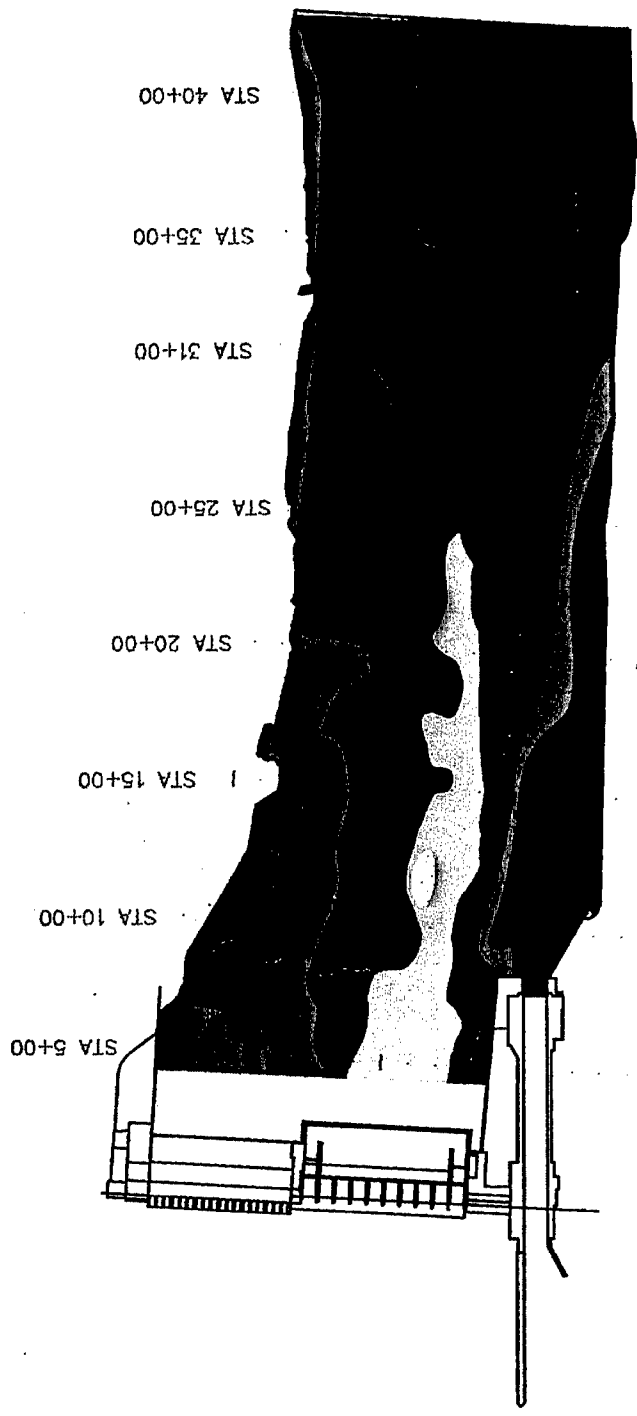

### ISOVEL PLOT

10 DEFLECTORS / 4 CELLS  
 DISCHARGE: 172,300 CFS  
 TAILWATER: 348.3 FT

POWERHOUSE OPERATION, Q/UNITS, KCFS

UNIT	1	2	3	4	5	6
Q	12.3	12.3	12.3	17.7	0	17.7

SPILLWAY OPERATION, STOPS (FT)

BAY	1	2	3	4	5	6	7	8	9	10
STOPS	2	3	3	4	4	4	4	4	4	3

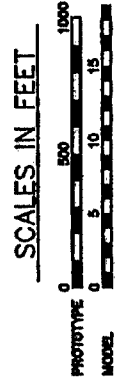

**OPERATING CONDITIONS**  
 POWERHOUSE DISCHARGE = 72.3 KCFS  
 SPILLWAY DISCHARGE = 55 KCFS  
 HEADPOOL ELEVATION = 439.0  
 TAILWATER ELEVATION = 348.3

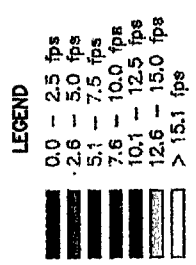

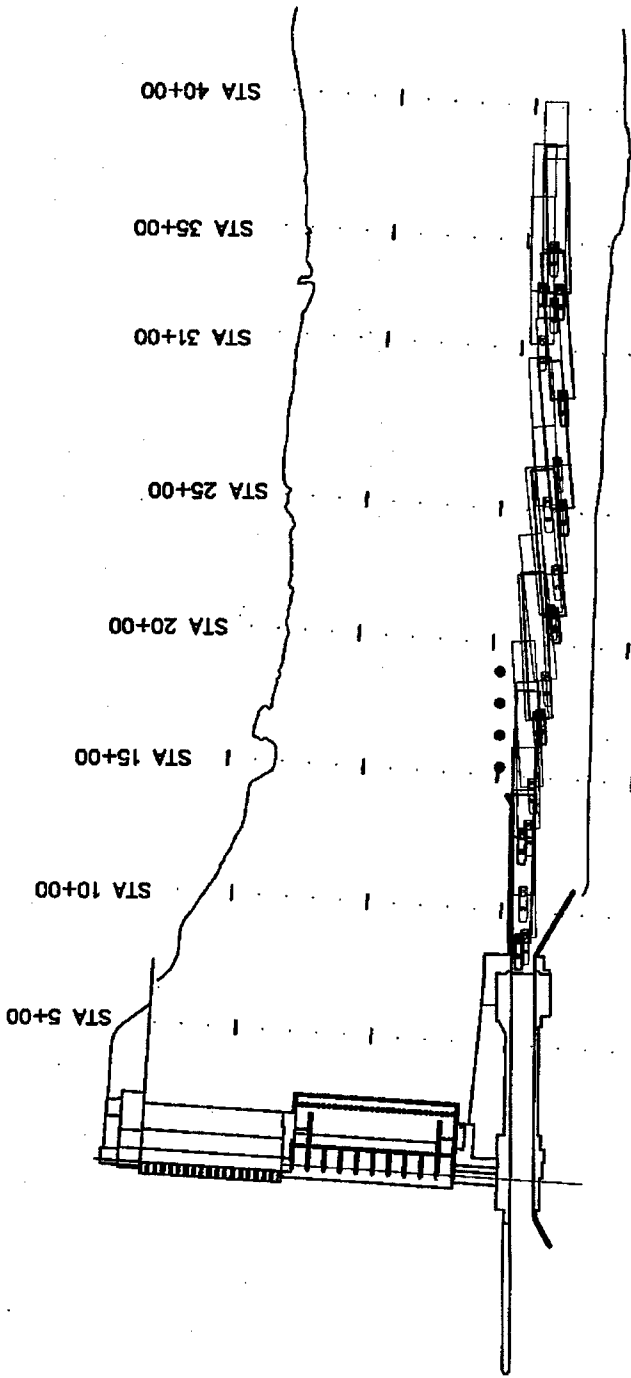

**OPERATING CONDITIONS**

POWERHOUSE DISCHARGE = 72.3 KCFS  
 SPILLWAY DISCHARGE = 30 KCFS  
 HEADPOOL ELEVATION = 439.0  
 TAILWATER ELEVATION = 346.5

**POWERHOUSE OPERATION, Q/UNITS, KCFS**

UNIT	1	2	3	4	5	6
Q	12.3	12.3	12.3	17.7	0	17.7

**SPILLWAY OPERATION, STOPS (FT)**

BAY	1	2	3	4	5	6	7	8	9	10
STOPS	1	2	2	2	2	1	2	2	1	2

**LEGEND**

4-BARGE TOW: 2 WIDE X 2 LONG  
 84 ft WIDE X 548 ft LONG X 13 ft DRAFT  
 WITH 100-ft PUSHER BOAT

**TOW PATHS  
 DOWNBOUND**  
 10 DEFLECTORS/4 CELLS  
 4-BARGE FLOTILLA  
 (2 wide x 2 long)  
 DISCHARGE: 102,300 CFS  
 TAILWATER EL: 346.5 FT

**SCALES IN FEET**



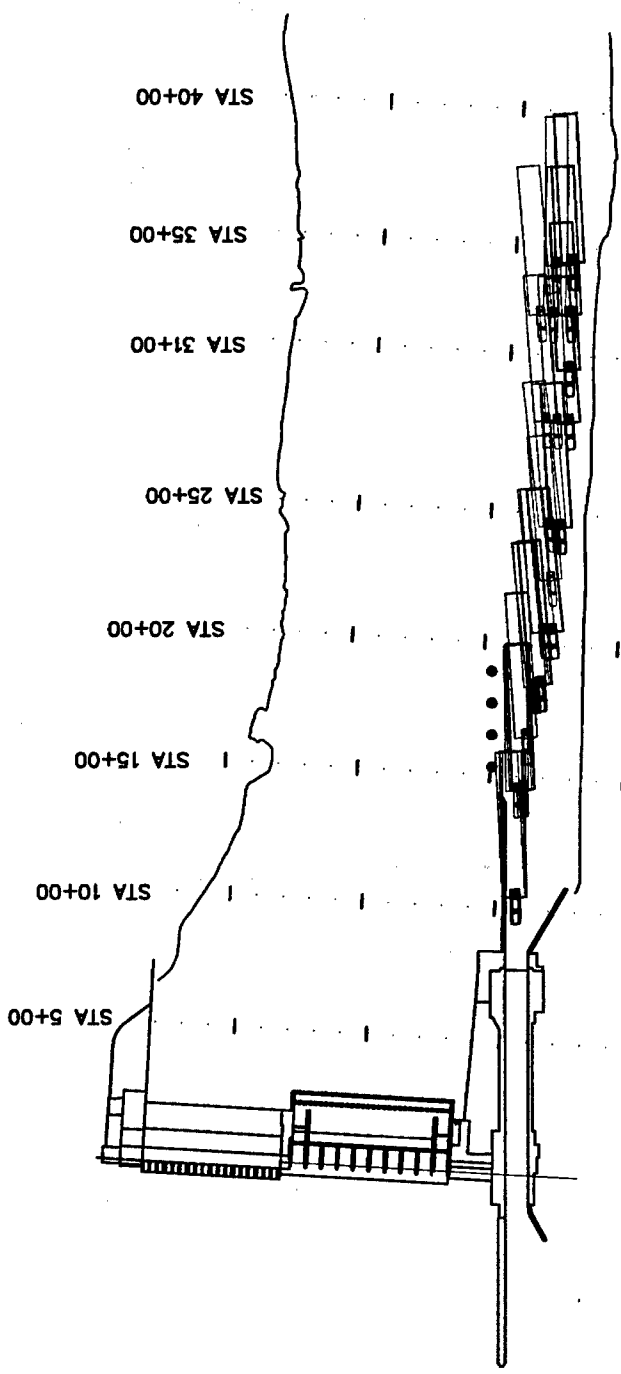

**OPERATING CONDITIONS**  
 POWERHOUSE DISCHARGE = 72.3 KCFS  
 SPILLWAY DISCHARGE = 55 KCFS  
 HEADPOOL ELEVATION = 439.0  
 TAILWATER ELEVATION = 348.3

**POWERHOUSE OPERATION, Q/UNITS, KCFS**

UNIT	1	2	3	4	5	6
Q	12.3	12.3	12.3	17.7	0	17.7

**SPILLWAY OPERATION, STOPS (FT)**

BAY	1	2	3	4	5	6	7	8	9	10
STOPS	2	3	3	4	4	4	4	4	4	3

**LEGEND**

4-BARGE TOW: 2 WIDE X 2 LONG  
 84 ft WIDE X 548 ft LONG X 13 ft DRAFT  
 WITH 100-ft PUSHER BOAT

**SCALES IN FEET**



**TOW PATHS  
 DOWNBOUND**  
 10 DEFLECTORS/ 4 CELLS  
 4-BARGE FLOTILLA  
 (2 wide x 2 long)  
 DISCHARGE: 127,300 CFS  
 TAILWATER EL: 348.3 FT

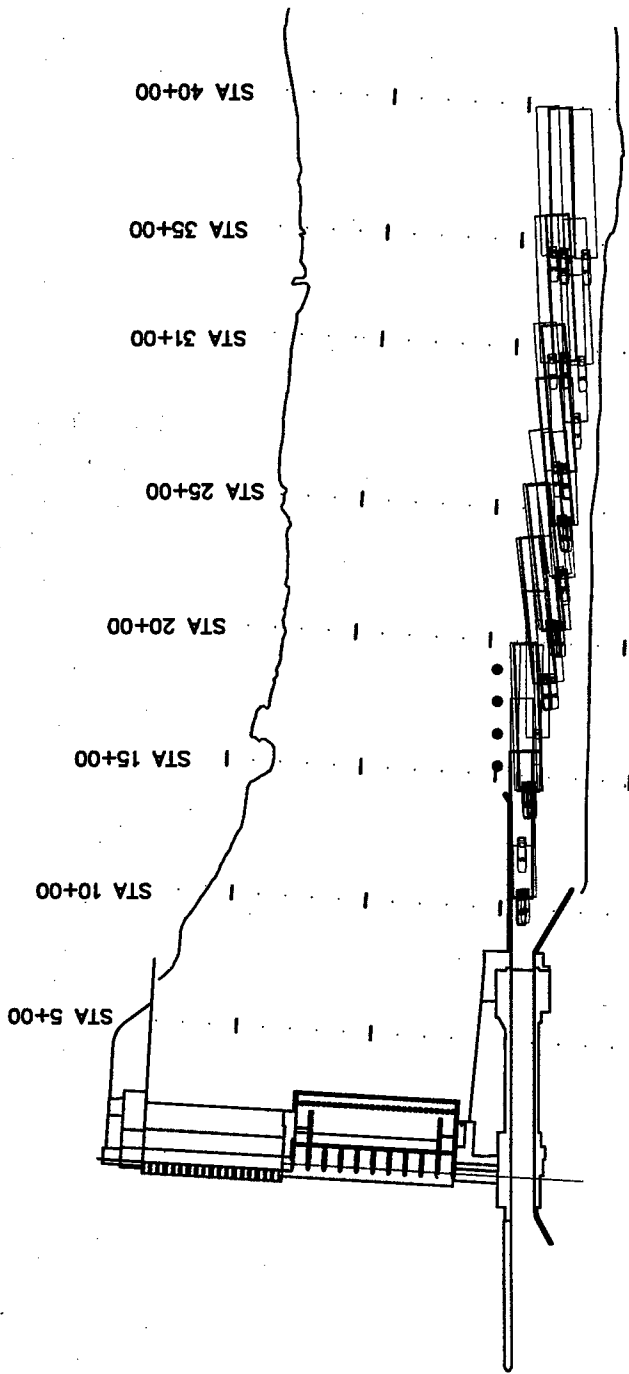

**OPERATING CONDITIONS**

POWERHOUSE DISCHARGE = 72.3 KCFS  
 SPILLWAY DISCHARGE = 100 KCFS  
 HEADPOOL ELEVATION = 439.0  
 TAILWATER ELEVATION = 351.0

**POWERHOUSE OPERATION, Q/UNITS, KCFS**

UNIT	1	2	3	4	5	6
Q	12.3	12.3	12.3	17.7	0	17.7

**SPILLWAY OPERATION, STOPS (FT)**

BAY	1	2	3	4	5	6	7	8	9	10
STOPS	2	7	7	7	7	7	7	7	7	6

**LEGEND**

4-BARGE TOW: 2 WIDE X 2 LONG  
 84 ft WIDE X 548 ft LONG X 13 ft DRAFT  
 WITH 100-ft PUSHER BOAT

TOW PATHS  
 DOWNBOUND  
 10 DEFLECTORS/ 4 CELLS  
 4-BARGE FLOTILLA  
 (2 wide x 2 long)  
 DISCHARGE: 172,300 CFS  
 TAILWATER EL: 351.0 FT

**SCALES IN FEET**



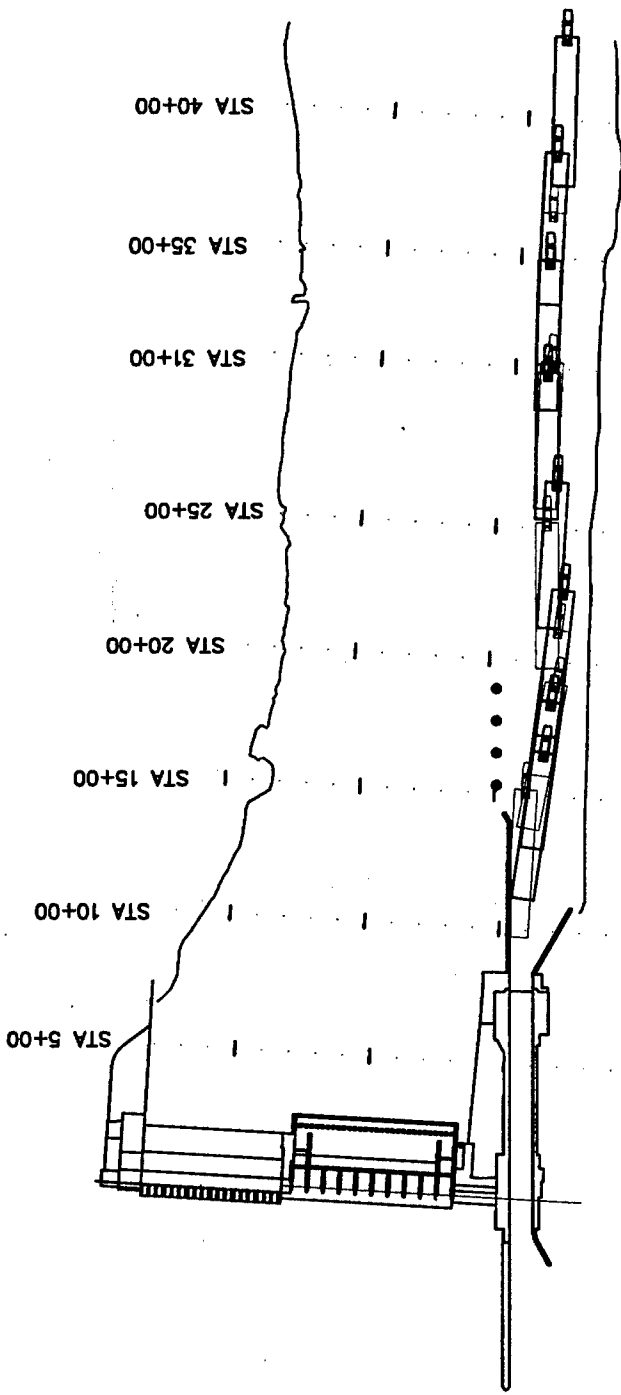

POWERHOUSE OPERATION, Q/UNITS, KCFS

UNIT	1	2	3	4	5	6
Q	12.3	12.3	12.3	17.7	0	17.7

SPILLWAY OPERATION, STOPS (FT)

BAY	1	2	3	4	5	6	7	8	9	10
STOPS	1	2	2	2	2	1	2	2	1	2

**OPERATING CONDITIONS**  
 POWERHOUSE DISCHARGE = 72.3 KCFS  
 SPILLWAY DISCHARGE = 30 KCFS  
 HEADPOOL ELEVATION = 439.0  
 TAILWATER ELEVATION = 346.5

**TOW PATHS**  
 UPBOUND  
 10 DEFLECTORS/ 4 CELLS  
 4-BARGE FLOTILLA  
 (2 wide x 2 long)  
 DISCHARGE: 102,300 CFS  
 TAILWATER EL: 346.5 FT

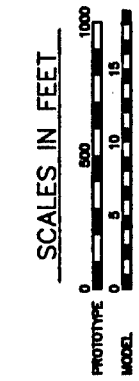

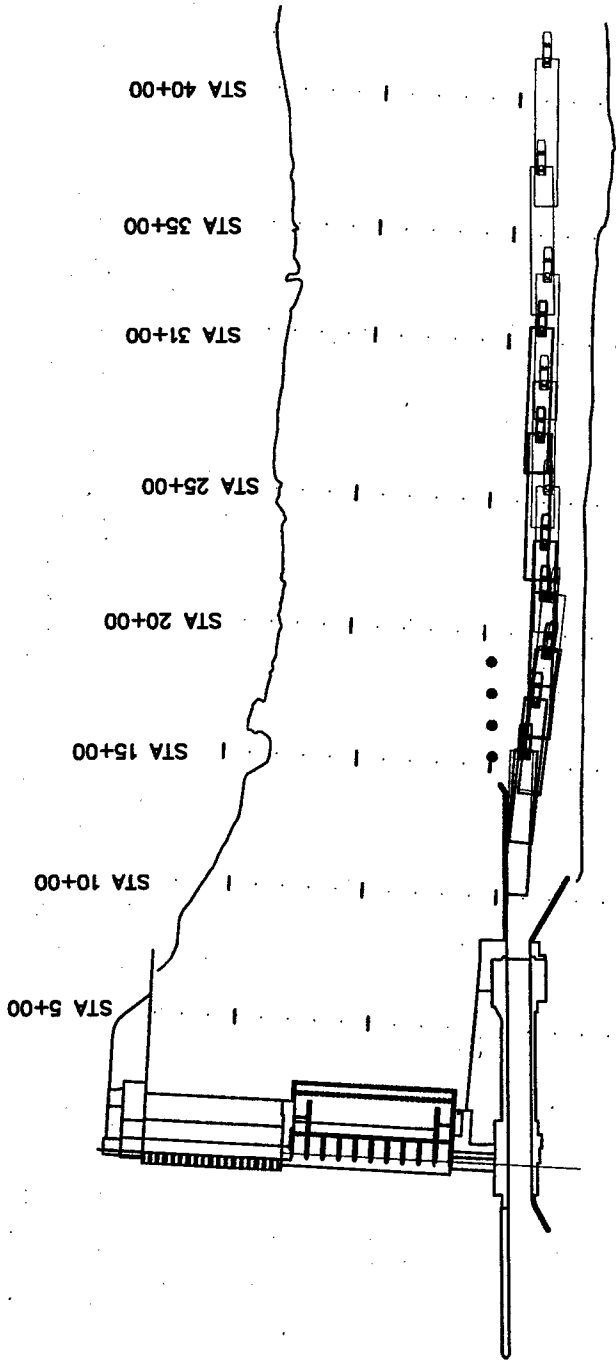

**OPERATING CONDITIONS**  
 POWERHOUSE DISCHARGE = 72.3 KCFS  
 SPILLWAY DISCHARGE = 55 KCFS  
 HEADPOOL ELEVATION = 439.0  
 TAILWATER ELEVATION = 348.3

**POWERHOUSE OPERATION, Q/UNITS, KCFS**

UNIT	1	2	3	4	5	6
Q	12.3	12.3	12.3	17.7	0	17.7

**SPILLWAY OPERATION, STOPS (FT)**

BAY	1	2	3	4	5	6	7	8	9	10
STOPS	2	3	3	4	4	4	4	4	4	3

**LEGEND**

4-BARGE TOW: 2 WIDE X 2 LONG  
 84 ft WIDE X 548 ft LONG X 13 ft DRAFT  
 WITH 100-ft PUSHER BOAT

**SCALES IN FEET**



**TOW PATHS  
 UPBOUND**  
 10 DEFLECTORS/ 4 CELLS  
 4-BARGE FLOTILLA  
 (2 wide x 2 long)  
 DISCHARGE: 127,300 CFS  
 TAILWATER EL: 348.3 FT

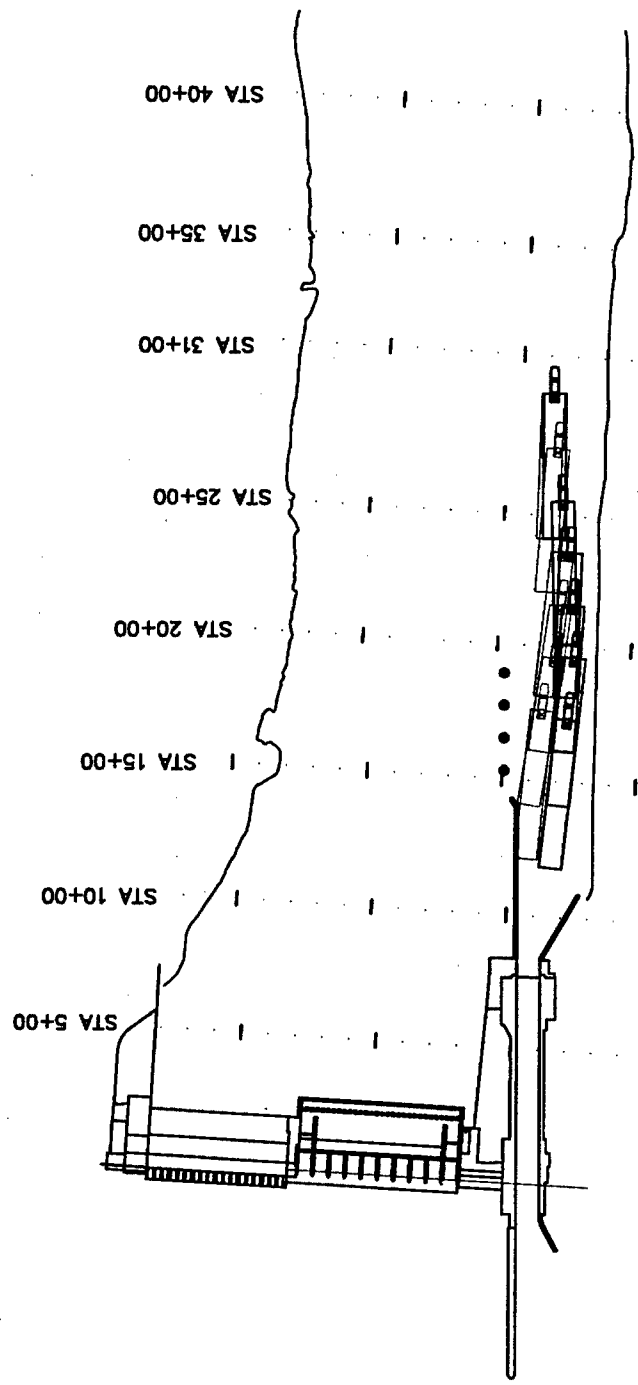

**OPERATING CONDITIONS**  
 POWERHOUSE DISCHARGE = 72.3 KCFS  
 SPILLWAY DISCHARGE = 100 KCFS  
 HEADPOOL ELEVATION = 438.0  
 TAILWATER ELEVATION = 351.0

**POWERHOUSE OPERATION, Q/UNITS, KCFS**

UNIT	1	2	3	4	5	6
Q	12.3	12.3	12.3	17.7	0	17.7

**SPILLWAY OPERATION, STOPS (FT)**

BAY	1	2	3	4	5	6	7	8	9	10
STOPS	2	7	7	7	7	7	7	7	7	2

**LEGEND**

4-BARGE TOW: 2 WIDE X 2 LONG  
 84 ft WIDE X 548 ft LONG X 13 ft DRAFT  
 WITH 100-ft PUSHER BOAT

**SCALES IN FEET**



**TOW PATHS  
 UPBOUND**  
 10 DEFLECTORS/ 4 CELLS  
 4-BARGE FLOTILLA  
 (2 wide x 2 long)  
 DISCHARGE: 172,300 CFS  
 TAILWATER EL: 351.0 FT

# REPORT DOCUMENTATION PAGE

Form Approved  
OMB No. 0704-0188

Public reporting burden for this collection of information is estimated to average 1 hour per response, including the time for reviewing instructions, searching existing data sources, gathering and maintaining the data needed, and completing and reviewing this collection of information. Send comments regarding this burden estimate or any other aspect of this collection of information, including suggestions for reducing this burden to Department of Defense, Washington Headquarters Services, Directorate for Information Operations and Reports (0704-0188), 1215 Jefferson Davis Highway, Suite 1204, Arlington, VA 22202-4302. Respondents should be aware that notwithstanding any other provision of law, no person shall be subject to any penalty for failing to comply with a collection of information if it does not display a currently valid OMB control number. **PLEASE DO NOT RETURN YOUR FORM TO THE ABOVE ADDRESS.**

<b>1. REPORT DATE (DD-MM-YYYY)</b> August 2002		<b>2. REPORT TYPE</b> Final report		<b>3. DATES COVERED (From - To)</b>	
<b>4. TITLE AND SUBTITLE</b>  Navigation Conditions in Lower Lock Approach of Ice Harbor Lock and Dam, Snake River, Washington				<b>5a. CONTRACT NUMBER</b>	
				<b>5b. GRANT NUMBER</b>	
				<b>5c. PROGRAM ELEMENT NUMBER</b>	
				<b>5d. PROJECT NUMBER</b>	
<b>6. AUTHOR(S)</b>  Howard Park, Dwayne Fuller				<b>5e. TASK NUMBER</b>	
				<b>5f. WORK UNIT NUMBER</b>	
				<b>8. PERFORMING ORGANIZATION REPORT NUMBER</b>  ERDC/CHL TR-02-13	
<b>7. PERFORMING ORGANIZATION NAME(S) AND ADDRESS(ES)</b>  U.S. Army Engineer Research and Development Center Coastal and Hydraulics Laboratory 3909 Halls Ferry Road Vicksburg, MS 39180-6199				<b>10. SPONSOR/MONITOR'S ACRONYM(S)</b>	
<b>9. SPONSORING / MONITORING AGENCY NAME(S) AND ADDRESS(ES)</b>  U.S. Army Engineer District, Walla, Walla 201 North 3 <sup>rd</sup> Avenue Walla Walla, WA 99362				<b>11. SPONSOR/MONITOR'S REPORT NUMBER(S)</b>	
				<b>12. DISTRIBUTION / AVAILABILITY STATEMENT</b> Approved for public release; distribution is unlimited.	
<b>13. SUPPLEMENTARY NOTES</b>					
<b>14. ABSTRACT</b>  Possible construction of facilities to improve passage of juvenile and adult migratory fish at Ice Harbor Lock and Dam on the Snake River, Washington, caused concern over the impacts to navigation especially in the lower lock approach. A 1:55-scale physical model of the project was used to help identify these impacts. Navigation conditions in the lower lock approach were determined for various discharges and barge configurations of rock dikes placed in the lower lock approach. The study revealed that the installation flow deflectors at Ice Harbor Dam caused adverse impacts to navigation in the lower lock approach. An intense eddy formed near the downstream guard wall, and the angle magnitude of the crosscurrent in the lower lock approach were larger than those with the no-deflector conditions. Several alternatives included the placement of four, 40-ft-diam circular cells, 120-ft on center, located downstream, parallel, and riverward of the lower guard wall.					
<b>15. SUBJECT TERMS</b> Coffer cells                      Ice Harbor Lock and Dam Fish passage                      Navigation conditions Flow deflectors                      Snake River					
<b>16. SECURITY CLASSIFICATION OF:</b>			<b>17. LIMITATION OF ABSTRACT</b>	<b>18. NUMBER OF PAGES</b>  112	<b>19a. NAME OF RESPONSIBLE PERSON</b>
<b>a. REPORT</b> UNCLASSIFIED	<b>b. ABSTRACT</b> UNCLASSIFIED	<b>c. THIS PAGE</b> UNCLASSIFIED			<b>19b. TELEPHONE NUMBER (include area code)</b>