

**AFWAL-TM-85-256**

**A-7D HAVE BOUNCE  
Volume 1: Test Description**

**David Banaszak  
John Riechers  
Dansen Brown  
Earl Rogers**

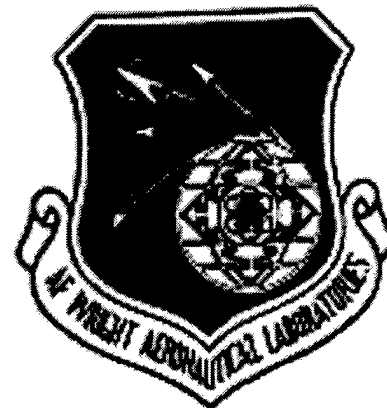

**Analytical Structural Mechanics Branch (AFRL/VASM)  
Structures Division  
Air Vehicles Directorate  
Air Force Research Laboratory, Air Force Materiel Command  
Wright-Patterson Air Force Base, OH 45433-7542**

**DECEMBER 1985**

**Final Report for 01 October 1984 – 01 March 1985**

**Approved for public release; distribution is unlimited.**

**20030304 038**

**AIR VEHICLES DIRECTORATE  
AIR FORCE RESEARCH LABORATORY  
AIR FORCE MATERIEL COMMAND  
WRIGHT-PATTERSON AIR FORCE BASE, OH 45433-7542**

## NOTICE

Using government drawings, specifications, or other data included in this document for any purpose other than government procurement does not in any way obligate the U.S. Government. The fact that the government formulated or supplied the drawings, specifications, or other data does not license the holder or any other person or corporation; or convey and rights or permission to manufacture, use, or sell any patented invention that may relate to them.

This report has been reviewed by the Office of Public Affairs (ASC/PA) and is releasable to the National Technical Information Service (NTIS). At NTIS, it will be available to the general public, including foreign nations.

This technical report has been reviewed and is approved for publication.



DAVID BANASZAK  
Project Engineer  
Analytical Structural Mechanics Branch  
Structures Division



GERALD PLZAK  
Technical Manager  
Analytical Structural Mechanics Branch  
Structures Division



JEROME PEARSON  
Chief  
Analytical Structural Mechanics Branch  
Structures Division

Copies of this report should not be returned unless return is required by security considerations, contractual obligations, or notice on a specific document.

# REPORT DOCUMENTATION PAGE

*Form Approved*  
OMB No. 0704-0188

The public reporting burden for this collection of information is estimated to average 1 hour per response, including the time for reviewing instructions, searching existing data sources, searching existing data sources, gathering and maintaining the data needed, and completing and reviewing the collection of information. Send comments regarding this burden estimate or any other aspect of this collection of information, including suggestions for reducing this burden, to Department of Defense, Washington Headquarters Services, Directorate for Information Operations and Reports (0704-0188), 1215 Jefferson Davis Highway, Suite 1204, Arlington, VA 22202-4302. Respondents should be aware that notwithstanding any other provision of law, no person shall be subject to any penalty for failing to comply with a collection of information if it does not display a currently valid OMB control number. PLEASE DO NOT RETURN YOUR FORM TO THE ABOVE ADDRESS.

<b>1. REPORT DATE (DD-MM-YY)</b> December 1985		<b>2. REPORT TYPE</b> Final		<b>3. DATES COVERED (From - To)</b> 10/01/1984 - 03/01/1985	
<b>4. TITLE AND SUBTITLE</b> A-7D HAVE BOUNCE Volume 1: Test Description				<b>5a. CONTRACT NUMBER</b> In-house	
				<b>5b. GRANT NUMBER</b>	
				<b>5c. PROGRAM ELEMENT NUMBER</b> 64708F	
<b>6. AUTHOR(S)</b> David Banaszak John Riechers Dansen Brown Earl Rogers				<b>5d. PROJECT NUMBER</b> 2054	
				<b>5e. TASK NUMBER</b> 50	
				<b>5f. WORK UNIT NUMBER</b> 01	
<b>7. PERFORMING ORGANIZATION NAME(S) AND ADDRESS(ES)</b> Analytical Structural Mechanics Branch (AFRL/VASM) Structures Division Air Vehicles Directorate Air Force Research Laboratory, Air Force Materiel Command Wright-Patterson Air Force Base, OH 45433-7542				<b>8. PERFORMING ORGANIZATION REPORT NUMBER</b>  AFWAL-TM-85-256-FIBG	
<b>9. SPONSORING/MONITORING AGENCY NAME(S) AND ADDRESS(ES)</b> Air Vehicles Directorate Air Force Research Laboratory Air Force Materiel Command Wright-Patterson Air Force Base, OH 45433-7542				<b>10. SPONSORING/MONITORING AGENCY ACRONYM(S)</b> AFRL/VASM	
				<b>11. SPONSORING/MONITORING AGENCY REPORT NUMBER(S)</b> AFWAL-TM-85-256	
<b>12. DISTRIBUTION/AVAILABILITY STATEMENT</b> Approved for public release; distribution is unlimited.					
<b>13. SUPPLEMENTARY NOTES</b> This version of the report is the best quality available. See also AFWAL-TM-85-257, "Volume 2: Test Data."					
<b>14. ABSTRACT</b> AFWAL/FIB has been involved in the modeling, instrumentation, and testing of Air Force aircraft response to rough runways since the mid-1970s at the inception of the HAVE BOUNCE program. This report covers the instrumentation and testing of the A-7D attack aircraft operations over rough runways. Typical data were included to provide an understanding of the results. A complete data set is published as AFWAL-TM-85-257. Testing was performed at Whiteman Air Force Base, MO between December 5 and December 20, 1984. The aircraft was provided and supported by the 132 <sup>nd</sup> Tactical Fighter Wing, Iowa Air National Guard.  Two aircraft configurations were tested during this project, a typical lightweight landing and maximum weight takeoff. These aircraft were tested over single and multiple bumps of 3-inch height and 78-foot length. This aircraft appears to be extremely capable of handling runway roughness. The limiting factor for the system is nose gear tire bottoming. This can be alleviated by increasing the nose gear tire pressure.					
<b>15. SUBJECT TERMS</b>					
<b>16. SECURITY CLASSIFICATION OF:</b>			<b>17. LIMITATION OF ABSTRACT:</b> SAR	<b>18. NUMBER OF PAGES</b> 110	<b>19a. NAME OF RESPONSIBLE PERSON (Monitor)</b> David Banaszak <b>19b. TELEPHONE NUMBER (Include Area Code)</b> (937) 904-6859
<b>a. REPORT</b> Unclassified	<b>b. ABSTRACT</b> Unclassified	<b>c. THIS PAGE</b> Unclassified			

## NOTICE

Using government drawings, specifications, or other data included in this document for any purpose other than government procurement does not in any way obligate the U.S. Government. The fact that the government formulated or supplied the drawings, specifications, or other data does not license the holder or any other person or corporation; or convey and rights or permission to manufacture, use, or sell any patented invention that may relate to them.

This report has been reviewed by the Office of Public Affairs (ASC/PA) and is releasable to the National Technical Information Service (NTIS). At NTIS, it will be available to the general public, including foreign nations.

This technical report has been reviewed and is approved for publication.



DAVID BANASZAK  
Project Engineer  
Analytical Structural Mechanics Branch  
Structures Division



GERALD PLZAK  
Technical Manager  
Analytical Structural Mechanics Branch  
Structures Division



JEROME PEARSON  
Chief  
Analytical Structural Mechanics Branch  
Structures Division

Copies of this report should not be returned unless return is required by security considerations, contractual obligations, or notice on a specific document.

## CONTENTS

I	INTRODUCTION . . . . .	1
II	DATA PACKAGE . . . . .	3
II.A	INSTRUMENTATION DESCRIPTION . . . . .	3
II.B	SENSOR INSTALLATION . . . . .	4
II.C	SYSTEM CALIBRATIONS . . . . .	7
II.D	AIRCRAFT DATA RECORDING SYSTEM . . . . .	9
II.E	VAN TEST INSTRUMENTATION . . . . .	10
III	TEST PROCEDURES . . . . .	12
IV	DATA ANALYSIS . . . . .	14
V	RESULTS . . . . .	15
VI	CONCLUSIONS . . . . .	18
VII	REFERENCES . . . . .	19

### APPENDIX A TABLES

A.1	TABLE I A-7D FLIGHT TEST INSTRUMENTATION PARAMETER LIST . . . . .	A-2
A.2	TABLE II A-7D HAVE BOUNCE LIST OF EQUIPMENT AND SENSORS . . . . .	A-3
A.3	TABLE III LOG OF TAPE RECORDS . . . . .	A-4
A.4	TABLE IV CALIBRATION TABLE . . . . .	A-7
A.5	TABLE V LEACH TAPE TRACK ASSIGNMENTS . . . . .	A-7
A.6	TABLE VI A7-D HAVE BOUNCE PCM FORMAT . . . . .	A-8
A.7	TABLE VII A-7D AIRCRAFT TEST CONFIGURATIONS . . . . .	A-9
A.8	TABLE VIII LANDING GEAR LOAD LIMITS . . . . .	A-9
A.9	TABLE IX A-7D HAVE BOUNCE TEST RUNS . . . . .	A-10
A.10	TABLE X EQUATIONS FOR DERIVED QUANTITIES . . . . .	A-11
A.11	TABLE XI PLOT FORMATS . . . . .	A-12
A.12	TABLE XII MAXIMUM AND MEAN VERTICAL LOADS FOR NOSE AND MAIN GEAR . . . . .	A-13

### APPENDIX B FIGURES

B.1	FIGURE 1 DIAGRAM A-7D PORTABLE DATA ACQUISITION PACKAGE . . . . .	B-2
B.2	FIGURE 2 BLOCK DIAGRAM MOBILE DATA ACQUISITION AND ANALYSIS VAN . . . . .	B-3
B.3	FIGURE 3 INSTRUMENTATION LOCATIONS ON THE A-7D . . . . .	B-4
B.4	FIGURE 4 WIRING FROM ACCELEROMETERS TO SIGNAL CONDITIONING . . . . .	B-5
B.5	FIGURE 5 WIRING FROM NOSE LANDING GEAR TO SIGNAL CONDITIONING . . . . .	B-6
B.6	FIGURE 6 WIRING FROM LEFT LANDING GEAR TO SIGNAL CONDITIONING . . . . .	B-7
B.7	FIGURE 7 WIRING FROM RIGHT LANDING GEAR TO SIGNAL CONDITIONING . . . . .	B-8
B.8	FIGURE 8 SIGNAL CONDITIONING IN RIGHT HAND AVIONICS BAY . . . . .	B-9
B.9	FIGURE 9 DATAMETRICS TIME CODE GENERATOR . . . . .	B-10
B.10	FIGURE 10 POWER CUBE POWER SUPPLY BOX . . . . .	B-11
B.11	FIGURE 11 LOCKHEED/LEACH TAPE RECORDER . . . . .	B-12

B.12	FIGURE 12 MODEL 7-128A PROGRAMMABLE DATA ACQUISITION SYSTEM . . . . .	B-13
B.13	FIGURE 13 PCM DECODER BOX . . . . .	B-14
B.14	FIGURE 14 BASIC PRESSURE TRANSDUCER FITTINGS . . . . .	B-15
B.15	FIGURE 15 AMPLIFIER BOX AND SCHEMATIC . . . . .	B-16
B.16	FIGURE 16 BRIDGE BALANCE AND SHUNT CAL CIRCUITS . . . . .	B-17
B.17	FIGURE 17 NOSE GEAR STRING POT MOUNTING . . . . .	B-18
B.18	FIGURE 18 MAIN GEAR LVDT MOUNTED . . . . .	B-19
B.19	FIGURE 19 LVDT VOLTAGE DIVIDER . . . . .	B-20
B.20	FIGURE 20 WHITEMAN AFB, MO A-7D HAVE BOUNCE TEST GENERAL LOCATIONS . . . . .	B-21
B.21	FIGURE 21 PROPOSED BUMP PROFILES . . . . .	B-22
B.22	FIGURE 22 BUMP PROFILES AS TESTED . . . . .	B-23
B.23	FIGURE 23 DATA REDUCTION PROCEDURE . . . . .	B-24
B.24	FIGURE 24 PAGE ONE OF RUN NO. 34 . . . . .	B-25
B.25	FIGURE 25 PAGE TWO OF RUN NO. 34 . . . . .	B-26
B.26	FIGURE 26 PAGE THREE OF RUN NO. 34 . . . . .	B-27
B.27	FIGURE 27 PAGE FOUR OF RUN NO. 34 . . . . .	B-28
B.28	FIGURE 28 PAGE FIVE OF RUN NO. 34 . . . . .	B-29
B.29	FIGURE 29 PAGE SIX OF RUN NO. 34 . . . . .	B-30
B.30	FIGURE 30 LOAD VS. VELOCITY, LANDING WT., SPALL PROFILE . . . . .	B-31
B.31	FIGURE 31 LOAD VS. VELOCITY, TAKE-OFF WT., SPALL PROFILE . . . . .	B-32
B.32	FIGURE 32 LOAD VS. VELOCITY, LANDING WT., 1-3" BUMP PROFILE . . . . .	B-33
B.33	FIGURE 33 LOAD VS. VELOCITY, TAKE-OFF WT., 1-3" BUMP PROFILE . . . . .	B-34
B.34	FIGURE 34 LOAD VS. VELOCITY, LANDING WT., 2-3" BUMP PROFILE . . . . .	B-35
B.35	FIGURE 35 LOAD VS. VELOCITY, TAKE-OFF WT., 2-3" BUMP PROFILE . . . . .	B-36
B.36	FIGURE 36 PAGE FIVE OF RUN NO. 22 . . . . .	B-37
B.37	FIGURE 37 TIME HISTORY OF SLOAD1 AND SLOAD2 . . . . .	B-38
B.38	FIGURE 38 TIME HISTORY OF SLOAD3 AND SLOAD4 . . . . .	B-39
B.39	FIGURE 39 TIME HISTORY OF SLOAD5 AND SLOAD6 . . . . .	B-40
B.40	FIGURE 40 LOAD VERSUS STROKE CURVE FOR MAIN LANDING GEAR STRUTS . . . . .	B-41
B.41	FIGURE 41 LOAD VERSUS STROKE CURVE FOR NOSE LANDING GEAR STRUTS . . . . .	B-42

APPENDIX C      PHOTOGRAPHS

C.1	PHOTO 1 A-7D TAXING OVER MAT . . . . .	C-2
C.2	PHOTO 2 A-7D BEING TOWED WITH AVIONICS BAY DOOR OPEN . . . . .	C-2
C.3	PHOTO 3 PORTABLE DATA ACQUISITION PACKAGE EXTENDED FROM AVIONICS BAY . . . . .	C-3
C.4	PHOTO 4 PORTABLE DATA ACQUISITION PACKAGE IN AVIONICS BAY . . . . .	C-3
C.5	PHOTO 5 TELEMETRY ANTENNA ON TOP OF A-7D . . . . .	C-4
C.6	PHOTO 6 FIBG VAN AT WHITEMAN AFB, MO . . . . .	C-4
C.7	PHOTO 7 NOSE GEAR SENSOR P1 . . . . .	C-5
C.8	PHOTO 8 NOSE GEAR SENSORS P2 AND DP1 . . . . .	C-5

C.9	PHOTO 9 LEFT GEAR SENSOR P3 . . . . .	C-6
C.10	PHOTO 10 LEFT GEAR SENSORS P4 AND DP2 . . . . .	C-6
C.11	PHOTO 11 LEFT GEAR SENSOR P5 . . . . .	C-7
C.12	PHOTO 12 RIGHT GEAR SENSORS P6, P7 AND P8 . . . . .	C-7
C.13	PHOTO 13 C.G. ACCELEROMETER A1 . . . . .	C-8
C.14	PHOTO 14 RIGHT WING ACCELEROMETER A6 . . . . .	C-8
C.15	PHOTO 15 PILOT'S STATION ACCELEROMETER A2 . . . . .	C-9
C.16	PHOTO 16 NOSE GEAR SENSORS SG1 AND DP1 . . . . .	C-9
C.17	PHOTO 17 NOSE GEAR DRAG STRUT STRAIN GAGE SG2 . . . . .	C-10
C.18	PHOTO 18 LEFT GEAR SHOCK STRUT STRAIN GAGE SG3 . . . . .	C-10
C.19	PHOTO 19 LEFT GEAR DRAG STRUT STRAIN GAGE SG4 . . . . .	C-11
C.20	PHOTO 20 RIGHT GEAR SENSORS SG5, SG6, DP3, AND RPM2 . . . . .	C-11
C.21	PHOTO 21 LEFT GEAR AIRCRAFT PROXIMITY SENSOR RPM1	C-12

APPENDIX D      RUNWAY SURVEY LOG

## FOREWORD

This project was accomplished thru the combined efforts of the Structural Vibration and Acoustics, and the Structural Integrity Branches of the Structures and Dynamics Division, Flight Dynamics Laboratory, Air Force Wright Aeronautical Laboratory, Wright Patterson Air Force Base, Ohio. The work was initiated under Project 20545001 Support of HAVE BOUNCE. Other participants included ASD/TA, 132nd TFW ANG, and AFFTC. The work was requested by AFWAL/FIBE, Capt. Bob Knarr in November, 1984 and continued by Mr. John Riechers.

The HAVE BOUNCE Program Manager was Mr. Earl Ashworth of ASD/TAAM, Program Engineer, Mr. Jim Holpp of ASD/TAEF and Test Manager, Lt. Michael Richards of ASD/TAAT. AFFTC was the Responsible Test Organization and provided AFWAL with the telemetry transmitter, receiver and antenna used for the test.

This work was performed by Mr. David Banaszak, Mr. Earl Rogers, Mr. Dansen Brown, Mr. Vincent Johnson, Mr. Larry Dukate and Mr. Mike Hart of AFWAL/FIBG and Mr. John Riechers of AFWAL/FIBE during the period of October, 1984 to March, 1985. The manuscript was released in December, 1985 as an AFWAL Technical Memorandum.

The authors wish to extend their appreciation to Mr. Lowell Vaughn and Mr. Mike Hart who were responsible for the acquisition and the reduction of the measured data and to Mike Banford for supplying drawings for the instrumentation. We would also like to acknowledge the tremendous effort of Mr. Fred Hussong and all other persons from AFWAL/FIBT involved in instrumentation and calibration of the main and nose landing gear for this project. Special thanks go to the Air National Guard personnel whose efforts and cooperation were essential in all phases of the testing. In particular we thank Col. James M. Fredregill, Maintenance Chief, TSgt. Paul Carder, Crew Chief, and the other members of the Des Moines ANG.

The Technical Memorandum has been reviewed and approved by:



DAVEY L. SMITH, Chief  
Structural Vibration and Acoustics  
Branch, Structures and Dynamics  
Division



FRANK D. BOENSCH, Chief  
Structural Integrity  
Branch, Structures and  
Dynamics Division

## LIST OF SYMBOLS AND ABBREVIATIONS

SYMBOL/ABBREVIATION	- MEANING
AFB	Air Force Base
AFFTC	Air Force Flight Test Center
AFWAL	Air Force Wright Aeronautical Laboratories
ANG	Air National Guard
ASD	Aeronautical Systems Division
BCD	Binary Coded Decimal
c.g.	Center of Gravity
D/A	Digital to Analog
FM	Frequency Modulation
g	Acceleration of 9.80 meters/second square
HAVE BOUNCE	Project under Rapid Runway Repair Program
ips	Inches Per Second
IRIG-B	Inter Range Instrumentation Group-B
KIPS	Thousand Pounds
LTV	Ling Tempco Vought, Corporation
LVDT	Linear Variable Differential Transformer
MDAAV	Mobile Data Acquisition and Analysis Van
MHZ	Mega Hertz
PCM	Pulse Code Modulation
PDAP	Portable Data Acquisition Package
PSIA	Pounds Per Square Inch Absolute
PSIG	Pounds Per Square Inch Gauge
R <sub>g</sub>	Gain Resistor
RPM	Revolution Per Minute
SG	Strain Gage
SLOAD	Strut Load
TM	Telemetry
VDC	Volts Direct Current
V <sub>out</sub>	Voltage Out
WPAFB	Wright-Patterson Air Force Base
132 TFW	132nd Tactical Fighter Wing

## I INTRODUCTION

Early military aircraft were designed for operations off rough and unprepared surfaces. During the Second World War the use of paved and semiprepared airfields allowed designs to use smaller and lighter landing gear components improving aircraft performance and ordnance delivery capabilities. This dependence upon prepared surfaces did increase the maintenance time necessary on forward airfields. After the war the Air Force adopted the philosophy of operating aircraft primarily from paved runways. The Korean and Vietnam conflicts demonstrated the vulnerability of this resource. At this time several methods of repairing damaged runways were developed but all demonstrated the inverse proportionality of smoothness to repair time. The need to rapidly resume aircraft operations after being attacked necessitates the acceptance of runway roughness.

The HAVE BOUNCE program was initiated to quantify the capabilities of U.S. aircraft over rapidly repaired runway surfaces. All primary front line aircraft have been tested under this program and computer models of their response to runway roughness completed. The test described in this report is on the A-7D aircraft and is to provide data to verify computer models developed by the LTV Vought Corporation and the Air Force (AFWAL/FIBE).

The A-7D test aircraft is a single-engine, single-place, attack aircraft operated by the Navy and Air National Guard and manufactured by Vought Corporation Dallas, Texas. Aircraft tail number 75-0397 was instrumented to measure gear and aircraft loads for HAVE BOUNCE. The 132nd Tactical Fighter Wing (132nd/TFW), Iowa Air National Guard (ANG) supplied, maintained and piloted the aircraft. The 132nd/TFW also

helped modify the aircraft at the Des Moines ANG Base, Iowa. For flight safety, the modified A-7D was flown at a maximum speed of 250 knots with gear locked down from Des Moines to Whiteman AFB, MO for the ground testing.

The aircraft was taxied over three repair configurations during light and heavyweight operations. The configurations were a single bump, a double bump and a spall as described in Section III. A typical taxi run of the A-7D over a bump is shown in Photo 1. The test runs were recorded on magnetic tape and oscillograph paper.

This report documents the instrumentation, procedures and data analysis used for the A-7D HAVE BOUNCE tests conducted at Whiteman AFB, MO during December 1984. Section II describes the instrumentation package. Section III gives the test procedures and describes the testing techniques. Data reduction procedures are described in Section IV and results are presented in Section V, including sample data. Section VI are the Conclusions from this program. AFWAL-TM-85-257-FIBG (Reference 2) contains time histories from the measured parameters for all test events of this program.

## II DATA PACKAGE

### II.A INSTRUMENTATION DESCRIPTION

The instrumentation consisted of two parts shown in the block diagrams of Figures 1 and 2. A portable data acquisition package was fabricated and installed in the aircraft. A van was driven to Des Moines for the aircraft modification and then driven to Whiteman for the test. The van was on-site for a quick-look at recorded data and real time monitoring of telemetered information. The A-7D drawing in Figure 3 shows the location of the transducers and Table I gives their identification(ID) numbers.

Table II lists the instrumentation components. Photos 2 thru 4 show the portable data acquisition package in the aircraft's right hand avionics compartment located between fuselage stations 361.5 and 383.5. The Doppler Radar Unit was removed from this compartment. The tape recorder, digital encoder and signal conditioning were powered from the secondary 28 VDC bus located in the avionics compartment circuit breaker panel. A 10 amp circuit breaker was installed on the panel and power cables were routed to the package. On the package, the 28 VDC power was distributed to the pressure transducers. A power supply converted 28 VDC to (+)/(-)15VDC required for signal conditioning, linear displacement sensors and accelerometers. The 28 VDC also powered a telemetry transmitter.

Power and signal cables from each transducer were routed to the avionics compartment. Cables on the outside skin were covered with aluminum tape to ensure cable security for subsequent flights(See Photo 2). The cables for the nose and main landing gears were routed

through a potted feed-thru in the aft, inboard, lower corner of the right hand avionics compartment. Wiring between transducers and the signal conditioning are shown in Figures 4, 5, 6, and 7.

As shown in Figure 8, all the mechanical components were mounted on a 1/4 inch thick Aluminum plate. The plate was attached by means of four 5/16-18 1/2 inch long bolts using existing holes in the lower equipment shelf. Mechanical drawings of the time code generator, power cube, recorder, PCM encoder and PCM decoder are included as Figures 9 thru 13. The telemetry transmitter was attached to a aluminum plate to provide a heat sink and then installed on the shelf above the acquisition package. The transmitter antenna was mounted on top of the aircraft as shown in Photo 5. A switch box and microphone were located in the cockpit for controlling the tape recorder and recording the pilot's voice on tape.

In addition to recording test data onboard the aircraft, a Mobile Data Acquisition and Analysis Van was used at Whiteman AFB for quick look at recorded data after each test run (See Photo 6). The van housed a telemetry receiver for reception of PCM data during the tests. Van equipment listed in Table II included tape recorders, a PCM decoder system (including D/A converters) and a multichannel oscillograph recorder. The van playback capability is shown in Figure 2.

## II.B SENSOR INSTALLATION

Six transducers were used to measure the hydraulic cylinder pressures of the upper and lower chambers on all the landing gear shock struts. Two transducers were used to measure the brake

pressures of the main gear. The pressure transducers chosen were Teledyne Taber Model 2403's with a range of 0 to 5000 psig. The Shrader valves used to service the upper and lower chambers of the shock struts were removed and replaced by special fittings. The fittings were designed to allow use of the Shrader valve and the pressure transducer simultaneously. One fitting on the upper chamber of the nose gear had to be reworked to fit the available space. Figure 14 shows the basic fitting design. Photos 7 thru 12 show pressure transducers P1 thru P8 mounted on the gear. The transducers were powered by 28 VDC. The outputs were wired to a 0-5 VDC channel of the PCM encoder.

The transducers used to measure the accelerations were Setra Systems, Inc. Model 141A Linear Accelerometers. For wing and c.g. accelerometers five small mounting plates with four tapped holes were bonded directly to the surfaces using Loctite Depend Adhesive (See photos 13 and 14 for A1 and A6). For the pilot seat accelerometer, A2 in Photo 15, a block with four tapped mounting holes was bonded to the structure. The six accelerometers were screwed to the tapped holes.

Since the accelerometer's output had some feedthru of its 20 MHz operating frequency, there was possible aliasing in the sampled data. A fixed gain amplifier was designed to filter the 20 MHz and amplify the accelerometer's output. An amplifier gain of five was used to increase the accelerometer's output to a level compatible with the input of the PCM encoder.

The amplifier is powered by +15 and -15 VDC and can be used with a multitude of transducers. The inputs can be configured as AC or DC coupled; also single ended or differential. The amplifier also has a

choice of four fixed gain stages, nominally(x1,x10,x100,x1000). By changing one resistor almost any fixed gain can be obtained. The amplifier contains a Datel AM201-C Operational Amplifier with an input impedance of one gigaohm(1E+09). See Figure 15 for basic amplifier size and schematic. The compact amplifier box lent itself well to a stacking concept. This compact, stackable design was essential for the test since equipment space onboard the A-7D was minimal.

The strain gages used were Micro-Measurements EA-06-125PC-350 and EA-06-125PC-1000. Six strain gage pairs on the landing gear components were preinstalled and calibrated at WPAFB,OH. Strain gages SG1 thru SG6 located on the gears are shown in Photos 16 thru 20. The strain gaged landing gear components were delivered to ANG personnel at Des Moines for installation onto the aircraft.

An excitation voltage of +5 to - 5VDC was applied across the four active arm bridges. In order to balance the bridge, the network shown in Figure 16 was fabricated. A calibration resistor shunting the negative output leg with a known resistance was used as shown in the figure. A passive RC antialiasing filter was installed on each strain gage output.

An electrical signal proportional to wheel revolutions per minute(RPM) was measured with the proximity probe on each main gear. The proximity probe on the left main gear is shown in Photo 21. The probe's signal was obtained from the aircraft's anti-skid box and used to derive ground speed. The output of the proximity probes were input to Frequency Devices Model 451K Frequency to Voltage converter and then digitized by the PCM encoder. Also, the analog output from each proximity probe was recorded on the aircraft recorder. A capacitor

blocked the 4 VDC level on the proximity sensor output.

Two type of sensors measured gear displacement(stroke), a Model 5000 HDD Linear Variable Differential Transformer(LVDT) and a Model 1800-05A String Potentiometer. The String Potentiometer mounting is shown in Figure 17 and as DP1 in Photo 16. The LVDTs were mounted to the main landing gear using specially designed brackets as shown for DP2 and DP3 in Photos 10 and 20. A LVDT on a main gear is also shown in Figure 18. The output voltage of the LVDT was +5 to -5 VDC for +5 to -5 inches (10 inch overall) and was divided as shown in Figure 19 to interface to the PCM encoder. The string pot had an output of 0 to 5 VDC for an extension of 0 to 20 inches.

### II.C SYSTEM CALIBRATIONS

In the field, a DC standard voltage reference was applied to all the 5V, -2.5 to +2.5V and -10mv to +10mv channels of the encoder as shown by tapes 0 and 1 in Table III. These records were used to check the encoder linearity. Field calibrations were first derived from transducers and signal conditioning specifications. End to end field calibrations were performed on some transducers and documented on tapes 2-6.

After test completion, the standard voltages and the recorded counts on tape were used to determine volts/counts and volts offset for each of the channels by using a linear regression BASIC program on a microcomputer. The counts recorded for the known engineering inputs were determined by taking two seconds of a static calibration record. Maximum, minimum and mean values of counts were used to derive the final calibrations summarized in Table IV.

A deadweight tester was used on the pressure transducers to get output voltage versus input psig. Some transducers were tested to 7000 psig and found to be linear beyond the specified 5000 psig. Linear regression was used to get sensitivity in psig/volts and offset. Psig/counts were obtained by combining the volts/counts from the standard voltage input calibrations with the deadweight calibration. A voltage divider was designed for use with strut pressure transducers on the main gear to divide the 7 volts at 7000 psig to 4.67 volts at 7000 psig. After demodification, the voltage divider resistors were not found. Hence some of the pressure data were clipped. An end to end pressure calibration would have caught this oversight, but this was not possible without a precision reference pressure gage with a range beyond 1000 psig.

The calibrations for the accelerometers were obtained by a three point static cal in the field. The two "g" change from +1g to -1g was used with the counts recorded on tape to derive counts/g. The values obtained compared well with calibrations using the accelerometer specification and the 2.5 VDC standard reference encoder records.

Several calibration checks were made of the strain gages. Before departure to Des Moines, calibration data were provided for each of the six gages. The initial calibrations provided coarse results in the field. The gages were recalibrated after the struts were removed from the aircraft. Combining the Kips/mv sensitivity for each of the six gages with the mv/counts sensitivities of each strain gage encoder channel, the calibrations showed in Table IV were derived. Throughout the testing, records were made with the aircraft on jacks to check the zero load output of the strain gages.

To measure aircraft speed the main gear proximity probes were connected to a field designed frequency/voltage converter. The converter was calibrated in terms of Hertz/volt. This information was combined with the encoder's volts/count to get Hertz/count. Since there were 90 slots on the aircraft wheel to interrupt the magnetic field of the proximity probe, each full tire rotation created 90 cycles of induced voltage. The following relationship converted the "f" cycles from the proximity probes to knots.

$$\text{Knots} = \frac{f \text{ cycles}}{1 \text{ seconds}} \times \frac{1 \text{ revolution}}{90 \text{ cycles}} \times \frac{7.2 \text{ feet}}{1 \text{ revolution}} \times \frac{1 \text{ Knot}}{1.689 \text{ (feet/second)}}$$

or Knots = 0.047365304 f ; where tire circumference = 7.2 feet

Gear displacement calibrations were recorded on tapes 2 and 3 as shown in Table III. The airplane was jacked up at each gear to a known strut displacement. The amount of strut chrome showing was recorded on paper and a PCM decoder box shown in Figure 13 was used to read counts to the recorder. Later, the recorded data were used with a linear regression program to derive the calibrations shown in Table IV. A post test calibration showed good comparison with the initial calibrations.

#### II.D AIRCRAFT DATA RECORDING SYSTEM

As shown in Figure 1, the transducer outputs were conditioned before input to the PCM encoder. In the PCM encoder, each signal was sampled, digitally encoded into 12 bit words, and time division multiplexed into a serial digital bit stream at 150 kilobits per second. The analog IRIG-B output of the time code generator was

recorded on the aircraft tape recorder. Also, the BCD output from the time code generator was input into the encoder for inclusion in the PCM data signal. Digital time code was also multiplexed into the PCM data for ease in generating time history plots.

Data for each test run were recorded on the Leach aircraft tape tracks shown in Table V. In addition, the PCM data signal from the encoder was routed to the telemetry transmitter for modulation and transmission to the van.

Table VI shows the format of the PCM data and the resulting sampling rates for each transducer. The strain gage and accelerometer calibrations using shunt calibration resistors were recorded at the beginning and end of each aircraft tape.

## II.E VAN TEST INSTRUMENTATION

The Mobile Data Acquisition and Analysis Van was used for quick look of direct telemetered data and telemetered data recorded on a tape recorder. The van was also used to playback aircraft data tapes.

For each test run, the receiver in the van was tuned to the transmitter's frequency of 1483 MHz. The demodulated Bi-Phase-L PCM data were recorded on a single track of the Honeywell 101 tape recorder and paralleled into the EMR 708 PCM playback system. Nineteen selected critical measurements were routed from the PCM playback system's D/A converter to two Honeywell 1858 oscillograph recorders. The oscillograph time histories were evaluated before proceeding to the next test condition. The tape recorder reproduce output was also input into the EMR system for real time plots of recorded telemetered data. Records of telemetered(TM) data, recorded

on the Honeywell 101 tape at a speed of 30 ips, are included in Table III.

The aircraft tapes were played back on a Honeywell 96 tape recorder in the van. The PCM output was input into the playback system for quick look at time histories on oscillograph recorders. Calibration records on the aircraft tape were not usually present on the telemetered data because the cals were not inserted when the telemetry recordings were made.

As shown in the van's block diagram in Figure 2, a printer provided hard copy of static parameter readings displayed on the EMR 708's CRT. This aided in checking calibration points during tape playback.

### III TEST PROCEDURES

All testing was performed at Whiteman AFB, Missouri between 12 December and 19 December, 1984. Figure 20 shows the layout of the base with the positions of all points of primary interest identified. Bumps were placed off centerline to allow the maximum emergency capability of the airfield.

The proposed bump and spall profiles are shown in Figure 21. Bumps were created by laying two AM2 mats, one on top of the other. These bumps were fifty-two (52) feet wide and a temporary centerline was painted for the pilots use. As indicated by the runway survey log in Appendix D, the end to beginning bump spacing was closer to eighty-two (82) rather than the desired seventy (70) feet. The proposed spalls were to have six (6) inch ramps leading into, and out of, a one and one-half (1 1/2) inch deep by one (1) foot long trough. The actual spall was cut with a much rounder profile. Figure 22 depicts the actual bumps and spalls as tested.

The two test aircraft configurations were a maximum gross weight takeoff and a typical landing weight. Table VII provides a complete description of these two configurations. All aircraft maintenance and servicing were checked periodically to verify compliance with Technical Order specifications.

Aircraft staging, fueling, and configuration alterations were performed at the access ramp at the South end of the runway. All test runs were made from the South to the North to take advantage of the rise in elevation at the North end of the runway and prevailing winds for post test deceleration. For a typical run, the pilot taxied the aircraft to the South end of the runway, turned on the on-board data

recorder, accelerated to and stabilized at the target test velocity as indicated by his ground speed indicator, traversed the test bump, decelerated using minimum braking techniques, turned off the recorder, and returned to the South end of the runway. The use of minimum braking techniques prompted the pilot to cause full elevator deflection within one to two seconds after exiting the test bumps.

For each test run data were recorded on the Leach Recorder on-board the aircraft and telemetered to the van for recording on a Honeywell 101. Recorded test runs are indicated in Table III. Telemetered data were monitored inside the van and aircraft tapes were changed as required. Twenty-four (24) hour power to the van provided minimal warmup requirements at the beginning of each day.

Safety and data requirements necessitated a build-up approach in aircraft loads. This was accomplished by running low before high speeds, single before double bumps, and light before heavy weight aircraft. Table VIII lists the test limits. Wheel and brake temperatures were monitored between test points to prevent overheating of the system. AFFTC, the Responsible Test Organization (RTO), retained the final decision on when to proceed from one test point to the next.

#### IV DATA ANALYSIS

The PCM data recorded on analog tapes were analyzed at the Dynamics Data Analysis Facility using the procedure shown in Figure 23. The selected data for the conditions listed in Table IX were played back through PCM decoders and stored on digital magnetic tape for computer processing.

The Raytheon computer system was used to apply the gain-corrected calibration factors to the various transducers( accelerometers, pressure transducers, load cells, strain gages, and displacement transducers), to insert data identification, and to reformat the digital tapes into the VAX computer format for further processing. The transducer identifications and locations are listed in Table I, with the corresponding calibration parameters given in Table IV.

The VAX computer system was used to plot time histories of the measured data and derived quantities, along with relevant statistics (maximum, minimum, mean, and rms values). The equations for the derived quantities are given in Table X. For each test condition the results were plotted in the six formats given in Table XI.

## V RESULTS

The run numbers identified in Table IX are referenced to this report and not necessarily comparable to any identification used during the test. The aircraft configuration is either a take-off or landing. The bump is identified as 1-3 for one three inch high bump, 2-3 for two bumps, and spall for a spall run. Fuel weight reflects the pilot's reading at the time of obstacle encounter. In the landing configuration 1,800 pounds of fuel gives a total aircraft weight of 24,520 pounds. For a take-off 6,350 pounds of fuel results in a 42,000 pound aircraft. Target and actual velocities are in knots ground speed. All tests were conducted during December, 1984, therefore, the date is the day of the month. The normal test was run at a constant velocity, 5 degree leading edge down horizontal stabilizer setting and 100 psig nose tire pressure. The notes in Table IX identify any deviation from these normal conditions.

A complete set of time history plots for all parameters is presented in AFWAL-TM-85-257(Reference 2). There are six pages with four plots per page for each test condition. A typical set of plots for one test condition are presented in Figures 24 to 29. A parameter time-history is identified by a run number, page of that run and plot number, top to bottom, on the page. For example: plot no. 3, page 4 of run number 34 is a time history of the right main gear drag brace load in pounds (SG 6) for a 40,450 pound A-7D traversing a single 3 inch high bump at 61 knots. Table XI defines all 24 plots for each run.

Table XII summarizes the maximum and mean loads for the nose, left, right and average main landing gear vertical loads. The average

main landing gear vertical load is an instantaneous value and therefore its maximum will not be the same as the average of maximums, as these need not occur simultaneously. The maximum loads are plotted against velocity in Figures 30 to 35, separated according to aircraft and bump configuration. The inflection of the nose gear load curve in Figure 32 demonstrates the load alleviation capability of aerodynamic lift. The 50% increase in load carrying capability of the 185 psig nose tire (Table VIII) gives a substantial increase in aircraft performance in spite of the slightly higher loads indicated in Figure 33 and Figure 35. Figure 33 shows very small load changes due to changes in the elevator setting between 5 degrees and 8 degrees.

Figure 36 which is page 5 of run number 22 demonstrates the pilot's influence on the aircraft response. Plot 1 shows that within two seconds after encountering the bump, the pilot has directed sufficient elevator motion to lift the nose landing gear off of the pavement.

Figures 37 to 39 present a comparison of strut loads as calculated from the strain gauge bridges to those from the pressure transducers for run number 34 (Take-off weight, single bump, 60 knots). Strut load (SLOAD) 1, 3 and 5 are derived from the strain gauge bridges. SLOAD 2, 4 and 6 are derived by multiplying the pneumatic pressure by the pneumatic area and adding the quantity of the pneumatic minus the hydraulic pressures times the hydraulic area. Figure 37 for the left main landing gear strut load indicates very good agreement between the two calculation methods. Figure 38 for the right main landing gear strut load shows good overall agreement of SLOAD 3 and SLOAD 4 and a maximum difference of about 10%. Figure 39 for the nose landing gear strut load indicates nearly a constant

offset between SLOAD 5 and SLOAD 6, with the offset changing sign during extreme motion of the strut. The sign change in the nose gear load offset suggests that it is probably caused by friction in the strut, which is a contributor to SLOAD 5 but discounted in SLOAD 6. The semi-levered design of the nose landing gear would cause significant binding in the strut. These comparisons indicate sufficient accuracy in all gear loads data. The most error prone data are from the right main landing gear with a maximum error of about 10% of the measured value.

Figures 40 and 41 are plots of the main and nose gear test and theoretical load vs. stroke. Figure 40 indicates little correlation between either the left or right main gear experimental data and the theoretical load-stroke curve. An explanation for this is that if precharge nitrogen were absorbed into the hydraulic oil, then the effect would be to reduce the nitrogen precharge pressure, which would also increase the oil volume and thus reduce the effective residual volume at full compression. Both the left and right gear curves display this type of displacement from the theoretical. This would suggest that in computer models of this landing gear, the use of an effective volume and precharge pressure instead of the theoretical values will provide more realistic results. SLOAD 5, strain gauge loads data, in Figure 41 follows the shape of the theoretical curve very well. SLOAD 6 on this plot includes the effects of hydraulic damping. The breadth of SLOAD 5, as compared to that of SLOAD 6 for a given strut stroke, quantifies the frictional forces in this strut. These high frictional values must be included in a computational model of this strut to obtain any degree of accuracy.

## VI CONCLUSIONS

1. The data generated by this test program are sufficiently consistent and accurate for use in verifying computer simulation techniques. The only exceptions to this are the data from spall profile encounters and braking runs.
2. The total instrumentation package performed well. Filters for the accelerometer transducers would have provided cleaner signals.
3. The use of "realistic" versus the theoretical strut surfacing for the main landing gear in computer simulations will improve the correlation to the real world.
4. Nose landing gear strut friction must be included in a computational model of this aircraft.
5. The use of increased elevator deflection (8 degrees vs 5 degrees) does not significantly alter the nose landing gear loads for the heavy weight aircraft at the velocities tested.
6. For this aircraft, with small strut friction, the main landing gear strut loads could be calculated from pressure loads alone, negating the need for complex strain gauge bridges on these members.
7. Nose gear loads for landing weight braking runs are consistently lower than the corresponding heavy weight constant speed runs. Therefore, obstacles which are acceptable for maximum gross weight takeoffs will also be acceptable for "normal" landings.
8. The use of increased nose landing gear tire pressures can significantly extend the capabilities of this aircraft.

## VII REFERENCES

1. LTV Vought, Transmittal of Data to Wright-Patterson AFB, OH45433, Transmittal Number 2-5122014L-324, 3 October 1984.
2. AFWAL-TM-257-85, A7D HAVE BOUNCE Test Data, Banaszak, Brown and Riechers, December 1985.

APPENDIX A

TABLES

A.1 TABLE I A-7D FLIGHT TEST INSTRUMENTATION PARAMETER LIST

No.	Instrumentation	Calibration Range	Frequency Response	Req Acc. %	Transducer ID	Serial Number
1.*	Nose Gear Knee Link Axial Load (B1)	100,000 LB. Tension	50 HZ	5	SG1	
2.*	Nose Gear Drag Strut Axial Load (B2)	20,000 LB. Tension 77,000 LB. Comp	50 HZ 50 HZ	5 5	SG2	
3.	Nose Gear Shock Strut Upper Pressure	4,000 PSI	20 HZ	5	P1	793333
4.	Nose Gear Shock Strut Lower Pressure	4,000 PSI	20 HZ	5	P2	793334
5.	Nose Gear Shock Strut Stroke	0 to 11 Inches	20 HZ	2	DP1	4896-008
6.*	LMG Shock Strut Axial Load (B2)	50,000 LB. Comp	100HZ	5	SG3	120MKA
7.*	LMG Drag Strut Axial Load (B1)	45,000 LB.Tens/Com	100HZ	5	SG4	1761
8.	LMG Shock Strut Upper Pressure	7,000 PSI	20 HZ	5	P3	823657
9.	LMG Shock Strut Lower Pressure	7,000 PSI	20 HZ	5	P4	823655
10.	LMG Shock Strut Stroke	0 - 8 Inches	20 HZ	2	DP2	451
11.*	RMG Shock Strut Axial Load(B1)	150,000 LB.Comp	100HZ	5	SG5	243HCA
12.*	RMG Drag Strut Axial Load(B1)	45,000 LB.Tens/Com	100HZ	5	SG6	2092
13.	RMG Shock Strut Upper Pressure	7,000 PSI	20 HZ	5	P6	781044
14.	RMG Shock Strut Lower Pressure	7,000 PSI	20 HZ	5	P7	823749
15.	RMG Shock Strut Stroke	0 - 8 Inches	20 HZ	2	DP3	455
16.*	Normal Accel(G) at CG	-10 to +10 G	50 HZ	5	A1	75858
17.	Normal Accel (G) at Pilots Seat	-10 to +10 G	50 HZ	5	A2	75864
18.	Normal Accel (G) at Wing Tip	-10 to +10 G	20 HZ	5	A3	75857
19.*	Normal Accel (G) at Wing Fold	-10 to +10 G	20 HZ	5	A4	75854
20.*	Normal Accel (G) at Mid Outer Panel	-10 to +10 G	20 HZ	5	A5	75859
21.*	Normal Accel (G) at Center Pylon	-10 to +10 G	20 HZ	5	A6	75860
22.*	LMG Wheel RPM	0 to 2500 RPM	100HZ	5	RPM1	
23.	RMG Wheel RPM	0 to 2500 RPM	100HZ	5	RPM2	
24.	RMG Brake Pressure	0 to 1200 PSI	20 HZ	5	P8	823750
25.	LMG Brake Pressure	0 to 1200 PSI	20 HZ	5	P5	823656

NOTES:

1. Frequency response of continuous analog data.
2. \* indicated safety parameter (GO - NO GO).
3. For strain gages B1 is Bridgel and B2 is Bridge 2.
4. RMG=Right Main Gear LMG=Left Main Gear

A.2 TABLE II A-7D HAVE BOUNCE LIST OF EQUIPMENT AND SENSORS

QUANTITY	MANUFACTURER-MODEL	DESCRIPTION	LOCATION
1	Datametrics	Time Code Generator	A-7D
1	Power Cube	Power Supply	A-7D
1	AFWAL/FIBG	Power Distribution Box	A-7D
1	Lockheed-Leach	Tape Recorder	A-7D
1		Telemetry Transmitter	A-7D
1		Telemetry Antenna	A-7D
1	Base10, Inc.	PCM Encoder	A-7D
9	AFWAL/FIBG	Amplifier box	A-7D
1	Honeywell 101	Tape Recorder	Van
3	Honeywell 96	Tape Recorder	Van
1	Honeywell 1858	8-Channel Oscillograph	Van
1	EMR 708	PCM decoder	Van
1		Telemetry Receiver	Van
1		Telemetry Antenna	Van
6	Teledyne Taber	Pressure Transducer	See table I
6	Setra 141A	Accelerometers	See table I
6	Micro-Measurements	Strain Gages	See table I
2	Schaevitz 5000HCD	LVDTs	See table I
1		String Potentiometer	See table I
2	On board aircraft	Wheel Proximity Probes	See table I

A.3 TABLE III LOG OF TAPE RECORDS

(Page 1 of 3		December 1984)			
DATE	LEACH TAPE NUMBER	LEACH RECORD NUMBER	LEACH TIME SECONDS	TM RECORD NUMBER	DESCRIPTION
12/1	XX				OVDC
	0	1			1VDC, 2VDC, 3VDC, 4VDC, 5VDC into 0-5VDC Channels
12/2	1	1			OVDC, 1VDC, 2.0VDC, 2.5VDC, -2.5VDC, -2.0VDC -1.0VDC, OVDC into -2.5 to +2.5VDC Channels
		2			OMV, +5MV, -5MV, -8MV, OMV into -10mvdc to +10mvdc Channels
12/6	2	1	40		DP3 12" none
		2	40		DP3 8" repeat
		3	40		DP3 4" line
		4	40		DP3 8" chrome
		5	40		DP3 4" chrome
		6	40		DP3 0" chrome
		7	40		DP2 0" chrome
		8	40		DP2 4" chrome
		9	40		DP2 8" chrome
12/6	3	1	40		DP1 1/4" chrome
		2	30		DP1 4" chrome
		3	40		DP1 8" chrome
		4	30		1st record after struts serviced
		5	40		1st time off jacks
		6	5		Pilot before T.O. at Des Moines
		7	120		30 Seconds before landing at Whiteman
	4	1	45		Cal with nose on jacks-checking SG1
		2	30		+1g 3 point cals on all 6
		3	45		0 g accelerometers simultaneously
		4	45		-1g
		5	45		0 g
		6	45		+1g
12/10	5	1	60		CAL
		2	30		Aircraft resting on gear
		3	60		CAL with aircraft jacked all the way up
		4	30		Plane on jacks-struts serviced
		5	35		Plane on gear- struts serviced
12/11	6	1	50		CAL while on MAT light weight - 24,500
		2	50	1	CAL while on MAT with 6 MK-84 - 2,000 ea
		3	50		CAL while on on MAT-Lightweight(LW)
12/12	7	1	60		CAL
		-	--	2	Airplane on runway TM only
		2	41	3	40 knots (run4.1)
		3	30		CAL

TABLE III LOG OF TAPE RECORDS  
(Page 2 of 3 December 1984)

DATE	LEACH TAPE NUMBER	LEACH RECORD NUMBER	LEACH TIME SECONDS	TM RECORD NUMBER	DESCRIPTION
12/14	8	1	30		CAL
		-	--		Airplane at spalls TM only
		2	48	5	10 knots spall LW (run 4.1)
		3	43	6	10 knots spall LW (run 4.1) repeated
		4	32	7	3 knots spall LW practice
		5	39	8	10 knots spall LW (run 4.1) repeated
		6	44	9	20 knots spall LW (run 4.2)
12/14	9	7	60	10	10 knots spall LW (run 4.1)
		1	30		CAL
		2	48	11	20 knots spall LW (run 4.2)
		3	42	12	27 knots spall LW (run 4.5)
		4	50	13	29 knots spall LW (run 4.3)
12/14	10	5	56	14	39 knots spall LW (run 4.4)
		1	30		CAL
		2	52	15	10 knots spall HW (run 5.1)
		3	15	16	19 knots spall HW (run 5.2)
		4	49	17	29 knots spall HW (run 5.3)
		5	77	18	38 knots spall HW (run 5.4)
12/15	11	6	30		CAL
		1	30		Aircraft on jacks
12/17		2	45		Aircraft off jacks
		3	74	19	44 knots bump LW (run 4.1)
		4	71	20	59 knots bump LW (run 4.2)
12/17	12	5	80	21	82 knots LW (run 4.3)
		6	30		CAL
		1	30		CAL
		2	87	22	92 knots bump LW (run 4.4)
		3	95	23	100 knots bump LW (run 4.5)
		4	98	24	111 knots bump LW (run 4.6)
	13	5	30		CAL
		1	30		CAL
		2	110	25	123 knots bump LW (run 4.7)
		3	58	26	30 knots brake bump LW (run 5.1)
		4	54	27	40 knots brake bump LW (run 5.2)
	14	5	59	28	60 knots brake bump LW (run 5.3)
		6	30		CAL
1		30		CAL	
2		60	29	78 knots brake bump LW (run 5.4)	
3		75	30	94 knots brake bump LW (run 5.5)	
15	4	83	31	100 knots brake bump LW (run 5.6)	
	5	30		CAL	
	1	80		CAL	
	2	74	32	100 knots brake bump LW (run 5.6) repeat	
	3	82	33	110 knots brake bump LW (run 5.7)	
	4	30		CAL	
	5	120		Aircraft on jacks	

TABLE III LOG OF TAPE RECORDS

(Page 3 of 3 December 1984)

DATE	LEACH TAPE NUMBER	LEACH RECORD NUMBER	LEACH TIME SECONDS	TM RECORD NUMBER	DESCRIPTION	
12/18	16	1	30		CAL	
		2	38	34	False start	
		3	60	35	24 knots bump HW (run 4.1)24k actual	
		4	60	36	40 knots bump HW (run 4.2)	
		5	80	37	40 knots bump HW (run 4.2) repeat	
	17	17	6	80	38	62 knots bump HW (run 4.3)
			1	30		CAL
			2	88	39	70 knots bump HW (run 4.4)
			3	81	40	61 knots bump HW (run 5.1)8 deg tail
			4	85	41	69 knots bump HW (run 5.2)8 deg tail
	18	18	5	30		CAL
			1	30		CAL
			2	96	42	81 knots bump HW (run 5.3) 8 deg tail
			3	84	43	59 knots bump HW (run 6.1)5 deg tail
			4	80	44	72 knots bump HW (run 6.2)5 deg tail
19	19	5	30		CAL	
		1	30		CAL	
		2	51	45	20 knots accel bump HW(run7.1)5deg tail	
		3	30		CAL in hagner	
		4	30		Zero check on jacks in hagner	
12/19	20	5	60		CAL	
		1	30		CAL	
		2	60	46	40 knots 2 bumps LW (run 4.1)	
		3	51	47	59 knots 2 bumps LW (run 4.2)	
		4	74	48	72 knots 2 bumps LW (run 4.3)	
	21	21	5	99	49	81 knots 2 bumps LW (run 4.4)
			6	30		CAL
			1	30		CAL
			2	47	50	42 knots brake 2 bumps LW (run 5.1)
			3	55	51	62 knots brake 2 bumps LW (run 5.2)
	22	22	4	70	52	22 knots 2 bumps HW (run 6.1)
			5	60	53	20 knots 2 bumps HW (run 8.0)180psi nose
			6	84	54	60 knots 2 bumps HW (run 8.1)180psi nose
			7	30		CAL
			1	30		CAL
23	23	2	61	55	20 knots 2 bumps HW (run 6.1)nose normal	
		3	20	56	False start	
		4	55	57	39 knots 2 bumps HW (run 6.2)nose normal	
		5	53	58	29 knots 2 bumps HW (run 6.3)nose normal	
		6	150		Last on jacks zero-2 minutes CAL 30 sec	
23	23	1	20		CAL	
		2			Landing at Des Moines, IA	
		3			Landing at Springfield, IL	
		4			Landing at WPAFB, OH 1/6/85	

NOTES:

- LW = Lightweight
- HW = Heavyweight
- CAL = Accelerometer and strain gage cal off 1/2 of record and cal on 1/2 of record
- (run n.n) = AFFTC Run Number n.n

A.4 TABLE IV CALIBRATION TABLE

AS OF DATE: MAY 13, 1985  
 A-7 HAVE BOUNCE PROGRAM JON20545001

ID	UNITS	CALIBRATION EQUATIONS K*C	B	COUNT FOR ZERO LOAD = K/B	ADDITIONAL COMMENTS
P1	PSIG	1.2231C +	2.4229	-1.980921	
P2	PSIG	1.2213C -	55.4263	45.3842	
P3	PSIG	1.2208C -	54.8085	44.8954	
P4	PSIG	1.2217C -	65.787	53.8489	
P5	PSIG	1.2200C -	58.8767	48.2613	
P6	PSIG	1.2190C -	62.8598	51.5674	
P7	PSIG	1.2221C -	51.2398	41.9267	
P8	PSIG	1.2199C -	65.9057	54.0237	
A1	G'S	4.9297E-03C -	10.33892	2097.24	2300.09(1g)*
A2	G'S	5.3662E-03C -	11.0843	2065.41	2251.65(1g)*
A3	G'S	4.3752E-03C -	8.74601	1998.97	2227.53(1g)*
A4	G'S	5.3795E-03C -	10.6236	1974.84	2160.73(1g)*
A5	G'S	5.1732E-03C -	10.4321	2016.57	2209.88(1g)*
A6	G'S	4.5935E-03C -	9.1363	1988.96	2206.66(1g)*
SG1	POUNDS	34.5741C -	70531	2040	TENSION
SG2	POUNDS	35.2732C -	72310	2050	TENSION/COMPRESSION
SG3	POUNDS	59.0751C -	125587	1960	COMPRESSION
SG4	POUNDS	30.9121C		1050/2030**	TENSION
		25.6681C -	52182		COMPRESSION
SG5	POUNDS	50.4072C -	111052	1963	COMPRESSION
SG6	POUNDS	29.5039C		1549/2055**	TENSION
		25.1509C -	51685		COMPRESSION
RP1	KNOTS	0.1584C -	325.565	2055.83	
RP2	KNOTS	0.1580C -	324.077	2051.73	
DP1	INCHES	-5.1592E-03C +	13.5842	2633.01	
DP2	INCHES	2.4954E-03C -	1.6347	655.07	
DP3	INCHES	2.4410E-03C -	1.2596	516.00	

NOTES: \*Recommend compute 1g counts at start of each run.

\*\*Zero change occurred at TM record 31 on 12/17/84

I.E. LW over mats at 94 knots.

Calibrations are derived from Least Squares Best Fit Straight Line.

K(engineering units/count) B(engineering units)

C = Counts

A.5 TABLE V LEACH TAPE TRACK ASSIGNMENTS

TRACK NUMBER	DATA DESCRIPTION
1	RPM1-ANALOG FM
2	RPM2-ANALOG FM
3	TIME CODE(IRIG B)-ANALOG FM
4	VOICE
7	PCM(DMM)-DR
9	PCM(BI-Ø-L)-DR

TAPE SPEED: 60 inches per second

A.6 TABLE VI A7-D HAVE BOUNCE PCM FORMAT

(C) DB 25 OCT 1984 AFWAL/FIBG

12 BITS PER WORD-NO PARITY(12BNP)

	<u>12BNP</u>				<u>11B+P</u>
SYNC1	4015	1111	1010	1111	2007
SYNC2	1844	0111	0011	0100	922

MAJOR FRAME FORMAT

SY1	S2Y	FID	SG3	SG4	SG5	SG6	RP1	RP2	SG1	A1	DP1	A3	P1	P5	TC
SY1	SY2	FID	SG3	SG4	SG5	SG6	RP1	RP2	SG2	A2	DP2	A4	P2	P6	DD
SY1	SY2	FID	SG3	SG4	SG5	SG6	RP1	RP2	SG1	A1	DP3	A5	P3	P7	TC
SY1	SY2	FID	SG3	SG4	SG5	SG6	RP1	RP2	SG2	A2	DP4	A6	P4	P8	DD

SYMBOLS:

SG =Strain Gage  
 SY =Sync Word  
 FID=Frame I.D.  
 RP =Revolutions Per Minute  
 P =Pressure  
 DP =Displacement  
 TC =Time Code  
 DD =Discrete  
 A =Accelerometer

NOTES:

Bit Rate = 150 Kbps  
 4 minor Frames/Major Frame  
 $150 \text{ b/s}/12 \text{ b/wd} = 12,500 \text{ wd/sec}$   
 $12,500 \text{ wd/sec} / 16 \text{ wd/mF} = 781.25 \text{ mF/sec}$   
 $781.25 \text{ mF/sec}/4 \text{ mF/MF} = 195.3125 \text{ MF/sec}$   
 mF = minor frame      MF = Major Frame  
 b = bits      wd = words      sec = seconds

<u>CHANNEL TYPE</u>	<u>Base 10 Input Range</u>
Accelerometer	-2.5 to +2.5 VDC
Strain Gage	-10 to +10 mvDC
RP1 and RP2	-2.5 to +2.5 VDC
Pressure	0 to +5 VDC
DP1	0 to +5 VDC
DP2 and DP3	-2.5 to +2.5 VDC

#### A.7 TABLE VII A-7D AIRCRAFT TEST CONFIGURATIONS

Aircraft Flap Setting	Ordinance	Amunition	Fuel Wt	GW
Take-Off 1/2	6 MK-84 (1 per wing station) 2 AIM-9E(fuselage stations)	1000 rounds 20 mm target practice	6350	26.19% 42,000
Landing Full	Pylons only	1000 rounds 20 mm target	1800	26.14% 24,520

All ordinance are inert and jettisonable

#### A.8 TABLE VIII LANDING GEAR LOAD LIMITS

<u>Member</u>	<u>Allowable Load, Lbs</u>
Nose Landing Gear	
Knee Link	+144,660 Axial Tension
Drag Strut	-77,150 Axial Compression
Tire Bottoming Load	18,000 lbs @ 100 psig 27,700 lbs @ 185 psig
Main Landing Gear	
Shock Strut	-150,000 Axial
Drag Strut	-58,000 Axial Compression +59,330 Axial Tension
Tire Bottoming Load	44,1000 lbs

NOTE: Test allowable load limits are defined as the loads corresponding to 90 percent of the design limit loads.

A.9 TABLE IX A-7D HAVE BOUNCE TEST RUNS

Run Number	AC Cond.	Bump	Fuel Wt(lbs)	Net Wt(lbs)	Target Vel(Kts)	Actual Vel(Kts)	Date	Notes
1	L	1-3	----	24500	40	44	12	
2	L	Spall	----	24500	10	12	14	
3	L	Spall	----	24500	10	9	14	
4	L	Spall	----	24500	4	3	14	
5	L	Spall	----	24500	10	9	14	
6	L	Spall	----	24500	15	17	14	
7	L	Spall	1700	24420	10	10	14	
8	L	Spall	2500	25220	20	18	14	
9	L	Spall	2350	25070	30	28	14	
10	L	Spall	2100	24820	30	29	14	
11	L	Spall	1800	24520	40	38	14	
12	T.O.	Spall	7250	42900	10	10	14	
13	T.O.	Spall	7000	42650	20	19	14	
14	T.O.	Spall	6800	42450	30	29	14	
15	T.O.	Spall	6450	42100	40	39	14	
16	L	1-3	2550	25270	40	44	17	
17	L	1-3	2400	25120	60	57	17	
18	L	1-3	2100	24820	80	76	17	
19	L	1-3	1800	24520	90	88	17	
20	L	1-3	2600	25320	100	99	17	
21	L	1-3	2100	24820	110	110	17	
22	L	1-3	1600	24320	120	121	17	
23	L	1-3	2600	25320	20	20	17	Light Braking
24	L	1-3	2400	25120	30	25	17	Light Braking
25	L	1-3	2100	24820	60	55	17	Light Braking
26	L	1-3	2600	25320	70	70	17	Light Braking
27	L	1-3	2250	24970	80	85	17	Light Braking
28	L	1-3	1900	24620	90	85	17	Light Braking
29	L	1-3	2500	25220	100	95	17	Light Braking
30	L	1-3	1800	24520	100	100	17	Light Braking
31	T.O.	1-3	7000	42650	20	24	18	
32	T.O.	1-3	6200	41850	40	40	18	
33	T.O.	1-3	5000	40650	40	40	18	
34	T.O.	1-3	4800	40450	60	61	18	
35	T.O.	1-3	7300	42950	70	70	18	
36	T.O.	1-3	7100	42750	60	61	18	8 deg Stab.
37	T.O.	1-3	6200	41850	70	69	18	8 deg Stab.
38	T.O.	1-3	5900	41550	80	81	18	8 deg Stab.
39	T.O.	1-3	7200	42850	60	59	18	185psi NoseTires
40	T.O.	1-3	6900	42550	70	72	18	185psi NoseTires
41	T.O.	1-3	6200	41850	20	20	18	Accelerating
42	L	2-3	2600	25320	40	40	19	
43	L	2-3	2400	25120	60	58	19	
44	L	2-3	2100	24820	70	72	19	
45	L	2-3	1800	24520	80	80	19	
46	L	2-3	1500	24220	40	40	19	Light Braking
47	L	2-3	2400	25120	60	60	19	Light Braking
48	T.O.	2-3	7500	43150	20	22	19	
49	T.O.	2-3	6600	42250	40	41	19	185psi NoseTires
50	T.O.	2-3	6200	41850	60	61	19	185psi NoseTires
51	T.O.	2-3	5600	41250	20	20	19	
52	T.O.	2-3	5400	41050	40	39	19	
53	T.O.	2-3	5000	40650	30	29	19	

A.10 TABLE X EQUATIONS FOR DERIVED QUANTITIES

- |   |                              |
|---|------------------------------|
| 1. NLG shock strut load from knee link load:                | $-F_{SK}^{*}(SG\ 1)$         |
| 2. NLG shock strut load from lower pressure:                | $-17.646*(P\ 2)$             |
| 3. NLG vertical tire load from knee link load:              | $F_{AK}^{*}(SG\ 1)$          |
| 4. Left MLG shock strut load from lower pressure:           | $-11.027*(P\ 4)$             |
| 5. Left MLG vertical wheel load from shock strut load:      | $-F_{MN}^{*}(DP\ 2)*(SG\ 3)$ |
| 6. Right MLG shock strut load from lower pressure:          | $-11.027*(P\ 7)$             |
| 7. Right MLG vertical wheel load from shock strut load:     | $-F_{MN}^{*}(DP\ 3)*(SG\ 5)$ |
| 8. Average MLG vertical wheel load from left & right above: | $((5) + (7))/2$              |

where for nose landing gear: S = output from DP 1

$$T_1 = (16.21 - S)^2 \quad T_2 = \text{sqrt}(18.49 + T_1)$$

$$\theta_1 = \cos^{-1}((T_1 - 31.5911)/(14.30*T_2))$$

$$\theta_2 = \cos^{-1}((T_1 + 68.5711)/(20.12*T_2))$$

$$\theta_3 = \theta_1 + \cos^{-1}(4.3/T_2) \quad \theta_4 = \theta_2 + \sin^{-1}(4.3/T_2)$$

$$\theta_5 = \theta_1 + \theta_2 \quad F_{AK} = 10.06*\sin\theta_5/(14.5*\sin\theta_4)$$

and  $F_{SK} = F_{AK} + \sin\theta_3$

and for main landing gear: S = output from (I)

$$T_1 = 44.10 - S \quad \theta_1 = \cos^{-1}((2374.77 - T_1^2)/1942.03)$$

$$\theta_2 = \cos^{-1}((1366.76 + T_1^2)/(86.50*T_1))$$

$$F_{MN}^{*}(I) = \sin\theta_2/(1.21827*\cos(\theta_1 - 34.86)) - .003$$

## A.11 TABLE XI PLOT FORMATS

### Page 1:

1. Nose gear vertical tire load from knee link load. (NG V)\*
2. Average main gear vertical tire load from left and right. (AM V)
3. Normal acceleration at aircraft CG. (A 1)
4. Normal acceleration at pilots seat. (A 2)

### Page 2:

1. Nose gear shock strut load from knee link load and lower pressure. (NS S)
2. Left main gear vertical tire load from shock strut load. (LM V)
3. Right main gear vertical tire load from shock strut load. (RM V)
4. Main gear wheel velocity left and right. (RPM)

### Page 3:

1. Left main gear shock strut stroke. (DP 2)
2. Left main gear shock strut load and shock strut load from lower pressure. (LM S)
3. Left main gear drag strut load. (SG 4)
4. Left main gear shock strut upper and lower pressures. (P3 and P4)

### Page 4:

1. Right main gear shock strut stroke. (DP 3)
2. Right main gear shock strut load and shock strut load from lower pressure. (RM S)
3. Right main gear drag strut load. (SG 6)
4. Right main gear shock strut upper and lower pressures. (P6 and P7)

### Page 5:

1. Nose gear shock strut stroke. (DP 1)
2. Nose gear knee link load. (SG 1)
3. Nose gear drag strut load. (SG 2)
4. Nose gear shock strut upper and lower pressures. (P1 and P2)

### Page 6:

1. Normal acceleration at center pylon and wing fold. (A6 and A4)
2. Normal acceleration at mid outer panel. (A5)
3. Normal acceleration at wing tip. (A 3)
4. Main gear brake pressures left and right. (P8 and P5)

\* The titles within parentheses correspond to the labels on vertical axes of plots. In plots which overlay two sets of data, the second set is denoted with asterisks.

A.12 TABLE XII MAXIMUM AND MEAN VERTICAL LOADS FOR NOSE AND MAIN GEAR

Run Number	NGV Max	NGV Mean	AMV Max	AMV Mean	LMV Max	LMV Mean	RMV Max	RMV Mean
1	9847	4958	12530	10070	12060	9280	13150	10860
2	8605	4865	12000	10930	11930	10460	13790	11400
3	7670	4833	11690	10850	11370	10350	12670	11350
4	5638	4557	12490	11070	11340	10630	13870	11510
5	7885	4694	11700	10880	11320	10390	12650	11370
6	8763	4969	11470	10460	11430	9932	12990	10990
7	8444	4931	11558	10620	11210	10190	12440	11060
8	8886	5139	12060	10790	11880	10370	13600	11200
9	10120	4756	12900	10640	11670	10270	12000	11020
10	10890	4909	11440	10540	11120	10110	12640	10970
11	11670	4910	11130	10350	10830	9939	12190	10760
12	12400	7943	20910	17030	20810	16640	22400	17410
13	11890	7974	20520	16780	21880	16250	21900	17300
14	11640	7807	20630	16700	20890	16240	23130	17150
15	14770	7860	21200	16500	20820	16060	22460	16940
16	10140	4756	13490	10730	12880	9979	14530	11470
17	12210	4749	12670	10240	11720	9408	13830	11060
18	14200	4472	11500	9703	9683	8956	13720	10450
19	14990	4372	10830	9260	10300	8929	11890	9591
20	16400	3873	10000	8685	9900	8330	11000	9041
21	16730	3441	9650	7809	9040	7568	10570	8049
22	15330	2791	10640	15860	9642	7324	11630	7848
23	9349	5677	12690	10250	11730	9354	13710	11140
24	12010	6204	11710	9945	10790	9242	12690	10650
25	14550	5729	10820	9674	10210	8925	11820	10420
26	16190	5794	10440	9304	10070	8795	11250	9813
27	15600	5186	9800	8572	8800	8140	11000	9005
28	17640	4914	9634	8766	9565	8434	10140	9098
29	14100	3805	9558	8301	8998	7939	10790	8663
30	19770	4302	9451	8333	9303	8085	9975	8581
31	13570	7885	24410	16860	25080	16780	23740	16940
32	16370	7743	24580	16380	2565	16340	23540	16430
33	16080	7957	24110	15900	25250	15840	23050	15960
34	18820	7619	23840	15580	26010	15830	21680	15330
35	20810	7730	25680	16160	27430	16580	23930	15740
36	19450	7668	25890	16430	27800	16720	23970	16140
37	20550	7399	25010	15970	26640	16460	23450	15470
38	22420	7128	24410	15670	27020	16560	21800	14780
39	20150	7866	25780	16440	27950	16640	23610	16240
40	22700	7549	25290	16050	26710	16220	23870	15880
41	15970	82860	24780	16170	25300	15880	24430	16460
42	9133	4371	13000	10660	12900	10000	12900	11310
43	11860	4713	12330	10020	12080	9495	13050	10540
44	13240	4466	11220	9474	10670	8946	12250	10000
45	14180	4312	10720	9077	9725	8554	11790	9601
46	12270	5816	11920	9879	11050	9249	12940	10510
47	15690	6559	11110	9648	10990	9218	11690	10080
48	13680	8074	24700	16920	24220	16310	25250	17530
49	17120	7618	25140	16470	25580	15840	24700	17110
50	22360	77170	25090	16100	25700	15350	24510	16860
51	13790	7811	24030	16380	23840	15780	24230	16980
52	16300	7651	24210	16100	24800	15550	24940	16660
53	15710	7784	24150	16130	24270	15550	24280	16710

APPENDIX B

FIGURES

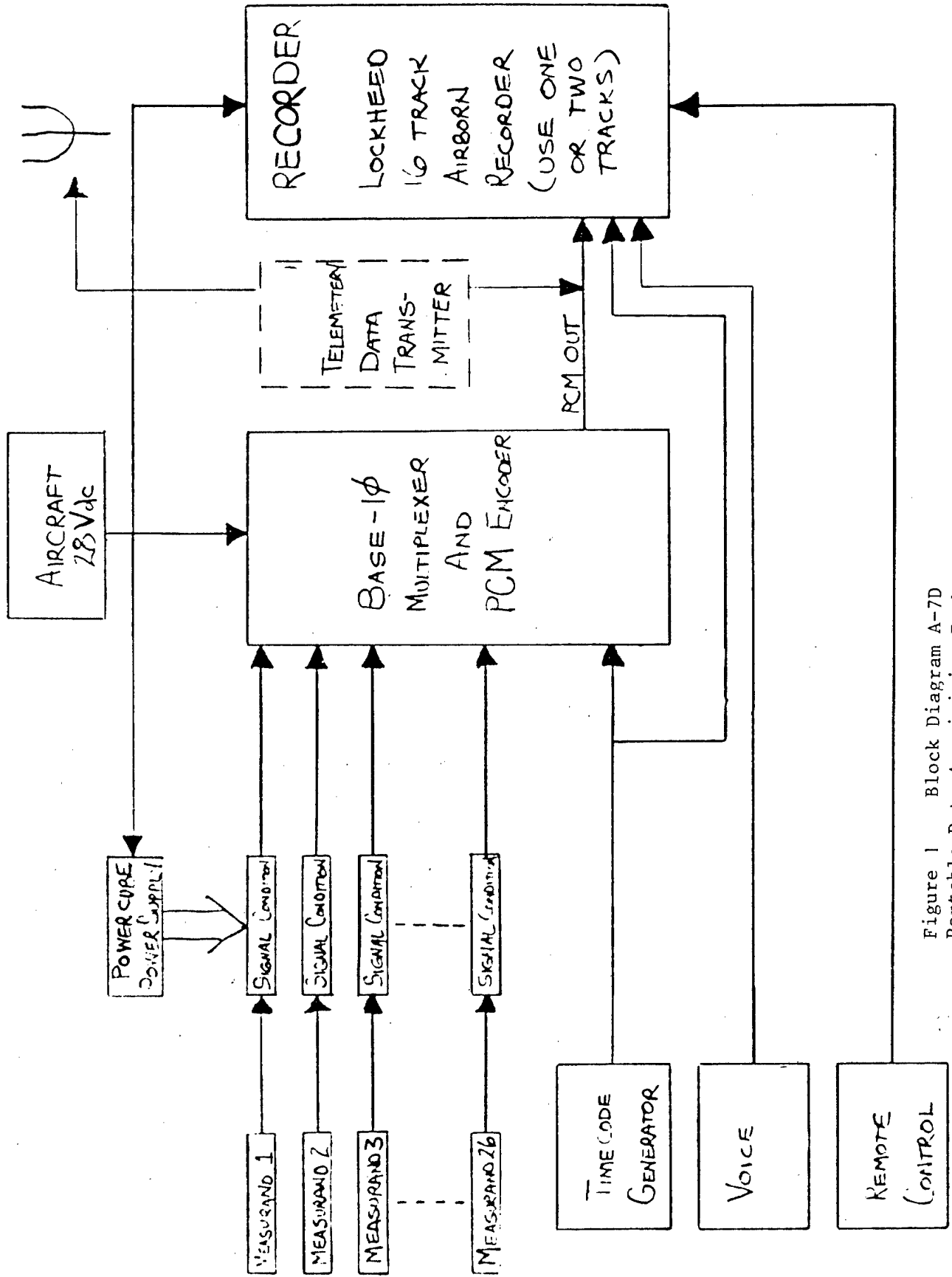

Figure 1 Block Diagram A-7D  
Portable Data Acquisition Package

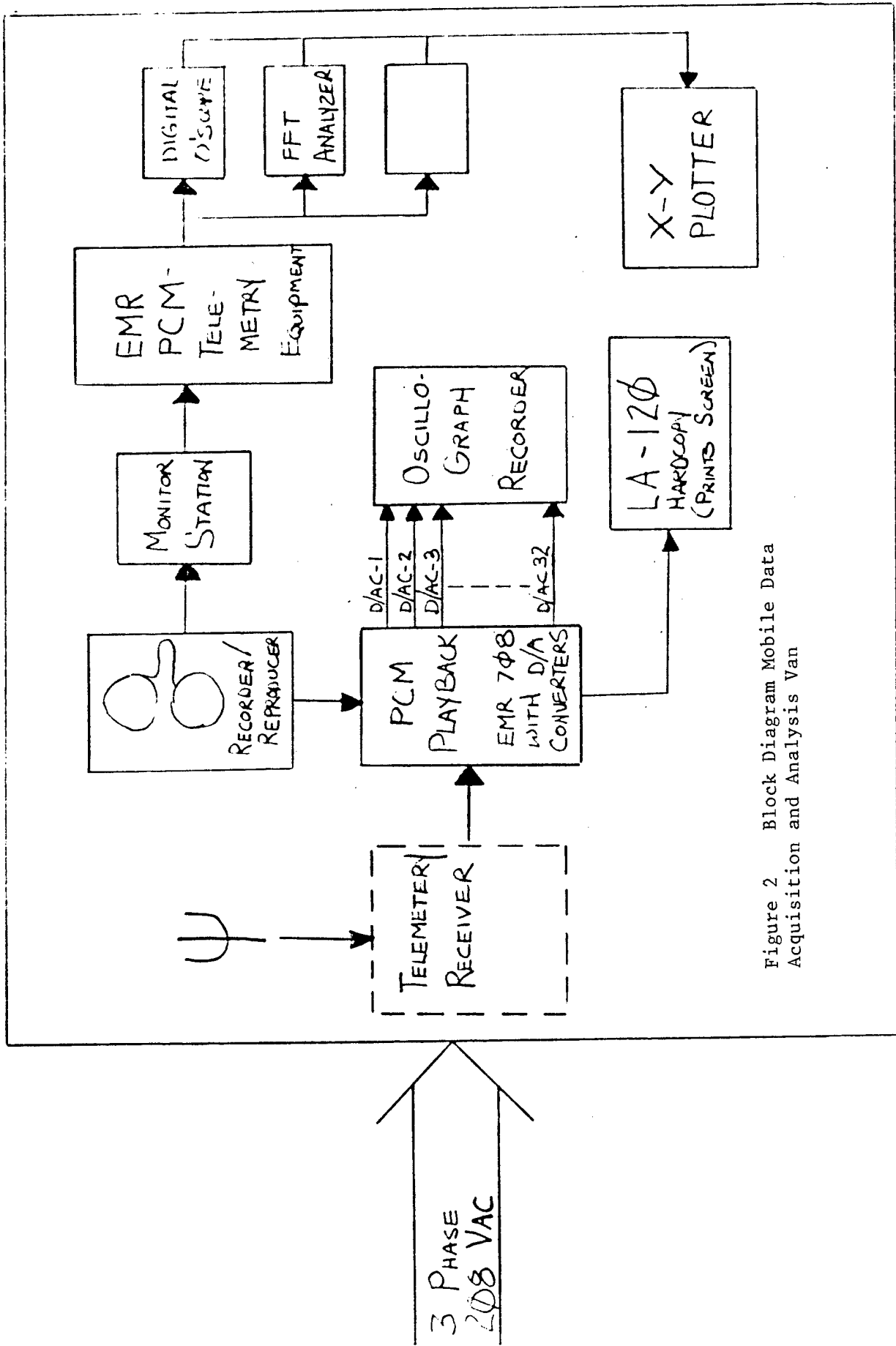

Figure 2 Block Diagram Mobile Data Acquisition and Analysis Van

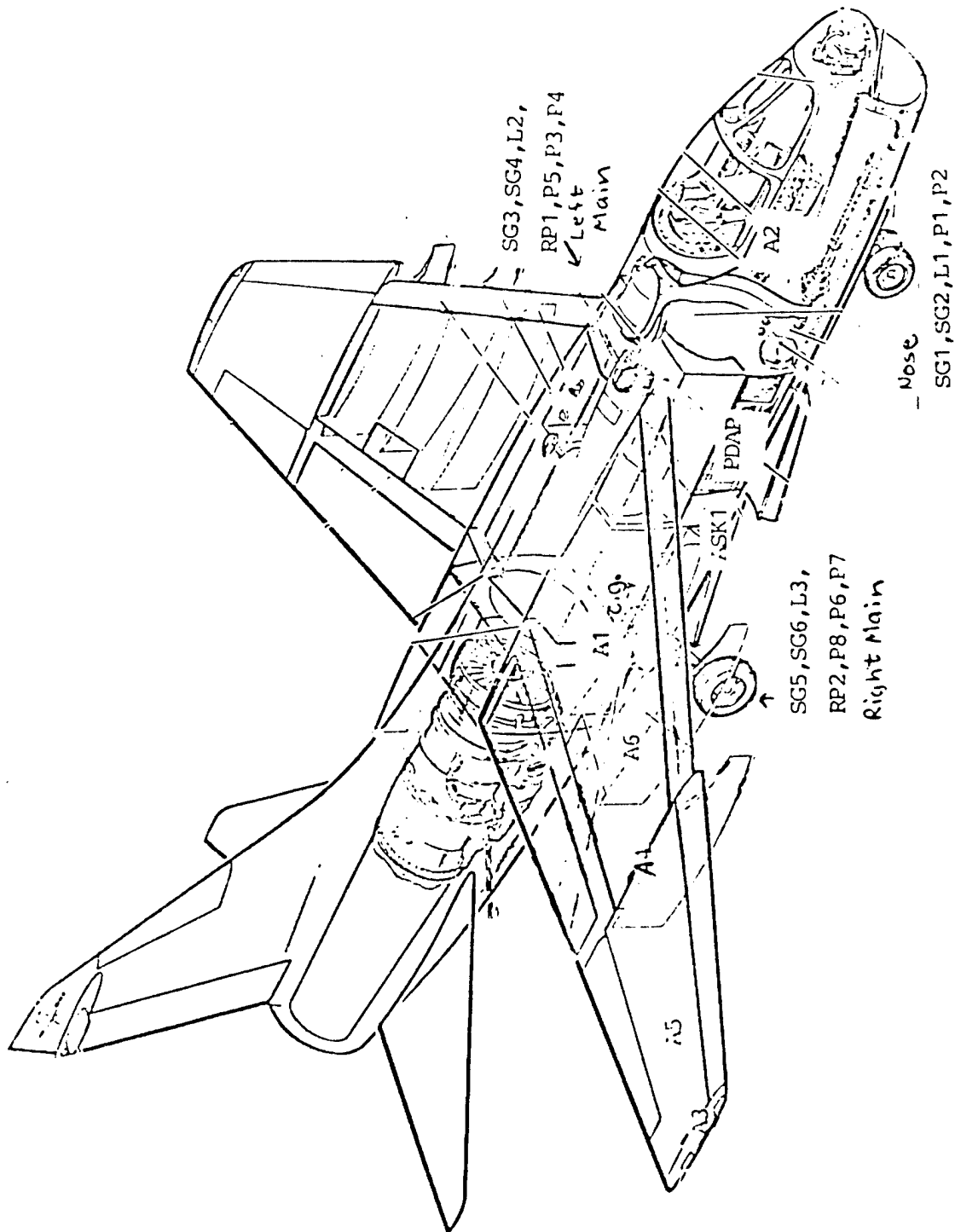

Figure 3 Instrumentation Locations on the A-7D

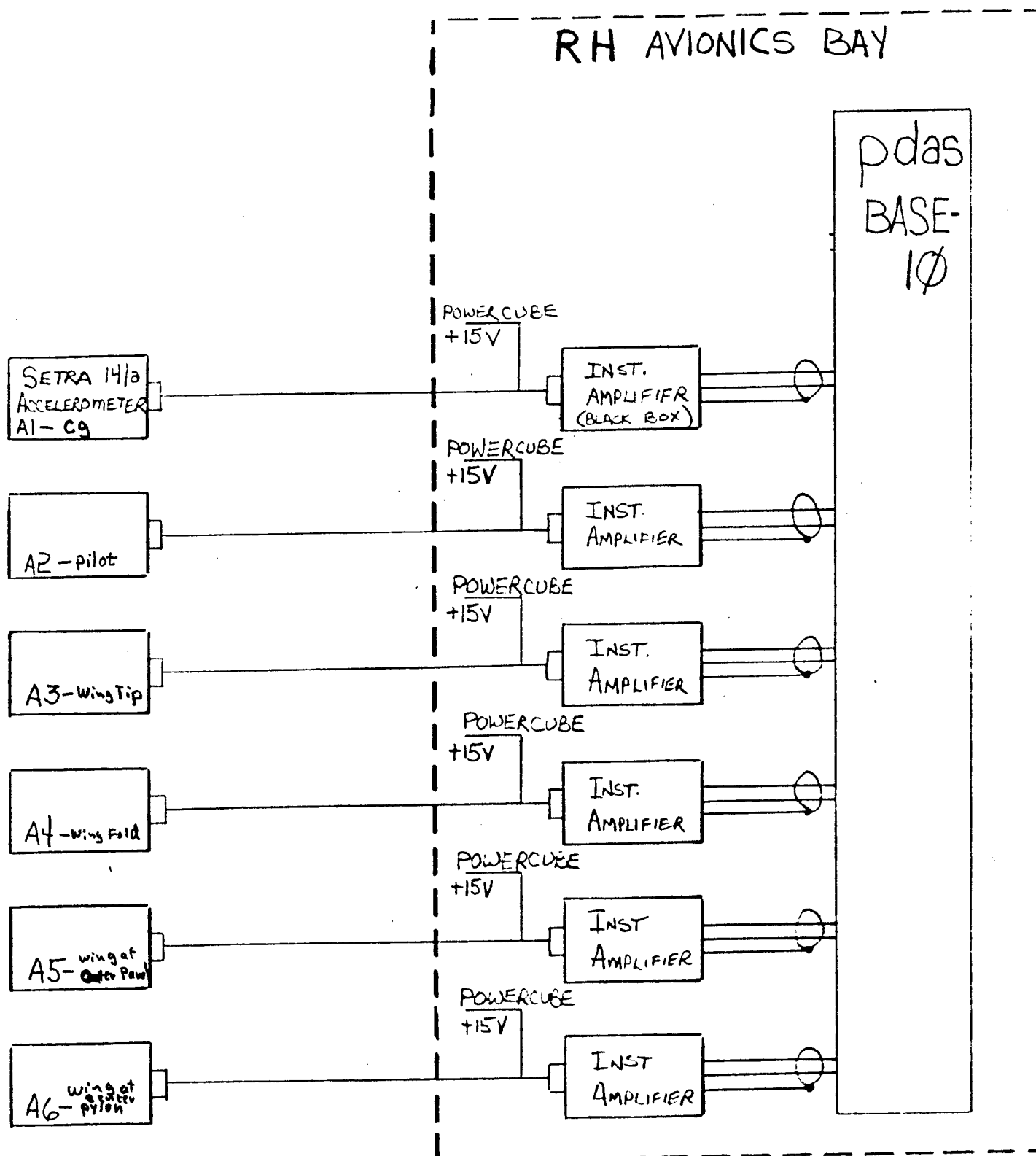

Figure 4 Wiring from Accelerometers to Signal Conditioning

MFB  
10/29/04

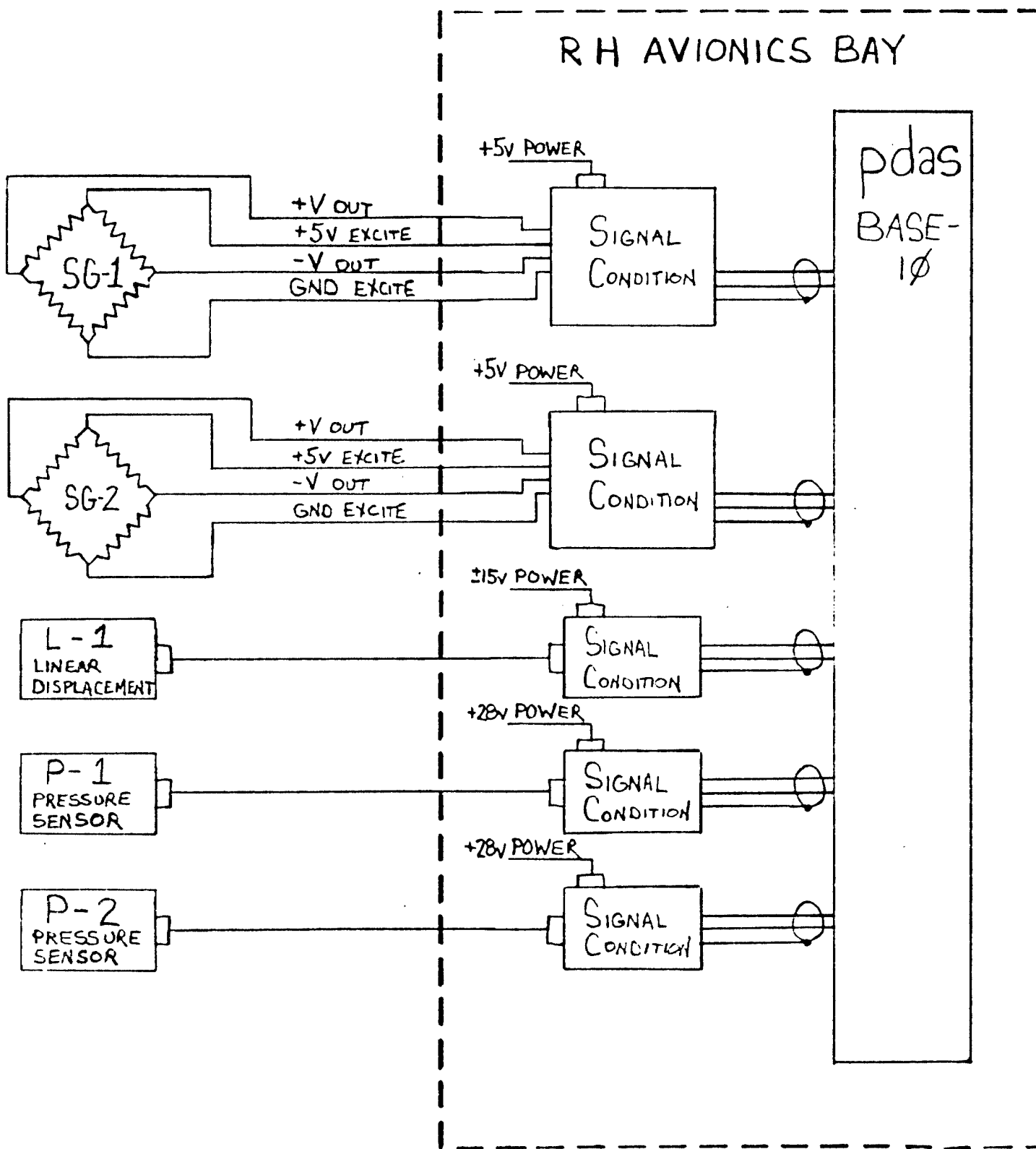

Figure 5 Wiring from Nose Landing Gear to Signal Conditioning

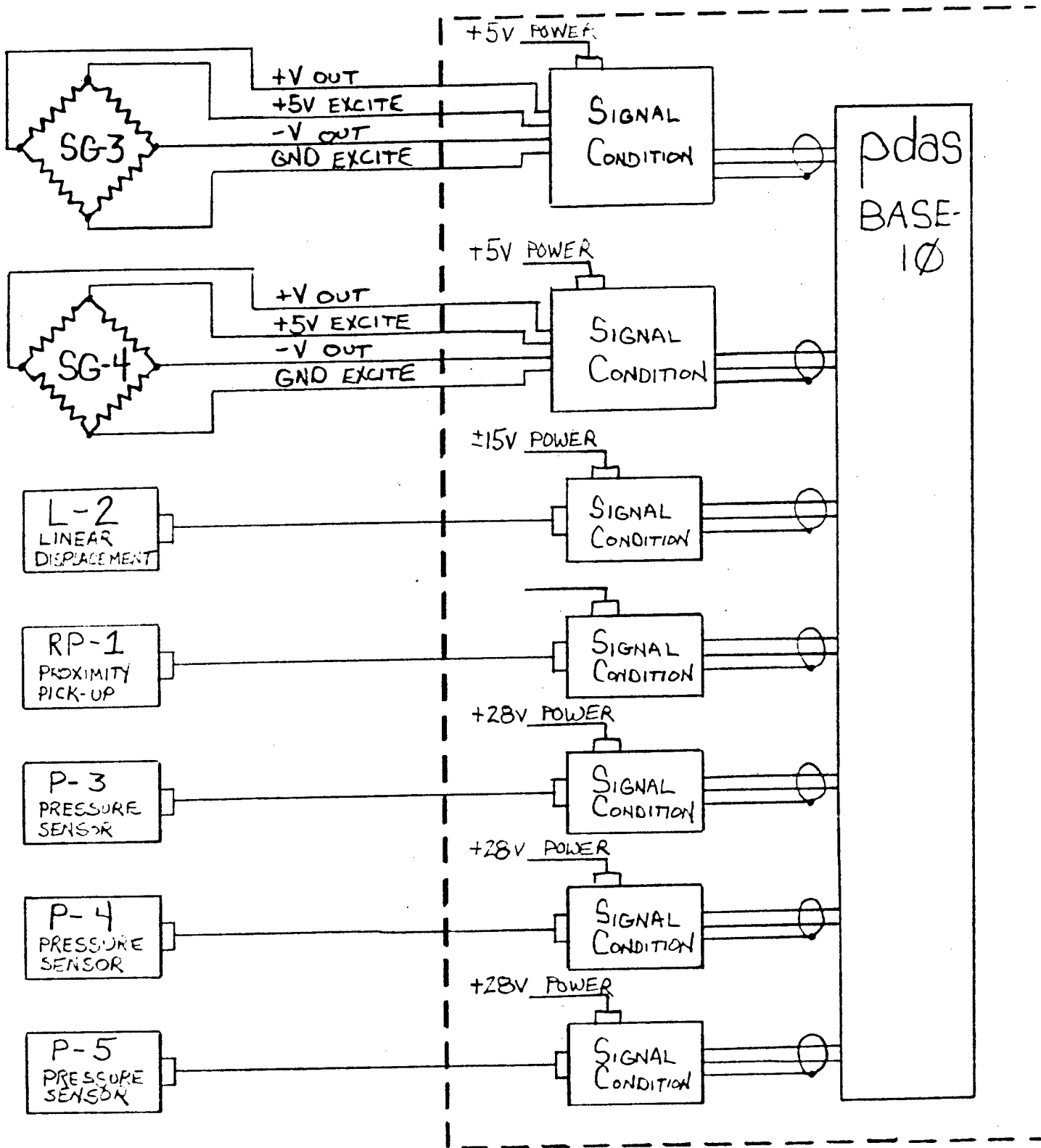

Figure 6 Wiring from Left Landing Gear to Signal Conditioning

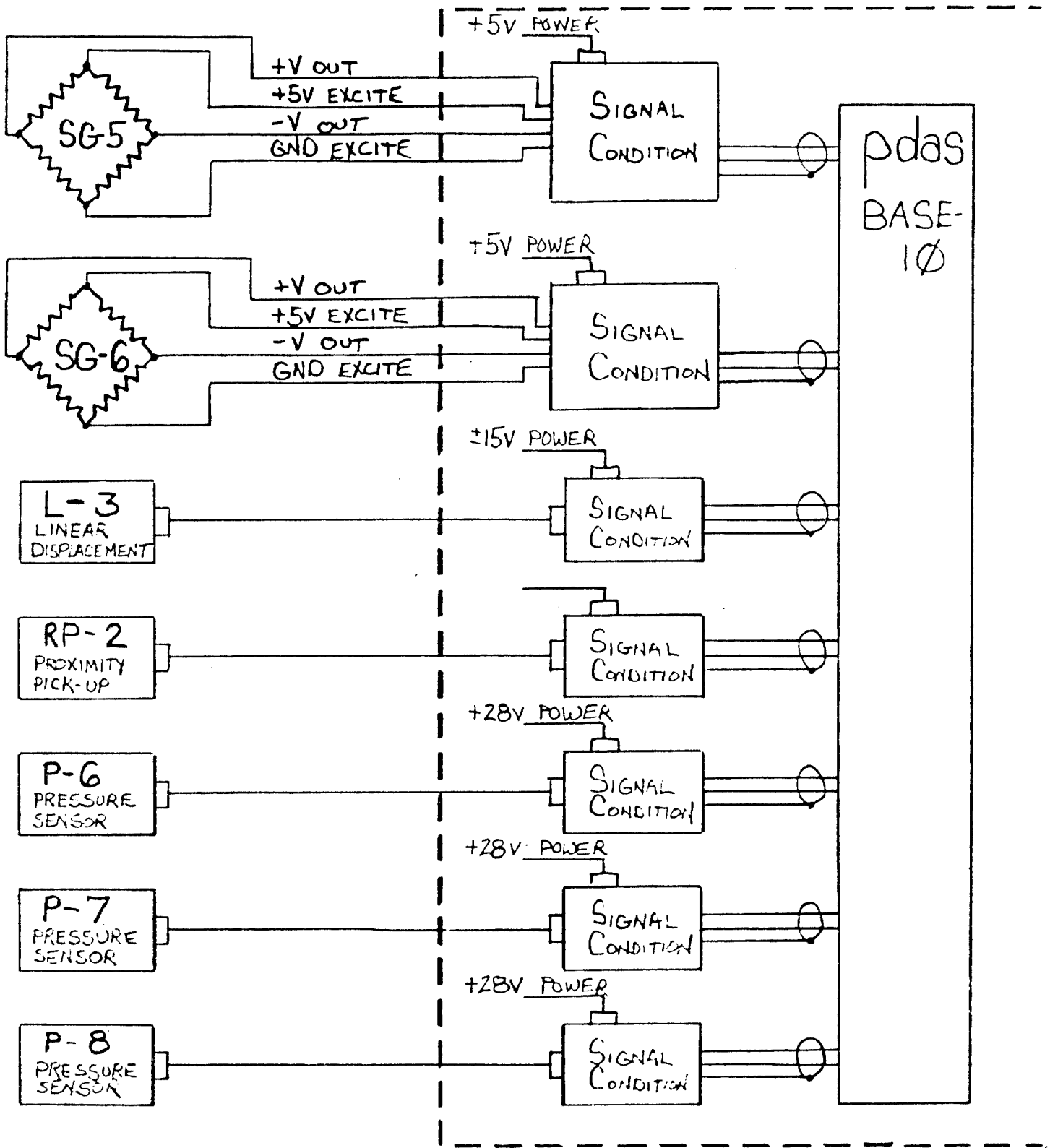

Figure 7 Wiring from Right Landing Gear to Signal Conditioning

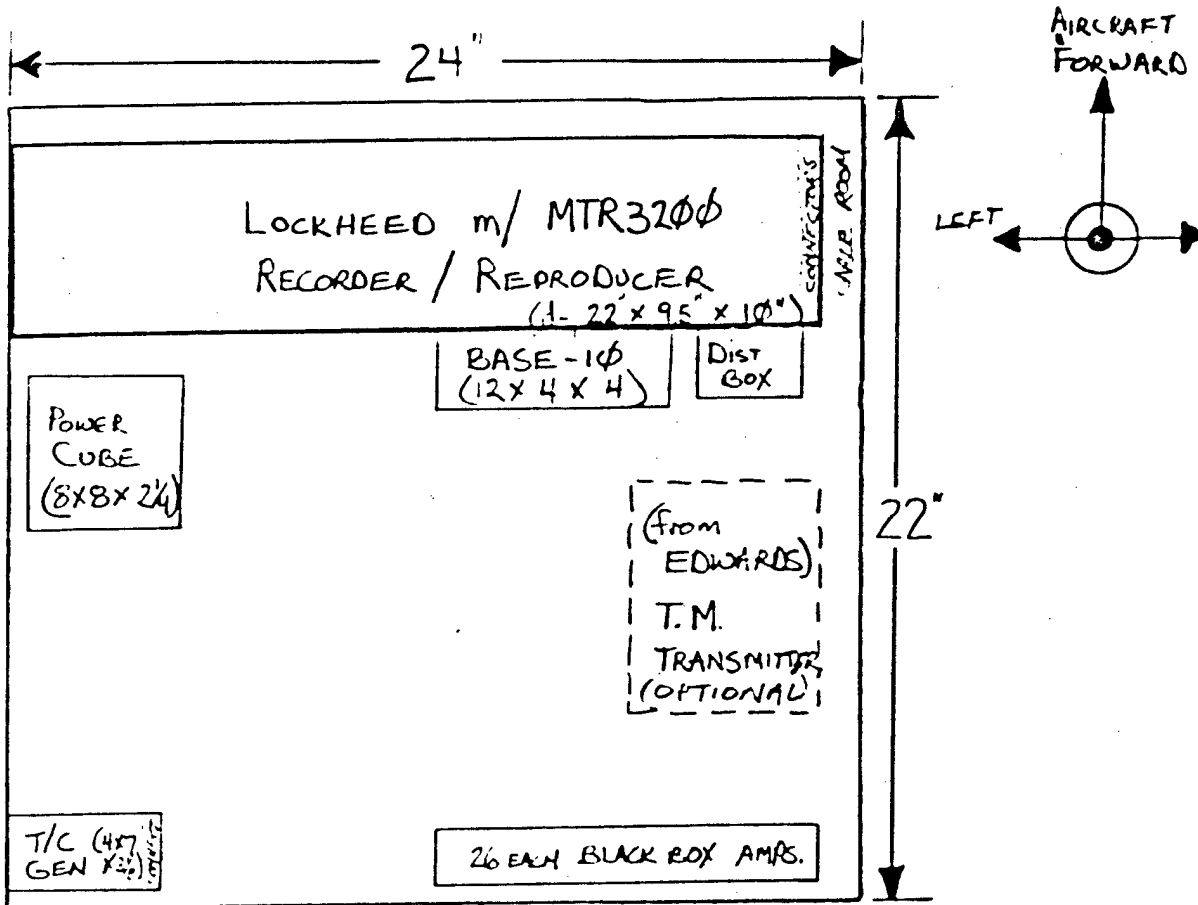

Figure 8 Signal Conditioning in Right Hand Avionics Bay



APPLICATION			REVISIONS		
NEXT ASSY	USED ON	LTR	DESCRIPTION	DATE	APPROVED
			<p>           DATAMETRICS            TIME CODE            GENERATOR            IRIQ B         </p>		
			TOP VIEW		
<p>           J1 = INPUT POWER            J2 = OUTPUT 1PPS            J3 = OUTPUT CODE (IRIQ B)         </p>					
			<p>FRONT VIEW</p>		

UNLESS OTHERWISE SPECIFIED DIMENSIONS ARE IN INCHES TOLERANCES ON FRACTIONS DECIMALS ANGLES $\pm$ $\frac{XX}{100}$ $\pm$ $\pm$ $\frac{XXX}{1000}$	DRAFTSMAN	DATE	U.S. AIR FORCE		
	CHECKER		AFFDL/FBG WPAFB, OHIO 45433		
MATERIAL OVERALL SIZE: $3\frac{1}{8}'' \times 6\frac{13}{16}'' \times 3\frac{3}{16}''$ WEIGHT: 2lb 6oz POWER: 28VDC, .150 AMPS	ENGINEER	12 MAY	TITLE DATAMETRICS TIME CODE GENERATOR		
	A.F. PROJ ENGR	76	MECHANICAL DRAWING WU 14720108		
	CONTRACT NO.		IMPROVED DYNAMIC DATA ACQUISITION PACKAGE		
	A.F. DESIGN ACTIVITY AUTHENTICATOR		SIZE	A.F. CODE IDENT NO.	DRAWING NO.
		A		76A0503	
		SCALE 1" = 2"		SHEET	

AF FORM 1652 SEP 65 PREVIOUS EDITIONS OF THIS FORM ARE OBSOLETE  
 ENGINEERING DRAWING LAYOUT A VERTICAL  
 Figure 9 Datametrics Time Code Generator

APPLICATION			REVISIONS			
NXT ASSY	USED ON	LTR	DESCRIPTION	DATE	APPROVED	

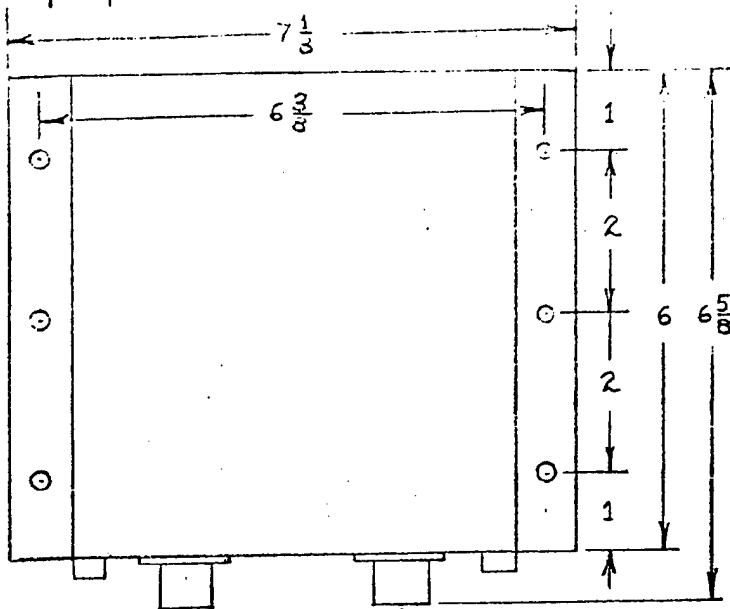

TOP VIEW

J1 = INPUT POWER (+23VDC)  
 J2 = OUTPUT POWER (±15VDC & +5VDC)

POWER TABLE

MASTER AMPLIFIER BOX	SECONDARY AMPLIFIER BOX	NUMBER OF AMPLIFIERS	POWER 28V	
			OLD AMPS	NEW AMPS
1	1	12	1.8A	1.5A
1	3	24	3.3A	2.7A

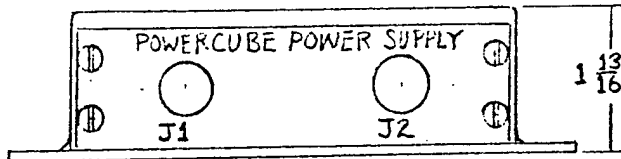

FRONT VIEW

UNLESS OTHERWISE SPECIFIED DIMENSIONS ARE IN INCHES TOLERANCES ON FRACTIONS DECIMALS ANGLES ± .XX± ± XXX±	DRAFTSMAN	DATE	U.S. AIR FORCE		
	CHECKER		AFFDL/FBG WPAFB, OHIO 45433		
MATERIAL OVERALL SIZE: 1 13/16" x 6 5/8" x 7 1/8" WEIGHT: 3lb 1oz POWER: SEE TABLE	ENGINEER D.E. SEELY	12MAR	TITLE POWERCUBE POWER SUPPLY BOX		
	A.F. PROJ ENGR.	1976	MECHANICAL DRAWING, WU 14720108		
	CONTRACT NO.		IMPROVED DYNAMIC DATA ACQUISITION PACKAGE		
	A.F. DESIGN ACTIVITY, AUTHENTICATOR		SIZE A	A.F. CODE IDENT NO.	DRAWING NO. 76A0504
			SCALE 1" = 2"		SHEET

AF FORM 1652 SEP 65 PREVIOUS EDITIONS ARE OBSOLETE Figure 10 Power Cube Power Supply Box AWING LAYOUT A VERTICAL

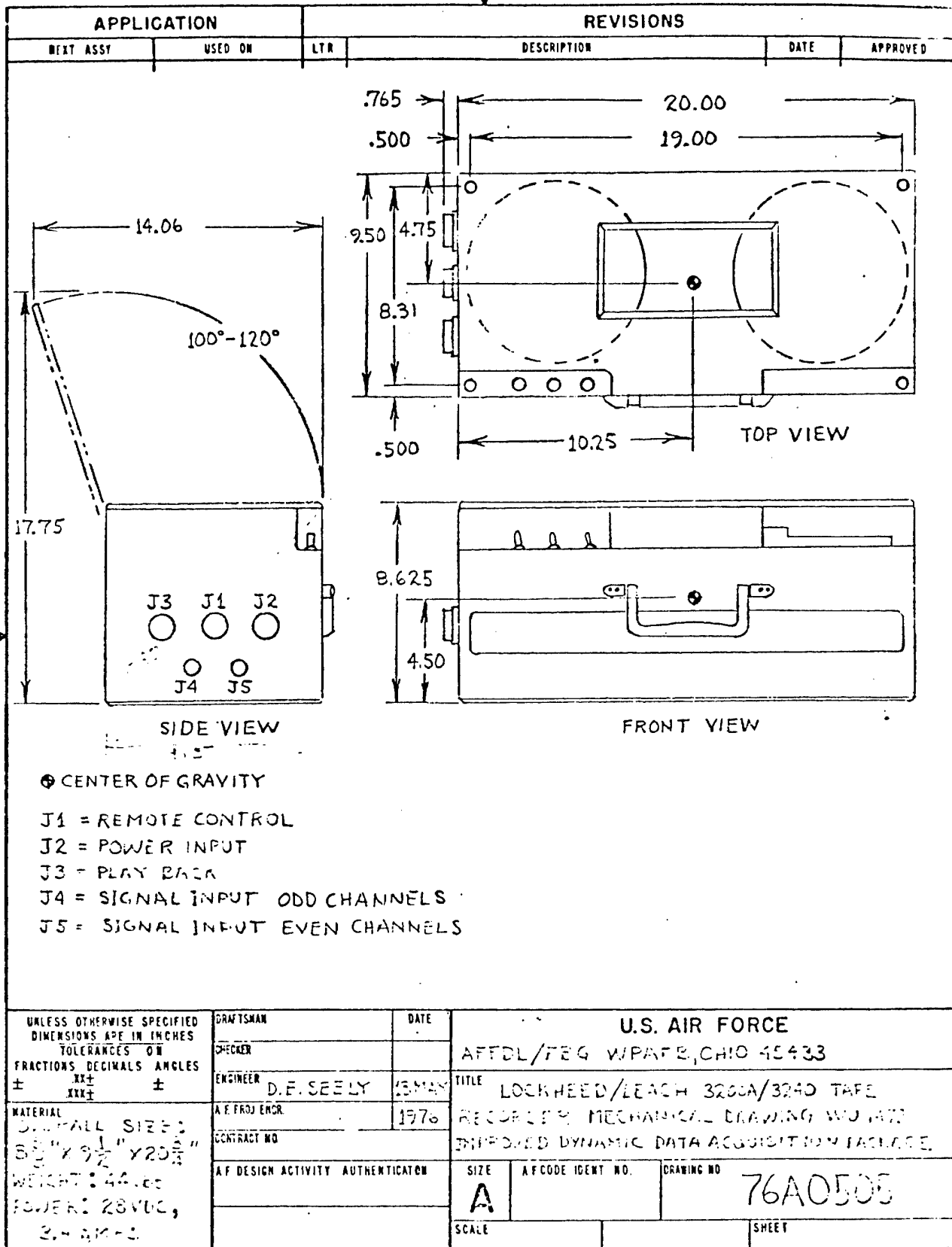

AF 1652 Figure 11 Lockheed/Leach Tape Recorder AWING LAYOUT A VERTICAL

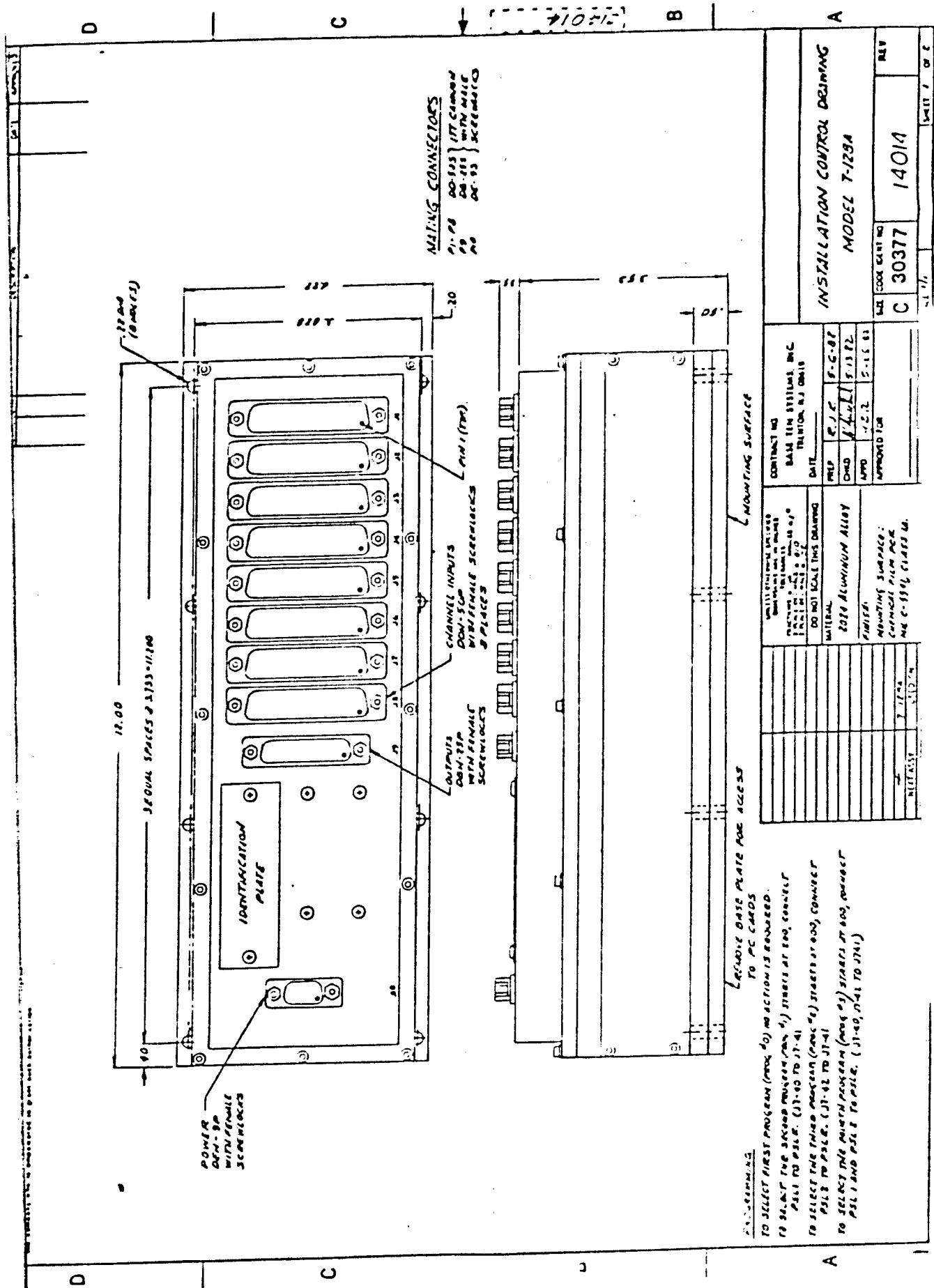
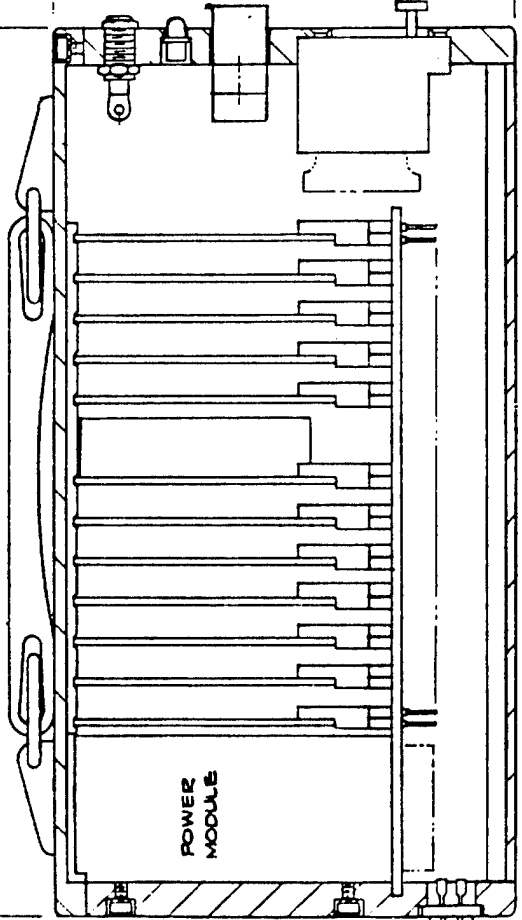

FIGURE 12 MODEL 7-128A PROGRAMMABLE DATA ACQUISITION SYSTEM

B-6816

REVISIONS		DATE	APPROVED
ZONE	LTR	DESCRIPTION	
	C	REDRAWN	9-29-75
	D	TEST POINT SYMBOLS CHANGED TO FUNCTIONAL DESCRIPTIONS	9-30-75
	E	ADDED CONNECTOR CHART	10-7-75
	F	METRIC DIMENSIONS ADDED	12-23-75

7.75 MAX  
(196.85)



4.30 NOM  
(109.22)

4.30 NOM  
(107.6)

CONNECTOR J1  
CANNON DBH-25P W/FEMALE SCREWLOCKS  
MATING CONNECTOR  
CANNON DB-25S W/ MALE SCREWLOCKS

OPTIONAL MOUNTING FLANGE

J1 PIN#	FUNCTION	PIN#	FUNCTION
1	N.C. (RESERVED)	14	N.C. (RESERVED)
2	N.C. (RESERVED)	15	SIGNAL GROUND
3	MAJOR FRAME SYNC	16	+28 VDC
4	WORD SYNC	17	28 VDC RETURN
5	CASE GROUND	18	SPARE
6	SPARE	19	
7	N.C. (RESERVED)	20	
8	N.C.	21	
9	NRZ-L PCM	22	
10	SIGNAL GROUND	23	
11	FRAME SYNC	24	
12	BIT SYNC	25	
13	N.C. (RESERVED)		

NOTE: 1. METRIC DIMENSIONS ARE IN PARENTHESES.

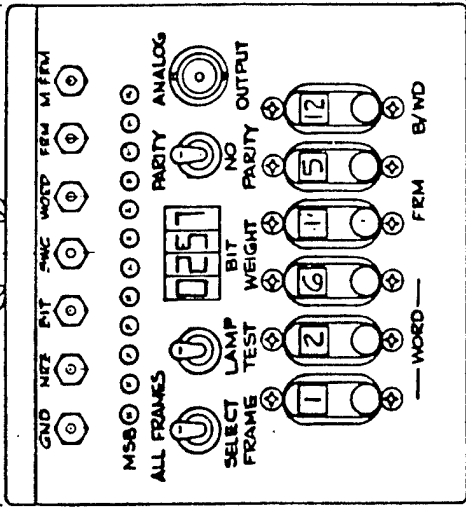

SIGNATURES	DATE	BASE TEN SYSTEMS, INC.	
DRAWN	8/7/75	CONFIGURATION	
CHKD	8/20/75	AIRBORNE ENCODER TEST UNIT	
ENGR.	11/7/75	MODEL 900-920	
UNLESS OTHERWISE SPECIFIED DIMENSIONS ARE IN INCHES		SIZE CODE IDENT NO.	
TOLERANCES ON:		B 30377	
XX DEC. #		SCALE FULL	
XXX DEC. #		SHEET	
FRACTIONS #		6816 G	
ANGLES #			
MATERIAL			

Figure 13 PCM Decoder Box

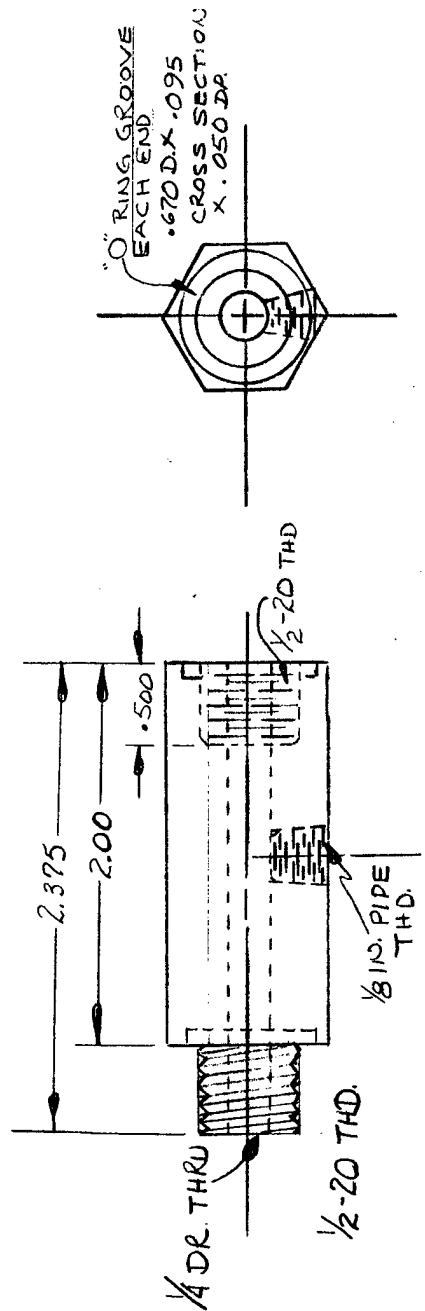

MADE OF 3/4 S.S. HEX STOCK

Figure 14 Basic Pressure Transducer Fittings

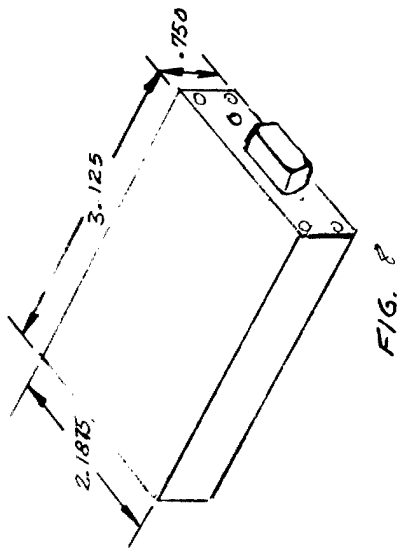
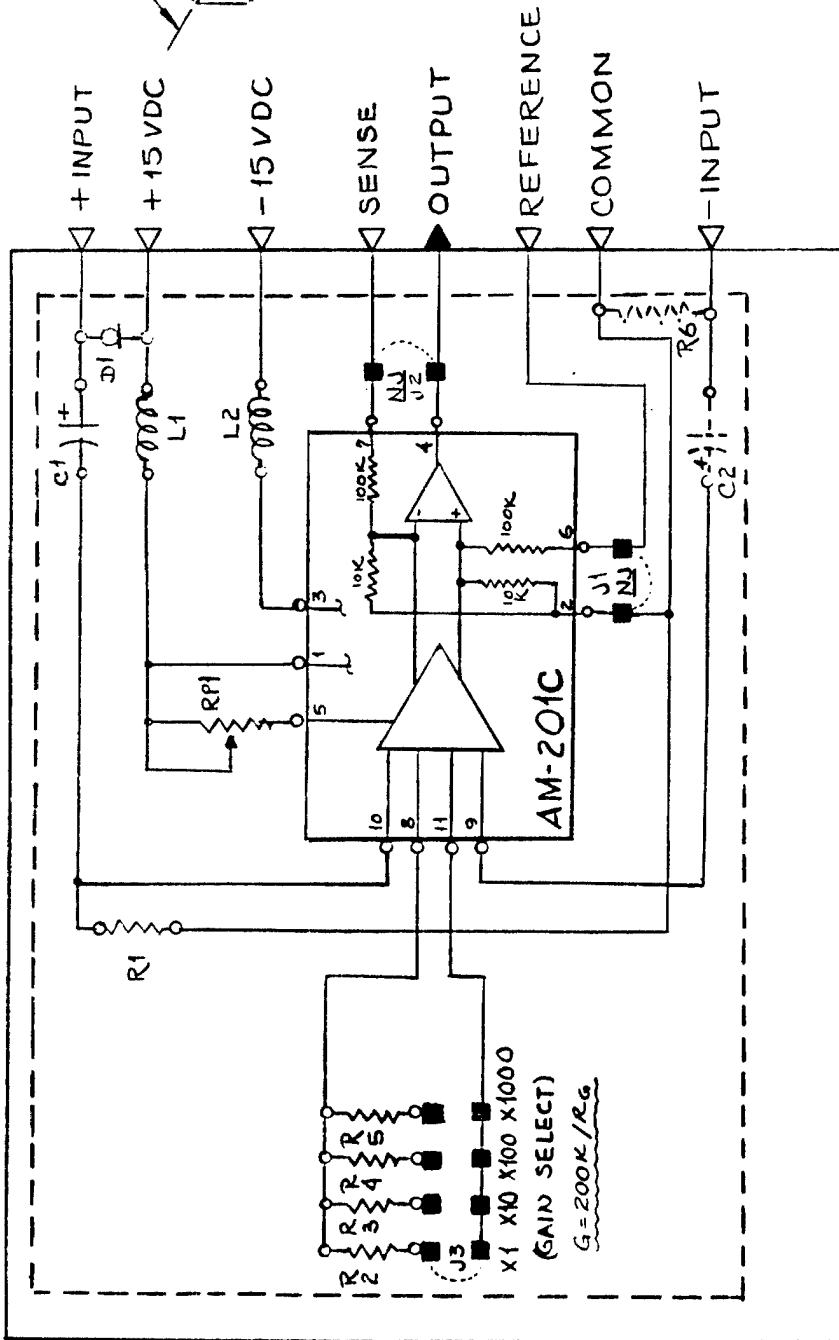
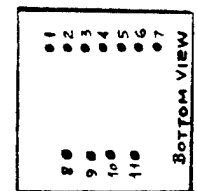

FIG. 8



- (1) +15V (IN)
- (2) COMMON
- (3) -15V (IN)
- (4) OUTPUT
- (5) TRIM
- (6) REFERENCE
- (7) SENSE
- (8)  $R_G = 200/R_6$
- (9) -INPUT
- (10) +INPUT
- (11)  $R_G$

UNIT CONNECTOR  
(DE-9S CINCH)

- 1 -15VDC (BRN)
- 2 COMMON (BLK)
- 3 REFERENCE (WHT)
- 4 OUTPUT (GRY)
- 5 SENSE (VIO)
- 6 -INPUT (BLU)
- 7 +INPUT (GRN)
- 8 +15VDC (YEL)
- 9 CHASSIS (BARE)

Figure 15 Amplifier Box and Schematic

PARTS LIST

- C1, C2 1 $\mu$ f @ 50VDC
- L1, L2 1 $\mu$ h.
- R1 33 K
- R2 200 K
- R3 20 K
- R4 2 K
- R5 200 $\Omega$
- R6 10  $\Omega$
- RP1 50 K
- D1 1N5313

NOTES!

- (1) D1 - { +IN - || - +15VDC } - O -
- (2) ■ JUMPER POINT
- (3) NJ = NORMALLY JUMPERED
- (4) ▲ AMPLIFIER OUTPUT
- (5) DOTTED COMPONENTS REMOVED OR ADDED FOR INPUT CONFIGURATION.

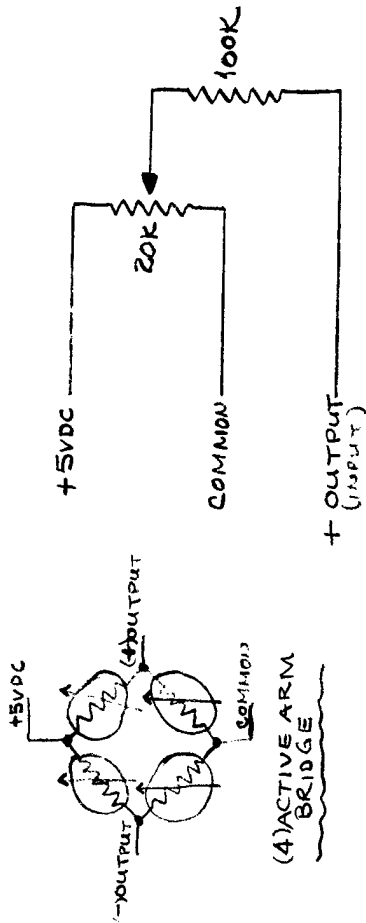

FIG. 10

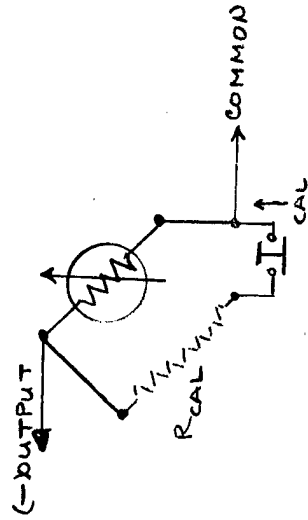

Figure 16 Bridge Balance and Shunt Cal Circuits

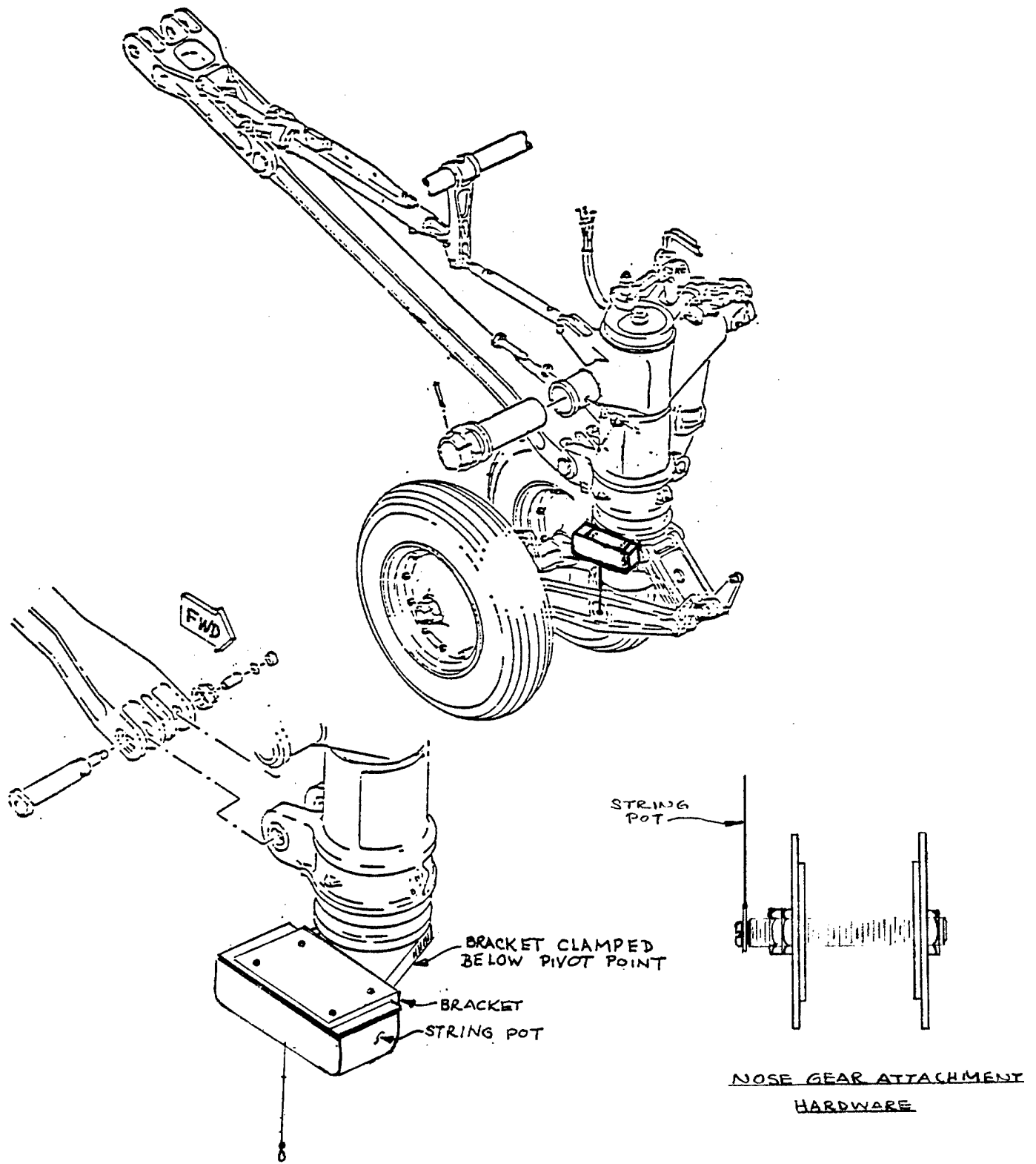

Figure 17 Nose Gear String Pot Mounting

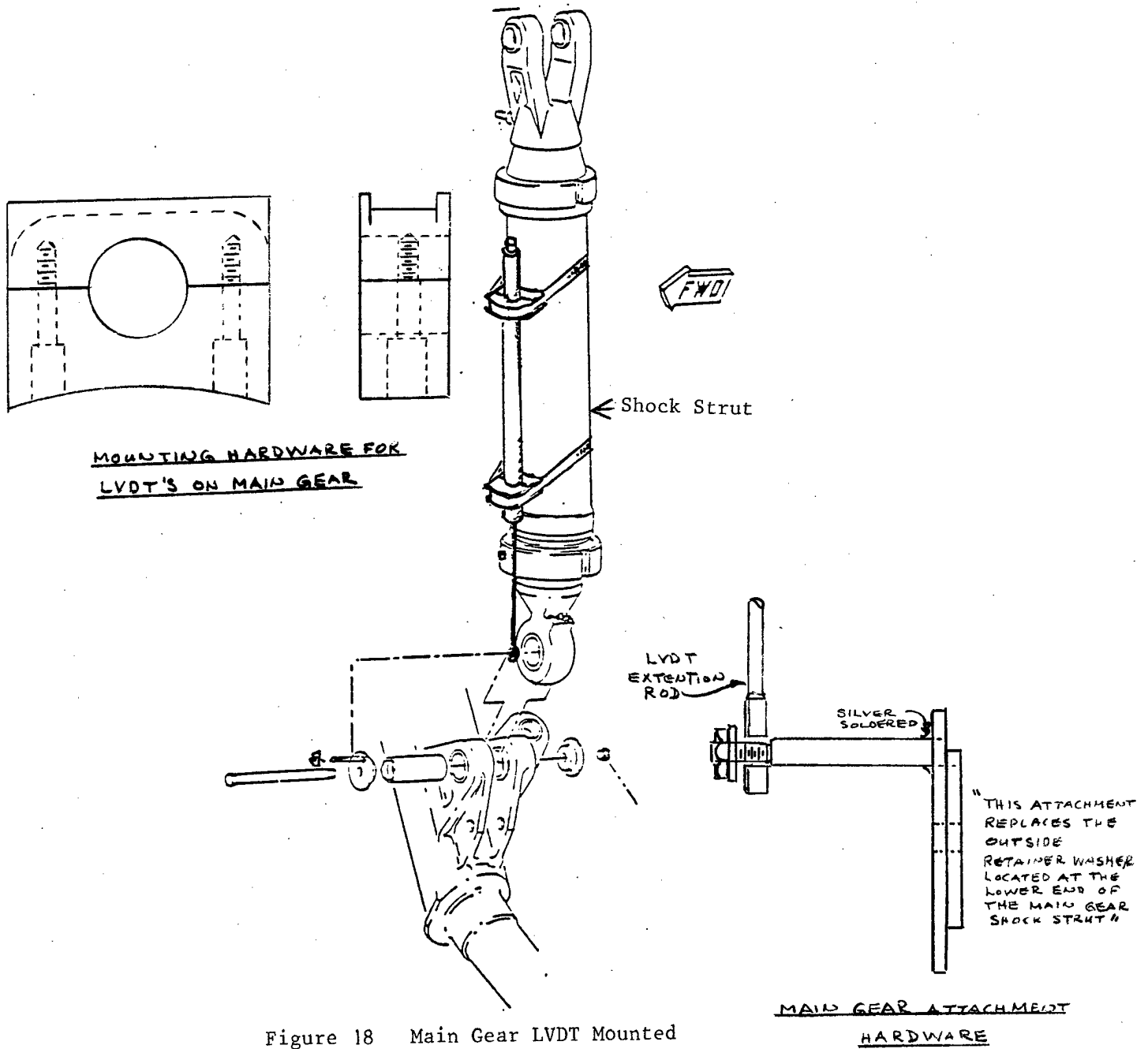

Figure 18 Main Gear LVDT Mounted

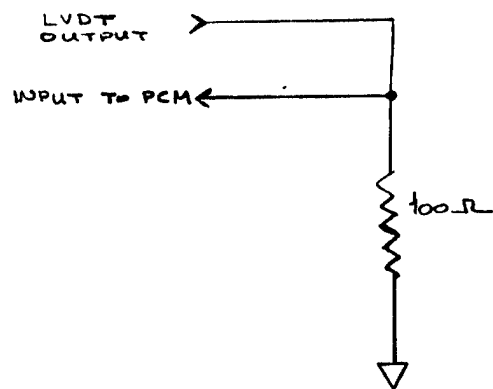

Figure 19 LVDT Voltage Divider

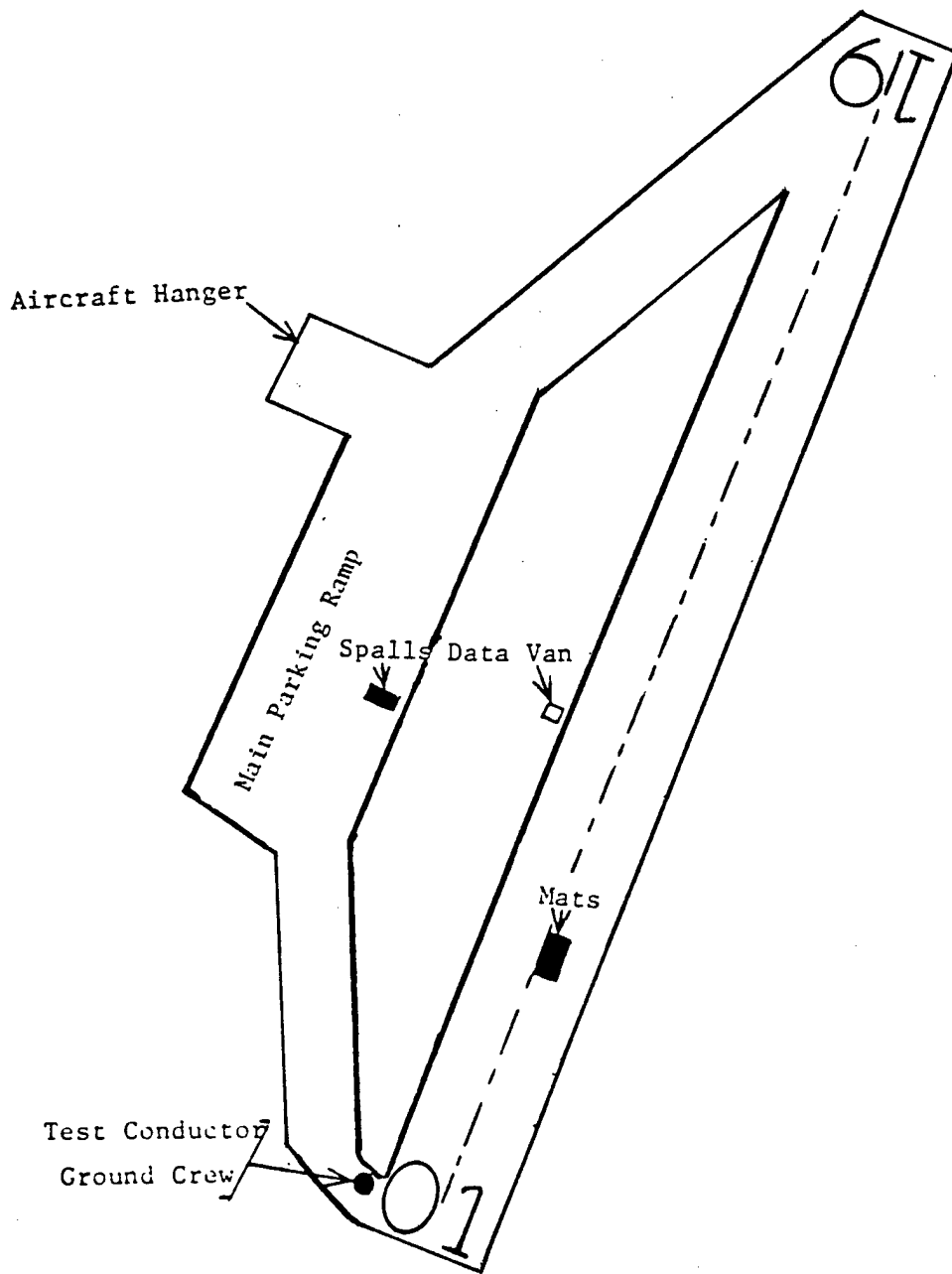
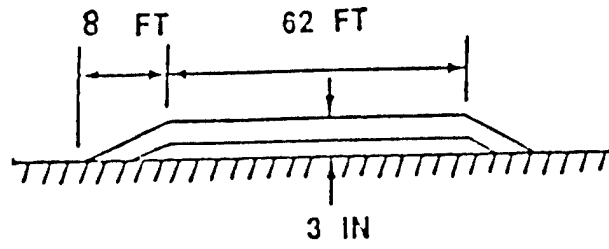
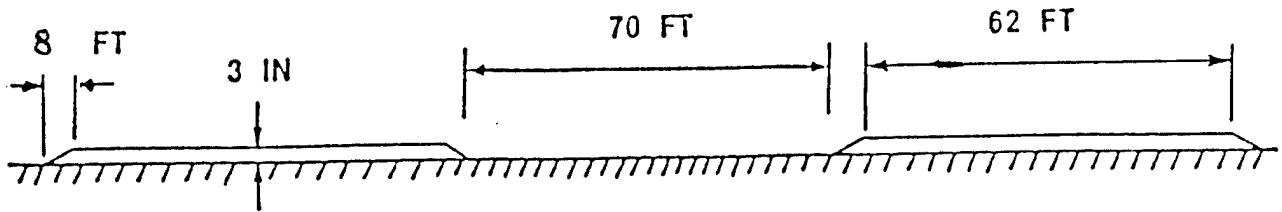

Figure 20 Whiteman AFB, MO A-7D HAVE  
BOUNCE Test General Locations



**SINGLE MAT**

1 - 3 inch BUMP



**DOUBLE MAT**

2 - 3 inch BUMPS

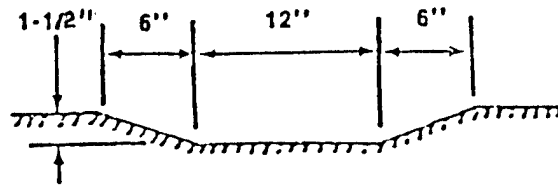

**SPALL**

Figure 21 Proposed Bump Profiles

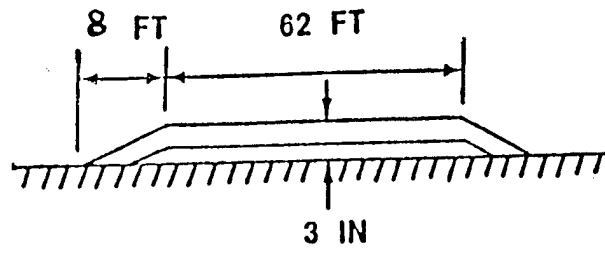

**SINGLE MAT**  
1 - 3 inch BUMP

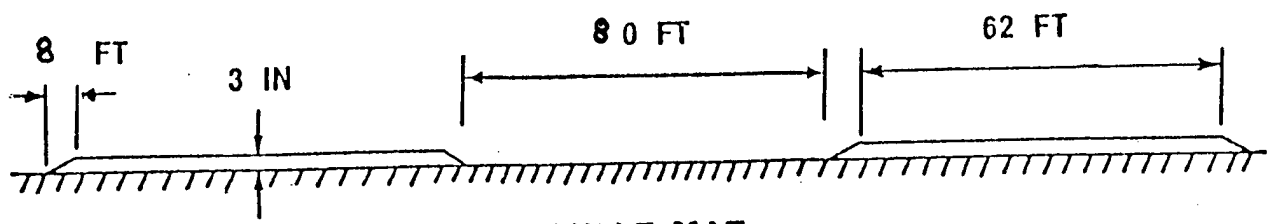

**DOUBLE MAT**  
2 - 3 inch BUMPS

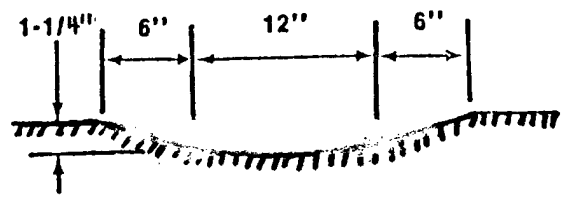

SPALL

Figure 22 Bump Profiles as Tested

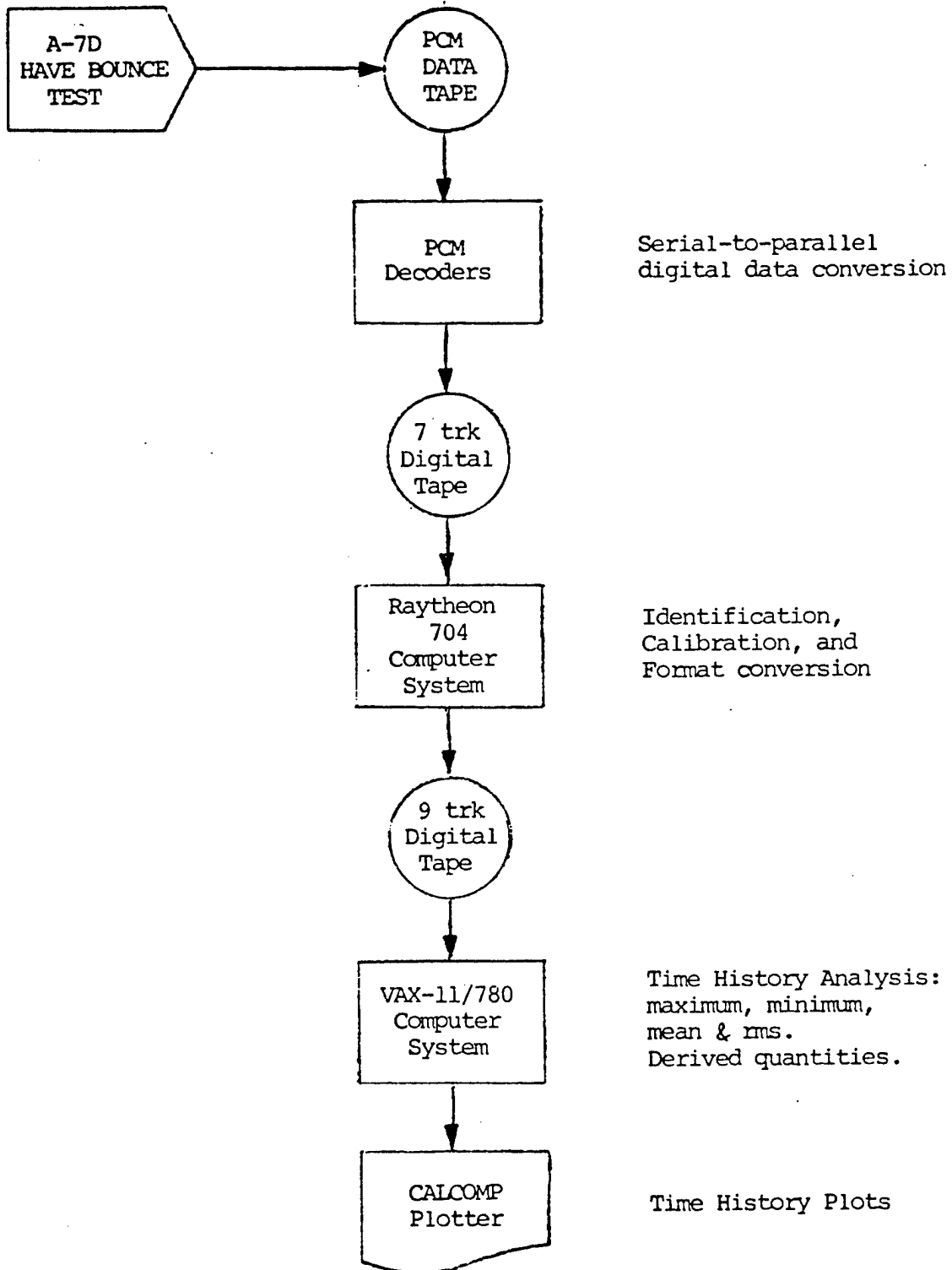
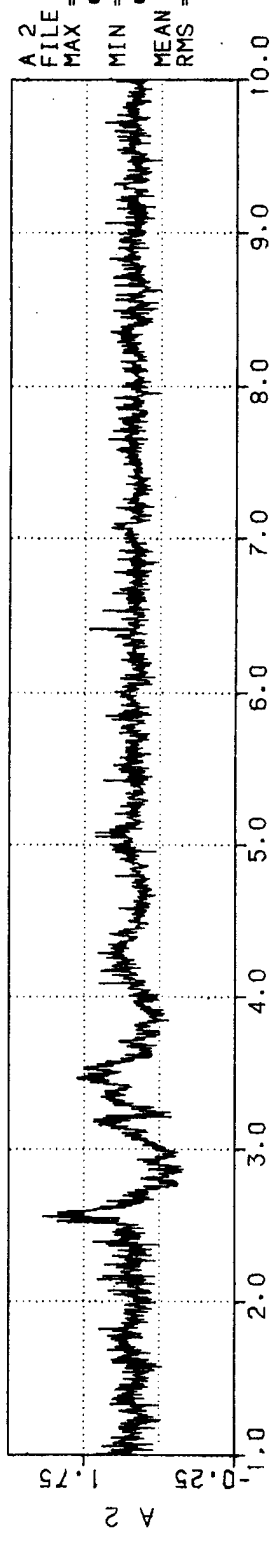
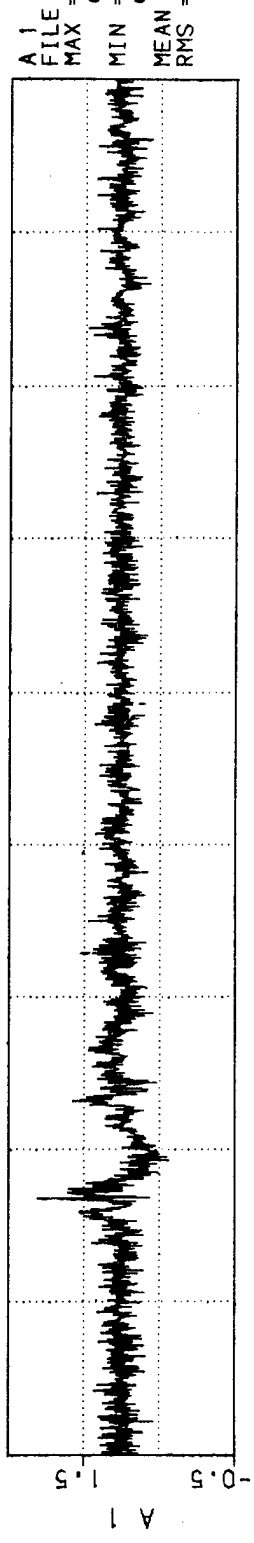
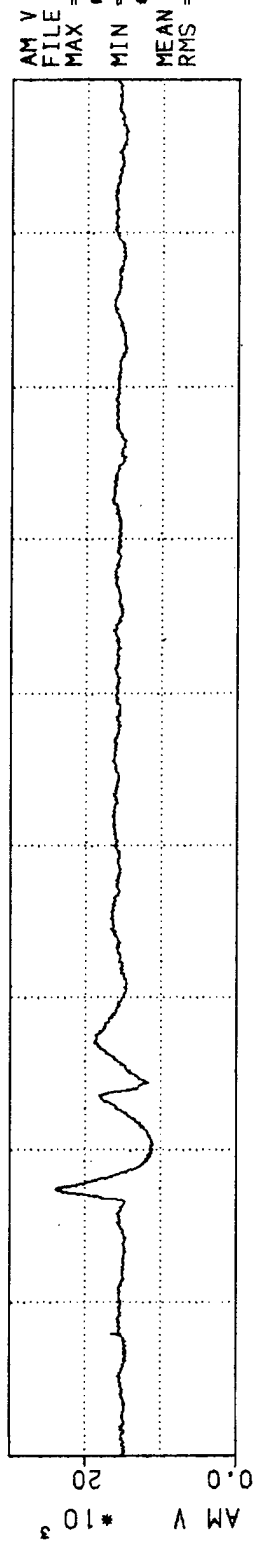
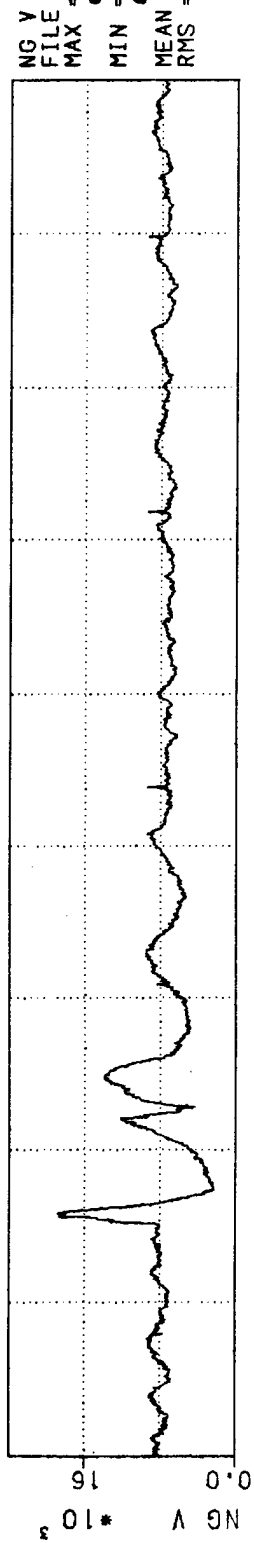

Figure 23 Data Reduction Procedure

A-7D HAVE BOUNCE TEST: WHITEMAN AFB  
 60 KNOTS : SINGLE BUMP : HEAVY WEIGHT



TIME - SECONDS  
 DELTA T (MSEC) = 5.120  
 Figure 24 Page One of Run No. 34

A-7D HAVE BOUNCE TEST: WHITEMAN AFB

60 KNOTS : SINGLE BUMP : HEAVY WEIGHT

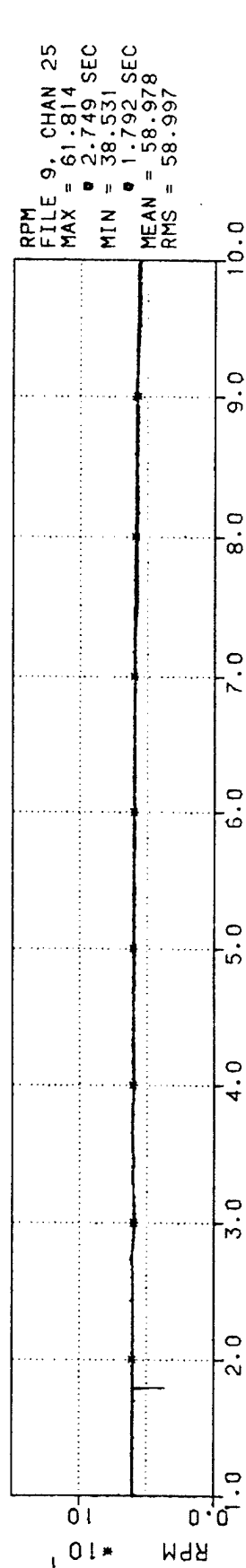
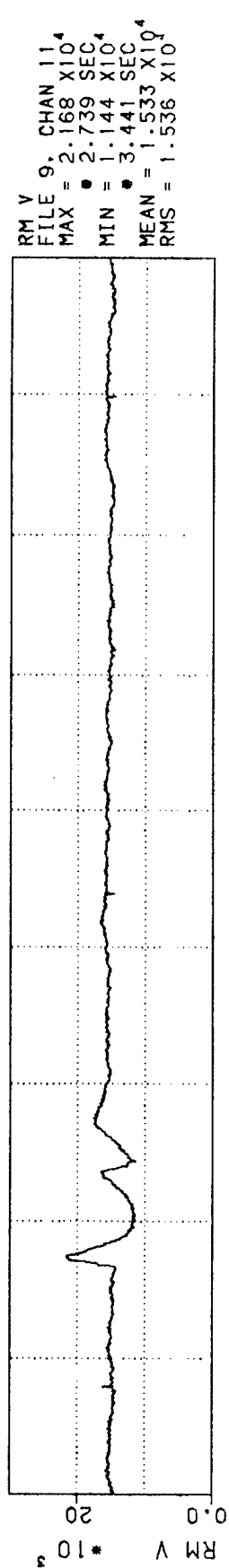
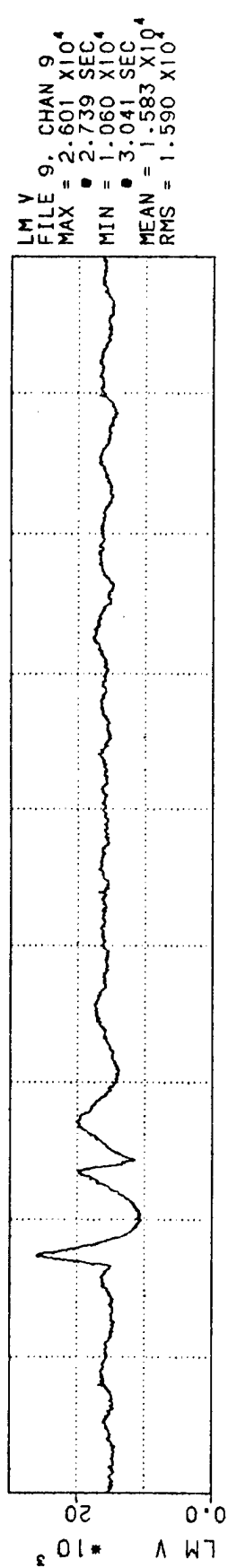
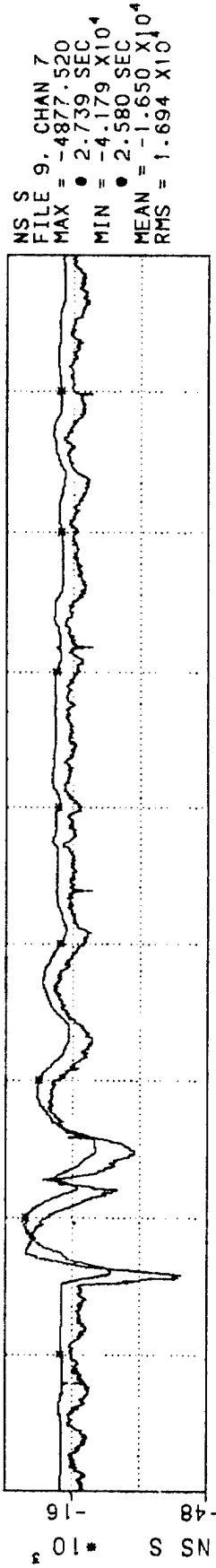
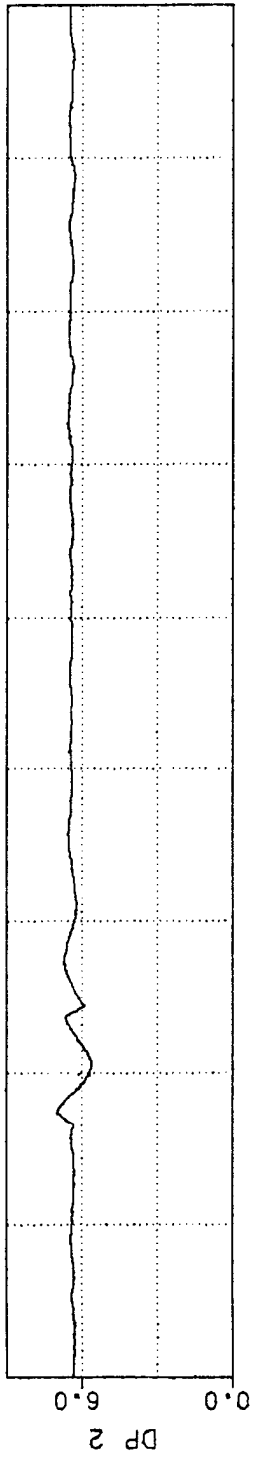
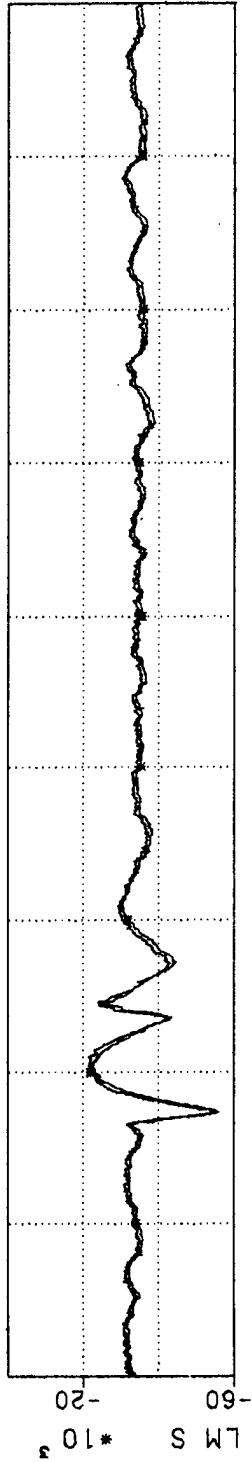

Figure 25 Page Two of Run No. 34  
DELTA T (MSEC) = 5.120

A-7D HAVE BOUNCE TEST: WHITEMAN AFB  
 60 KNOTS : SINGLE BUMP : HEAVY WEIGHT



DP 2  
 FILE 9, CHAN 22  
 MAX = 6.969  
 • 2.744 SEC  
 MIN = 5.620  
 • 3.041 SEC  
 MEAN = 6.406  
 RMS = 6.408



LM S  
 FILE 9, CHAN 9  
 MAX = -2.221 X 10<sup>4</sup>  
 • 3.041 SEC  
 MIN = -5.600 X 10<sup>4</sup>  
 • 2.739 SEC  
 MEAN = -3.371 X 10<sup>4</sup>  
 RMS = 3.387 X 10<sup>4</sup>

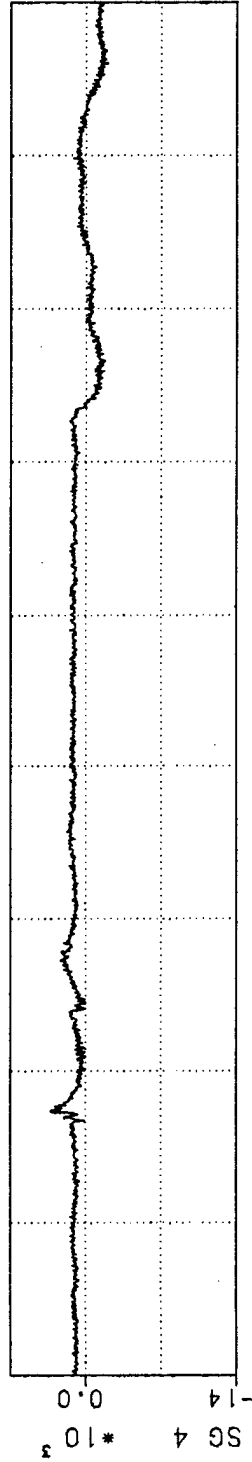

SG 4  
 FILE 9, CHAN 10  
 MAX = 3257.453  
 • 2.739 SEC  
 MIN = -2004.922  
 • 9.605 SEC  
 MEAN = 645.876  
 RMS = 1059.971

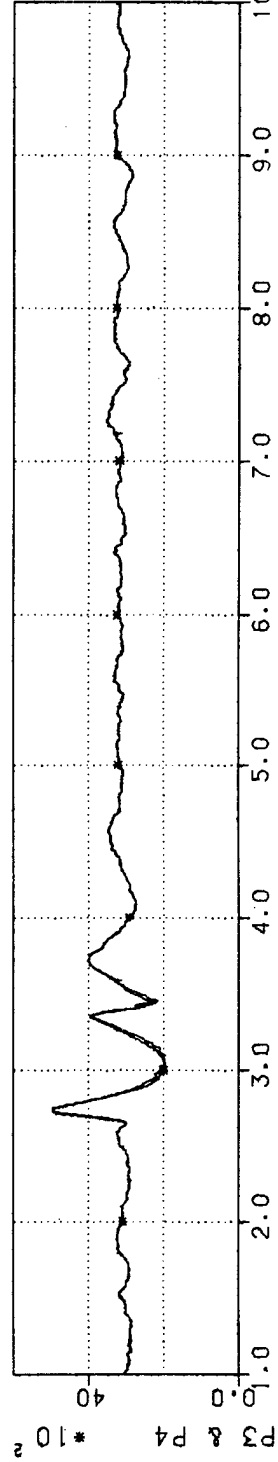

P3 & P4  
 FILE 9, CHAN 15  
 MAX = 4946.397  
 • 2.755 SEC  
 MIN = 1945.673  
 • 3.036 SEC  
 MEAN = 3133.013  
 RMS = 3149.127

TIME - SECONDS  
 Page Three of Run No. 34  
 DELTA T (MSEC) = 5.120

A-7D HAVE BOUNCE TEST: WHITEMAN AFB

60 KNOTS : SINGLE BUMP : HEAVY WEIGHT

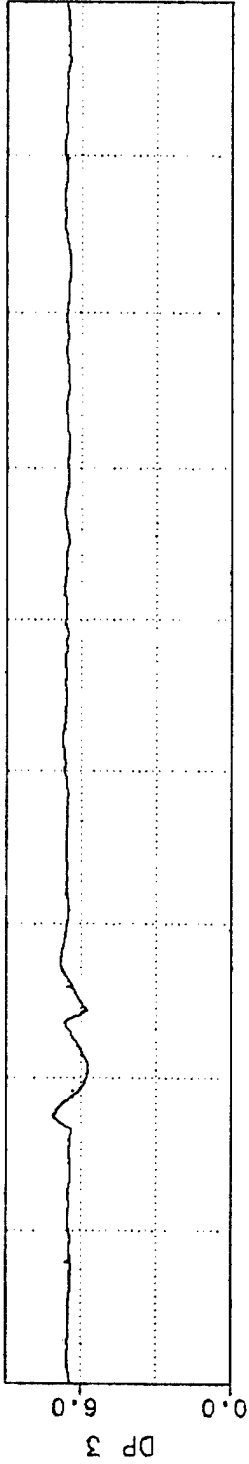

DP 3  
FILE 9, CHAN 23  
MAX = 7.110  
MIN = 5.727  
MEAN = 6.534  
RMS = 6.537

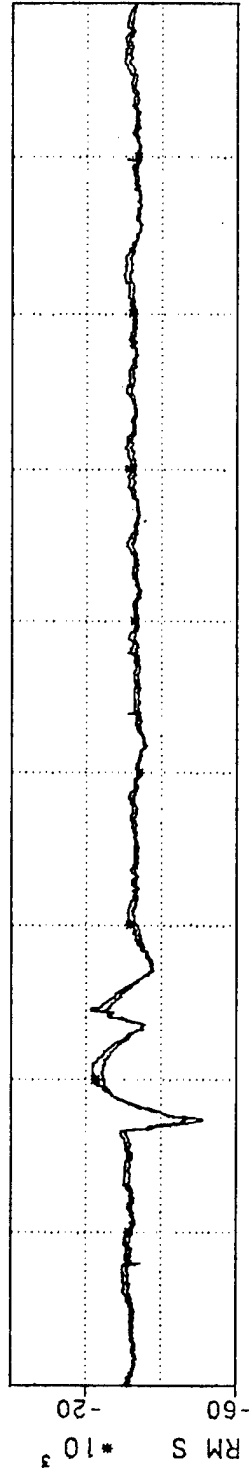

RM S  
FILE 9, CHAN 11  
MAX = -2.404 X10<sup>4</sup>  
MIN = -4.678 X10<sup>4</sup>  
MEAN = -3.274 X10<sup>4</sup>  
RMS = 3.282 X10<sup>4</sup>

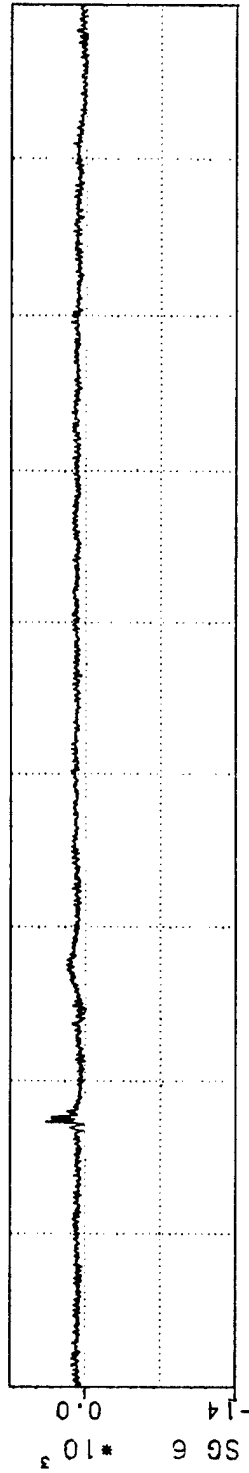

SG 6  
FILE 9, CHAN 12  
MAX = 3717.793  
MIN = -180.617  
MEAN = 9.672 SEC  
RMS = 822.536

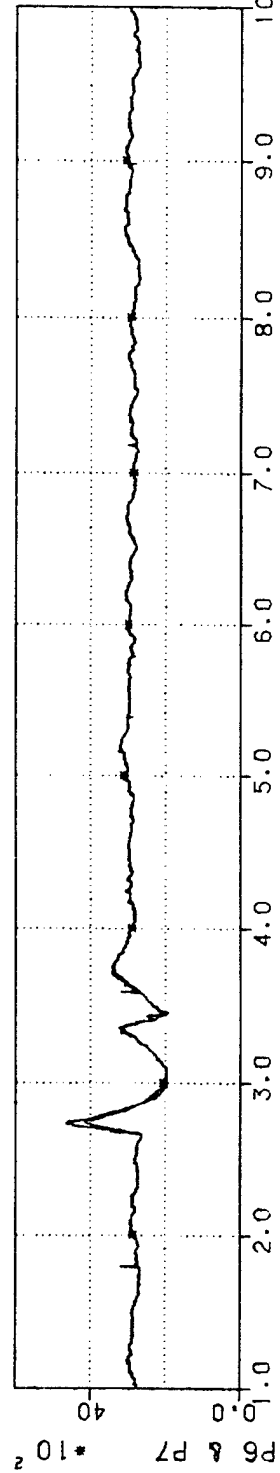

P6 & P7  
FILE 9, CHAN 18  
MAX = 4150.025  
MIN = 1949.719  
MEAN = 2874.431  
RMS = 2884.117

TIME - SECONDS

DELTA T (MSEC) = 5.120

Figure 27 Page Four of Run No. 34

A-7D HAVE BOUNCE TEST: WHITEMAN AFB

60 KNOTS : SINGLE BUMP : HEAVY WEIGHT

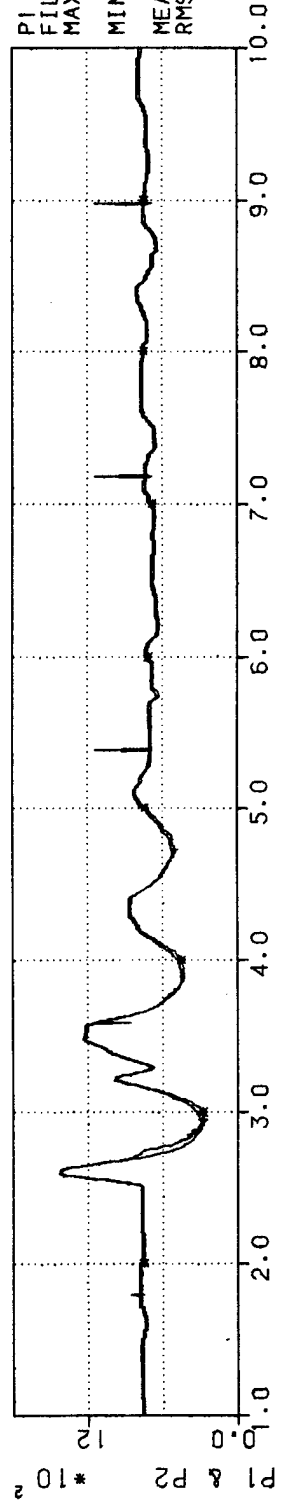
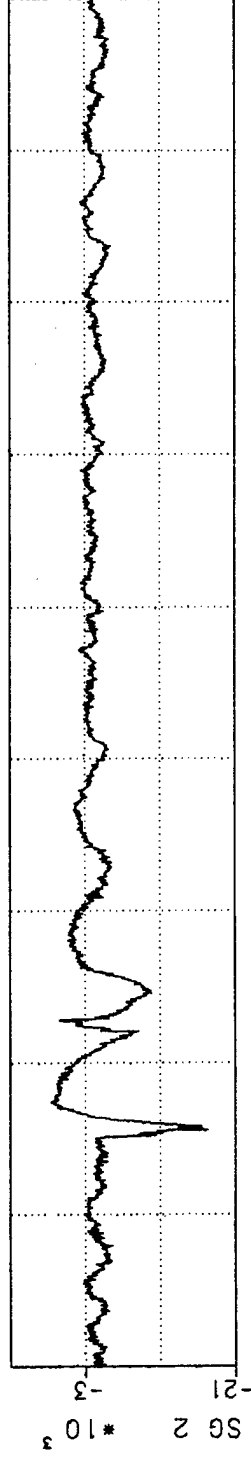
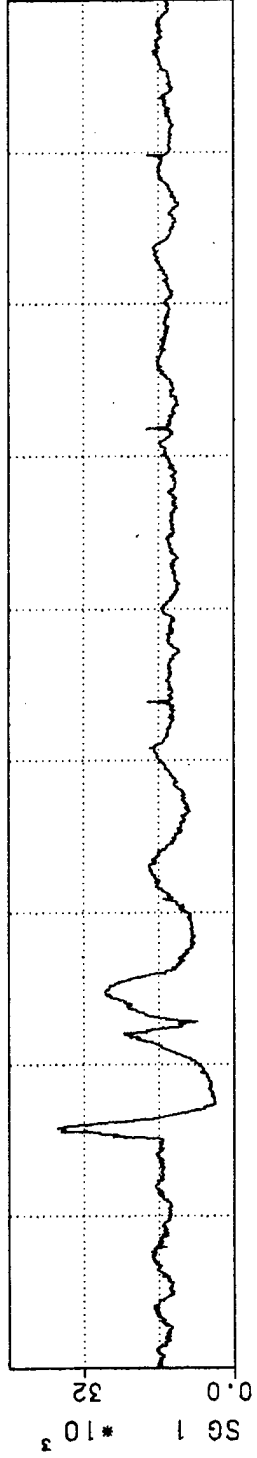
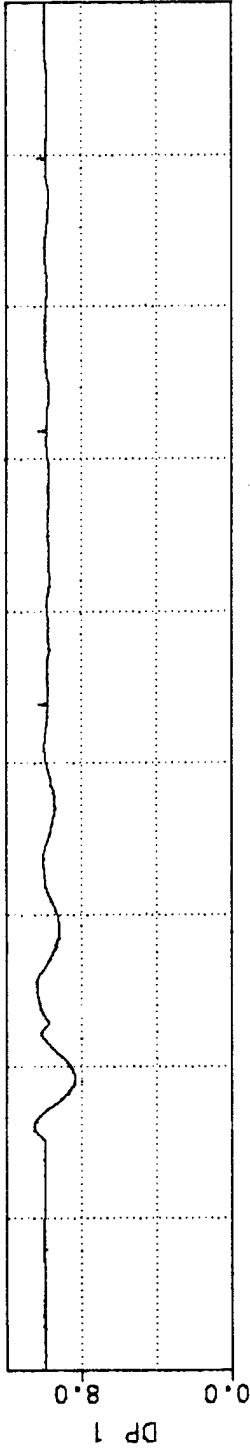

TIME - SECONDS  
Page Five of Run No. 34  
DELTA T (MSEC) = 5.120

A-7D HAVE BOUNCE TEST: WHITEMAN AFB

60 KNOTS : SINGLE BUMP : HEAVY WEIGHT

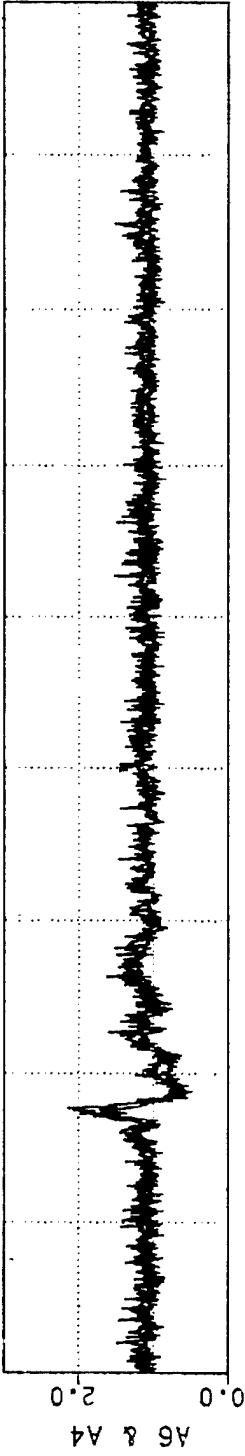

A6 & A4  
FILE 9, CHAN 6  
MAX = 1.801  
MIN = 2.714 SEC  
MEAN = 0.530  
RMS = 2.918 SEC  
RMS = 1.048  
RMS = 1.054

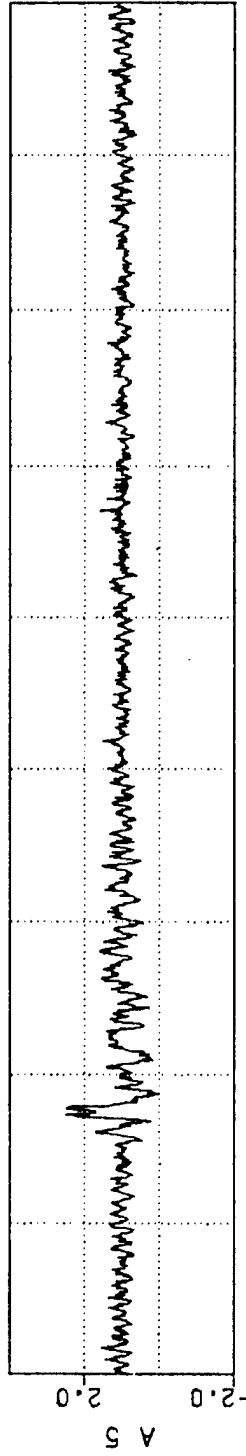

A 5  
FILE 9, CHAN 5  
MAX = 2.469  
MIN = 2.780 SEC  
MEAN = 8.026 X10<sup>-3</sup>  
RMS = 2.872 SEC  
RMS = 0.983  
RMS = 1.007

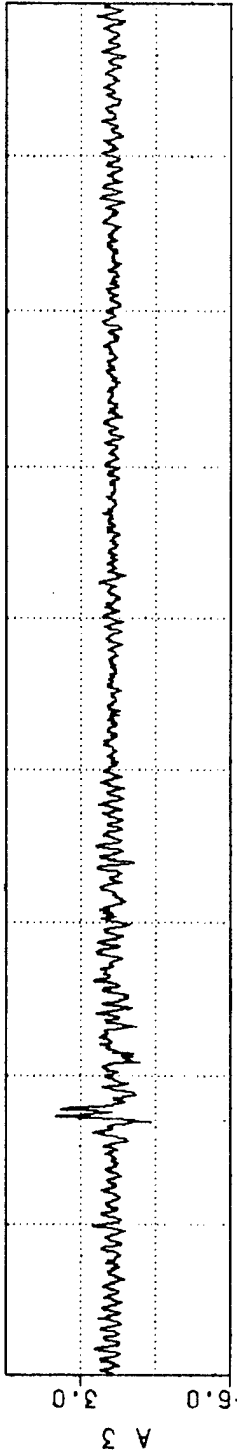

A 3  
FILE 9, CHAN 3  
MAX = 4.446  
MIN = 2.729 SEC  
MEAN = -1.243  
RMS = 2.698 SEC  
RMS = 1.104  
RMS = 1.178

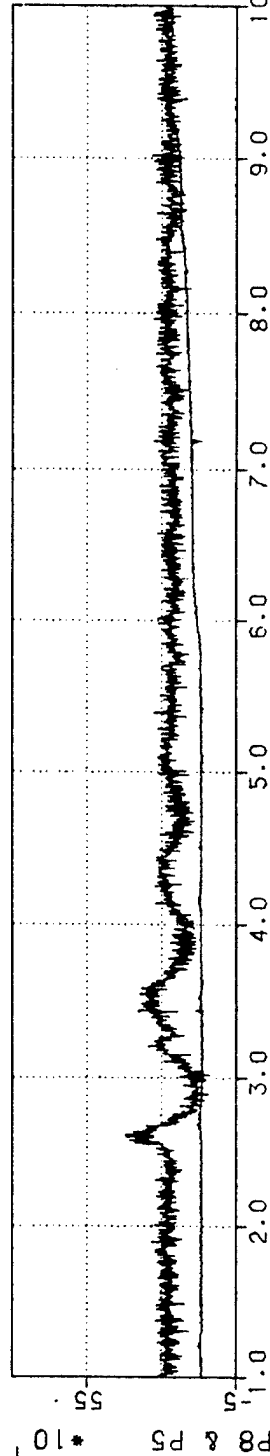

P8 & P5  
FILE 9, CHAN 20  
MAX = 250.010  
MIN = 9.585 SEC  
MEAN = 84.122  
RMS = 3.420 SEC  
RMS = 122.795  
RMS = 129.792

TIME - SECONDS

DELTA T (MSEC) = 5.120

Figure 29 Page Six of Run No. 34

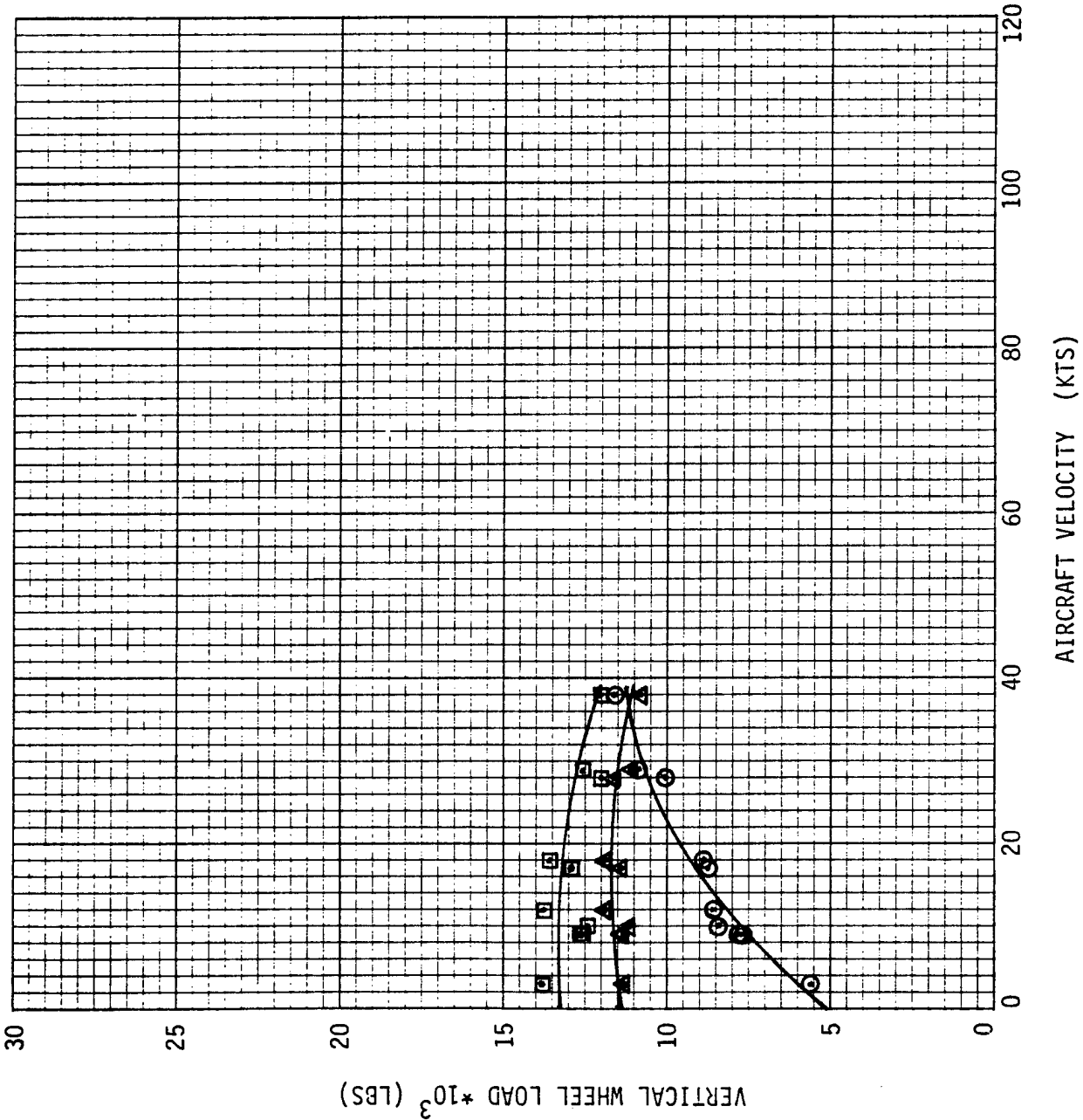

Figure 30 Load Vs. Velocity, Landing Wt., Spall Profile

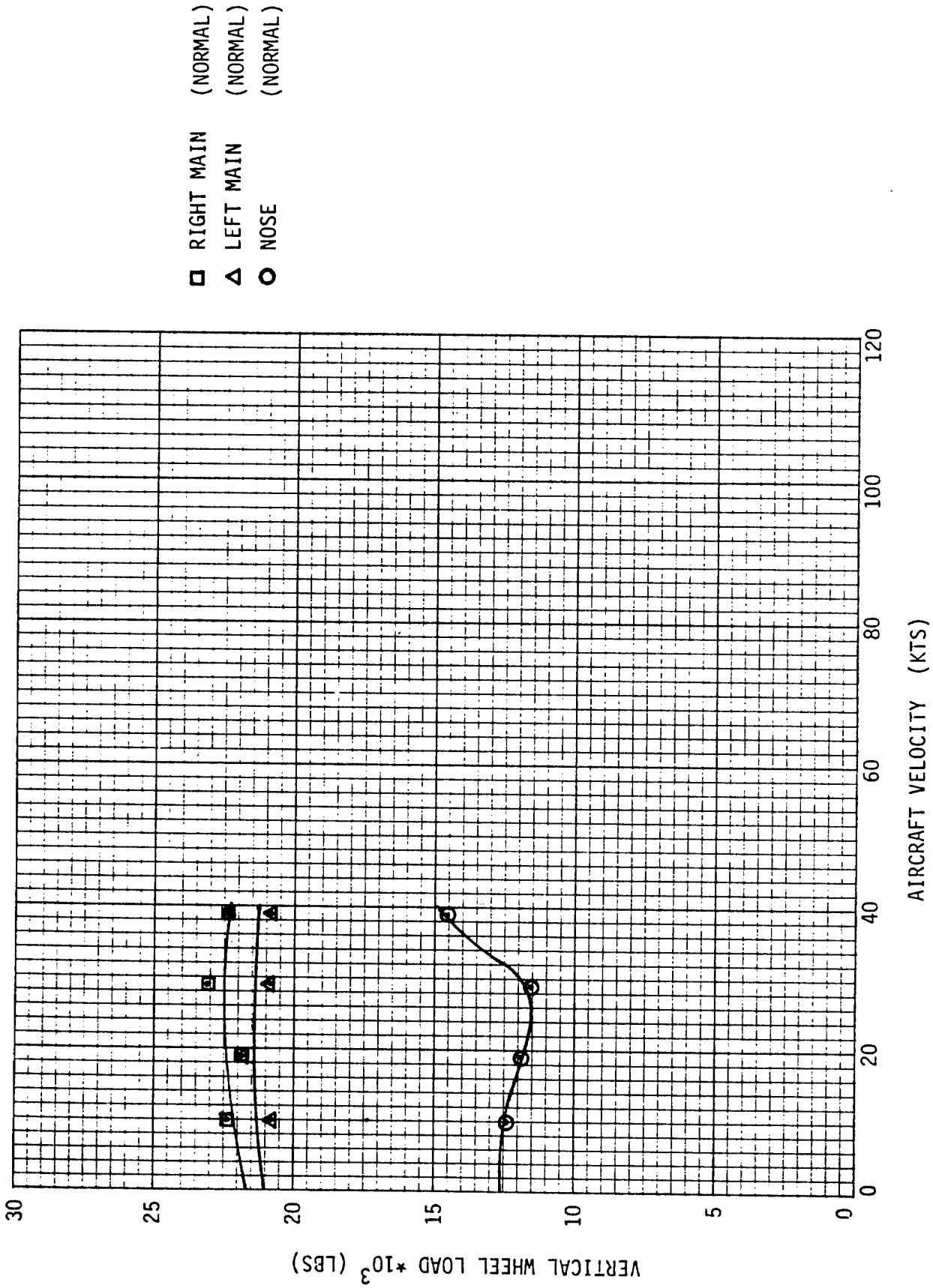

Figure 31 Load Vs. Velocity, Take-Off Wt., Spall Profile

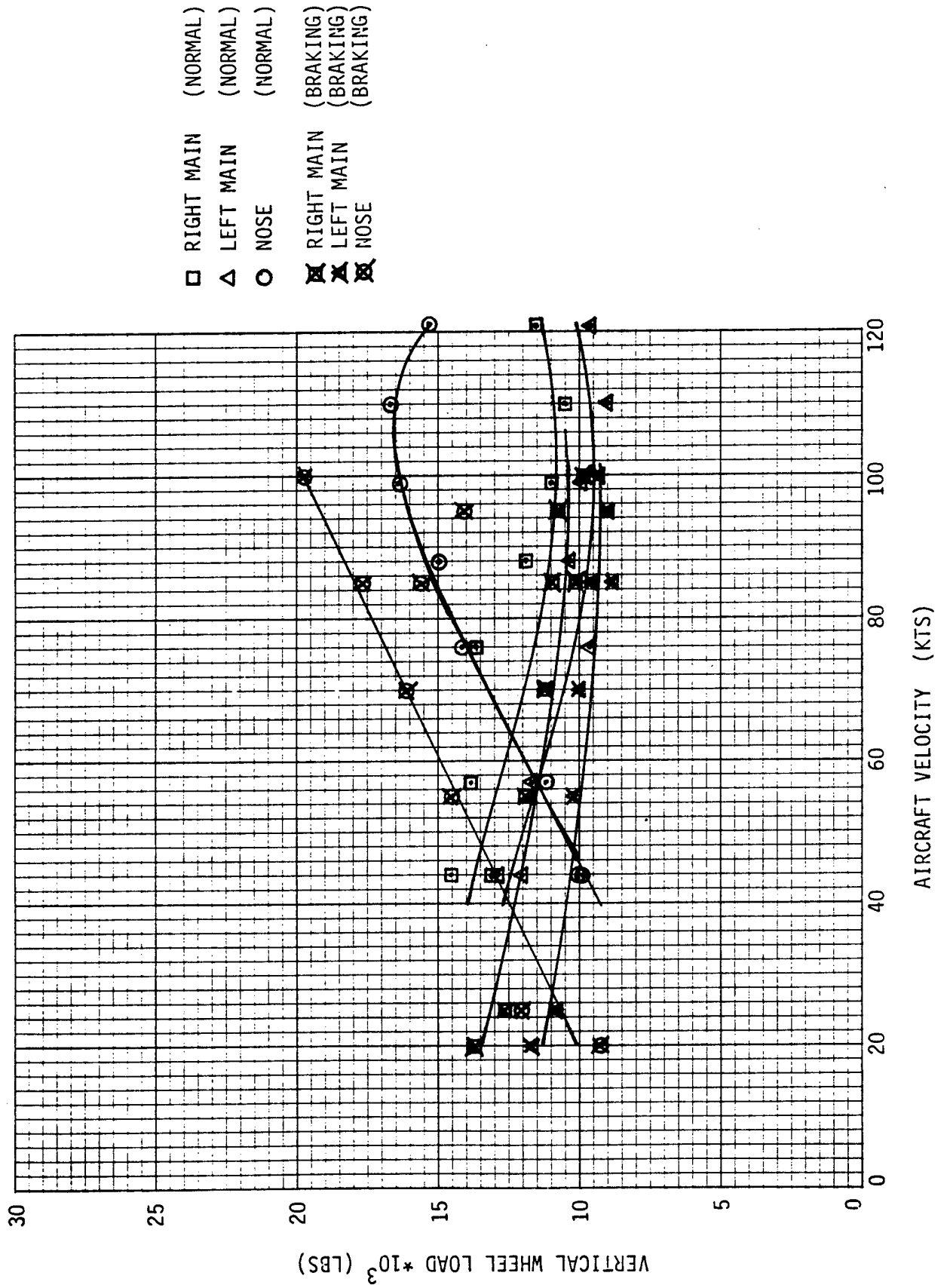

Figure 32 Load Vs. Velocity, Landing Wt., 1-3" Bump Profile

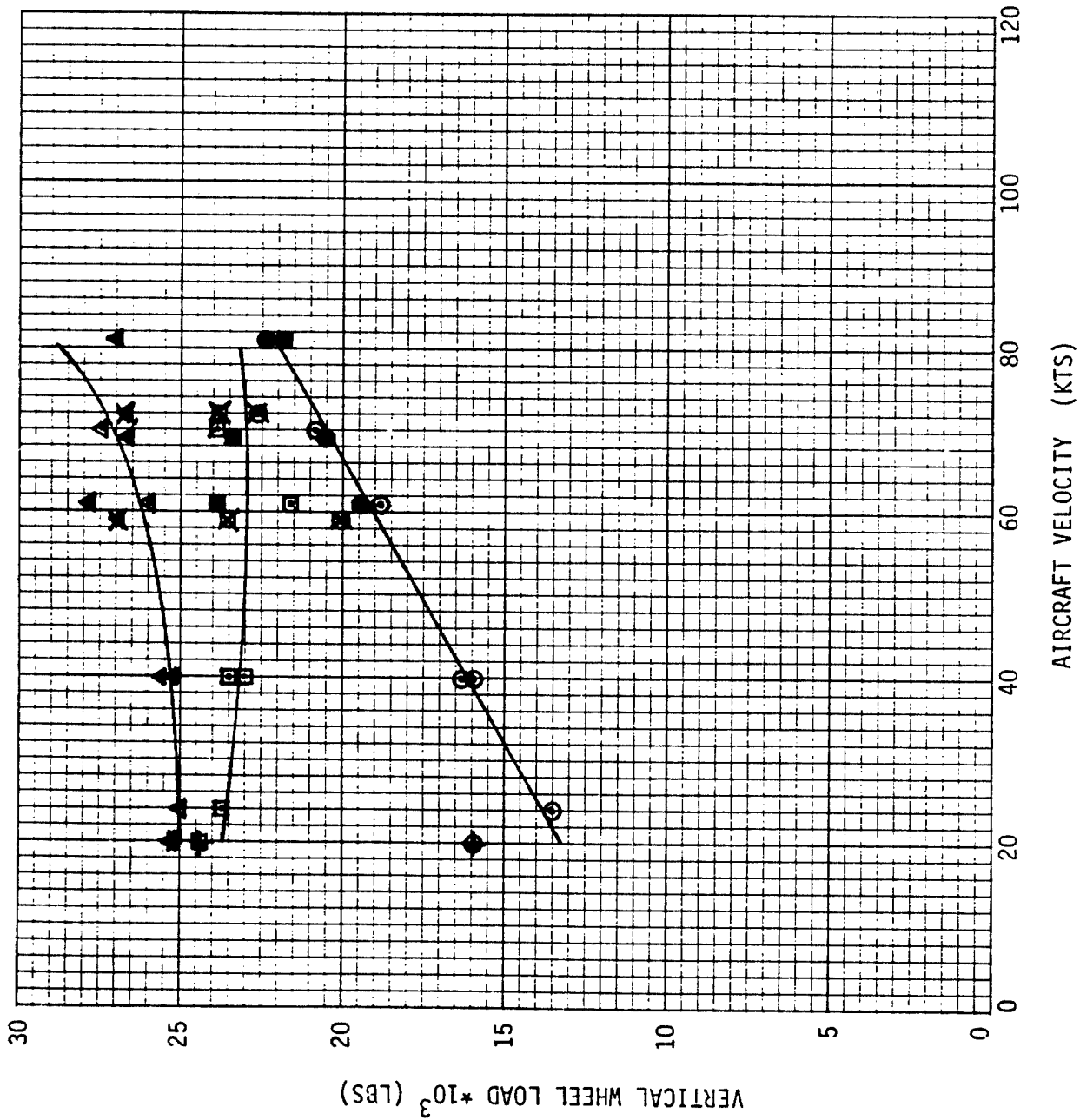

Figure 33 Load Vs. Velocity, Take-Off Wt., 1-3" Bump Profile

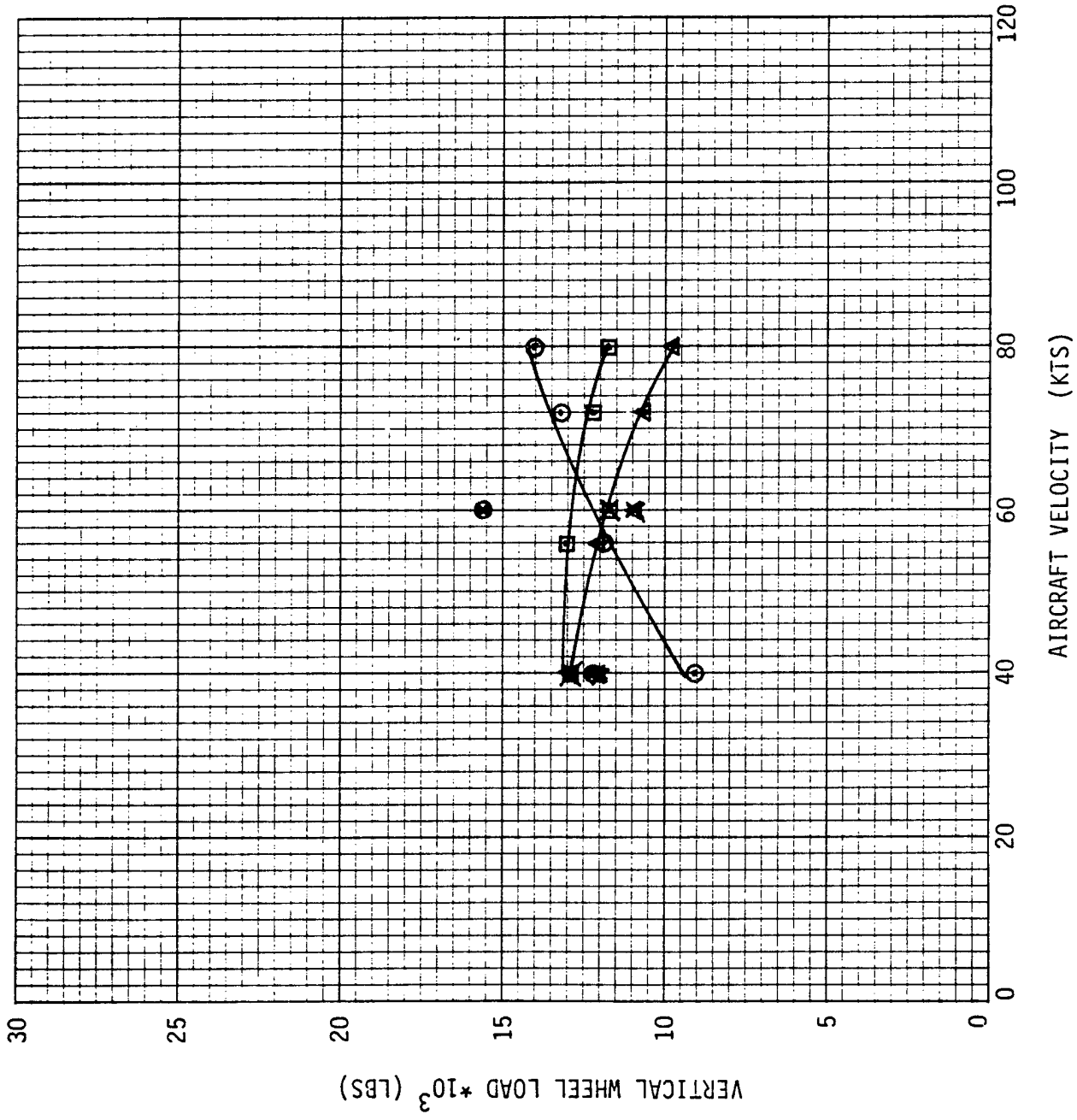

Figure 34 Load Vs. Velocity, Landing Wt., 2-3" Bump Profile

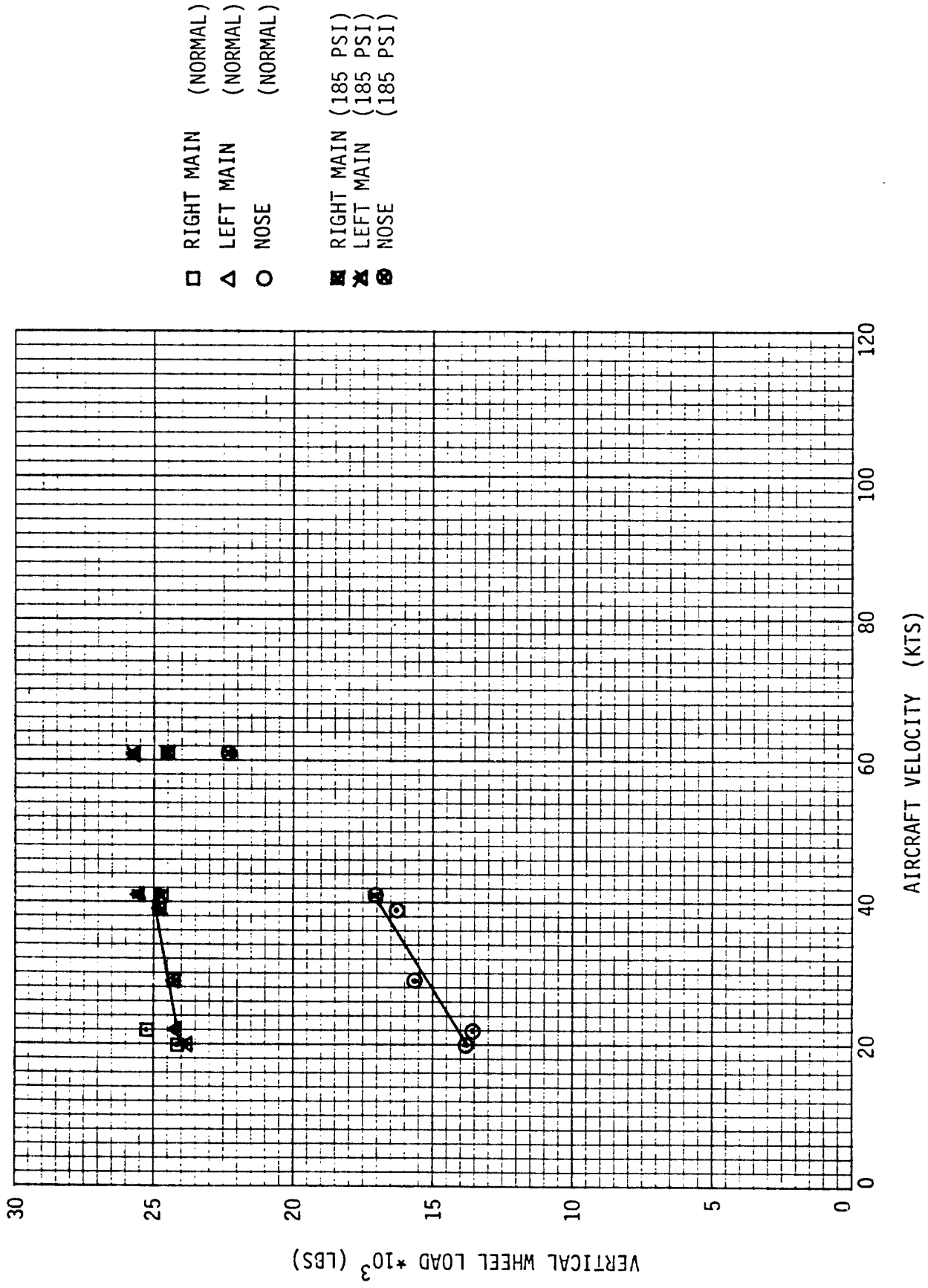
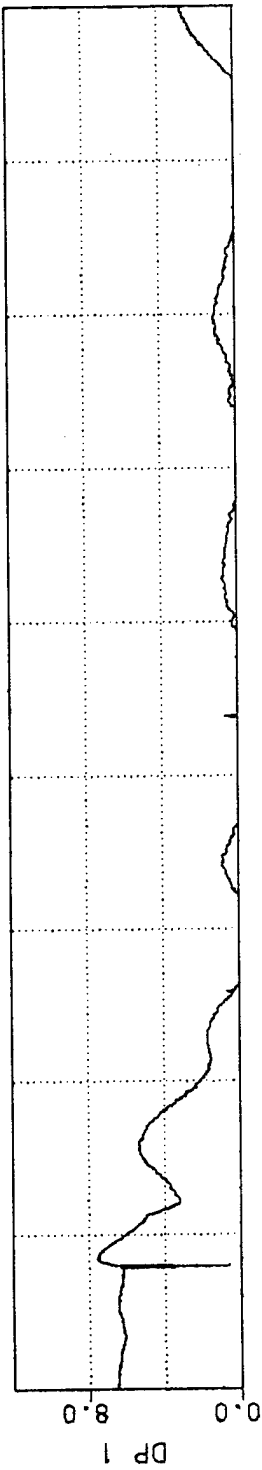
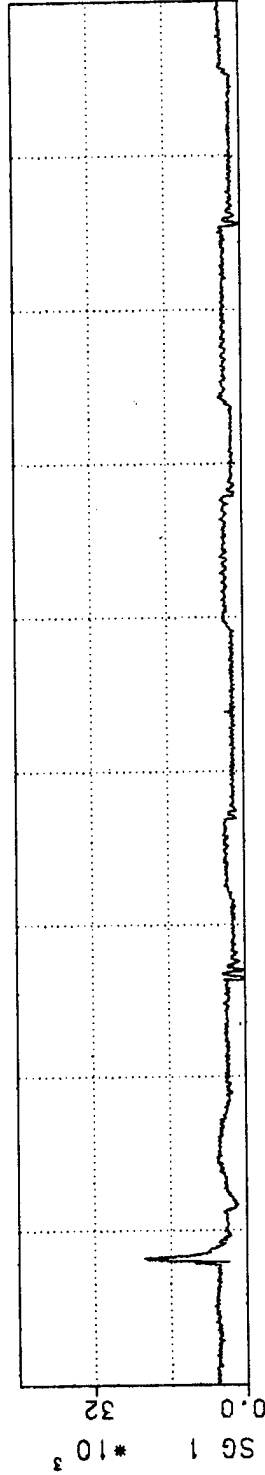

Figure 35 Load Vs. Velocity, Take-Off Mt., 2-3" Bump Profile

A-7D HAVE BOUNCE TEST • WHITE MAN AFB  
 120 KNOTS : SINGLE BUMP : LIGHT WEIGHT



DP 1  
 FILE 18, CHAN 21  
 MAX = 7.538  
 MIN = 0.000 X10<sup>-101</sup>  
 MEAN = 1.505  
 RMS = 2.676



SG 1  
 FILE 18, CHAN 7  
 MAX = 2.167 X10<sup>4</sup>  
 MIN = 0.000 X10<sup>-101</sup>  
 MEAN = 3540.726  
 RMS = 3885.507

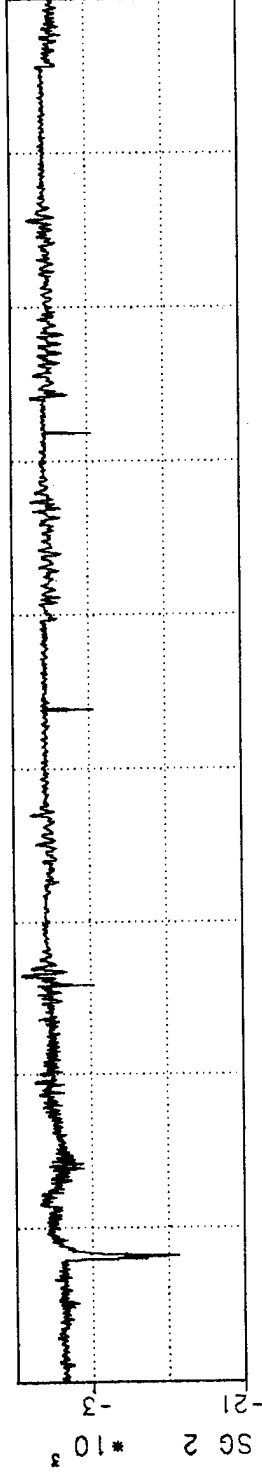

SG 2  
 FILE 18, CHAN 8  
 MAX = 5042.719  
 MIN = -1.330 X10<sup>4</sup>  
 MEAN = 1603.942  
 RMS = 1944.612

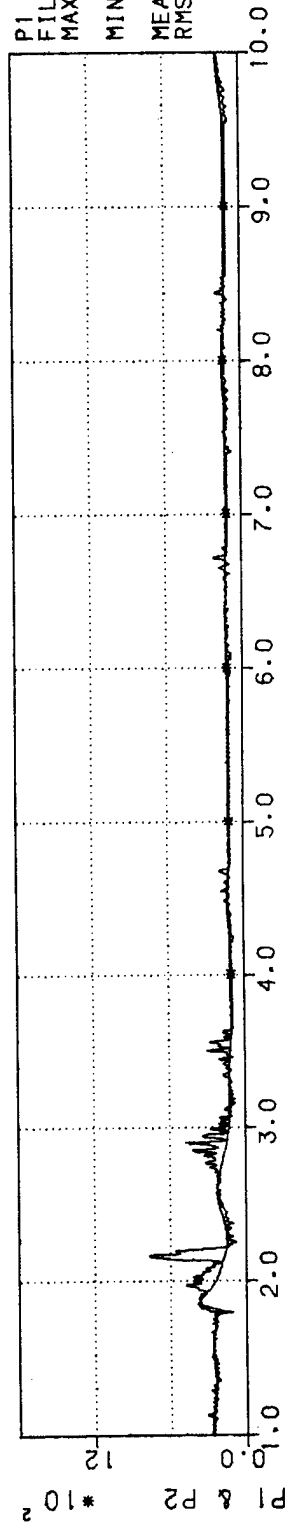

P1 & P2  
 FILE 18, CHAN 13  
 MAX = 380.275  
 MIN = 103.917  
 MEAN = 147.496  
 RMS = 155.707

TIME - SECONDS  
 Page Five of Run No. 22  
 DELTA T (MSEC) = 5.120

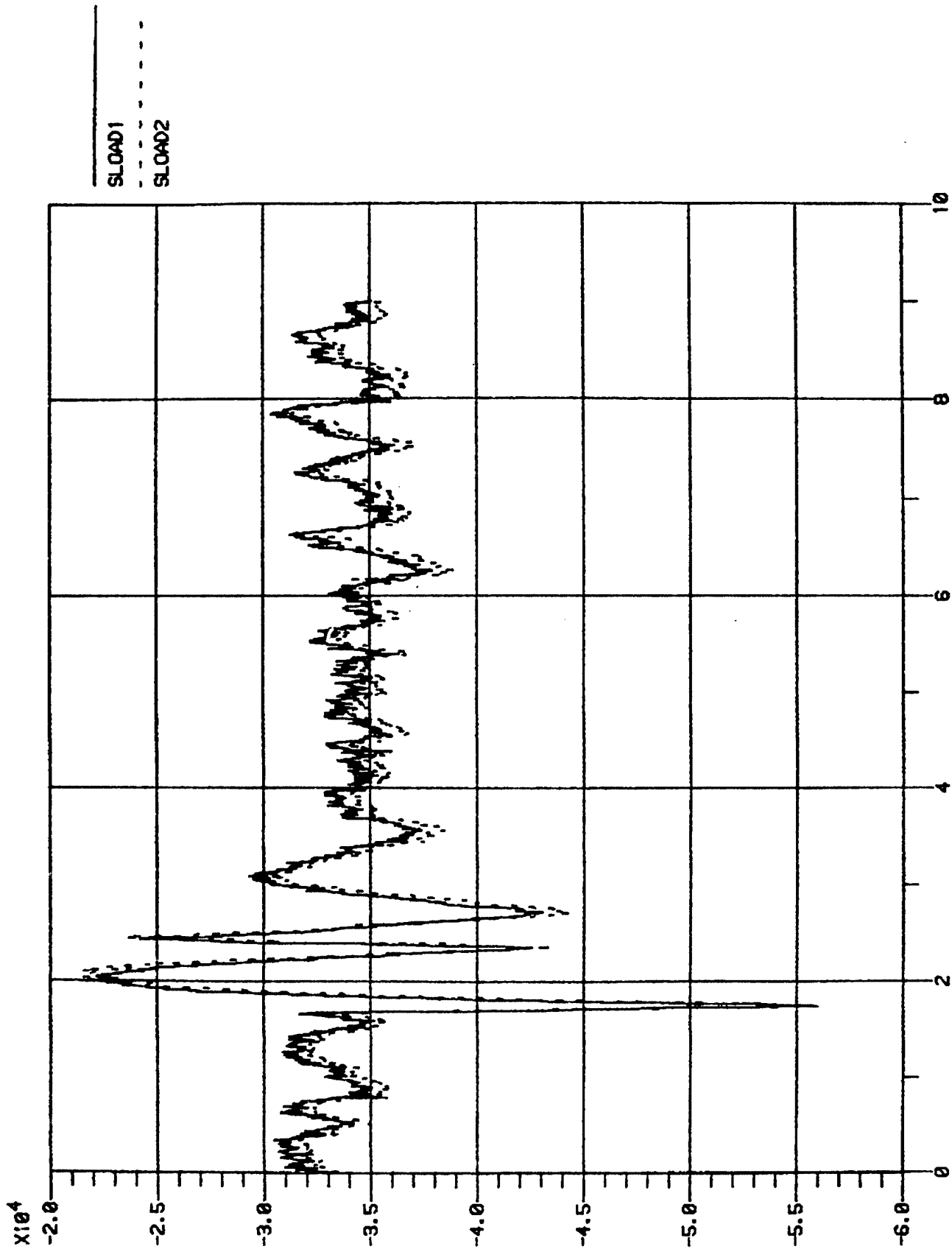

Figure 37 Time History of SLOAD1 and SLOAD2

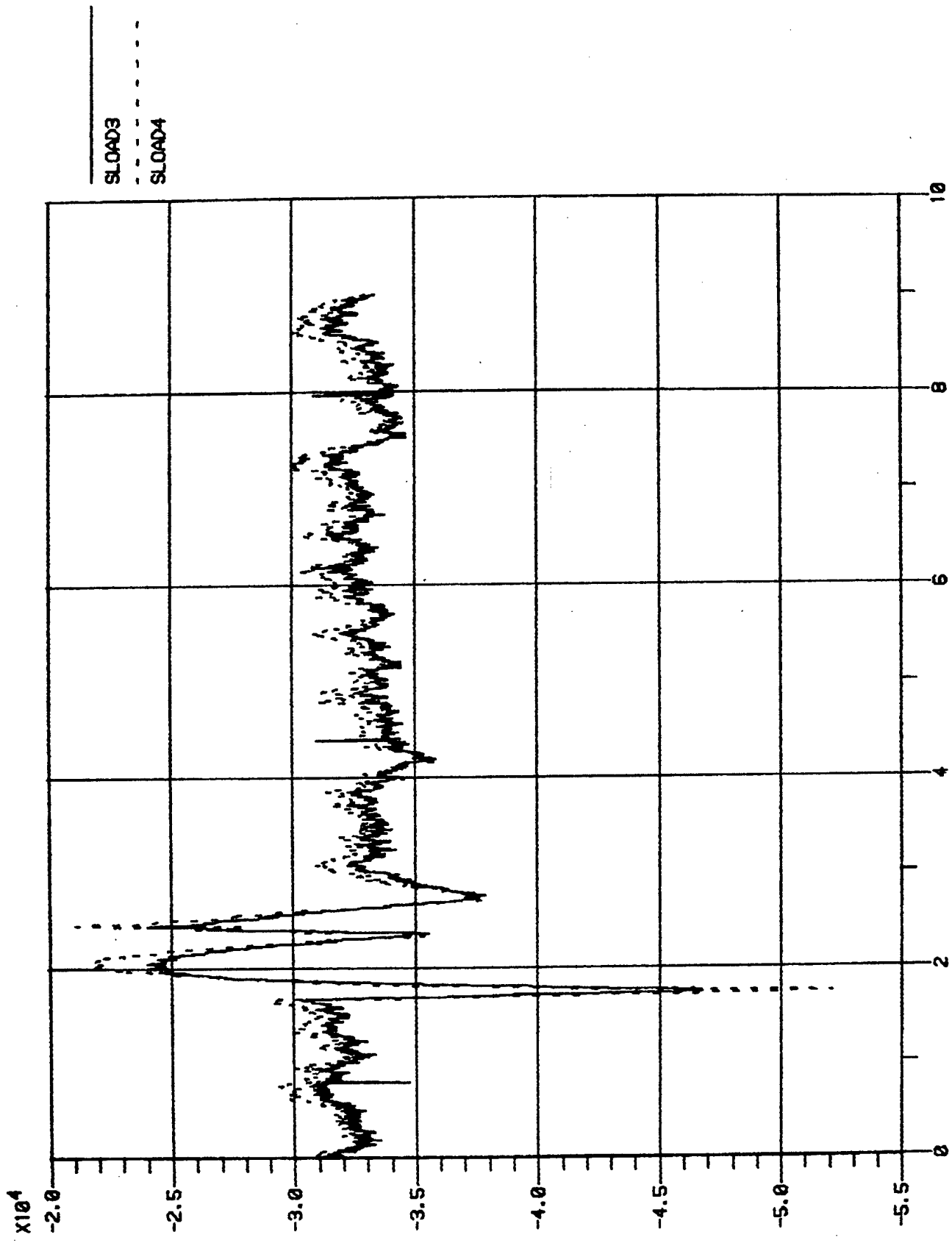

Figure 38 Time History of SLOAD3 and SLOAD4

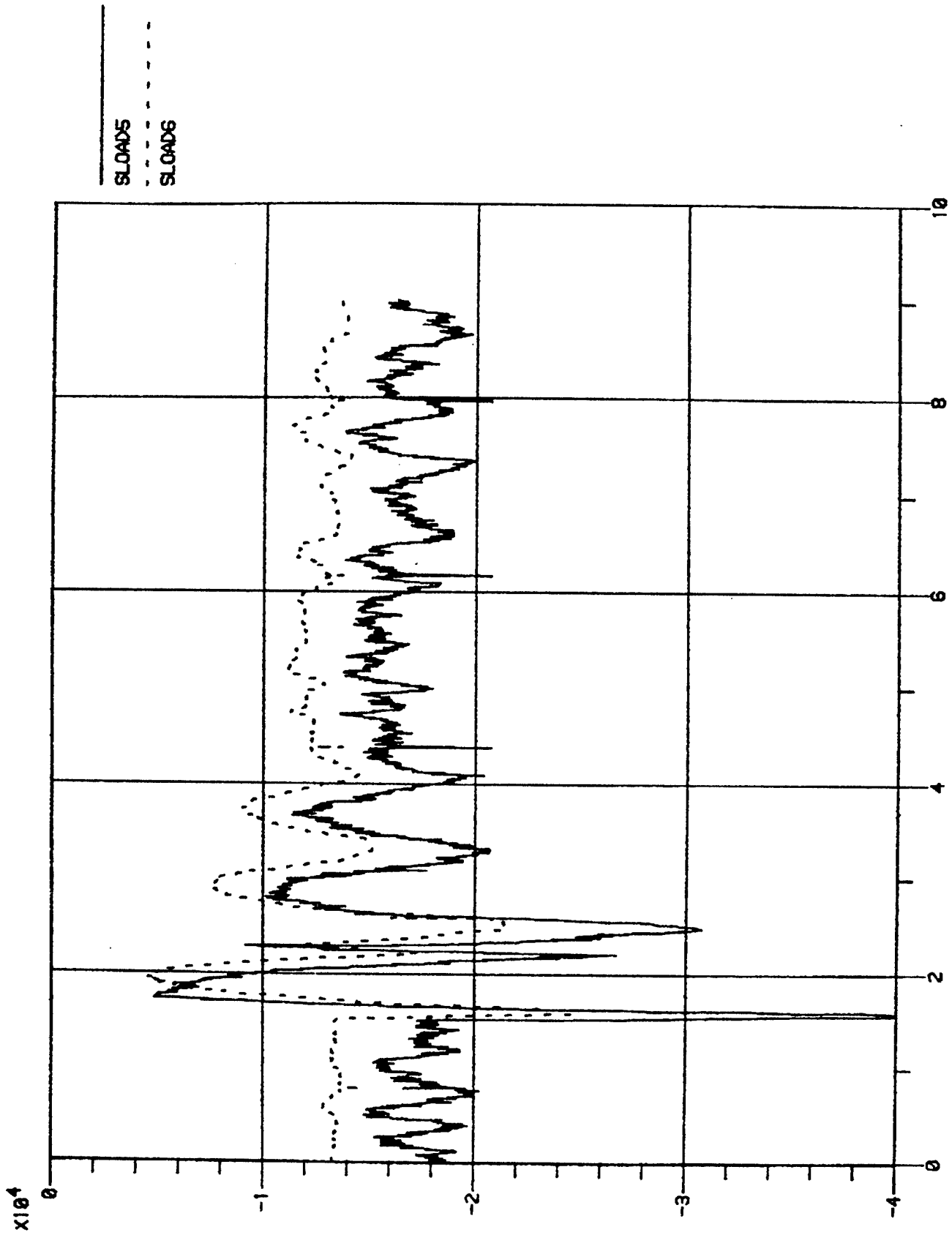

Figure 39 Time History of SLOAD5 and SLOAD6

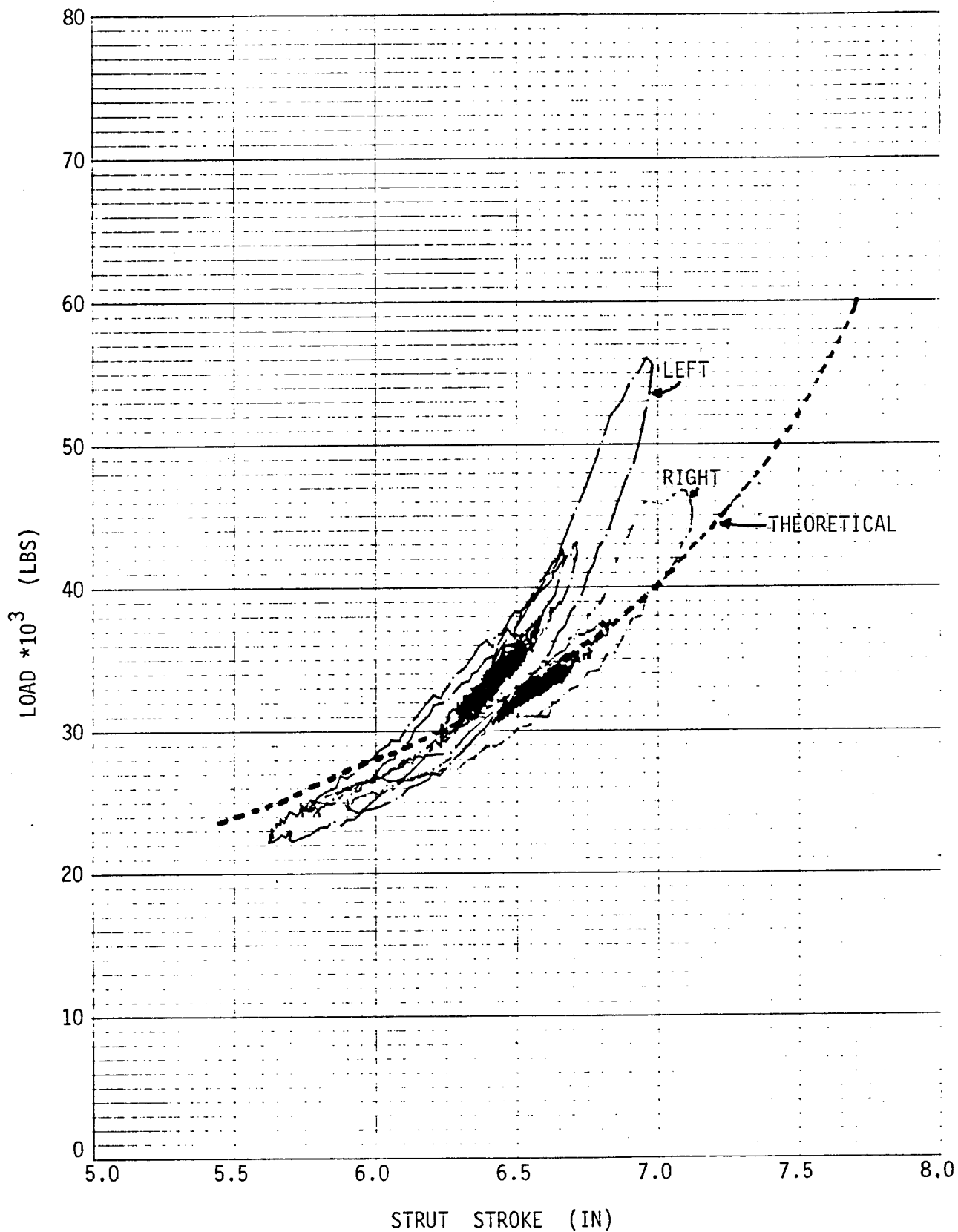

Figure 40 Load versus Stroke Curve for Main Landing Gear Struts

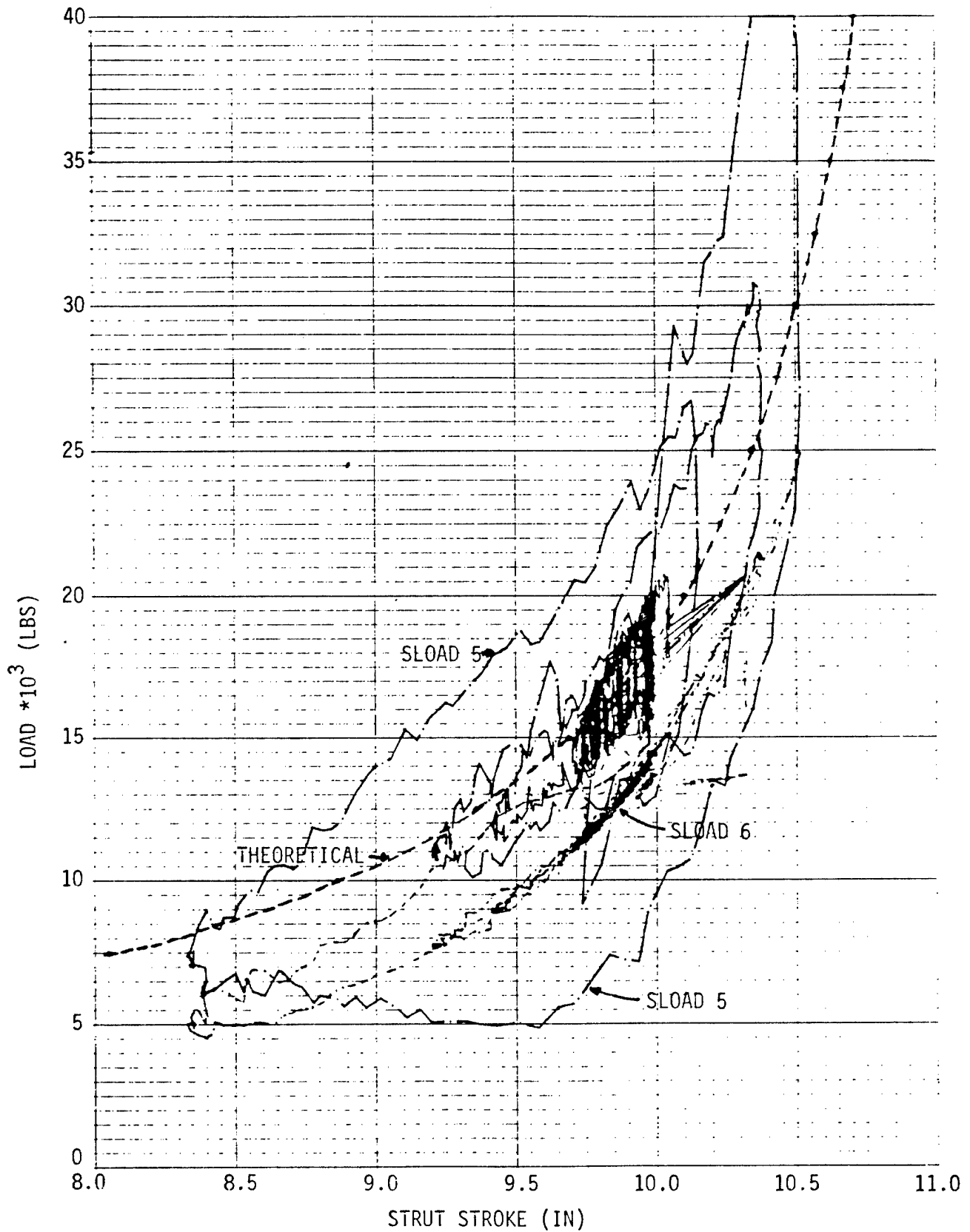
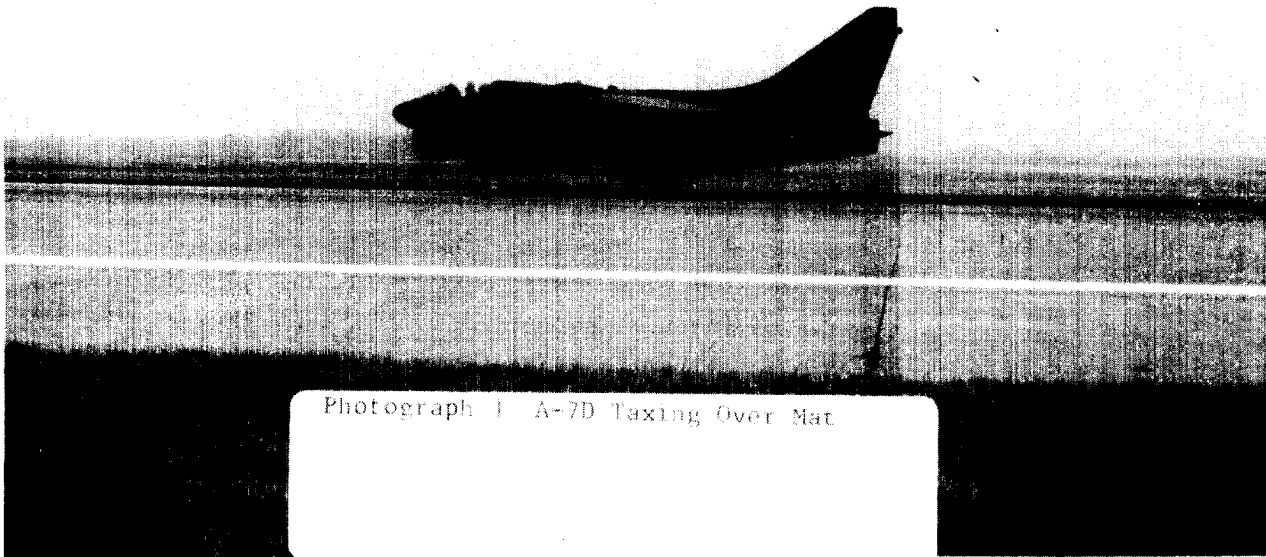
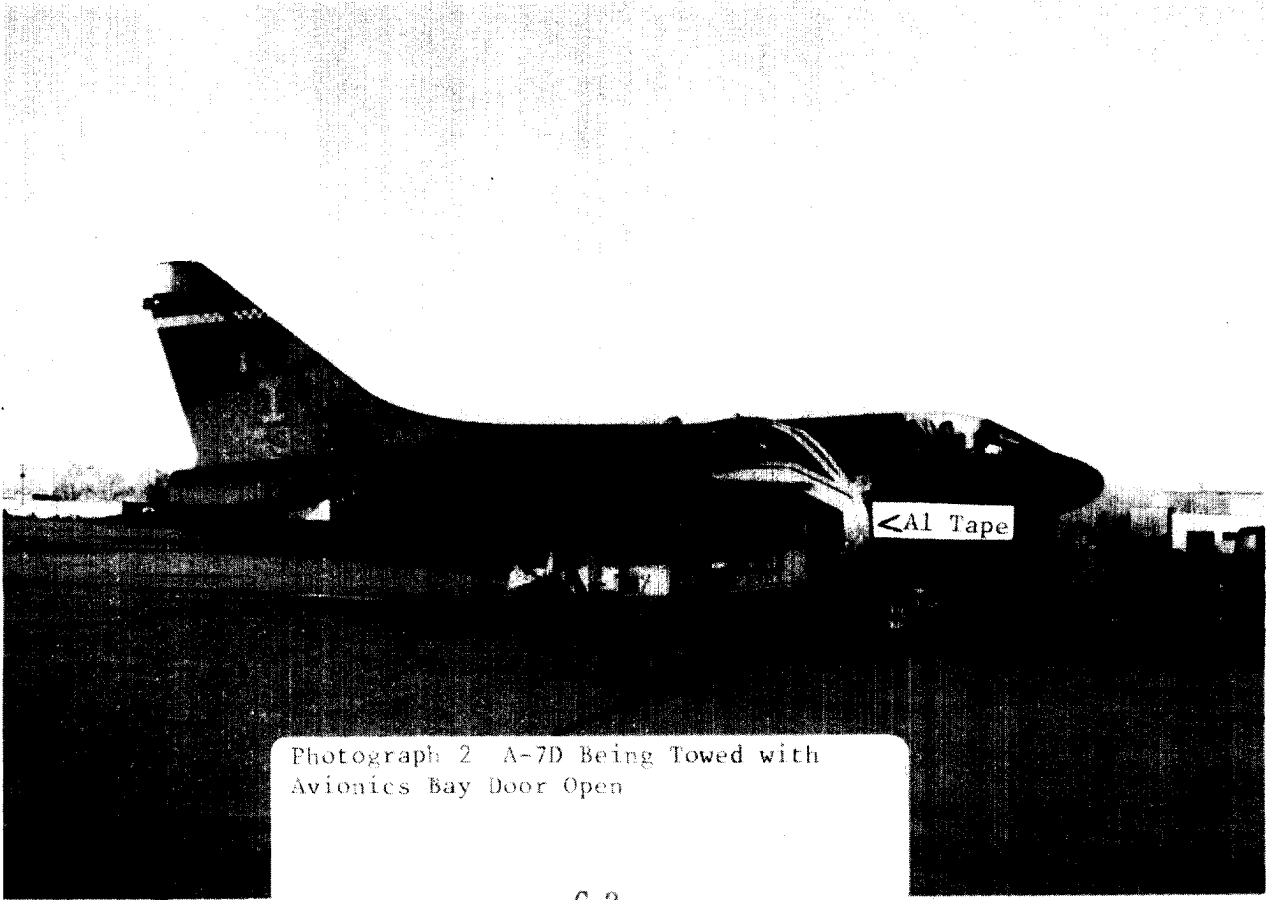

Figure 41 Load versus Stroke Curve for Nose Landing Gear Strut

APPENDIX C  
PHOTOGRAPHS



Photograph 1 A-7D Taxiing Over Mat



Photograph 2 A-7D Being Towed with Avionics Bay Door Open

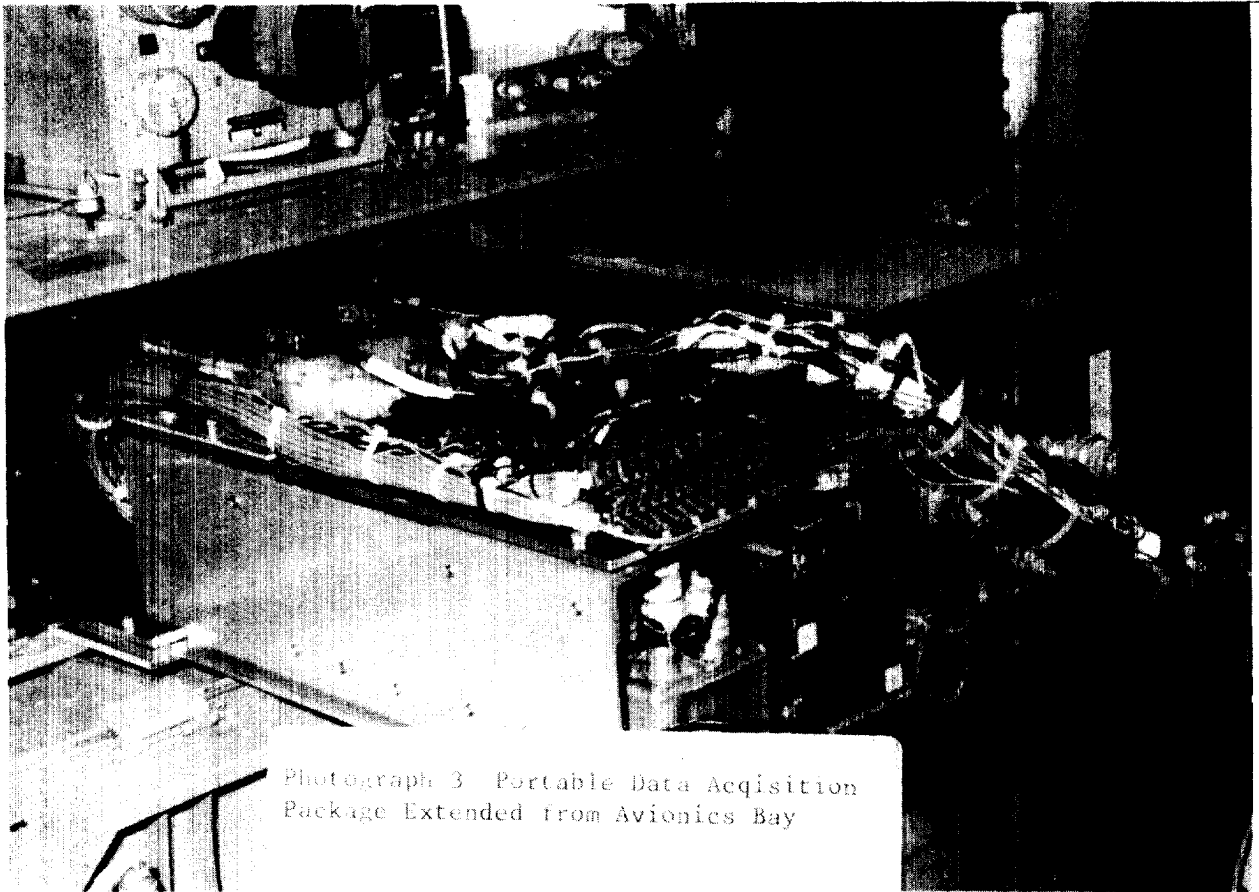

Photograph 3 Portable Data Acquisition  
Package Extended from Avionics Bay

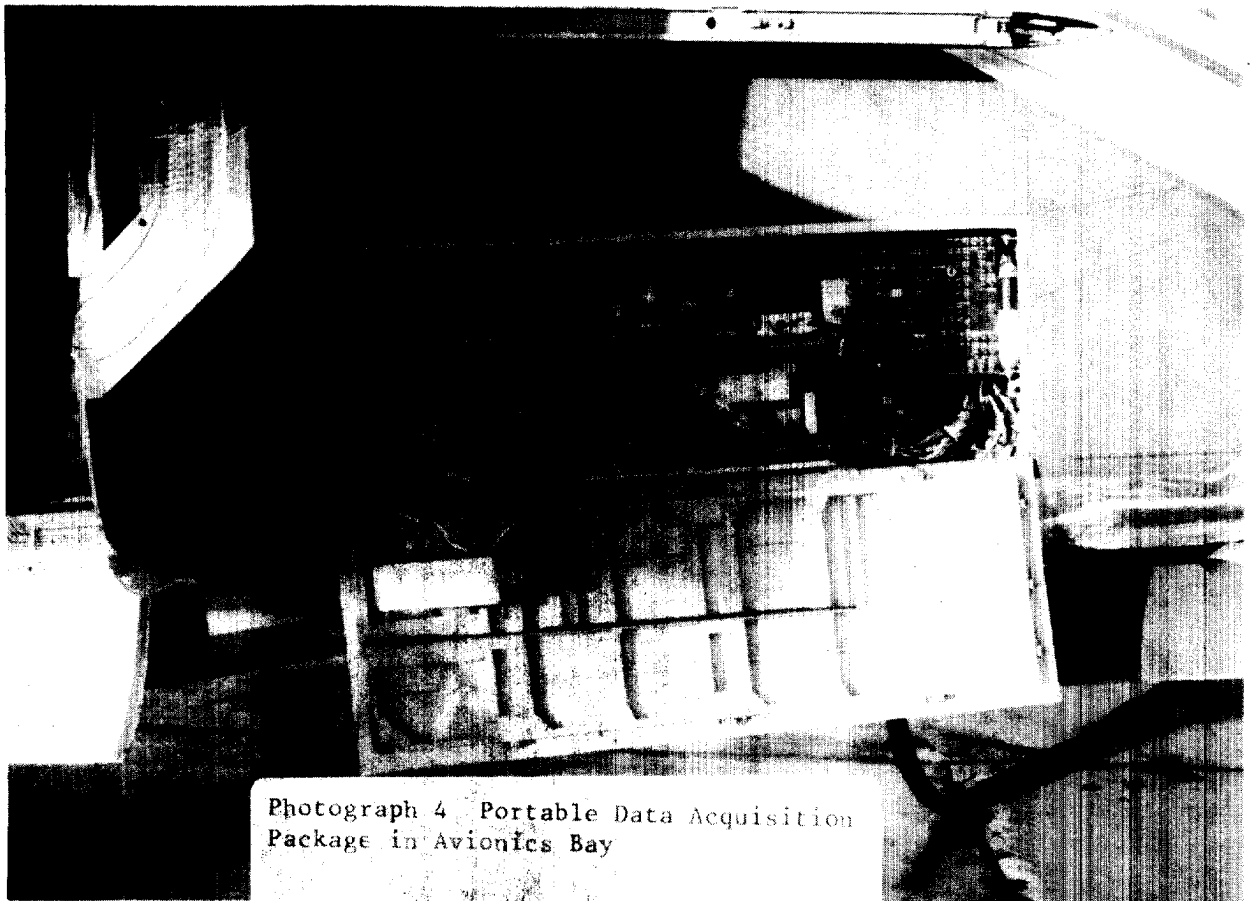

Photograph 4 Portable Data Acquisition  
Package in Avionics Bay

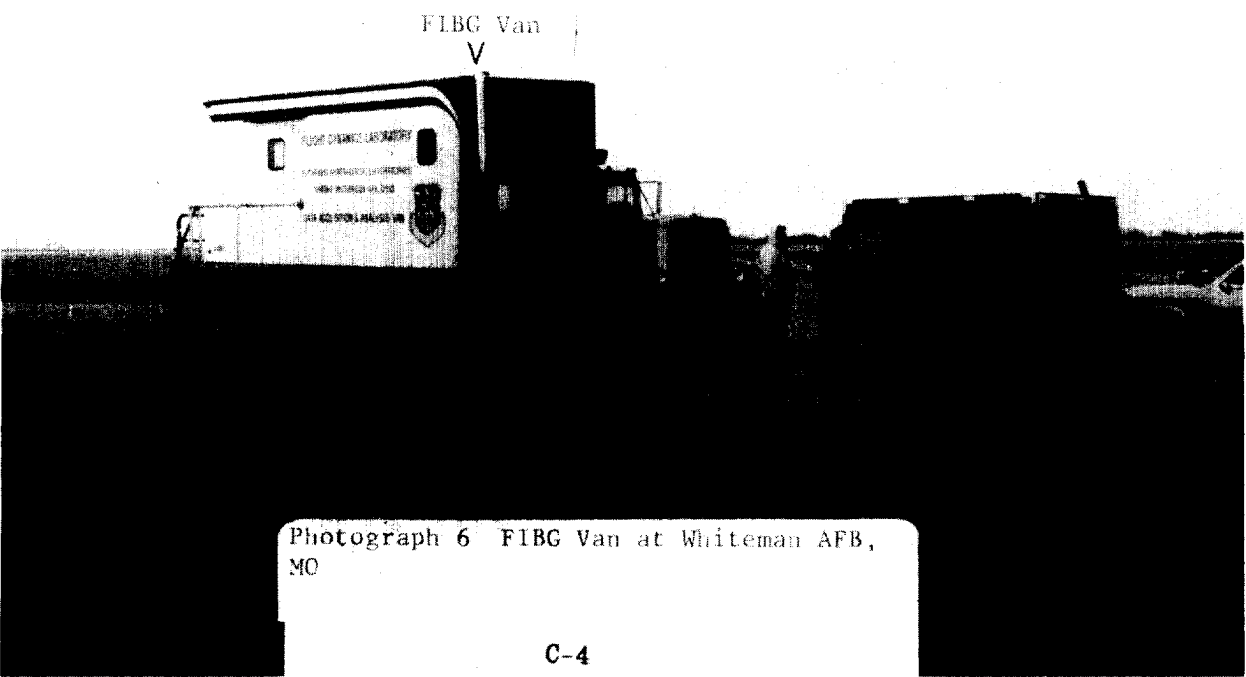
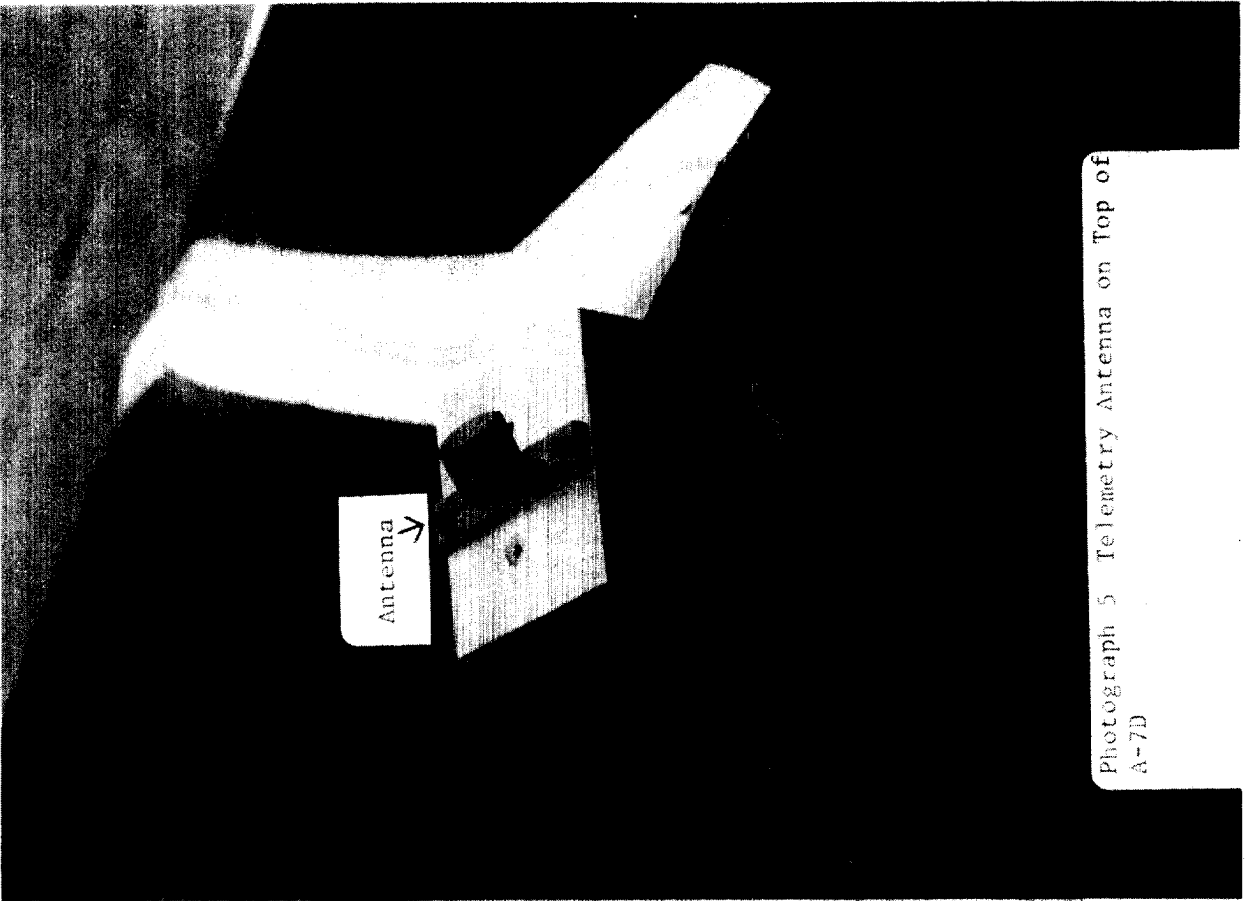

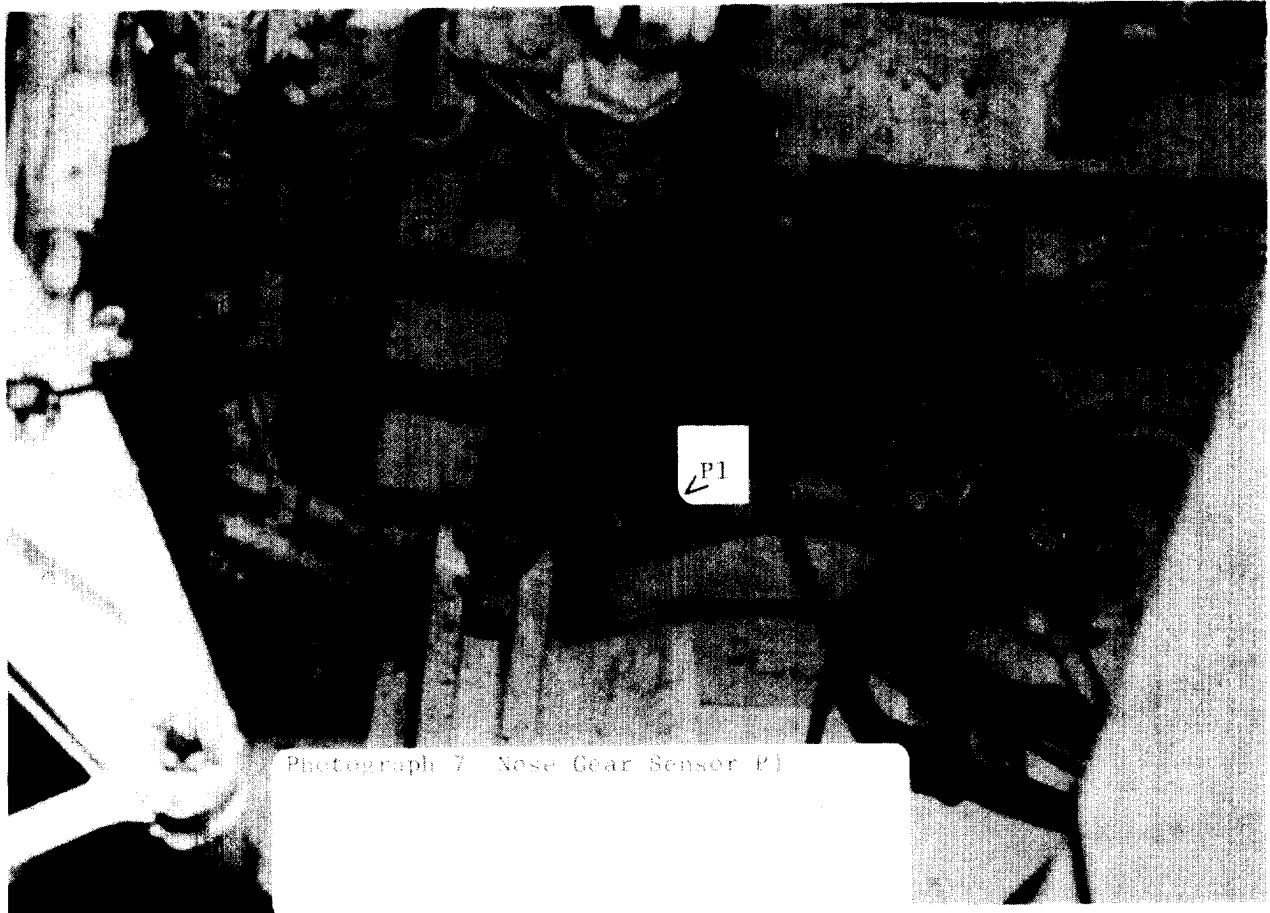

Photograph 7 Nose Gear Sensor P1

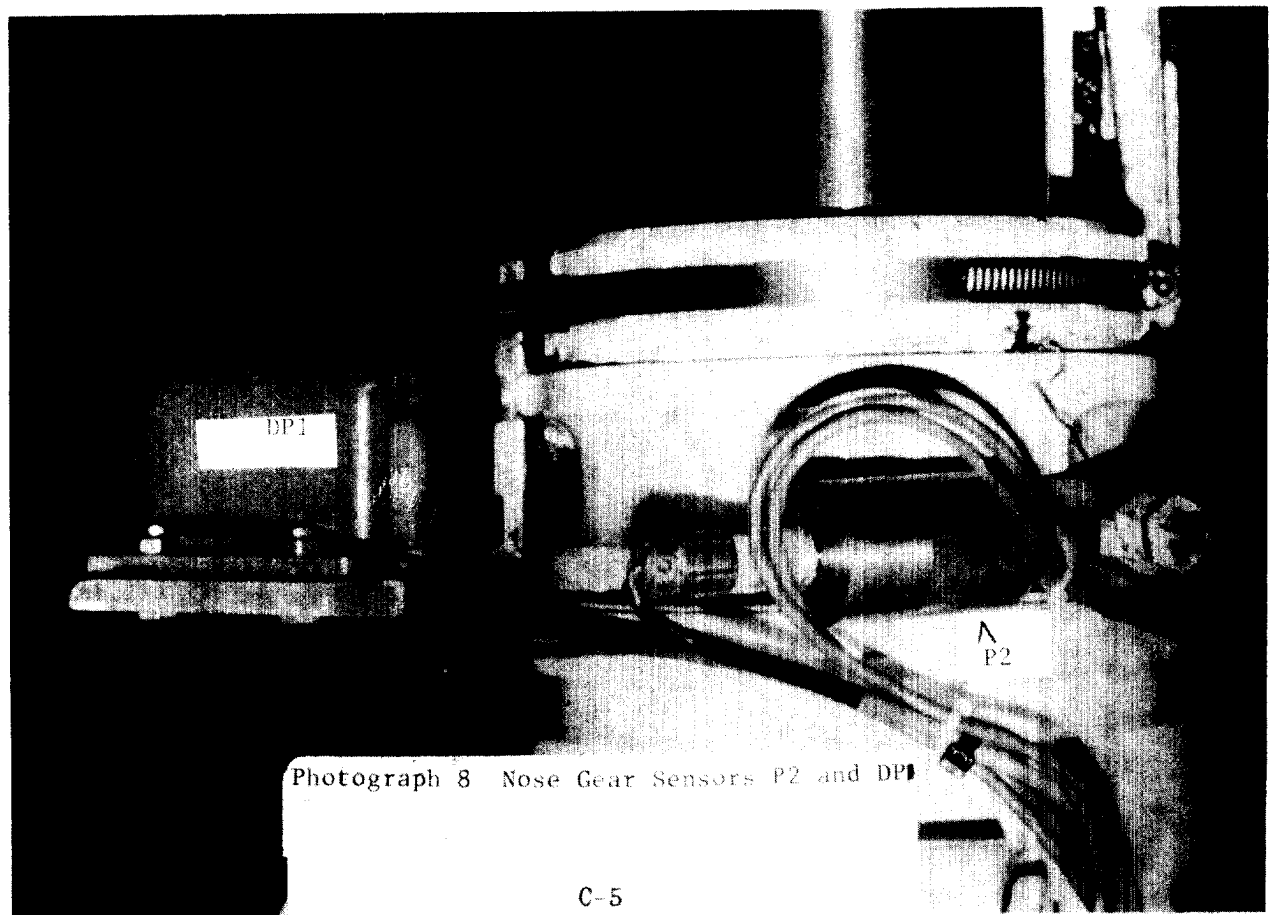

Photograph 8 Nose Gear Sensors P2 and DP1

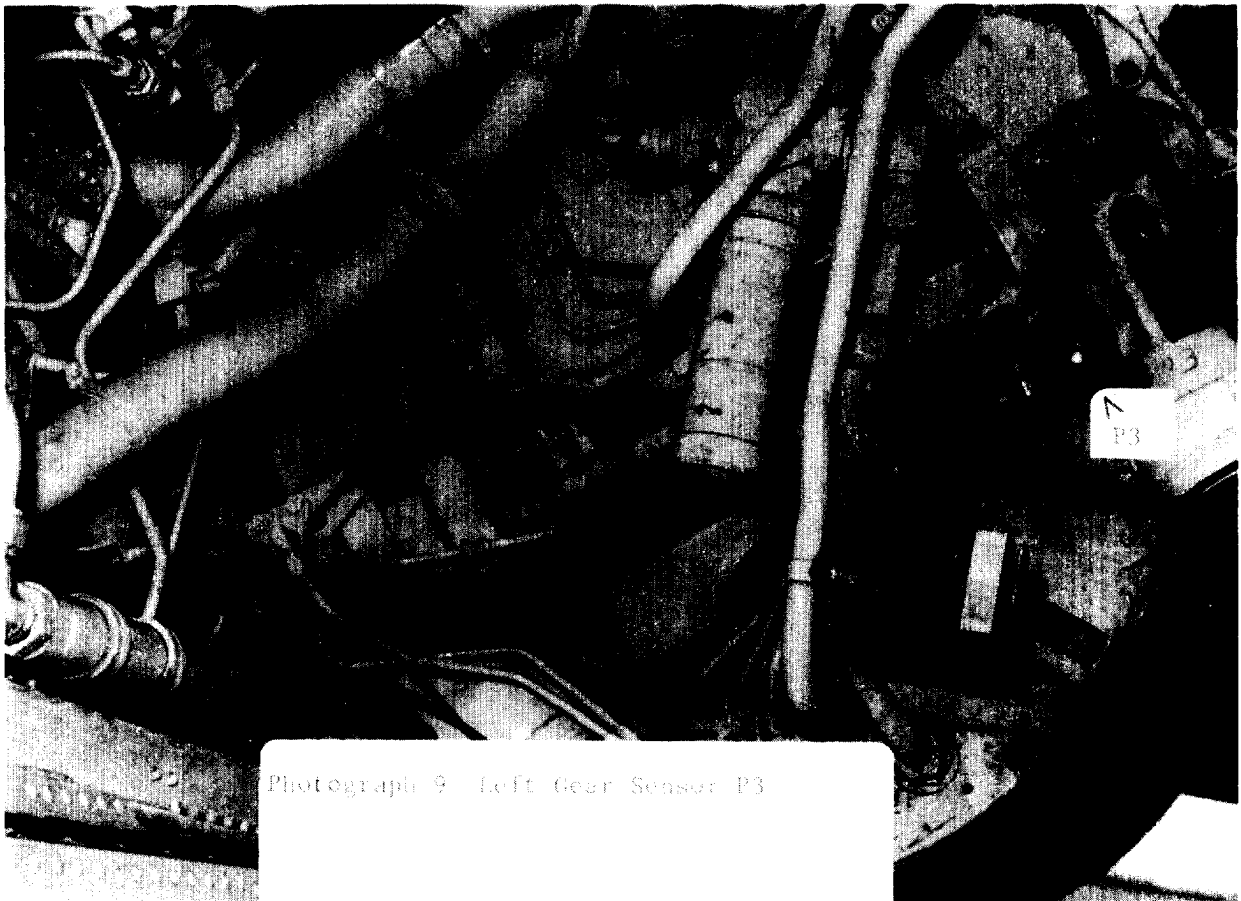

Photograph 9 Left Gear Sensor P3

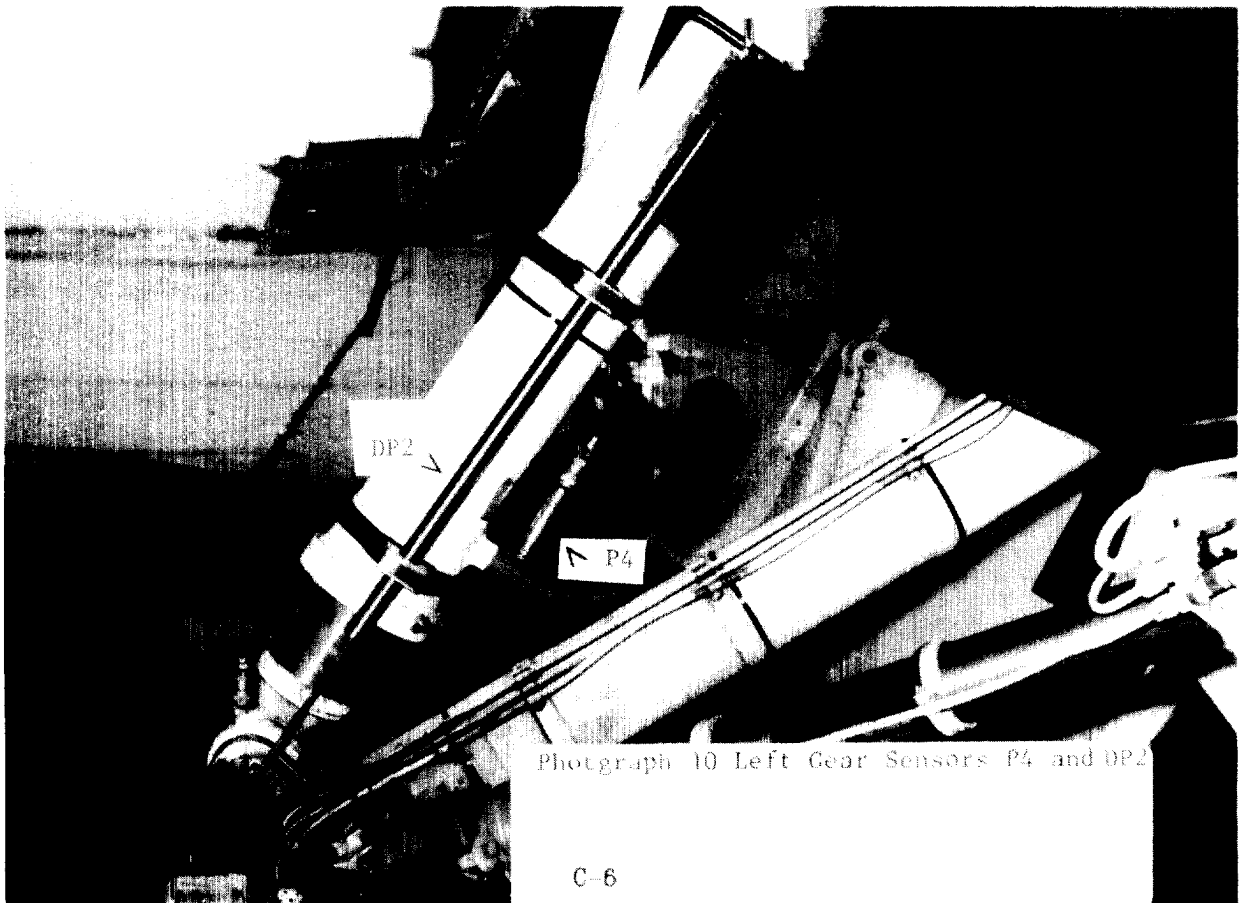

Photograph 10 Left Gear Sensors P4 and DP2

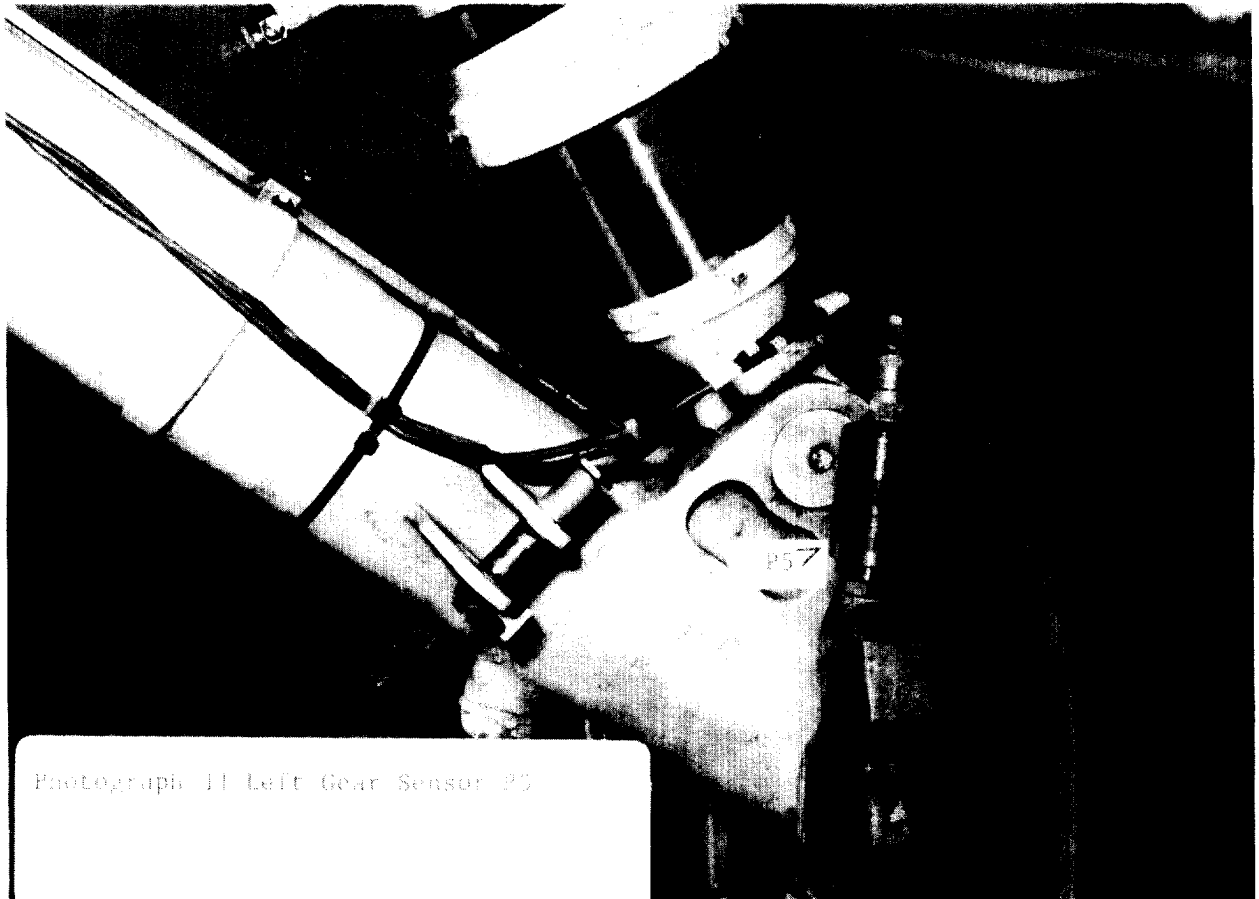

Photograph 11 Left Gear Sensor P57

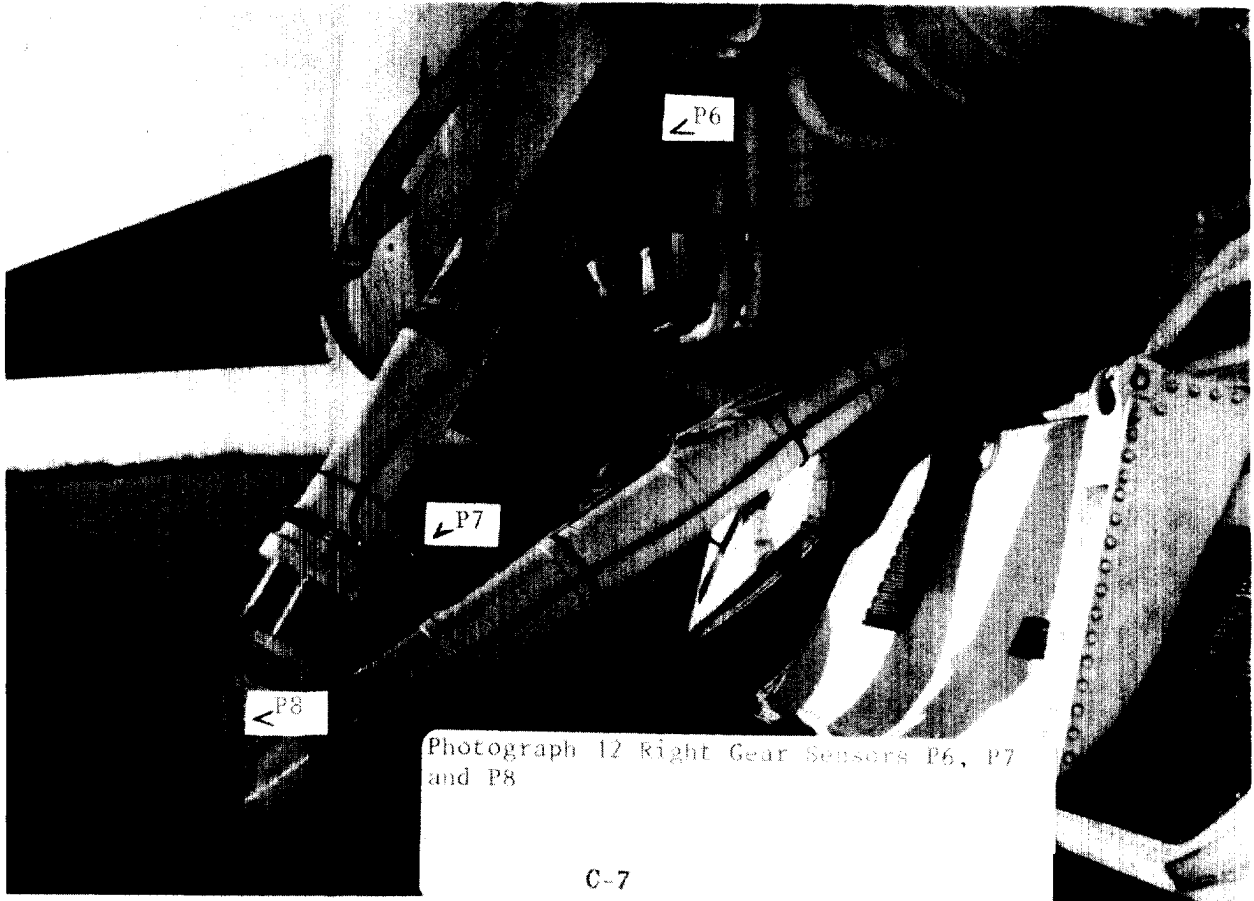

Photograph 12 Right Gear Sensors P6, P7 and P8

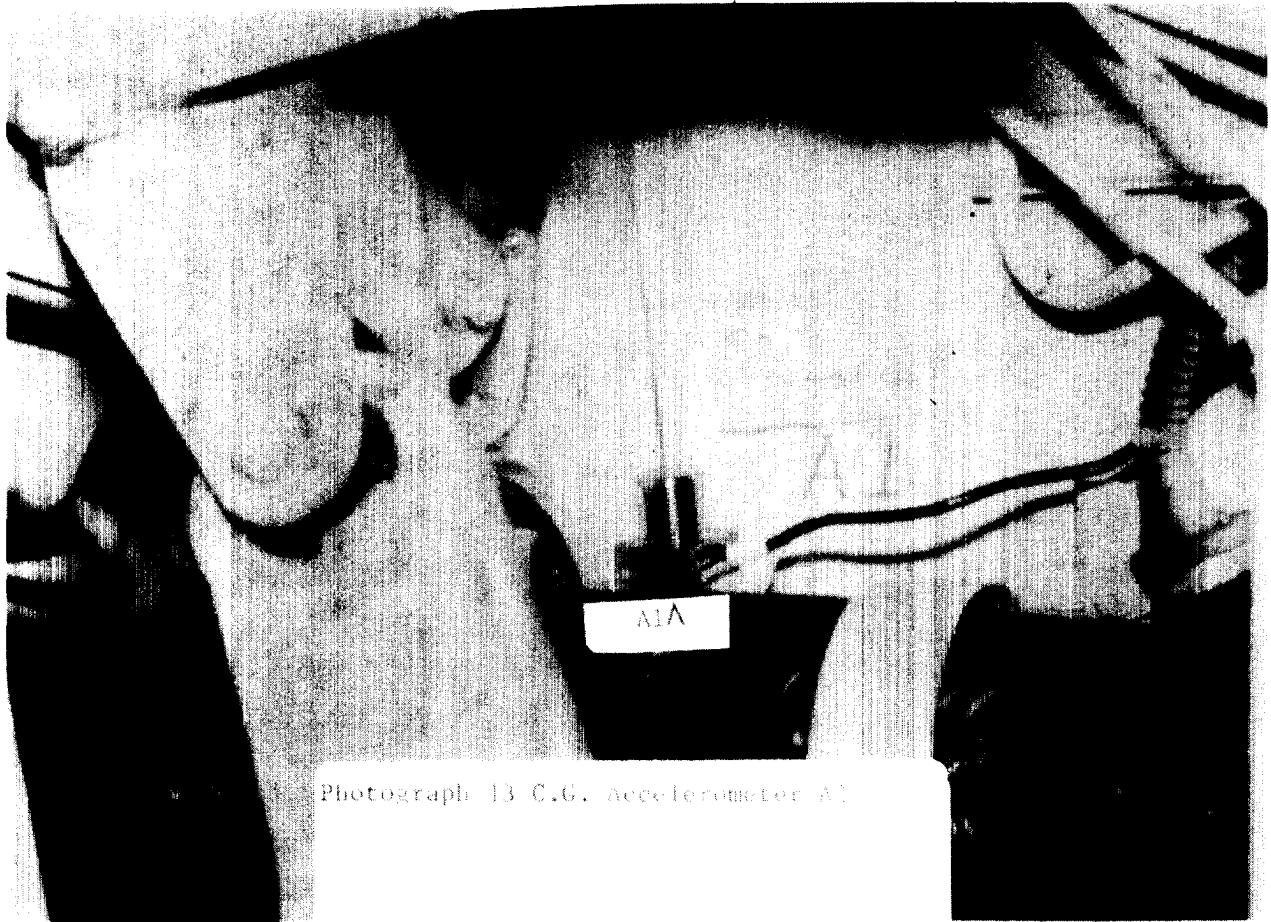

Photograph 13 C.G. Accelerometer A1

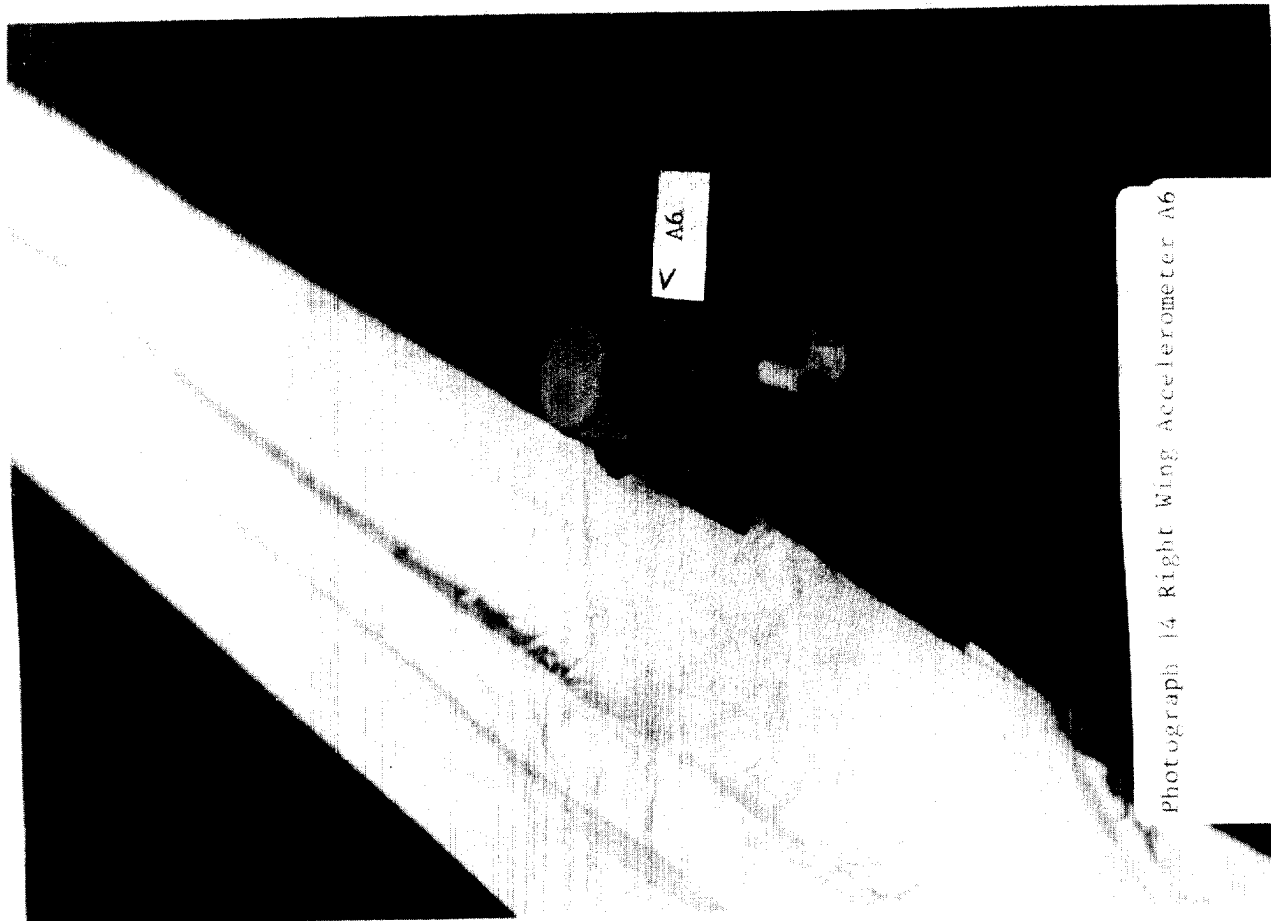

Photograph 14 Right Wing Accelerometer A6

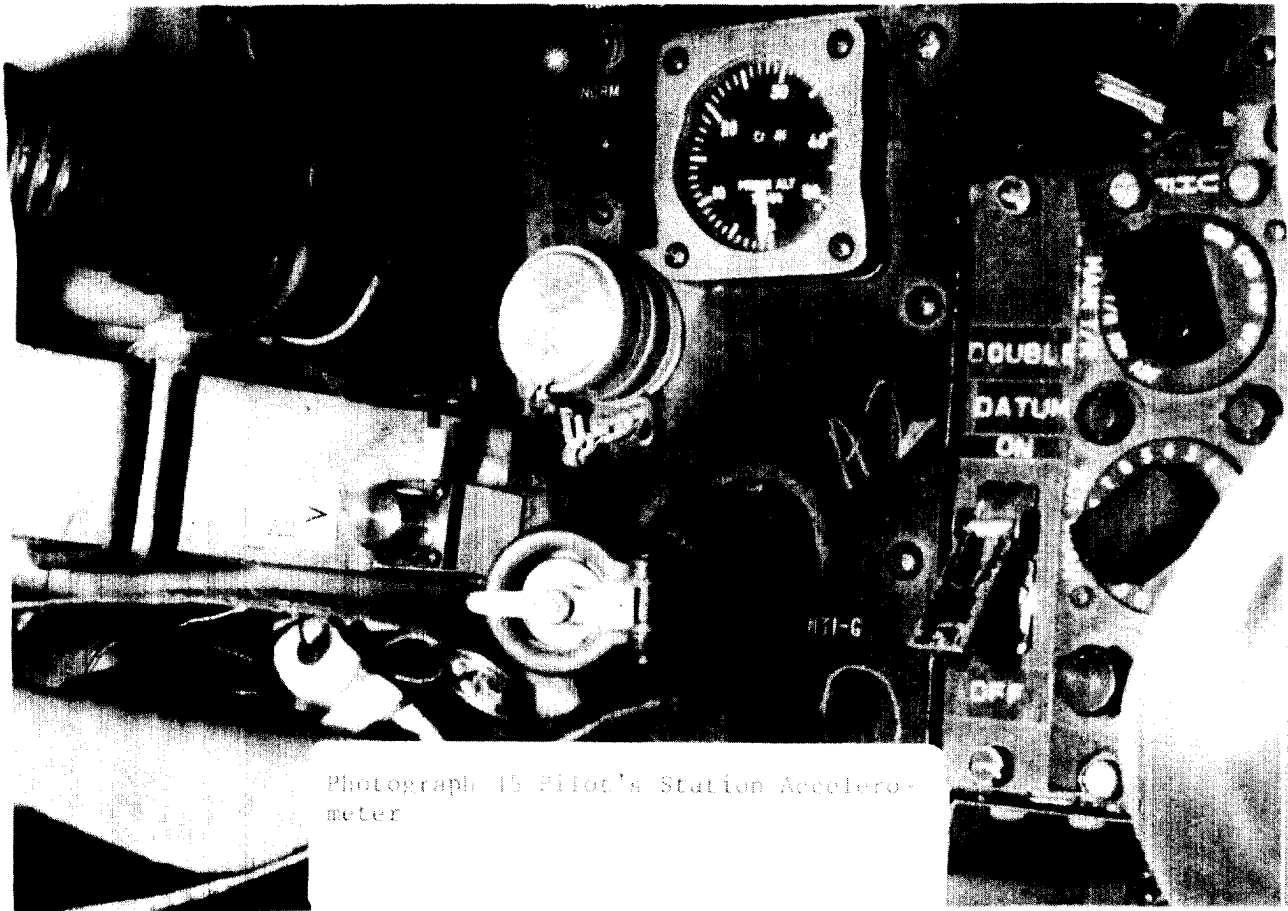

Photograph 15 Pilot's Station Accelerometer

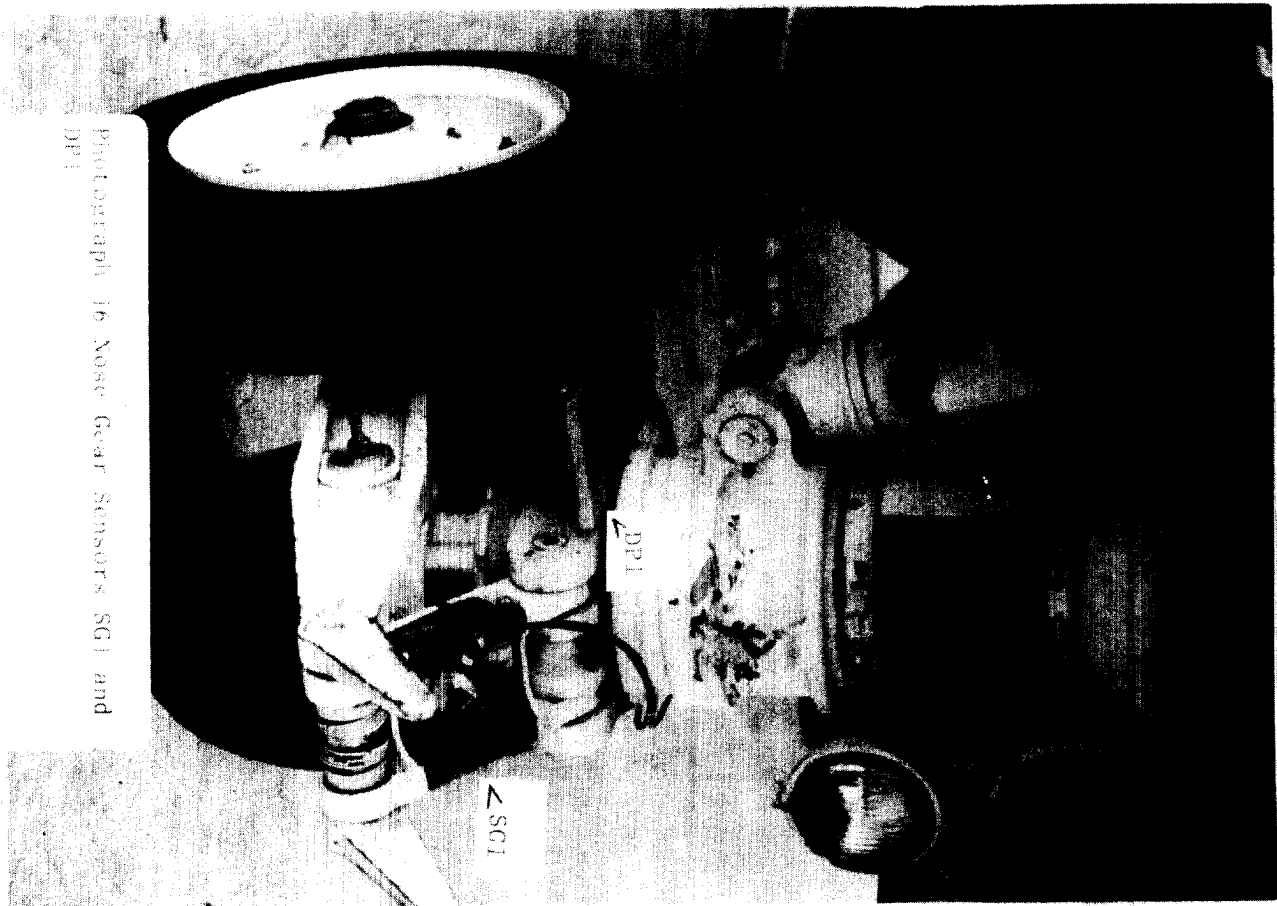

Photograph 16 Nose Gear Sensors SGI and DPI

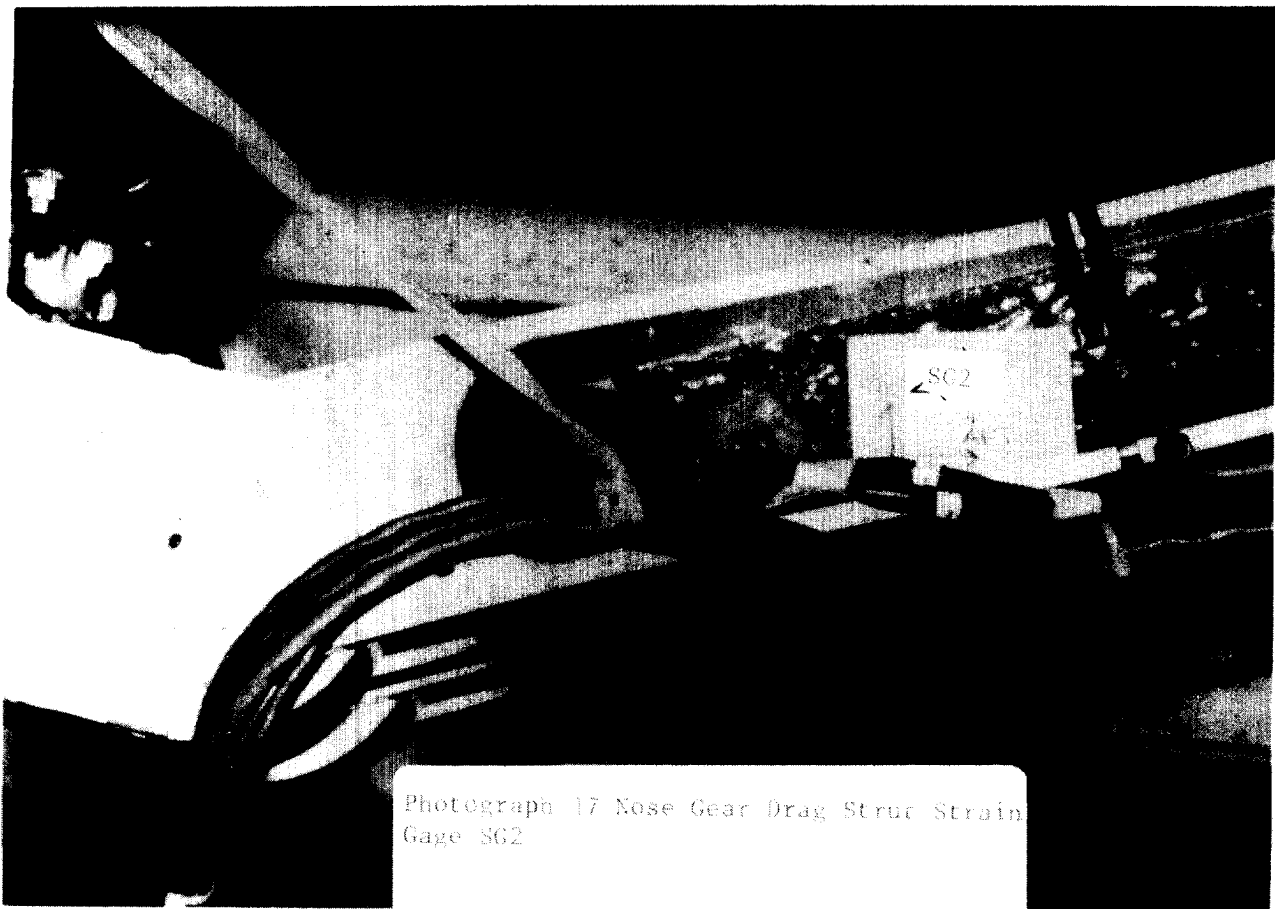

Photograph 17 Nose Gear Drag Strut Strain Gage SG2

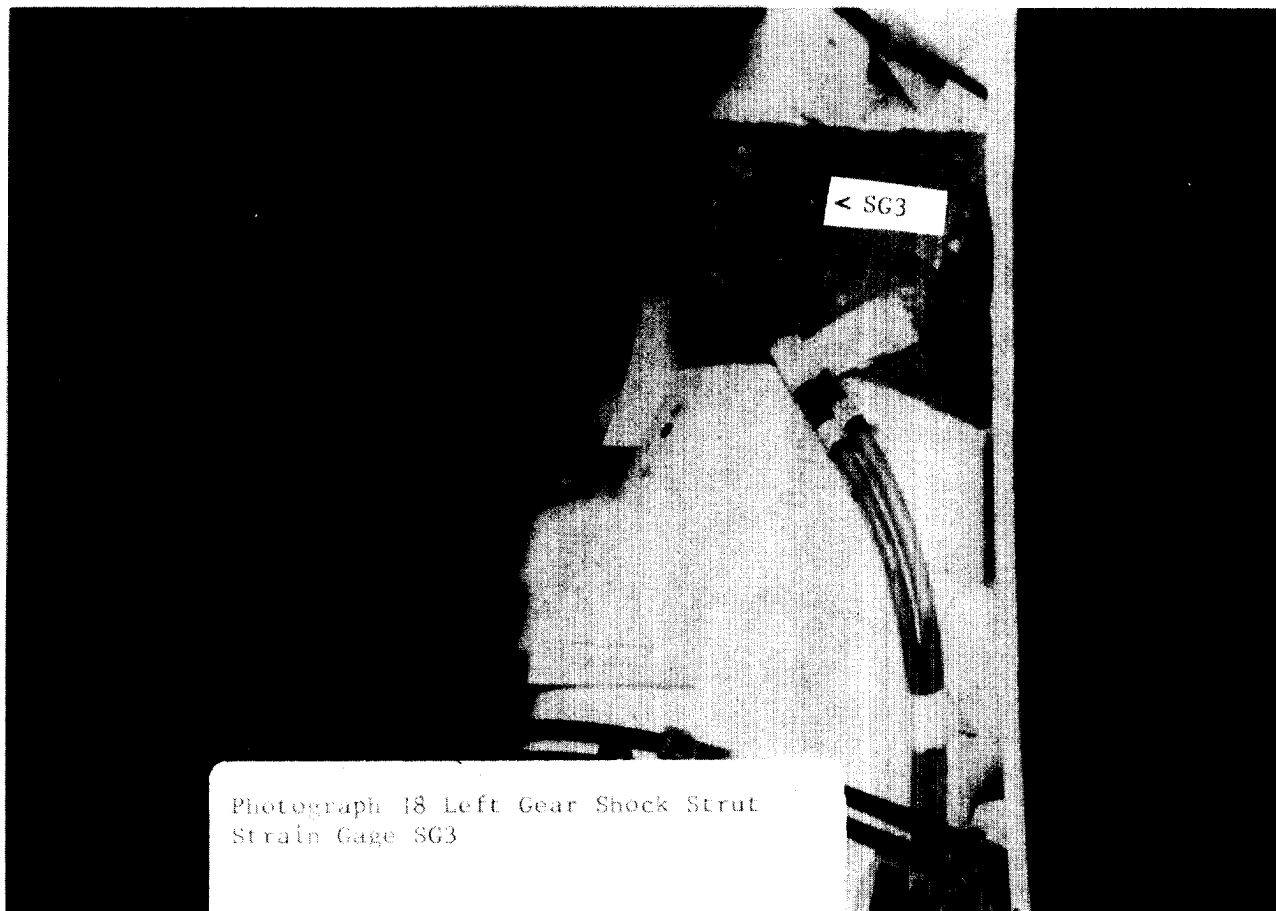

Photograph 18 Left Gear Shock Strut Strain Gage SG3

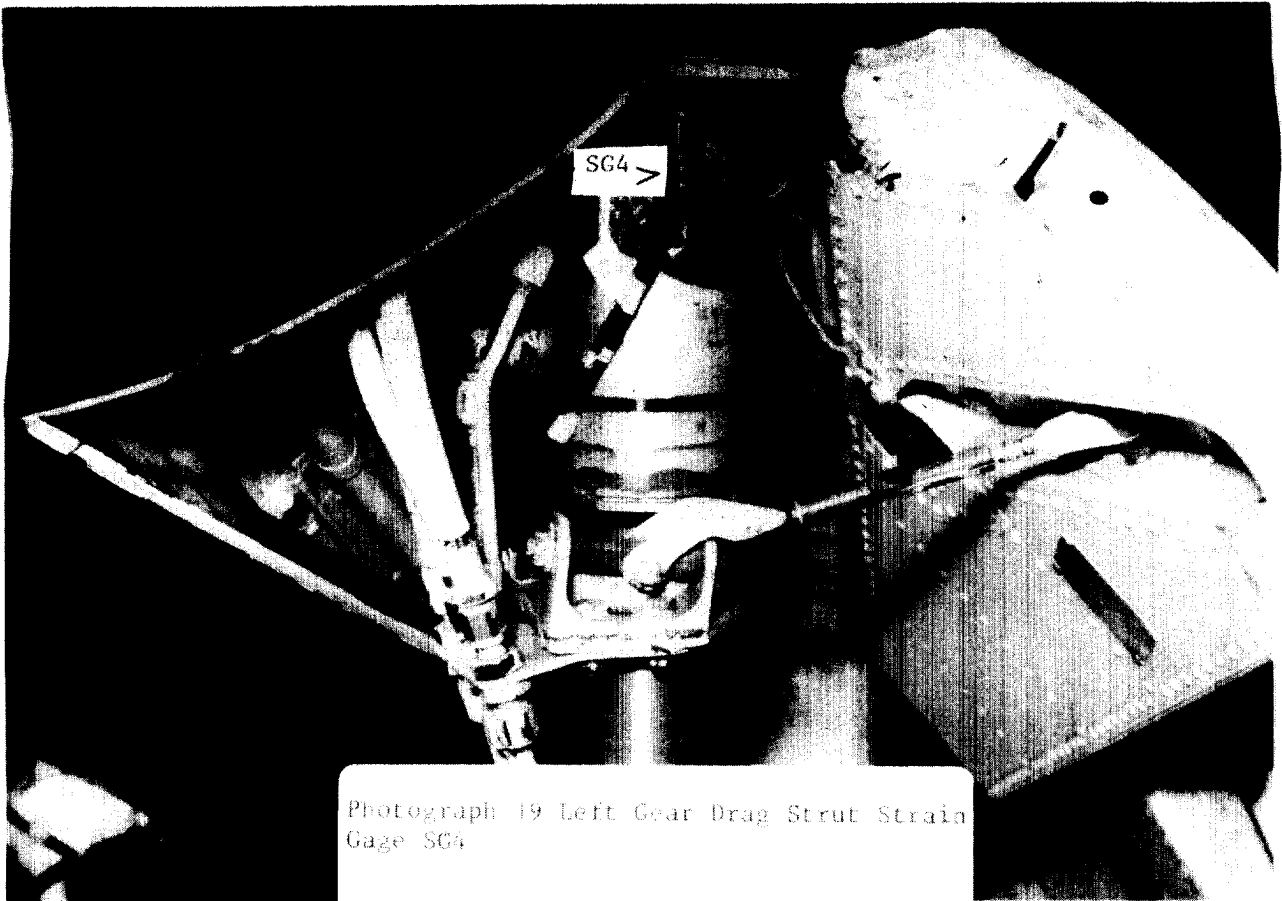

Photograph 19 Left Gear Drag Strut Strain Gage SG4

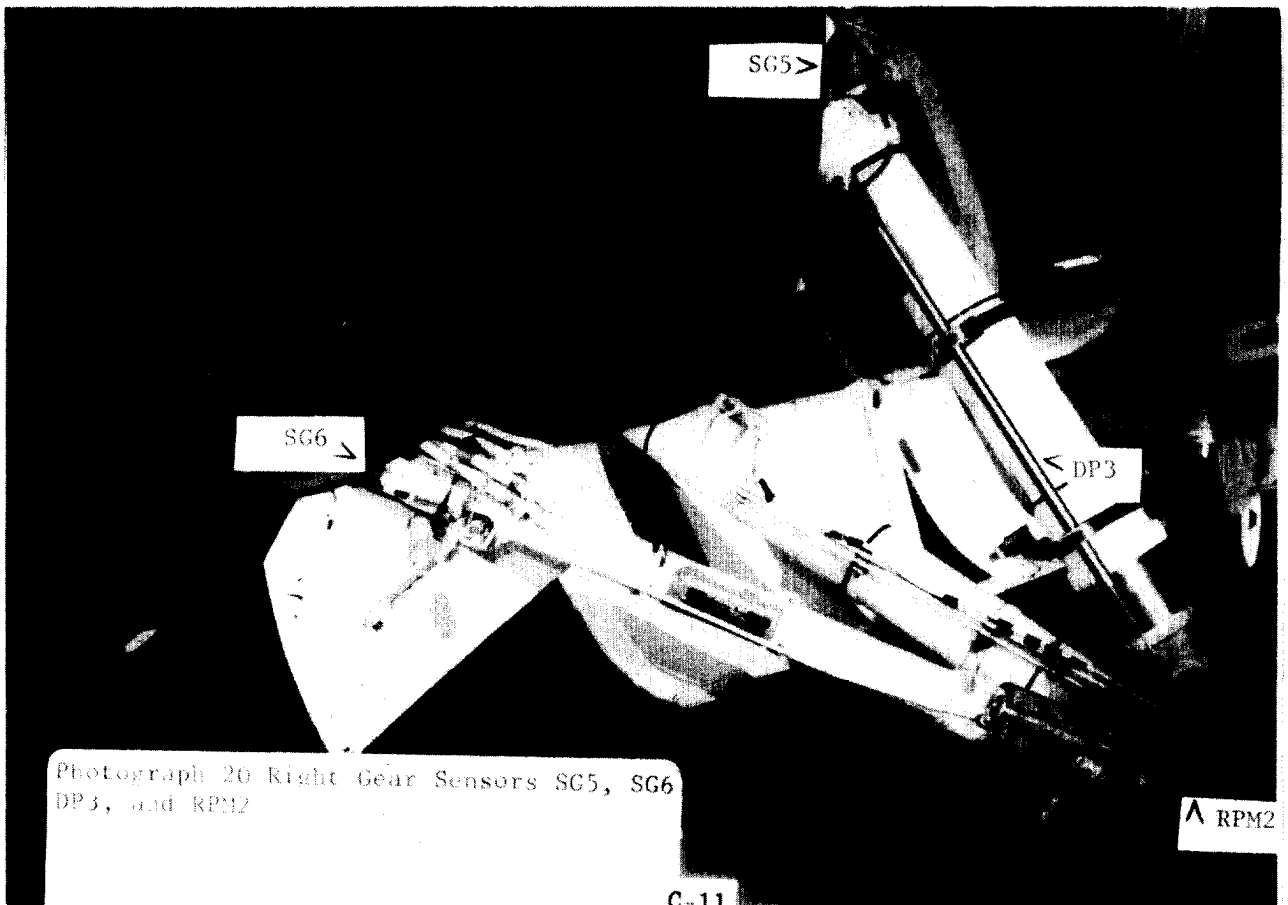

Photograph 20 Right Gear Sensors SG5, SG6 DP3, and RPM2



Photograph 21 Left Gear Aircraft Proximity  
Sensor RPM1

APPENDIX D  
RUNWAY SURVEY LOG



STA	BOUNCE	AM2	MATTING SURVEY
	BS	HI	ELEV RMKS
	5.83	838.57	832.54 STA 5+00 BL
1			5.71 832.66 STA 4+00 BL
2			5.70 832.67 4+02
3			5.71 832.66 4+04
4			5.71 832.66 4+06
5			5.71 832.66 4+08
6			5.71 832.66 4+10
7			5.71 832.66 4+12
8			5.72 832.65 4+14
9			5.67 832.70 TCE CF RAMP+15
10			5.64 832.73 4+16
11			5.58 832.79 4+18
12			5.56 832.81 TCE CF RAMP+19

Encl. (1) to 2-51220/5L-36

BS	HI	FS	ELEV	RKMS
14		5.51	832.96	4+20
15		5.44	832.93	4+22
16		5.43	832.94	4+24
17		5.42	832.95	4+26
18		5.42	832.95	4+28
19		5.42	832.95	4+30
20		5.42	832.95	4+32
21		5.42	832.95	4+34
22		5.42	832.95	4+36
23		5.44	832.93	4+38
24		5.45	832.92	4+40
25		5.45	832.92	4+42
		5.45	832.92	4+44

D-  
W

ENCLOSURE  
-6

Encl. (1) to 2-51220/5L-365

TA	BS	HI	FS	ELEV	RvKS
27			5.45	832.92	4+46
28			5.45	832.92	4+48
29			5.46	832.91	4+50
30			5.46	832.91	4+52
31			5.47	832.90	4+54
32			5.48	832.89	4+56
33			5.48	832.89	4+58
34			5.48	832.89	4+60
35			5.49	832.88	4+62
36			5.50	832.87	4+64
37			5.50	832.87	4+66
38			5.50	832.87	4+68
			5.51	832.86	4+70

(1) to 2-51220/5L-365

Encl.

STA	B.S	HI	FS	ELEV	MARKS
39			5.51	832.86	4+72
40			5.51	832.86	4+74
41			5.51	832.86	4+76
42			5.52	832.87	4+78
43			5.52	832.87	4+80
44			5.52	832.87	4+82
45			5.52	832.87	4+84
46			5.53	832.86	4+86
47			5.58	832.79	4+88
48			5.63	832.74	TOP OF RAMP 4+89
49			5.67	832.70	4+90
50			5.74	832.63	4+92
51			5.78	832.59	TOP OF RAMP 4+93

Encl. (1) to 2-51220/5L-365

STA	BS	HI	FS	ELEV	RMS
52			5.82	832.55	4+94
53			5.83	832.54	4+96
54			5.84	832.53	4+98
55			5.84	832.53	5+00
56			5.86	832.51	5+02
57			5.86	832.51	5+64
58			5.86	832.51	5+66
59			5.86	832.51	5+68
60			5.87	832.50	5+70
61			5.88	832.49	5+72
62			5.87	832.50	5+74
63			5.82	832.55	TRAMP 5+75
64			5.78	832.59	5+76

Encl. (1) to 2-51220/5L-365

STA	BS	HI	FS	ELEV	RMS
65			5.71	832.66	HEAD OF RAMP 5+78
66			5.64	832.73	5+80
67			5.60	832.77	5+82
68			5.60	832.77	5+84
69			5.60	832.77	5+86
70			5.60	832.77	5+88
71			5.61	832.76	5+90
72			5.61	832.76	5+92
73			5.61	832.76	5+94
74			5.61	832.76	5+96
75			5.63	832.74	5+98
76			5.63	832.74	6+00
77			5.62	832.75	6+02

Encl. (1) to 2-51220/5L-365

STA	BS	HI	FS	ELEV	RMKS
78			5.63	832.74	6+04
79			5.63	832.74	6+06
80			5.63	832.74	6+08
81	4.97	837.53	5.83	832.56	6+10
82			4.76	832.77	6+12
83			4.76	832.77	6+14
84			4.76	832.77	6+16
85			4.77	832.76	6+18
86			4.77	832.76	6+20
87			4.77	832.76	6+22
88			4.77	832.76	6+24
89			4.77	832.76	6+26
90			4.78	832.75	6+28

(1) to 2-51220/5L-365

Enc]

STA	BS	HI	FS	ELEV	RMKS
91			4.80	832.73	6+30
92			4.80	832.73	6+32
93			4.81	832.72	6+34
94			4.81	832.72	6+36
95			4.82	832.71	6+38
96			4.83	832.70	6+40
97			4.83	832.70	6+42
98			4.83	832.70	6+44
99			4.83	832.70	6+46
100			4.86	832.67	6+48
101			4.93	832.60	HEAD OF RAMP 6+48
102			5.00	832.53	6+50
103			5.04	832.49	TDC OF RAMP 6+52

(1) to 2-51220/5L-365

Encl

STA  
104

BS

HI  
837.53

FS  
5.11

ELEV  
832.42

RMKS  
6+54

105

5.11

832.42

6+56

106

5.13

832.40

6+58

107

5.14

832.39

6+60

108

5.13

832.40

6+62

109

4.97

832.50

6+64

D10