

# APPLICATION OF PHOTOSYNTHESIS TO ARTIFICIAL SIGHT

E. Greenbaum<sup>1,2</sup>, M. S. Humayun<sup>3</sup>, T. Kuritz<sup>1,2</sup>, J. W. Lee<sup>1</sup>, C. A. Sanders<sup>1</sup>, B. Bruce<sup>2</sup>, J. Millsaps<sup>2</sup>, I. Lee<sup>4</sup>

<sup>1</sup>Chemical Technology Division, Oak Ridge National Laboratory, Oak Ridge, TN, USA

<sup>2</sup>Center for Environmental Biotechnology, <sup>4</sup>Dept. Electrical Engineering, University of Tennessee, Knoxville, TN, USA

<sup>3</sup>The Wilmer Eye Institute, Johns Hopkins University Medical School, Baltimore, MD, USA

**Abstract**-Using the technique of Kelvin force microscopy, we have performed the first measurements of photovoltages from *single* photosynthetic reaction centers [1]. The measured values, typically 1 V or more, are sufficiently large to trigger a neural response. The goal of this project is insertion of purified Photosystem I (PSI) reaction centers or other photoactive agents into retinal cells where they will restore photoreceptor function to people who suffer from age-related macular degeneration (AMD) or retinitis pigmentosa (RP), diseases that are the leading causes of blindness world-wide. Although the neural wiring from eye to brain is intact, these patients lack photoreceptor activity. It is the ultimate goal of this proposal to restore photoreceptor activity to these patients using PSI as the optical trigger. In principle, the approach should work. PSI is a robust integral membrane molecular photovoltaic device. Depending on orientation, it can depolarize or hyperpolarize the cell membrane with sufficient voltage to trigger an action potential.

**Keywords** - artificial sight, photosynthesis, reaction centers

## I. INTRODUCTION

This project investigates a new area of multidisciplinary biomedical engineering research that builds on recent advances in nanotechnology of photosynthesis [1,2] and pattern electrical stimulation of the human retina [3] (Fig. 1).

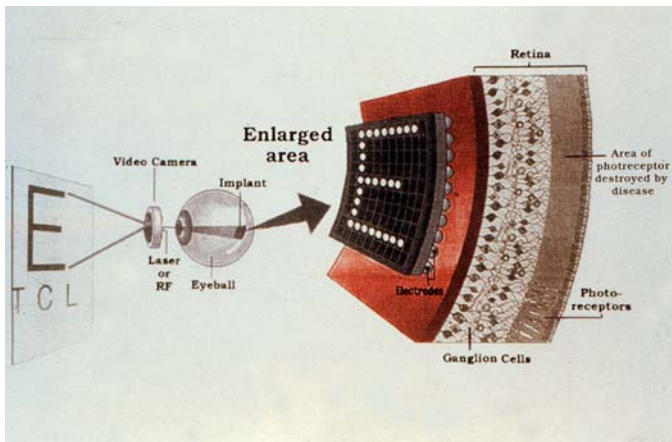

Figure 1 Schematic illustration of electrode stimulation of the human retina

The overall goal of the project is restoration of vision to people who are blind owing to outer retinal/photoreceptor degenerations by insertion of purified Photosystem I (PSI) reaction centers into cell membranes of retinal bipolar or ganglion cells. Whereas Fig. 1 illustrates the use of electrodes as the triggering voltage source, this new approach uses PSI reaction centers (Fig. 2). PSI reaction centers are integral membrane pigment-protein complexes. They are also

nanometer-scale self-contained *portable* molecular photovoltaic devices. Using the technique of Kelvin force probe microscopy, we have measured photovoltages from *single* PSI reaction centers. They span a light-induced electric potential difference of approximately 1 V [1] a value of sufficient magnitude to trigger a neural response. PSI reaction centers self-regenerate via charge recombination, a property that allows them to recycle many times.

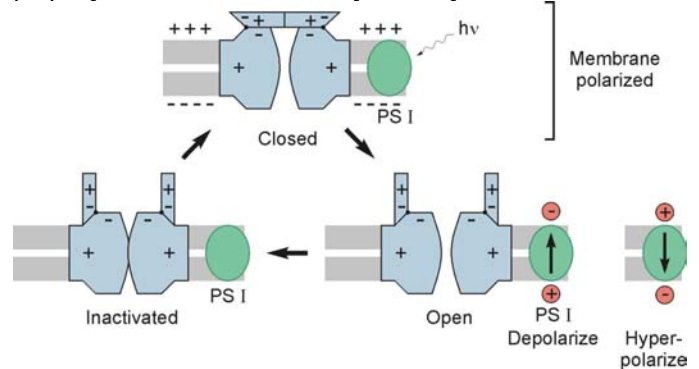

Figure 2 Schematic illustration of a Photosystem I reaction center in proximity to a voltage-gated ion channel.

## II. METHODOLOGY

Hyperpolarization of retinal rod cells occurs when the normally negative interior membrane potential is driven more negative. A single photon absorbed by a dark-adapted rod closes hundreds of cation-specific channels and leads to a hyperpolarization of the membrane [4] which is sensed by the synapse and conveyed to the retinal bipolar and then the retinal ganglion cells of the retina. Since the targeted blind patients lack photoreceptor cells, the specific aim of this project is to properly insert and orient plant membrane pigment-protein complex PSI in a retinal ganglion or bipolar cell membrane, such that photon absorption will trigger an action potential. The basic concept of PSI-assisted generation of an action potential is illustrated schematically in Fig. 2, where, following photon absorption, the normal function of PSI triggers a vectorial charge separation by electron donation from P700 to the  $F_{AB}$  electron acceptor complex. Cells may be either hyperpolarized or depolarized, depending on the orientation of PSI in the membrane. Fig. 3 is a schematic illustration of an isolated PSI reaction center.

This project builds on the recent progress by Humayun et al. [3] on pattern electrical stimulation of the human retina. Whereas in that work visual perceptions were elicited by electrical stimulation of blind human retinas using

## Report Documentation Page

<b>Report Date</b> 25 Oct 2001	<b>Report Type</b> N/A	<b>Dates Covered (from... to)</b> -
<b>Title and Subtitle</b> Application of Photosynthesis to Artificial Sight	<b>Contract Number</b>	
	<b>Grant Number</b>	
	<b>Program Element Number</b>	
<b>Author(s)</b>	<b>Project Number</b>	
	<b>Task Number</b>	
	<b>Work Unit Number</b>	
<b>Performing Organization Name(s) and Address(es)</b> Chemical Technology Division Oak Ridge National Laboratory Oak Ridge, TN	<b>Performing Organization Report Number</b>	
<b>Sponsoring/Monitoring Agency Name(s) and Address(es)</b> US Army Research, Development & Standardization Group (UK) PSC 803 Box 15 FPO AE 09499-1500	<b>Sponsor/Monitor's Acronym(s)</b>	
	<b>Sponsor/Monitor's Report Number(s)</b>	
<b>Distribution/Availability Statement</b> Approved for public release, distribution unlimited		
<b>Supplementary Notes</b> Papers from 23rd Annual International Conference of the IEEE Engineering in Medicine and Biology Society, October 25-28, 2001, held in Istanbul, Turkey. See also ADM001351 for entire conference on cd-rom., The original document contains color images.		
<b>Abstract</b>		
<b>Subject Terms</b>		
<b>Report Classification</b> unclassified	<b>Classification of this page</b> unclassified	
<b>Classification of Abstract</b> unclassified	<b>Limitation of Abstract</b> UU	
<b>Number of Pages</b> 3		

electronics, the present project focuses on light-activation by integral membrane PSI reaction centers that have been inserted into the membranes of retinal bipolar and/or ganglion cells. The overall conceptual idea is illustrated schematically

### III. RESULTS

The following results are reported: (1) measurement of open circuit electrostatic potentials from isolated PSI reaction centers [1]; (2) measurement of hydrogen photoevolution from platinized PSI reaction centers under closed circuit conditions using the rate of hydrogen evolution as a measure of current flow [2]; (3) measurement of functional PSI activity after they have been inserted into the liposomes.

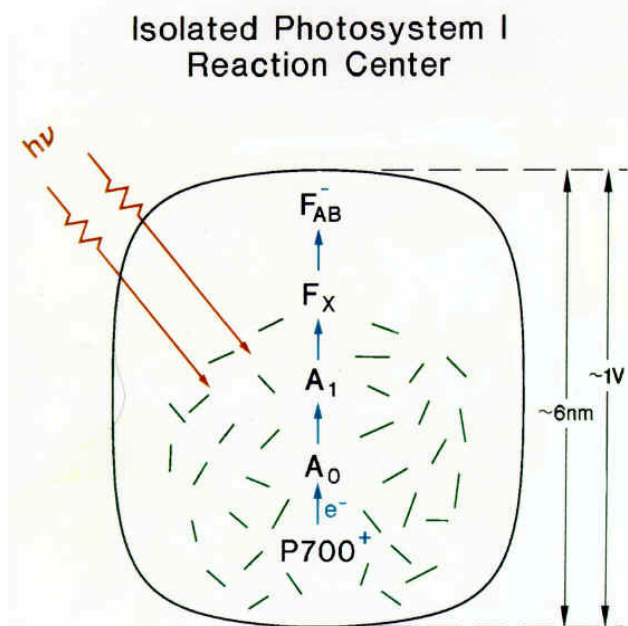

Figure 3 Schematic illustration of the isolated Photosystem I reaction center.

in Fig. 4 where PSI proteoliposomes are used as the carrier for insertion of PSI reaction centers into the mammalian cells.

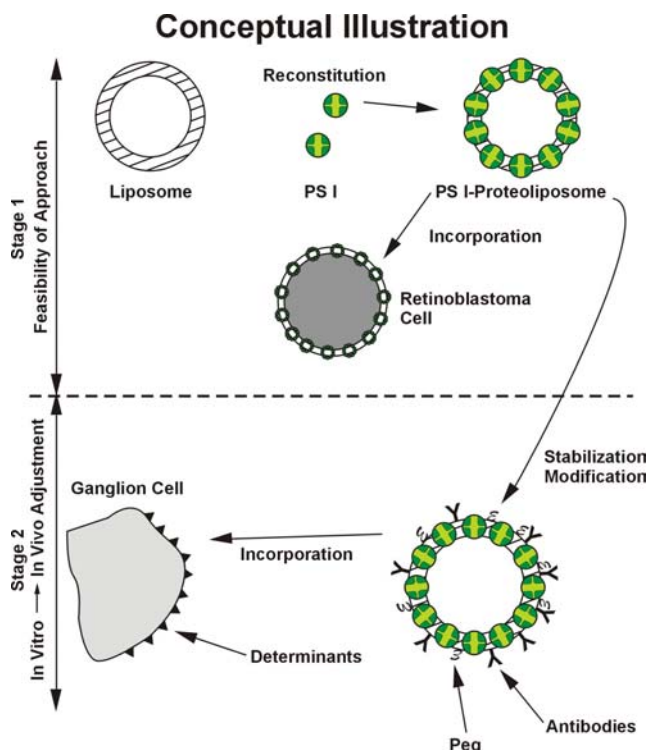

Figure 4 Illustration of liposome-assisted insertion of PSI reaction centers into mammalian cell membranes.

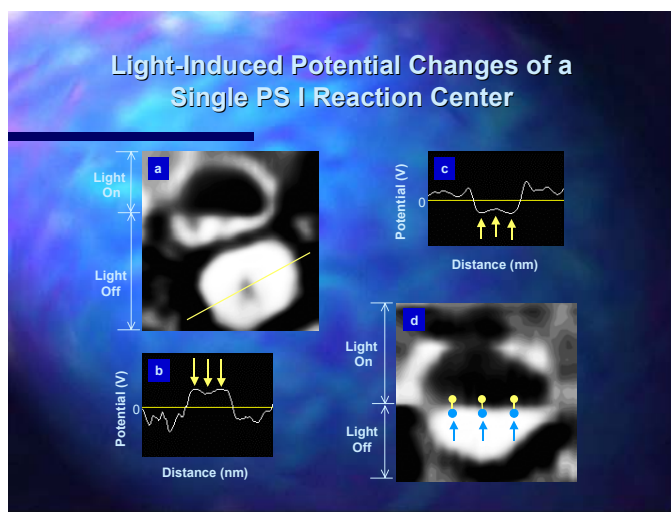

Figure 5 Kelvin force microscopy images and cross-sectional voltage profiles at the periphery and center of a single PSI reaction center. See table of for a summary of the measurements.

The light on minus light off of the PSI reaction centers is approximately 1 V. The following table, taken from the data of reference 1 summarizes the photovoltage measurements

#### PS I Photovoltage Topography: Summary of Three Types of Measurements

The vertical arrows in above figure indicate three selected voltage points we used in this table: the two extremities and the center.

	Dark (A)	Light (B)	(B - A) <sup>a</sup>	Light-Dark <sup>b</sup>
Periphery 1 (V)	0.77 ± 0.14	-0.47 ± 0.26	-1.24 ± 0.29	-1.13 ± 0.14
Center (V)	0.62 ± 0.08	-0.41 ± 0.24	-1.03 ± 0.25	-0.97 ± 0.04
Periphery 2 (V)	0.99 ± 0.20	-0.59 ± 0.26	-1.58 ± 0.32	-1.20 ± 0.19
No. of PS I Averaged	12	22		4

<sup>a</sup> Calculated difference between columns B and A.  
<sup>b</sup> On the same PS I.

Fig. 6 is a schematic illustration of a platinized PSI reaction center. We have shown that the coupled system of platinized PSI reaction centers, sodium ascorbate and plastocyanin is capable of sustained photoevolution of molecular hydrogen [2]. Since the midpoint redox potential of hydrogen evolution at pH 7 is more negative than -0.4 V, vs. the normal

hydrogen electrode, it follows that whether operating under open or closed circuit conditions, PSI has enough ‘horsepower’ to trigger a neural potential.

this may be the first example of insertion of functional plant proteins into mammalian cells for restoration of a non-plant physiological function.

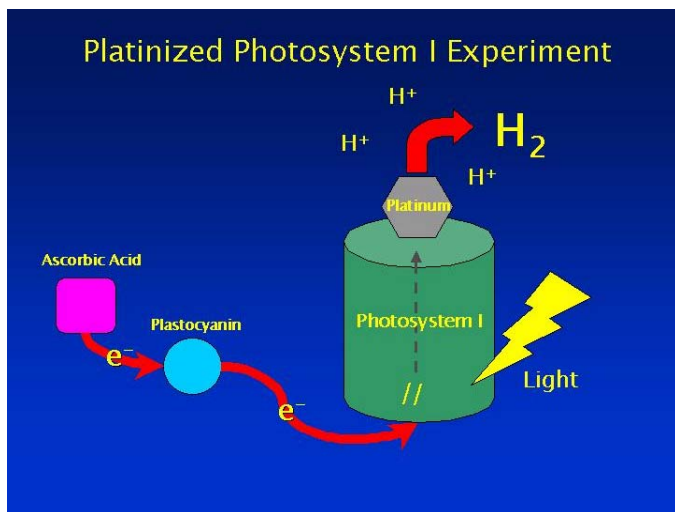

Figure 6 Illustration of hydrogen-evolving system comprised of platinized PSI, sodium ascorbate and plastocyanin.

The diagnostic assay for functional PSI reaction centers is absorption spectroscopy at 700 nm. Fig. 7 demonstrates functionality of PSI reaction centers that have been inserted into liposomes.

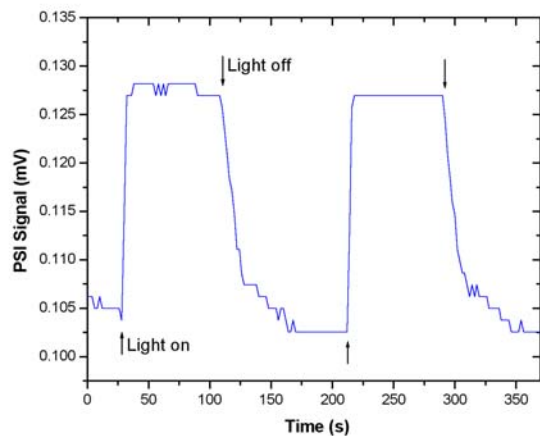

Figure 7 P700 absorption spectroscopy of Photosystem I reaction centers that have been inserted into liposome membranes

#### IV. DISCUSSION

This paper reports an idea and preliminary data for the application of isolated Photosystem I reaction centers to the problem of age-related macular degeneration and retinitis pigmentosa. While this work is still in its infancy, it is clear that isolated Photosystem I reaction centers have potentially interesting photophysical and photochemical properties for restoration of photoreceptor activity to cells. If successful,

#### ACKNOWLEDGMENT

This research was supported the Office of Science, Department of Energy and the Oak Ridge National Laboratory Director’s Research and Development fund. Oak Ridge National Laboratory is managed by UT-Battelle, LLC, for the U.S. Department of Energy under contract DE-AC05-00OR22725.

#### REFERENCES

- [1] I. Lee, J. W. Lee, A. Stubna, and E. Greenbaum, “Measurement of Electrostatic Potentials Above Oriented Photosystem I Reaction Centers” *J. Phys. Chem. B* **104**, 2439-2443 (2000).
- [2] J. F. Millsaps, B. D. Bruce, J. W. Lee, and E. Greenbaum, “Nanoscale Photosynthesis: Photocatalytic Production of Hydrogen by Platinized Photosystem I Reaction Centers,” *Photochem. Photobiol.* in press (2001).
- [3] M. S. Humayun, de Juan, E., Weiland, J. D., Dagnelie, G., Katona, S., Greenberg, R., and Suzuki, S., “Pattern electrical stimulation of the human retina,” *Vis. Res.* **39**, 2569–2576 (1999)
- [4] L. Stryer, *Biochemistry* 4<sup>th</sup> ed., W. H. Freeman and Company, New York, (1995).