

AFRL-SN-WP-TM-2003-1014

**MODE-LOCKED MULTIFUNCTION
TARGET IDENTIFICATION**



**Rita D. Peterson
Kenneth L. Schepler**

**Electro-Optical Branch (AFRL/SNJW)
Threat and Target Detection Technology Division
Sensors Directorate
Air Force Research Laboratory, Air Force Materiel Command
Wright-Patterson Air Force Base, OH 45433-7318**

JANUARY 2003

Final Report for 29 March 2000 – 31 December 2002

Approved for public release; distribution is unlimited.

This material is declared a work of the U. S. Government and is not subject to copyright protection in the United States.

**SENSORS DIRECTORATE
AIR FORCE RESEARCH LABORATORY
AIR FORCE MATERIEL COMMAND
WRIGHT-PATTERSON AIR FORCE BASE, OH 45433-7318**

NOTICE

USING GOVERNMENT DRAWINGS, SPECIFICATIONS, OR OTHER DATA INCLUDED IN THIS DOCUMENT FOR ANY PURPOSE OTHER THAN GOVERNMENT PROCUREMENT DOES NOT IN ANY WAY OBLIGATE THE US GOVERNMENT. THE FACT THAT THE GOVERNMENT FORMULATED OR SUPPLIED THE DRAWINGS, SPECIFICATIONS, OR OTHER DATA DOES NOT LICENSE THE HOLDER OR ANY OTHER PERSON OR CORPORATION; OR CONVEY ANY RIGHTS OR PERMISSION TO MANUFACTURE, USE, OR SELL ANY PATENTED INVENTION THAT MAY RELATE TO THEM.

THIS REPORT IS RELEASABLE TO THE NATIONAL TECHNICAL INFORMATION SERVICE (NTIS). AT NTIS, IT WILL BE AVAILABLE TO THE GENERAL PUBLIC, INCLUDING FOREIGN NATIONS.

THIS TECHNICAL REPORT HAS BEEN REVIEWED AND IS APPROVED FOR PUBLICATION.



Kenneth L. Schepler
Principal Scientist
EOCM Technology Branch

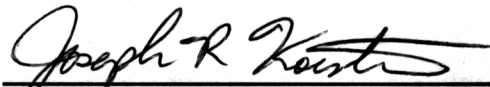

Joseph R. Koesters, Chief
EOCM Technology Branch
EO Sensors Technology Division



James A. Godsey, Colonel, USAF
Chief, EO Sensors Technology Division
Sensors Directorate

Do not return copies of this report unless contractual obligations or notice on a specific document require its return.

REPORT DOCUMENTATION PAGE

Form Approved
OMB No. 0704-0188

The public reporting burden for this collection of information is estimated to average 1 hour per response, including the time for reviewing instructions, searching existing data sources, gathering and maintaining the data needed, and completing and reviewing the collection of information. Send comments regarding this burden estimate or any other aspect of this collection of information, including suggestions for reducing this burden, to Department of Defense, Washington Headquarters Services, Directorate for Information Operations and Reports (0704-0188), 1215 Jefferson Davis Highway, Suite 1204, Arlington, VA 22202-4302. Respondents should be aware that notwithstanding any other provision of law, no person shall be subject to any penalty for failing to comply with a collection of information if it does not display a currently valid OMB control number. **PLEASE DO NOT RETURN YOUR FORM TO THE ABOVE ADDRESS.**

1. REPORT DATE (DD-MM-YY) January 2003		2. REPORT TYPE Final		3. DATES COVERED (From - To) 03/29/2000 – 12/31/2002	
4. TITLE AND SUBTITLE MODE-LOCKED MULTIFUNCTION TARGET IDENTIFICATION				5a. CONTRACT NUMBER IN-HOUSE	
				5b. GRANT NUMBER	
				5c. PROGRAM ELEMENT NUMBER 61102F	
6. AUTHOR(S) Rita D. Peterson Kenneth L. Schepler				5d. PROJECT NUMBER 2301	
				5e. TASK NUMBER AN	
				5f. WORK UNIT NUMBER 00	
7. PERFORMING ORGANIZATION NAME(S) AND ADDRESS(ES) Electro-Optical Branch (AFRL/SNJW) Threat and Target Detection Technology Division Sensors Directorate Air Force Research Laboratory, Air Force Materiel Command Wright-Patterson Air Force Base, OH 45433-7318				8. PERFORMING ORGANIZATION REPORT NUMBER AFRL-SN-WP-TM-2003-1014	
9. SPONSORING/MONITORING AGENCY NAME(S) AND ADDRESS(ES) Sensors Directorate Air Force Research Laboratory Air Force Materiel Command Wright-Patterson Air Force Base, OH 45433-7318				10. SPONSORING/MONITORING AGENCY ACRONYM(S) AFRL/SNJW	
				11. SPONSORING/MONITORING AGENCY REPORT NUMBER(S) AFRL-SN-WP-TM-2003-1014	
12. DISTRIBUTION/AVAILABILITY STATEMENT Approved for public release; distribution is unlimited.					
13. SUPPLEMENTARY NOTES This material is declared a work of the U. S. Government and is not subject to copyright protection in the United States. This report contains color.					
14. ABSTRACT (Maximum 200 Words) We have demonstrated a target ranging and identification technique based upon timing-modulation of a mode-locked laser coupled with a fast detector. Range-to-target and target depth information have been determined, with a resolution of better than 25 cm at signal-to-noise ratios below 0.01. Modeling suggests that laser average power requirements remain a challenge, with upward of 100 W likely needed for extension of this technique to ranges over 10 km, but improvements in overall system throughput would allow realization of its potential.					
15. SUBJECT TERMS laser radar, target identification, signal processing					
16. SECURITY CLASSIFICATION OF:			17. LIMITATION OF ABSTRACT: SAR	18. NUMBER OF PAGES 28	19a. NAME OF RESPONSIBLE PERSON (Monitor) Kenneth L. Schepler 19b. TELEPHONE NUMBER (Include Area Code) (937) 255-3804 x274
a. REPORT Unclassified	b. ABSTRACT Unclassified	c. THIS PAGE Unclassified			

TABLE OF CONTENTS

<u>SECTION</u>	<u>PAGE</u>
1. INTRODUCTION	1
2. EXPERIMENTAL TECHNIQUES	2
3. DATA ACQUISITION AND ANALYSIS	4
4. FURTHER RESEARCH	6
APPENDIX A – PAPER SUBMITTED TO <i>APPLIED OPTICS</i>	7
APPENDIX B – DATA COLLECTION AND ANALYSIS PROGRAM.....	19

ACKNOWLEDGMENTS

The authors wish to thank Mr. Gary Smith and Maj. Michael Hawks (Air Force Research Laboratory, Sensors Directorate), and Dr. Kenneth Dinndorf (CTI Corporation) for helpful technical discussions. We also gratefully acknowledge funding for this research from the Air Force Office of Scientific Research (AFOSR), and the Air Force Research Laboratory Sensors Directorate (AFRL/SN).

1. INTRODUCTION

This technical report describes our demonstration of a target ranging and identification technique based upon timing-modulation of a mode-locked laser coupled with a fast detector. Range-to-target and target depth information have been determined with a resolution of better than 25 cm at signal-to-noise ratios below 0.01. We also present a simple performance model offering a first-order indication of the average power required from a laser for the mode-locked technique to work at ranges of 10 km or more.

The bulk of this information is contained in Appendix A, in the form of a paper prepared for submission to the journal *Applied Optics*. The sections below will focus on information not included in the paper but of potential use to those attempting to replicate or extend the experiments performed.

2. EXPERIMENTAL TECHNIQUES

To generate the mode-locked pulse trains required for our experiments, we began with a diode-pumped Nd:YVO₄ laser passively mode-locked by means of a semiconductor saturable absorber. This laser, manufactured by Time-Bandwidth Products, was basically a standard product modified in two key ways. First, the laser resonator was lengthened to produce a pulse repetition rate of 40 MHz rather than the standard 80 MHz or higher. Second, an electro-optic modulator was added external to the resonator, along with several turning mirrors to form the extended beam path traveled by pulses deflected by the modulator.

The modulator driver was controlled by a pattern generator, which could be programmed with a user-defined or computer-generated pattern entered as a string of 1's (voltage low – pulse sent straight through) and 0's (voltage high – pulse deflected through delay path). Delayed pulses were redirected along the original beam path by a polarizing beamcube placed after the modulator.

On the whole, this system performed reasonably well in the experiments conducted. Several instrumental idiosyncrasies and unforeseen issues required specific attention, however, in order for the experiments to proceed successfully. First of these is that the laser itself, while fundamentally reliable, required significant optimization of alignment almost every time it was turned on for operation at the rated output power with good beam quality. Because of the resonator length and the large number of mirrors involved, even small realignment of the resonator steered the output beam enough to require realignment of all optics downstream, in particular those controlling overlap of the delayed and undelayed pulses. While the specifics of this problem are peculiar to the laser used, and were manageable in a laboratory environment, alignment stability should be considered in identifying new lasers for follow-on experiments, and certainly for prototypes or fielded systems.

A second issue involved time synchronization of the various electronic components of the experiment. Ordinarily, when using a pulsed laser, there is a power supply, Pockels cell driver, or modulator driver controlling the laser repetition rate which can be used to trigger other equipment. In the case of a passively mode-locked laser, however, there are no active elements in the resonator, and therefore no such electronic signal available for triggering. Furthermore, the actual repetition rate of the laser exhibited some variation which, though small (less than 0.5 percent), was sufficient to prevent consistent triggering simply by configuring the pattern generator for a repetition rate of 40 MHz. It worked best simply to trigger using the signal from a silicon photodiode monitoring leakage from one of the laser cavity mirrors. Any passively mode-locked laser will likely need to rely on this type of arrangement.

An added complication arose from the fact that while the laser repetition rate was 40 MHz, the modulator driver was capable of operating only up to 30 MHz. This was easily worked around by constraining the pulse pattern in such a manner that the voltage level was never switched after just one pulse at the previous level. Clearly, however, this situation is not desirable. While other considerations will no doubt have a greater impact on the optimal repetition rate for the mode-

locked target ID technique, one must also consider the tradeoff between a modulator driver fast enough to keep up with the laser, and a laser resonator long enough (and inconveniently voluminous) to produce a manageably “low” repetition rate.

In the course of performing mode-locked target ID experiments, the length of the delayed optical path was increased from 13 inches to about 52 inches. In both cases, but especially in the second, the additional beam divergence occurring along the extended path resulted in a spot size at the target that was significantly larger for the delayed pulses than for those undelayed. This translated into a lower intensity at the target, and resulting lower intensity of scattered return at the detector for the delayed pulses. To compensate, a weak focusing lens was placed in the extended path, making the spot sizes of the delayed and undelayed pulses more closely matched.

3. DATA ACQUISITION AND ANALYSIS

The mode-locked target ID technique relies on mathematical cross-correlation of a known, outgoing pulse train with its scattered return incident upon the detector. This required collection of two data sets in a format amenable to mathematical manipulation by computer. Given that a digitizing oscilloscope was already in use to monitor the laser output for alignment and diagnostic purposes, the dataset corresponding to the signal on the detector was obtained by programming the computer to read the trace from the appropriate oscilloscope channel. The outgoing pulse train, on the other hand, was represented by a computer-generated model, with the modulation pattern, pulsewidth, pulse delay time, and number of data points as inputs.

We suspected at one point that the deviation in pulse shape of the mathematically modelled pulse train from the actual outgoing pulse train was adversely affecting cross-correlation results. To test this, a holographic beam sampler was placed in the beam to diffract a 1 percent sample of the laser output onto a detector. This signal was then used as the “known outgoing signal” in place of the mathematical model. Cross-correlation traces obtained using this method showed no difference from those made with the model, however, indicating that, at least in the current configuration, there was no disadvantage to using a modelled signal.

Use of the oscilloscope in acquiring the detector signal introduced an unforeseen limitation arising from the storage capacity of the oscilloscope itself. The 20-pulse pattern used in most experiments could be displayed clearly and entirely on the scope with the time scale set to 50 ns/division. On this fast a time scale, however, the scope originally used would collect a maximum of 500 data points. Given a pulse period of 25 ns and an electronically broadened pulsewidth (due to detector bandwidth limitation) of about 0.7 ns, this translates into one data point per pulse, less than what is needed to resolve the pulses properly, and precluding any increase in the number of pulses in the outgoing train. A suitable replacement oscilloscope was found, capable of collecting up to 8 data points per 1 ns time increment, or 4,000 points for the pulse train described above. Any future experiments, however, will need to consider instrumental “depth of storage” in some form or other, especially as the pulse train length is increased to measure longer ranges without ambiguity.

A desktop computer performed all of the data collection and analysis, using programs written in the LabVIEW environment. These programs took advantage of drivers and control subroutines obtained from National Instruments for the particular instruments used in the experiment. The primary program used for data collection and analysis is explained in detail in Appendix B.

Initially, we also used a subroutine included as part of LabVIEW to perform the cross-correlation of the outgoing and scattered return signal traces. The subroutine performed the cross-correlation in such a way as to produce a trace twice as long as the input trace. Also, since the first pulse in the mode-locked pulse train was generally not the first pulse in the scattered return trace due to how the oscilloscope was triggered (that is, the trace was rotated), the outgoing signal trace could not find its match.

Both of these issues were resolved by abandoning the LabVIEW cross-correlation routine and writing our own. The new routine operated by simply rotating the outgoing trace as many times as it contained data points, while at each rotation multiplying the outgoing and scattered return traces together and summing all the points in the product trace to get the “area under the curve”. This ensured that the outgoing signal trace found its match, and produced a cross-correlation spectrum the same length of the input traces.

The disadvantage of the new subroutine was that each cross-correlation took longer to complete, perhaps 0.5 s. This may not seem like much, but when averaging a number of cross-correlations to improve the signal-to-noise ratio, it adds up quickly. While long processing times were not a problem in the laboratory, and LabVIEW is an appropriate programming environment in this setting, processing could likely be sped up considerably by writing code in a more streamlined language.

4. FURTHER RESEARCH

The scope of this effort was limited to demonstration of the basic mode-locked target ID technique in the laboratory, working at ranges of no more than several meters. The logical extension of this research, then, is to repeat the experiments under more realistic conditions, increasing the range to several hundred meters. The performance model we developed to estimate laser power requirements as a function of range suggests that our existing 0.5-W laser and detection system can be used at ranges up to 500 m. These intermediate ranges can be accessed by directing the laser toward targets through the tower window or out through the periscope in Bldg. 622.

The success of such experiments can be enhanced by a few simple improvements. First, the signal at the detector can be significantly increased by replacing the 5-cm-diameter collection lens with a 10-cm-diameter lens. Second, focusing of the delayed pulses can be optimized so that they have the same spot size at the target as the undelayed pulses. Third, the Newport amplified InGaAs PIN detector can be replaced by a detector with a larger bandwidth, lower noise, or other characteristics leading to improved signal-to-noise in the experiment. Care must be taken, however, that a higher detector bandwidth not exceed the capability of the oscilloscope or other instruments used.

Should mid-range experiments yield promising results and further research be planned, significant improvements in the laser itself will become necessary. Obviously, more output power will be needed, at least an order of magnitude more just for ranges of several km. The resonator design, however, will also require attention. In our existing laser, the long resonator needed for a repetition rate of 40 MHz takes up a large volume, most of it empty space, even with the use of several extra mirrors to fold the cavity back on itself to conserve space. The volume taken up by the laser will require substantial reduction for a mode-locked target ID system to be flightworthy.

One possible alternative would be to base the system on a fiber laser, in which case the resonator can easily be coiled up into a small volume. Fiber lasers at the eyesafe wavelength of 1.5 μm have seen extensive development for telecommunications uses, and offer additional advantages in stability, robustness, and ease of packaging.

Timing modulation of a 40-MHz pulse train for target ranging and identification

Rita D. Peterson and Kenneth L. Schepler
Air Force Research Laboratory (AFRL/SNJW), 3109 P St.
Wright-Patterson AFB OH 45433-7700
Rita.Peterson@wpafb.af.mil

We have demonstrated a target ranging and identification technique based upon timing-modulation of a mode-locked laser coupled with a fast detector. Range to target and target depth information have been determined with a resolution of better than 25 cm at signal-to-noise ratios below 0.01. Modelling suggests laser average power requirements remain a challenge, with upwards of 100 W likely needed for extension of this technique to ranges over 10 km, but improvements in overall system throughput would allow realization of its potential .

OCIS Codes: 280.3400 (Laser range finder), 070.1170 (Analog optical signal processing)

Introduction

A common method optically measuring the range to a target and the target's depth is to use direct detection based upon flood-illumination with high-energy laser pulses.¹ The laser wavelength must be amenable to high sensitivity detection, transmitted well by the atmosphere, and "eyesafe", defined as not focusable on the retina of the eye for the safety of people in the area. These criteria are best met by a wavelength near 1.5 μm . For high-resolution, time-dependent detection of target features the laser pulse must also be very short, less than 1 ns for a resolution on the order of 30 cm. This combination of laser properties is difficult to achieve. Q-switching of bulk solid state lasers does not produce pulses as short as 1 ns, and while microchip lasers can emit such short pulses, their small gain volume limits pulse energy to a few microjoules. Short, high energy pulses also have a greater likelihood of damaging components in the laser and in the beam forming optics.

As an alternative, we have investigated the feasibility of a target identification (ID) system based on a mode-locked laser and a high-speed detector, essentially replacing the single high-energy pulse used in burst illumination with a train of many less energetic pulses. Mode-locked lasers easily produce multiWatt output with pulsewidths in the tens of ps for excellent resolution, and repetition rates in the tens of MHz allowing signal averaging over multiple pulse trains to improve sensitivity. While peak powers may be high, average powers are well below the damage thresholds of typical optics.

Modelocked lasers historically have been complex and temperamental, but recent advances have led to devices that are highly robust, efficient and compact. Passively modelocked lasers such as the one used in this research are now commercially available and could easily be hardened for field use. Use of passively modelocked fiber lasers should also reduce laser sensitivity to vibration and temperature changes. For example, U.S. Air Force funded research by Sharp and Spock demonstrated a 1.9- μm fiber laser with a 200-fs pulse width, passively modelocked by a saturable absorber². Target ranging and identification will not require such short pulses, but these results illustrate the progress that has been made in fiber lasers over the last decade.

Figure 1 depicts our basic technique, in which a modulated pulse train is directed toward a target, and the scattered return is collected by a fast detector. In the absence of modulation, each laser pulse is indistinguishable from the next, making it impossible to determine when a given pulse returns to the detector after scattering off the target. Modulation enables us to selectively delay pulses according to a pseudo-random pattern such that the pulse train as a whole is recognizable upon its return. This is done using a modulator external to the laser cavity which either passes the laser pulse straight through, or deflects it along an extended path resulting in a small delay.

The detection system “recognizes” the scattered pulse train by mathematically cross-correlating the signal at the detector with the known outgoing pulse train. The cross-correlation

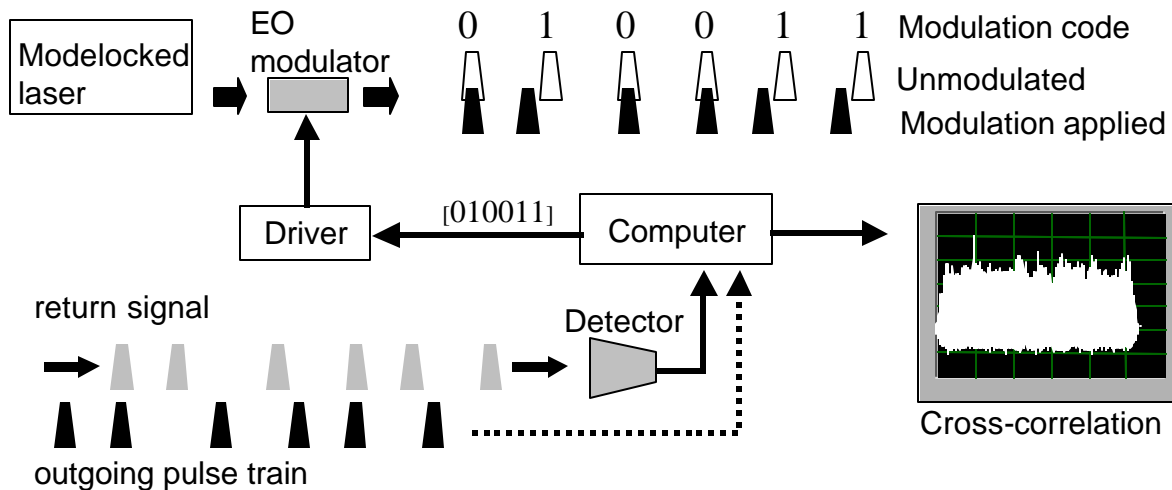

Figure 1. Schematic of mode-locked target identification technique.

process entails stepping one trace across the other, while multiplying the two traces together and measuring the area under the resulting curve at each step. This yields a third trace consisting of the area under the curve as a function of step, easily converted here into units of time. The area under the curve of the product trace will reach a maximum at the point where the two traces overlap, in other words, where the known outgoing pulse train finds its match in the scattered pulse train collected by the detection system.

The position in time of this maximum can be precisely identified by the computer. With adjustment for any offset in the oscilloscope display, the peak's time coordinate corresponds to the round trip time t of the return signal, from which the range to the target r can easily be calculated using the equation $r = tc/2$ where c is the speed of light. Measurement of the change in range with time will additionally allow determination of the relative velocity of the target.

The same signal can be used to perform high resolution characterization of target profile as well. An extended target will essentially smear out a picosecond modelocked pulse to a width of $2L/c$ where L is the depth of the target. (This places a constraint on the laser repetition rate since if the pulses are too close together, an extended target will smear them into each other.) Repetitive accumulation of the return for each pulse train will build up a signal characteristic of the extended target, in much the same way as the averaged signal builds up from multiple sweeps in a digital oscilloscope. The averaged modelocked pulse train return can thus yield precise range information, high-resolution target depth information, and relative velocity.

Experiment

Our objective was to demonstrate the basic technique, and to collect data for modelling the laser power required to extend it to useful ranges. Experiments involved scattering the laser output off test targets on the laboratory table to characterize the accuracy and resolution of ranging measurements, the return produced by multiple or extended targets, and the signal-to-noise (SNR) limits of this method.

Although $1.5 \mu\text{m}$ may be the ideal wavelength for this application, for convenience these experiments were performed using a commercially available Nd laser operating at $1.06 \mu\text{m}$, specifically a Time-Bandwidth Products Nd:YVO₄ laser, model GE-100-VAN-HP. The laser was diode-pumped and passively mode-locked by means of a saturable absorber. It produced an average output power of 0.5 W with a repetition rate of 40 MHz and a pulsewidth of 45 ps.

The basic experimental setup is shown in Figure 2. The laser output was modulated using an electro-optic modulator external to the laser cavity. The modulator driver was controlled by an Agilent model 81104A pattern generator, which in turn was controlled by a computer through the issuance of a binary code. A value of 0 in the code triggered low voltage from the driver, in which case the pulse passed straight through the modulator. A value of 1 triggered high voltage, in which case the pulse was deflected through an extended optical path,

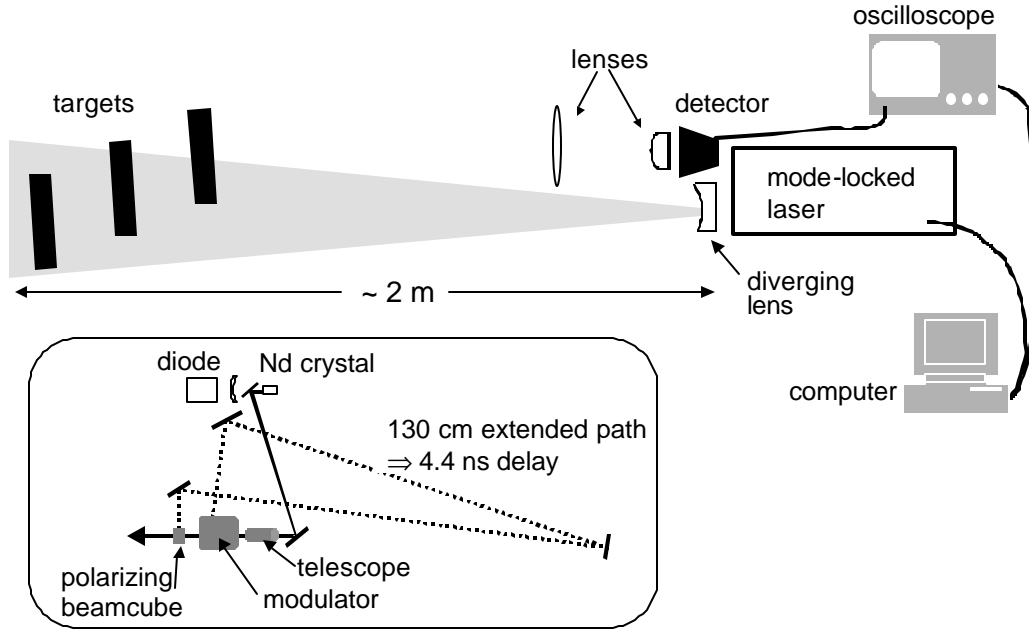

Figure 2. Experimental setup. Inset shows details of mode-locked laser and extended optical path.

imparting a delay of about 4 ns relative to the direct path. For experimental purposes, a pattern of 20 pulses was typically used, although a functional system would likely use a much longer pattern.

A diverging lens placed after the modulator expanded the beam which was then scattered by painted metal test targets placed downstream. A pair of positive lenses collected the scattered return and focused it onto a Newport amplified InGaAs PIN detector. The detector bandwidth of 1.5 GHz was not sufficient to resolve the 45 ps pulsewidth, but the electronically broadened pulsewidth of 0.7 ns was short enough for a resolution of 30 cm or better.

The train of pulses scattered by the target onto the detector was displayed on an oscilloscope and read by the computer, which then performed the cross-correlation process described above, using a mathematically generated trace to represent the outgoing pulse train. The x-axis of the resulting cross-correlation corresponds to time, allowing straightforward determination of the round trip time of the return pulse from the position of the cross-correlation peak. The cross-correlation process was performed for several pulse trains and the results averaged to improve SNR. Mathematical operations, data acquisition, and control of the pattern generator were performed using National Instruments LabVIEW software.

The simplest case entailed measuring range to a single target. The target was first placed close to the laser and detector at a “known” location to give a baseline cross-correlation peak position. The target was then moved to an “unknown” location over 1 m away from the laser

aperture. Comparison of the second cross-correlation peak position with the first yielded the distance between the target and the baseline position with an accuracy of better than 5 cm.

To assess the SNR limits of the technique, this experiment was repeated with filters of known attenuation in front of the detector. These results are compared with those for the unattenuated case in Figure 3. Figure 3a shows the raw signal for a single 20-pulse train, without attenuation. Figure 3b shows the cross-correlation of this trace, with its peak clearly visible. (Averaging was not performed for the unattenuated, high-signal case since it was not needed for unambiguous peak identification.) Figure 3c shows the raw signal for the attenuated case, corresponding to $\text{SNR} = 0.075$. Averaging this signal using the oscilloscope produced the trace shown in Figure 3d; the amplitude of the noise is greatly reduced, but the peak is still lost. Averaging the cross-correlations of 20 traces, however, produced the trace shown in Figure 3e, in which the peak is again clearly visible. The $\text{SNR} = 0.075$ limit determined in this experiment can likely be reduced further by additional signal averaging, and is in reasonable agreement with the $\text{SNR} = 0.1$ predicted by initial modelling.

The background level in the cross-correlation traces appears as a series of discrete peaks rather than a continuum of noise as in the preliminary modelling (see inset plot in Figure 1)

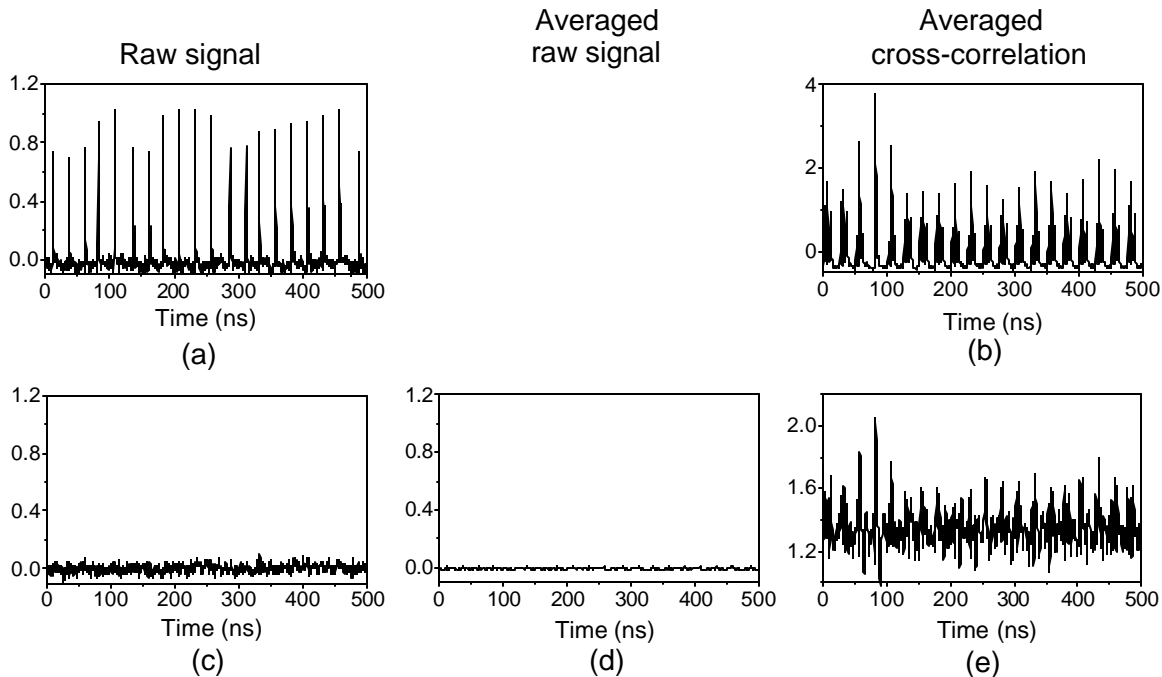

Figure 3. Raw signal and cross-correlation traces for a single target, with (a, b) and without (c, d, e) attenuation to simulate low SNR.

because of the relatively short pulse train used. The background peaks have a spacing that approximates the laser repetition rate, indicating the incomplete overlap when only some of the pulses in the outgoing pulse train overlap the scattered return signal. The trace maximum, however, occurs only when there is complete overlap, and can be unambiguously determined either by eye, or by computer algorithm.

To simulate an extended target with depth larger than the resolution limit of the system, multiple discrete targets were positioned downstream of the laser along the beam path, separated by various distances. The cross-correlation trace obtained for two targets placed 60 cm apart is shown in Figure 4a and 4b. The trace displays a double peak, with the 4 ns temporal peak separation corresponding to the 120 cm round trip target separation. A single large target placed to have an apparent depth of 60 cm would result in a single peak 4 ns wide.

This experiment was repeated with a target separation of 30.5 cm, and attenuating filters placed in front of the detector. Target separation was correctly determined for SNR down to 0.08 by averaging the cross-correlations of 50 pulse trains. The entire averaged cross-correlation trace for this case is shown in Figure 4c, with an expansion of the double peak in Figure 4d.

To demonstrate the depth resolution of the mode-locked laser technique, a series of measurements was made using three targets placed along the beam path at equal intervals. The

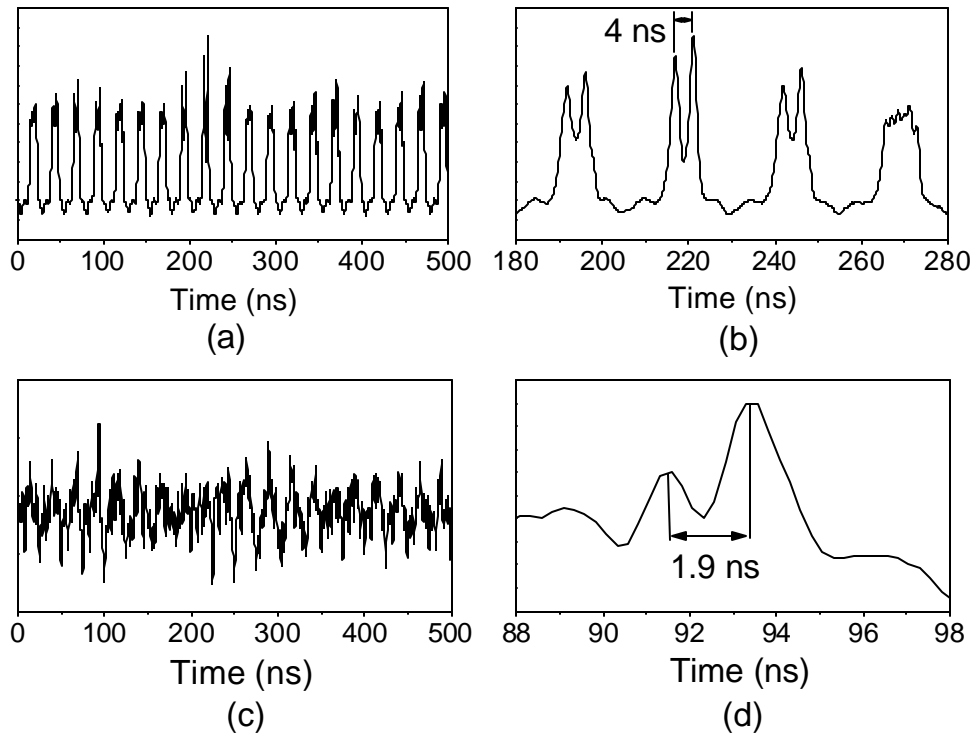

Figure 4. Cross-correlation traces for two targets with (a, b) and without (c, d) attenuation to simulate low SNR.. Plots on the right are expansions of peaks on the left.

results are shown in Figure 5. The three targets are individually resolvable down to a separation of about 25 cm, but as the separation is further reduced, resolution is lost, and they appear much as a single extended target with a depth as large as the overall separation. The final trace in the figure shows for comparison the cross-correlation for a single target placed at the midpoint of the three-target distribution.

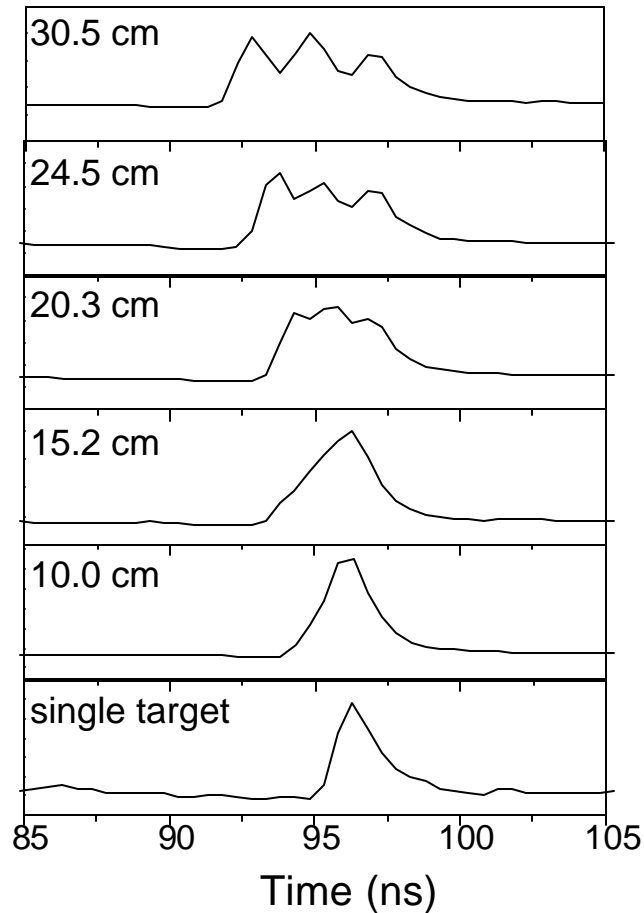

Figure 5. Cross-correlation peaks for 3 targets equally spaced along the beam path by the specified distance. Last trace shows data for single target for comparison.

To demonstrate ranging resolution, the range to a single target was measured for each of three positions, 15 cm apart. These results are shown in Figure 6. Although depth resolution is limited to about 20 cm in this case by detector bandwidth, range-to-target can clearly be determined with better resolution. The height of the cross-correlation peak increases with the intensity of scattering from the target, accounting for the differing peak heights in the figure. This dependence also contributes to the depth “signature” present in the broadened cross-correlation peaks from extended targets.

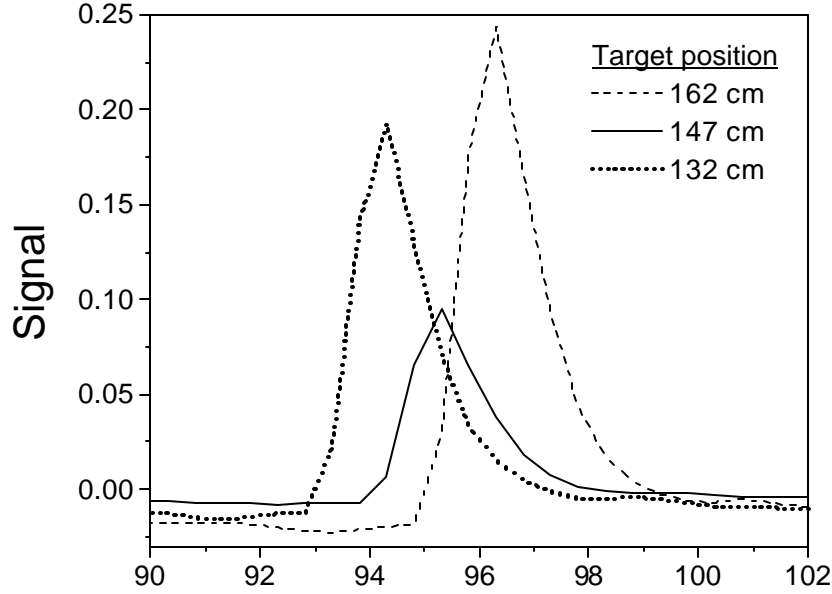

Figure 6. Cross-correlation peak for single target placed in each of three different positions relative to laser and detector.

Performance Modelling

A mathematical model was developed to estimate the laser output power necessary for extending the mode-locked laser technique to realistic ranges (> 1 km), and to determine the range limitation of our present equipment for help in planning future experimentation. The model was based upon the standard laser radar equation found in textbooks:

$$P_{sig} = \frac{P \sigma \Omega_{rcv}}{A_{tar}} T_{rcv} T_{trans} T_{atm}^2 \quad (1)$$

where P_{sig} is the power incident on the detector, P is the peak power of the laser, σ is the target cross section in m^2/str , Ω_{rcv} is the receiver solid angle, A_{tar} is the laser spot size at the target, T_{rcv} and T_{trans} give the transmission of the receiver and transmitter optics respectively, and T_{atm} is the atmospheric transmission at the laser wavelength³. The effects of atmospheric turbulence and possible obscurants were neglected, with atmospheric transmission approximated by a simple absorption coefficient, $\alpha \approx 5 \times 10^{-5} \text{ m}^{-1}$. It was also assumed that all the light collected by the receiver optic is focused onto the detector active area.

Once power incident on the detector is known, it can be compared with the detector noise to determine SNR as a function of laser power and range-to-target. Detector noise was calculated by explicitly summing the contributions of shot noise, generation-recombination noise, and Johnson noise for each detector considered, using the standard mathematical expressions for detector noise⁴. The resulting model is quite rudimentary, and serves mainly to give a first-order approximation of what may be possible. The specific values used in performing the calculations are listed in the table. Based upon our experimental results, a SNR of 0.1 was used as a threshold level

Table. Parameters used in performance modelling.

Parameter	Value
laser pulsewidth	45 ps
laser repetition rate	40 MHz
laser divergence (full angle)	2.6 mrad
laser wavelength	1.5 μm
target cross section	1 m^2/str
receiver optics transmission	0.9
transmitter optics transmission	0.9
atmospheric absorption coefficient	$5 \times 10^{-5} \text{ m}^{-1}$
receiver diameter	10 cm

To estimate laser power required for operation at ranges of several km or more, average power needed for SNR = 0.1 was calculated as a function of range for several different detectors. Only detectors with good response in the 1.5 μm region were considered, based upon the eventual requirement for eye safety. These results are plotted in Figure 7. The amplified InGaAs PIN is our existing detector. The unamplified InGaAs PIN and InGaAs APD represent other commercially available detectors. The trace marked “hypothetical InGaAs APD” was obtained by taking the best of the other three and assuming an order of magnitude reduction in detector noise, and a small improvement in bandwidth, improvements well within reach of given ongoing detector development work. Even in this best case, however, over 100 W average power will likely be needed from a laser to obtain sufficient return signal at the detector at ranges approaching 10 km.

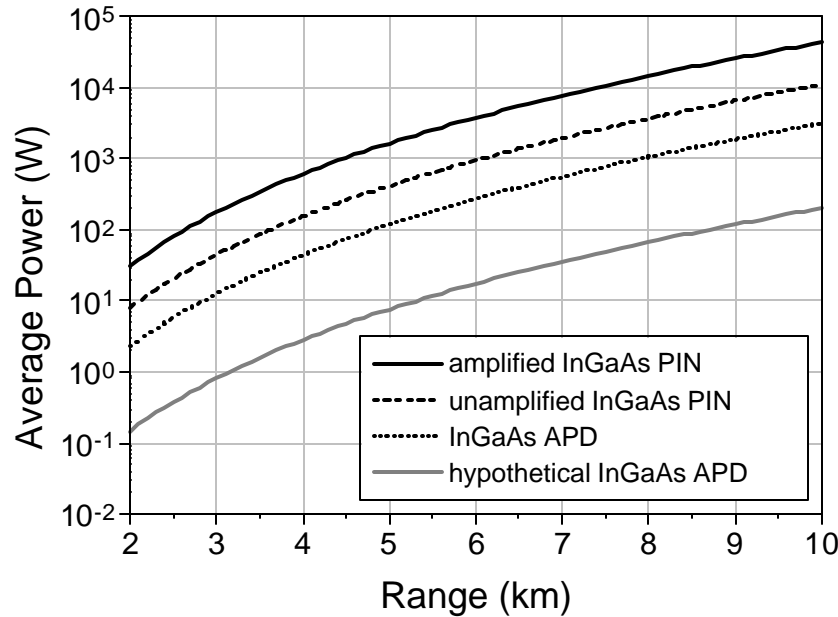

Figure 7. Average laser power required for SNR = 0.1 as a function of range to target.

Conclusions

The basic technique of using timing modulation of a mode-locked laser for target ranging and identification has been successfully demonstrated. Experiments indicate this technique can resolve target features at least as small as 25 cm, at signal to noise ratios below 0.1. Resolution is currently limited by detector bandwidth, and can be improved further by use of a faster detector, at the expense of reduced sensitivity and by extension reduced range. Return signal at the detector, and by extension the useful operating range of the system, can see similarly straightforward improvement by use of a larger collection optic.

Even with these simple improvements, however, mathematical models based upon the laser radar range equation suggest that upwards of 100 W average power would be required for application of the mode-locked laser technique at ranges of 10 km or more. This equates to over an order of magnitude more power than our modelocked laser produces, but 100-W modelocked lasers are now being built and demonstrated⁵, at least in the 1- μ m region. The power requirement could be significantly eased by improvements in the overall optical throughput of the system, such as the transmission of optical components, or noise reduction in the detector.

Improvements in technologies affecting system throughput, as well as in mode-locked lasers themselves, would rapidly enhance the immediate utility of the mode-locked laser technique. Its success in the laboratory shows that it certainly has potential. In the end, however, is likely to be most useful as one of several approaches to the task of target ranging and identification, perhaps used in conjunction with other methods and evolving technologies.

The authors wish to thank Mr. Gary Smith and Maj. Michael Hawks (Air Force Research Laboratory, Sensors Directorate), and Dr. Kenneth Dinndorf (CTI Corporation) for helpful technical discussions. We also gratefully acknowledge funding for this research from the Air Force Office of Scientific Research (AFOSR), and the Air Force Research Laboratory Sensors Directorate (AFRL/SN).

References

1. E. A. Watson, P. F. McManamon, and D. D. Smith, "Agile sensing using laser-based systems," in *Smart Imaging Systems*, B. Javidi, ed., SPIE Publishing, Bellingham, WA (2001).
2. R. C. Sharp, D. E. Spock, N. Pan, and J. Elliot, "180-fs passively mode-locked thulium fiber laser with a low threshold", *Optics Letters* **21**, 881-883 (1996).
3. See, for example, Albert V. Jelalian, *Laser radar systems*, (Boston, Artech House, 1992).
4. See, for example, Eustace L. Dereniak and Devon G. Crowe, *Optical radiation detectors*, (New York, Wiley, 1984).
5. R. Paschotta, F. Brunner, E. Innerhofer, T. Südmeyer, and U. Keller, "High average power femtosecond and picosecond lasers," OSA TOPS Vol. **68**, *Advanced Solid State Lasers*, M. E. Fermann and L. R. Marshall, eds. (OSA, Washington DC, 2002) pp. 117-120.

APPENDIX B DATA COLLECTION AND ANALYSIS PROGRAM

The data analysis and control program was written in the LabVIEW environment, and was structured to perform the following three main tasks:

1. Capture of the return signal trace from an oscilloscope
2. Generation of a modelled trace based on the known outgoing signal
3. Mathematical cross-correlation of return and outgoing (model) traces

Figure B-1 shows the front panel display of the LabVIEW program. The user specifies the oscilloscope channel displaying the detector signal, factors specifying the pulsewidth and delay length, the number of cross-correlation traces to be averaged, the number of data points in the oscilloscope trace, and the pattern code of 1's and 0's. The pattern length and any pulse generator error are displayed for user information.

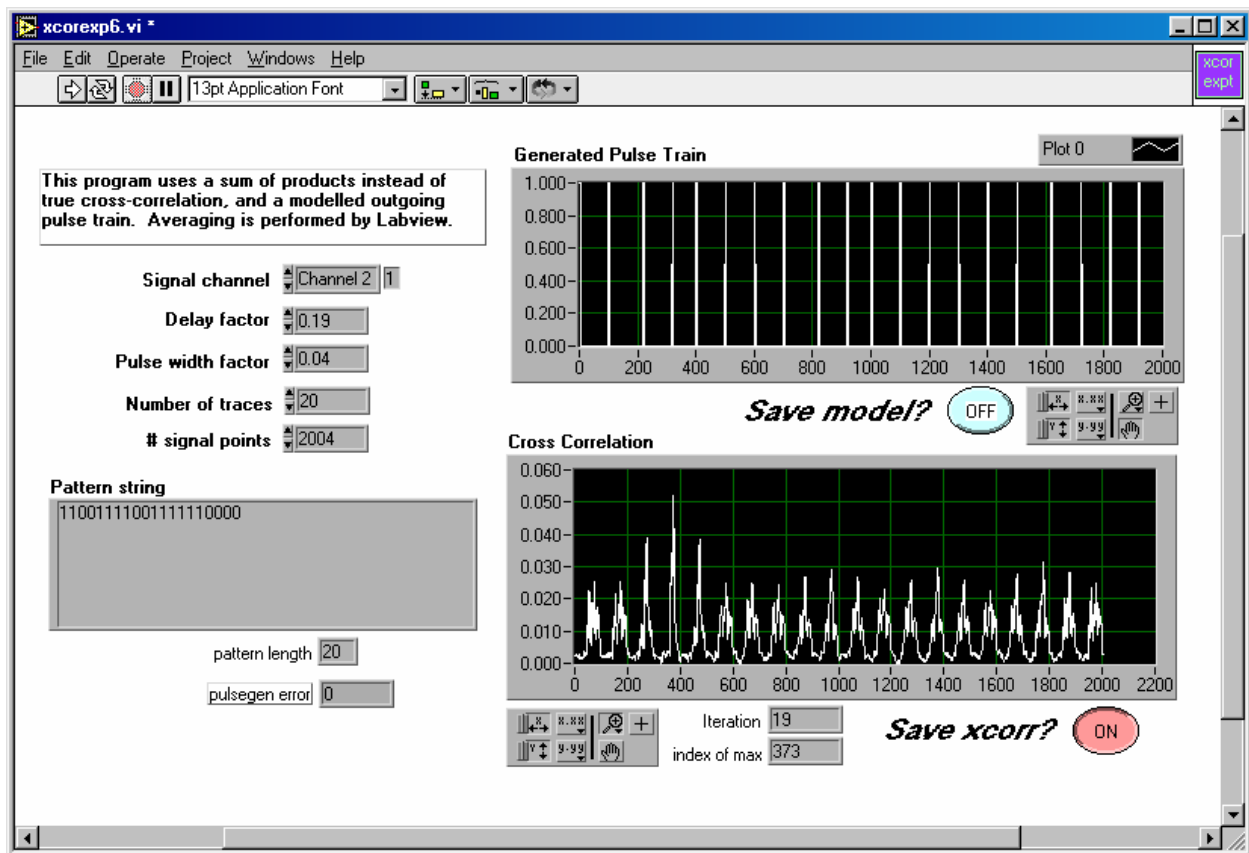

Figure B-1. Front panel screen for data collection and analysis program

The upper plot shows the modelled outgoing pulse train, and the lower plot shows its cross-correlation with the detector signal trace. Below the cross-correlation plot, the number of the current iteration is displayed, along with the index of the maximum. Since the x axis of this plot is in data points, this index gives the data point number of the peak value. Knowledge of the total number of data points and the oscilloscope time scale setting enables straightforward conversion of this axis into units of time. The modelled pulse train and the return signal trace may be saved to text files by turning the “Save?” button on.

Figure B-2 shows the “wiring diagram” or actual code of the program. The pattern generator and oscilloscope are initialized by instrument-specific subroutines in the upper left corner. The loop in the lower left corner converts the pattern code input by the user from a character string to an array of integers. The loop immediately to the right generates the outgoing signal model from this pattern code. The bulk of the work is performed in the large loop at the upper right. First, a signal trace is read from the oscilloscope, then it is cross-correlated with the outgoing signal model. This is done for each iteration of the loop, with the results carried over from one iteration to the next in a running average. Just to the right of this loop, the index, or maximum, of the cross-correlation is determined and the trace is displayed on the front panel. The two small boxes at lower right handle the storage of the displayed plots in data files. Finally, as a convenience for the user, the oscilloscope is returned to local operating mode after the trace is captured, allowing immediate control of the instrument from its front panel.

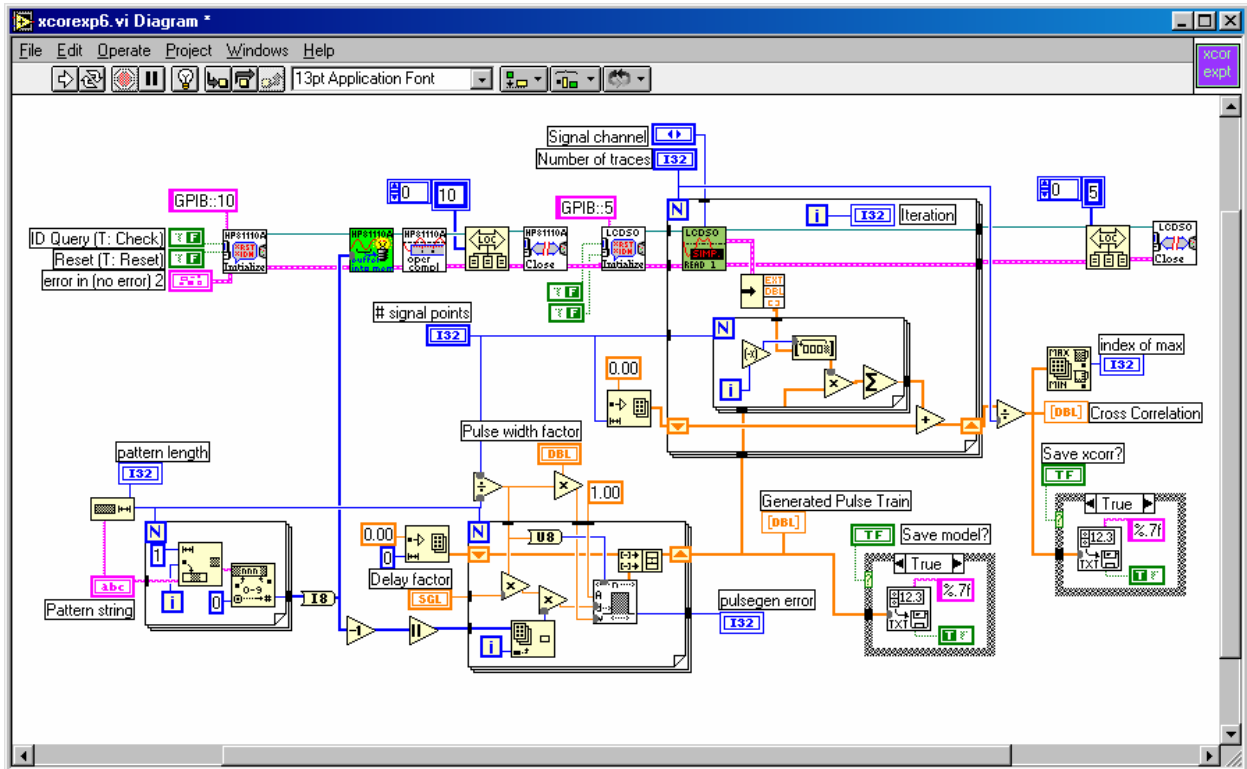

Figure B-2. "Wiring diagram", or code for data collection and analysis program.