

AD _____

Award Number: DAMD17-99-1-9563

TITLE: Multidisciplinary Strategies in the Prevention and Early
Detection of Ovarian Cancer

PRINCIPAL INVESTIGATOR: Samuel C. Mok, Ph.D.

CONTRACTING ORGANIZATION: Brigham and Women's Hospital
Boston, Massachusetts 02115

REPORT DATE: September 2002

TYPE OF REPORT: Annual

PREPARED FOR: U.S. Army Medical Research and Materiel Command
Fort Detrick, Maryland 21702-5012

DISTRIBUTION STATEMENT: Approved for Public Release;
Distribution Unlimited

The views, opinions and/or findings contained in this report are those of the author(s) and should not be construed as an official Department of the Army position, policy or decision unless so designated by other documentation.

20030411 022

REPORT DOCUMENTATION PAGE

Form Approved
OMB No. 074-0188

Public reporting burden for this collection of information is estimated to average 1 hour per response, including the time for reviewing instructions, searching existing data sources, gathering and maintaining the data needed, and completing and reviewing this collection of information. Send comments regarding this burden estimate or any other aspect of this collection of information, including suggestions for reducing this burden to Washington Headquarters Services, Directorate for Information Operations and Reports, 1215 Jefferson Davis Highway, Suite 1204, Arlington, VA 22202-4302, and to the Office of Management and Budget, Paperwork Reduction Project (0704-0188), Washington, DC 20503

1. AGENCY USE ONLY (Leave blank)		2. REPORT DATE September 2002	3. REPORT TYPE AND DATES COVERED Annual (1 Sep 01 -31 Aug 02)	
4. TITLE AND SUBTITLE Multidisciplinary Strategies in the Prevention and Early Detection of Ovarian Cancer			5. FUNDING NUMBERS DAMD17-99-1-9563	
6. AUTHOR(S) Samuel C. Mok, Ph.D.				
7. PERFORMING ORGANIZATION NAME(S) AND ADDRESS(ES) Brigham and Women's Hospital Boston, Massachusetts 02115 E-MAIL: scmok@rics.bwh.harvard.edu			8. PERFORMING ORGANIZATION REPORT NUMBER	
9. SPONSORING / MONITORING AGENCY NAME(S) AND ADDRESS(ES) U.S. Army Medical Research and Materiel Command Fort Detrick, Maryland 21702-5012			10. SPONSORING / MONITORING AGENCY REPORT NUMBER	
11. SUPPLEMENTARY NOTES Original contains color plates: All DTIC reproductions will be in black and white.				
12a. DISTRIBUTION / AVAILABILITY STATEMENT Approved for Public Release; Distribution Unlimited			12b. DISTRIBUTION CODE	
13. ABSTRACT (Maximum 200 Words) none provided				
14. SUBJECT TERMS ovarian cancer			15. NUMBER OF PAGES 167	
			16. PRICE CODE	
17. SECURITY CLASSIFICATION OF REPORT Unclassified	18. SECURITY CLASSIFICATION OF THIS PAGE Unclassified	19. SECURITY CLASSIFICATION OF ABSTRACT Unclassified	20. LIMITATION OF ABSTRACT Unlimited	

NSN 7540-01-280-5500

Standard Form 298 (Rev. 2-89)
Prescribed by ANSI Std. Z39-18
298-102

Table of Contents

Cover.....	1
SF 298.....	2
Table of Contents.....	3
Introduction.....	4-5
Body.....	6-21
Key Research Accomplishments.....	22
Reportable Outcomes.....	23-25
Conclusions.....	25-26
References.....	26
Appendices.....	26

INTRODUCTION

Project 1: Early genetic changes in human epithelial ovarian tumors

Ovarian cancer is the fourth cause of death from all cancers among American women and ranks the highest among deaths from gynecologic malignancies. Although the cure rate with stage I ovarian cancer approaches 90%, two-third of patients are diagnosed with advanced intraperitoneal metastatic disease, with five year survival rate of 15 to 20%. Therefore, it is of paramount importance to identify a marker(s) for early diagnosis of the disease. However, it has been rare to identify Stage I disease and to see transition within a malignant tumor from benign to malignant epithelium which might help us to identify early genetic changes during ovarian cancer development. Recent histologic studies on prophylactic ovaries from high-risk individuals showed the presence of microscopic premalignant and malignant epithelia suggesting that they may create an identifiable milieu from which common epithelial tumors of the ovary will mostly likely arise. Molecular genetic study on these microscopic malignant epithelia would provide us with early genetic events during ovarian cancer development. We therefore propose first, to perform LOH study on specific loci on chromosome 1p, 3p, 5q, 6q, 7q, 9p, 11p, 11q, 12p, 12q, 14q, 17p, 17q, 22q and Xq by polymerase chain reaction (PCR) analysis of tandem repeat polymorphisms; second, to perform immunohistochemistry study on specific oncogene and tumor suppressor genes on paraffin sections prepared from ovaries with microscopic malignant serous lesions and to study specific oncogene activation and tumor suppressor gene inactivation by single strand polymorphism (SSCP) analysis and direct PCR sequencing on microdissected malignant serous epithelium obtained from paraffin-embedded ovaries; and third, to perform RNA fingerprinting on mRNA isolated from microdissected normal and malignant ovarian epithelial cells prepared from normal ovarian surface epithelium and early stage serous ovarian carcinoma and to identify differentially expressed genes in these early stage epithelial ovarian cancer cells. We believe that these studies should provide us with early genetic changes during ovarian cancer progression and serum markers which can be used for early diagnosis of the disease which will significantly improve the survival rate of the patient.

Project 2: A Potential Serum Marker for Ovarian Cancer

The poor prognosis of ovarian cancer is mainly due to the lack of sensitive tests for early detection of the disease, which is often asymptomatic. Studies have shown that ovarian cancer detected in early stage has a high five-year survival rate of exceeding 90%. Therefore, identification of molecular marker for early stage ovarian cancer detection is of paramount importance. This project is to study a cDNA sequence which we have recently identified by differential display. The encoded protein is highly homologous to trypsin and members of the kallikrein protease family. The novel protease, named as protease M, is highly expressed in many invasive epithelial ovarian cancer tissues and cell lines, but not in normal ovarian cell cultures. Since the preliminary data showed that upregulation of protease M was also observed in stage I tumors and the protease was detectable in the conditioned media culturing the tumor cells, the proposed work is to evaluate the potential use of protease M as a serum marker for early detection of ovarian cancer and for monitoring treatment response of ovarian cancer patients, similar to the use of another kallikrein member, prostate-specific antigen (PSA), in the diagnosis and prognosis of prostate cancer. The three objectives of this project are: 1) to study the expression level of protease M in normal human ovaries and ovarian tumors of different stages and histological grades; 2) to characterize protease M and to identify the physiological substrates for protease M by an innovative cyclic peptide library screening method; 3) to develop a sensitive, specific, and reproducible method for measuring the circulating protease M in the sera of ovarian cancer patients. The results of this study will have a

significant impact upon developing a substantially more efficient early detection program with an increased probability of reducing mortality from ovarian cancer. The characterization of protease M protein and identification of physiological substrates for protease M may provide insights into the probable function of this novel protease in the pathogenesis of ovarian cancer. The identified optimal peptide substrates with high specificity and affinity for protease M will have significant value in the development of a carrier for targeted delivery of cytotoxic agents to protease M-secreting ovarian cancer cells.

Project 3: Hormones as etiological factors of ovarian carcinogenesis

Ovarian cancer (OC) is the highest-ranking cause of death from gynecological cancers among American women. All cell types of the human ovary may undergo neoplastic transformation; the vast majority (80-90%) of malignant tumors are derived from the single layer of epithelial cells covering the ovarian surface. Although the etiology of OC is still unknown, several theories have been put forth to explain epidemiologic correlates. Nulliparity, lower number of pregnancies, never breast-feeding, and infertility are linked to increased incidence of ovarian cancer. Since these conditions may increase the number of ovulations in a woman's life-time, a unified hypothesis has been proposed to explain the interrelationships between OC and these contributory factors. It has been postulated that "incessant ovulation" leads to neoplastic transformation of HOSE cells. It is believed that following ovulation, ovarian epithelial cells undergo rapid proliferation to repair the ruptured epithelium. While the etiology of OC remains elusive, epidemiological observations have implicated ovarian steroids and/or gonadotropins, particularly when present at abnormal levels during and after menopause, as probable risk factors of OC. Understanding the role of hormones in ovarian carcinogenesis is of utmost importance to combat this deadly disease.

Project 4: Development of a highly sensitive and specific method for the early detection and a strategy for the early intervention of ovarian cancer

Ovarian carcinoma has the worst prognosis of any gynecological malignancy, due to the difficulty of early detection, the high metastatic potential of the tumor and the lack of highly effective treatment for metastatic disease. We have shown previously that lysophosphatidic acid (LPA) may represent a useful marker for the detection of ovarian cancer (5). The method used for LPA determination was a gas chromatographic method, which is cumbersome to perform. We have proposed to develop a mass spectrometry-based method to detect lysophospholipids in human body fluids (Task 1). This method will then be used to analyze lysolipids in blood samples collected from patients with ovarian cancer, other diseases, or healthy controls to determine whether one or more of these lipids may be useful for the detection of ovarian cancer (Task 1). In Task 2, we hypothesize that elevated levels of LPA in blood and ascites from patients with ovarian cancer are due to an abnormality of LPA production and/or degradation. We propose to study the enzymes controlling levels of LPA in ovarian cancer cells and/or body fluids from patients with ovarian cancer. If an abnormal enzymatic activity associated with ovarian cancer is identified, it may represent a target for early intervention, since LPA is likely to be involved in ovarian tumor cell growth, angiogenesis, and metastasis.

BODY

Project 1: Early genetic changes in human epithelial ovarian tumors

Task 1. Tissue collection, processing and microdissection (months 1-36): A total of 48 stage I epithelial ovarian carcinomas have been collected. Tissue collection will be continued in month 24-36.

Task 2. To perform loss of heterozygosity (LOH) studies on specific loci on chromosome 1p, 3p, 5q, 6q, 7q, 9p, 11p, 11q, 12p, 12q, 14q, 17p, 17q, 22q and Xq in microscopic stage I serous ovarian carcinomas by polymerase chain reaction (PCR) analysis of tandem repeat polymorphisms (months 1-36).

a). Tissue sectioning, and DNA extraction (months 1-12): Tissue sectioning, microdissection, and DNA extraction have been completed.

b). LOH study (months 3-36):

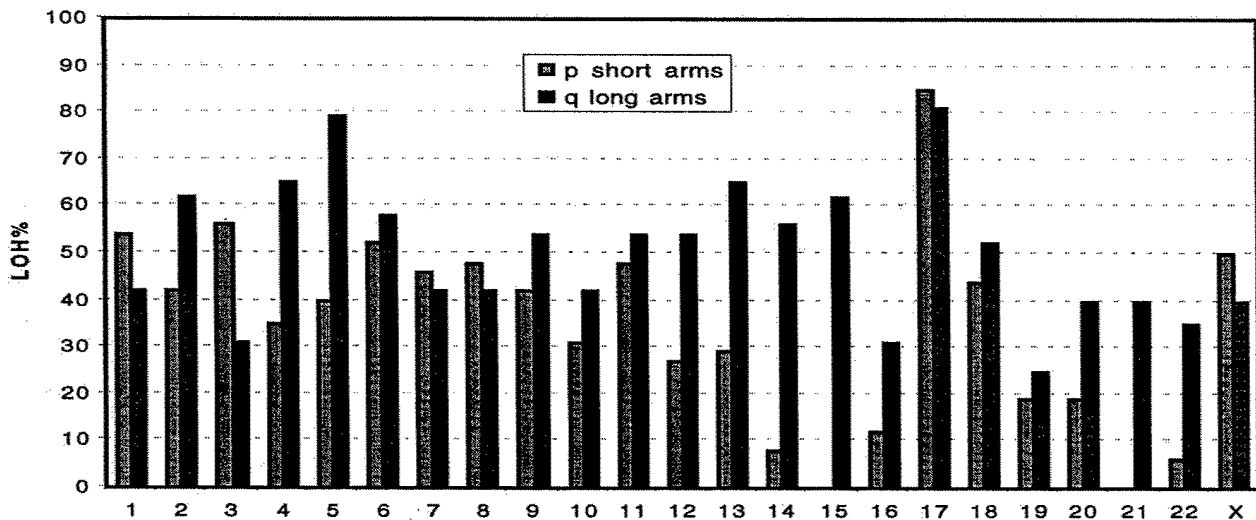

Figure 1. Frequency of loss of heterozygosity at each chromosome arm in 48 cases of stage I ovarian cancer

Using a high-throughput PCR-based method combined with laser capture microdissection and whole genome amplification techniques, we perform allelotyping on DNA isolated from 48 stage I sporadic epithelial ovarian cancer including 15 serous, 9 mucinous, 12 endometrioid, and 12 clear cell carcinomas. Among them, four are microscopically detected tumors. A total of 240 fluorescent-labeled microsatellite markers spanning the whole genome were used. The frequency of loss of heterozygosity (LOH) for each chromosome marker in all 48 cases was calculated (Figure 1). Chromosomal arms showed over 50% LOH rate include 1p, 2q, 3p, 4q, 5q, 6p and 6q, 9q, 11q, 12q, 13q, 14q, 15q, 17p and q, and 18q. Frequencies of LOH at specific loci were also determined and those over 30% were depicted in Table 1. These data indicate that high frequencies of LOH can be identified in multiple chromosomal arms in early stage ovarian cancer. Whether different subtypes of ovarian cancers have different allelic loss patterns is under investigation.

Table 1. Chromosomal regions with incidence (>30%) of LOH in stage I ovarian cancer

Chromosome arm	Markers	Regions	LOH/inf.	LOH%
1p	D1S199	1p36.13	12/36	33
2q	D2S2382	2q34-35	12/35	34
3p	D3S1304	3p25.3-25.2	13/37	35
3p	D3S1300	3p21.1	17/39	44
4q	D4S426	4q35.2	12/34	35
5q	D5S433	5q22	13/38	34
6p	D6S1574	6p24	18/43	42
6q	D6S287	6q21	13/34	38
6q	D6S441	6q24	14/32	44
6q	D6S264	6q25.2	19/32	59
8p	D8S550	8p23.1	10/32	31
8p	D8S258	8p22	12/36	33
9p	D9S288	9p24.1	12/38	31
9q	D9S158	9q34.3	9/27	33
11p	D11S4046	11p15	14/42	33
11p	D11S904	11p14.3	13/40	33
11p	D11S905	11p12	13/37	35
11q	D11S901	11q13.3-14.2	10/30	33
11q	D11S3120	11q24	10/26	38
12q	D12S351	12q21.32	12/34	35
12q	D12S1659	12q24.33	13/35	37
13p	D13S175	13p12-13q11	14/30	47
13q	D13S171	13q12.3	10/29	34
13q	D13S263	13q14.2	17/41	41
13q	D13S265	13q31.1	13/34	38
14q	D14S275	14q11.2	11/31	35
15q	D15S128	15q11.2-12	13/38	34
15q	D15S117	15q21.3	12/36	33
17p	D17S849	17p13.3	17/34	50
17p	D17S831	17p13.3	15/41	36
17p	D17S1828	17p13.1	19/45	42
17p	D17S1876	17p13.1	21/43	49
17p	D17S1791	17p12	14/41	34
17p	D17S799	17p12	19/38	50
17p	D17S921	17p12-q21.2	13/30	43
17p	D17S1857	17p12-q21.2	17/38	45
17p	D17S1824	17p12-q21.2	14/42	33
17q	D17S798	17q21.2	10/28	36
17q	D17S1795	17q21.3-22	13/40	32
17q	D17S787	17q21.3-22	17/38	45
17q	D17S944	17q22	12/27	44
17q	D17S1816	17q22-23	14/37	38
17q	D17S1862	17q24	21/45	47
17q	D17S836	17q25	11/26	42
17q	D17S784	17qter	11/32	34
20q	D20S196	20q13.2-13.31	12/38	31
21q	D21S266	21q22.3	12/33	36

Task 4. To identify differentially expressed genes in microdissected normal ovarian surface epithelial cells and Stage I ovarian carcinoma cells by RNA fingerprinting technique (months 12-36).

Perform RNA fingerprinting (months 12-24)

Characterize differentially expressed sequences (months 16-30) (see attached manuscripts)

1. Kim HK, Skates SJ, Uede T, Wong KK, Schorge JO, Feltmate CM, Berkowitz RS, Cramer DW, Mok SC. Osteopontin as a potential diagnostic biomarker for ovarian cancer. *JAMA* 2002, 287:1671-1679.
2. Wong KK, Cheng RS, Berkowitz RS, Mok SC. Gene expression analysis of ovarian cancer cells by cDNA microarray. In *Microarray and Cancer Research*. Ed. J.A. Warrington, C.R. Todd, and D. Wong. Eaton Publishing, Westboro, MA

Using the MICROMAX cDNA microarray system and RNA isolated from ovarian cancer cell lines and normal ovarian surface epithelial cells (HOSE), we identified a gene called osteopontin that exhibited an ovarian cancer-to-HOSE ratio of 184. For validation studies, real time quantitative PCR analysis and immunohistochemistry were performed in normal and malignant ovarian epithelial cell lines and tissues. To evaluate the potential of osteopontin as a tumor marker, we examined the amount of osteopontin in plasma samples obtained from ovarian cancer cases and controls by an enzyme-linked immunosorbent assay (ELISA). Real time quantitative PCR analysis revealed significant overexpression of osteopontin mRNA in ovarian cancer compared to normal ovaries. Immunolocalization of osteopontin showed that cancer cases expressed higher levels of osteopontin than benign tumors and normal germinal epithelia cases ($p=0.033$), and mucinous subtype of ovarian cancer expressed higher levels of osteopontin than the serous subtype. Osteopontin levels in plasma were significantly higher ($p<0.0001$) in 83 patients with epithelial ovarian cancer (606.3 ng/ml) compared to 207 normal controls (182.8 ng/ml), 36 patients with benign ovarian diseases (309.5 ng/ml), and 48 patients with other gynecologic cancers (412.6 ng/ml). When a single cut off value of 274.5 ng/ml was used, osteopontin showed a sensitivity of 81.4% and a specificity of 88.6%. For the diagnosis of ovarian cancer, osteopontin in combination with CA 125 increased the sensitivity to 97.1% from 87.1% with CA 125 alone ($p=0.04$). This study showed that osteopontin is an ovarian tumor marker with clinical usefulness.

Project 2: A Potential Serum Marker for Ovarian Cancer

Task 1: Investigation of expression of protease M in clinical samples:

1. Collection of samples: months 1 - 30

Samples are continuously collected by Dr. Samuel Mok and his associates.

2. Gene expression study: months 6 - 36

Table 2 summarizes the updated expression data of protease M in ovarian tumor tissues according to different stages of the disease. For the RNA analysis, we have applied real-time quantitative RT-PCR to analyze the expression of protease M in ovarian tumors in comparison with the levels in normal ovarian epithelial primary cultures. Most of the tested tumor RNAs expressed high levels of protease M transcript. Furthermore, many of the early stage and low grade tumor samples showed up-regulation of

protease M expression, suggesting that high levels of protease M expression also occur in stage I tumors, especially for invasive epithelial ovarian cancers. Up-regulation of protease M may be an early event during ovarian carcinogenesis. The data for protein expression was obtained by Western blot analysis. We have developed some monoclonal antibodies and we are in the process of testing them (see Task 3). A good monoclonal antibody specific to protease M will be used in determining the protein levels in archival tissues by immunohistochemical staining.

	INVASIVE		BORDERLINE	
	RNA	PROTEIN	RNA	PROTEIN
Stage 1	8/9 (89%)	4/6 (67%)	3/4 (75%)	0/1 (0%)
Stage 2	4/7 (57%)	0/1 (0%)	5/6 (83%)	2/2 (100%)
Stage 3	29/33 (88%)	10/18 (56%)	2/2 (100%)	N.D.
Stage 4	7/7 (100%)	1/1 (100%)	N.D.	N.D.

Table 2. Protease M expression in different stages of epithelial ovarian tumors.

Percentage of cases that show protease M RNA and/or protein expression are tabulated according to disease stages. N.D. = not determined.

Task 2: Substrate screening:

1. Enzymatic assays for protease M and other proteases: months 8 - 16

We have to produce protease M recombinant protein for the enzymatic assays. In light of this, we have cloned the full-length protease M cDNA into the mammalian inducible expression vector *pcDNA6/TO/myc* (Invitrogen) in frame with the C-terminal hexahistidine (His) and *myc* tags and transfected into ovarian cancer cell line SKOV3, which has a deletion of the gene. Several resultant cell lines (SK-hK6) that can be induced in the presence of tetracycline to produce protease M recombinant protein were isolated (**Figure 2A**). The recombinant protein was also detectable in the conditioned medium. By making use of the C-terminal His-tag, the recombinant protein was purified to near homogeneity from the low-serum conditioned medium by one step ProBond™ nickel affinity chromatographic column (Invitrogen) shown in **Figure 2B**. Before elution, the pro-enzyme was activated by mild trypsin treatment. The column was then extensively washed to remove the trypsin, and the bound proteins were eluted with elution buffers containing increasing concentrations of imidazole. The elution products were concentrated by Centricon centrifugation (Millipore) and protein concentrations were determined. The elution products were tested for protease activity using a commercially available kit (**Figure 2C**). Measurable protease activity was detected with the recombinant protein purified from tetracycline-induced conditioned medium. A control sample prepared from uninduced conditioned medium and was similarly treated with trypsin did not show any protease activity.

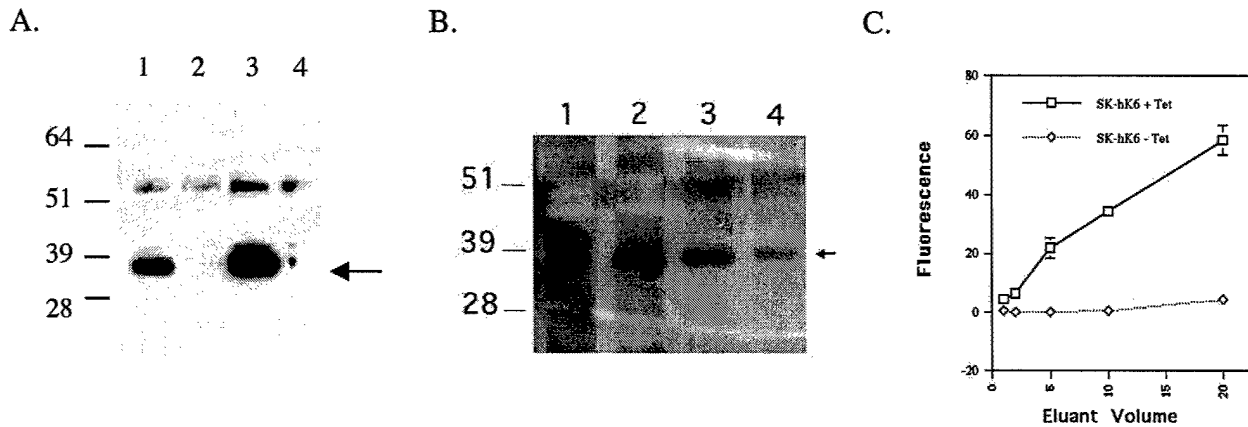

Fig. 2. Production of protease M recombinant protein.

- A. Western blot analysis of SK-hK6 subclones. Shown are two clones that are inducible for the expression of protease M. Lanes 1 and 2 belong to one clone, and lanes 3 and 4 belong to the other clone. Lanes 1 and 3 were cell lysates extracted from cells treated with tetracycline, whereas lanes 2 and 4 were from uninduced cells. The protease M bands are marked by an arrow.
- B. A silver-stained SDS-PAGE gel of bound proteins eluted with different concentrations of imidazole: lane 1: 50 mM; lane 2: 200 mM; lane 3: 350 mM; and lane 4: 500 mM. The recombinant proteins are marked by an arrow.
- C. Proteolytic assay using an EnzChek™ Protease Assay Kit (Molecular Probes). Proteolytic activity of the recombinant protease M protein eluted with 350 mM imidazole released the highly fluorescent BODIPY FL dye-labeled peptides. The plot shown is arbitrary fluorescence units versus eluant volumes (μl).

We have also analyzed the recombinant protein by a biotinylated fluorophosphonate (FP-biotin) probe. The FP-biotin probe was developed by one of our collaborators, Dr. Benjamin Cravatt of the Scripps Research Institute (5). FP is a potent and specific inhibitor of serine hydrolases including serine proteases. The reactivity of FP with serine hydrolases requires that the enzymes be in a catalytically active state. Hence, a FP linked to a small molecule reporter group (biotin) can serve as a potent and selective probe for monitoring simultaneously the activities of multiple serine proteases. The preparations shown in **Fig. 3A** contained in addition to the protease M protein also some other contaminating proteins. Nevertheless, the impurities did not affect the enzyme activity shown in **Fig. 3B**. Pretreatment with 500 nM of trypsin over-digested the protein (**Fig. 3A**, lane 2). The same procedure applied to control medium did not result in any protein collection (**Fig. 3A**, lanes 3 and 4). The protein preparations were then incubated with FP-biotin probe for half an hour at 25 °C. The reactions were then quenched by adding standard 2x SDS/PAGE loading buffer and run on a SDS/PAGE gel. The separated proteins were electroblotted onto a PVDF membrane, and treated with an avidin-horseradish peroxidase conjugate (Pierce) and detected by SuperSignal chemiluminescence reagents (Pierce).

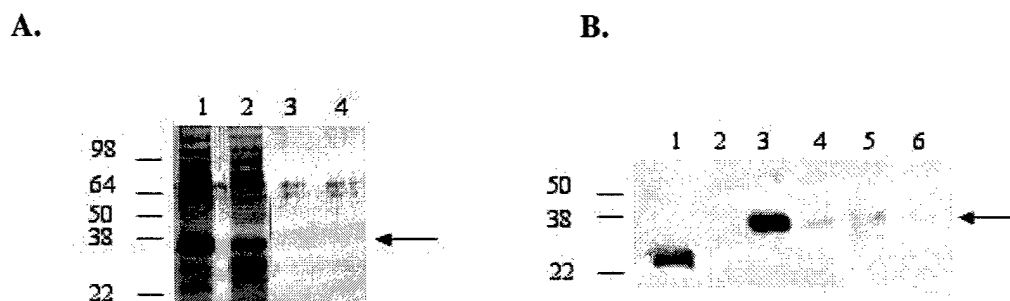

Fig. 3. Enzymatic activity assay using FP-biotin probe.

A. Purification of protease M recombinant protein from culture medium using nickel column chromatography and activation by trypsin treatment. Lane 1 and lane 2: preparations from spent medium with cells induced to secrete protease M, lanes 3 and 4: preparation from spent medium with cells without induction. Lanes 1 and 3: treatment with 50 nM of trypsin; lanes 2 and 4: treatment with 500 nM of trypsin. The protease M band was indicated by an arrow.

B. FP-biotin reactions. Lanes 1 and 2: reactions with trypsin as controls. Lanes 3 and 4: reactions with preparation activated by 50 nM trypsin treatment. Lanes 5 and 6: reactions with preparations treated with 500 nM of trypsin. Lanes 2, 4, and 6 were reactions with pretreatments with heating at 80°C. The protease M band was indicated by an arrow.

As shown in **Fig. 3B**, minor treatment of protease M recombinant proenzyme with trypsin activated protease M activity towards the FP-biotin probe (lane 3). The activity was drastically reduced by preheating the sample at 80°C for 5 min (**Fig. 3B**, lane 4). The activity observed was from the protease M protein, and not from any residual trypsin from the proenzyme activation step (the protease M band can be distinguished from trypsin because of their size difference, as shown in **Fig. 3B**, lane 1 and lane 3). Overdigestion by trypsin (**Fig. 3A**, lane 2) resulted in little enzyme activity (**Fig. 3B**, lanes 5 and 6).

2. Enzymatic assays in the presence of protease inhibitors: months 16 - 20

In progress.

3. Peptide library screening: months 14 - 24

We have given our protein samples to our collaborator, Dr. Ben Turk of Beth Israel Deaconess Medical Center. We hope that we can have the results soon.

4. Confirmation of the optimal peptide motifs by enzymatic assays: months 25 - 30

Not started yet.

Task 3: Detection of protease M in patient blood:

1. Collection of samples and storage: months 1 - 24

Samples are continuously collected by Drs. Samuel Mok and Dan Cramer.

2. Development of detection methods: months 6 - 24

We have prepared and purified protease M recombinant protein fused with maltose-binding protein (MBP). With the expertise help from Drs. Rebecca Hussey and Yunmei Wang of Dana-Farber/Harvard Cancer Center, we have immunized five BalB/C mice with purified protein preparations. Spleen cells harvested from a mouse were fused with the myeloma cell line NS1. About 1000 fusion clones were screened by enzyme-linked immunosorbent assay (ELISA) with MBP-PM fusion protein and MBP control, and by Western blot analysis with GST-PM *E. coli* lysates. About ten clones were identified that are specific to protease M protein and do not show cross-reaction to trypsin and other kallikrein proteins such as hK1 and hK3. These monoclonal antibodies will be characterized, particularly for the use in immunohistochemical staining and serum screening.

3. Assays on the blood samples: months 25 - 30

• Not started yet.

4. Data analysis: months 31 - 36

Not started yet.

Project 3: Hormones as etiological factors of ovarian carcinogenesis

The first objective is to determine the efficacies of selected estrogens, to achieve this the HOSE cells will be treated with increasing concentrations of estrogen for five days. The cell proliferation will be measured by MTT assay. To study the synergistic effect of FSH and estrogens cells will be cultured in the absence or presence of FSH and HOSE cell proliferation will be studied. To ascertain whether their mitogenicities are mediated via estrogen receptors receptor blocker will be used.

The second objective is to determine whether the 3 selected estrogens have direct oncogenic potentials and if they could be enhanced by FSH and blocked by the antiestrogen, ICI 182, 780. The HOSE cells will be plated and exposed to different doses of estrogen for two weeks. Soft agar assay will be used to study the transformation potential of estrogens. In a parallel experiment FSH will be added along with estrogen to study the synergistic effect on cell transformation.

The third objective is to pick up a hormonal milieu that will produce the highest frequency of *in vitro* transformation. To ascertain whether progesterone and DHEA exert anti-tumorigenic action by blocking the estrogen and/or FSH-induced neoplastic transformation of HOSE cells, *in vitro* transformation assay will be used to assay the ability of progesterone and DHEA in inhibiting the estrogen-gonadotropin-induced transformation of HOSE cells.

We have established an assay to evaluate the effect of various hormones on the growth of HOSE cells *in vitro* and demonstrated that estradiol significantly stimulated the HOSE cell proliferation. The HOSE primary (HOSE 639, HOSE 770, HOSE 783, HOSE 785) and immortalized (HOSE 642, HOSE 301, HOSE 306, HOSE 12-12) cell lines were cultured in Medium 199 (phenol red-free) MC DB 105 (1:1) supplemented with 1% L-glutamine, 10% fetal calf serum, penicillin (100 units/ml) and streptomycin (100 µg/ml), when reached 80% confluence were harvested and washed twice in PBS and then seeded at a density of 1000 cells/ well in 96-well plates. Cultures were maintained in above mentioned medium except fetal calf serum was stripped twice with charcoal (this is very important for removing all sex steroids). Forty-eight hours after cell plating, the medium will be replaced with the same medium containing various doses of (10^{-11} - 10^{-6} M) estradiol or estrone (E2, E1, Sigma, St. Louis, MO). Steroids (E1, and E2) were dissolved in absolute ethanol. The final concentration of ethanol in the medium was 0.1%. The control cells were exposed to equal concentrations of ethanol vehicle without test substance. The cells were treated for 5 days with hormones. In a parallel set of experiment primary and immortalized HOSE were cultured with various concentration of estradiol (10^{-11} - 10^{-6} M) and 10^{-4} M follicle-stimulating hormone (FSH, Calbiochem, San Diego, CA) for 5 days. On day 6 of culture, cell proliferation was measured by a Boehringer Mannheim cell proliferation kit (MTT). After the incubation period, 10 µl of the MTT labeling reagent (final concentration 0.5 mg/ml) was added to each well and plates were incubated for four hour in a humidified atmosphere. Finally 100 µl of a solubilization solution was added to each well and plates were incubated overnight in 37°C.

Cell growth was measured based on the cellular conversion of a tetrazolium compound into a colored formazan product. The absorbance was measured at 570 nm in a spectrophotometer to determine the cell number in each well. Results are expressed by giving one arbitrary unit for the absorbance of cells in nontreated wells. Absorbance for wells not exposed to hormones was arbitrarily set as 1 and absorbance in hormone treated wells expressed as fold increase of the untreated controls. To study whether the proliferative effects of estradiol on HOSE cells are receptor mediated, the primary and immortalized cells were cultured with estradiol (10^{-4} M) in the presence or absence of two doses (10^{-4} and 10^{-3} M) of pure antiestrogen ICI for five days. On day 6 cells were counted. Arbitrary unit of one was assigned to number of cells in controls and fold increase in cell number was calculated in treated cells.

Estradiol stimulated cell proliferation is inhibited by antiestrogen

When increasing concentrations (10^{-11} - 10^{-6} M) of estrone (E1) or estradiol (E2) were added to primary HOSE 639, HOSE 770, HOSE 783, HOSE 785 (Fig 1), and immortalized normal HOSE 642, HOSE 301, HOSE 306, HOSE 12-12 (Fig 4), in culture, a dose dependent rise in cell proliferation was observed. About ten to fourteen fold increase was noted by 10^{-6} M E1 or E2 in HOSE 639, HOSE 770, HOSE 783, HOSE 785 cell

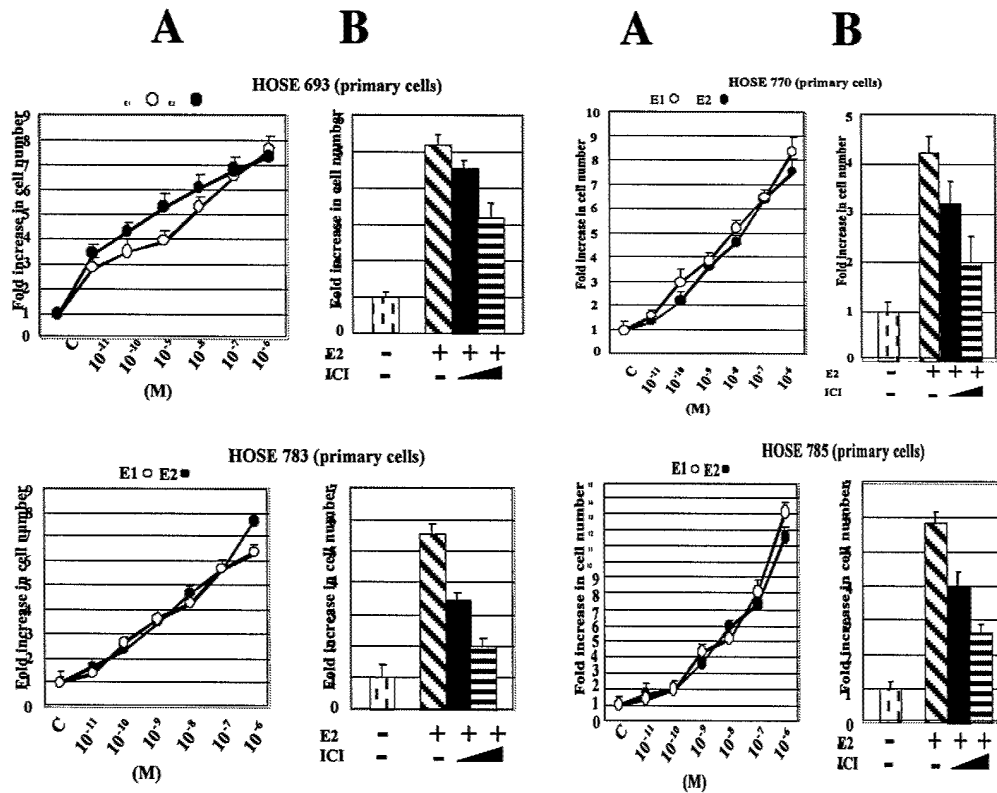

FIG 4 Effect of estradiol and estrone on cell proliferation in normal primary OSE cells. HOSE cells HOSE 693, HOSE 770, HOSE 783 and HOSE 785 cells were cultured at the density of (A) 1000 cells/well in 96 well plate in medium 199:MCDB 105 supplemented with 10%FBS (heat inactivated charcoal striped FBS), 100 U/ml penicillin-streptomycin for MTT assay. After pre-incubation for 48 hours, the cells were treated with different concentrations (10^{-11} - 10^{-6} M) of estradiol (solid circle) or estrone (open circle) for 5 days. The cell growth was assessed by MTT assay as described in Material and Methods. Absorbance of wells not exposed to hormones was arbitrarily set as 1 and estradiol and estrone treated cell growth was expressed as fold increase of control. (B) To confirm the specificity of estradiol 2

$\times 10^5$ cells per T-25 flask were cultured alone (hatched bar) or co-treated with 10^{-8} M of estradiol (hatched diagonal) and two doses of ICI (10^{-5} black, and 10^{-4} M horizontal hatched) for 5 days. The control cells were treated with vehicle. After 5 days number of cells were counted. Treatment of cells with estradiol and estrone induced proliferation of cells in a dose-dependent manner. Co-treatment with ICI abolished the response of normal HOSE cells to estradiol. The data is shown as a mean of two experiments with triplicate samples and are represented as mean \pm SD.

lines compared to six fold increase in normal immortalized lines HOSE 642, HOSE 301, HOSE 306 and HOSE 12-12 cell lines. E1 and E2 were equally effective in causing cell proliferation in all cell lines except HOSE 12-12 cell line where E1 showed a significant enhancement of cell proliferation compared to E2. The ICI considered as pure antiestrogen, functions specifically by binding to and inactivating the estrogen receptor. When primary and immortalized HOSE cells were incubated with 10^{-8} M E2 A marked enhancement of cell proliferation was seen in all the cell lines with E2 and when cells were cultured with E2 and two doses (10^{-5} and 10^{-4} M) of ICI for 5 days, addition of ICI to cultures along with E2 markedly attenuated cell proliferation. Cell lines cultured with FSH and estradiol showed significant cell growth but no additive effect was seen in any cell line tested (results not shown).

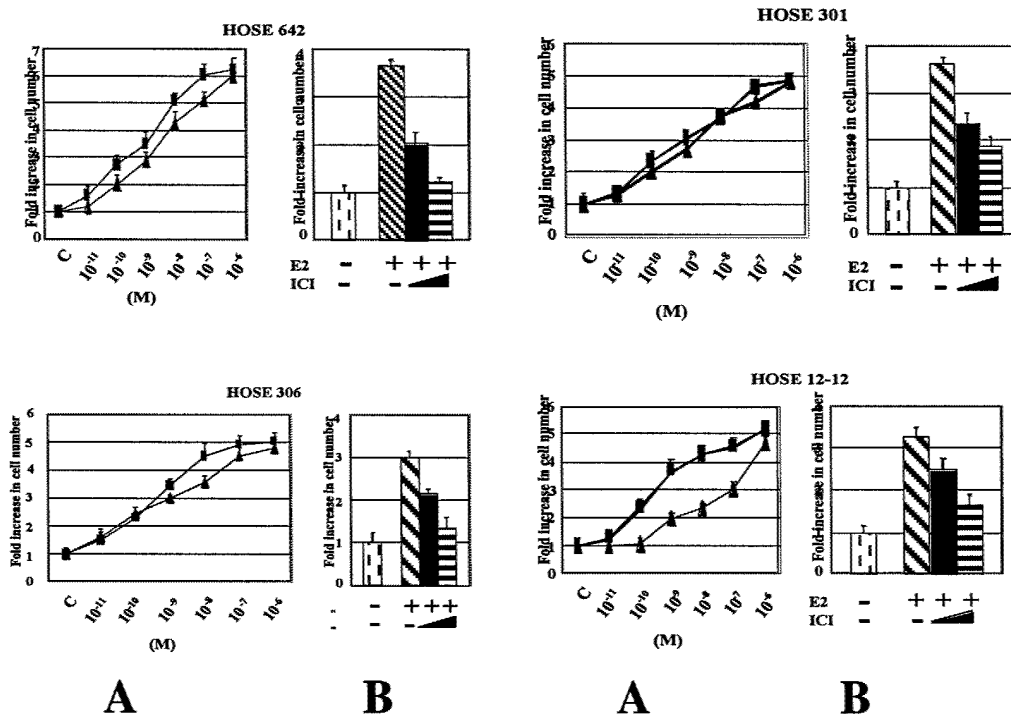

FIG 5 Effect of estradiol and estrone on cell proliferation in normal OSE cell lines. HOSE cell lines HOSE, 642, HOSE 301, HOSE 306 and HOSE 12-12 were cultured at the density of (A) 1000 cells/well in 96 well plate in medium 199:MCDB 105 supplemented with 10%FBS (heat inactivated charcoal striped FBS), 100 U/ml penicillin-streptomycin for MTT assay. After pre-incubation for 48 hours, the cells were treated with different concentrations (10^{-11} - 10^{-6} M) of estradiol (solid triangle) or estrone (solid rectangular) for 5 days. The cell growth was assessed by MTT assay as described in Material and Methods. Absorbance of wells not exposed to hormones was arbitrarily set as 1 and estradiol and estrone treated cell growth was expressed as fold increase of control. (B) To confirm the specificity of estradiol 2×10^5 cells per T-25 flask were cultured alone (hatched bar) or co-treated with 10^{-8} M of estradiol (hatched diagonal) and two doses of ICI (10^{-5} black, and 10^{-4} M horizontal hatched) for 5 days. The control cells were treated with vehicle. After 5 days number of cells were counted. Treatment of cells with estradiol and estrone induced proliferation of cells in a dose-dependent manner. Co-treatment with ICI abolished the response of normal HOSE cells to estradiol. The data is shown as a mean of two experiments with triplicate samples and are represented as mean \pm SD.

Estradiol stimulated cell proliferation is inhibited by antiestrogen

When increasing concentrations (10^{-11} - 10^{-6} M) of estrone (E1) or estradiol (E2) were added to primary HOSE 639, HOSE 770, HOSE 783, HOSE 785, and immortalized normal HOSE 642, HOSE 301, HOSE 306, HOSE 12-12, in culture, a dose dependent rise in cell proliferation was observed. About ten to fourteen fold increase was noted by 10^{-6} M E1 or E2 in HOSE 639, HOSE 770, HOSE 783, HOSE 785 cell lines compared to six fold increase in normal immortalized lines HOSE 642, HOSE 301, HOSE 306 and HOSE 12-12 cell lines. E1 and E2 were equally effective in causing cell proliferation in all cell lines except HOSE 12-12 cell line where E1 showed a significant enhancement of cell proliferation compared to E2. Cell lines cultured with FSH and estradiol showed significant cell growth but no additive effect was seen in any cell line tested. The ICI considered as pure antiestrogen, functions specifically by binding to and inactivating the estrogen receptor. When primary and immortalized HOSE cells were incubated with 10^{-8} M E2 A marked enhancement of cell proliferation was seen in all the cell lines with E2 and when cells were cultured with E2 and two doses (10^{-5} and 10^{-4} M) of ICI for 5 days, addition of ICI to cultures along with E2 markedly attenuated cell proliferation.

Project 4: Development of a highly sensitive and specific method for the early detection and a strategy for the early intervention of ovarian cancer

Task 1. Develop a highly sensitive and specific method for the early detection of ovarian cancer, Months 1-36

Task 2. Develop a strategy for the early intervention of ovarian cancer, Months 1-36

Work accomplished as proposed in Task 1 in the last year

We have completed lipid analyses in 23 patients with ovarian cancer, 9 patients with breast cancer, and 23 healthy controls.

Summary Statistics

Table 1 summarizes the various lipid markers assayed and compares levels obtained from ovarian cancer patients to levels in patients with breast cancer and healthy subjects using the Wilcoxon rank sum test. The markers that are statistically significantly different between groups at the $p < .01$ level are flagged in the last column. As can be seen from this table ovarian cancer patients and non-ovarian cancer patients differ with respect to all markers except S1P, LPAF, the saturated species of LPC (LPC 16:0 and LPC 18:0), and most of the LPC-based ratios.

Correlations

Table 3 summarizes qualitatively the correlations between the various species totals. Combining all patients, alkenyl LPA, alkyl LPA, and LPA are all positively correlated with each other, as are LPI and LPA and LPC and LPAF (Pearson correlations).

Discrimination

Considering the markers listed in Table 3 separately, Table 5 summarizes the sensitivity and specificity at empirically defined "optimum" cut points (i.e. the cut points that maximize sensitivity and specificity) for those markers found to be statistically significantly different between the groups at $p < .01$. Cut points that result in $>90\%$ sensitivity and specificity, respectively, are highlighted in a bold, italic font. For ovarian cancer "regular" LPA and total LPA (all sources) appear to have good discriminatory power. For example, using a cutoff of 1.0 for total "regular" LPA results in 91% sensitivity (2 ovarian cancers are misclassified) and 100% specificity (no breast cancer patient or healthy control had a "regular" LPA >1.0). Similar results are obtained with respect to the saturated portion of "regular" LPA using a cutoff of 0.77. It should be noted, however, that sensitivity and specificity are highly dependent on the cutoff chosen. For example, changing the cutoff for saturated LPA from 0.77 to 0.75 reduces the specificity from 100% to 94%. Using multivariable logistic regression models and discriminate analysis these markers can be combined in various ways to potentially improve upon the sensitivity and specificity. Figures 6 summarizes these results graphically.

Table 3. Summary Statistics

Marker	Ovarian Cancer (n=23)			Breast Cancer (n=9)			Healthy Controls (n=23)			p ¹
	Mean ± s.d.	Median	Range	Mean ± s.d.	Median	Range	Mean ± s.d.	Median	Range	
<u>SIP</u>	0.15 ± 0.15	0.11	0-0.69	0.13 ± 0.15	0.02	0-0.38	0.06 ± 0.04	0.05	0-0.13	
16:0 Alkenyl LPA	0.03 ± 0.04	0.02	0-0.16	0.01 ± 0.01	0.01	0.003-0.02	0.02 ± 0.03	0.01	0-0.11	
18:0 Alkenyl LPA	0.07 ± 0.07	0.04	0.002-0.26	0.01 ± 0.01	0.01	0-0.04	0.03 ± 0.05	0.01	0.001-0.19	
Total Alkenyl LPA	0.10 ± 0.10	0.06	0.003-0.42	0.02 ± 0.01	0.02	0.01-0.05	0.04 ± 0.07	0.02	0.01-0.29	
16:0 Alkyl LPA	0.10 ± 0.10	0.09	0-0.42	0.03 ± 0.03	0.01	0.003-0.07	0.04 ± 0.08	0.02	0-0.32	
18:0 Alkyl LPA	0.06 ± 0.05	0.06	0-0.19	0.01 ± 0.01	0.01	0.001-0.04	0.02 ± 0.03	0.01	0-0.11	
Total Alkyl LPA	0.16 ± 0.15	0.18	0-0.62	0.04 ± 0.04	0.02	0.01-0.10	0.06 ± 0.10	0.03	0.004-0.42	
Alkyl+Alkenyl LPA	0.26 ± 0.24	0.29	0.01-1.04	0.07 ± 0.05	0.03	0.02-0.14	0.10 ± 0.18	0.05	0.02-0.72	
16:0 LPA	1.57 ± 1.40	1.06	0.47-6.60	0.11 ± 0.09	0.07	0.01-0.26	0.17 ± 0.20	0.08	0-0.61	
18:0 LPA	0.61 ± 0.50	0.41	0.08-1.93	0.04 ± 0.03	0.02	0.005-0.10	0.07 ± 0.07	0.04	0-0.23	
Total Saturated	2.17 ± 1.86	1.76	0.56-8.53	0.14 ± 0.12	0.08	0.02-0.32	0.24 ± 0.26	0.10	0-0.77	
18:1 LPA	0.39 ± 0.39	0.30	0-1.77	0.03 ± 0.03	0.02	0.004-0.08	0.03 ± 0.02	0.02	0-0.08	
18:2 LPA	0.31 ± 0.32	0.17	0.01-1.10	0.04 ± 0.03	0.04	0.004-0.09	0.08 ± 0.07	0.04	0-0.25	
20:4 LPA	0.22 ± 0.19	0.13	0.01-0.68	0.02 ± 0.02	0.02	0.001-0.05	0.05 ± 0.05	0.05	0-0.17	
22:6 LPA	0.14 ± 0.14	0.09	0.006-0.42	0.02 ± 0.01	0.01	0.001-0.04	0.01 ± 0.01	0.01	0-0.03	
Total Unsaturated	1.05 ± 0.89	0.64	0.13-3.86	0.11 ± 0.09	0.10	0.02-0.26	0.17 ± 0.09	0.17	0-0.40	
Total "Reg." LPA	3.23 ± 2.52	2.95	0.69-12.38	0.25 ± 0.21	0.18	0.03-0.57	0.42 ± 0.28	0.30	0.06-0.95	
Unsat.:Sat. Ratio ³	0.37 ± 0.21	0.45	0.10-0.92	0.80 ± 0.25	0.71	0.50-1.22	1.84 ± 1.97	1.41	0.23-6.96	
LPA - All Sources	3.49 ± 2.53	3.10	0.80-12.50	0.32 ± 0.26	0.20	0.06-0.70	0.52 ± 0.43	0.32	0.11-1.65	
Unsat.:Sat. Ratio	0.47 ± 0.28	0.32	0.08-1.06	0.52 ± 0.17	0.49	0.34-0.94	1.57 ± 2.28	0.90	0-10.30	
16:0 LPI	0.57 ± 0.69	0.28	0-2.84	0.05 ± 0.03	0.04	0.03-0.13	0.10 ± 0.04	0.09	0.03-0.19	
18:0 LPI	2.09 ± 3.63	0.73	0-14.58	0.15 ± 0.09	0.12	0.04-0.33	0.37 ± 0.14	0.39	0.13-0.66	
Total Saturated	2.66 ± 4.27	1.02	0-17.41	0.20 ± 0.12	0.16	0.08-0.46	0.47 ± 0.18	0.49	0.16-0.85	

Marker	Ovarian Cancer (n=23)			Breast Cancer (n=9)			Healthy Controls (n=23)			p ¹
	Mean ± s.d.	Median	Range	Mean ± s.d.	Median	Range	Mean ± s.d.	Median	Range	
20:4 LPI	0.28 ± 0.28	0.19	0-0.89	0.10 ± 0.09	0.07	0.004-0.31	0.18 ± 0.14	0.20	0.01-0.49	
Total LPI	2.94 ± 4.34	1.47	0-17.74	0.31 ± 0.21	0.24	0.08-0.77	0.65 ± 0.27	0.65	0.17-1.34	
16:0 LPC	24.6 ± 15.3	20.7	5.9-64.5	44.3 ± 7.3	45.5	29.8-53.3	28.6 ± 16.1	28.7	10.2-63.8	
18:0 LPC	8.9 ± 6.4	6.4	2.0-24.7	12.8 ± 2.1	12.2	8.7-15.3	9.1 ± 4.4	7.7	0.54-16.2	
Total Saturated	34.1 ± 22.1	28.4	8.1-93.2	57.5 ± 8.4	58.3	38.7-65.8	38.1 ± 20.1	36.5	13.3-74.9	
18:1 LPC	5.7 ± 5.6	4.5	0-23.2	15.0 ± 3.4	15.5	7.9-20.5	10.9 ± 8.6	9.6	0.2-27.7	
18:2 LPC	4.2 ± 3.1	2.9	0.1-10.8	21.8 ± 5.3	22.5	12.5-30.8	18.4 ± 15.4	16.6	0.1-43.4	
20:4 LPC	2.8 ± 3.3	1.1	0-9.9	15.3 ± 3.6	15.0	9.6-20.7	9.8 ± 9.5	9.9	0.1-36.1	
Total Unsaturated	15.0 ± 11.2	13.5	1.4-38.7	61.6 ± 12.7	58.1	40.2-87.2	44.0 ± 35.8	49.6	0.8-108.6	
Total LPC	49.1 ± 29.4	36.7	11.1-127.6	119.0 ± 18.8	123.0	78.8-150.2	82.1 ± 54.3	91.1	16.0-166.5	
Unsat.:Sat. Ratio	0.51 ± 0.44	0.38	0.06-1.98	1.07 ± 0.18	1.04	0.88-1.38	1.00 ± 0.68	1.12	0.05-2.41	
16:0 to 18:2 Ratio	17.57 ± 37.64	5.89	1.50-181.29	2.10 ± 0.39	2.19	1.41-2.66	16.54 ± 43.84	1.78	0.77-155.44	
16:0 to 18:1 Ratio ⁴	8.83 ± 15.86	3.74	1.73-71.59	3.04 ± 0.57	3.01	2.33-3.94	9.30 ± 19.90	2.98	1.69-79.16	
16:0 to 18:0 Ratio	2.98 ± 0.81	2.77	1.75-4.61	3.51 ± 0.64	3.38	2.54-4.47	4.12 ± 4.58	2.88	1.70-23.54	
16:0 to 20:4 Ratio ⁵	38.11 ± 57.25	13.09	1.26-208.81	3.04 ± 0.87	2.58	2.12-4.74	17.23 ± 23.75	3.82	1.21-81.32	
16:0 to 22:6 Ratio	18.15 ± 15.03	11.59	2.37-62.15	5.24 ± 1.85	4.73	2.45-7.85	15.85 ± 15.16	7.72	2.25-58.47	
18:0 to 18:2 Ratio	6.43 ± 13.33	2.24	0.35-63.59	0.61 ± 0.13	0.55	0.47-0.90	8.18 ± 22.82	0.50	0.03-91.02	
L-PAF	0.14 ± 0.13	0.10	0.02-0.54	0.31 ± 0.10	0.27	0.18-0.49	0.14 ± 0.08	0.13	0.03-0.29	

¹ Difference between breast cancer patients and healthy controls is statistically significant at p<.01 (Wilcoxon rank sum test)

² Difference between ovarian cancer patients and healthy controls/breast cancers is statistically significant at p<.01 (Wilcoxon rank sum test)

³ n=21 control patients with "Regular" saturated LPA>0

⁴ n=19 ovarian cancer patients with LPC 18:1>0

⁵ n=22 ovarian cancer patients with LPC 20:4>0

⁶ Healthy controls versus breast cancer patients

⁷ Ovarian cancer patients versus controls plus breast cancer patients

Table 4. All Patients (n=55)

	LPC	LPAF	LPI	Total LPA ²	Reg. LPA	Alkenyl LPA	Alkyl LPA	SIP
SIP	no	no	Yes (+)	no	no	no	no	
Alkyl LPA	Yes (-)	<i>p</i> = .01 (-)	no	Yes (+)	no	Yes (+)		
Alkenyl LPA	Yes (-)	no	no	Yes (+)	no			
Reg. LPA	<i>p</i> = .01 (-)	no	Yes (+)	Yes (+)				
Total LPA ²	Yes (-)	no	Yes (+)					
LPI	no	no						
LPAF	Yes (+)							
16:0 to 18:0	no	no	no	no	no	no	no	no
16:0 to 18:1 ³	Yes (-)	no	no	no	no	Yes (+)	Yes (+)	no
16:0 to 18:2	<i>p</i> = .01 (-)	no	no	no	no	Yes (+)	Yes (+)	no
16:0 to 20:4 ⁴	no	no	no	no	no	no	no	no
16:0 to 22:6	Yes (-)	Yes (-)	no	no	no	Yes (+)	Yes (+)	no
18:0 to 18:2	<i>p</i> = .01 (-)	no	no	no	no	Yes (+)	Yes (+)	no

¹ "Yes" indicates the Pearson correlation is statistically significantly different from 0 at *p* < .01

² LPA from all sources - alkyl+alkenyl+"regular" LPA

"+" indicates a positive correlation and "-" indicates an inverse relationship

³ n=51 subjects with LPC 18:1>0

⁴ n=54 subjects with LPC 20:4>0

Table 5. Cutpoints for Classifying Ovarian Cancer

	Cut Point	Sensitivity	Specificity
18:0 Alkenyl LPA	>0.03	61%	84%
Total Alkenyl LPA	>0.035	65%	84%
16:0 Alkyl LPA	>0.04	65%	81%
Total Alkyl LPA	>0.06	65%	81%
Alkyl+Alkenyl LPA	>0.10	70%	81%
16:0 LPA	>0.62	91%	97%
18:0 LPA	>0.20	91%	97%
Total Saturated	>0.77	91%	100%
18:1 LPA	>0.10	78%	100%
18:2 LPA	>0.16	52%	94%
20:4 LPA	>0.11	70%	91%
22:6 LPA	>0.05	65%	100%
Total Unsaturated	>0.40	83%	97%
Total "Reg." LPA	>1.0	91%	100%
Unsat.:Sat. Ratio³	<0.71	35%	81%
LPA – All Sources	>1.6	91%	97%
16:0 LPI	>0.11	78%	91%
18:0 LPI	>0.50	78%	91%
Total Saturated	>0.65	78%	94%
Total LPI	>1.0	70%	97%
18:1 LPC	<6.5	65%	72%
18:2 LPC	<12.0	100%	72%
20:4 LPC	<5.0	78%	72%
Total Unsaturated	<30.0	87%	72%
Total LPC	<75.0	78%	66%
Unsat.:Sat. Ratio	<0.85	87%	72%
16:0 to 18:2 Ratio	>2.7	87%	75%
16:0 to 20:4 Ratio	>4.0	77%	66%
18:0 to 18:2 Ratio	>1.37	70%	75%

Figure 6 Total "Regular" LPA

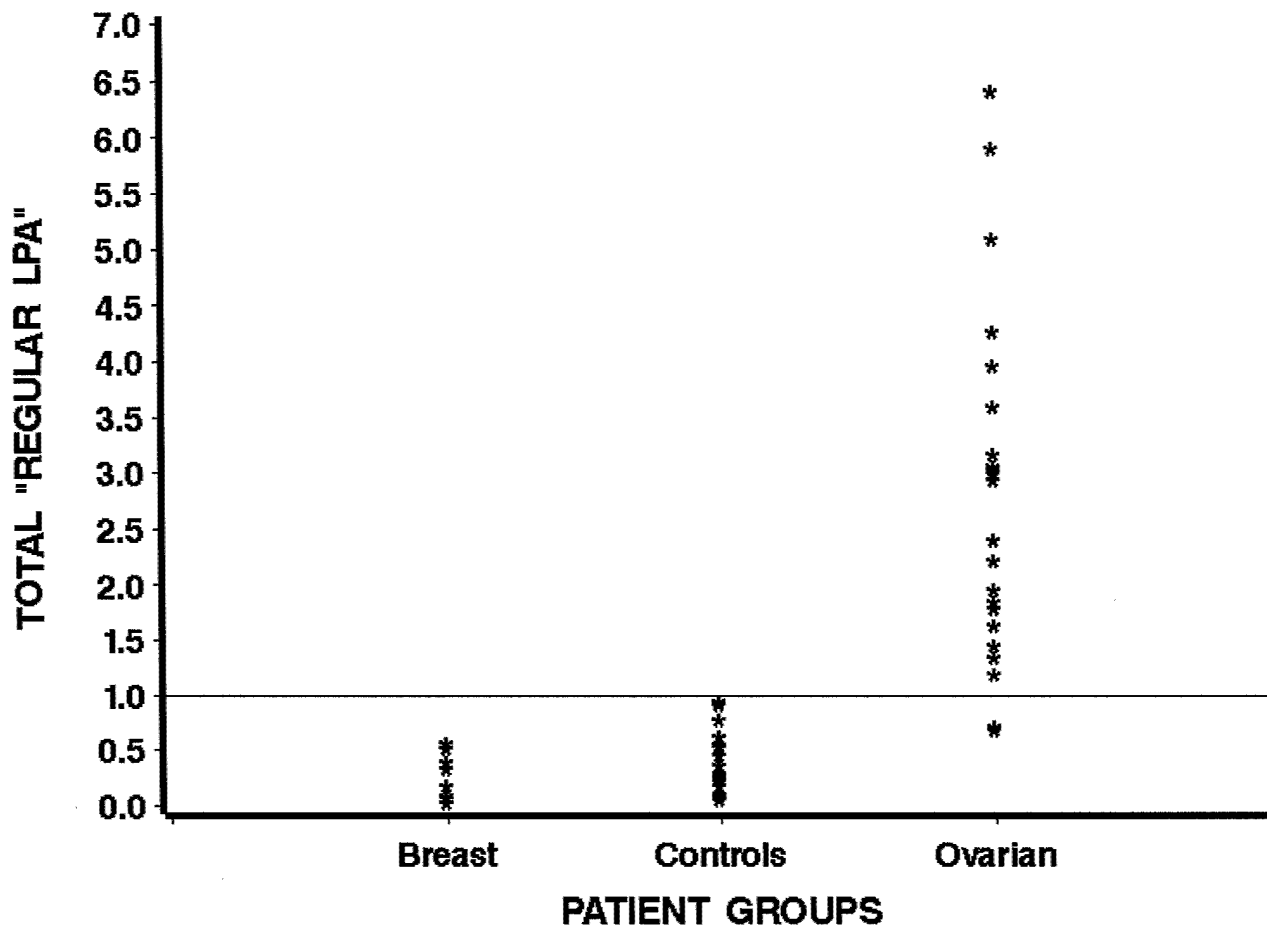

Work accomplished as proposed in Task 2 in the last year

1. The first mammalian lysophospholipase D (lyso-PLD) has been identified recently by two Japanese groups (5,6). We have found that a lysoPLD-like activity is present in ascites from patients with ovarian cancer (Ref 4; appendices).

2. We have found that when HEY cells were incubated in 6-well plates coated with BSA (as a control) or different extracellular matrix (ECM)s, laminin, *but not any other ECMs*, stimulated an approximately 4-fold increase of LPA (Fig. 7A). To study the mechanisms of LPA produced by laminin, we tested a number of phospholipase inhibitors: HELSS (a iPLA₂ specific inhibitor, AACOCF₃ (an iPLA₂ and cPLA₂ inhibitor), 1-butanol (a PLD inhibitor), and GF 109203X (GFX; a PKC inhibitor). Both HELSS and AACOCF₃ but not 1-butanol and GFX, significantly inhibited the LPA production (Fig. 7B). These results suggest that an iPLA₂, but not PLD, or a GFX-sensitive PKC, is involved in the laminin-induced LPA production. Importantly, we found that the β₁ neutralizing antibody completely blocked the production of LPA (Fig. 7B), indicating that laminin-induced LPA production via activating a β₁ integrin(s).

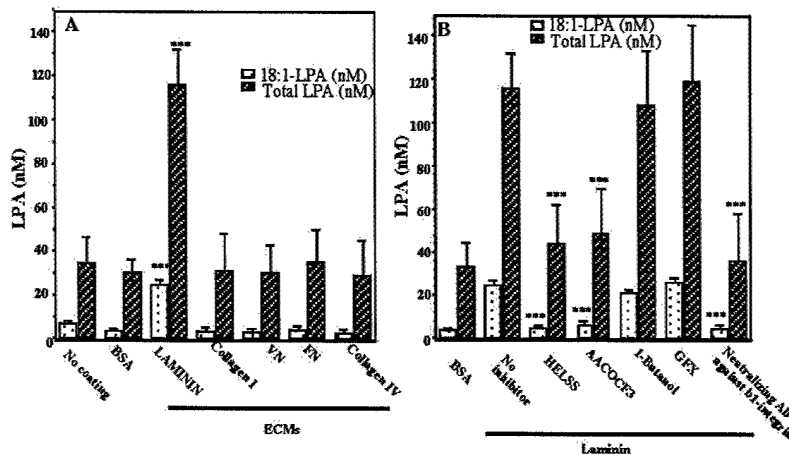

Fig. 7 Laminin-induced LPA production in HL₁ cells. A. 6-well plates were coated with different ECMs (10 μ g/mL) and blocked with BSA (0.1%). Starved HEY cells (5×10^5 - 10^6 /well) were incubated in these wells for 4 hr. Cell supernatant was collected. LPA extraction and analyses were performed as described previously⁶ (appendix 1). B. 6-well plates were coated with laminin and blocked with BSA. Starved HEY cells were treated with or without inhibitors or the neutralizing antibody against β_1 integrin prior to incubation in the coated wells. LPA production (18:1-LPA and total LPA) was presented as the mean \pm S.D. of three independent experiments. *** = $p < 0.001$ when compared with controls.

KEY RESEARCH ACCOMPLISHMENTS

- We demonstrated that early stage ovarian cancers, including microscopic diseases, have allelic losses at multiple chromosomal sites.
- We identified osteopontin as a potential serum biomarker for ovarian cancer.
- Gene expression analysis of the tumor samples has demonstrated that protease M is highly expressed in ovarian tumors of various stages and subtypes but not in the normal ovarian epithelial cells.
- Protease M recombinant protein has been made and preliminary studies have shown that it exhibits protease activity. The activity to peptide library will be determined.
- Monoclonal antibodies specific to protease M have been established. These will be characterized for immunohistochemistry and serum screening purposes.
- We showed that a significant concentration dependent increase was seen in cell proliferation when estrone (E1) or estradiol is added to primary or immortalized normal HOSE cells.
- We demonstrated that primary HOSE cells were more responsive to estrogens compared to immortalized normal HOSE cells. When they are grown in the presence of estradiol and FSH, they showed marked increase in cell proliferation. However, no additive effect of FSH was seen in any cell line tested.
- Addition of ICI to cell cultures attenuates estradiol induced cell proliferation.
- We showed that HOSE cells exposed to low concentrations (10^{-9} - 10^{-8} M) of DES for 14 days acquired ability to grow on soft agar, and HOSE cells exposed to DES and FSH form higher number of colonies on soft agar compared to FSH or DES alone.
- We have confirmed that LPA is a highly sensitive marker for detection of ovarian cancer.
- In addition, we have found that alkenyl-, acyl-LPAs, and lysophosphatidylinositol (LPI), may further increase the specificity and sensitivity of the LPA test. A US patent (#6,451,609) covering these findings has been issued.
- We have identified that iPLA₂ and lysoPLD may be important for LPA production from ovarian cancer cells. Further studies will reveal whether they are important target for the early prevention or the treatment of ovarian cancer.
- We have shown here for the first time that an ECM molecule is able to stimulate LPA production. This is also the first work to show that HEY ovarian cancer cells are able to produce LPA when stimulated by a physiological stimulus. This LPA production is potentially related to tumor cell metastasis. We believe that these findings are highly novel and significant to ovarian cancer.

REPORTABLE OUTCOMES

Project 1: Early genetic changes in human epithelial ovarian tumors

Manuscript:

1. Kim HK, Skates SJ, Uede T, Wong KK, Schorge JO, Feltmate CM, Berkowitz RS, Cramer DW, Mok SC. Osteopontin as a potential diagnostic biomarker for ovarian cancer. *JAMA* 2002, 287:1671-1679.
2. Wong KK, Cheng RS, Berkowitz RS, Mok SC. Gene expression analysis of ovarian cancer cells by cDNA microarray. In *Microarray and Cancer Research*. Ed. J.A. Warrington, C.R. Todd, and D. Wong. Eaton Publishing, Westboro, MA

Funding applied for based on the work supported by this award:

"Genetic alterations in early stage epithelial ovarian tumors " (4/1/03 -3/30/07)

Principal Investigator: Samuel C. Mok

Agent : NIH

Type: R33

To identify genetic changes in epithelial ovarian cancers.

Project 2: A Potential Serum Marker for Ovarian Cancer

In preparation

Project 3: Hormones as etiological factors of ovarian carcinogenesis

Manuscript:

1. Syed V, Lau KM, Mok SC, Ho SM. Profiling follicle stimulating hormone induced gene expression in normal and malignant human ovarian surface epithelial cells (submitted).

Abstract:

1. Syed V, Lau KM, Ho SM. Follicle stimulating hormone associated gene expression profiling in normal and malignant human ovarian surface epithelial cells. *Endocrinology Meeting*, June 2002, San Francisco, USA

Project 4: Development of a highly sensitive and specific method for the early detection and a strategy for the early intervention of ovarian cancer

Peer-reviewed publications

1. Baudhuin LM, Kristina KL, Lu, J, and Xu Y. Activation induced by LPA and S1P requires both MEK and p38 MAP kinase and is cell-line specific. *Mol Pharmacol* 62, 660-671, 2002.
2. Lu J, Xiao Y, Baudhuin LM, Hong G, and Xu, Y. Role and Signaling Pathways of Ether-linked Lysophosphatidic Acids in Ovarian Cancer Cells. *J. Lipid Res.* 43, 463-476, 2002.
3. Zhu, K., Baudhuin, L., Hong, G. Williams, F.S., Cristina, K.L., Kabarowski, J.H.S., Witte, O.N. and Xu, Y Sphingosylphosphorylcholine and lysophosphatidylcholine are ligands for the G protein coupled receptor, GRP4. *J Biol Chem.* 276(44):41325-41335, 2001.

Review papers

1. **Xu Y.** Sphingosylphosphorylcholine and lysophosphatidylcholine: G protein coupled receptors and receptor-mediated signal transduction. *Biochem Biophys Acta*, 1582, 81-88, 2002.
2. **Xu Y, Xiao Y, Zhu K, Baudhuin LM, Lu J, Hong G, Kim K-s, Cristina KL, Song L, Williams FS, Elson P, and Belinson J.** Unfolding the pathophysiological role of bioactive lysophospholipids. Current drug targets-immune, endocrine & metabolic disorders. In press
3. **Baudhuin L, Xiao Y, and Xu Y.** SPC/LPC receptors Handbook of Cellular Signaling. In press.

Abstracts:

1. Saubhik Sengupta, Yi-Jin Xiao, and Yan Xu Production of Lysophosphatidic Acid (LPA) by Laminin – Integrin Interaction is the key for Laminin induced Ovarian Cancer cell Migration. 22nd Annual Research Day at the Cleveland Clinic Foundation. Oct. 17, 2002.
2. Guiying Hong and Yan Xu OGR1 overexpression modulates cell-cell and cell-matrix interactions and induce cell apoptosis. 22nd Annual Research Day at the Cleveland Clinic Foundation. Oct. 17, 2002
3. Yi-jin Xiao, Benjamin Schwartz, Donna Fife, April While, Alexander Kennedy, Jerome Belinson, and Yan Xu. Analyses of LPA in peritoneal washings enhances of the sensitivity and specificity of ovarian cancer early detection. 22nd Annual Research Day at the Cleveland Clinic Foundation. Oct. 17, 2002
4. Baudhuin LM and Xu Y. Activation of Akt by LPA and SIP is Dependent on the Activaties of both ERK and p38 MAP kinases in HEY Ovarian Cancer Cells. 18th UICC International Cancer Congress (6/30-7/7/02 Oslo, Norway). Int. J. Cancer Supplemnt 13, P 806, 2002
5. **Xu Y** and Baudhuin LM. Sphingosine-1-phosphate-mediated activation of Akt through Edg-3, but not Edg-1, requires the activation of platelet-derived growth factor receptor. AACR 93rd Annual meeting, p1011 (April 6-10, 2002, San Francisco, CA)
6. **Xu Y, Lu J, Xiao Y, Baudhuin LM, and Hong G.** Role and Signaling Pathways of Ether-linked Lysophosphatidic Acids in Ovarian Cancer Cells. AACR 93rd Annual meeting, p255 (April 6-10, 2002, San Francisco, CA)

Presentations:

1. "Role and signaling pathways of lysophospholipids in cancer" (an invited talk at Mayo Clinic) (9/24/02)
2. "Biomarker detection in breast cancer" Breast cancer conference, The Taussig Cancer Center, 9/19/02.
3. "Bioactive lysophospholipids, their receptors, and cancers" The Netherlands Cancer Institute, Amsterdam, Netherlands, (7/8/02).
4. "Receptors for SPC and LPC" (an invited talk at the Annual Meeting GERLI 2000) (4/18/01) Nantes, France.
5. "Role of signaling pathways of lysophospholipids in cancer" (an invited talk in the Department of Pathology, Case Western Research University) (4/29/02).
6. "Role of signaling pathways of lysophospholipids in cancer" (ICOS LLC; Alameda, CA; 2/25/02).
7. "Role of signaling pathways of lysophospholipids in cancer" (Department of Pharmacology, Case Western Reserve University; 2/21/02).
8. "The potential pathological roles of LPA in ovarian cancer" (an invited talk at the 74th Annual Meeting of the Japanese Biochemical Society; 10/27/01).

9. "G protein coupled receptors for LPC and SPC" (a talk at the CCF Retreat; Maumee Bay, OH; 9/11/01).
10. "G protein coupled receptors for LPC and SPC" (Beijing University, Beijing, P.R. China; 9/25/01).
11. "Role of signaling pathways of lysophospholipids in cancer" (Institute of Animal, The Chinese Academy of Science; Beijing, P.R.China; 9/28/01).
12. "Role of signaling pathways of lysophospholipids in cancer" (Beijing Normal University, P.R.China; 10/5/01).

Patent

Xu Y, Xiao Y US patent 6,451,609 9/17/2002; Method of Detecting Gynecological Carcinomas

Degree obtained that is supported in part by this award

Dr. Linnea Baudhuin has obtained her Ph.D. in May 2002

Funding applied for based on the work supported by this award:

"Novel lipid signaling pathways in ovarian cancer cells"

Principal Investigator: Yan Xu

Agent: To be submitted as a revision to NIH by 11/01/02

Type: RO1

Understand the signaling mechanisms of lipid molecules in ovarian cancer cells and identify novel targets to be used as potential therapeutics for the treatment of cancer.

CONCLUSIONS

Project 1: Early genetic changes in human epithelial ovarian tumors

We showed that high frequencies of LOH can be identified in multiple chromosomal arms in early stage ovarian cancer. Whether different subtypes of ovarian cancers have different allelic loss patterns is under investigation. We also demonstrated that osteopontin in a candidate biomarker for ovarian cancer, which may have clinical usefulness.

Project 2: A Potential Serum Marker for Ovarian Cancer

Analysis of the tumor samples has demonstrated that protease M is highly expressed in ovarian tumors of various stages and subtypes but not in the normal ovarian epithelial cells. This is important for the development of screening tools for early detection of ovarian cancer. Characterization of protease M recombinant protein suggested that it exhibits protease activity. Generation of monoclonal antibodies to protease M will enhance the process of immunodetection of the proteins in archived materials and patient serum.

Project 3: Hormones as etiological factors of ovarian carcinogenesis

All the cell lines responded equally well to E2 and E1 except HOSE 12-12 cell line, where E1 was more effective than E2 in inducing cell proliferation. Furthermore, No synergism was observed when cultures were challenged simultaneously with FSH and E2. Furthermore, treatment of HOSE cells with FSH and estrogens enhance their colony formation potential on soft agar.

Project 4: Development of a highly sensitive and specific method for the early detection and a strategy for the early intervention of ovarian cancer

We have made important accomplishment in developing a method of detecting and a strategy for the early intervention of ovarian cancer. The newly developed ESI-MS-based on method is highly sensitive, reproducible and quantitative. We confirmed that LPA levels are elevated in plasma from patients with ovarian cancer using the MS-based method. Data analyses are in progress to determine the specificity of the test. More clinical samples will be collected in the third year of the grant to further assess the sensitivity and specificity of the test.

Using the MS method, we have found that a number of other lysophospholipids, including alkyl-LPA, alkenyl-LPA, LPI, SPC and LPC are also elevated in ascites from patients with ovarian cancer, compared with ascites from patients with non-malignant diseases (3). The diagnostic, prognostic, and clinic management significance of these lipids is under investigation.

Importantly, we have recently identified the first receptors for SPC and LPC (4-7). These discoveries provide an intriguing opportunity and a novel approach to study the roles of SPC and LPC in ovarian cancer. In addition, we have found lysophospholipase D (Lyso-PLD) activity in ovarian cancer ascites. To target these receptors and lyso-PLD as an early intervention strategy is under investigation.

REFERENCES

1. **Xu Y**, Shen Z, Wiper DW, Wu M, Morton RE, Elson P, Kennedy AW, Belinson, J, Markman M, Casey G. Lysophosphatidic acid as a potential biomarker for ovarian and other gynecologic cancers. *JAMA* 280, 719-723, 1998.
2. **Xu Y**, Xiao, Y, Baudhuin LM, Schwartz BM. The role and clinical applications of bioactive lysolipids in ovarian cancer. *J. Soc. Gyn. Invest* 8,1-13, 2001.
3. **Xu Y**, Xiao Y, Zhu K, Baudhuin LM, Lu J, Hong G, Kim K-s, Cristina KL, Song L, Williams FS, Elson P, and Belinson J. Unfolding the pathophysiological role of bioactive lysophospholipids. Current drug targets-immune, endocrine & metabolic disorders. In press
4. Bauhuin L, Xiao Y, and **Xu Y**. SPC/LPC receptors Handbook of Cellular Signaling. In press.
5. Umezū-Goto, M. et al. Autotaxin has lysophospholipase D activity leading to tumor cell growth and motility by lysophosphatidic acid production. *J Cell Biol* 158, 227-33. (2002).
6. Tokumura, A. et al. Identification of human plasma lysophospholipase D, a lysophosphatidic acid-producing enzyme, as autotaxin, a multifunctional phosphodiesterase. *J Biol Chem* 9, 9 (2002).

APPENDICES

Journal articles:

1. Kim HK, Skates SJ, Uede T, Wong KK, Schorge JO, Feltmate CM, Berkowitz RS, Cramer DW, **Mok SC**. Osteopontin as a potential diagnostic biomarker for ovarian cancer. *JAMA*, 287, 1671-1679, 2002.
2. Wong KK, Cheng RS, Berkowitz RS, **Mok SC**. Gene expression analysis of ovarian cancer cells by cDNA microarray. In *Microarray and Cancer Research*. Ed. J.A. Warrington, C.R. Todd, and D. Wong. Eaton Publishing, Westboro, MA

3. Baudhuin LM, Kristina KL, Lu, J, and **Xu Y**. Activation induced by LPA and S1P requires both MEK and p38 MAP kinase and is cell-line specific. *Mol Pharmacol* 62, 660-671, 2002.
4. Lu J, Xiao Y, Baudhuin LM, Hong G, and **Xu, Y**. Role and Signaling Pathways of Ether-linked Lysophosphatidic Acids in Ovarian Cancer Cells. *J. Lipid Res.* 43, 463-476, 2002.
5. Zhu, K., Baudhuin, L., Hong, G. Williams, F.S., Cristina, K.L., Kabarowski, J.H.S., Witte, O.N. and **Xu, Y** Sphingosylphosphorylcholine and lysophosphatidylcholine are ligands for the G protein coupled receptor, GRP4. *J Biol Chem.* 276(44):41325-41335, 2001.
6. **Xu Y**. Sphingosylphosphorylcholine and lysophosphatidylcholine: G protein coupled receptors and receptor-mediated signal transduction. *Biochem Biophys Acta*, 1582, 81-88, 2002.

Papers in print

1. **Xu Y**, Xiao Y, Zhu K, Baudhuin LM, Lu J, Hong G, Kim K-s, Cristina KL, Song L, Williams FS, Elson P, and Belinson J. Unfolding the pathophysiological role of bioactive lysophospholipids. Current drug targets-immune, endocrine & metabolic disorders. In press
2. Bauhuin L, Xiao Y, and **Xu Y**. SPC/LPC receptors Handbook of Cellular Signaling. In press.

Abstracts:

1. Saubhik Sengupta, Yi-Jin Xiao, and Yan Xu Production of Lysophosphatidic Acid (LPA) by Laminin – Integrin Interaction is the key for Laminin induced Ovarian Cancer cell Migration. 22nd Annual Research Day at the Cleveland Clinic Foundation. Oct. 17, 2002.
2. Guiying Hong and Yan Xu OGR1 overexpression modulates cell-cell and cell-matrix interactions and induce cell apoptosis. 22nd Annual Research Day at the Cleveland Clinic Foundation. Oct. 17, 2002.
3. Yi-jin Xiao, Benjamin Schwartz, Donna Fife, April While, Alexander Kennedy, Jerome Belinson, and Yan Xu. Analyses of LPA in peritoneal washings enhances of the sensitivity and specificity of ovarian cancer early detection. 22nd Annual Research Day at the Cleveland Clinic Foundation. Oct. 17, 2002.
4. Baudhuin LM and Xu Y. Activation of Akt by LPA and S1P is Dependent on the Activaties of both ERK and p38 MAP kinases in HEY Ovarian Cancer Cells. 18th UICC International Cancer Congress (6/30-7/7/02 Oslo, Norway). *Int. J. Cancer Supplemnt* 13, P 806, 2002
5. **Xu Y** and Baudhuin LM. Sphingosine-1-phosphate-mediated activation of Akt through Edg-3, but not Edg-1, requires the activation of platelet-derived growth factor receptor. AACR 93rd Annual meeting, p1011 (April 6-10, 2002, San Francisco, CA).
6. **Xu Y**, Lu J, Xiao Y, Baudhuin LM, and Hong G. Role and Signaling Pathways of Ether-linked Lysophosphatidic Acids in Ovarian Cancer Cells. AACR 93rd Annual meeting, p255 (April 6-10, 2002, San Francisco, CA)

Patent

Xu Y, Xiao Y US patent 6,451,609 9/17/2002; Method of Detecting Gynecological Carcinomas

A curriculum vitae

Gene Expression Analysis of Ovarian Cancer Cells by cDNA Microarrays

Kwong-Kwok Wong¹, Rita S. Cheng¹, Ross S. Berkowitz²,
and Samuel C. Mok²

¹Texas Children's Cancer Center, Baylor College of Medicine, Houston, TX
and ²Brigham and Women's Hospital, Harvard Medical School, Boston,
MA, USA

INTRODUCTION

Ovarian cancer (OVCA) ranks closely behind pancreatic cancer as the fifth leading cause of death from cancer in US women and is the most lethal of the gynecologic cancers (1). Most cases are detected at late stages and are rarely curable. A majority of women with OVCA are diagnosed when they have distant disease, and their survival is around 28% at 5 years (22). On the other hand, 5 years survival for localized disease is about 95% (depending on tumor grade), but only a minority of women are detected at this stage. This dismal prognosis has stimulated research on methods for early detection with the hope of improved survival, but such work has failed thus far to yield a satisfactory screening procedure.

Currently, clinical management of epithelial OVCA relies in part on the stage and phenotype or histopathology of the ovarian tumors and usually begins with surgical cytoreduction followed by consolidative chemotherapy. Good responses to this general approach have not been completely achieved. Most tumors will either recur after definitive treatment or be chemoresistant from the outset. This is partly due to our lack of understanding of the pathogenesis of OVCA.

It is believed that the vast majority of OVCA are carcinomas of the surface epithelial type. Based on the current knowledge on gene expression of a few differentially expressed genes and the loss of heterozygosity (LOH) in ovarian tumors with different histopathology, a working hypothesis for the pathogenetic pathways in ovarian carcinogenesis is proposed (Figure 1). However, there are still many unknown pathways connecting all these ovarian tumors with different histopathology. Because the biological behavior of the tumor cells may be a manifestation of genes expressed by these cells, gene expression analysis by cDNA microarray is a powerful tool to identify numerous differentially expressed genes. Further analysis of a large set of differentially expressed genes will contribute to our understanding of the pathogenetic pathways in ovarian carcinogenesis.

cDNA MICROARRAY ANALYSIS

Choice of Samples and the Identification of Differentially Expressed Genes

Microarray technology has evolved as a major discovery tool to identify relevant biomarkers for various types of cancers (26,33,35,38) and has been applied for the molecular classification of tumors (8). The simultaneous comparison of the expression of thousands of genes in two different samples by microarray allows the identification of a large number of potential candidate genes for subsequent analysis and applications (24). However, one of the important factors for the successful discovery of relevant biomarkers relies on the choice of relevant samples for comparison. Since most OVCA are derived from the ovarian surface epithelial cells, the use of surface epithelial cells will be most appropriate for the comparison with cancer cells.

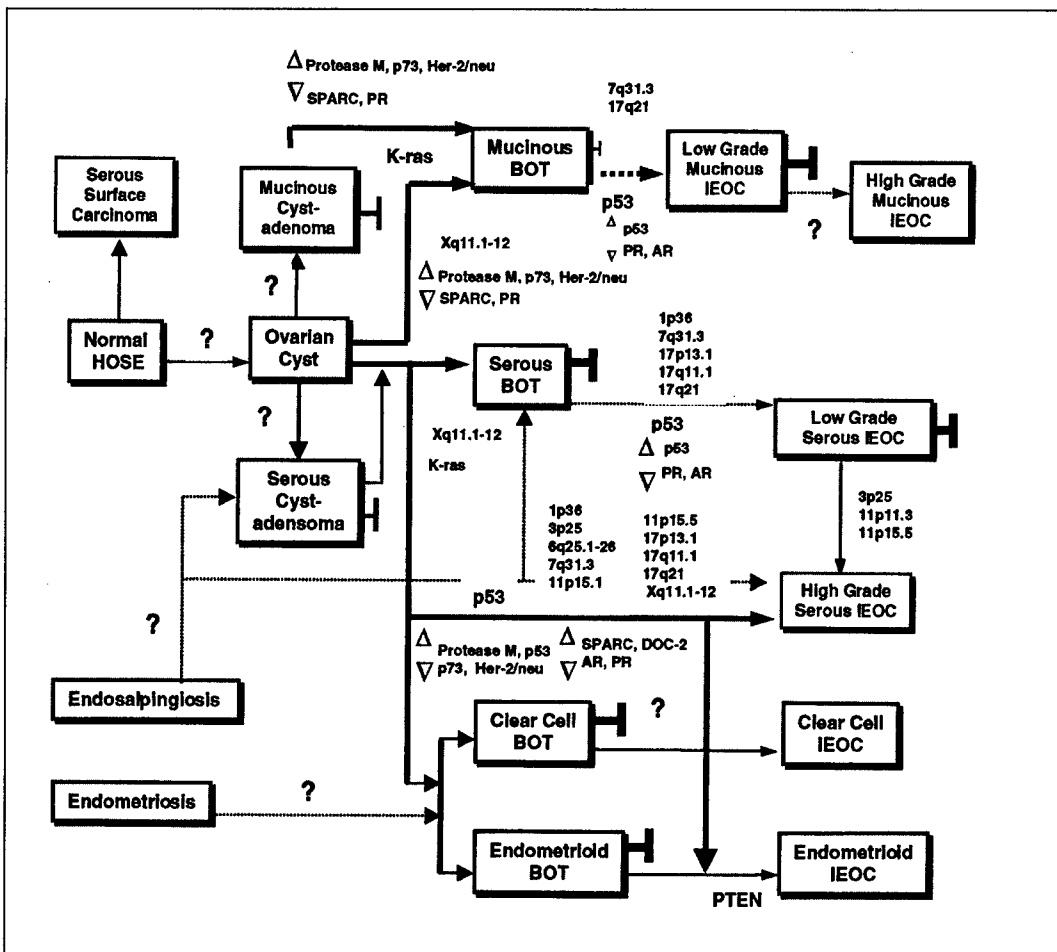

Figure 1. Working hypothesis for pathogenetic pathways in ovarian carcinogenesis. Gene mutational analyses include p53, PTEN, and K-ras. Loci on chromosome 1, 3, 6, 7, 11, 17, and X that demonstrated LOH are shown in italic. Overexpressed and down-regulated genes are indicated by ▲ and ▼, respectively. HOSE, human ovarian surface epithelium; BOT, borderline ovarian tumor; and IEOC, invasive epithelial ovarian carcinoma.

In our study, we compared the expression of 2400 genes between primary human ovarian surface epithelial (HOSE) cells and OVCA cells using the MICROMAX™ cDNA microarray system (NEN Life Science Products, Boston, MA, USA). Three primary HOSE cells from different individuals were pooled together as a normal sample. The use of pooled normal samples has two advantages: (i) fluctuations in gene expression among normal HOSE cells due to the individual difference in age or physiological states may be minimized; and (ii) sufficient amount of RNA for direct labeling can be obtained from the precious primary cell cultures. Similarly, three different cancer cell lines were pooled together as an OVCA sample for the analysis. The use of cancer cell lines has the advantage of being homogeneous. On the other hand, tumor tissue may be problematic because it is usually quite heterogeneous.

We have identified 47 genes overexpressed (Table 1 and Table 2) and 58 genes down-regulated in OVCA cells (Table 3) from a single microarray experiment. However, the list of genes described here is different from two similar studies reported previously (25,34). Only a few differentially expressed genes were shared by these studies. The differences in the list of differentially expressed genes may be due to the use of different samples in the analysis. We compared the gene expression of primary normal ovarian surface epithelial cells and OVCA cell lines. In one of the previous studies, gene expression of normal ovary was compared with tumor tissues (34), while gene expression of low passage ovarian surface epithelial cells were compared with tumor tissues in another study (25). Apparently, the choice of samples for analysis would account for the different set of genes identified. However, further analysis is needed to evaluate the clinical and biological significance of these differentially expressed genes. Ideally, laser captured microdissection of primary tumor tissue for comparison with microdissected ovarian surface epithelial cells should be used. Unfortunately, the insufficient amount of RNA that can be obtained from microdissected material poses a challenge for microarray analysis. We hope a more sensitive and reliable method that only requires a few nanograms of total RNA for microarray analysis will be developed soon.

Background Hybridization Signal and the Identification of Weakly Expressed Genes

We used the MICROMAX cDNA microarray system for our study because a much smaller amount of total RNA is needed. TSA™ signal amplification (NEN Life Science Products) in the MICROMAX cDNA microarray system reduces the amount of total RNA needed to a few micrograms, which is about 20 to 100 times less than the currently used method (24). The detail of MICROMAX cDNA microarray system has been previously described (2,37). Gene expression from OVCA sample was detected as Cy3™ signal (Amersham Pharmacia Biotech, Piscataway, NJ, USA), while gene expression from HOSE sample was detected as Cy5™ signal (Amersham Pharmacia Biotech) (Figure 2). After completion of the recommended procedures, significant background signal was still observed in the Cy3 signal that was derived from OVCA sample. A series of additional stringent posthybridization washes were able to reduce the background signal (Figure 2). The Cy3 to Cy5 ratios for each of the 2400 genes before and after the stringent posthybridization washes were plotted as two curves for comparison (Figure 3). The result indicated that while the Cy3 to Cy5 ratios for most of the genes increased slightly after stringent posthybridization washes, the ratios for some genes increased significantly. The number of genes with signal to background ratios more than 3-fold has increased from 740 to 791. More importantly, after the strin-

Table 1. Genes Overexpressed in OVCA Cells More than 10-Fold

Accession No.	Description	(OVCA/ HOSE)	OVCA Signal Intensity
M33011	Carcinoma-associated antigen GA733-2	444	1249
J04765	Osteopontin	184	11 851
L41351	Prostasin	170	3172
L19783	GPI-H	88	916
U96759	Von Hippel-Lindau binding protein (VBP-1)	59	1377
M57730	B61	49	5514
L33930	CD24 signal transducer and 3' region	47	26 722
D55672	hnRNP D	44	950
U97188	Putative RNA binding protein KOC	38	3599
L19871	ATF3	37	3507
J04991	p18	34	9914
D00762	Proteasome subunit HC8	29	4703
U17989	Nuclear autoantigen GS2NA	28	721
U43148	Patched homolog (PTC)	28	4155
AF010312	Pig7 (PIG7)	23	17 379
M80244	E16	21	4180
X99802	ZYG homologue	21	2086
U05598	Dihydrodiol dehydrogenase	18	21 595
L47647	Creatine kinase B	18	787
M55284	Protein kinase C-L (PRKCL)	16	863
X15722	Glutathione reductase	14	794
S54005	Thymosin beta-10	13	1476
AB006965	Dnm1p/Vps1p-like protein	13	4183
M83653	Cytoplasmic phosphotyrosyl protein phosphatase	13	2156
X12597	High mobility group-1 protein (HMG-1)	12	2785
M18112	Poly(ADP-ribose) polymerase	12	9277
U56816	Kinase Myt1 (Myt1)	11	1773
X06233	Calcium-binding protein in macrophages (MRP-14)	11	3007
D85181	Fungal sterol-C5-desaturase homologue	11	3571
M31627	X box binding protein-1 (XBP-1)	10	12 151

Reproduced with permission from Reference 37.

Gene Expression Analysis of Ovarian Cancer Cells

Table 2. Weakly Expressed Genes, Overexpressed in OVCA Cells More than 10-Fold Identified After Stringent Washes

Accession No.	Description	(OVCA/ HOSE)	OVCA Signal Intensity
AF005654	Actin-binding double-zinc-finger protein (abLIM)	18770	751
L10844	Cellular growth-regulating protein	33	725
M88163	Global transcription activator homologous sequence	18	642
U02882	Rolipram-sensitive 3',5'-cyclic AMP phosphodiesterase	27	636
X12517	U1 small nuclear RNP-specific C protein	112	550
D29833	Salivary proline rich peptide P-B	10	492
AF020918	Glutathione transferase (GSTA4)	47	475
J05262	Farnesyl pyrophosphate synthetase	95	469
L08424	Achaete scute homologous protein (ASH1)	57	457
M84526	Adipsin/complement factor D	65	441
U35113	Metastasis-associated mta1	13	367
D28468	DNA-binding protein TAXREB302	268	357
AF012126	Zinc finger protein (ZNF198)	15	342
AB000714	RVP1	11	314
AF029750	Tapasin (NGS-17)	118	305
X60489	Elongation factor-1-beta	10	282
L36645	Receptor protein-tyrosine kinase (HEK8)	71	273

Genes were identified after stringent posthybridization wash.

gent posthybridization washes, we were able to detect the weakly expressed genes that are differentially overexpressed in OVCA cells (Table 2). Those genes correspond to the peaks in the curve of Figure 3.

Genes Overexpressed in Ovarian Cancer Cells

From the list of overexpressed genes, several putative mechanisms may be involved in the pathogenesis of OVCA: (i) inactivation of tumor suppressor; (ii) altered expression of transcription factors; (iii) overexpression of oncogenes; (iv) overexpression of glycosylphosphatidylinositol (GPI) anchor-associated proteins; and (v) altered cell cycle control. According to this list of genes, VBP1 interacts with the product of the von Hippel-Lindau

Table 3. Genes Down-Regulated in OVCA Cells More than 10-Fold

Accession No.	Description	(HOSE/ OVCA)	HOSE Signal
D45421	Phosphodiesterase I alpha	∞	667
M35410	Insulin-like growth factor binding protein 2 (IGFBP2)	∞	1517
X81334	Collagenase-3 protein	∞	5146
D13665	Osteoblast specific factor 2 (OSF-2p1)	∞	24 300
J03040	SPARC/osteonectin	∞	28 711
D86043	SHPS-1	681	9450
U89942	Lysyl oxidase-related protein (WS9-14)	454	25 055
M59807	NK4	118	22 438
Z74616	Prepro-alpha2(I) collagen	101	2281
Z74615	Prepro-alpha1(I) collagen	81	24 323
X06596	Complement component C1s	76	22 672
M95787	22 kDa smooth muscle protein (SM22)	71	31 581
X06256	Fibronectin receptor alpha subunit	66	27 901
M36981	Putative NDP-kinase (nm23-H2S)	60	15 411
AJ001838	Maleylacetoacetate isomerase	59	304
X56160	Tenascin	42	36 062
D21254	OB-cadherin-1	40	20 621
Y07921	Serine protease	37	2247
Y10032	Putative serine/threonine protein kinase	36	8510
X04526	Beta-subunit signal transducing proteins Gs/Gi (beta-G)	36	13 321
L31409	Creatine transporter	35	8677
X04701	Complement component C1r	33	10 299
X13839	Vascular smooth muscle alpha-actin	32	27 311
X84908	Phosphorylase-kinase, beta subunit	30	11 341
L14595	Alanine/serine/cysteine/threonine transporter (ASCT1)	27	2234
M97796	Helix-loop-helix protein (Id-2)	25	3187
X04741	Protein gene product (PGP) 9.5	25	13 138
Y10055	Phosphoinositide 3-kinase	23	614
X83535	Membrane-type matrix metalloproteinase	20	6464
U69546	RNA binding protein Etr-3	18	2714
U16268	AMP deaminase isoform L, alternatively spliced (AMPD2) mRNA, exons 1B, 2, and 3	18	3512
S59749	5E10 antigen	18	1249
U03057	Actin bundling protein (HSN)	17	9285
J02854	20 kDa myosin light chain (MLC-2)	16	8323
X16940	Enteric smooth muscle gamma-actin	16	18 776

Gene Expression Analysis of Ovarian Cancer Cells

Table 3. (Continued)

Accession No.	Description	(HOSE/ OVCA)	HOSE Signal
X13223	N-acetylglucosamide-(beta 1-4)-galactosyltransferase	16	3357
M69181	Nonmuscle myosin heavy chain-B (MYH10)	16	11 126
X06990	ICAM-1	16	25 605
M13656	Plasma protease (C1) inhibitor	15	1091
X73608	Testican	15	2977
M96803	General beta-spectrin (SPTBN1)	15	13 359
D00632	Glutathione peroxidase	15	4951
X03445	Nuclear envelope protein lamin C precursor	13	17 451
L06419	Lysyl hydroxylase (PLOD)	13	9288
M12125	Fibroblast muscle-type tropomyosin	12	34 379
S45630	Alpha B-crystallin, Rosenthal fiber component	12	1536
AB005298	BAI 2	11	3839
L77864	Stat-like protein (Fe65)	11	1914
AB007144	ZIP-kinase	11	4277
M16538	Signal-transducing guanine nucleotide-binding regulatory (G) protein beta subunit	11	2793
L35545	Endothelial cell protein C/APC receptor (EPCR)	11	1002
M75161	Granulin	11	13 289
X69910	p63	11	16 460
D12686	eIF-4 gamma	11	21 555
L07594	Transforming growth factor-beta type III receptor (TGF-beta)	11	672
M33294	Tumor necrosis factor receptor	10	6592
U18121	136 kDa double-stranded RNA binding protein p136 (K88dsRBP)	10	1619
M55618	Hexabrachion (HXB)	10	3866

∞, no detectable Cy3 signal from OVCA cells

gene and is expected to participate in pathways by inactivation of this tumor suppressor gene (4). RNA binding proteins, Koc and hnRNP D, may assume a role in the regulation of tumor cell proliferation by interfering with transcriptional and/or posttranscriptional processes of tumor suppressor genes. However, the precise role of these RNA binding proteins in human tumor cells is unknown and remains to be elucidated (19). ATF3 and XBP-1 are transcription factors that may play an important role in the regulation of gene expression by cAMP-dependent intracellular signaling pathways (6) and essential for hepatocyte growth, respectively (21). Also related to gene transcription, HMG-I protein has been im-

plicated as a potential marker for thyroid carcinoma (5). p18 and E16 are two oncogenes that have been found to be overexpressed in acute leukemia cells (16) and various human cancers (36), respectively. The GPI anchor, potentially capable of generating a number of second messengers, such as diacylglycerol, phosphatidic acid, and inositol phosphate glycan, has been postulated to be involved in signal transduction in various cell types, including T-cells (32). Genes encoding GPI-anchored proteins, GPI-H (10), B61 (27), and CD24 (23) were found to be overexpressed in OVCA cells (Table 1). Myt1 activity is temporally regulated during the cell cycle and is suggested to play a role in mitotic control (18). CD24, a GPI-anchored protein, is also involved in cell cycle control.

The differential expression of five interesting genes, GA733-2, osteopontin, *koc*, prostasin, and creatine kinase B, have previously been confirmed by real-time reverse transcription polymerase chain reaction (RT-PCR) (37). These five are either surface antigens or secreted proteins. Thus they may be potential serum markers. In fact, we have found that prostasin is significantly higher in the plasma from OVCA patient (data not shown). GA733-2 is known as epithelial cell surface antigen (EPG) or adenocarcinoma-associated antigen (KSA). These proteins may function as growth factor receptors (29). Osteopontin is an acidic phosphorylated glycoprotein of about 40 kDa which is abundant in the mineral

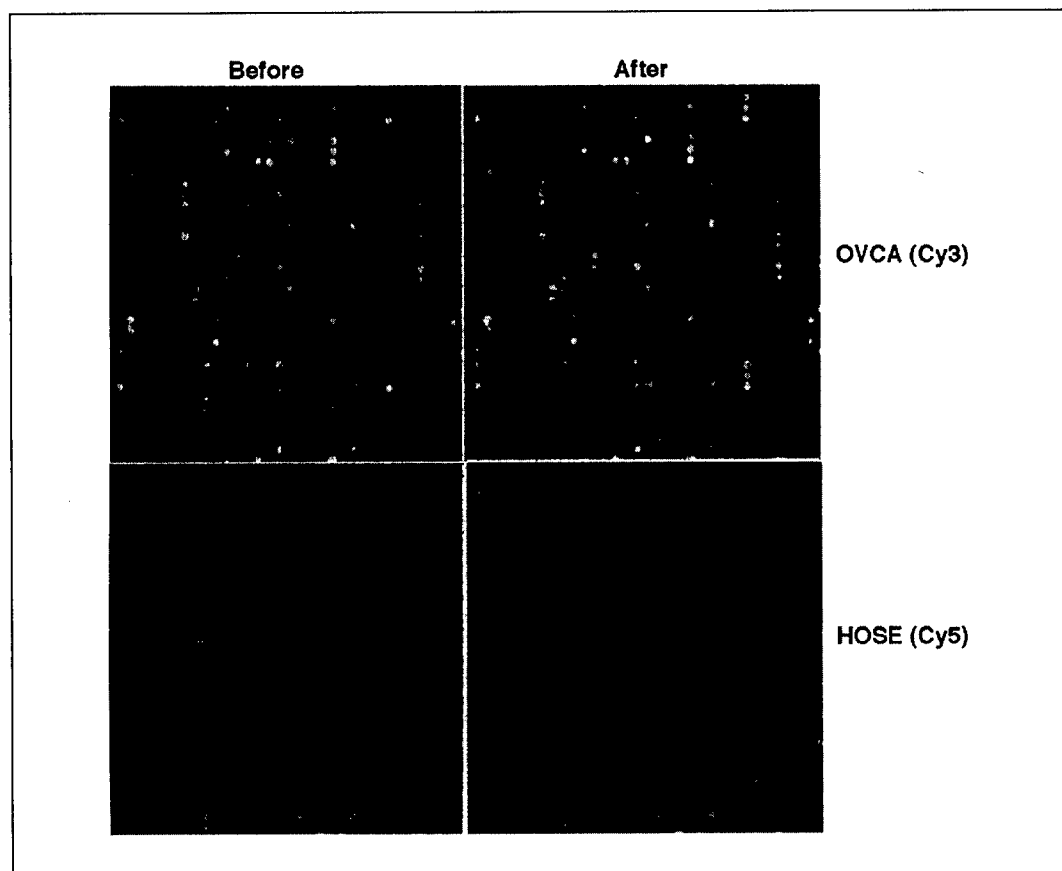

Figure 2. Hybridization signal before and after stringent posthybridization washes. Cy3 signal is derived from OVCA cells, and Cy5 signal is derived from normal ovarian surface epithelial cells. (See color plate A10.)

Gene Expression Analysis of Ovarian Cancer Cells

matrix of bones and possibly functions as a cell attachment factor involved in tumor invasion and metastasis (20). Prostatin is a serine proteinase expressed in prostate and prostate carcinoma (39). Creatine kinase has been shown to be at an elevated level in the blood of patients with renal cell carcinoma or small lung carcinoma (14,30). These overexpressed genes will be deserved of further analysis as potential use as diagnostic markers.

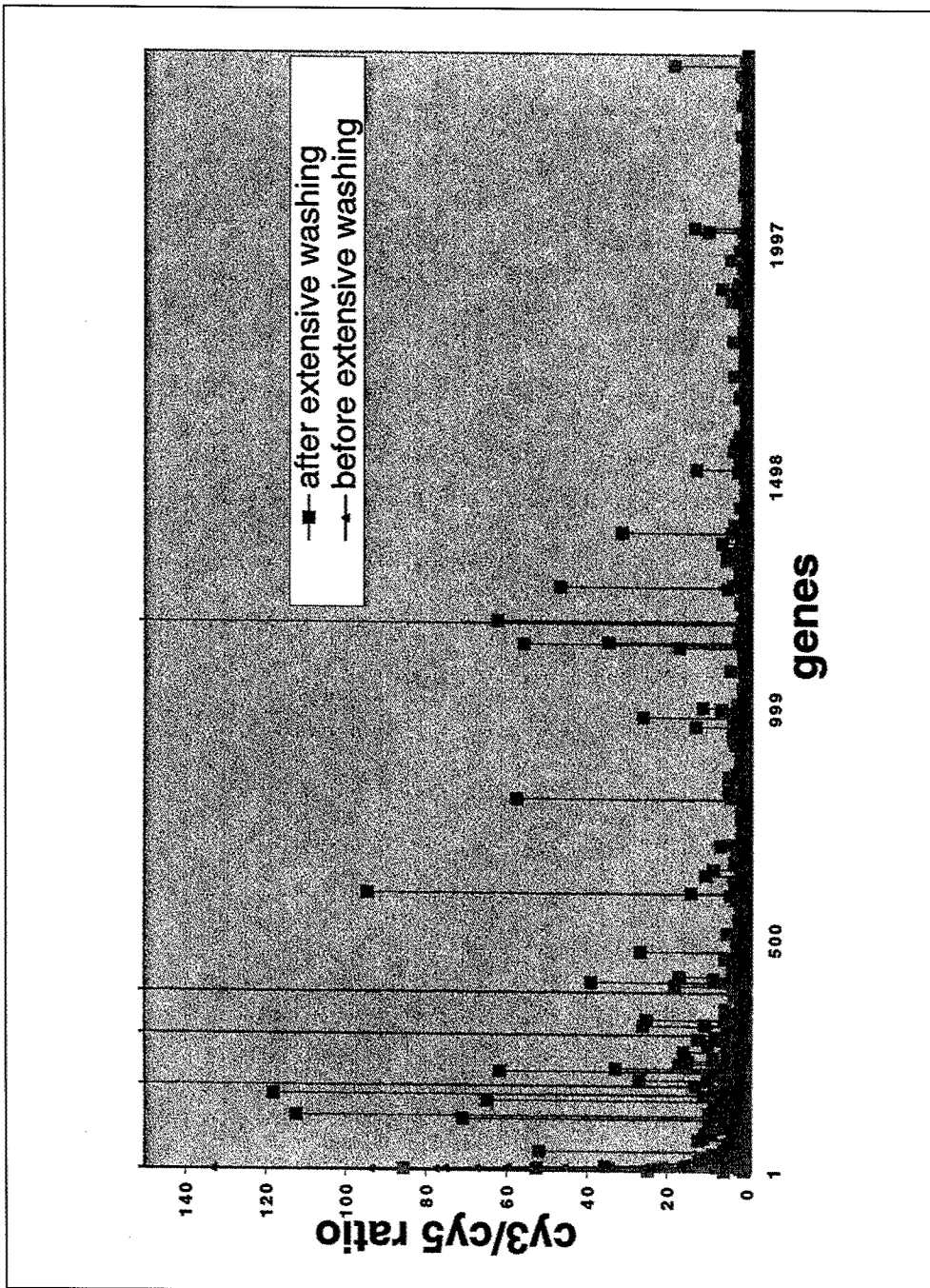

Figure 3. Cy3/Cy5 signal ratios for each of the 2400 genes before and after stringent posthybridization wash. Pink line represents ratio after stringent posthybridization wash, and blue line represents ratios before stringent posthybridization wash. (See color plate A11.)

Genes Down-Regulated in Ovarian Cancer Cells

More than 50 genes down-regulated in OVCA cells were identified in this study. In this list of genes (Table 3), SPARC/osteonectin has been previously identified by our laboratory as a down-regulated gene (17). SPARC is an extracellular matrix (ECM) protein with tumor-suppressing activity in human ovarian epithelial cells (17). Other ECM or ECM-related proteins such as fibronectin, tenascin, OB-cadherin-1, HXB, matrix metalloproteinase, and ICAM-1 were also found to be down-regulated. Tenascin has been suggested as a prognostic marker for colon cancer. Patients with more tenascin expression have better long-term survival than patients with no or weak expression (9). The disruption of the integrity of ECM may be essential to tumor progression of OVCA.

Several other genes involved in response to growth factors or mitogens were also down-regulated. These genes were Shps-1, phosphorylase-kinase, phosphoinositide 3-kinase, NDP-kinase, ZIP-kinase, signal transducing guanine nucleotide-binding regulatory protein, IGFBP2, TGF β , and TNF α receptor. SHPS-1, a novel glycoprotein, binds the Sh2 domain containing protein tyrosine phosphatase SHP-2 in response to mitogens and cell adhesion (7). Suppression of SHPS-1 expression by v-Src via the Ras-MAP kinase pathway has been shown to promote the oncogenic growth of cells (15). The NDP-kinase gene located on chromosome 17q has been proposed as a metastasis suppressor gene in a variety of tumor types (3). ZIP-kinase is a novel serine-threonine kinase and has been shown to mediate apoptosis through its catalytic activities (11). Previous study suggests that TGF β receptor complex and its downstream signaling intermediates constitute a tumor suppressor pathway (12). The stabilization of TNF α receptors on the surface of human colon carcinoma cells is necessary for TNF α -induced cell death (28). Besides these two major groups of genes, other genes encoding proteases and complement C1 components were also down-regulated. Some of these down-regulated genes, such as testican (13) and osteoblast specific factor 2 (31), have not yet been associated with carcinogenesis.

CONCLUSIONS

Using a commercial MICROMAX cDNA microarray, we were able to identify genes overexpressed or down-regulated in OVCA cells from a set of 2400 known human genes. Initial analysis of these differentially expressed genes has shed light on the possible mechanisms involved in the pathogenesis of OVCA. It is hoped that further analysis of these genes will contribute important information not only for a better understanding of the process of carcinogenesis, but also for assessing the biology and behavior of individual ovarian tumors, determining patient prognosis, and eventually influencing therapy. The use of microdissected primary tumor tissues for further confirmation of the differential expression will be needed in studies such as real-time RT-PCR analysis.

The availability of a commercial microarray that contains a large set of human genes and expressed sequence tags (ESTs) will further facilitate the identification of more new and novel biomarkers. Currently, the GeneChip™ U95 Set (Affymetrix, Santa Clara, CA, USA) represents more than 60 000 human genes and ESTs, while the cDNA microarray, GeneAlbum™ GEM™ 1-6 (IncyteGenomics, San Francisco, CA, USA) contains more than 52 000 different human genes today. These arrays are the two most complete *in vitro* resources available

Gene Expression Analysis of Ovarian Cancer Cells

for studying human gene expression. We expect that a large set of differentially expressed genes identified from microarray analysis can be further exploited for molecular classification of various ovarian tumor tissue samples, which will be a valuable tool to guide clinical management of the disease.

REFERENCES

1. American Cancer Society: *Cancer Facts & Figures*, 1999, American Cancer Society.
2. Adler K, Broadbent J, Garlick R, et al: MICROMAX™: a highly sensitive system for differential gene expression on microarrays. In Schena M, editor: *Microarray Biochip Technology*, Natick, 2000, Eaton Publishing, p 221.
3. Bodey B, Groger AM, Siegel SE, Kaiser HE: Nm23/nucleoside diphosphate (Ndp) kinase expression in human malignant melanomas—significance and implications in tumor biology. *Anticancer Res* 17:505, 1997.
4. Brinke A, Green PM, Giannelli F: Characterization of the gene (VBP1) and transcript for the von Hippel-Lindau binding protein and isolation of the highly conserved murine homologue. *Genomics* 45:105, 1997.
5. Chiappetta G, Tallini G, De Biasio MC, et al: Detection of high mobility group I HMGI(Y) protein in the diagnosis of thyroid tumors: HMGI(Y) expression represents a potential diagnostic indicator of carcinoma. *Cancer Res* 58:4193, 1998.
6. Chu HM, Tan Y, Kobierski LA, et al: Activating transcription factor-3 stimulates 3',5'-cyclic adenosine monophosphate-dependent gene expression. *Mol Endocrinol* 8:59, 1994.
7. Fujioka Y, Matozaki T, Noguchi T, et al: A novel membrane glycoprotein, Shps-1, that binds the Sh2-domain-containing protein tyrosine phosphatase Shp-2 in response to mitogens and cell adhesion. *Mol Cell Biol* 16:6887, 1996.
8. Golub TR, Slonim DK, Tamayo P, et al: Molecular classification of cancer: class discovery and class prediction by gene expression monitoring. *Science* 286:531, 1999.
9. Iskaros BE, Tanaka KE, Hu XP, et al: Morphologic pattern of tenascin as a diagnostic biomarker in colon cancer. *J Surg Oncol* 64:98, 1997.
10. Kamitani T, Chang HM, Rollins C, et al: Correction of the class H defect in glycosylphosphatidylinositol anchor biosynthesis in Ltk-cells by a human cDNA clone. *J Biol Chem* 268:20733, 1993.
11. Kawai T, Matsumoto M, Takeda K, Sanjo H, et al: ZIP kinase, a novel serine/threonine kinase which mediates apoptosis. *Mol Cell Biol* 18:1642, 1998.
12. Kim SJ, Im YH, Markowitz SD, Bang YJ: Molecular mechanisms of inactivation of TGF-beta receptors during carcinogenesis. *Cytokine Growth Factor Rev* 11:159, 2000.
13. Kohfeldt E, Maurer P, Vannahme C, Timpl R: Properties of the extracellular calcium binding module of the proteoglycan testican. *FEBS Lett* 414:557, 1997.
14. Kurtz KJ, Nielsen RD: Serum creatine kinase BB isoenzyme as a diagnostic aid in occult small cell lung cancer. *Cancer* 56:562, 1985.
15. Machida K, Matsuda S, Yamaki K, et al: v-Src suppresses SHPS-1 expression via the Ras-MAP kinase pathway to promote the oncogenic growth of cells. *Oncogene* 19:1710, 2000.
16. Melhem RE, Zhu XX, Hailat N, et al: Characterization of the gene for a proliferation-related phosphoprotein (oncoprotein 18) expressed in high amounts in acute leukemia. *J Biol Chem* 266:17747, 1991.
17. Mok SC, Chan WY, Wong KK, et al: SPARC, an extracellular matrix protein with tumor-suppressing activity in human ovarian epithelial cells. *Oncogene* 12:1895, 1996.
18. Mueller PR, Coleman TR, Kumagai A, Dunphy WG: Myt1: a membrane-associated inhibitory kinase that phosphorylates Cdc2 on both threonine-14 and tyrosine-15. *Science* 270:86, 1995.
19. Mueller-Pillasch F, Lacher U, Wallrapp C, et al: Cloning of a gene highly overexpressed in cancer coding for a novel KH-domain containing protein. *Oncogene* 14:2729, 1997.
20. Oates AJ, Barraclough R, Rudland PS: The role of osteopontin in tumorigenesis and metastasis. *Invasion Metastasis* 17:1, 1997.
21. Reimold A, Etkin MA, Clauss I, et al: An essential role in liver development for transcription factor XBP-1. *Genes Dev* 14:152, 2000.
22. Ries LAG, Kosary CL, Hankey BE, et al: *SEER Cancer Statistics Review 1973-1995*, Bethesda, 1998, National Cancer Institute.
23. Sammar M, Gulbins E, Hilbert K, et al: Mouse CD24 as a signaling molecule for integrin-mediated cell binding: functional and physical association with src-kinases. *Biochem Biophys Res Comm* 234:330, 1997.
24. Schena M, Shalon D, Davis RW, Brown PO: Quantitative monitoring of gene expression patterns with a complementary DNA microarray. *Science* 270:467, 1995.
25. Schummer M, Ng WV, Bumgarner RE, et al: Comparative hybridization of an array of 21,500 ovarian cDNAs for the discovery of genes overexpressed in ovarian carcinomas. *Gene* 238:375, 1999.
26. Sgroi DC, Teng S, Robinson G, et al: In vivo gene expression profile analysis of human breast cancer progression. *Cancer Res* 59:5656, 1999.

27. Shao H, Pandey A, O'Shea KS, et al: Characterization of B61, the ligand for the Eck receptor protein-tyrosine kinase. *J Biol Chem* 270:5636, 1995.
28. Smith MR, Kung H, Durum SK, et al: TIMP-3 induces cell death by stabilizing TNF-alpha receptors on the surface of human colon carcinoma cells. *Cytokine* 9:770, 1997.
29. Szala S, Froehlich M, Scollon M, et al: Molecular cloning of cDNA for the carcinoma-associated antigen GA733-2. *Proc Natl Acad Sci USA* 87:3542, 1990.
30. Takashi M, Zhu Y, Hasegawa S, Kato K: Serum creatine kinase B subunit in patients with renal cell carcinoma. *Urol Int* 48:144, 1992.
31. Takeshita S, Kikuno R, Tezuka K, Amann E: Osteoblast-specific factor 2: cloning of a putative bone adhesion protein with homology with the insect protein fasciclin I. *Biochem J* 294:271, 1993.
32. Thomas LJ, DeGasperi R, Sugiyama E, et al: Functional analysis of T-cell mutants defective in the biosynthesis of glycosylphosphatidylinositol anchor. Relative importance of glycosylphosphatidylinositol anchor versus N-linked glycosylation in T-cell activation. *J Biol Chem* 266:23175, 1991.
33. Villaret DB, Wang T, Dillon D, et al: Identification of genes overexpressed in head and neck squamous cell carcinoma using a combination of complementary DNA subtraction and microarray analysis. *Laryngoscope* 110:374, 2000.
34. Wang K, Gan L, Jeffery E, et al: Monitoring gene expression profile changes in ovarian carcinomas using cDNA microarray. *Gene* 229:101, 1999.
35. Wang T, Hopkins D, Schmidt C, et al: Identification of genes differentially over-expressed in lung squamous cell carcinoma using combination of cDNA subtraction and microarray analysis. *Oncogene* 19:1519, 2000.
36. Wolf DA, Wang S, Panzica MA, et al: Expression of a highly conserved oncofetal gene, TA1/E16, in human colon carcinoma and other primary cancers: homology to *Schistosoma mansoni* amino acid permease and *Caenorhabditis elegans* gene products. *Cancer Res* 56:5012, 1996.
37. Wong KK, Cheng RS, Mok SC: Identification of differentially expressed genes from ovarian cancer cells by MICRO-MAX™ cDNA microarray system. *BioTechniques* 30:670, 2001.
38. Xu J, Stolk JA, Zhang X, et al: Identification of differentially expressed genes in human prostate cancer using subtraction and microarray. *Cancer Res* 60:167, 2000.
39. Yu JX, Chao L, Chao J: Molecular cloning, tissue-specific expression, and cellular localization of human prostatic mRNA. *J Biol Chem* 270:13483, 1995.

Osteopontin as a Potential Diagnostic Biomarker for Ovarian Cancer

Jae-Hoon Kim, MD

Steven J. Skates, PhD

Toshimitsu Uede, MD

Kwong-kwok Wong, PhD

John O. Schorge, MD

Colleen M. Feltmate, MD

Ross S. Berkowitz, MD

Daniel W. Cramer, MD, ScD

Samuel C. Mok, PhD

OVARIAN CANCER RANKS AS the fifth leading cause of death from cancer and has the highest mortality rate among the gynecologic malignancies in the United States.¹ Every year approximately 25 000 ovarian cancer cases are newly diagnosed and approximately 15 000 deaths occur secondary to the malignancy.² This high case-fatality ratio reflects the fact that most ovarian cancer cases are detected at stage III or IV, at which the 5-year survival rate is below 30% compared with 95% with stage I.³ To improve survival, it would be desirable to develop tumor markers that could be used to detect the early stages of the disease.

The development of high-throughput complementary DNA (cDNA) microarray techniques offers great potential for identifying novel and specific biomarkers for the early detection of cancer.⁴⁻⁶ Using these techniques, potential serum markers for several cancers have been identified.⁶⁻⁹ In our study with the MICROMAX (PerkinElmer Life Sciences [previously NEN Life Sciences], Boston, Mass) cDNA microarray system using RNA isolated from several ovarian cancer cell

Context Development of new biomarkers for ovarian cancer is needed for early detection and disease monitoring. Analyses involving complementary DNA (cDNA) microarray data can be used to identify up-regulated genes in cancer cells, whose products may then be further validated as potential biomarkers.

Objective To describe validation studies of an up-regulated gene known as osteopontin, previously identified using a cDNA microarray system.

Design, Setting, and Participants Experimental and cross-sectional studies were conducted involving ovarian cancer and healthy human ovarian surface epithelial cell lines and cultures, archival paraffin-embedded ovarian tissue collected between June 1992 and June 2001, and fresh tissue and preoperative plasma from 144 patients evaluated for a pelvic mass between June 1992 and June 2001 in gynecologic oncology services at 2 US academic institutions. Plasma samples from 107 women selected from an epidemiologic study of ovarian cancer initiated between May 1992 and March 1997 were used as healthy controls.

Main Outcome Measures Relative messenger RNA expression in cancer cells and fresh ovarian tissue, measured by real-time polymerase chain reaction as 2^{-ΔΔCT} (a quantitative value representing the amount of osteopontin expression); osteopontin production, localized and scored in ovarian healthy and tumor tissue with immunohistochemical studies; and amount of osteopontin in patient vs control plasma, measured using an enzyme-linked immunoassay.

Results The geometric mean for 2^{-ΔΔCT} for osteopontin expression in 5 healthy ovarian epithelial cell cultures was 4.1 compared with 270.4 in 14 ovarian cancer cell lines ($P=.03$). The geometric mean 2^{-ΔΔCT} for osteopontin expression in tissue from 2 healthy ovarian epithelial samples was 9.0 compared with 164.0 in 27 microdissected ovarian tumor tissue samples ($P=.06$). Immunolocalization of osteopontin showed that tissue samples from 61 patients with invasive ovarian cancer and 29 patients with borderline ovarian tumors expressed higher levels of osteopontin than tissue samples from 6 patients with benign tumors and samples of healthy ovarian epithelium from 3 patients ($P=.03$). Osteopontin levels in plasma were significantly higher ($P<.001$) in 51 patients with epithelial ovarian cancer (486.5 ng/mL) compared with those of 107 healthy controls (147.1 ng/mL), 46 patients with benign ovarian disease (254.4 ng/mL), and 47 patients with other gynecologic cancers (260.9 ng/mL).

Conclusions Our findings provide evidence for an association between levels of a biomarker, osteopontin, and ovarian cancer and suggest that future research assessing its clinical usefulness would be worthwhile.

JAMA. 2002;287:1671-1679

www.jama.com

lines and healthy human ovarian surface epithelial (HOSE) cell cultures, we identified a spot with an ovarian cancer/HOSE ratio of 184 that corresponded to a protein called osteopontin.⁶ We present the experimental and clinical stud-

Author Affiliations and Financial Disclosures are listed at the end of this article.

Corresponding Author and Reprints: Samuel C. Mok, PhD, Laboratory of Gynecologic Oncology, Division of Gynecologic Oncology, Department of Obstetrics, Gynecology, and Reproductive Biology, Brigham and Women's Hospital, BLI-447, 221 Longwood Ave, Boston, MA 02115 (e-mail: scmok@rics.bwh.harvard.edu).

ies addressing the potential clinical usefulness of this marker.

METHODS

Cell Lines and Cultures

All ovarian cancer cell line material was obtained either by scraping the surfaces of healthy ovaries, recovery of material from ascites, or procurement of explanted tissue from solid tumors as described previously.¹⁰ Five healthy HOSE cell cultures used in this experiment were HOSE695, HOSE697, HOSE713, HOSE726, and HOSE730. Fourteen ovarian cancer cell lines were used: ALST, CAO3, DOV13, OVCA3, OVCA420, OVCA429, OVCA432, OVCA433, OVCA633, and SKOV3 originated from serous cystadenocarcinoma; RMUG-L and RMUG-S originated from mucinous cystadenocarcinoma; and RMG-1 and ES-2 originated from clear-cell carcinoma. All cell cultures and cell lines were established in the Laboratory of Gynecologic Oncology, Brigham and Women's Hospital, Boston, Mass, except OVCA3, SKOV3, RMUG-L, RMUG-S, RMG-1, and ES-2, which were purchased from the American Type Culture Collection (Rockville, Md) and the Japanese Collection of Research Bioresources (Tokyo, Japan), respectively.

Biosamples

All patient-derived specimens were collected and archived under protocols approved by the institutional review boards (IRBs) of the parent institutions. Paraffin blocks (n=99) of ovarian cancer and healthy tissue from the Brigham and Women's Hospital pathology department archives were collected between June 1992 and June 2001, representing a cross-section of histologic types and grades seen at the institution. The blocks were collected under a separate "discarded material" IRB protocol allowing study of such material provided there was linkage only to diagnostic details such as tumor stage and grade. A separate bank of plasma and fresh frozen tissue, representing a different group of patients and for which written informed consent was required, was obtained from

144 women evaluated for a pelvic mass at the practices of 2 oncologists (J.O.S. and R.S.B.) at the Brigham and Women's Hospital between June 1992 and June 2001, and at the University of Texas Southwestern Medical Center, Dallas, between December 2000 and June 2001. The patients represent a cross-section of women seen in these practices and were selected from those women who consented to the protocol and had non-emergent surgery when technical support to collect the specimens was available. The 144 case patients were divided into those with epithelial ovarian tumors (n=51), other gynecologic cancers (n=47), and benign disease (n=46). All tumor tissue contained less than 20% healthy tissue and was collected from the primary ovarian sites and, if possible, metastatic sites. Control plasma specimens (n=107) were derived from an IRB-approved epidemiologic study of ovarian cancer initiated between May 1992 and March 1997. These controls were selected to match 5-year age groups in cases from 496 plasma specimens still available from an original total of 523 from the epidemiologic study and involved women selected from the general population of Massachusetts and New Hampshire.^{11,12} A match for all 144 case patients was not sought but the number of controls was chosen to be at least twice as large as the number of individuals in the separate case groups.

For fresh-frozen sections, fresh specimens were embedded in Tissue Tek OCT medium (Miles, Elkhart, Ind), snap-frozen in liquid nitrogen, and stored at -80°C until use. The archival tissues in paraffin blocks were retrieved from pathology files in the Laboratory of Gynecologic Oncology at the Brigham and Women's Hospital. The plasma samples were centrifuged at 2000g at 4°C for 15 minutes. The separated plasma was removed, aliquoted, and frozen at -80°C for future analysis.

Laser Capture Microdissection

Tissues stored in Tissue Tek OCT (Miles) medium at -80°C were sectioned at 7 µm in a cryostat (Leica, Allendale, NJ). Sections were mounted on

uncoated glass slides and immediately fixed in 70% and 50% ethanol for 30 seconds in each, stained with hematoxylin-eosin, dehydrated in alcohol solutions of increasing concentration, and cleared in xylene for 5 minutes in each. After being air-dried for 3 minutes, the sections were laser microdissected using the PixCell II (Arcturus, Calif). Tissue with morphologically healthy ovarian epithelial cells and malignant epithelial ovarian cancer cells was procured, representing 27 cases with ovarian cancer tissue and 2 cases with healthy ovarian tissue. These samples were selected from enrolled cases with sufficient material for study, representing a range of histologic types.

Real-Time Quantitative Reverse Transcription Polymerase Chain Reaction

Real-time quantitative reverse transcription polymerase chain reaction (RT-PCR) was used for analysis of cell cultures and lines and microdissected fresh tissues. Total RNA extraction and cDNA synthesis were performed as described previously.¹³ For the quantitative RT-PCR studies, a total of 2 µL of cDNA was used in a 23-µL PCR mix containing 1X SYBR PCR buffer, 3 mM MgCl₂, 0.8 mM dNTP, and 0.025 U/µL AmpliTaq Gold (PE Applied Biosystems, Foster City, Calif). Amplification was then performed in duplicate using primer sets, which we developed for osteopontin and were manufactured by and purchased from Sigma Genosys (Woodland, Tex) (forward primer: 5'-AAGCGAGGAGTTGAATGTGCAT-3'; reverse primer: 5'-TGTGGGTTTCAGCACTCTGCTTCAT-3') and a housekeeping gene, glyceraldehyde-3-phosphate dehydrogenase (GAPDH), as a control in an ABI PRISM 5700 Sequence Detector (PE Applied Biosystems) with denaturation for 10 minutes at 95°C followed by 40 PCR cycles of denaturation at 95°C for 15 seconds and annealing or extension at 60°C for 1 minute. The ABI5700 system software monitored the changes in fluo-

rescence of SYBR Green I dye in every cycle. The threshold cycle (C_T) value for each reaction, reflecting the amount of PCR needed to identify a target gene, and the relative level of osteopontin for each sample were calculated as described.¹³⁻¹⁵ Briefly, *GAPDH* was used for the normalization of the quantity of RNA used. Its C_T value was then subtracted from that of the osteopontin gene to obtain a ΔC_T value. The difference ($\Delta\Delta C_T$) between the ΔC_T values of the samples for the gene target and the ΔC_T value of the calibrator (HOSE697 for cell lines or 741A for tissue) was determined. These calibrators were chosen because they had the lowest expression values for cell lines and tissues, respectively. The relative quantitative value was expressed as $2^{-\Delta\Delta C_T}$, representing the amount of osteopontin expression (normalized to a reference [endogenous]), relative to the calibrators.¹⁵ Specimens were run in duplicate and the values averaged. To confirm the specificity of the PCR reaction, PCR products were electrophoresed on a 1.2% agarose gel.

Immunohistochemistry

The paraffin block specimens used in this experiment were derived from archived tissue (not representing samples from patients contributing fresh specimens) and consisted of tissue from 3 healthy ovaries, 6 benign ovarian tumors (1 serous, 4 mucinous, and 1 mixed), 29 borderline ovarian cancers (13 serous, 14 mucinous, 1 clear cell, and 1 mixed), and 61 invasive ovarian cancers (21 serous, 21 mucinous, 6 endometrioid, 8 clear cell, 2 undifferentiated, and 3 mixed). The archived paraffin blocks were derived from patients having surgery at the Brigham and Women's Hospital. Blocks were selected to represent a cross-section of histologic types and grades, overselecting for early-stage cases. There were 42 blocks containing International Federation of Gynecology and Obstetrics (FIGO) stage I/II tumor and 33 blocks with stage III/IV tumor included in immunohistochemical studies.

Immunohistochemical studies were performed using the avidin-biotin

method, as described previously.¹³ Sections were incubated with primary mouse monoclonal antibody directed against osteopontin (2 $\mu\text{g}/\text{mL}$) for 60 minutes at 37°C (Immuno-Biological Laboratories [IBL], Gumma, Japan). The control sections were treated in parallel but incubated with normal mouse serum (as a negative control) instead of the primary antibody. All sections were incubated in a moist chamber. Sections were then incubated with a biotinylated secondary antibody for 30 minutes (Vector Laboratories, Burlingame, Calif). After 30 minutes of incubation in avidin-biotin complex, the reaction product was visualized by 3,3'-diaminobenzidine tetrahydrochloride (Vector Laboratories). Finally, sections were dehydrated and cleared in ethanol and xylene and mounted in SP15-500 Permount (Fisher Scientific, Pittsburgh, Pa). Representative photomicrographs were recorded by a digital camera (Optronix, Goleta, Calif). Intensity of staining was quantified using a semiquantitative scoring system as described.¹⁶

Enzyme-Linked Immunosorbent Assay

Levels of osteopontin in plasma samples were measured with a solid-phase sandwich enzyme-linked immunosorbent assay (ELISA) using a commercially available kit, which has interassay coefficient of variation varying from 0.7% to 2.0% and intraassay coefficient of variation varying from 3.7% to 4.7% depending on the level of the marker (Code No. 17158, IBL). Microplates were first precoated with anti-human osteopontin rabbit IgG (100 μL of 20 $\mu\text{g}/\text{mL}$ in 0.1-M carbonate buffer; pH, 9.5) and blocked with 1% bovine serum albumin and 0.05% Tween 20. Plasma and standard osteopontin samples were diluted with 1% bovine serum albumin and 0.05% Tween 20 in phosphate-buffered saline and incubated for 1 hour at 37°C. After 7 washes with 0.05% Tween 20 in phosphate buffer, horseradish peroxidase-labeled conjugated anti-human osteopontin (10A16) mouse monoclonal an-

tibody (100 μL of 2 ng/mL) was added and incubated for 30 minutes at 4°C. After 9 washes, 100 μL of tetramethyl benzidine buffer was added and the signal was allowed to develop for 30 minutes at room temperature. The reaction was stopped with 100 μL of 1 N sulfuric acid. The absorbance at 450 nm was measured by an automatic ELISA reader (Biorad, Hercules, Calif).

Results were converted from the mean absorbance of duplicate wells after subtraction of background values. Recombinant human osteopontin protein (IBL) was used as a standard. The standard curve was prepared simultaneously with the measurement of test samples. Reagent blank, test sample blank, and internal controls of plasma samples were used to normalize osteopontin values obtained from each experiment.

Statistical Analysis

The relative measures of osteopontin expression, $2^{-\Delta\Delta C_T}$, as measured using RT-PCR in cancer and healthy cells or cancer and healthy tissue were compared with unpaired *t* tests on log-transformed values. Immunohistochemistry scores were compared using the nonparametric Kruskal-Wallis test for overall group differences. Osteopontin has plasma levels that range over multiple orders of magnitude; therefore, a logarithmic transformation was used to change to an arithmetic scale. Simultaneously, the transformed data complied more accurately with the assumptions of a Gaussian distribution for residuals in general linear models. Data were summarized with the number of observations, the geometric mean (*P* values were applied appropriately to differences in the log [osteopontin] levels), the 95% confidence intervals (CIs) for the geometric mean, and the range of the data. The general linear model was used to determine differences in means among groups (eg, diagnostic groups or within ovarian cancers for the histologic groups) and age was added to the model to adjust for any age effects on osteopontin levels. The ELISA levels were compared using the Kruskal-Wallis test

OSTEOPONTIN AS A POTENTIAL BIOMARKER

or Mann-Whitney *U* test among groups. The level of critical significance was considered to be $P < .05$.

For reporting specificity and sensitivity estimates, there are a variety of arbitrary choices, including present-

ing the full receiver operating characteristic curve, or fixing sensitivity at an arbitrary value and estimating the specificity, or fixing specificity at an arbitrary value and estimating sensitivity. The latter choice was made for this re-

port with a choice of specificity of 80%. First, the nearest cutoff for osteopontin corresponding to this level of specificity is determined, then the sensitivity is estimated as the number of patients with disease for a given subgroup with osteopontin levels exceeding the cutoff divided by the number of patients with disease in the given subgroup. The actual specificity may vary slightly from the target value ($80\% = 4/5$) because the number of case patients is not (in this study) divisible by 5. All analyses were performed using SPSS version 9.0 (SPSS Inc, Chicago, Ill) and S-PLUS (Insightful Inc, Seattle, Wash).

RESULTS

To validate overexpression of osteopontin in ovarian cancer, real-time RT-PCR was applied to an expanded series of ovarian epithelial cell cultures and cancer cell lines and tissues. Based on the $\Delta\Delta C_T$ relative to the healthy cell culture, HOSE697, the relative expression levels of osteopontin messenger RNA (mRNA) in other cell lines were calculated (FIGURE 1). The geometric means of healthy and cancer cell lines were 4.1 and 270.4 ($P = .03$). Except for CAO3, OVCA3, OVCA429, and ES-2,

Figure 1. Relative Quantitation of Osteopontin in Healthy Ovarian Epithelial Cell Cultures and Malignant Ovarian Epithelial Cancer Cell Lines

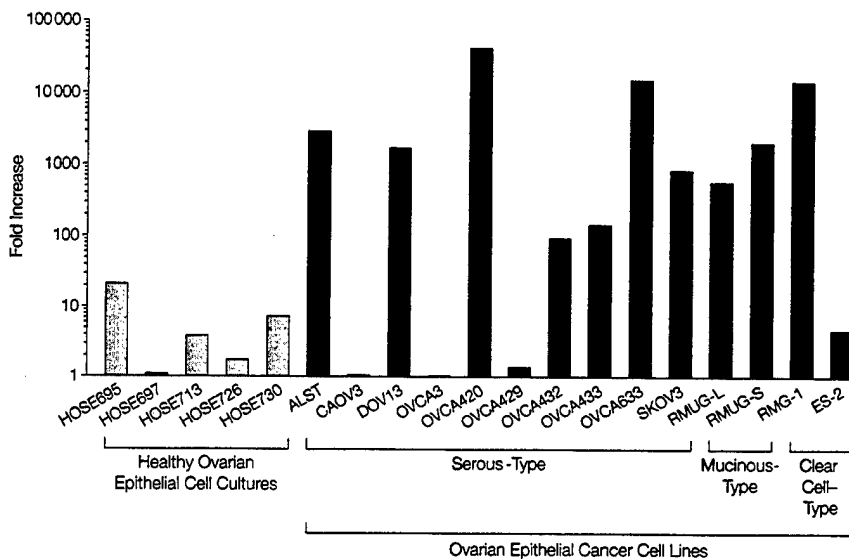

Statistically significant differences were obtained between 5 healthy human ovarian surface epithelial (HOSE) cell cultures, 10 serous-type ovarian cancer cell lines, 2 mucinous-type ovarian cancer cell lines, and 2 clear cell-type ovarian cancer cell lines by unpaired *t* test ($P = .03$). Each value was expressed as the mean of duplicate. The referent was HOSE697, considered to have a value of 1.

Figure 2. Relative Quantitation of Osteopontin in Healthy Ovarian Epithelial Tissues and Malignant Ovarian Epithelial Cancer Tissues

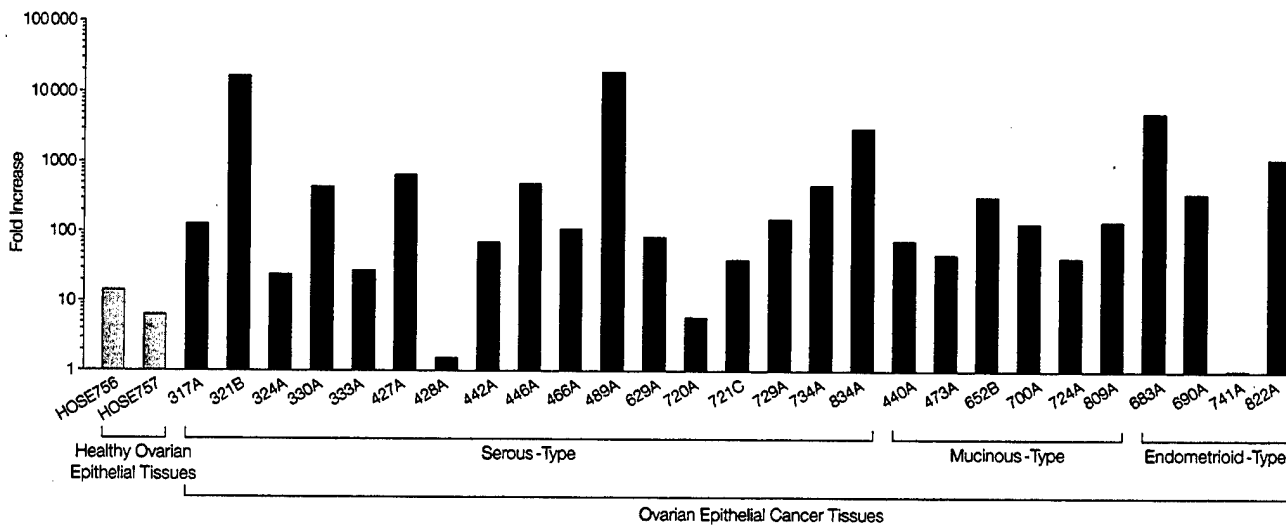

Expression differences were obtained between samples of 2 healthy ovarian epithelial tissues, 17 serous-type ovarian cancer tissues, 6 mucinous-type ovarian cancer tissues, and 4 endometrioid-type ovarian cancer tissues by unpaired *t* test ($P = .06$). Each value was expressed as the mean of duplicate. The referent was 741A, considered to have a value of 1.

the other 10 ovarian cancer cell lines showed high levels of osteopontin expression. There was no significant difference in osteopontin expression among cell lines derived from different histologic subtypes (Figure 1).

Osteopontin expression in microdissected ovarian cancer tissues was also examined using real-time RT-PCR with 741A as the reference. Higher osteopontin expression in the 27 ovarian cancer tissues was observed compared with expression in the 2 samples of healthy ovarian surface epithelium. The geometric mean of the 2 groups was 9.0 and 164.0 with logarithmic transformation, respectively. The statistical difference was nonsignificant, perhaps due to the limited number of healthy samples examined ($P = .06$). There was no significant difference in osteopontin expression among tumors of different subtypes (FIGURE 2).

Osteopontin protein levels in paraffin block sections of 3 healthy tissues, 6 benign ovarian tumors, 29 borderline ovarian cancers, and 61 invasive ovarian cancers were assessed via immunohistochemistry studies. Osteopontin immunoreactivity was not observed in epithelium and stroma of the healthy ovarian tissues (score 0). Most positive staining observed in cancer tissues was localized to the cellular membrane and cytoplasm, extracellular matrix component, or psammoma bodies with some variations by histologic subtypes. Serous types mainly showed immunopositivity in psammoma bodies with occasional or focal cytoplasmic staining. Immunopositivity in mucinous type was localized to the cytoplasmic, especially pericytoplasmic, region. Abundantly stained extracellular materials suggested that osteopontin was secreted from mucinous ovarian cancer cells. Endometrioid and clear cell subtypes showed focal cytoplasmic localization (FIGURE 3).

The immunostaining scores in tissue sections from healthy ovary, benign ovarian tumor, borderline ovarian tumor, and invasive ovarian cancer were 0.0 (95% CI, 0.0-0.0), 0.7 (95% CI, 0.0-1.8), 2.2 (95% CI, 1.5-2.9), and 2.1 (95% CI, 1.7-

2.6), respectively (TABLE 1). The difference among diagnostic groups was statistically significant ($P = .03$) as well as the differences among histologic groups ($P = .01$) with mucinous cases having higher expression. Among the cancer (borderline and invasive) group, there was no significant difference in osteopontin immunoreactivity among different grades and stages.

Finally, we examined osteopontin levels in plasma samples obtained from 107 healthy controls, 46 patients with benign disease, 47 patients with gynecologic cancers other than ovarian cancers, and 51 patients with ovarian cancer using ELISA. The mean ages for the groups by category were 50.8 years for healthy, 54.6 years for benign disease, 50.9 years for other

Figure 3. Immunolocalization of Osteopontin in Healthy and Malignant Ovarian Tissues

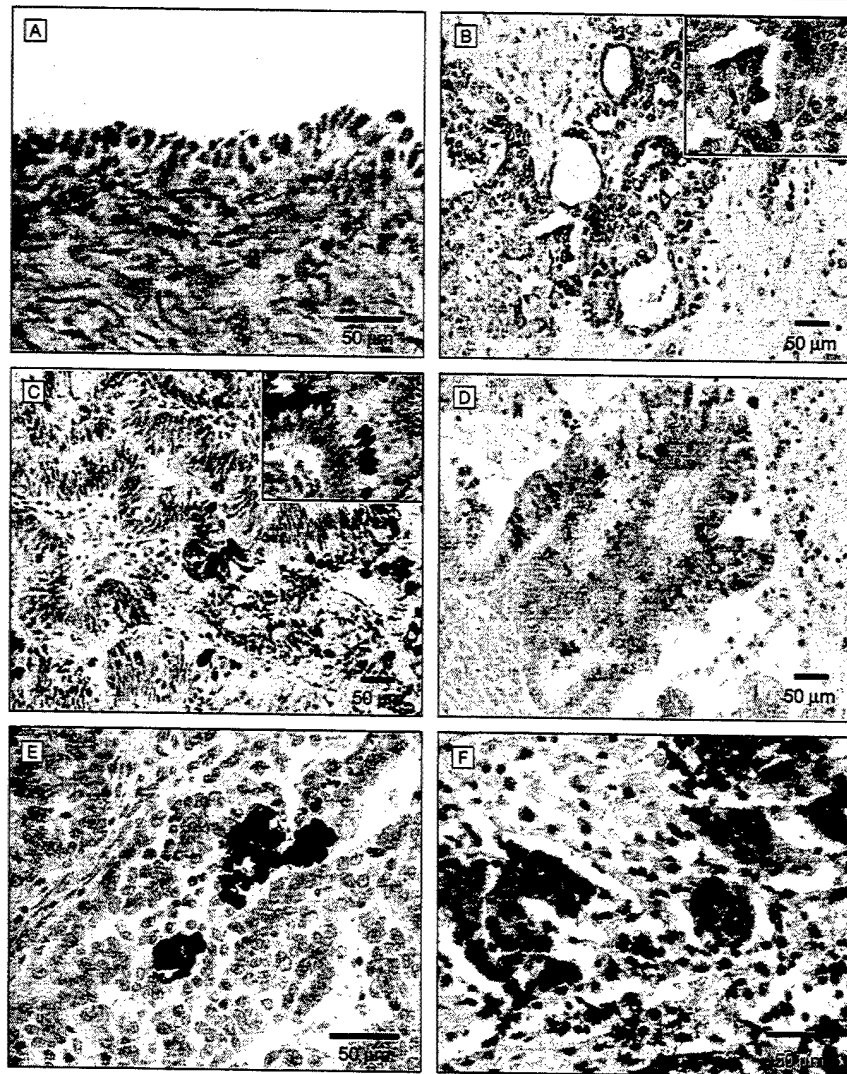

Osteopontin expression is indicated by brown staining and was immunolocalized using an anti-osteopontin monoclonal antibody and an avidin-biotin peroxidase complex method with diaminobenzidine as the chromogen. The sections were counterstained with hematoxylin. A, Healthy ovarian surface epithelial cells with no expression of osteopontin. B, Endometrioid cystadenocarcinoma with osteopontin expression in cancer cells. C, Borderline mucinous tumor with osteopontin expression in cell membrane and cytoplasmic area. D, Invasive mucinous cystadenocarcinoma. E, Serous cystadenocarcinoma with osteopontin expression in psammoma body. F, Serous cystadenocarcinoma with osteopontin expression in cancer cells.

Table 1. Expression of Osteopontin in Relation to Histopathologic Characteristics in Immunohistochemical Analyses*

Characteristics	No. of Patients	Scores		P Value
		Geometric Mean (95% Confidence Interval)	Range	
All patients	99	2.0 (1.7-2.4)	0-6	
Diagnostic category				
Healthy	3	0.0 (0.0-0.0)	0-0	.03
Benign	6	0.7 (0.0-1.8)	0-2	
Borderline	29	2.2 (1.5-2.9)	0-6	
Invasive	61	2.1 (1.7-2.6)	0-6	
Histology of cancer				
Serous	34	1.3 (0.8-1.9)	0-4	.01
Mucinous	35	3.0 (2.4-3.6)	0-6	
Endometrioid	5	2.2 (0.0-4.4)	0-5	
Clear cell	10	2.3 (1.1-3.5)	0-6	
Undifferentiated	2	1.0 (0.0-6.0)	0-2	
Mixed	4	2.3 (1.5-3.1)	2-3	
Tumor differentiation†				
Borderline	28	2.2 (1.5-2.9)	0-6	.45
Well	11	2.6 (1.2-4.1)	0-6	
Moderate	17	2.1 (1.2-3.0)	0-6	
Poor	19	1.5 (0.9-2.2)	0-4	
FIGO stage†				
I	36	2.2 (1.7-2.8)	0-6	.16
II	6	2.7 (0.0-5.3)	0-6	
III	30	2.0 (1.3-2.6)	0-6	
IV	3	0.0 (0.0-0.0)	0-0	

*FIGO indicates International Federation of Gynecology and Obstetrics. The scoring system used corresponded to the sum of both staining intensity (3+, strong positive stain in most cells; 2+, moderate stain in cells; 1+, weak stain in cells; 0, no evidence of stain) and percentage of positive cells (3+, most of described cells stained; 2+, half of cells stained; 1+, few cells stained; 0, no cells stained).¹⁶ Differences between groups were evaluated by the sum of intensity and cell count scores in each. P values were for overall group differences.

†There were 15 cases that could not be categorized.

gynecologic cancers, and 55.4 years for ovarian cancer. Because the age difference between the ovarian cancer patients and healthy controls was marginally significant ($P=.04$), P values for the differences among mean (logarithm) osteopontin levels are presented from linear models that include a term for age.

The mean osteopontin level for all of the patients was 230.9 ng/mL (95% CI, 130.2-409.3 ng/mL) and in the categories of healthy controls, benign disease, other gynecologic cancers, and ovarian cancer, the mean levels were 147.1 ng/mL (95% CI, 99.4-217.7 ng/mL), 254.4 ng/mL (95% CI, 148.2-436.7 ng/mL), 260.9 ng/mL (95% CI, 127.8-532.7 ng/mL), and 486.5 ng/mL (95% CI, 315.0-751.4 ng/mL), respectively (FIGURE 4). The difference in osteopontin level between ovarian cancer cases and healthy controls was

statistically significant ($P<.001$) (TABLE 2). There were no significant differences among histologic types ($P=.11$), different histologic grades ($P=.26$), and stages ($P=.17$) of ovarian cancer (Table 2).

Using a cutoff value of 252 ng/mL, the specificity was 80.4% and the sensitivity point estimates for the detection of early-stage (I/II) and late-stage (III/IV) ovarian cancer were 80.4% and 85.4%, respectively.

COMMENT

Because of the tendency for ovarian cancer to produce clinical symptoms at a late stage, there is a need for better early detection methods. Although a number of tumor markers have been identified and studied for ovarian cancer,¹⁷⁻²² a useful screening marker for ovarian cancer has not been clearly established. The most widely re-

searched marker, CA125, has shown some value in postmenopausal women in pilot screening studies but sensitivity for early-stage disease before clinical detection remains questionable.²³ Thus, a marker of advanced disease may not translate well to identification of early asymptomatic disease.

One approach to meeting the need for new markers is the use of cDNA microarray technology to identify up-regulating genes in ovarian cancer cells or tissues. Previously, we described the cDNA MICROMAX microarray system to identify up- or down-regulated genes in ovarian cancer using RNA pooled from several healthy HOSE cell cultures and ovarian cancer cell lines.⁶ We described herein the additional studies necessary to establish the potential clinical relevance of one of the markers identified, osteopontin.

Osteopontin is an acidic, calcium-binding glycoprophosphoprotein that is found in all body fluids and in the extracellular matrix components.²⁴⁻²⁹ The molecular weight is 44 kd to 66 kd, depending on species and cell types.²⁴⁻²⁹ Osteopontin has been referred to as pp69, 44-kd bone phosphoprotein, 2ar, Eta-1, transformation associated phosphoprotein 1, and 2B7.²⁴⁻²⁹ It can function both as a cell adhesion protein and as a cytokine for several integrins and CD44.^{30,31} Furthermore, it has been shown to be involved in inflammation, especially in regulation of macrophages,³²⁻³⁷ tumorigenesis,^{28,38-45} and dystrophic calcification.^{39-41,46}

To further examine osteopontin's clinical potential, it was first necessary to show that osteopontin is expressed in individual cell lines and in actual cancer tissue. A technique involving real-time RT-PCR was used to measure gene expression in cells or tissue. Our study demonstrated that osteopontin was expressed in a number of ovarian cancer cell lines different from the ones previously used in the microarray experiment.⁶ We next used real-time RT-PCR with actual ovarian cancer tissue to demonstrate that expression was not an artifact associated with the culturing of ovar-

ian cancer cells in vitro. Real-time RT-PCR applied to microdissected ovarian cancer tissue also demonstrated increased osteopontin mRNA expression in the cancer tissue compared with healthy tissue, though the difference was not statistically significant. Another method for demonstrating expression is to use immunohistochemical studies to examine protein expression assessed through staining of tumor or healthy ovarian tissue. This technique offers the advantage of being able to use material archived in tumor blocks but does require the existence of an antibody to the overexpressed protein, which in this case was available.

Our immunohistochemistry results suggested that different histologic subtypes of ovarian cancer have different osteopontin expression patterns. In serous ovarian cancer, high levels of osteopontin were localized to the psammoma bodies, which are laminated calcified concretions commonly found in serous cancers. Curiously, the cancer cells expressed low levels of osteopontin protein, yet the real-time RT-PCR data on cell lines and microdissected tumors showed relatively high levels of osteopontin mRNA in the majority of samples of serous cancer cells. The discrepancy between osteopontin mRNA and protein levels may be explained by the fact that osteopontin protein may be actively secreted by serous epithelial cancer cells and, subsequently, translocated to the psammoma bodies resulting in calcium phosphate deposition. Recently, osteopontin mRNA has also been detected in CD68 protein macrophages infiltrating serous ovarian cancer tissues,⁴⁰ suggesting that tumor-infiltrating macrophages may also secrete osteopontin and are involved in the generation of psammoma bodies in serous cancers. A recent study of osteopontin expression in 16 serous borderline ovarian tumors and 14 serous invasive ovarian carcinomas showed a significantly higher level of expression in borderline tumors than carcinomas, suggesting that osteopontin may be impor-

tant for the pathogenesis of serous borderline tumors.⁴¹

In contrast to serous-type ovarian cancer, higher osteopontin protein levels were detected in the cytoplasm of mucinous-type ovarian cancer cells, suggesting active osteopontin protein synthesis in these cells. Different osteopontin expression patterns in different histologic subtypes of cancer have also been described in lung and esophageal cancers.^{47,48} Osteopontin overexpression has been demonstrated in immunohistochemical studies of a number of other cancers including cancer of prostate, breast, and stomach.⁴¹⁻⁴⁵

Clearly, any proposed tumor marker must be identifiable in blood or other readily accessed biological samples. Using ELISA, we measured osteopontin levels in preoperative plasma from patients with epithelial ovarian cancer and plasma from healthy controls. Preoperative osteopontin levels were significantly higher in women with ovarian cancer compared with those in women not having ovarian cancer or those with benign pelvic disease. In addition, osteopontin levels were significantly

higher in patients with ovarian cancer than in patients with other types of gynecologic cancers (cervix and endometrium). We also observed no significant difference in osteopontin levels as

Figure 4. Osteopontin Levels in Case Patients Within 4 Diagnostic Categories

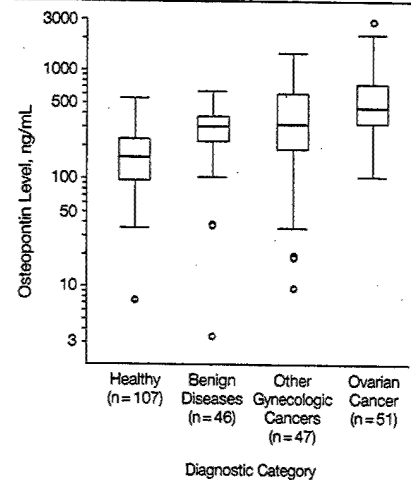

The box is bounded above and below by the 75th and 25th percentiles and the median is the line in the box. Whiskers are drawn to the nearest value not beyond a standard span from the quartiles; points beyond (outliers) are drawn individually, where the standard span is 1.5 × (interquartile range).

Table 2. Preoperative Osteopontin Levels in Patients With Ovarian Cancer vs Those of Controls and Patients With Benign or Other Gynecologic Disease*

Characteristics	No. of Patients	Osteopontin Level, ng/mL		P Value
		Geometric Mean (95% Confidence Interval)	Range	
All patients	251	230.9 (130.2-409.3)	3.4-2859.8	
Diagnostic category				<.001
Healthy	107	147.1 (99.4-217.7)	7.5-547.9	
Benign disease	46	254.4 (148.2-436.7)	3.4-640.8	
Other gynecologic cancers	47	260.9 (127.8-532.7)	9.7-1453.4	
Ovarian cancer	51	486.5 (315.0-751.4)	105.1-2859.8	
Histology of cancer				.11
Serous	31	451.6 (293.1-682.8)	105.1-1588.2	
Mucinous	3	384.0 (290.6-507.5)	274.6-640.2	
Endometrioid	5	379.4 (261.2-551.1)	210.1-843.9	
Clear cell	1	2130.5 (NA)	2130.5-2130.5	
Undifferentiated	3	538.0 (342.5-845.1)	250.4-1068.4	
Mixed	8	526.5 (357.2-776.1)	297.9-2166.0	
Tumor differentiation				.26
Borderline/well	10	373.9 (280.3-498.7)	210.1-843.9	
Moderate/poor	41	493.6 (321.6-757.5)	105.1-2166.0	
FIGO stage				.17
I/II	10	369.7 (279.8-488.5)	210.1-843.9	
III/IV	41	520.1 (329.0-822.3)	105.1-2859.8	

*NA indicates not applicable; FIGO, International Federation of Gynecology and Obstetrics. P values were calculated with analysis of variance performed on the logarithms of plasma osteopontin level data, including a term for age.

assessed via ELISA among serous, mucinous, clear cell, and endometrioid types of ovarian cancer, suggesting that osteopontin may be useful in detecting most subtypes of ovarian cancer. We believe preoperative sensitivity estimates may be sufficiently high to encourage pilot clinical screening studies, which would include osteopontin in a panel of putative early detection markers to obtain estimates of screening sensitivity and specificity. The crucial issue to be addressed is the sensitivity of a panel of biomarkers for detecting early-stage ovarian cancer or for screening subjects who would have been clinically detected in late-stage disease. Sensitivity estimates based on preoperative samples from clinically detected patients, either early- or late-stage disease, are no substitute for estimates obtained from prospectively conducted clinical trials and are at best a guide as to which markers to test in such a trial.

In conclusion, this investigation has demonstrated the potential value of the cDNA microarray analysis in identifying overexpressed genes in ovarian cancer and its subsequent link to a protein measurable in plasma. The findings suggest evidence for an association between plasma levels of osteopontin and ovarian cancer, pointing to a rationale for further research assessing potential clinical usefulness.

Author Affiliations: Department of Obstetrics and Gynecology, Saint Vincent Hospital and Catholic University of Korea, Suwon, Kyong-Ki-Do, Korea (Dr Kim); Department of Obstetrics, Gynecology, and Reproductive Biology, Brigham and Women's Hospital and Harvard Medical School (Drs Kim, Feltmate, Berkowitz, Cramer, and Mok); Massachusetts General Hospital Biostatistics Center and Harvard Medical School (Dr Skates); Dana-Farber Cancer Institute (Drs Skates, Berkowitz, and Cramer), and Dana-Farber Harvard Cancer Center (Drs Skates, Berkowitz, Cramer, and Mok), Boston, Mass; Institute for Genetic Medicine, Hokkaido University, Sapporo, Hokkaido, Japan (Dr Uede); Department of Pediatrics, Texas Children's Cancer Center, Baylor College of Medicine, Houston (Dr Wong); Department of Obstetrics and Gynecology, University of Texas Southwestern Medical Center, Dallas (Dr Schorge).

Financial Disclosures: Dr Skates received funding from Cancer Genetics Network, Early Detection Research Network, and Ovarian Specialized Program On Research Excellence grants from the National Cancer Institute and from the Medical Research Council for the UK Collaborative Trial of Ovarian Cancer Screening, received one-time honoraria from the Society for Gynecologic Oncology (for a continuing medical edu-

cation program), Becton-Dickinson, and diaDexus, is on the Clinical Advisory Team for Atairgin, and is a coapplicant on US patent application No. 09/948,094 based on work described in this study; Dr Uede received research grant funding (project non-specified) from Immuno-Biological Laboratories (IBL) Co, Ltd, which distributed the ELISA kits used in this study, and he evaluated the ELISA kits used in this study during the time they were being developed, submitted patents for the osteopontin detection kits developed by IBL (antibody and ELISA) jointly with IBL, and received Japanese government grants for the development of the ELISA kit for measuring osteopontin; Dr Wong was a coapplicant on patent application No. 09/948,094; Dr Schorge had an active research grant from The Berlex Foundation for a molecular study of cervical adenocarcinoma and a research award from ACOG/Ortho-McNeil for investigation of peritoneal cancer, received one-time lecture honoraria from Cytoc Corp, and received continuing medical education honoraria from the Southwestern Gynecologic Assembly for lecturing on hereditary gynecological cancers; Dr Cramer has received honoraria for speeches from Wyeth-Ayerst, GlaxoSmithKline, and Serono and was a coapplicant on patent application No. 09/948,094; Dr Mok filed patent application No. 09/948,094 based on the work described in this study. **Author Contributions:** Study concept and design: Kim, Wong, Mok.

Acquisition of data: Kim, Uede, Schorge, Feltmate, Berkowitz, Cramer, Mok.

Analysis and interpretation of data: Kim, Skates, Berkowitz, Cramer, Mok.

Drafting of the manuscript: Kim, Skates, Uede, Berkowitz, Cramer, Mok.

Critical revision of the manuscript for important intellectual content: Skates, Wong, Schorge, Feltmate, Berkowitz, Cramer, Mok.

Statistical expertise: Kim, Skates.

Obtained funding: Cramer, Mok.

Administrative, technical, or material support: Wong, Schorge, Feltmate, Berkowitz, Cramer, Mok.

Study supervision: Mok.

Funding/Support: This study was partly supported by the Early Detection Research Network Grant CA86381 from the National Institutes of Health, the Gillette Center For Women's Cancer, the Adler Foundation Inc, the Ovarian Cancer Research Fund Inc, the Morse Family Fund, the Natalie Pihl Fund, and the Ruth N. White Research Fellowship.

Acknowledgment: We thank all the patients for their participation in the study.

REFERENCES

- Greenlee RT, Murray T, Bolden S, Wingo PA. Cancer statistics. *CA Cancer J Clin*. 2000;50:7-33.
- Landis SH, Murray T, Bolden S, Wingo PA. Cancer statistics, 1999. *CA Cancer J Clin*. 1999;49:8-31.
- Ries LA, Kosary CL, Hankey BF, et al. *SEER Cancer Statistic Review, 1973-1995*. Bethesda, Md: National Cancer Institute; 1998.
- Sgroi DC, Teng S, Robinson G, et al. In vivo gene expression profile analysis of human breast cancer progression. *Cancer Res*. 1999;59:5656-5661.
- Villaret DB, Wang T, Dillon D, et al. Identification of genes overexpressed in head and neck squamous cell carcinoma using a combination of complementary DNA subtraction and microarray analysis. *Laryngoscope*. 2000;110:374-381.
- Wong KK, Cheng RS, Mok SC. Identification of differentially expressed genes from ovarian cancer cells by MICROMAX cDNA microarray system. *Biotechniques*. 2001;30:670-675.
- Bull JH, Ellison G, Patel A, et al. Identification of potential diagnostic markers of prostate cancer and prostatic intraepithelial neoplasia using cDNA microarray. *Br J Cancer*. 2001;84:1512-1519.
- Kononen J, Bubendorf L, Kallioniemi A, et al. Tissue microarrays for high-throughput molecular profiling of tumor specimens. *Nat Med*. 1998;4:844-847.
- Dhanasekaran SM, Barrette TR, Ghosh D, et al. Delineation of prognostic biomarkers in prostate cancer. *Nature*. 2001;412:822-826.
- Tsao SW, Mok SC, Fey EG, et al. Characterization of human ovarian surface epithelial cells immortalized by human papilloma viral oncogenes (HPV-E6E7 ORFs). *Exp Cell Res*. 1995;218:499-507.
- Cramer DW, Kuper H, Harlow BL, Titus-Ernstoff L. Carotenoids, antioxidants and ovarian cancer risk in pre- and postmenopausal women. *Int J Cancer*. 2001;94:128-134.
- Cramer DW, Greenberg ER, Titus-Ernstoff L, et al. A case-control study of galactose consumption and metabolism in relation to ovarian cancer. *Cancer Epidemiol Biomarkers Prev*. 2000;9:95-101.
- Mok SC, Chao J, Skates S, et al. Prostatin, a potential serum marker for ovarian cancer. *J Natl Cancer Inst*. 2001;93:1458-1464.
- Heid CA, Stevens J, Livak L, Williams IM. Real time quantitative PCR. *Genome Res*. 1996;6:986-994.
- Absolute and relative quantitation. In: *Gene-Amp 5700 User's Manual*. Foster City, Calif: PE Applied Biosystems; 1998:9A-A11.
- Chan WY, Cheung KK, Schorge JO, et al. Bcl-2 and p53 protein expression, apoptosis, and p53 mutation in human epithelial ovarian cancers. *Am J Pathol*. 2000;156:409-417.
- Xu Y, Shen Z, Wiper DW, et al. Lysophosphatidic acid as a potential biomarker for ovarian and other gynecologic cancers. *JAMA*. 1998;280:719-723.
- Tuxen MK, Soletommos G, Petersen PH, et al. Assessment of biological variation and analytical imprecision of CA 125, CEA, and TPA in relation to monitoring of ovarian cancer. *Gynecol Oncol*. 1999;74:12-22.
- Sandmaier BM, Oparin DV, Holmberg LA, et al. Evidence of a cellular immune response against sialyl-Tn in breast and ovarian cancer patients after high-dose chemotherapy, stem cell rescue, and immunization with Theratope STn-KLH cancer vaccine. *J Immunother*. 1999;22:54-66.
- Luo LY, Katsaros D, Scoria A, et al. Prognostic value of human kallikrein 10 expression in epithelial ovarian carcinoma. *Clin Cancer Res*. 2001;7:2372-2379.
- Negishi Y, Iwabuchi H, Sakunaga H, et al. Serum and tissue measurements of CA72-4 in ovarian cancer patients. *Gynecol Oncol*. 1993;48:148-154.
- Hogdall CK, Mogensen O, Tabor A, et al. The role of serum tetranectin, CA 125, and a combined index as tumor markers in women with pelvic tumors. *Gynecol Oncol*. 1995;56:22-28.
- Jacobs IJ, Skates SJ, MacDonald N, et al. Screening for ovarian cancer: a pilot randomised controlled trial. *Lancet*. 1999;353:1207-1210.
- Chackalaparampil I, Banerjee D, Poirier Y, Mukherjee BB. Altered processing of a major secreted phosphoprotein correlates with tumorigenicity in Rous sarcoma virus-transformed mammalian cells. *J Virol*. 1985;53:841-850.
- Prince CW, Oosawa T, Butler WT, et al. Isolation, characterization, and biosynthesis of a phosphorylated glycoprotein from rat bone. *J Biol Chem*. 1987;262:2900-2907.
- Smith JH, Denhardt DT. Molecular cloning of a tumor promoter-inducible mRNA found in JB6 mouse epidermal cells: induction is stable at high, but not at low, cell densities. *J Cell Biochem*. 1987;34:13-22.
- Patarca R, Freeman GJ, Singh RP, et al. Structural and functional studies of the early T lymphocyte activation 1 (*Eta-1*) gene. *J Exp Med*. 1989;170:145-161.
- Senger DR, Perruzzi CA, Papadopoulos A. Elevated expression of secreted phosphoprotein 1 (osteopontin, 2ar) as a consequence of neoplastic transformation. *Anticancer Res*. 1989;9:1291-1299.
- Giachelli C, Bae N, Lombardi D, et al. Molecular cloning and characterization of 2B7, a rat mRNA which

- distinguishes smooth muscle cell phenotypes in vitro and is identical to osteopontin (secreted phosphoprotein 1, 2aR). *Biochem Biophys Res Commun*. 1991; 177:867-873.
30. Liaw L, Skinner MP, Raines EW, et al. The adhesive and migratory effects of osteopontin are mediated via distinct cell surface integrins. *J Clin Invest*. 1995;95:713-724.
31. Weber GF, Ashkar S, Glimcher MJ, Cantor H. Receptor-ligand interaction between CD44 and osteopontin (*Eta-1*). *Science*. 1996;271:509-512.
32. Giachelli CM, Lombardi D, Johnson RJ, et al. Evidence for a role of osteopontin in macrophage infiltration in response to pathological stimuli in vivo. *Am J Pathol*. 1998;152:353-358.
33. Crawford HC, Matrisian LM, Liaw L. Distinct roles of osteopontin in host defense activity and tumor survival during squamous cell carcinoma progression in vivo. *Cancer Res*. 1998;58:5206-5215.
34. Nau GJ, Guilfoile P, Chupp GL, et al. A chemoattractant cytokine associated with granulomas in tuberculosis and silicosis. *Proc Natl Acad Sci U S A*. 1997; 94:6414-6419.
35. Singh RP, Patarca R, Schwartz J, et al. Definition of a specific interaction between the early T lymphocyte activation 1 (*Eta-1*) protein and murine macrophages in vitro and its effect upon macrophages in vivo. *J Exp Med*. 1990;171:1931-1942.
36. Hwang SM, Lopez CA, Heck DE, et al. Osteopontin inhibits induction of nitric oxide synthase gene expression by inflammatory mediators in mouse kidney epithelial cells. *J Biol Chem*. 1994;269:711-715.
37. McKee MD, Nanci A. Secretion of osteopontin by macrophages and its accumulation at tissue surfaces during wound healing in mineralized tissues. *Anat Rec*. 1996;245:394-409.
38. Shijubo N, Uede T, Kon S, et al. Vascular endothelial growth factor and osteopontin in stage I lung adenocarcinoma. *Am J Respir Crit Care Med*. 1999; 160:1269-1273.
39. Tunio GM, Hirota S, Nomura S, Kitamura Y. Possible relation of osteopontin to development of psammoma bodies in human papillary thyroid cancer. *Arch Pathol Lab Med*. 1998;122:1087-1090.
40. Maki M, Hirota S, Kaneko Y, Morohoshi T. Expression of osteopontin messenger RNA by macrophages in ovarian serous papillary cystadenocarcinoma. *Pathol Int*. 2000;50:531-535.
41. Tiniakos DG, Yu H, Liapis H. Osteopontin expression in ovarian carcinomas and tumors of low malignant potential (LMP). *Hum Pathol*. 1998;29:1250-1254.
42. Thalmann GN, Sikes RA, Devoll RE, et al. Osteopontin: possible role in prostate cancer progression. *Clin Cancer Res*. 1999;5:2271-2277.
43. Kim YW, Park YK, Lee J, et al. Expression of osteopontin and osteonectin in breast cancer. *J Korean Med Sci*. 1998;13:652-657.
44. Tuck AB, O'Malley FP, Singhal H, et al. Osteopontin expression in a group of lymph node negative breast cancer patients. *Int J Cancer*. 1998;79:502-508.
45. Ue T, Yokozaki H, Kitadai Y, et al. Co-expression of osteopontin and CD44v9 in gastric cancer. *Int J Cancer*. 1998;79:127-132.
46. Giachelli CM, Liaw L, Murry CE, et al. Osteopontin expression in cardiovascular diseases. *Ann N Y Acad Sci*. 1995;760:109-126.
47. Casson AG, Wilson SM, McCart JA, et al. *ras* mutation and expression of the *ras*-regulated genes osteopontin and cathepsin L in human esophageal cancer. *Int J Cancer*. 1997;72:739-745.
48. Zhang J, Takahashi K, Takahashi F, et al. Differential osteopontin expression in lung cancer. *Cancer Lett*. 2001;171:215-222.

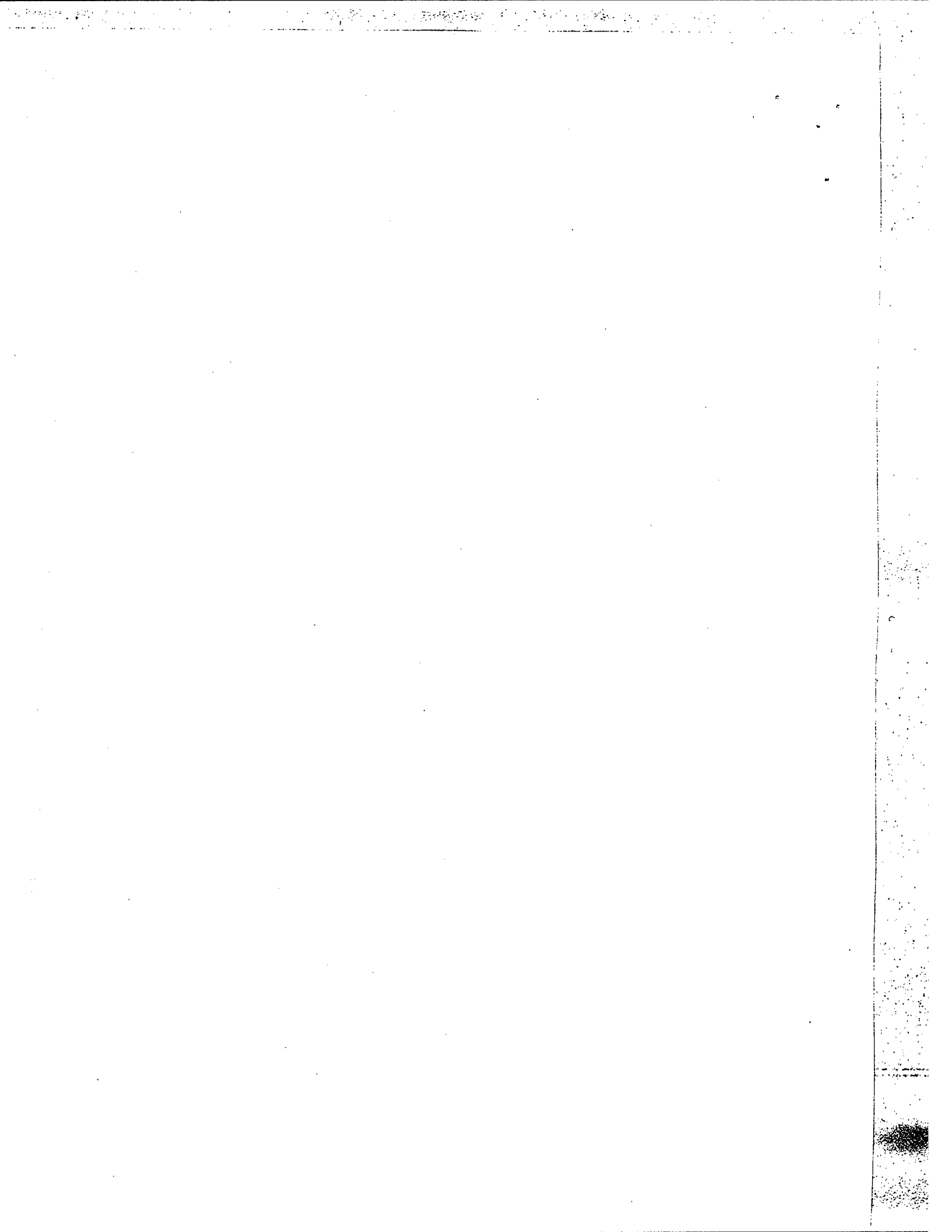

Akt Activation Induced by Lysophosphatidic Acid and Sphingosine-1-phosphate Requires Both Mitogen-Activated Protein Kinase Kinase and p38 Mitogen-Activated Protein Kinase and Is Cell-Line Specific

LINNEA M. BAUDHUIN, KELLY L. CRISTINA, JUN LU, and YAN XU

Departments of Cancer Biology (L.M.B., K.L.C., J.L., Y.X.) and Gynecology and Obstetrics (Y.X.), Cleveland Clinic Foundation, Cleveland, Ohio; and Department of Chemistry, Cleveland State University, Cleveland, Ohio (L.M.B., Y.X.)

Received February 27, 2002; accepted May 28, 2002

This article is available online at <http://molpharm.aspetjournals.org>

ABSTRACT

The signaling pathways that lysophosphatidic acid (LPA) and sphingosine-1-phosphate (S1P) use to activate Akt in ovarian cancer cells are investigated here. We show for the first time, with the use of both pharmacological and genetic inhibitors, that the kinase activity and S473 phosphorylation of Akt induced by LPA and S1P requires both mitogen-activated protein (MAP) kinase kinase (MEK) and p38 MAP kinase, and MEK is likely to be upstream of p38, in HEY ovarian cancer cells. The requirement for both MEK and p38 is cell type- and stimulus-specific. Among 12 cell lines that we tested, 11 respond to LPA and S1P and all of the responsive cell lines require p38 but only nine of them require MEK. Among different stimuli tested, platelet-derived growth factor stimulates S473 phosphorylation of Akt in a MEK- and p38-dependent manner. However, epidermal

growth factor, thrombin, and endothelin-1-stimulated Akt S473 phosphorylation require p38 but not MEK. Insulin, on the other hand, stimulates Akt S473 phosphorylation independent of both MEK and p38 in HEY cells. T308 phosphorylation stimulated by LPA/S1P requires MEK but not p38 activation. MEK and p38 activation were sufficient for Akt S473 but not T308 phosphorylation in HEY cells. In contrast to S1P and PDGF, LPA requires Rho for Akt S473 phosphorylation, and Rho is upstream of phosphatidylinositol 3-kinase (PI3-K). LPA/S1P-induced Akt activation may be involved in cell survival, because LPA and S1P treatment in HEY ovarian cancer cells results in a decrease in paclitaxel-induced caspase-3 activity in a PI3-K/MEK/p38-dependent manner.

LPA and S1P are bioactive lysolipids that exert many of their effects and signaling activities through G protein-coupled receptors (GPCRs) (Goetzl and An, 1998; Moolenaar, 1999; Spiegel, 1999). We have reported previously that both LPA and S1P are important signaling molecules in ovarian cancer, regulating both growth and metastatic potentials of ovarian cancer cells (Xu et al., 1995a,b, 1998, 2001; Hong et al., 1999; Schwartz et al., 2001). We have detected both of these lysolipids in ascitic fluids in patients with ovarian cancer (Xiao et al., 2000, 2001). Moreover, we have reported

that LPA is elevated in the plasma of patients with ovarian cancer but not in that of patients with breast cancer or leukemia, indicating its potential as a marker for ovarian cancer (Xu et al., 1998). LPA has been reported to have a cytoprotective effect in HEY ovarian cancer cells exposed to *cis*-diamminedichloroplatinum (Frankel and Mills, 1996). Furthermore, under certain conditions in vitro, ovarian cancer cells produce LPA (Shen et al., 1998; Eder et al., 2000), suggesting that LPA, and potentially S1P, function as autocrine growth factors in ovarian cancer.

LPA and/or S1P have been shown to activate extracellular signal regulated kinase (ERK) and PI3-K and/or Akt (PKB) via a PTX-sensitive pathway in a number of cell types (Marte and Downward, 1997; Weiner and Chun, 1999; Fang et al.,

This work was supported in part by an American Cancer Society Grant RPG-99-062-01-CNE, U.S. Army Medical Research grant DAMD 17-99-1-9563, and National Institutes of Health Grant R21-CA84038-01 (to Y.X.).

ABBREVIATIONS: LPA, lysophosphatidic acid; S1P, sphingosine-1-phosphate; GPCR, G protein-coupled receptor; ERK, extracellular signal-regulated kinase; PI3-K, phosphatidylinositol 3-kinase; PKB, protein kinase B; PTX, pertussis toxin; MAPK, mitogen-activated protein kinase; MEK, mitogen-activated protein kinase kinase; MK2, mitogen-activated protein kinase-activated protein kinase-2; PDK, 3-phosphoinositide-dependent kinase; ILK, integrin-linked kinase; PIP₃, phosphatidylinositol-3,4,5-trisphosphate; PDGF, platelet-derived growth factor; EGF, epidermal growth factor; Et-1, endothelin-1; PBS, phosphate-buffered saline; LY294002, 2-(4-morpholinyl)-8-phenyl-4H-1-benzopyran-4-one; PD98059, 2'-amino-3'-methoxyflavone; SB203580, 4-(4-fluorophenyl)-2-(4-methylsulfinylphenyl)-5-(4-pyridyl)1H-imidazole; FBS, fetal bovine serum; RT-PCR, reverse transcription-polymerase chain reaction; GAPDH, glyceraldehyde-3-phosphate dehydrogenase; p-ERK, phospho-specific extracellular signal-regulated kinase; p-p38, phospho-specific p38 mitogen-activated protein kinase.

2000; Lee et al., 2000; Xu et al., 2001). A G_i-dependent ERK activation is essential for the mitogenic activity of LPA in fibroblasts (Van Corven et al., 1993; Fang et al., 2000). PI3-K/Akt signaling is involved in cell survival in many cellular systems and cancers (Marte and Downward, 1997; Liu et al., 1998; Yuan et al., 2000). The activation of Akt, an antiapoptotic protooncogene, is mediated by PI3-K, after receptor stimulation. PI3-K has also been shown to be the upstream activator of ERK and p38 MAPK (Krump et al., 1997; Lopez-Illasaca et al., 1997). However, the potential interactions between ERK/p38 and Akt activation have just begun to be revealed.

Two different kinases, PDK1 and PDK2, are responsible for the phosphorylation and activation of Akt at T308 and S473, respectively. PDK1 has been cloned and sequenced (Alessi et al., 1997). The mechanism by which S473 undergoes phosphorylation remains obscure. It has been proposed that S473 can be both autophosphorylated and phosphorylated by other kinases, such as PDK1 and integrin-linked kinase-1 (ILK1), which may be promoted by interactions between PDK1 and other kinases associated with Akt (reviewed in Chan and Tschlis, 2001). In vitro phosphorylation of Akt at S473 by MAPK activated protein kinase-2 (MK2), a downstream target of p38, has been reported previously, although it is not involved in the in vivo S473 phosphorylation induced by insulin (Alessi et al., 1996). Recently, Rane et al. (2001) have shown that in neutrophils, p38, but not ERK, activation is required for Akt S473 phosphorylation induced by fMLP, Fc- γ R cross-linking, or phosphatidylinositol-3,4,5-trisphosphate (PIP₃), and MK2 functions as PDK2 to phosphorylate Akt at S473 in vivo (Rane et al., 2001). Apparently, more than one molecular identity may function as PDK2 to phosphorylate Akt at S473, and this may be cell type- or stimulus-dependent.

We describe herein a series of studies examining the signaling mechanisms of LPA- and S1P-induced activation of the PI3-K/Akt pathway in HEY ovarian cancer cells and a panel of other cell lines. In this study, we have focused on the signaling mechanisms of LPA/S1P-induced S473 phosphorylation of Akt in HEY cells, which is essential for the full activation of Akt. We demonstrate here that p38 activation is required for most stimuli (LPA, S1P, PDGF, EGF, thrombin, and Et-1, but not insulin) to induce S473 phosphorylation of Akt in HEY cells. In addition, p38 is required for LPA/S1P-induced S473 phosphorylation of Akt in all 11 responsive cell lines tested. On the other hand, of the stimuli tested, MEK is required for Akt S473 phosphorylation induced only by LPA, S1P, and PDGF, and also occurs in a cell line-specific manner. MEK-dependent Akt phosphorylation occurs in all six ovarian cancer cell lines tested, as well as HeLa cells, and T-47D and MDA-MB-231 breast cancer cells, but not in PC-3 prostate cancer or GI-101A breast cancer cells. Moreover, Akt is phosphorylated in a Rho-dependent manner by LPA but not S1P or PDGF, and Rho acts upstream of PI3-K. Our results show that LPA and S1P decrease paclitaxel-induced caspase-3 activity in HEY cells, which is mediated by the PI3-K/MEK/p38 pathway, suggesting that LPA/S1P-induced Akt activation is potentially involved in survival activities of these cells. Because LPA and S1P probably activate Akt through their Edg receptors, the expression patterns of these receptors in all cell lines used in this study have been examined.

Experimental Procedures

Materials. Oleoyl-LPA and S1P were purchased from Avanti Polar Lipids (Birmingham, AL) or Toronto Research Chemicals (Toronto, ON, Canada). LPA was dissolved in phosphate-buffered saline (PBS), and S1P was dissolved in Tris-saline (50 mM Tris, pH 9.5, 145 mM NaCl) to 4 and 2 mM stock solutions, respectively. LY294002, PD98059, and SB203580 were obtained from Biomol (Plymouth Meeting, PA). Wortmannin and paclitaxel were obtained from Sigma-Aldrich (St. Louis, MO). PTX was purchased from Invitrogen (Rockville, MD). PDGF-BB was a kind gift from the lab of Dr. Paul DiCorleto (Cleveland Clinic Foundation, Cleveland, OH) or was purchased from R & D Systems (Minneapolis, MN). Thrombin and EGF were obtained from Calbiochem (La Jolla, CA) and Et-1 was from Peninsula Laboratories, Inc. (San Carlos, CA). Anti-phospho-S473-Akt, anti-phospho-T308-Akt, anti-Akt, anti-phospho-ERK, anti-ERK, and anti-phospho-p38 antibodies were obtained from Cell Signaling Technology (Beverly, MA). Anti-MEK2, anti-MKK6, and anti-p38 antibodies were from StressGen (Victoria, BC, Canada).

Cell Culture and Transfection. HEY, Ovca420, Ovca429, Ovca432, and Ovca433 ovarian cancer cells were from Dr. G. Mills or Dr. R. Bast, MD Anderson Cancer Center (Houston, TX). MDA-MB-231 and T-47D breast cancer cells were from American Type Culture Collection (Manassas, VA). GI-101A cells were from the Goodwin Institute for Cancer Research, Inc. (Plantation, FL). PC-3 cells were from Dr. Warren Heston (Cleveland Clinic Foundation). All of the above cell lines were maintained in RPMI 1640 medium containing 10% fetal bovine serum (FBS) at 37°C with 5% CO₂. A2780 cells (also from Dr. G. Mills) were maintained in DMEM/Ham's F12 medium (1:1) supplemented with 10% FBS. HeLa cells (from American Type Culture Collection) were maintained in DMEM medium containing 10% FBS. MCF10A immortalized breast cells were obtained from the Karmanos Cancer Institute (Detroit, MI) and cultured as recommended by the provider. All cells were cultured in serum-free media for 24 to 48 h before lipid treatment. For transient transfections, cells were plated into 35-mm dishes and transfected with DNA using LipofectAMINE (Invitrogen) and Transfection Booster Reagents (Gene Therapy Systems, San Diego, CA) according to the manufacturers' instructions. Transfected cells were used within 48 h after transfection. Transfection efficiency was detected by lacZ transfection and β -galactosidase staining. Dominant negative and constitutively active MEK were from Dr. D. Templeton (Case Western Reserve University, Cleveland, OH). Kinase inactive p38 and constitutively active MKK6 were from Dr. Bryan R.G. Williams (Cleveland Clinic Foundation). Dominant-negative and constitutively active Rho were from Dr. Wouter Moolenaar, (Netherlands Cancer Institute, Amsterdam, The Netherlands). The C3-exoenzyme construct and constitutively active PI3-K (p110- α isoform) were provided by Dr. Alan Wolfman (Cleveland Clinic Foundation).

Nonradioactive Immunoprecipitation Akt Kinase Assay. The Akt kinase assay was performed with the Nonradioactive Akt Kinase Assay Kit (Cell Signaling Technology) according to the manufacturer's instructions. All reagents were provided with the kit. Briefly, cells were treated with LPA or S1P, rinsed with ice-cold PBS, and then lysed in cell lysis buffer. Immunoprecipitation was carried out using immobilized Akt 1G1 monoclonal antibody. The immunoprecipitate was then incubated with GSK-3 fusion protein and ATP in kinase buffer. Western analyses were used to determine the extent of GSK-3 phosphorylation by active Akt using a phospho-GSK-3 α/β (Ser21/9) antibody.

Western Blot Analysis. After treatment with LPA, S1P, or other stimuli, cells were rinsed with ice-cold PBS, and then lysed in SDS sample buffer. Samples were electrophoresed through 10 to 12% SDS polyacrylamide gels and then transferred to PVDF membranes (Bio-Rad, Hercules, CA). Immunoblot analyses were carried out using the appropriate antibodies. Specific proteins were detected with the enhanced chemiluminescence system (Amersham Biosciences, Piscataway, NJ).

Quantitative RT-PCR of LPA/S1P Receptor Expression. Total RNA was extracted from cells using the SV Total RNA Isolation System (Promega, Madison, WI). Total RNA (1–5 μ g) was reverse transcribed using Superscript II RT (Invitrogen). Derived cDNA (8 ng) was used as a template for real-time quantitative SYBR Green I PCR. Primer sequences for S1P₁ (Edg-1), S1P₂ (Edg-5), S1P₃ (Edg-3), LPA₁ (Edg-2), and LPA₂ (Edg-4) were kindly provided by Dr. Ed Goetzl (UCSF) and are as follows: S1P₁, 5'GCAGCAGCAAGATGC-GAAG and 5'CGATGAGTGATCCAGGCTTTT; S1P₂, 5'GCGCCAT-TGTGGTGGAA and 5'GAGCCAGAGCAAGGTATTGG; S1P₃, 5'CTGGTGACCATCGTGATCCTC and 5'ACGCTCACCACAAT-CACCAC; LPA₁, 5'GCTGGTGTGGGACTTGGAAAT and 5'CAAC-CCAGCAAAGAAGTCTGC; and LPA₂, 5'ACGCTCAGCCTGGTCAA-GAC and 5'AACCATCCAGGAGCAGTACCAC. Primer sequences for S1P₅ (Edg-8) and LPA₃ (Edg-7) were developed in our lab and are: S1P₅, 5'CGCCTTCATCGTGCTAGAGA and 5'AGATCCGA-CAACGTGAGGCT; and LPA₃, 5'TCCAACCTCATGGCCTTCC and 5'GACCCACTTGTATGCGGAGAC. GAPDH was amplified in a separate tube as a housekeeping gene with primers 5'GAAGGTGAAG-GTCGGAGT and 5'GAAGATGGTATGGGATTTC. All SYBR Green I core reagents, including AmpliTaq Gold polymerase, were from Applied Biosystems (Foster City, CA). The thermal cycling conditions were 95°C for 10 min, followed by 40 cycles of 95°C for 15 s and 60°C, 1 min. PCR reactions and product detection were carried out in an ABI Prism 7700 Sequence Detection System (Applied Biosystems). Amplified product was detected by measurement of the fluorescent dye, SYBR Green I, which was added to the initial reaction mixture and binds proportionally to double-stranded DNA. After completion of the PCR, a fixed threshold (DNA amount reflected by bound fluorescent dye) was selected based on the manufacturer's suggestion, and the number of cycles (the threshold cycle, or C_T) required to amplify the target to reach this threshold was used for calculations. The comparative C_T method (User Bulletin #2; Applied Biosystems) was used to determine relative amounts of each receptor. The comparative C_T method is similar to the standard curve method, except that it uses arithmetic formulas derived by Applied Biosystems to achieve the same results for relative quantitation. For this method to be valid, the efficiencies of the target (i.e., LPA/S1P receptor) and reference (i.e., GAPDH) must be approximately equal. We have validated the amplification efficiencies of each of our targets to meet this requirement.

Measurement of Caspase-3 Activity. Cells were seeded into 96-well plates, grown to 80% confluence, and then cultured overnight in serum-free media. The following day, cells were pretreated with or without various reagents, followed by exposure to paclitaxel for the indicated periods of time. Cells were then washed with PBS and lysed in caspase-3 assay kit cell lysis buffer (Calbiochem). Caspase-3 activity was measured by cleavage of the fluorogenic substrate *N*-acetyl-Asp-Glu-Val-Asp-amino-4-methylcoumarin with the Caspase-3 Assay Kit (Calbiochem).

Results

LPA and S1P Induced Akt Activation in HEY Ovarian Cancer Cells in a PI3-K-, MEK-, and p38-Dependent Manner. LPA and S1P are present in ovarian cancer ascites and are likely to be involved in proliferation and survival of ovarian tumor cells. We have shown that LPA and S1P stimulate ovarian cancer cell proliferation (Xu et al., 1995a; Hong et al., 1999). However, the effects and mechanisms of LPA/S1P-induced PI3-K/Akt activation in ovarian cancer cells have not previously been reported. To investigate the effects of LPA and S1P on Akt activation in HEY ovarian cancer cells, we treated these cells with physiological concentrations of LPA and S1P, and then measured the activity of Akt with an Akt kinase assay. LPA (10 μ M) and S1P (1 μ M)

induced activation of Akt compared with the untreated control (Fig. 1). To determine the mechanism of LPA/S1P-induced Akt activation, and in particular, to test whether there is an interaction between a major cell proliferation signaling pathway (MEK/ERK) and a major cell survival pathway (PI3-K/Akt), we examined the sensitivity of Akt activation induced by LPA and S1P to three specific inhibitors of PI3-K, MEK, and p38 MAPK: LY294002, PD98059, and SB203580, respectively. Pretreatment of HEY cells with all three of these inhibitors abolished activation of Akt by LPA and S1P (Fig. 1), suggesting a dependence on PI3-K, MEK, and p38 for LPA/S1P-induced Akt activation.

Time- and Concentration-Dependent Akt S473 Phosphorylation Induced by LPA and S1P. Akt activation is mediated through phosphorylation of S473 and T308. Western blot analyses with Akt-S473-phospho-specific antibodies were used to measure LPA/S1P-induced S473 phosphorylation of Akt. LPA and S1P induced a time-dependent Akt S473 phosphorylation in HEY cells (Fig. 2, A and B). HEY cells displayed a low basal level of Akt S473 phosphorylation, which was not increased over the time course (Fig. 2A). Both LPA and S1P induced a time- and concentration-dependent S473 phosphorylation of Akt, occurring as early as 5 min, with maximal stimulations of Akt S473 phosphorylation occurring at 20 min (Fig. 2B) and at 10 μ M for LPA and 1 μ M for S1P (Fig. 2C). Our results demonstrate that at concentrations of LPA greater than 10 μ M, the Akt and ERK phosphorylation levels are significantly decreased compared with 10 μ M LPA (Fig. 2C and data not shown). Furthermore, there is a correlation between the fold-change decrease in phosphorylation of Akt and ERK (with LPA concentrations greater than 10 μ M). LPA and S1P had relatively narrow optimal concentration ranges for Akt activation. We observed a similar phenomenon in LPA-induced thymidine incorporation (Xu et al., 1995b). The relationship between these effects is currently under investigation.

PI3-K and G_i-Dependent T308 and S473 Akt Phosphorylation by LPA and S1P. Because phosphorylation of both T308 and S473 are necessary for the complete activation of Akt, we examined the ability of LPA and S1P to stimulate Akt T308 phosphorylation. Both LPA and S1P were able to induce an approximately 4- to 6-fold increase in Akt phosphorylation at T308 in HEY cells (Fig. 3). To determine whether S473 and T308 phosphorylation of Akt by LPA and S1P were dependent on PI3-K activity, we examined the effect of the specific PI3-K inhibitor, LY294002, on Akt phosphorylation. LPA- and S1P-induced S473 and T308 phosphorylation of Akt were completely abolished by pretreatment of cells with LY294002 (10 μ M) (Fig. 3). The dependence on PI3-K was further confirmed by pretreatment

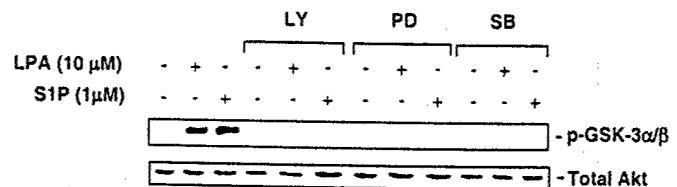

Fig. 1. LPA and S1P activate Akt in a PI3-K-, MEK-, and p38-dependent manner. Nonradioactive immunoprecipitation Akt kinase assay of HEY cells pretreated with or without 10 μ M LY294002 (LY), 30 μ M PD98059 (PD), or 10 μ M SB203580 (SB) for 30 min, and then treated with LPA (10 μ M) or S1P (1 μ M) for 20 min.

with wortmannin (150 nM), a second, structurally different, specific inhibitor of PI3-K (Fig. 3).

LPA and S1P elicit many of their cellular effects by binding to their cell membrane GPCRs and subsequently activating G proteins (Goetzl and An, 1998; Moolenaar, 1999; Spiegel, 1999). To determine which G protein was potentially involved in LPA- and S1P-induced S473 and T308 phosphorylation of Akt, we treated cells with PTX (100 ng/ml) for 16 h before treatment with lipids. Western analyses showed that PTX pretreatment resulted in inhibition of approximately 60% of LPA- and 80% of S1P-induced Akt S473 and complete inhibition of T308 phosphorylation (Fig. 3), indicating that both of these lipids activate Akt mainly via $G_{\beta\gamma}$ -dependent signaling pathway(s).

LPA- and S1P-Induced Akt S473 and T308 Phosphorylation Are Dependent on MEK, but Only S473 Phosphorylation Is p38-Dependent, and MEK Is Upstream

of p38. Phosphorylation of both S473 and T308 is essential for the full activation of Akt. However, Akt S473 and T308 may be phosphorylated through different mechanisms. Because LPA/S1P-induced Akt enzymatic activation was MEK- and p38-dependent (Fig. 1), we determined whether phosphorylation of Akt S473 and T308 by LPA/S1P also were MEK- and p38-dependent. We used PD98059 and SB203580 as specific inhibitors of MEK (the upstream kinase of ERK) and p38, respectively. To use the optimal concentration of these inhibitors, we performed titration analyses and observed that PD98059 at 3, 10, and 30 μ M had an inhibitory effect on LPA/S1P-induced ERK and Akt phosphorylation of approximately 60, 90, and 100%, respectively. Similarly, SB203580 at 1, 3, and 10 μ M had an inhibitory effect on LPA/S1P-induced p38 and Akt phosphorylation of approximately 60, 90, and 100%, respectively. PD98059 (30 μ M) completely inhibited Akt S473 and T308 phosphorylation

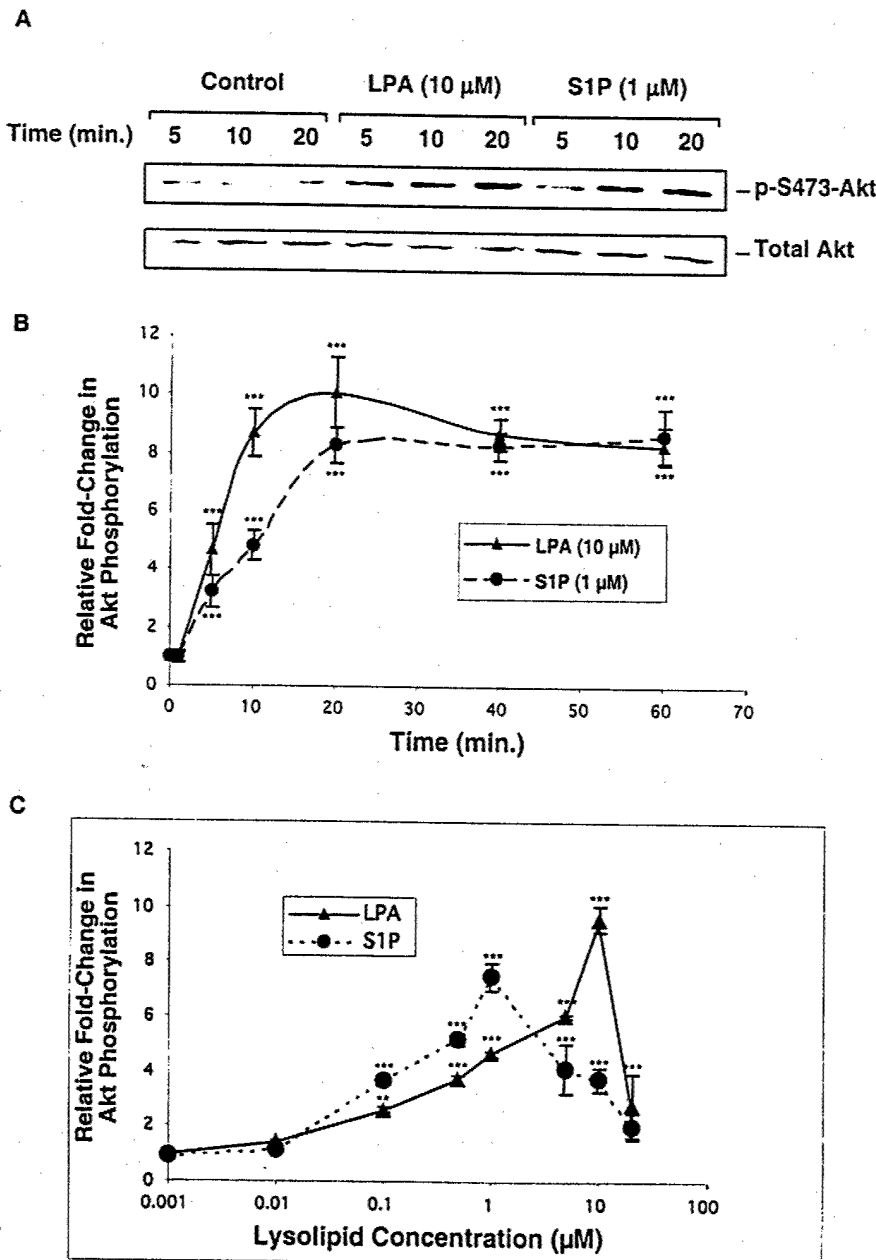

Fig. 2. Time- and concentration-dependent S473 phosphorylation of Akt by LPA and S1P. Western analyses of HEY cell lysates probed with phospho-specific Akt S473 (p-S473-Akt) or Akt (total Akt) antibodies. **A**, cells were treated without lipid (Control) or with LPA (10 μ M) or S1P (1 μ M) for 5, 10, and 20 min. The Western analysis shown is a representative example of at least three independent experiments. **B**, cells were treated with LPA (10 μ M) or S1P (1 μ M) for various time points as indicated, up to 60 min. Results were plotted as the mean \pm S.D. of three independent experiments. Fold-change in Akt phosphorylation is normalized to the levels of total Akt. **C**, cells were treated with LPA and S1P for 20 min at the indicated dosages. Results were plotted as the mean \pm S.D. of three independent experiments. Fold change in Akt phosphorylation is normalized to the levels of total Akt. ***, $p < 0.001$; **, $p < 0.01$ (Student's t -test).

induced by LPA and S1P (Fig. 4A, 1 and 2), suggesting that MEK, and potentially its downstream target, ERK, was involved in phosphorylation of Akt at both S473 and T308. Interestingly, we found that although SB203580 (10 μ M) completely abolished Akt S473 phosphorylation induced by both LPA and S1P (Fig. 4A, 1), T308 phosphorylation was not altered by pretreatment with up to 30 μ M SB203580 (Fig. 4A, 2). These results suggest that p38 activation is required for LPA/S1P-induced Akt S473, but not T308, phosphorylation.

To confirm the effects of PD98059 and SB203580 on their targets, we used Western analyses with antibodies against phosphorylated ERK (ERK is the downstream target of MEK) and phosphorylated p38. Our results show that LPA and S1P activated ERK and p38 in HEY cells (Fig. 4A, 4 and 5) with an optimal time of ERK and p38 activation by LPA/S1P at 5 and 10 min, respectively, that was sustained for 60 min (data not shown). The ERK activation induced by LPA and S1P was abrogated (>90%) by pretreatment with PD98059 but not SB203580, although a general inhibition (<20%) of phosphorylated ERK by SB203580 in control and in LPA- and S1P-treated cells was observed (Fig. 4A, 4). p38 activation, on the other hand, was completely inhibited by pretreatment with both PD98059 and SB203580 (Fig. 4A, 5). These results show that MEK, and probably ERK, activity was required for both Akt S473 and T308 phosphorylation. In contrast, p38 activity was required for phosphorylation of Akt at S473 but not T308. In addition, MEK and ERK were likely to be upstream of p38 in activating Akt S473 phosphorylation. The activation of ERK alone, when p38 activation was blocked (i.e., in the presence of the p38 inhibitor, SB203580), was not sufficient to induce S473 phosphorylation of Akt (Fig. 4A, 1 and 4).

Although these inhibitors (PD98059 and SB203580) exhibit high specificity for their targets, it has been shown that at relatively high concentrations, these inhibitors may also inhibit other molecular targets. Thus, to further confirm that Akt S473 phosphorylation by LPA and S1P was dependent on MEK and p38 MAPKs, and that MEK was upstream of p38, we transiently transfected HEY cells with dominant-negative MEK (MEK/2A) and kinase-inactive p38 (p38/AGF). Although HEY cells are relatively difficult to transfect, we consistently obtained transfection efficiencies of greater than 70%, as analyzed by lacZ transfection and β -galactosidase staining, when we used the Transfection Booster Reagents (Transfection Booster #3; *Experimental Procedures*). The

overexpression of genetically altered MEK or p38 was evidenced by Western blot analysis (Fig. 4B, 7 and 8). Consistent with the results induced by pharmacological inhibitors (Fig. 4A, 1 and 2), Akt S473 and T308 phosphorylation induced by LPA and S1P was inhibited ~70 to 80% by MEK/2A (Fig. 4B, 1 and 2). Transfection with p38/AGF resulted in decreased Akt S473 but not T308 phosphorylation (Fig. 4B, 1 and 2). In addition, transfection with MEK/2A resulted in decreased ERK and p38 activation, whereas transfection with p38/AGF inhibited only p38 (~80%), not ERK (<15%), phosphorylation (Fig. 4B, 4 and 5). These results confirmed the data obtained from pharmacological inhibitors and indicate that 1) activation of both MEK and p38 MAPK are necessary for the S473 phosphorylation of Akt; 2) activation of MEK, but not p38 MAPK, is necessary for the T308 phosphorylation of Akt; 3) MEK acted upstream of p38; and 4) ERK activation, in the presence of kinase inactive p38, was not sufficient to activate Akt in HEY cells. Therefore, these data suggest that the action of MEK was mediated through p38 to ultimately lead to Akt S473 phosphorylation induced by LPA and S1P in HEY cells.

To determine whether activated MEK and/or MKK6 (an upstream activator of p38) were sufficient to phosphorylate Akt at S473 and/or T308, we transfected HEY cells with constitutively active MEK (MEK/2E) and MKK6 (MKK6/2E). Interestingly, although both MEK/2E and MKK6/2E were sufficient to induce phosphorylation of Akt at S473, neither could stimulate T308 phosphorylation in the absence of stimuli (Fig. 4C, 1 and 2). These data indicate that MEK is both necessary and sufficient for S473 phosphorylation and necessary but insufficient for T308 phosphorylation of Akt.

Because our data indicated that MEK acted upstream of p38, we examined whether the activation of MEK was sufficient to activate p38 and whether MKK6 had any effect on p38 and ERK activation. Results show that in addition to Akt, MEK/2E was also sufficient for ERK and p38 activation (Fig. 4C, 4 and 5). On the other hand, MKK6/2E activated p38 (Fig. 4C, 5), but did not affect either the basal level or LPA/S1P-induced ERK phosphorylation (Fig. 4C, 4). Whereas the potency of p38 activation by MEK/2E was similar to the levels induced by LPA and S1P, it was lower than that induced by MKK6/2E (compare lanes 4–6 with lanes 7–9 in Fig. 4C, 5). These results further confirmed that MEK was upstream of p38 and MEK was capable of activating p38 in HEY cells, although not as strongly as constitutively active MKK6.

We have shown that Akt S473 and T308 phosphorylation induced by LPA and S1P were dependent on both G_i and PI3-K (Fig. 3). To determine whether ERK and p38 were downstream of G_i and PI3-K, we tested the effects of PTX and LY294002 on LPA- and S1P-induced ERK and p38 activation. Inhibition of G_i or PI3-K with PTX or LY294002, respectively, inhibited LPA- and S1P-induced activation of ERK and p38 (Fig. 4D), suggesting that both G_i and PI3-K are upstream of ERK and p38. PI3-K-dependent ERK/p38 activation was further confirmed by overexpression of constitutively active PI3-K, which was sufficient for activation of ERK and p38 in HEY cells (Fig. 4E). Furthermore, treatment with both PD98059 and SB203580 could inhibit induction of phosphorylated Akt by constitutively active PI3-K (Fig. 4F), indicating that PI3-K is dependent on MEK and p38 for Akt S473 phosphorylation. This was confirmed by overexpression

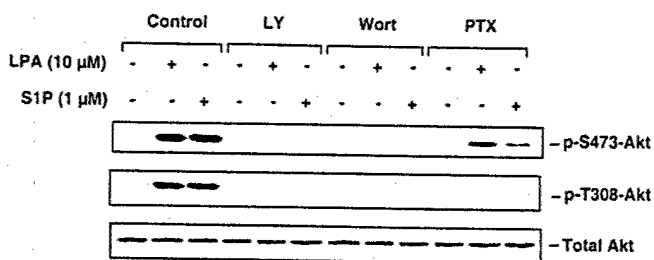

Fig. 3. PI3-K- and G_i -dependent Akt S473 and T308 phosphorylation by LPA and S1P. HEY cells were pretreated with 10 μ M LY294002 (LY) or 150 nM wortmannin (Wort) for 30 min, or 100 ng/ml PTX for 16 h before treatment with LPA (10 μ M) or S1P (1 μ M) for 20 min. Cell lysates were collected and analyzed for S473 and T308 phosphorylation of Akt, as well as total Akt, by Western blotting. The Western analysis shown is a representative example of at least three independent experiments.

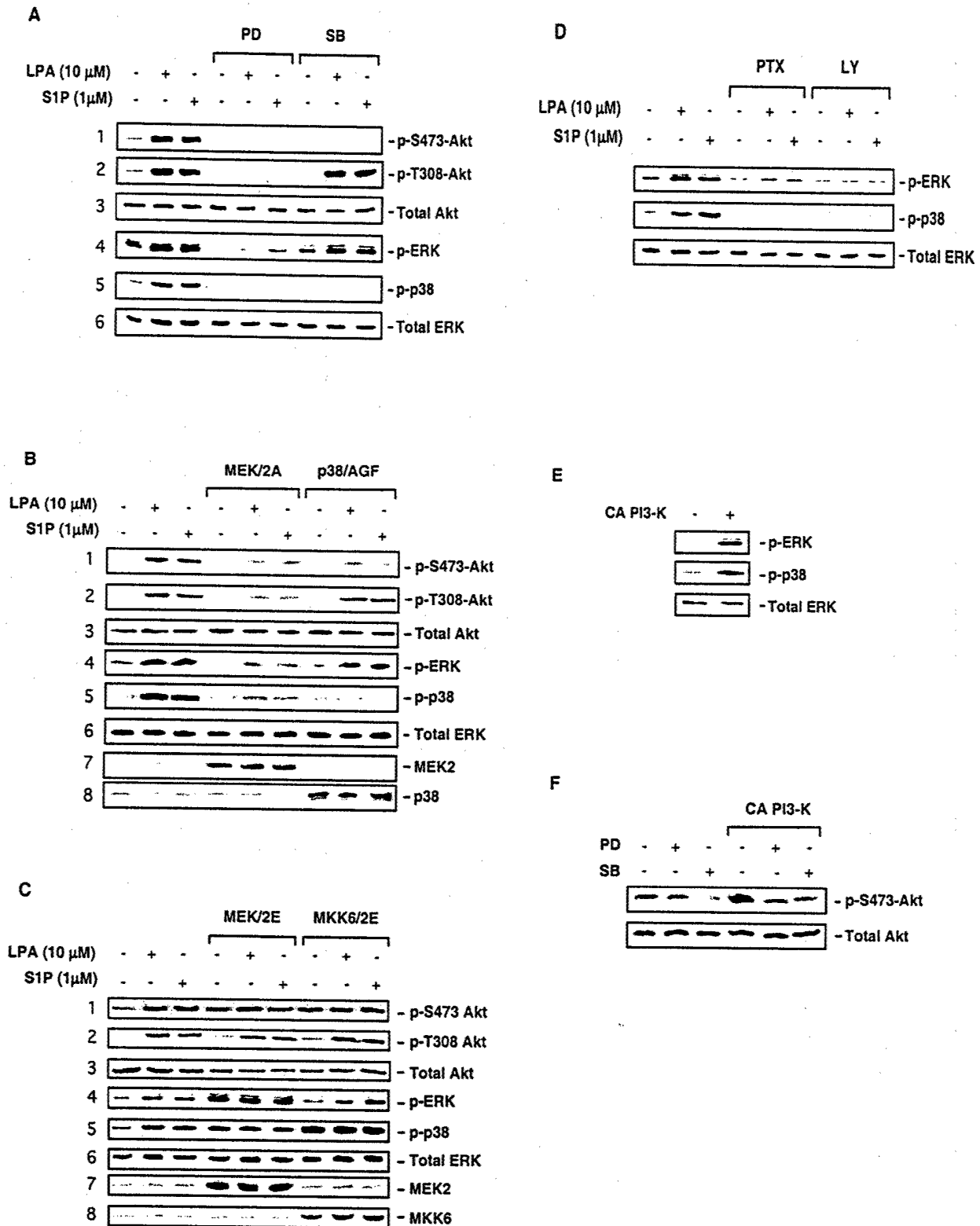

Fig. 4. MEK- and p38 MAPK-dependent Akt S473 phosphorylation and MEK-dependent Akt T308 phosphorylation by LPA and S1P. Western analyses of HEY cell lysates probed with p-S473-Akt, p-T308-Akt, phospho-specific ERK (p-ERK), total ERK antibodies. **A**, HEY cells were pretreated with 30 μ M PD98059 (PD) or 10 μ M SB203580 (SB) for 30 min followed by treatment with LPA (10 μ M) or S1P (1 μ M) for 10 min (p-ERK, p-p38) or 20 min (p-Akt). **B**, HEY cells were transiently transfected with control vector, dominant-negative MEK (MEK/2A), or kinase inactive p38 MAPK (p38/AGF), and then treated with LPA (10 μ M) or S1P (1 μ M) for 10 min (p-ERK, p-p38) or 20 min (p-Akt). **C**, HEY cells were transiently transfected with control vector, constitutively active MEK (MEK/2E), or constitutively active MKK6 (MKK6/2E) and then treated with LPA (10 μ M) or S1P (1 μ M) for 10 min (p-ERK, p-p38) or 20 min (p-Akt). **D**, HEY cells were pretreated with 100 ng/ml PTX or 10 μ M LY294002 (LY) for 16 h or 30 min, respectively, followed by treatment with LPA (10 μ M) or S1P (1 μ M) for 10 min. **E**, HEY cells were transiently transfected with constitutively active PI3-K (CA PI3-K). **F**, HEY cells overexpressing CA PI3-K or vector control were treated with 30 μ M PD98059 (PD) or 10 μ M SB203580 (SB) for 30 min. Each Western analysis shown is a representative example of at least three independent experiments.

of genetic inhibitors (MEK/2A and p38/AGF), which also resulted in a decrease in Akt phosphorylation by constitutively active PI3-K (data not shown).

MEK-Dependent Akt S473 Phosphorylation Is Specific to LPA, S1P, and PDGF, but Not Thrombin, EGF, Et-1, or Insulin. The kinase activity of Akt was $\geq 90\%$ inhibited by SB203580 (Fig. 1) and the phosphorylation of Akt S473, but not T308, was sensitive to both SB203580 and transfection with MEK/2A, suggesting that S473 phosphorylation was essential for the majority of the Akt kinase activity in this system. Therefore, we focused the rest of our studies on the mechanisms of Akt S473 phosphorylation induced by LPA and S1P. Akt can be activated by a variety of growth factors through their receptors, as well as via a number of GPCR ligands. We sought to determine whether MEK-dependent S473 phosphorylation of Akt in HEY cells was specific to LPA and S1P. Treatment of HEY cells with PDGF (10 ng/ml), thrombin (1 U/ml), EGF (10 ng/ml), Et-1 (100 nM), or insulin (100 nM) for 5 min induced S473 phosphorylation of Akt (Fig. 5A). The phosphorylation of Akt by all five of these stimuli was PI3-K-dependent as evidenced by pretreatment with LY294002 (data not shown). Pretreatment of cells with SB203580 (3–10 μ M) resulted in inhibition of Akt S473 phosphorylation induced by PDGF, EGF, thrombin, and Et-1, but not insulin, indicating that p38 activation is required by most stimuli tested (Fig. 5A). In contrast, of these factors tested, only PDGF required activation of MEK for S473 phosphorylation of Akt as evidenced by the sensitivity of this activation to pretreatment with PD98059 (Fig. 5A), suggesting that MEK-dependent Akt S473 phosphorylation is stimulus-specific. This was further supported by transient transfection with MEK/2A, which resulted in decreased Akt S473 phosphorylation by PDGF but not Et-1, even though the latter also activated ERK, which was sensitive to the dominant inhibitory effect of MEK/2A (Fig. 5B).

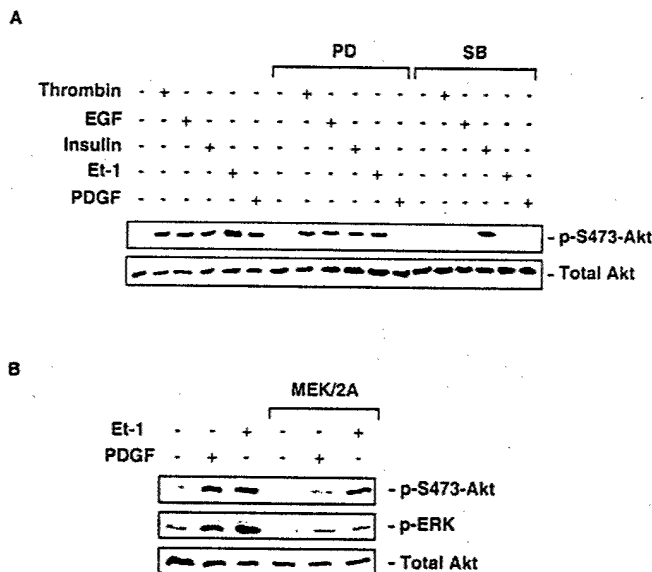

Fig. 5. Stimulus-specific S473 phosphorylation of Akt. Western analyses of HEY cell lysates probed with p-S473-Akt, and then reprobred with p-ERK or total Akt antibodies. A, cells were pretreated with 30 μ M PD98059 (PD) or 10 μ M SB203580 (SB) for 30 min followed by treatment with thrombin (1 U/ml), EGF (10 ng/ml), insulin (100 nM), Et-1 (100 nM), or PDGF-BB (10 ng/ml) for 5 min. B, cells transiently transfected with MEK/2A were treated with Et-1 (100 nM) or PDGF-BB (10 ng/ml) for 5 min.

LPA, but Not S1P or PDGF, Requires Rho for S473 Phosphorylation of Akt, and Rho Is Upstream of PI3-K.

To test the potential involvement of Rho in Akt S473 phosphorylation induced by LPA, S1P, and PDGF, we transiently transfected HEY cells with dominant negative Rho (Rho/N19) or C3-exoenzyme. Interestingly, overexpression of Rho/N19 or C3-exoenzyme resulted in decreased Akt S473 phosphorylation by LPA, but not S1P (Fig. 6A, 1). Furthermore, LPA, but not S1P, required Rho for phosphorylation of ERK and p38 (Fig. 6A, 3 and 4). Similar to S1P, overexpression of Rho/N19 did not inhibit PDGF-induced Akt S473 phosphorylation (Fig. 6B). Transfection with constitutively active Rho (Rho/V14) demonstrated that Rho was sufficient for S473 phosphorylation of Akt in HEY cells (Fig. 6C, 3rd column).

To determine whether Rho acted upstream or downstream of PI3-K, HEY cells transfected with Rho/V14 were treated with LY294002. This treatment resulted in abolishment of S473 phosphorylation of Akt by Rho/V14 (Fig. 6C), suggesting that Rho is upstream of PI3K. This was further confirmed

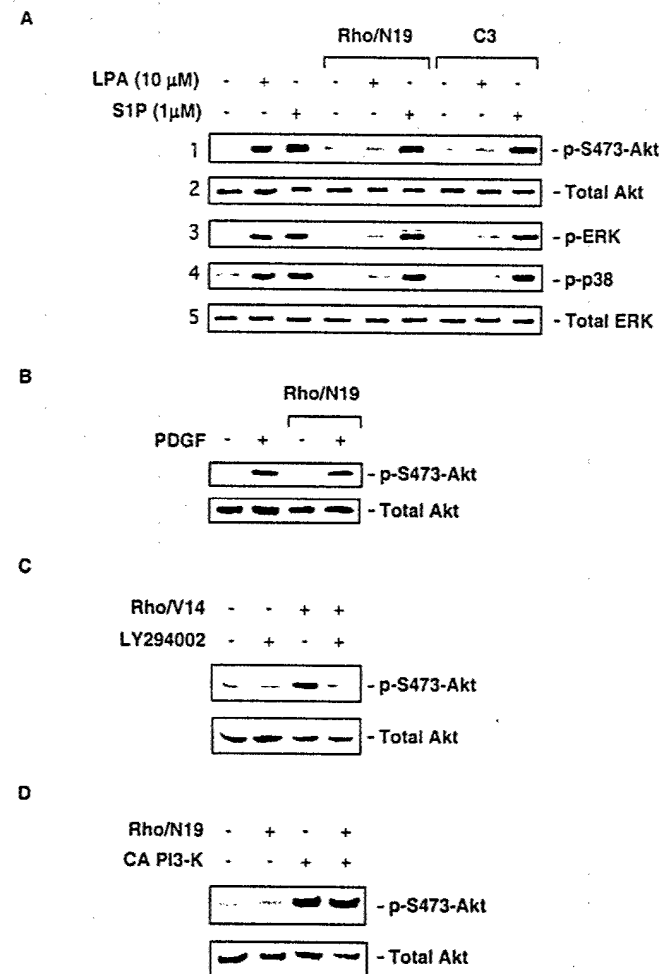

Fig. 6. Rho-dependent S473 phosphorylation of Akt by LPA but not S1P or PDGF. Western analyses of HEY cell lysates probed with p-S473-Akt, p-ERK, p-p38, total Akt, or total ERK antibodies. Cells were transiently transfected with control vector, dominant-negative Rho (Rho/N19), or C3-exoenzyme (C3) (A, B), constitutively active Rho (Rho/V14) (C), or Rho/N19 and/or constitutively active PI3-K (CA PI3-K) (D). A, transfected cells were treated with LPA (10 μ M) or S1P (1 μ M) for 10 min (p-ERK, p-p38) or 20 min (p-Akt). B, transfected cells were treated with PDGF (10 ng/ml) for 10 min. C, transfected cells were treated with LY294002 (10 μ M) for 30 min after transfection.

by co-transfection of Rho/N19 and constitutively active PI3-K, in which Rho/N19 had no effect on the increased Akt S473 phosphorylation by constitutively active PI3-K (Fig. 6D).

MEK/ERK-Dependent Akt S473 Phosphorylation Is Cell Line-Specific. In contrast to what we have observed in HEY cells with LPA and S1P, the S473 phosphorylation of Akt induced by fMLP, Fc- γ R cross-linking, or PIP₃ in human neutrophils was insensitive to pretreatment with PD98059 (Rane et al., 2001). To determine whether this MEK-dependent S473 phosphorylation of Akt by LPA and S1P was cell-type-specific, we tested five other ovarian cancer cell lines (Ovca420, Ovca429, Ovca432, Ovca433, A2780), three breast cancer cell lines (MDA-MB-231, T-47D, and GI-101A), and HeLa (cervical cancer), PC-3 (prostate cancer), and MCF10A (immortalized breast epithelial) cells. In all cell lines tested, except the immortalized breast MCF10A cell line (Fig. 7C), LPA and S1P induced a 1.7- to 10.1-fold increase in Akt S473 phosphorylation (Table 1). Whereas MCF10A cells were the only cells in this study that did not respond to LPA/S1P for Akt phosphorylation, we have ob-

served that LPA and S1P can induce Akt activity in other noncancerous cell lines (specifically, Swiss 3T3 cells or mouse embryonic fibroblasts; unpublished observations). Thus, a simple, generalized conclusion pertaining to the effects of LPA and S1P on Akt induction in cancerous versus noncancerous cells cannot be drawn through our limited studies.

Interestingly, we observed that Akt S473 phosphorylation induced by LPA and S1P in all five ovarian cancer cell lines, in addition to HEY cells, was sensitive to pretreatment with both PD98059 and SB203580 (3–10 μ M; \geq 72% inhibition; Table 1). In addition, HeLa and T-47D cells were also sensitive to pretreatment with both inhibitors. Among the remaining cell lines, MCF10A cells were nonresponsive to LPA and S1P (Fig. 7C), MDA-MB-231 cells were partially sensitive to both inhibitors and PC-3 and GI-101A cells were sensitive to only SB203580. These experiments have been repeated more than three times in each cell line and the results (average \pm SD) are presented in Table 1. This data suggests that although p38 was required for LPA/S1P-induced S473 phosphorylation of Akt in all 11 responsive cell lines tested, the MEK-dependent Akt phosphorylation induced by LPA and S1P is specific to certain cell lines.

We tested the PD98059-insensitive cell lines to demonstrate that LPA and S1P could activate ERK in these cell lines, and the concentration of PD98059 used blocked ERK activation in these cells (Fig. 7, A and B, and other data not shown). Therefore, the insensitivity of LPA/S1P-induced Akt phosphorylation to PD98059 was not due to either the inability of LPA/S1P to induce ERK activation or a variation in cell line sensitivity to PD98059. The results from Ovca420 (Fig. 7A) and GI-101A (Fig. 7B) are shown as representative results from cells that were PD98059-sensitive and -insensitive in LPA/S1P-induced Akt S473 phosphorylation, respectively. In both of these cell lines, LPA and S1P induced ERK activation, which was blocked by PD98059 but not by SB203580 (Fig. 7, A and B, middle).

The LPA/S1P Receptors Potentially Involved in Mediating the S473 Phosphorylation of Akt. Three [LPA₁ (Edg-2), LPA₂ (Edg-4), and LPA₃ (Edg-7)] and five [S1P₁ (Edg-1), S1P₂ (Edg-5), S1P₃ (Edg-3), S1P₄ (Edg-6), and S1P₅ (Edg-8)] GPCRs have been identified as receptors for LPA and S1P, respectively. To determine which of these receptors might be associated with the MEK-dependent Akt activation in different cell lines, we examined the expression of S1P₁₋₃, S1P₅, and LPA₁₋₃ in all cell lines used in this study with quantitative real time RT-PCR (Table 2). Because S1P₄ is predominantly expressed in lymphocytes (Graler et al., 1998; Van Brocklyn et al., 2000), and all of our cell lines are of epithelial origin, the expression of this receptor was not determined in our studies. The comparative threshold cycle (C_T) method (*Experimental Procedures*) was used to calculate the relative expression of each receptor in different cell lines. We arbitrarily chose the expression level of LPA₂ in HEY cells (relative to GAPDH in these cells) as 1-fold. The expression levels of all other receptors in HEY and all other cell lines (relative to GAPDH in the corresponding cell lines) are expressed as fold-change relative to this 1-fold expression of HEY LPA₂ (Table 2). The LPA/S1P receptor expression levels in HEY cells obtained through our studies are consistent in principle with the levels reported by Fischer et al. (2001), using a semiquantitative RT-PCR method (Fischer et al., 2001). In our studies, we considered 1-fold expression to be

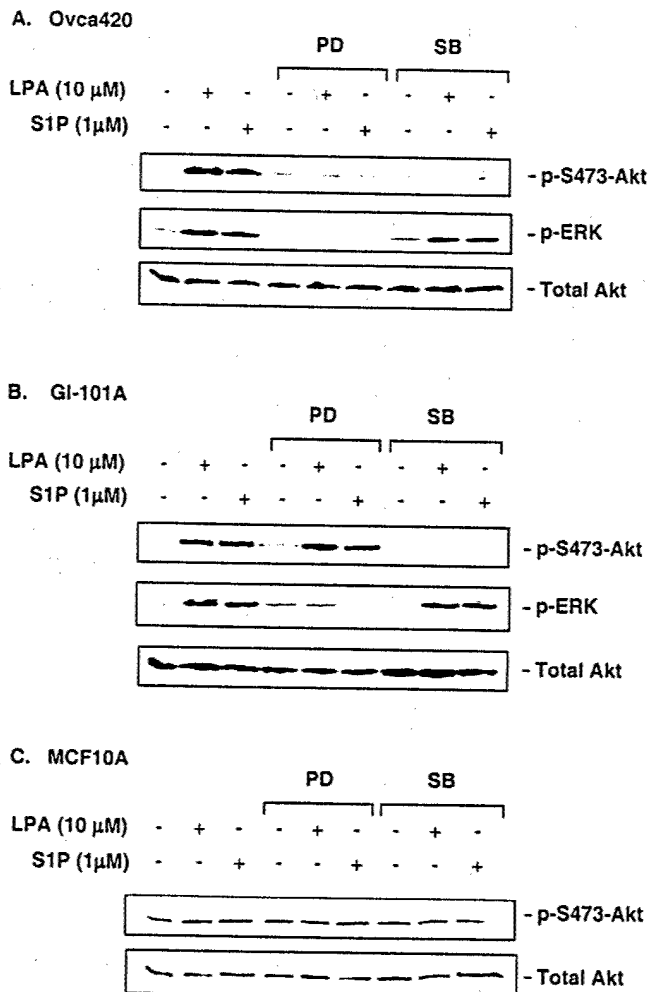

Fig. 7. The effect of LPA/S1P on Akt S473 phosphorylation in Ovca420, GI-101A, and MCF10A cells. Western analyses of cell lysates probed with p-S473-Akt, and then reprobbed with p-ERK or total Akt antibodies. Cells were pretreated with 30 μ M PD98059 (PD) or 10 μ M SB203580 (SB) for 30 min followed by treatment with LPA (10 μ M) or S1P (1 μ M) for 20 min. A, Ovca420 cells; B, GI-101A cells; C, MCF10A cells.

low, because LPA₂ was previously detected at a very low level in HEY cells using a semiquantitative RT-PCR method (Fischer et al., 2001). Thus, when the fold expression of the receptor was below 1.0 in our studies, we considered it to be very low or not expressed.

All cell lines tested expressed at least one S1P and one LPA receptor (Table 2). For the S1P receptors, S1P₁ was expressed in a number of cell lines, such as HEY, Ovca429, and Ovca433, but it had a lower or no expression in both MEK-dependent and -independent cell lines, such as A2780, HeLa, T-47D, GI-101A, and PC-3. S1P₂ was expressed in the entire set of cell lines used in this study but had a relatively lower expression in HEY cells. S1P₅ had very low or no expression in all of the cell lines, except Ovca420 and T-47D. Therefore, S1P₁, S1P₂, and S1P₅ are unlikely to be the determining receptor or the only determining factors for the MEK-dependence of S1P in these cell lines. Interestingly, S1P₃ was expressed in all of the cell lines used in these studies except GI-101A and PC-3, which were MEK-independent. Whether this was a simple correlation among the cell lines tested, or whether S1P₃ represents a real molecular determinant for MEK-dependent Akt activation by S1P requires further investigation.

For the LPA receptors (LPA₁₋₃), LPA₁ was expressed in most of the cell lines except HeLa, GI-101A, and MCF-10A (Table 2). All cell lines tested expressed LPA₂, although the expression level of LPA₂ was low in HEY cells. Most cell lines expressed LPA₃, except Ovca420 and T-47D. Furthermore, the level of expression of LPA₃ was relatively lower in MCF-10A cells. Apparently, a simple correlation between the expression pattern of LPA receptors and the MEK-dependent Akt activation induced by LPA could not be made, suggesting that factors other than receptors for LPA may play a critical role in determining the signaling pathways leading to Akt activation.

Caspase-3 Activity Induced by Paclitaxel in Hey Cells Was Inhibited by LPA and S1P. Akt has been described as a mediator of survival signals in many cell types (Marte and Downward, 1997), including ovarian cancer cells (Liu et al, 1998; Yuan et al., 2000). Furthermore, LPA has been shown to prevent HEY cell death induced by *cis*-diaminedichloroplatinum (Frankel and Mills, 1996). Because

paclitaxel is a potent apoptotic inducer in many ovarian cancer cell lines, we investigated the potential for LPA and S1P to prevent paclitaxel-induced apoptosis in HEY cells and whether the effect was related to the PI3-K signaling pathway. We used a caspase-3 activity assay as a sensitive measurement of the effect of paclitaxel on HEY cells. Caspase-3 activity was measured in HEY cells treated for various times and concentrations of paclitaxel, and it was determined that optimal caspase-3 activity occurred after 24 h treatment with 1 μ M paclitaxel (data not shown). Pretreatment of cells for 20 min with LPA (10 μ M) and S1P (1 μ M) inhibited ($\geq 45\%$) caspase-3 activity induced by paclitaxel (Fig. 8). Pretreatment with LY294002, PD98059, and SB203580, followed by treatment with LPA and S1P, and then paclitaxel, reinstated caspase-3 activity (Fig. 8). These results suggest that the PI3-K/MEK/p38 signaling pathway mediates LPA/S1P-induced inhibition of caspase-3 activity, which is the same signaling pathway leading to LPA/S1P-stimulated Akt S473 phosphorylation in HEY cells. Therefore, Akt may mediate the LPA/S1P-induced caspase-3 inhibition in HEY ovarian cancer cells. A schematic of the pathways leading to Akt activation by LPA and S1P in HEY cells is shown in Figure 9.

Discussion

Although the signaling pathways of p38, MEK/ERK, and Akt activation induced by various stimuli, including LPA and S1P, have been studied in many cellular systems, a number of novel and important signaling mechanisms have been revealed through the current study. First, our work indicates for the first time that p38 is a relatively general requirement for the S473 phosphorylation of Akt, with the exception of insulin-induced Akt activation. The signaling mechanisms leading to p38 activation, however, seem to be highly cell line- and stimulus-specific. Second, we have observed LPA/S1P-induced cross communication between the two major kinase cascades (MAPK and PI3-K/Akt) involved in cell proliferation and cell survival, respectively, in ovarian cancer cells. Finally, our study reveals a cell line- and stimulus-specific MEK-dependent Akt activation, and we have explored the potential role of LPA and S1P receptors that confer a MEK-dependent Akt activation.

TABLE 1

Summary of MEK/p38-dependent or -independent Akt S473 phosphorylation in cells

Cells were pretreated with PD98059 (30 μ M) or SB203580 (10 μ M) for 30 min, then treated with LPA (10 μ M) or S1P (1 μ M) for 20 min. Western analyses of cell lysates were probed with phospho-specific Akt S473 or Akt antibodies. Fold-change in Akt phosphorylation is normalized to the levels of total Akt.

Cell Type	Cell Line	Change in Akt S473 Phosphorylation		Inhibition by PD98059		Inhibition by SB203580	
		LPA	S1P	LPA	S1P	LPA	S1P
		<i>-fold</i>		<i>%</i>		<i>%</i>	
Ovarian Cancer	HEY	8.2 \pm 0.9	10.1 \pm 1.2	94 \pm 5	91 \pm 6	99 \pm 1	99 \pm 1
	Ovca420	3.9 \pm 1.3	3.6 \pm 1.4	78 \pm 10	79 \pm 8	83 \pm 10	88 \pm 8
	Ovca429	2.3 \pm 0.7	2.4 \pm 0.5	83 \pm 5	92 \pm 4	99 \pm 2	99 \pm 1
	Ovca432	3.9 \pm 1.1	4.4 \pm 0.8	80 \pm 8	88 \pm 3	80 \pm 9	94 \pm 8
	Ovca433	2.3 \pm 0.3	2.8 \pm 0.7	77 \pm 5	86 \pm 4	92 \pm 5	97 \pm 4
	A2780	2.6 \pm 0.2	3.7 \pm 0.4	78 \pm 5	84 \pm 6	85 \pm 6	92 \pm 3
Other	HeLa	5.1 \pm 1.4	6.4 \pm 2.1	89 \pm 7	86 \pm 10	97 \pm 2	99 \pm 1
	MCF10A	1.1 \pm 0.2	0.9 \pm 0.1	N.A.	N.A.	N.A.	N.A.
	MDA-MB-231	3.3 \pm 1.5	4.0 \pm 1.1	20 \pm 5	27 \pm 6	40 \pm 3	39 \pm 5
	T-47D	5.2 \pm 0.7	4.3 \pm 0.9	92 \pm 5	90 \pm 3	97 \pm 2	95 \pm 4
	GI-101A	6.8 \pm 2.4	5.8 \pm 1.2	0 \pm 10	0 \pm 10	80 \pm 10	96 \pm 3
	PC-3	1.7 \pm 0.3	1.7 \pm 0.2	0 \pm 10	0 \pm 10	96 \pm 8	93 \pm 12

N.A., not applicable.

p38 Is a Relatively General Requirement for the S473 Phosphorylation of Akt. Full activation of Akt requires phosphorylation at both S473 and T308, which is usually regulated by different signaling mechanisms (Alessi et al., 1997; Pullen et al., 1998). T308 is phosphorylated by PDK1, which has been cloned and identified (Alessi et al., 1997). Our current understanding of the mechanism of S473 phosphorylation and the identification of PDK2 is still elusive and controversial. At least four different kinases have been suggested to be potential candidates of PDK2: Akt itself, PDK1, ILK1, and MK2 (Chan and Tsichlis, 2001). Because S473 can be phosphorylated when Akt is inactive, Akt autophosphorylation clearly cannot account for all of the S473 phosphorylation induced under different conditions. Although it has been suggested that PDK1 can acquire PDK2 activity, PDK1 is not necessary for S473 phosphorylation, which can occur even in PDK1-knockout ES cells. In cells stimulated with insulin, ILK is activated and enhances S473 phosphorylation through a PI3-K-dependent mechanism. However, it is likely that ILK may contribute indirectly to S473 phosphorylation

TABLE 2

Relative quantitation of Edg receptors in a variety of epithelial cells
The relative expression of LPA₂ in HEY cells was chosen as 1-fold. The relative amounts of other receptors are expressed as a fold change compared with LPA₂ in HEY cells.

Cell Line	$2^{-\Delta\Delta CT}$						
	S1P Receptors				LPA Receptors		
	S1P ₁	S1P ₂	S1P ₃	S1P ₅	LPA ₁	LPA ₂	LPA ₃
HEY	4.2	1.1	3.0	0.3	2.2	1.0	7.6
Ovca420	0.3	10.4	4.6	14.5	172.4	21.4	0.2
Ovca429	3.7	11.6	26.4	0.4	12.6	4.9	1.9
Ovca432	1.1	8.3	46.9	0.2	15.9	6.1	13.0
Ovca433	15.6	7.5	1.6	0.3	6.0	2.3	1.8
A2780	0.8	18.5	21.6	0.6	6.2	3.9	7.6
HeLa	0.0	4.6	6.0	0.4	0.0	1.4	2.8
MCF10A	0.2	1.6	1.5	0.1	0.7	10.7	0.8
MDA-MB-231	0.1	4.3	2.1	0.1	83.9	5.8	1.9
T-47D	0.0	7.8	11.4	7.9	37.3	28.4	0.1
GI-101A	0.0	10.3	0.3	0.4	0.1	11.5	15.7
PC-3	0.1	1.9	0.1	0.0	37.5	2.9	29.9

C_T = threshold cycle; ΔC_T = C_T for target gene - C_T for GAPDH gene; $\Delta\Delta C_T$ = ΔC_T relative to HEY LPA₂ (ΔC_T for target gene in test cell line - ΔC_T for LPA₂ in HEY cells); $2^{-\Delta\Delta C_T}$ = measurement of expression of target gene relative to LPA₂ in HEY cells.

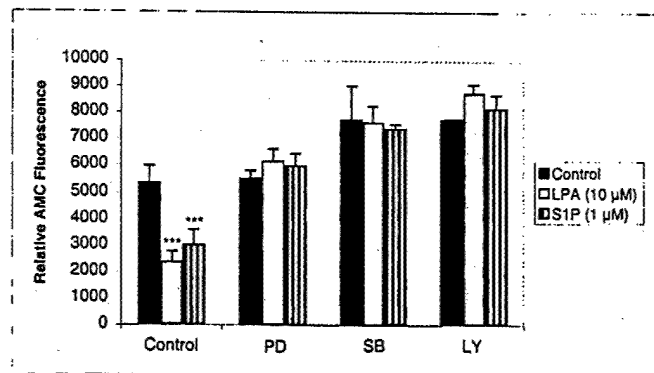

Fig. 8. LPA and S1P reduced paclitaxel-induced caspase-3 activity. HEY cells were pretreated with 30 μM PD98059 (PD), 10 μM SB203580 (SB), or 10 μM LY294002 (LY) for 30 min, then treated with LPA (10 μM) or S1P (1 μM) for 20 min, followed by exposure to paclitaxel (1 μM) for 24 h. Caspase-3 activity was determined by cleavage of the fluorogenic substrate, *N*-acetyl-Asp-Glu-Val-Asp-amino-4-methylcoumarin. ***, $p < 0.001$ (Student's *t*-test).

of Akt by providing an adaptor function. The major obstacle for recognizing MK2 as one of the PDK2 candidates arises from the fact that MK2 is not involved in S473 phosphorylation induced by insulin in HEK 293 cells (Alessi et al., 1996). However, the recent work by Rane et al. (2001) illustrates the possibility that MK2 functions as PDK2 under certain conditions. Our data seem to support works from both Alessi et al. (1996) and Rane et al. (2001) suggesting that at least two types of signaling pathways are involved in S473 phosphorylation. One type of signaling pathway, which does not require MK2 and/or p38 for S473 phosphorylation, may be represented by cells that respond to insulin, insulin-like growth factor, heat shock, or hydrogen peroxide (Shaw et al., 1998). Another signaling pathway, in which MK2 functions as PDK2, may be represented by cells, such as neutrophils, stimulated by fMLP, Fc-γR cross-linking, PIP₃ (Rane et al., 2001), and other potential stimuli.

We found that the activation of p38 seems to be a relatively generic requirement for Akt phosphorylation at S473, in that all 11 cell lines and most stimuli that we tested were SB203580-sensitive (Table 1). On the other hand, T308 phosphorylation induced under these conditions does not require p38 activation, suggesting that p38 is involved in the regulation of PDK2, but not PDK1, activity. We did not provide direct evidence in this study as to whether MK2 (or a different downstream target of p38) or p38 itself functions as PDK2 in these systems. However, a rather general requirement of p38 for efficient S473 phosphorylation, and the specific requirement of MEK/ERK signaling for efficient phosphorylation of both S473 and T308 by LPA, S1P, and PDGF in a number of cell lines have revealed the important link between MAPK and PI3K-Akt signaling pathways.

T308 is directly phosphorylated by PDK1 (Alessi et al., 1997). Our work suggests that MEK may be involved, either directly or indirectly, in the regulation of the action of PDK1. Whereas the mechanism of the MEK requirement for T308 phosphorylation remains to be investigated, a potential connection between MEK/ERK and PDK1 has recently been implicated (Frödin et al., 2000). The 90-kDa ribosomal S6 kinase-2 (RSK2), which is activated by ERK-type MAPKs, has been shown to be an activator of PDK1 (Frödin et al., 2000). Interaction with ERK-stimulated S386-phosphory-

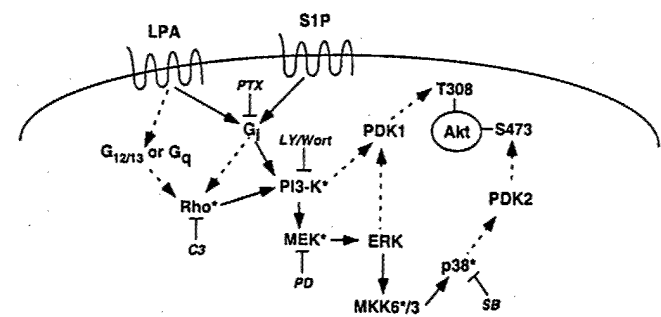

Fig. 9. Schematic of LPA/S1P-induced Akt activation in HEY ovarian cancer cells. Solid arrows indicate activation of signaling molecules but do not exclude mediation of this activation by additional effectors. A dashed arrow indicates that the relationship between the effector and activated molecule was not directly tested in this study. MK2 may function as PDK2 in our system, although this was not directly tested. *, dominant-negative and/or constitutively active alleles were used to study the involvement of that signaling molecule in this study. C3, C3-exoenzyme; LY, LY294002; PD, PD98059; PTX, pertussis toxin; SB, SB203580; Wort, wortmannin.

lated RSK2 led to autophosphorylation of PDK1 and increased PDK1 activity. However, the main regulators of PDK1 are likely to be phosphatidylinositol-(3,4)-biphosphate and/or PIP₃, and therefore MEK (or ERK) activation itself is insufficient to induce PDK1-mediated T308 phosphorylation of Akt.

The Signaling Pathways That Regulate p38 Activity Seem to Be Highly Specific. For example, although PI3-K is required for Akt activation in both keratinocytes (Zhang et al., 2001) and HEY cells (Fig. 1), we show that PI3-K is both necessary and sufficient to induce ERK and p38 activation in HEY cells (Fig. 4), whereas in keratinocytes, p38 is activated by a PI3-K-independent pathway (Zhang et al., 2001). Thus, p38 activation can be PI3-K-dependent or -independent, depending on the system. Furthermore, our results show that MEK is an upstream activator of p38 in MEK-dependent (and hence, p38-dependent) cellular systems. In MEK-independent cellular systems, p38 is still required for Akt activation. Thus, our results suggest that p38 can be activated by MEK-dependent or -independent pathways. The mechanisms regulating p38 activity in different systems require further investigation.

MEK/ERK and p38 are generally activated in parallel, not linear, signaling pathways (Cano and Mahadevan, 1995). The potential for MEK to act upstream of p38 has only been documented in two previous publications. Constitutively active MEK stimulates p38 in PC-12 cells (Morooka and Nishida, 1998); and MEK is required for Ras signaling to the p38 pathway (Chen et al., 2000). Furthermore, Chen et al. (2000) showed that MEK is necessary for, but MEK/2E is not capable of, p38 activation for Ras signaling in NIH3T3 cells. Here, we show that MEK is not only necessary for, but also capable of inducing p38 activation at levels comparable with those induced by LPA and S1P (Fig. 4C), suggesting that activation of p38 by LPA and S1P is mainly mediated through MEK activation.

Cross Communication between the MAPK and PI3-K/Akt Cascades. Although simultaneous stimulation of the ERK and PI3-K/Akt pathways has been reported previously, the requirement of MEK/ERK for Akt activation was either not examined or MEK/ERK and Akt were shown to be unrelated to each other. One of the novel and important findings of our work presented here is that MEK is a necessary and sufficient activator of Akt, and MEK functions upstream of p38 in G_γ/PI3-K/Akt signaling in a cell- and stimulus-specific manner. In particular, all six ovarian cancer cell lines tested demonstrate MEK/ERK-dependent Akt activation. These studies have revealed an integration of two important signaling pathways (MAPK and PI3-K/Akt) that govern two important tumorigenic processes (cell proliferation and survival, respectively). This is of potential therapeutic importance for ovarian cancer because both LPA and S1P 1) have been detected in ovarian cancer plasma and ascites (Xiao et al., 2000; Xiao et al., 2001), 2) protect ovarian cancer cells from paclitaxel-induced apoptosis in a manner dependent on the MAPK and PI3-K pathways (Fig. 8), 3) regulate pro-angiogenic factors in ovarian cancer (Hu et al., 2001; Schwartz et al., 2001) and 4) affect ovarian cancer cell proliferation, migration, and/or survival (Xu et al., 1995a, 2001; Frankel and Mills, 1996; Hong et al., 1999; Lu et al., 2002).

MEK-Dependent Akt Phosphorylation Is Cell Line- and Stimulus-Specific. Our study reveals a cell line- and

stimulus-specific MEK-dependent Akt activation. Interestingly, while this article was in preparation, a MEK-dependent Akt activation by ultraviolet B irradiation was reported by Nomura et al. (2001). Thus, our results are consistent with these recent findings. However, although Nomura et al., reported a MEK- and p38-dependent T308 phosphorylation of Akt by ultraviolet B radiation in mouse epidermal cells (Nomura et al., 2001), our results show for the first time that Akt T308 phosphorylation is dependent on MEK, but not p38, in HEY cells. Thus, similar to MEK-induced Akt S473 phosphorylation, the requirement of p38 activity for Akt T308 phosphorylation may be cell line- and/or stimulus-specific and remains to be further investigated.

As an initial step to understanding the molecular basis for conferring the cell line-specificity of LPA/S1P-induced MEK-dependent or -independent Akt activation, we examined the expression of LPA/S1P receptors in the cell lines used in this study (Table 2). For the LPA receptors, a simple correlation between any of three identified LPA receptors (LPA₁₋₃) with MEK-dependent or -independent cell lines was not revealed through our studies. These results suggest that although LPA₁, LPA₂, and/or LPA₃ may mediate LPA-induced Akt activation, at least one additional cellular factor is required to determine MEK dependence. In contrast, for S1P receptors, S1P₃ is potentially implicated as mediating MEK/p38-dependent Akt activation by S1P. S1P₃ is expressed in all of the cells that required, either partially or completely, both MEK and p38 for S1P signaling to Akt, and it is not expressed in the cells (PC-3 and GI-101A) that did not require MEK. In both PC-3 and GI-101A cells, S1P₂ is the only S1P receptor that is significantly expressed, indicating the possibility that a MEK-independent Akt stimulation by S1P is mediated through S1P₂. These implications remain to be further investigated.

In summary, this study has provided novel aspects related to LPA- and S1P-induced ERK, p38, and Akt signaling. In particular, these findings are of potential pathophysiological importance for understanding the overall involvement of the MAPK and PI3-K/Akt pathways in tumorigenesis, as well as for the development of novel therapies for ovarian cancer.

Acknowledgments

We thank Drs. Bryan R.G. Williams and Joe DiDinato for their critical reading of this manuscript.

References

- Alessi DR, Andjelkovic M, Caudwell B, Cron P, Morrice N, Cohen P, and Hemmings BA (1996) Mechanism of activation of protein kinase B by insulin and IGF-1. *EMBO (Eur Mol Biol Organ) J* 15:6541-6551.
- Alessi DR, James SR, Downes CP, Holmes AB, Gaffney PRJ, Reese CB, and Cohen P (1997) Characterization of a 3-phosphoinositide-dependent protein kinase which phosphorylates and activates protein kinase B- α . *Curr Biol* 7:261-269.
- Cano E and Mahadevan LC (1995) Parallel signaling processing among mammalian MAPKs. *Trends Biochem Sci* 20:117-122.
- Chan TO and Tsichlis PN (2001) PDK2: a complex tail in one Akt. *Sci STKE* 2001:PE1.
- Chen G, Hitomi M, Han J, and Stacey DW (2000) The p38 pathway provides negative feedback for ras proliferative signaling. *J Biol Chem* 275:38973-38980.
- Eder AM, Sasagawa T, Mao M, Aoki J, and Mills GB (2000) Constitutive and lysophosphatidic acid (LPA)-induced LPA production: role of phospholipase D and phospholipase A2. *Clin Cancer Res* 6:2482-2491.
- Fang X, Yu S, Lapushin R, Lu Y, Furui T, Penn LZ, Stokoe D, Erickson JR, Bast RC Jr, and Mills GB (2000) Lysophosphatidic acid prevents apoptosis in fibroblasts via G_γ-protein-mediated activation of mitogen-activated protein kinase. *Biochem J* 352:135-143.
- Fischer DJ, Nusser N, Virag T, Yokoyama K, Wang D, Baker DL, Bautista D, Parrill AL, and Tigyi G (2001) Short-chain phosphatidates are subtype-selective antagonists of lysophosphatidic acid receptors. *Mol Pharmacol* 60:776-784.
- Frankel A and Mills GB (1996) Peptide and lipid growth factors decrease cis-

- diamminedichloroplatinum-induced cell death in human ovarian cancer cells. *Clin Cancer Res* 8:1307-1313.
- Frödin M, Jensen CJ, Merienne K, and Gammeltoft S (2000) A phosphoserine-regulated docking site in the protein kinase RSK2 that recruits and activates PDK1. *EMBO (Eur Mol Biol Organ) J* 19:2924-2934.
- Goetzl EJ and An S (1998) Diversity of cellular receptors and functions for the lysophospholipid growth factors lysophosphatidic acid and sphingosine 1-phosphate. *FASEB J* 12:1589-1598.
- Graler MH, Bernhardt G, and Lipp M (1998) EDG6, a novel G-protein-coupled receptor related to receptors for bioactive lysophospholipids, is specifically expressed in lymphoid tissue. *Genomics* 53:164-169.
- Hong G, Baudhuin LM, and Xu Y (1999) Sphingosine-1-phosphate modulates growth and adhesion of ovarian cancer cells. *FEBS Letters* 460:513-518.
- Hu YL, Tee MK, Goetzl EJ, Auersperg N, Mills GB, Ferrara N, and Jaffe RB (2001) Lysophosphatidic acid induction of vascular endothelial growth factor expression in human ovarian cancer cells. *J Natl Cancer Inst* 93:762-768.
- Krump E, Sanghera JS, Pelech SL, Furuya W, and Grinstein S (1997) Chemotactic peptide *N*-formyl-Met-Leu-Phe activation of p38 mitogen-activated protein kinase (MAPK) and MAPK-activated protein kinase-2 in human neutrophils. *J Biol Chem* 272:937-944.
- Lee H, Goetzl EJ, and An S (2000) Lysophosphatidic acid and sphingosine 1-phosphate stimulate endothelial cell wound healing. *Am J Physiol* 278:C612-C618.
- Liu AX, Testa JR, Hamilton TC, Jove R, Nicosia SV, and Cheng JQ (1998) AKT2, a member of the protein kinase B family, is activated by growth factors, v-Ha-ras and v-src through phosphatidylinositol 3-kinase in human ovarian epithelial cancer cells. *Cancer Res* 58:2973-2977.
- Lopez-Illasaca M, Crespo P, Pellici PG, Gutkind JS, and Wetzker R (1997) Linkage of G protein-coupled receptors to the MAPK signaling pathway through PI 3-kinase gamma. *Science (Wash DC)* 275:394-397.
- Lu J, Xiao YJ, Baudhuin LM, Hong G, and Xu Y (2002) Role of ether-linked lysophosphatidic acids in ovarian cancer cells. *J Lipid Res* 43:463-476.
- Marte BM, and Downward J (1997) PKB/Akt: connecting phosphoinositide 3-kinase to cell survival and beyond. *Trends Biochem Sci* 22:355-358.
- Moolenaar WH (1999) Bioactive lysophospholipids and their G protein-coupled receptors. *Exp Cell Res* 253:230-238.
- Morooka T and Nishida E (1998) Requirement of p38 mitogen-activated protein kinase for neuronal differentiation in PC12 cells. *J Biol Chem* 273:24285-24288.
- Nomura M, Kaji A, Ma WY, Zhong S, Liu G, Bowden GT, Miyamoto K, and Dong Z (2001) Mitogen- and stress-activated protein kinase 1 mediates activation of akt by ultraviolet b irradiation. *J Biol Chem* 276:25558-25567.
- Pullen N, Dennis PB, Andjelkovic M, Dufner A, Kozma SC, Hemmings BA, and Thomas G (1998) Phosphorylation and activation of p70s6k by PDK1. *Science (Wash DC)* 279:707-710.
- Rane MJ, Coxon PY, Powell DW, Webster R, Klein JB, Ping P, Pierce W, and McLeish KR (2001) p38 kinase-dependent MAPKAPK-2 activation functions as PDK2 for Akt in human neutrophils. *J Biol Chem* 276:3517-3523.
- Schwartz BM, Hong G, Morrison BH, Wu W, Baudhuin LM, Xiao Y, and Xu Y (2001) Lysophospholipids increase interleukin-8 expression in ovarian cancer cells. *Gyn Oncol* 81:291-300.
- Shaw M, Cohen P, and Alessi DR (1998) The activation of protein kinase B by H₂O₂ or heat shock is mediated by phosphoinositide 3-kinase and not by mitogen-activated protein kinase-activated protein kinase-2. *Biochem J* 336:241-246.
- Shen Z, Belinson J, Morton RE, and Xu Y (1998) Phorbol 12-myristate 13-acetate stimulates lysophosphatidic acid secretion from ovarian and cervical cancer cells but not from breast or leukemia cells. *Gynecol Oncol* 71:364-368.
- Spiegel S (1999) Sphingosine 1-phosphate: a prototype of a new class of second messengers. *J Leukoc Biol* 65:341-344.
- Van Brocklyn JR, Graler MH, Bernhardt G, Hobson JP, Lipp M, and Spiegel S (2000) Sphingosine-1-phosphate is a ligand for the G protein-coupled receptor EDG-6. *Blood* 95:2624-2629.
- Van Corven EJ, Hordijk PL, Medema RH, Bos JL, and Moolenaar WH (1993) Pertussis toxin-sensitive activation of p21ras by G protein-coupled receptor agonists in fibroblasts. *Proc Natl Acad Sci USA* 90:1257-1261.
- Weiner JA and Chun J (1999) Schwann cell survival mediated by the signaling phospholipid lysophosphatidic acid. *Proc Natl Acad Sci USA* 96:5233-5238.
- Xiao Y, Chen Y, Kennedy AW, Belinson J, and Xu Y (2000) Evaluation of plasma lysophospholipids for diagnostic significance using electrospray ionization mass spectrometry (ESI-MS) analyses. *Ann NY Acad Sci* 905:242-259.
- Xiao Y-J, Schwartz B, Washington M, Kennedy A, Webster K, Belinson J and Xu Y (2001) Electrospray ionization mass spectrometry analysis of lysophospholipids in human ascitic fluids: comparison of the lysophospholipid contents in malignant vs. nonmalignant ascitic fluids. *Anal Biochem* 290:312-313.
- Xu Y, Fang XJ, Casey G, and Mills GB (1995a) Lysophospholipids activate ovarian and breast cancer cells. *Biochem J* 309:933-940.
- Xu Y, Gaudette DC, Boynton JD, Frankel A, Fang XJ, Sharma A, Hurteau J, Casey G, Goodbody A, and Mellors A (1995b) Characterization of an ovarian cancer activating factor in ascites from ovarian cancer patients. *Clin Cancer Res* 1:1223-1232.
- Xu Y, Shen Z, Wiper DW, Wu M, Morton RE, Elson P, Kennedy AW, Belinson J, Markman M, and Casey G (1998) Lysophosphatidic acid as a potential biomarker for ovarian and other gynecologic cancers. *J Am Med Assoc* 280:719-723.
- Xu Y, Xiao Y, Baudhuin LM, and Schwartz BM (2001) The role and clinical applications of bioactive lysolipids in ovarian cancer. *J Soc Gynecol Investig* 8:1-13.
- Yuan ZQ, Sun M, Feldman RI, Wang G, Ma X-L, Jiang C, Coppola D, Nicosia SV, and Cheng JQ (2000) Frequent activation of AKT2 and induction of apoptosis by inhibition of phosphoinositide-3-OH kinase/Akt pathway in human ovarian cancer. *Oncogene* 19:2324-2330.
- Zhang QS, Maddock DA, Chen JP, Heo S, Chiu C, Lai D, Souza K, Mehta T, and Wan YS (2001) Cytokine-induced p38 activation feedback regulates the prolonged activation of AKT cell survival pathway initiated by reactive oxygen species in response to UV irradiation in human keratinocytes. *Int J Oncol* 19:1057-1061.

Address correspondence to: Dr. Yan Xu, Department of Cancer Biology, NB-40, Cleveland Clinic Foundation, Cleveland, OH 44195. E-mail: xuy@ccf.org

Role of ether-linked lysophosphatidic acids in ovarian cancer cells

Jun Lu,* Yi-jin Xiao,* Linnea M. Baudhuin,*[§] Guiying Hong,* and Yan Xu^{1,*†§}

Department of Cancer Biology,* Lerner Research Institute, and Department of Gynecology and Obstetrics,[†] Cleveland Clinic Foundation, 9500 Euclid Avenue, Cleveland, OH 44195; and Department of Chemistry,[§] Cleveland State University, 24th and Euclid Avenue, Cleveland, OH 44115

Abstract Naturally occurring alkyl- and alkenyl-lysophosphatidic acids (al-LPAs) are detected and elevated in ovarian cancer ascites compared with ascites from non-malignant diseases. Here we describe the biological functions and signaling properties of these ether-linked LPAs in ovarian cancer cells. They are elevated and stable in ovarian cancer ascites, which represents an *in vivo* environment for ovarian cancer cells. They stimulated DNA synthesis and proliferation of ovarian cancer cells. In addition, they induced cell migration and the secretion of a pro-angiogenic factor, interleukin-8 (IL-8), in ovarian cancer cells. The latter two processes are potentially related to tumor metastasis and angiogenesis, respectively. Al-LPAs induced diverse signaling pathways in ovarian cancer cells. Their mitogenic activity depended on the activation of the G_{1/0} protein, phosphatidylinositol-3 kinase (PI3K), and mitogen-activated protein (MAP) kinase kinase (MEK), but not p38 mitogen activated protein kinase (MAP kinase). S473 phosphorylation of protein kinase B (Akt) by these lipids required activation of the G_{1/0} protein, PI3K, MEK, p38 MAP kinase, and Rho. However, T308 phosphorylation of Akt stimulated by al-LPAs did not require activation of p38 MAP kinase. On the other hand, cell migration induced by al-LPAs depended on activities of the G_{1/0} protein, PI3K, and Rho, but not MEK. These data suggest that ether-linked LPAs may play an important role in ovarian cancer development.—Lu, J., Yj. Xiao, L. M. Baudhuin, G. Hong, and Y. Xu. Role of ether-linked lysophosphatidic acids in ovarian cancer cells. *J. Lipid Res.* 2002. 43: 463–476.

Supplementary key words protein kinase B • mitogen activated protein kinase • alkyl-lysophosphatidic acid • alkenyl-LPA • ovarian cancer

Lysophosphatidic acid (LPA) is a bioactive lysolipid that is involved in a broad range of biological processes in a variety of cellular systems (1, 2). LPA induces cell proliferation or differentiation, prevents apoptosis induced by stress or stimuli, induces platelet aggregation and smooth muscle contraction, and stimulates cell morphologic changes, cell adhesion, and cell migration (1–5). LPA has been shown to be involved in angiogenesis, wound healing, and inflammatory processes (6–15). LPA exerts many of its effects by binding to G protein-coupled receptors (GPCRs), resulting in a cascade of intracellular signaling

activations (2, 16). Three endothelial differentiations genes [endothelial differentiations gene (Edg) 2, 4, and 7] have been identified as receptors for LPA (7, 17–19). LPA stimulates G_q-mediated extracellular mitogen-regulated kinase (ERK) and phosphatidylinositol 3-kinase (PI3K)-protein kinase B (Akt) activation, G_q-mediated phospholipase C (PLC) and protein kinase C (PKC) activation, and G_{12/13}-mediated Rho activation (1, 2).

We have previously identified a growth-stimulating factor, ovarian cancer activating factor (OCAF), in ascites from patients with ovarian cancer. OCAF is composed of various species of LPAs (with different fatty acid side chains) (20). OCAF and synthetic 18:1-acyl-LPA stimulate growth of ovarian, breast, and Jurkat cells (21, 22). Acyl-LPA (18:1) also regulates other cellular activities. It enhances cell adhesion/attachment (23), stimulates interleukin-8 (IL-8) production from ovarian cancer cells (24), and synergizes with other agents, such as thrombin agonists, nor-adrenaline, ADP, and arachidonic acid, to induce strong platelet aggregation (5). LPA has been shown to decrease *cis*-diamminedichloroplatinum-induced cell death (25), prevent cell apoptosis (26), and induce urokinase secretion (27) and vascular endothelial growth factor expression in human ovarian cancer cells (15). In addition, we have shown that acyl-LPAs are elevated in plasma from patients with ovarian cancer and may represent a useful marker for the early detection of ovarian cancer (28).

Abbreviations: Akt, protein kinase B; al-LPAs, alkyl- and alkenyl-lysophosphatidic acids; Edg, endothelial differentiations gene; ECL, enhanced chemiluminescence; ERK, extracellular mitogen-regulated kinase; ESI-MS, electrospray ionization mass spectrometry; GPCR, G protein-coupled receptor; IL-8, interleukin-8; LPA, lysophosphatidic acid; MAP kinase, mitogen activated protein kinase; MEK or MKK, MAP kinase kinase; MS-MS, tandem mass spectrometry; MRM, multiple reaction monitoring; MTT, 3-(4,5-dimethylthiazol-2-yl)-2,5-diphenyltetrazolium bromide; OCAF, ovarian cancer activating factor; PI3K, phosphatidylinositol 3-kinase; PLC, phospholipase C; PLD, phospholipase D; PKC, protein kinase C; PTX, pertussis toxin; S1P, sphingosine-1-phosphate.

¹ To whom correspondence should be addressed at the Department of Cancer Biology, Cleveland Clinic Foundation, 9500 Euclid Avenue, Cleveland, OH 44195.

e-mail: xuy@ccf.org

There are three subclasses of LPA: acyl-, alkyl-, and alkenyl-LPAs. The latter two subclasses of LPAs (al-LPAs) differ from acyl-LPA in that the fatty acid chain is linked to the glycerol backbone through an ether or a vinyl, rather than an ester bond. The majority of research work on LPA has been performed on acyl-LPAs (19, 29), although the effect of synthetic alkyl-LPA on platelet aggregation was reported decades ago (30). Most alkyl-LPA work was performed using synthetic alkyl-LPA (30, 31), and the naturally occurring al-LPAs have been reported only in recent years (12, 32–34).

We have recently developed an electrospray ionization mass spectrometry (ESI-MS)-based method to analyze lysolipids in body fluids (35) and found that, in addition to acyl-LPAs, ascites from patients with ovarian cancer contain elevated al-LPAs (including 16:0-/18:0-alkyl-LPA and 16:0-/18:0-alkenyl-LPA), when compared with ascites from patients with benign diseases and endometrial cancer (35). These results implicate that al-LPAs may have potential pathophysiological roles in ovarian cancer.

In the present study, we describe that al-LPAs were more stable than acyl-LPAs in ascites. These lipids stimulated DNA synthesis and proliferation of ovarian cancer cells through G_i , PI3K-, and mitogen activated protein (MAP) kinase kinase (MEK)-dependent pathways. Al-LPAs and acyl-LPAs induced migration of ovarian cancer cells through collagen I-coated membranes and this activity required the activation of G_i , and was partially dependent on PI3K activity. In addition, al-LPAs stimulated IL-8 production. Similar to acyl-LPAs as we observed recently (unpublished observations), al-LPAs activated Akt kinase and induced a Rho-, PI3K-, and MEK-dependent S473 phosphorylation of Akt.

MATERIALS AND METHODS

Chemicals

LPAs (16:0, 18:0, and 18:1), lyso-platelet activating factor (lyso-PAF), and other lysophospholipids were purchased from Avanti Polar Lipids (Birmingham, AL). Lyso-plasmalogen phosphatidylethanolamine (alkenyl-LPE) was obtained from Maureya, Inc. (Pleasant Cap, PA). LY294002, PD98059, and SB203580 were obtained from Biomol (Plymouth Meeting, PA). Wortmannin was obtained from Sigma (St. Louis, MO). Pertussis toxin (PTX) was purchased from Life Technologies, Inc. (Rockville, MD). Pre-coated silica gel 60 TLC plates were obtained from EM Science (Gibbstown, NJ). HPLC grade methanol (MeOH), chloroform, ammonium hydroxide, 3-(4,5-dimethylthiazol-2-yl)-2,5-diphenyltetrazolium bromide (MTT), and hydrochloric acid (HCl) were purchased from Sigma (St. Louis, MO) or Fisher Scientific (Pittsburgh, PA). [3 H]thymidine was from NEN Life Science Products, Inc. (Boston, MA). Anti-phospho-S473-Akt, anti-phospho-T308-Akt, anti-phospho-ERK, and anti-ERK were obtained from Cell Signaling Technology (Beverly, MA). Anti-MEK2 and anti-p38 were from StressGen (Victoria, BC, Canada).

Cell lines and cell culture

HEY and SKOV3 cells were from Dr. G. Mills (The University of Texas M. D. Anderson Cancer Center, Houston, TX) and American Type Culture Collection (Manassas, VA), respectively, and maintained in RPMI 1640 medium containing 10% FBS at 37°C

with 5% CO₂. All cells were cultured in serum-free media for 18–24 h prior to lipid treatment except in the cell migration experiments. For transient transfections, cells were plated into 35 mm dishes and transfected with DNA using LipofectAMINE (Life Technologies, Inc.) and Transfection Booster Reagents (Gene Therapy Systems, San Diego, CA) according to the manufacturers' instructions. Dominant negative MEK was from Dr. D. Templeton, Case Western Reserve University. Kinase inactive p38 was from Dr. Bryan R.G. Williams, Cleveland Clinic Foundation. The C3-exoenzyme construct was provided by Dr. Alan Wolfman, Cleveland Clinic Foundation. Dominant negative Akt was from Dr. Kumliang Guom, University of Michigan.

Nonradioactive immunoprecipitation Akt kinase assay

The Akt kinase assay was performed with the Nonradioactive Akt Kinase Assay Kit (Cell Signaling Technology, Beverly, MA) according to the manufacturer's instructions. All reagents were provided with the kit. Briefly, cells were treated with al-LPAs, rinsed with ice-cold phosphate-buffered saline, and then lysed in cell lysis buffer. Immunoprecipitation was carried out using immobilized Akt 1G1 monoclonal antibody. The immunoprecipitate was then incubated with GSK-3 fusion protein and ATP in kinase buffer. Western analysis was used to determine the extent of GSK-3 phosphorylation by active Akt using a phospho-GSK-3 α/β (Ser21/9) antibody.

Extraction and quantitation of alkyl- and alkenyl-LPAs from ascites

Extraction of alkyl- and alkenyl-LPAs from ascites was performed as described previously (35, 36). The stability of different LPA species was tested. Briefly, ascites samples were stored at 4°C for different time periods and lipids in ascites were extracted with chloroform and methanol in the presence of HCl. The chloroform phase was dried and lipids were separated on TLC plates. Different LPA species were eluted from TLC plates with a mixture of methanol and chloroform (2:1, v/v). ESI-MS and tandem mass spectrometry (MS-MS) analyses for the quantitation of alkyl- and alkenyl-LPAs were performed using a Micromass Quattro II Triple Quadrupole Mass Spectrometer. All quantitative analyses were performed in the multiple reaction monitoring (MRM) mode as described previously (35).

Preparation of alkyl- and alkenyl-LPAs

Alkyl- and alkenyl-LPAs were prepared through hydrolysis of the corresponding lyso-PAF or lyso-plasmalogen phosphatidylethanolamine (alkenyl-LPE), respectively, by phospholipase D (PLD) (Calbiochem, La Jolla CA). Briefly, 1 mg of alkenyl-LPE or lyso-PAF was dispersed in 0.1 ml of 0.04 M Tris buffer, pH 8.0, containing 0.05 M CaCl₂ and 1% Triton-X100. After addition of the enzyme (four units of PLD in 15 μ l of 0.01 M Tris-HCl, pH 8.0), the sample was mixed vigorously. The reaction vessel was sealed tightly and the contents were rotated overnight at room temperature. After the incubation period, the mixture was extracted with 1.2 ml mixture of chloroform-MeOH-HCl (5:4:0.2, v/v/v). The chloroform layer was evaporated under a stream of nitrogen and the residue was dissolved in 50 μ l chloroform-MeOH (1:2, v/v). The substrate and the product were separated on a TLC plate using a solvent system of chloroform-MeOH-NH₄OH (65:35:5.5, v/v/v) and the product was eluted from the plate by extracting with 2 ml of chloroform-methanol (1:2, v/v) twice and then dried under N₂. The lipid product was identified and quantified by ESI-MS and then dissolved in methanol to make a 1 mM solution.

DNA synthesis and MTT assays

HEY cells were plated in 96-well plates, serum-starved for 16–24 h, and treated for 24 h with different concentrations of al-LPAs

in F12-DMEM (1:1, v/v) medium supplemented with 0.1% fatty acid-free BSA, insulin, transferrin, and selenium. For the DNA synthesis assays, the cells were incubated with 0.15 $\mu\text{Ci}/\text{well}$ [^3H]thymidine for the last 18 h. Cells were harvested onto filter papers presoaked in 1% polyethyleneimine using an automated cell harvester, HARVEST 96 (Perkin-Elmer-Wallac, Inc.). Incorporated [^3H]thymidine was counted in a 1450 Microbeta Trilux Liquid Scintillation and Luminescence Counter (Perkin-Elmer-Wallac, Inc.). For cell proliferation, 3-(4,5-dimethylthiazol-2-yl)-2,5-diphenyltetrazolium bromide (MTT) dye reduction assays were used. Twenty μl of MTT solution (5 mg/ml) was added to each well and incubated at 37°C for the last 6 h of lipid treatment. The reduced MTT crystals were dissolved in 100 $\mu\text{l}/\text{well}$ of a mixture of DMSO and 95% ethanol (1:1, v/v). The color developed was read by a plate reader (SpectraMax 340, Molecular Devices Corp, Sunnyvale, CA) at 595–655 nm.

Western blotting

HEY cells were plated in 6-well plates in RPMI 1640 with 10% FBS, serum-starved overnight, and then treated with or without aLPAs in serum-free media for the indicated times. Cells were lysed on ice with Laemmli buffer containing 5% mercaptoethanol. The lysates were separated with 12% SDS-polyacrylamide gels and transferred onto polyvinylidene difluoride membranes (Bio-Rad Laboratories, Hercules, CA). Antibodies against S473 phosphorylated Akt, T308 phosphorylated Akt, or phosphorylated ERK1/2 were used to probe the membrane and the enhanced chemiluminescence (ECL) system (Amersham Pharmacia Biotech Inc., Piscataway, NJ) was used for detection. To normalize the amounts of protein loaded in each lane, the membranes were stripped and re-probed with antibodies against total Akt or ERK.

Cell migration assays

Chemotaxis was performed in a mini-Boyden chamber (Neuro Probe, Inc., Cabin John, MD) using Nucleopore polycarbonate filters (8 μm pore size) coated with a type-I collagen solution (100 $\mu\text{g}/\text{ml}$) (Vitrogen100, Collagen Corporation, Fremont, CA). Different concentrations of LPAs were added to the lower chamber. Checkerboard assays were performed as described by Okamoto et al. (37). HEY cells were starved for 3 h, trypsinized and resuspended at a concentration of 2.5×10^5 cells/ml in serum-free medium. The cell suspension (50 μl) was then placed in the upper chamber. After 4 h at 37°C, the cells that attached to the filters were fixed in 100% methanol and stained with Hematoxylin solution (Richard-Allan Scientific, Kalamazoo, MI). Cells that migrated to the lower phase of the membrane were counted under the microscope.

IL-8 ELISA assays

Cells were grown in 96-well plates, starved overnight, and treated with lipids for 6 h. The supernatants were collected and stored at -80°C . The IL-8 concentration was measured using a quantitative sandwich enzyme-linked immunosorbent assay (ELISA) (R&D Systems, Minneapolis, MN) according to the manufacturer's protocol with minor modifications as described previously (24). All analyses were carried out in triplicate. Optical densities were determined using a SpectraMax 340 plate reader (Molecular Devices, Sunnyvale, CA) at 650–490 nm.

RESULTS

aLPAs were more stable than acyl-LPAs in ascites from patients with ovarian cancer

We have previously compared the lysolipid content in 15 pairs of ascites samples from patients with ovarian cancer and non-malignant diseases, and reported that aLPAs were elevated in ovarian cancer ascites (35). Four aLPA species were detected in ascites samples: 16:0- and 18:0-alkyl LPAs, and 16:0- and 18:0-alkenyl-LPAs. The distribution of different aLPA and acyl-LPA species in 15 ovarian cancer and 15 non-malignant ascites samples is shown in Table 1. aLPA species in ascites account for approximately 12% of total LPAs (both al- and acyl-LPAs). We observed that aLPAs were more stable in ascites stored at 4°C under sterile conditions (Fig. 1A). The average half-lives of acyl-LPAs and aLPAs in ascites stored at 4°C were approximately 12 months and more than 2 years, respectively (results obtained from five ascites samples) (Fig. 1B).

aLPAs stimulated DNA synthesis and growth of HEY ovarian cancer cells

To determine the potential pathophysiological role of aLPAs in ovarian cancer cells, we first examined the effects of aLPAs on DNA synthesis and proliferation in HEY ovarian cancer cells. Alkyl-LPA (16:0) and 16:0-/18:0-alkenyl-LPA (the ratio of 16:0 to 18:0 was approximately 1:1) were synthesized as described in Materials and Methods. Figure 2 shows the spectra of synthesized 16:0-/18:0-alkenyl- and 16:0-alkyl-LPAs. Each preparation contained a small amount of impurities, which were mainly derived from 16:0- and

TABLE 1. Statistical analysis of LPAs in 15 pairs of ascites samples from patients with ovarian cancer or non-malignant diseases*

	Alkyl-LPA		Alkenyl-LPA		Total al-LPAs	Acyl-LPA				Total acyl-LPAs	Total LPAs	
	16:0	18:0	16:0	18:0		16:0	18:2	18:1	18:0			
	μM		μM		μM	μM				μM	μM	
Ovarian cancer												
Minimum	0.3540	0.1046	0.0943	0.4688	1.0217	0.1498	0.0780	0.0017	0.0048	1.1002	2.6949	
Maximum	3.8929	1.2483	0.6663	2.3318	7.1772	37.1935	3.7894	8.0704	11.1937	54.3211	59.6573	
Mean	1.4800	0.6371	0.2906	1.3036	3.7113	11.2207	1.1806	2.4424	4.0650	18.9087	22.6134	
Median	1.2620	0.6577	0.2651	1.2278	3.6384	12.1470	0.4485	1.8458	1.7882	19.4320	22.5316	
Benign disease												
Minimum	0.0000	0.0000	0.0000	0.0164	0.0423	0.2779	0.0000	0.0392	0.0412	0.3966	0.4389	
Maximum	0.4450	0.2541	0.0585	0.4081	1.1072	5.1070	0.9057	0.9932	0.6924	6.9865	7.5109	
Mean	0.1430	0.0997	0.0082	0.1072	0.3580	1.8723	0.3325	0.3986	0.2582	2.8615	3.1956	
Median	0.0928	0.0820	0.0000	0.0602	0.2287	1.3920	0.3129	0.3707	0.2199	2.3900	2.5705	

* Sample collection, lipid extraction, and analyses were performed as described previously (35).

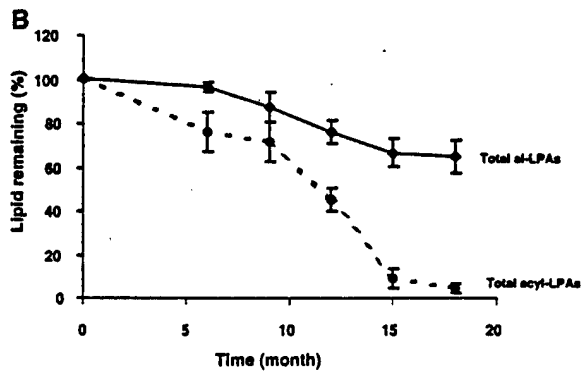
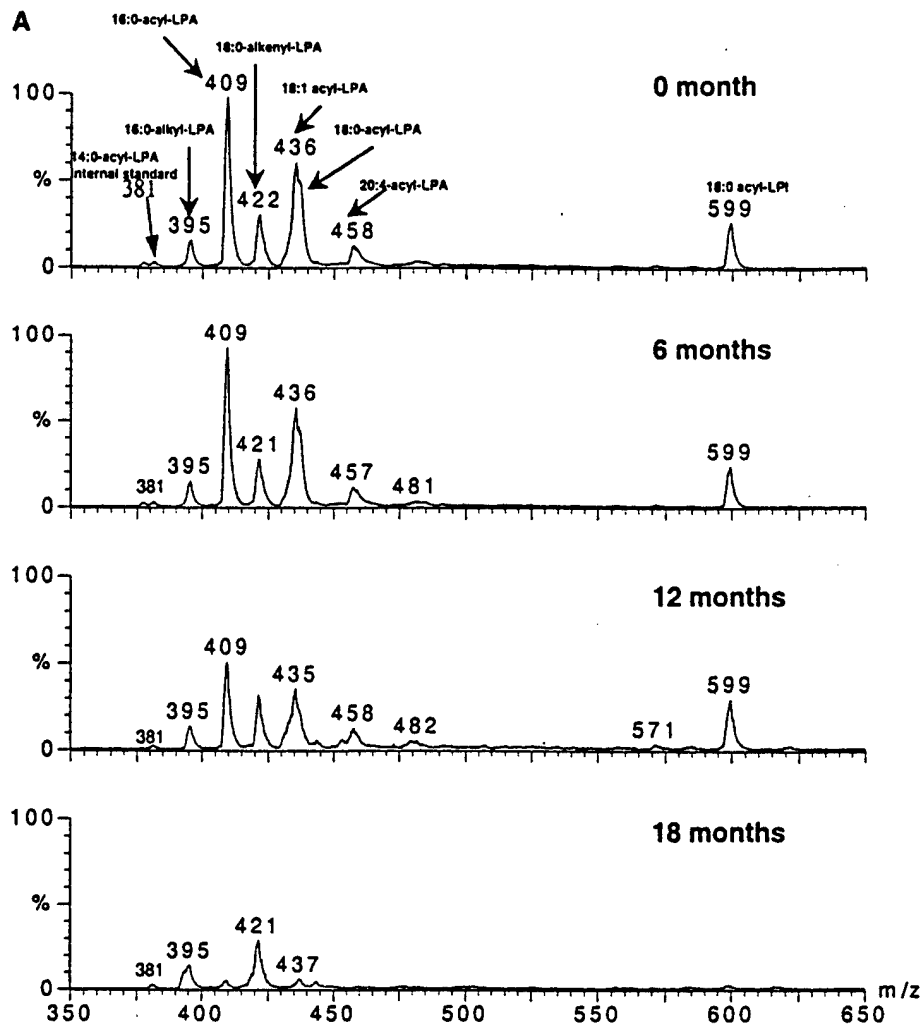

Fig. 1. Alkyl- and alkenyl-lysophosphatidic acids (al-LPAs) in ascites from ovarian cancer patients are more stable than acyl-LPAs. Al-LPAs and acyl-LPAs from ascites samples were extracted and analyzed as described in Materials and Methods. Five ascites samples from patients with ovarian cancer were stored at 4°C under sterile conditions. LPAs from 0.5 ml of ascites were analyzed at the time intervals as indicated. A: Electrospray ionization mass spectrometry (ESI-MS) spectra of LPAs from representative ovarian cancer ascites samples analyzed at 0, 6, 12, and 18 months. B: The stability of LPAs in five ovarian cancer ascites samples.

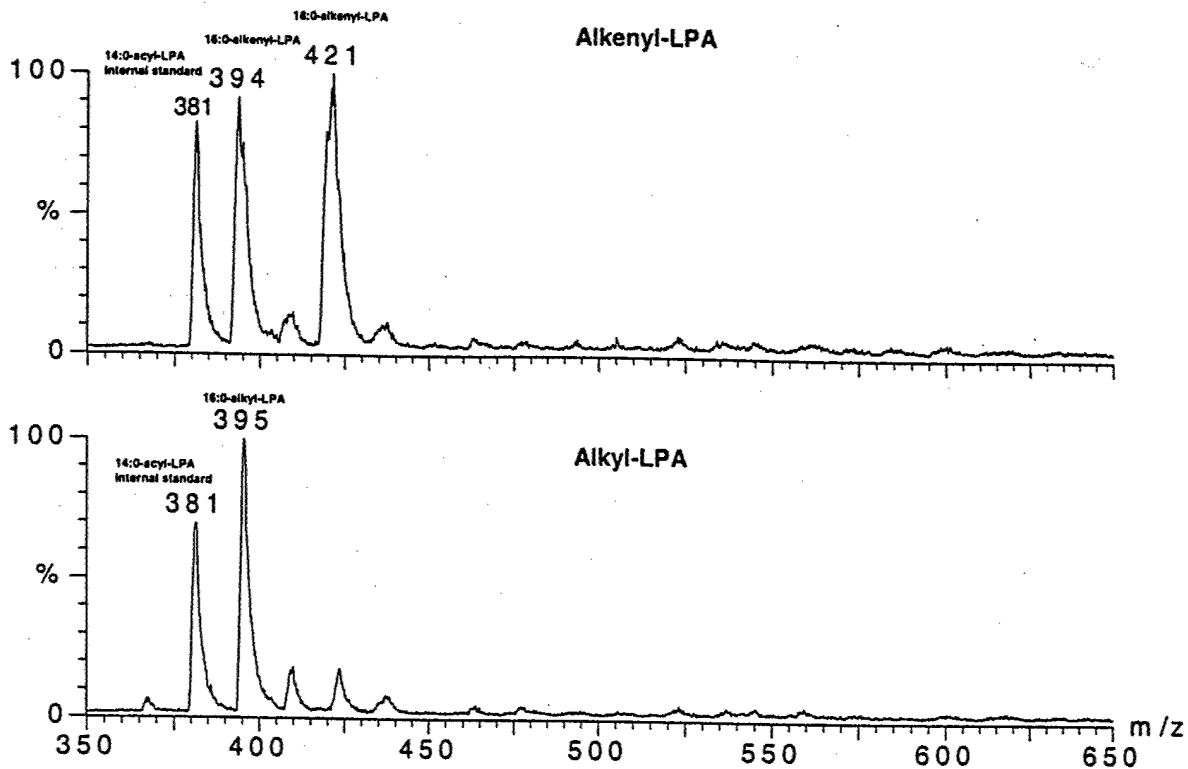

Fig. 2. The spectra of synthetic alkyl- and alkenyl-LPAs. al-LPAs were synthesized and analyzed as described in Materials and Methods. Al-LPAs were resuspended in methanol and 20 μ l of al-LPAs containing 50 pmol of 14:0-acyl-LPA (internal standard) was used for MS analyses.

18:0-acyl-LPAs. The relatively low amount (<10% and <5% in the alkyl-LPA and the alkenyl-LPA preparations, respectively) of these impurities did not affect the activities tested in this study. Starved HEY cells were incubated with different concentrations of lipids (0.1–5.0 μ M within the concentration range detected in ascites from patients with ovarian cancer) for 24 h. The effects of lipids on DNA synthesis were assessed by addition of [3 H]thymidine (0.15 μ Ci/well) and the effect of lipids on cell proliferation was measured by MTT dye reduction. Physiological concentrations of 16:0-

alkyl-LPA (1–5 μ M) and 16:0/18:0-alkenyl-LPA (1–5 μ M) increased [3 H]thymidine incorporation and MTT dye reduction to approximately 2-fold (Fig. 3A and B).

Al-LPAs activated ERK and Akt

We have shown in our recent studies that acyl-LPA induces ERK, p38, and Akt activation in HEY cells (unpublished observations). We sought to examine the activation of ERK and Akt induced by al-LPAs. Both alkyl- and alkenyl-LPAs activated Akt as assessed by an Akt kinase assay (Fig. 4A). West-

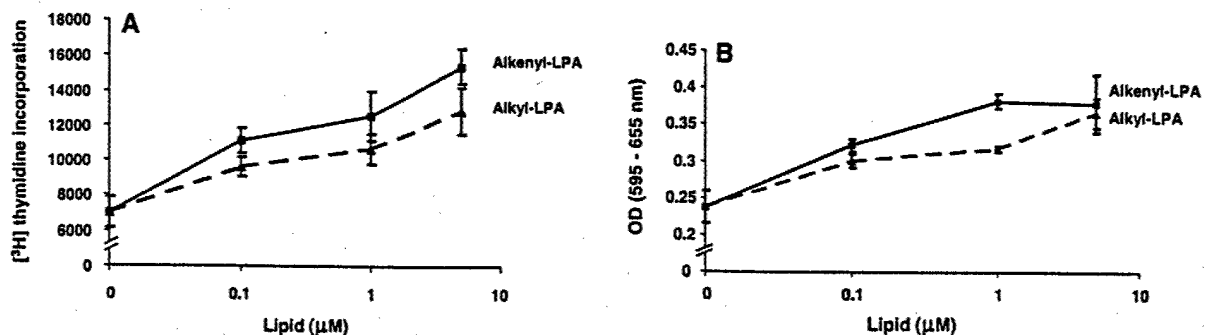

Fig. 3. Al-LPAs stimulated DNA synthesis in HEY cells. A: DNA synthesis was measured by using [3 H]thymidine incorporation as described in Materials and Methods. Starved cells were treated with al-LPAs (1–5 μ M) for 24 h. B: 3-(4,5-dimethylthiazol-2-yl)-2,5-diphenyltetrazolium bromide (MTT) dye reduction was used to measure cell proliferation. Starved cells were treated with al-LPAs (1–5 μ M) for 24 h. MTT solution was added and incubated at 37°C for the last 6 h of lipid treatment.

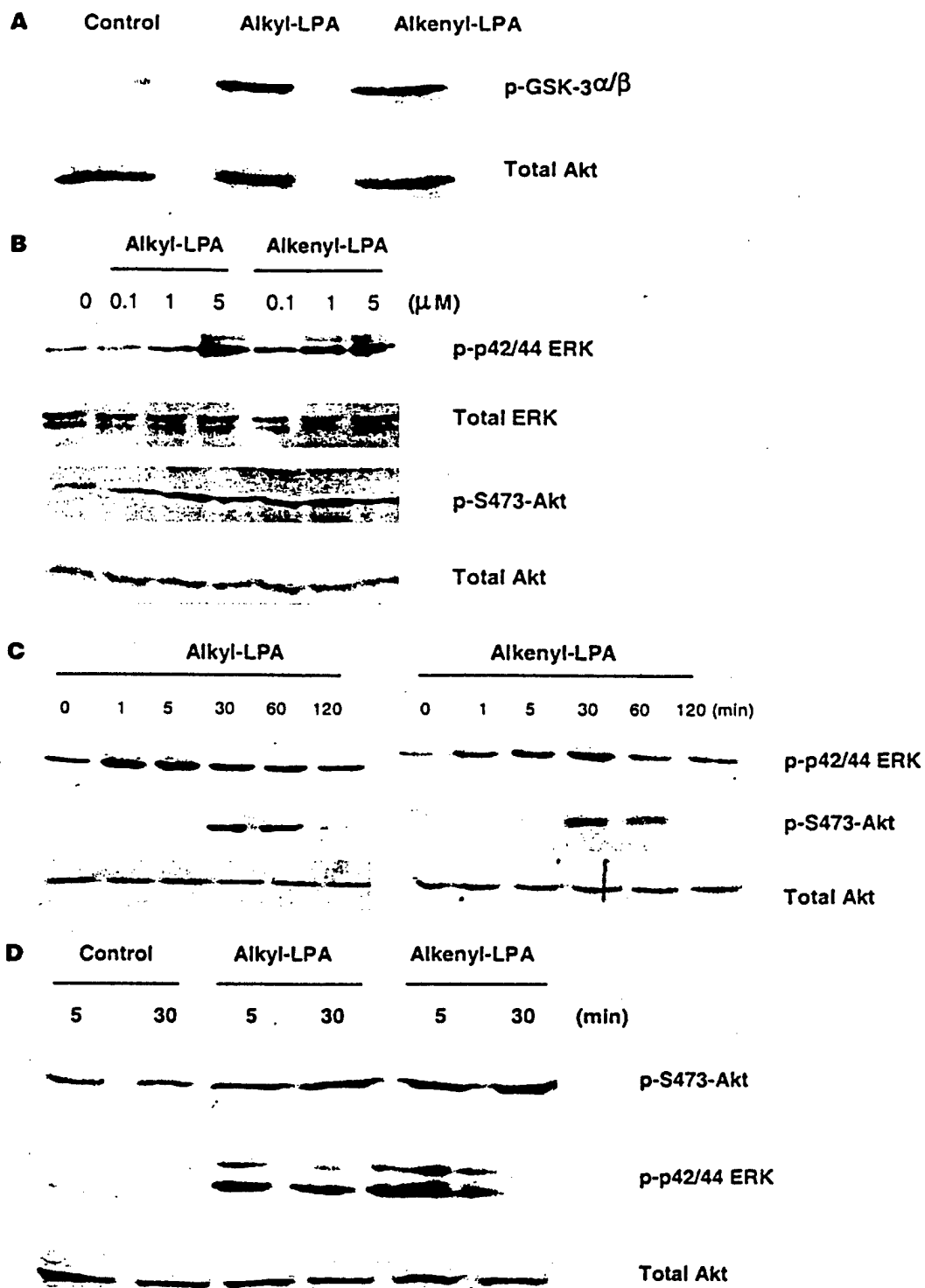

Fig. 4. Al-LPAs activated extracellular mitogen-regulated kinase (ERK) mitogen activated protein kinase (MAP kinase) and protein kinase B (Akt) in HEY and SKOV3 ovarian cancer cells. **A:** The kinase activity of Akt was performed with the Nonradioactive Akt Kinase Assay Kit according to the manufacturer's instructions. Starved HEY cells were treated with 2 μ M al-LPAs for 30 min. **B:** Concentration-dependent Akt (30 min) and ERK (5 min) phosphorylation by al-LPAs. HEY cells were serum-starved for 18–24 h before stimulation with lipids. **C:** The time courses of ERK and Akt phosphorylation stimulated by alkyl-LPA (2 μ M) or alkenyl-LPA (2 μ M) for the indicated times in HEY cells. **D:** ERK and Akt phosphorylation induced by al-LPAs in SKOV3 cells. Starved SKOV3 cells were treated with 2 μ M al-LPAs for the indicated times.

ern blot analyses of phosphorylated ERK and Akt (S473) were performed after HEY cells were treated with alkyl- or alkenyl-LPAs. Both alkyl- and alkenyl-LPAs (2 μ M) induced a concentration- and time-dependent activation of ERK and a transient increase in the S473 phosphorylation of Akt (Fig. 4B and C). The optimal concentrations were 5 μ M and 1 μ M for al-LPAs to activate ERK and Akt, respectively (Fig. 4B). Concentrations higher than 5 μ M were not tested, since they are out of the physiological concentration ranges of al-LPAs detected in ovarian cancer ascites (Table 1). The optimal times for induction of ERK and Akt phosphorylation by alkyl-LPA were 1–5 min and 30 min, respectively. Alkenyl-LPA induced maximal phosphorylation of both ERK and Akt at 30 min (Fig. 4C). Similarly, al-LPAs induced ERK and Akt phosphorylation in another ovarian cancer cell line, SKOV3 (Fig. 4D).

Pertussis toxin (PTX, a $G_{i/o}$ inhibitor; 100 ng/ml) partially, and two specific inhibitors of PI3K, LY294002 (10 μ M) and wortmannin (100 nM), completely inhibited the activation of ERK and Akt induced by al-LPAs, suggesting that a PTX-sensitive G protein and PI3K are involved in phosphorylation of ERK and Akt (Fig. 5A and B).

Acyl-LPA-induced Akt activation is dependent on the activities of both MEK and p38, which is both cell line and stimulus specific (unpublished observations). In addition to our work, this MEK-dependent Akt activation/phosphorylation has been shown very recently in ultraviolet B- and serotonin-induced Akt activation (38, 39). To investigate whether al-LPAs activated the same signaling pathways as acyl-LPAs in HEY cells, we tested the effects of a panel of pharmacological and genetic inhibitors on the Akt phosphorylation induced by al-LPAs. Similar to acyl-LPAs, Akt phosphorylation at S473 was sensitive to both PD98059 and SB203580 (the specific inhibitors for MEK1/2 and p38, respectively) (Fig. 5C), suggesting that MEK, and potentially its downstream effector ERK, and p38 were required for Akt phosphorylation at S473 by al-LPAs. This was further confirmed by transfecting HEY cells with dominant negative forms of MEK and p38 (MEK/2A and p38/AGF) (Fig. 5D). We have developed an efficient transfection method in HEY cells (unpublished observations). Using both LipofectAMINE and Transfection Booster Reagents #3 (from Gene Therapy System, Inc., San Diego, CA), the transfection efficiency was increased from $15 \pm 4\%$ to $77 \pm 6\%$ (unpublished observations). Both these dominant negative forms of MAP kinases blocked Akt activation induced by al-LPAs, indicating that both MEK and p38 activities are required for al-LPA-induced S473 phosphorylation of Akt in HEY cells.

Since phosphorylation of both T308 and S473 are necessary for the full activation of Akt, we examined the ability of al-LPA to stimulate Akt T308 phosphorylation. Both alkyl- and alkenyl-LPAs (2 μ M) were able to induce an approximately 3-fold increase in Akt phosphorylation at T308 in HEY cells (Fig. 5E). To determine whether phosphorylation at T308 required p38 MAP kinase, we pre-treated cells with SB 203580 (0.5, 2.5, and 10 μ M) followed by treatment with al-LPAs (Fig. 5E). Our results show that 0.5, 2.5, and 10 μ M of SB203580 inhibited approximately

20%, 80%, and 100% phosphorylation at S473, respectively. However, even at 10 μ M, the phosphorylation of T308 was not affected by SB 203580, suggesting that p38 MAP kinase was not required for this phosphorylation.

We have shown that acyl-LPA, but not a structurally similar lipid, sphingosine-1-phosphate (S1P), induces Akt phosphorylation via a Rho-dependent pathway (unpublished observations). We tested whether al-LPAs also require Rho for induction of S473 phosphorylation of Akt. Transient transfection of C3-exoenzyme, which blocks Rho activity, completely abolished al-LPA-induced S473 phosphorylation (Fig. 5F). Together, these results suggest that al-LPAs stimulate the same or similar signaling pathways in HEY cells as acyl-LPAs, and they may activate the same or similar receptors.

Activation of MEK/ERK, but not Akt, was required for promoting DNA synthesis by al-LPAs in HEY cells

To explore the potential signaling pathways involved in al-LPA induced DNA synthesis, we tested the effect of PTX, LY294002, wortmannin, PD98059, and SB203580 on [3 H]thymidine incorporation induced by alkyl- and alkenyl-LPAs (Fig. 6A). PTX inhibited approximately 70% and 45% of [3 H]thymidine incorporation triggered by alkyl-LPA and alkenyl-LPA, respectively, suggesting that both PTX-sensitive and insensitive G proteins are involved in this activity. LY294002 (10 μ M), wortmannin (100 nM), and PD98059 (30 μ M) completely blocked the al-LPA-stimulated DNA synthesis, suggesting that the activity of PI3K and MEK is essential for the process. In contrast, p38 activity was not required for DNA synthesis induced by al-LPAs, since [3 H]thymidine incorporation was insensitive to the treatment of SB203580. This was further confirmed by transfection with MEK/2A and p38/AGF (Fig. 6B). Expression of MEK/2A completely inhibited al-LPA-induced DNA synthesis (Fig. 6B). In contrast, expression of p38/AGF did not affect the DNA synthesis induced by al-LPAs (Fig. 6B), indicating that p38 was not required for DNA synthesis induced by al-LPAs. Since S473 phosphorylation of Akt required p38 activation (Fig. 5D), and p38 was not required for the DNA synthesis stimulated by al-LPAs, we predict that Akt activation was not required for al-LPA-induced DNA synthesis. To test this, we transfected the dominant negative (dn) form of Akt into HEY cells and found that dn-Akt did not affect [3 H]thymidine incorporation induced by al-LPAs as we predicted (Fig. 6B). These data suggest that al-LPA-induced MEK activation can lead to a p38- and Akt-independent stimulation of DNA synthesis in HEY cells.

Al-LPAs promoted ovarian cancer cell migration through collagen I-coated membranes

Cell migration is critically important for tumor metastasis. Acyl-LPA has been shown to induce cell migration of a number of cell types (fibroblasts, monocytes, T-lymphoma, hepatoma, and endothelial cells) (40–48). To test the effect of LPAs on ovarian cancer cell migration, we conducted Boyden chamber analyses. We found

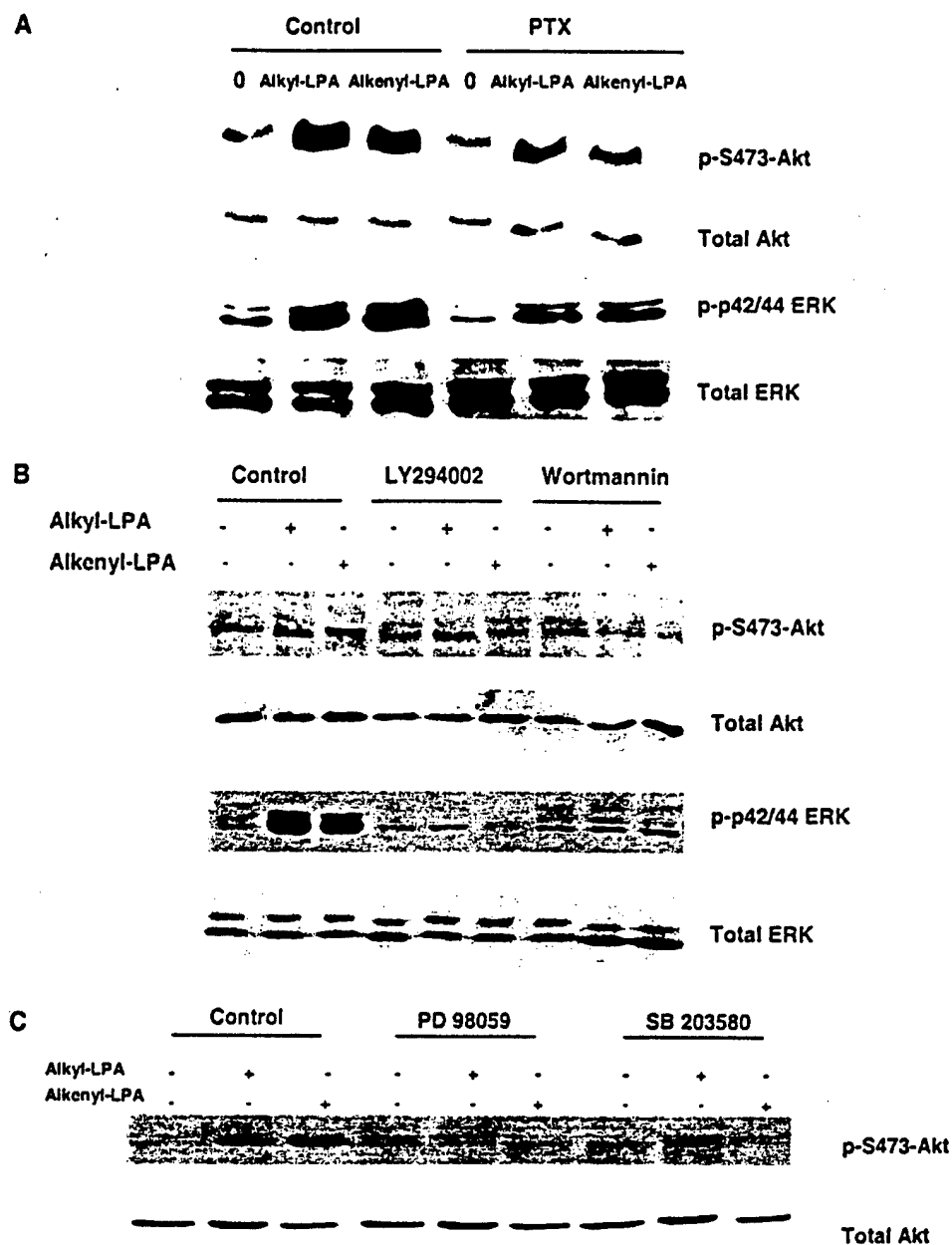

Fig. 5. Al-LPAs induced phosphorylation of ERK, and Akt was dependent on G_i , PI3K, MEK, and p38. **A:** Akt and ERK phosphorylation induced by al-LPAs was pertussis toxin (PTX)-sensitive. HEY cells were pretreated with PTX (100 ng/ml) for 16 h prior to stimulation with lipids (2 μ M) for detection of p-Akt (30 min stimulation) or p-p42/44 ERK (5 min stimulation). **B:** Al-LPA-induced Akt and ERK phosphorylation was inhibited by PI3K inhibitors. Starved HEY cells were pretreated with 10 μ M LY 294002 or 0.1 μ M wortmannin for 30 min prior to stimulation with lipids (2 μ M; 30 min for p-Akt and 5 min for p-ERK). **C:** S473 phosphorylation of Akt induced by al-LPAs was dependent on both MEK and p38 MAP kinases. Starved HEY cells were pretreated with 30 μ M PD98059 or 10 μ M SB203580 for 30 min followed by stimulation with lipid (2 μ M; 30 min for p-Akt and 5 min for p-ERK). **D:** HEY cells were transiently transfected with control vector, dominant negative MEK (MEK/2A), or kinase dead p38 (p38/AGF), and then treated with 2 μ M al-LPAs for 30 min. **E:** HEY cells were pretreated with different concentrations of SB 203580 (0, 0.5, 2.5, and 10 μ M) for 30 min, followed by al-LPAs (2 μ M) for 30 min. T308 and S473 phosphorylated Akt were detected by specific antibodies. **F:** S473 phosphorylation of Akt induced by al-LPAs was dependent on Rho activity. HEY cells were transiently transfected with control vector, C3-exoenzyme (C3), and then treated with 2 μ M al-LPAs for 30 min.

that both alkyl- and alkenyl-LPAs triggered cell migration through collagen I in a concentration-dependent manner, and alkenyl-LPA was more potent than alkyl-

LPA (Fig. 7A). To determine whether the enhanced cell migration was due to chemokinesis (random motility) or chemotaxis (directional motility), checkerboard analy-

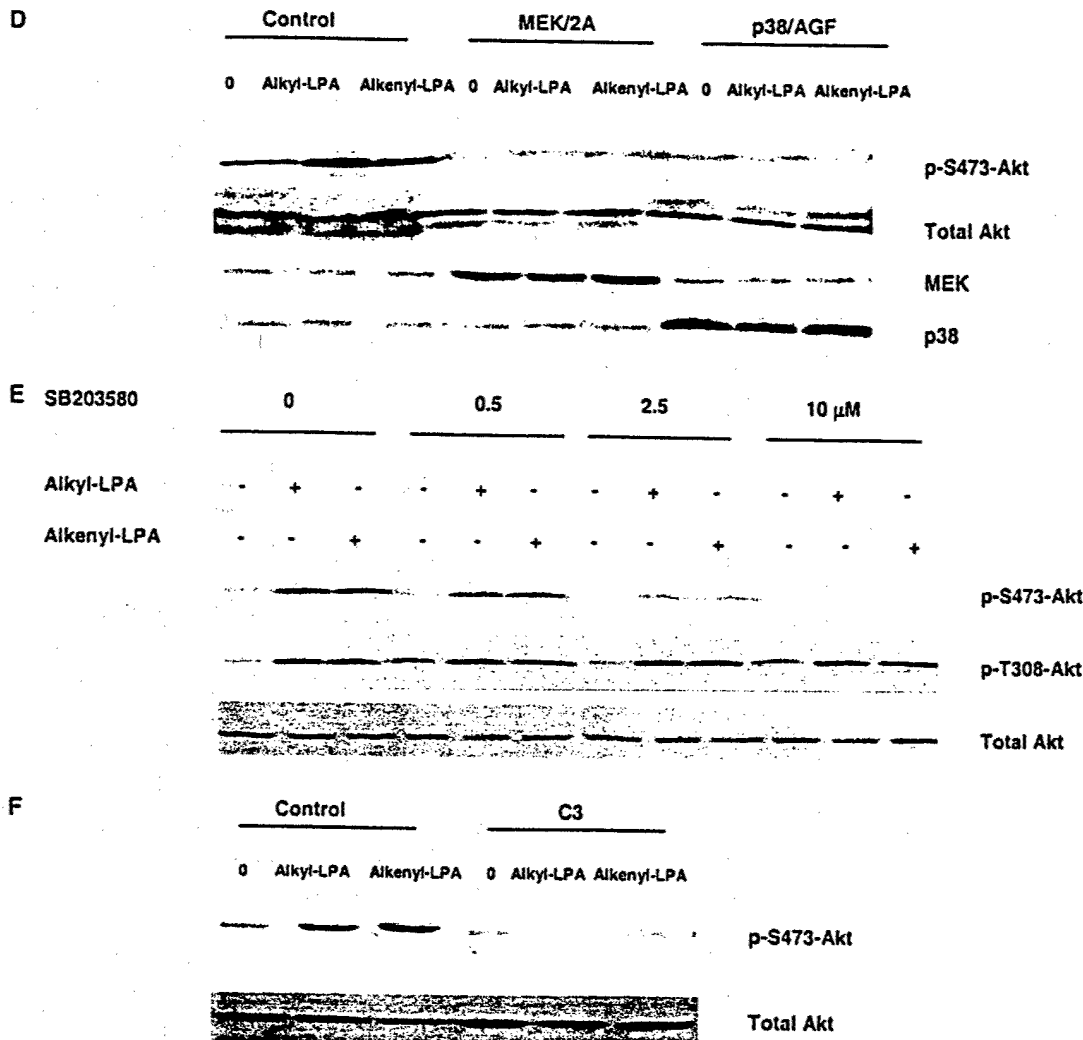

Fig. 5. (Continued)

ses were performed essentially as described by Okamoto et al. (37). The number of cells that migrated to the lower phase of the membrane was reduced significantly as the concentration gradient of al-LPAs decreased (Table 2), indicating that al-LPAs mainly stimulated chemotaxis.

We then compared the relative potencies of major LPA species present in ascites in stimulation of cell migration. We found that 16:0-acyl, 18:0-acyl, 18:1-acyl, 16:0-alkyl, and 16:0/18:0-alkenyl LPAs all stimulated migration of HEY ovarian cancer cells through collagen I-coated membranes (Fig. 7B). At 1 μ M concentration, the relative potencies of these LPA species were 18:1-acyl-LPA > 16:0/18:0-alkenyl-LPA > 16:0-alkyl-LPA > 16:0-acyl-LPA > 18:0-acyl-LPA (Fig. 7B). The cell migration induced by al-LPAs was sensitive to PTX pretreatment and C3 exoenzyme transfection, and partially blocked by LY294002 (Fig. 7C). Interestingly, transfection of MEK/

2A, which completely blocked al-LPA-induced Akt phosphorylation (Fig. 5D, top), did not significantly affect cell migration induced by al-LPAs, suggesting that a different downstream signaling molecule(s) of G_i , Rho, and/or PI3-K (other than MEK) was responsible for cell migration induced by al-LPAs.

Al-LPAs triggered IL-8 secretion from HEY cells

We have recently shown that 18:1-acyl-LPA induces increased IL-8 at both mRNA and protein levels in ovarian cancer cells, but not in immortalized ovarian epithelial cells (24). To determine whether al-LPAs also induce this activity, we examined IL-8 secretion from HEY cells using an ELISA assay as previously described (24). Al-LPAs induced IL-8 secretion from ovarian cancer cells with similar or higher potencies to that of 16:0- or 18:0-acyl-LPAs (Fig. 8).

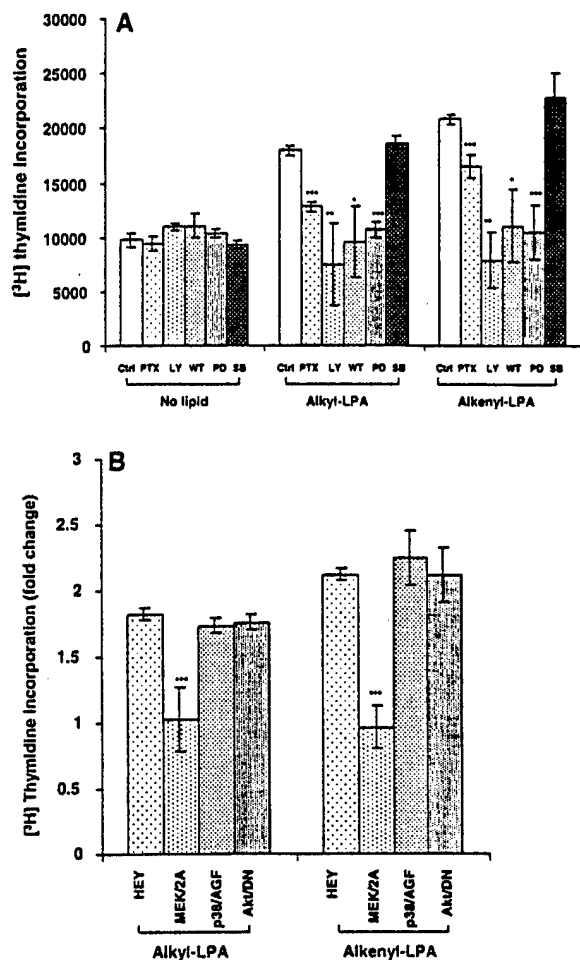

Fig. 6. Al-LPA-mediated proliferation was PTX-sensitive and dependent on PI3K and ERK activation, but not p38 MAP kinase. **A:** HEY cells were treated with alkyl-, alkenyl-LPAs, or solvent (control), and [³H]thymidine incorporation was conducted as described in Materials and Methods. PTX (100 ng/ml) was added to the culture 16 h prior to lipid (5 μM) stimulation. HEY cells were stimulated with alkyl-LPA or alkenyl-LPA (5 μM) in the presence of 30 μM PD 98059 (PD), 10 μM LY294002 (LY), 0.1 μM wortmanin (WT), or 10 μM SB 203580 (SB). The data shown here represent the mean ± SD of three independent experiments. **B:** HEY cells were transiently transfected with control vector, dominant negative MEK (MEK/2A), kinase dead p38 (p38/ACF), or dominant negative Akt (AKT/DN). After the starvation, the cells were incubated with 5 μM al-LPAs for 24 h. Results are plotted as mean ± SD of three independent experiments. ****P* < 0.001, ***P* < 0.01, **P* < 0.05 (Student's *t*-test).

DISCUSSION

We have previously reported that acyl-LPAs are growth stimulating factors for ovarian cancer and other tumor cells, which are present in ascites from patients with ovarian cancer (21, 22). The major acyl-LPA species (approximately 50% of all acyl-LPAs) in ovarian cancer ascites is 16:0-acyl-LPA (20). However, it is not a potent growth stimulator of ovarian cancer cells (21, 22). LPA species with un-

saturated fatty acids, such as 18:1- and 18:2-acyl LPAs, are more potent mitogens for ovarian cancer cells (20). We have recently detected elevated levels of al-LPAs in ovarian cancer ascites.

In this work, we show several lines of evidence to suggest that al-LPAs may play an important pathological role in ovarian cancer development. First, al-LPAs stimulated cell growth and DNA synthesis of HEY ovarian cancer cells (Fig. 3). Second, al-LPAs induced Akt activation (Fig. 4A), which may be related to cell survival and chemoresistance. Third, al-LPAs induced cell migration (Fig. 7A), which is one of the critical steps in tumor cell invasion and metastasis. Finally, al-LPAs stimulated the production of IL-8 with similar or higher potencies than 16:0- and 18:0-acyl-LPAs (Fig. 8). In particular, physiological concentrations of al-LPAs were used in this study, and our results support the notion that these lipids may play important pathological roles in ovarian cancer development, although the role of al-LPAs *in vivo* remains to be further investigated.

Ovarian tumor cells inherently possess a strong metastatic potential to the peritoneum, which is the major cause of death in ovarian cancer patients (49). Preferential adhesion of ovarian epithelial carcinoma cells to migrate through collagen I (vs. collagen IV, fibronectin, laminin, and vitronectin), has been demonstrated, and the ovarian carcinoma micro-environment is rich in collagen I (49). We show here that different LPA species promote cell migration through collagen I-coated membranes and that this activity is potentially important in ovarian cancer pathology.

IL-8 is a pro-inflammatory and pro-angiogenic factor and may be involved in ovarian tumor development (50, 51). Angiogenesis is a critical factor for tumor development, which induces the transition from a limited to a rapid tumor growth via neovascularization (52). High expression of IL-8 mRNA has been detected in clinical specimens of late-stage ovarian carcinomas (53, 54). Ascites/cyst fluid and/or plasma of patients with ovarian cancer contain significantly higher levels of IL-8 compared with patients with benign gynecological disorders (55, 56). We have shown that al-LPAs are elevated in malignant ascites (35). Our results shown here suggest that al-LPAs present in ascites may regulate IL-8 production *in vivo*.

The results shown here suggest that the biological activities and/or signaling properties of LPA species are not only dependent on the composition of the fatty acid side chain, but also the chemical linkage between the aliphatic chain and the glycerol backbone. Although 16:0- and 18:0-acyl-LPAs are not effective in growth stimulation in ovarian cancer cells (20), 16:0-alkyl- and 16:0/18:0-alkenyl-LPAs stimulated growth and DNA synthesis of HEY ovarian cancer cells. In addition, 16:0- and 18:0-al-LPAs were more potent than 16:0- and 18:0-acyl-LPAs in stimulating cell migration and IL-8 production. Interestingly, various synthetic ether-linked lysophosphatidylcholine compounds inhibit growth of many malignant cells, and clinical trials evaluating their antineoplastic potential have been conducted (57, 58). More recently, synthetic alkyl-LPA deriva-

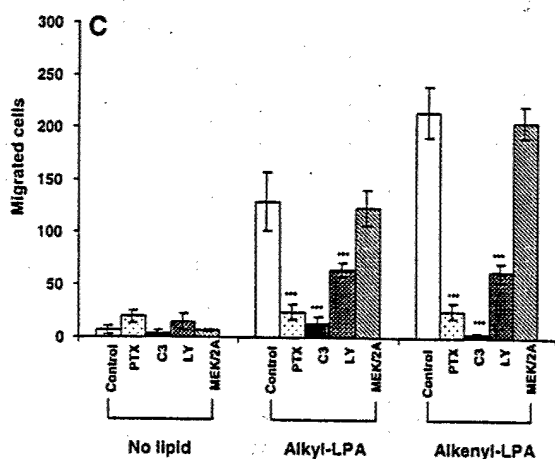
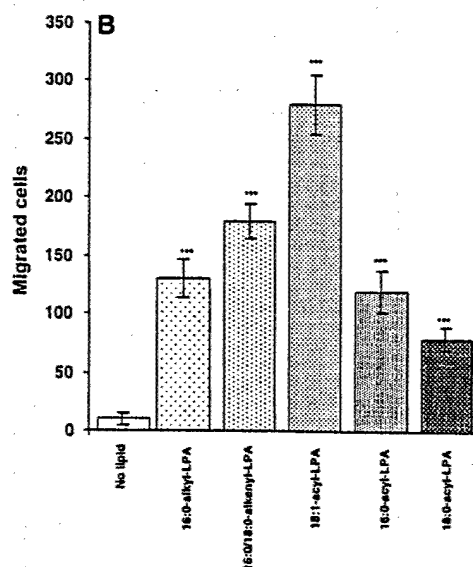
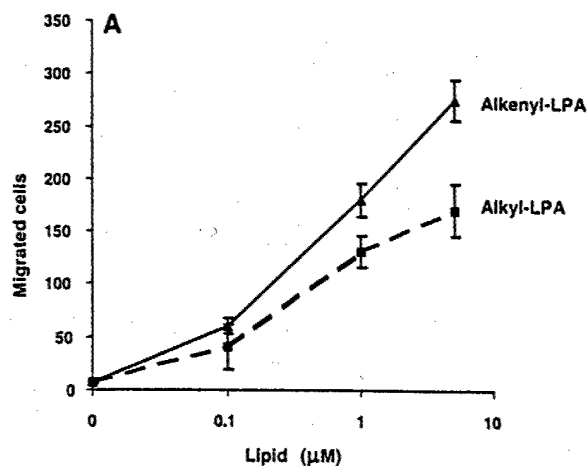

Fig. 7. Al-LPA stimulated HEY cell migration. A: Cell mobility was measured in a modified Boyden chamber assay as described in Materials and Methods. Alkyl- or alkenyl-LPA (0–5 μM) was added to the lower chamber. Cells migrated to the lower phase of the mem-

TABLE 2. Checkerboard analysis of HEY cells^a

	Alkyl-PLA, Upper Chamber			
	0	0.1	1	5
μM				
Alkyl-LPA, lower chamber (μM)				
0	68 ± 5	72 ± 13	65 ± 13	55 ± 13
0.1	280 ± 50	167 ± 29	88 ± 10	77 ± 15
1	408 ± 36	367 ± 15	210 ± 30	87 ± 12
5	659 ± 12	587 ± 55	343 ± 21	120 ± 12
Alkenyl-LPA, lower chamber (μM)				
0	78 ± 13	77 ± 8	67 ± 6	82 ± 8
0.1	230 ± 26	150 ± 26	118 ± 28	118 ± 28
1	493 ± 51	293 ± 40	207 ± 15	132 ± 28
5	827 ± 122	550 ± 30	270 ± 72	112 ± 38

^a Different concentrations of alkyl-LPA or alkenyl-LPA were added to the upper and/or lower chamber, and HEY cells in the upper chamber were allowed to migrate for 4 h at 37°C.

tives have been tested for their anti-proliferative activities (58). Together with the observations present here, these data suggest that a free phosphate group at the sn-3 position is important for the mitogenic activity of lysolipid(s).

Acyl-LPAs containing unsaturated fatty acids, such as 18:1- and 18:2-acyl-LPAs, are more potent in stimulation of growth (20), IL-8 secretion, and cell migration. These data suggest that 18:1- and 18:2-acyl-LPAs, which compose approximately 17% (Table 1) of total acyl-LPAs in ascites (20, 35) and al-LPAs, which compose approximately 12% of all LPA species, may account for the major portion of biological activities of LPAs in ovarian cancer ascites. The pathophysiological importance of al-LPAs is further supported by our observation that these LPA species are more stable than acyl-LPAs at 4°C (Fig. 1). The instability of LPAs at 4°C may reflect LPA-degrading reactions by endogenous enzymes (at a slower reaction when compared with physiological conditions at 37°C). However, since the ascites samples were stored under sterile conditions, exogenous LPA-degrading enzymes from bacteria and/or other sources were unlikely. The two major pathways to degrade LPA are deacylation by lyso-phospholipase A₁ (PLA₁) and dephosphorylation by phosphatases (LPPs) (59, 60). Though dephosphorylation of al-LPAs and acyl-

brane were counted after starved cells were seeded in the upper chamber for 4 h. B: The relative potencies of different LPA species in stimulating cell migration. Different LPA species (1 μM) were added to the lower chamber of the migration chamber, and starved cells were added to the upper chamber. Migration was allowed for 4 h at 37°C. C: Al-LPA-stimulated migration was PTX- and Rho-sensitive and PI3K-dependent. HEY cells were pretreated with PTX (100 ng/ml) for 16 h, or transiently transfected with C3-exoenzyme (C3, a Rho inhibitor), or dominant negative MEK (MEK/2A). HEY cells in the absence (control) or presence of LY294002 (10 μM, LY), as well as PTX pretreated cells or transfected cells, were loaded into the upper chambers and the lipids (1 μM) were added to the lower chamber. The migration was conducted for 4 h. The cell number on the lower face of the membrane was counted. The results are presented as the mean ± SD of three independent experiments. *** *P* < 0.001 (Student's *t*-test).

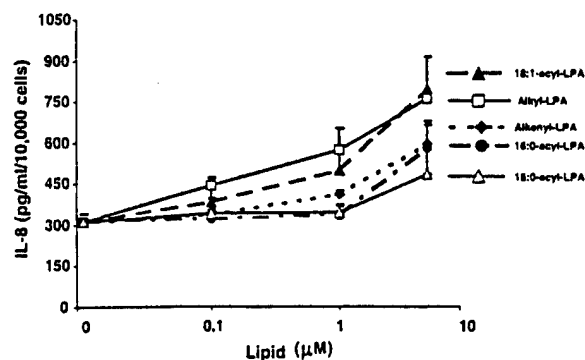

Fig. 8. Stimulation of IL-8 secretion by LPAs in HEY cells. Cells were starved from serum for 18–24 h and treated for 6 h with varying doses of LPAs. The supernatants were then removed and stored in a freezer at -80°C until ELISA (Materials and Methods) was performed.

LPAs by LPPs may be similarly effective, ether-linked al-LPAs are not degradable by PLA₁, which may account for the relatively higher stability of al-LPAs.

We show here that different biological effects induced by al-LPAs require different signaling pathways. PI3K activity is required for cell proliferation, cell migration, and Akt activation/phosphorylation. MEK is required for cell proliferation and S473 phosphorylation of Akt, but not for cell migration. S473 phosphorylation of Akt, but not cell proliferation, is dependent on p38 MAP kinase activity. These data suggest that MEK activation can lead to a p38-dependent Akt phosphorylation, and a p38-independent stimulation of DNA synthesis. These signaling properties provide important information on strategies to antagonize the cellular effects of al-LPAs. Interestingly, we have found that S473, but not T308, phosphorylation induced by al-LPAs is sensitive to SB 203580, suggesting that p38 MAP kinase is required for S473, but not T308, phosphorylation. The involvement of p38 in Akt phosphorylation and activation has been reported in a few recent works (38, 39, 61). In fibroblasts, phosphorylation at both Akt S473 and T308 induced by formyl-methionyl-leucyl-phenylalanine is sensitive to SB 203580, and S473 phosphorylation is more sensitive than T308 to SB 203580. In mouse epidermal J6 cells, UVB-induced T308 phosphorylation is more sensitive than S473 to SB 203580. Together, these and our results suggest that the dependence of T308 phosphorylation on p38 is likely to be stimulus- or cell type-specific.

The work here shows that al-LPAs appear to stimulate the same or similar signaling pathways as acyl-LPAs, although they differ in concentration and time point for optimal stimulations. In particular, we have shown recently that acyl-LPA stimulated a rather unique Rho- and MEK-dependent Akt phosphorylation. This signaling pathway is not shared by many other stimuli that we have tested, including SIP, thrombin, endothelin-1, PDGF, insulin, and EGF (unpublished observations). These data suggest that the effects of al-LPAs may be mediated by acyl-LPA receptors (Edg receptors). In fact, both Edg4 and Edg7 have

been shown to respond to alkyl- and/or alkenyl-LPAs (62–64). We have found that HEY cells express Edg2 and 7, and SKOV3 cells express Edg2, 4, and 7 (unpublished observations). Since subtype-selective receptor antagonists are not yet available, the direct assignment of the endogenous receptors mediating the effects induced by al-LPAs in HEY cells remains to be determined. ■

This work is supported in part by American Cancer Society Grant RPG-99-062-01-CNE, US Army Medical Research grant DAMD17-99-1-9563, and NIH grant R21 CA84038-01 (to Y.X.)

Manuscript received 14 September 2001 and in revised form 2 January 2002.

REFERENCES

- Moolenaar, W. H. 1999. Bioactive lysophospholipids and their G protein-coupled receptors. *Exp. Cell Res.* 253: 230–238.
- Moolenaar, W. H., O. Kranenburg, F. R. Postma, and G. C. Zondag. 1977. Lysophosphatidic acid: G-protein signalling and cellular responses. *Curr. Opin. Cell Biol.* 9: 168–173.
- Liscovitch, M., and L. C. Cantley. 1994. Lipid second messengers. *Cell* 77: 329–334.
- Xu, Y., Y. Xiao, L. M. Baudhuin, and B. M. Schwartz. 2001. The role and clinical applications of bioactive lysolipids in ovarian cancer. *J. Soc. Gyn. Invest.* 8: 1–13.
- Nugent, D., J. Belinson, and Y. Xu. 1999. The synergistic interactions of oleoyl-lysophosphatidic acid in platelet aggregation. *Med. Sci. Res.* 27: 435–441.
- An, S., E. J. Goetzl, and H. Lee. 1998. Signaling mechanisms and molecular characteristics of G protein-coupled receptors for lysophosphatidic acid and sphingosine 1-phosphate. *J. Cell. Biochem. Suppl.* 31: 147–157.
- Contos, J. J., I. Ishii, and J. Chun. 2000. Lysophosphatidic acid receptors. *Mol. Pharmacol.* 58: 1188–1196.
- Eichholtz, T., K. Jalink, I. Fahrenfort, and W. H. Moolenaar. 1993. The bioactive phospholipid lysophosphatidic acid is released from activated platelets. *Biochem. J.* 291: 677–680.
- Palmethofer, A., S. C. Robson, and V. Nehls. 1999. Lysophosphatidic acid activates nuclear factor kappa B and induces proinflammatory gene expression in endothelial cells. *Thromb. Haemost.* 82: 1532–1537.
- Weinstein, J. R., A. L. Lau, L. F. Brass, and D. D. Cunningham. 1998. Injury-related factors and conditions down-regulate the thrombin receptor (PAR-1) in a human neuronal cell line. *J. Neurochem.* 71: 1034–1050.
- Lee, H., E. J. Goetzl, and S. An. 2000. Lysophosphatidic acid and sphingosine 1-phosphate stimulate endothelial cell wound healing. *Am. J. Physiol. Cell Physiol.* 278: C612–618.
- Liliom, K., Z. Guan, J. L. Tseng, D. M. Desiderio, G. Tigyi, and M. A. Watsky. 1998. Growth factor-like phospholipids generated after corneal injury. *Am. J. Physiol.* 274: C1065–1074.
- Sullivan, L. M., C. W. Honemann, J. A. Arledge, and M. E. Durieux. 1999. Synergistic inhibition of lysophosphatidic acid signaling by charged and uncharged local anesthetics. *Anesth. Analg.* 88: 1117–1124.
- Watsky, M. A., M. Griffith, D. A. Wang, and G. J. Tigyi. 2000. Phospholipid growth factors and corneal wound healing. *Ann. N.Y. Acad. Sci.* 905: 142–158.
- Hu, Y. L., M. K. Tee, E. J. Goetzl, N. Auersperg, G. B. Mills, N. Ferrara, and R. B. Jaffe. 2001. Lysophosphatidic acid induction of vascular endothelial growth factor expression in human ovarian cancer cells. *J. Natl. Cancer Inst.* 93: 762–767.
- Goetzl, E. J., and S. An. 1998. Diversity of cellular receptors and functions for the lysophospholipid growth factors lysophosphatidic acid and sphingosine 1-phosphate. *FASEB J.* 12: 1589–1598.
- An, S., T. Bleu, O. G. Hallmark, and E. J. Goetzl. 1998. Characterization of a novel subtype of human G protein-coupled receptor for lysophosphatidic acid. *J. Biol. Chem.* 273: 7906–7910.
- Lynch, K. R., and I. Im. 1999. Life on the edg. *Trends Pharmacol. Sci.* 20: 473–475.
- Moolenaar, W. H. 1999. Bioactive lysophospholipids and their G protein-coupled receptors. *Exp. Cell Res.* 253: 230–238.

20. Xu, Y., D. Gaudette, J. Boynton, A. Frankel, X. Fang, A. Sharma, J. Hurteau, G. Casey, A. Goodbody, A. Mellors, B. J. Holub, and G. B. Mills. 1995. Characterization of an ovarian cancer activating factor in ascites from ovarian cancer patients. *Clin. Cancer Res.* 1: 1223-1232.
21. Xu, Y., X. Fang, G. Casey, and G. Mills. 1995. Lysophospholipids activate ovarian and breast cancer cells. *Biochem. J.* 309: 933-940.
22. Xu, Y., G. Casey, and G. Mills. 1995. Effect of lysophospholipids on signaling in the human Jurkat T cell line. *J. Cell. Physiol.* 163: 441-450.
23. Hong, C., L. M. Baudhuin, and Y. Xu. 1999. Sphingosine-1-phosphate modulates growth and adhesion of ovarian cancer cells. *FEBS Lett.* 460: 513-518.
24. Schwartz, B. M., C. Hong, B. H. Morrison, W. Wu, L. M. Baudhuin, Y. J. Xiao, S. C. Mok, and Y. Xu. 2001. Lysophospholipids increase interleukin-8 expression in ovarian cancer cells. *Gynecol. Oncol.* 81: 291-300.
25. Frankel, A., and G. B. Mills. 1996. Peptide and lipid growth factors decrease cis-diamminedichloroplatinum-induced cell death in human ovarian cancer cells. *Clin. Cancer Res.* 2: 1307-1313.
26. Fang, X., S. Yu, R. Lapushin, Y. Lu, T. Furui, L. Z. Penn, D. Stokoe, J. R. Erickson, R. C. Bast, Jr., and G. B. Mills. 2000. Lysophosphatidic acid prevents apoptosis in fibroblasts via Gi-protein-mediated activation of mitogen-activated protein kinase. *Biochem. J.* 352: 135-143.
27. Pustilnik, T. B., V. Estrella, J. R. Wiener, M. Mao, A. Eder, M. A. Watt, R. C. Bast, Jr., and G. B. Mills. 1999. Lysophosphatidic acid induces urokinase secretion by ovarian cancer cells. *Clin. Cancer Res.* 5: 3704-3710.
28. Xu, Y., Z. Shen, D. Wiper, M. Wu, R. Morton, P. Elson, A. Kennedy, J. Belinson, M. Markman, and G. Casey. 1998. Lysophosphatidic acid as a potential biomarker for ovarian and other gynecologic cancers. *JAMA.* 280: 719-723.
29. Moolenaar, W. H. 1995. Lysophosphatidic acid signalling. *Curr. Opin. Cell Biol.* 7: 203-210.
30. Simon, M. F., H. Chap, and L. Douste-Blazy. 1982. Human platelet aggregation induced by 1-alkyl-lysophosphatidic acid and its analogs: a new group of phospholipid mediators? *Biochem. Biophys. Res. Commun.* 108: 1743-1750.
31. Svetlov, S. I., A. Siafaka-Kapadai, D. J. Hanahan, and M. S. Olson. 1996. Signaling responses to alkyllysophosphatidic acid: the activation of phospholipases A2 and C and protein tyrosine phosphorylation in human platelets. *Arch. Biochem. Biophys.* 336: 59-68.
32. Liliom, K., D. J. Fischer, T. Virag, G. Sun, D. D. Miller, J. L. Tseng, D. M. Desiderio, M. C. Seidel, J. R. Erickson, and G. Tigy. 1998. Identification of a novel growth factor-like lipid, 1-O-cis-alk-1'-enyl-2-lyso-sn-glycerol-3-phosphate (alkenyl-GP) that is present in commercial sphingolipid preparations. *J. Biol. Chem.* 273: 13461-13468.
33. Fischer, D. J., K. Liliom, Z. Guo, N. Nusser, T. Virag, K. Murakami-Murofushi, S. Kobayashi, J. R. Erickson, G. Sun, D. D. Miller, and G. Tigy. 1998. Naturally occurring analogs of lysophosphatidic acid elicit different cellular responses through selective activation of multiple receptor subtypes. *Mol. Pharmacol.* 54: 979-988.
34. Sugiura, T., S. Nakane, S. Kishimoto, K. Waku, Y. Yoshioka, A. Tokumura, and D. J. Hanahan. 1999. Occurrence of lysophosphatidic acid and its alkyl ether-linked analog in rat brain and comparison of their biological activities toward cultured neural cells. *Biochim. Biophys. Acta.* 1440: 194-204.
35. Xiao, Y. J., B. Schwartz, M. Washington, A. Kennedy, K. Webster, J. Belinson, and Y. Xu. 2001. Electrospray ionization mass spectrometry analysis of lysophospholipids in human ascitic fluids: comparison of the lysophospholipid contents in malignant vs nonmalignant ascitic fluids. *Anal. Biochem.* 290: 302-313.
36. Xiao, Y., Y. Chen, A. W. Kennedy, J. Belinson, and Y. Xu. 2000. Evaluation of plasma lysophospholipids for diagnostic significance using electrospray ionization mass spectrometry (ESI-MS) analyses. *Ann. N.Y. Acad. Sci.* 905: 242-259.
37. Okamoto, H., Y. Yatomi, T. Ohmori, K. Satoh, Y. Matsumoto, and Y. Ozaki. 2000. Sphingosine 1-phosphate stimulates G(i)- and rho-mediated vascular endothelial cell spreading and migration. *Thromb. Res.* 99: 259-265.
38. Nomura, M., A. Kaji, W. Y. Ma, S. Shong, G. Liu, G. T. Bowden, K. Miyamoto, and Z. Dong. 2001. Mitogen- and stress-activated protein kinase-1 mediates activation of Akt by ultraviolet B irradiation. *J. Biol. Chem.* 276: 25558-25567.
39. Hsu, E. H., A. C. Lochan, and D. S. Cowen. 2001. Activation of akt by human 5-hydroxytryptamine (serotonin)(1b) receptors is sensitive to inhibitors of mek. *J. Pharmacol. Exp. Ther.* 298: 825-832.
40. Pietruck, F., S. Busch, S. Virchow, N. Brockmeyer, and W. Siffert. 1997. Signalling properties of lysophosphatidic acid in primary human skin fibroblasts: role of pertussis toxin-sensitive GTP-binding proteins. *Naunyn-Schmiedeberg's Arch. Pharmacol.* 355: 1-7.
41. Sakai, T., J. M. de la Pena, and D. F. Mosher. 1999. Synergism among lysophosphatidic acid, beta1A integrins, and epidermal growth factor or platelet-derived growth factor in mediation of cell migration. *J. Biol. Chem.* 274: 15480-15486.
42. Panetti, T. S., J. Nowlen, and D. F. Mosher. 2000. Sphingosine-1-phosphate and lysophosphatidic acid stimulate endothelial cell migration. *Arterioscler. Thromb. Vasc. Biol.* 20: 1013-1019.
43. Nobes, C. D., and A. Hall. 1999. Rho GTPases control polarity, protrusion, and adhesion during cell movement. *J. Cell Biol.* 144: 1235-1244.
44. Imamura, F., M. Mukai, M. Ayaki, K. Takemura, T. Horai, K. Shin-kai, H. Nakamura, and H. Akedo. 1999. Involvement of small GTPases Rho and Rac in the invasion of rat ascites hepatoma cells. *Clin. Exp. Metastasis.* 17: 141-148.
45. Zhou, D., W. Luini, S. Bernasconi, L. Diomedea, M. Salmona, A. Mantovani, and S. Sozzani. 1995. Phosphatidic acid and lysophosphatidic acid induce haptotactic migration of human monocytes. *J. Biol. Chem.* 270: 25549-25556.
46. Stam, J. C., F. Michiels, R. A. van der Kammen, W. H. Moolenaar, and J. G. Collard. 1998. Invasion of T-lymphoma cells: cooperation between Rho family GTPases and lysophospholipid receptor signaling. *EMBO J.* 17: 4066-4074.
47. Anand-Apte, B., B. R. Zetter, A. Viswanathan, R. G. Qiu, J. Chen, R. Ruggieri, and M. Symons. 1997. Platelet-derived growth factor and fibronectin-stimulated migration are differentially regulated by the Rac and extracellular signal-regulated kinase pathways. *J. Biol. Chem.* 272: 30688-30692.
48. Kundra, V., B. Anand-Apte, L. A. Feig, and B. R. Zetter. 1995. The chemotactic response to PDGF-BB: evidence of a role for Ras. *J. Cell Biol.* 130: 725-731.
49. Moser, T. L., S. V. Pizzo, L. M. Bafetti, D. A. Fishman, and M. S. Stack. 1996. Evidence for preferential adhesion of ovarian epithelial carcinoma cells to type I collagen mediated by the alpha2beta1 integrin. *Int. J. Cancer.* 67: 695-701.
50. Harada, A., N. Mukaida, and K. Matsushima. 1996. Interleukin 8 as a novel target for intervention therapy in acute inflammatory diseases. *Mol. Med. Today.* 2: 482-489.
51. Koch, A. E., P. J. Polverini, S. L. Kunkel, L. A. Harlow, L. A. DiPietro, V. M. Elner, S. G. Elner, and R. M. Strieter. 1992. Interleukin-8 as a macrophage-derived mediator of angiogenesis. *Science.* 258: 1798-1801.
52. Folkman, J. 1993. Diagnostic and therapeutic applications of angiogenesis research. *C. R. Acad. Sci. III.* 316: 909-918.
53. Merogi, A. J., A. J. Marrogi, R. Ramesh, W. R. Robinson, C. D. Fermin, and S. M. Freeman. 1997. Tumor-host interaction: analysis of cytokines, growth factors, and tumor-infiltrating lymphocytes in ovarian carcinomas. *Hum. Pathol.* 28: 321-331.
54. Yoneda, J., H. Kuniyasu, M. A. Crispens, J. E. Price, C. D. Bucana, and I. J. Fidler. 1998. Expression of angiogenesis-related genes and progression of human ovarian carcinomas in nude mice. *J. Natl. Cancer Inst.* 90: 447-454.
55. Gawrychowski, K., E. Skopinska-Rozewska, E. Barcz, E. Sommer, B. Szaniawska, K. Roszkowska-Purska, P. Janik, and J. Zielinski. 1998. Angiogenic activity and interleukin-8 content of human ovarian cancer ascites. *Eur. J. Gynaecol. Oncol.* 19: 262-264.
56. Ivarsson, K., E. Runesson, K. Sundfeldt, M. Haeger, L. Hedin, P. O. Janson, and M. Brannstrom. 1998. The chemotactic cytokine interleukin-8—a cyst fluid marker for malignant epithelial ovarian cancer? *Gynecol. Oncol.* 71: 420-423.
57. Goto, I., M. Hozumi, and Y. Honma. 1994. Selective effect of O-alkyl lysophospholipids on the growth of a human lung giant cell carcinoma cell line. *Anticancer Res.* 14: 357-362.
58. Ashagbley, A., P. Samadder, R. Bittman, R. K. Erukulla, H. S. Byun, and G. Arthur. 1996. Synthesis of ether-linked analogues of lysophosphatidic acid and their effect on the proliferation of human epithelial cancer cells in vitro. *Anticancer Res.* 16: 1813-1818.
59. Dillon, D. A., X. Chen, G. M. Zeimet, W. I. Wu, D. W. Waggoner, J. Dewald, D. N. Brindley, and G. M. Carman. 1997. Mammalian Mg2+-independent phosphatidate phosphatase (PAP2) displays diacylglycerol pyrophosphate phosphatase activity. *J. Biol. Chem.* 272: 10361-10366.

60. Pilquill, C., I. Singh, Q. Zhang, Z. Ling, K. Buri, L. M. Stromberg, J. Dewald, and D. N. Brindley. 2001. Lipid phosphate phosphatase-1 dephosphorylates exogenous lysophosphatidate and thereby attenuates its effects on cell signalling. *Prostaglandins*. 64: 83-92.
61. Rane, M. J., P. Y. Coxon, D. W. Powell, R. Webster, J. B. Klein, W. Pierce, P. Ping, and K. R. McLeish. 2001. p38 Kinase-dependent MAPKAPK-2 activation functions as 3-phosphoinositide-dependent kinase-2 for akt in human neutrophils. *J. Biol. Chem.* 276: 3517-3523.
62. Aoki, J., K. Bandoh, and K. Inoue. 2000. A novel human G-protein-coupled receptor, EDG7, for lysophosphatidic acid with unsaturated fatty-acid moiety. *Ann. N.Y. Acad. Sci.* 905: 263-266.
63. Bandoh, K., J. Aoki, H. Hosono, S. Kobayashi, T. Kobayashi, K. Murakami-Murofushi, M. Tsujimoto, H. Arai, and K. Inoue. 1999. Molecular cloning and characterization of a novel human G-protein-coupled receptor, EDG7, for lysophosphatidic acid. *J. Biol. Chem.* 274: 27776-27785.
64. An, S., T. Bleu, Y. Zheng, and E. J. Goetzl. 1998. Recombinant human G protein-coupled lysophosphatidic acid receptors mediate intracellular calcium mobilization. *Mol. Pharmacol.* 54: 881-888.

Sphingosylphosphorylcholine and Lysophosphatidylcholine Are Ligands for the G Protein-coupled Receptor GPR4*

Received for publication, September 4, 2000, and in revised form, August 29, 2001
Published, JBC Papers in Press, September 4, 2001, DOI 10.1074/jbc.M008057200

Kui Zhu[‡], Linnea M. Baudhuin^{‡§}, Guiying Hong[‡], Freager S. Williams[¶], Kelly L. Cristina[‡],
Janusz H. S. Kabarowski^{¶*}, Owen N. Witte^{||}, and Yan Xu^{¶†‡‡}

From the [‡]Department of Cancer Biology and the [¶]Department of Gynecology and Obstetrics, Cleveland Clinic Foundation, Cleveland, Ohio 44195, the [§]Department of Chemistry, Cleveland State University, Cleveland, Ohio 44115, and the ^{||}Department of Microbiology, Immunology and Molecular Genetics, Howard Hughes Medical Institute, University of California, Los Angeles, California 90095-1662

Sphingosylphosphorylcholine (SPC) and lysophosphatidylcholine (LPC) are bioactive lipid molecules involved in numerous biological processes. We have recently identified ovarian cancer G protein-coupled receptor 1 (OGR1) as a specific and high affinity receptor for SPC, and G2A as a receptor with high affinity for LPC, but low affinity for SPC. Among G protein-coupled receptors, GPR4 shares highest sequence homology with OGR1 (51%). In this work, we have identified GPR4 as not only another high affinity receptor for SPC, but also a receptor for LPC, albeit of lower affinity. Both SPC and LPC induce increases in intracellular calcium concentration in GPR4, but not vector-transfected MCF10A cells. These effects are insensitive to treatment with BN52021, WEB-2170, and WEB-2086 (specific platelet activating factor (PAF) receptor antagonists), suggesting that they are not mediated through an endogenous PAF receptor. SPC and LPC bind to GPR4 in GPR4-transfected CHO cells with K_d /SPC = 36 nM, and K_d /LPC = 159 nM, respectively. Competitive binding is elicited only by SPC and LPC. Both SPC and LPC activate GPR4-dependent activation of serum response element reporter and receptor internalization. Swiss 3T3 cells expressing GPR4 respond to both SPC and LPC, but not sphingosine 1-phosphate (S1P), PAF, psychosine (Psy), glucosyl- β 1'-sphingosine (Glu-Sph), galactosyl- β 1'-ceramide (Gal-Cer), or lactosyl- β 1'-ceramide (Lac-Cer) to activate extracellular signal-regulated kinase mitogen-activated protein kinase in a concentration- and time-dependent manner. SPC and LPC stimulate DNA synthesis in GPR4-expressing Swiss 3T3 cells. Both extracellular signal-regulated kinase activation and DNA synthesis stimulated by SPC and LPC are pertussis toxin-sensitive, suggesting the involvement of a G_i -heterotrimeric G protein. In addition, GPR4 expression confers chemotactic responses to both SPC and LPC in Swiss 3T3 cells. Taken together, our data indicate that GPR4 is a receptor with high affinity to SPC and low affinity to LPC, and that multiple cellular functions can be transduced via this receptor.

SPC¹ is a bioactive lipid molecule involved in numerous biological processes, where it acts as a signaling molecule (1). We have recently identified a G protein-coupled receptor, OGR1, as the first specific high affinity receptor for SPC (2). OGR1 shares homology with several other G protein-coupled receptors, including GPR4, G2A, T cell death-associated G protein-coupled receptor 8 (TDAG8), and the platelet activating factor (PAF) receptor (3–8, 10). We have postulated that these receptors belong to a subfamily and their ligands may be lysolipids containing the phosphorylcholine moiety shared by SPC and PAF (2). Other than SPC and PAF, there are two naturally occurring phosphorylcholine-containing lysolipids: LPC and lyso-PAF. LPC is an important lipid mediator involved in many cellular processes. In particular, LPC is believed to play an important role in atherosclerosis and inflammatory diseases by altering various functions of a variety of cell types, including endothelial cells, smooth muscle cells, monocytes, macrophages, and T cells (11–13). However, the reported signaling mechanisms of LPC are variable and the initial interaction of LPC with cell membranes is poorly understood. We have recently identified G2A as the first receptor for LPC (14). G2A is also a low affinity receptor for SPC.

In the present study, we sought to identify the ligand(s) for GPR4. We tested SPC, LPC, PAF, lyso-PAF, and psychosine (Psy; a recently identified glycosphingolipid ligand of TDAG8 (15)) as potential ligands for GPR4. GPR4 exhibits the highest homology with OGR1 (51% identity and 64% similarity in amino acid sequence) (2). Similarly to OGR1, GPR4 responded to SPC, but also responded to LPC, mediating an increase in intracellular calcium concentration, SRE activation, receptor internalization, ERK activation, and stimulation of cell migration. LPC bound to GPR4, albeit with lower affinity compared with SPC, and competed with SPC for specific binding to GPR4. GPR4 did not bind or respond to PAF, lyso-PAF, Psy, Glu-Sph, Gal-Cer, or Lac-Cer. Our results indicate that SPC is a high affinity and LPC is a lower affinity ligand for GPR4, and its activation by SPC and LPC mediates biological functions.

¹ The abbreviations used are: SPC, sphingosylphosphorylcholine; ERK, extracellular signal-regulated kinase; CHO, Chinese hamster ovary; Glu-Sph, glucosyl- β 1'-sphingosine; Gal-Cer, galactosyl- β 1'-ceramide; Lac-Cer, lactosyl- β 1'-ceramide; LPA, lysophosphatidic acid; LPC, lysophosphatidylcholine; OGR1, ovarian cancer G protein-coupled receptor 1; PAF, platelet activating factor; Psy, psychosine; S1P, sphingosine 1-phosphate; SRE, serum response element; TDAG8, T cell death-associated gene 8; FBS, fetal bovine serum; DMEM, Dulbecco's modified Eagle's medium; GAPDH, glyceraldehyde-3-phosphate dehydrogenase; PTX, pertussis toxin; PBS, phosphate-buffered saline; PCR, polymerase chain reaction; HA, hemagglutinin; GFP, green fluorescent protein; BSA, bovine serum albumin; MAP, mitogen-activated protein; $[Ca^{2+}]_i$, intracellular calcium.

* This work was supported in part by American Cancer Society Grant RPG-99-062-01-CNE, United States Army Grant DAMD 17-99-1-9563, and National Institutes of Health Grants R21 CA84038-01 (to Y. X.) and Grant CA76204 (to O. N. W.). The costs of publication of this article were defrayed in part by the payment of page charges. This article must therefore be hereby marked "advertisement" in accordance with 18 U.S.C. Section 1734 solely to indicate this fact.

** Fellow of the Leukemia and Lymphoma Society of America.

†† To whom correspondence should be addressed. Tel.: 216-444-1168; Fax: 216-445-6269; E-mail: xuy@ccf.org xuy@ccf.org.

EXPERIMENTAL PROCEDURES

Materials—LPCs (14:0, 16:0, 18:0, and 18:1), lysophosphatidylinositol (from liver, 80% 18:0), 18:1-LPA, 16:0-PAF, 16:0-lyso-PAF, psychosine, glucosyl- β 1'-sphingosine, galactosyl-1'-C8-ceramide, and lactosyl- β 1'-C8-ceramide were from Avanti Polar Lipids, Inc. (Alabaster, AL). Sphingomyelin (bovine brain, mainly 18:0), C6-ceramide, sphingosine 1-phosphate (S1P), and SPC were from Toronto Research Chemicals (Toronto, ON) or Matreya, Inc. (Pleasant Gap, PA). D-Erythro- and L-threo-SPC were from Matreya, Inc. (Pleasant Gap, PA). pcDNA1-C3 (encoding the C3-exoenzyme) was a kind gift from Dr. A. Wolfman, Cleveland Clinic Foundation. The PAF receptor antagonist, BN52021, was from Biomol (Plymouth Meeting, PA). WEB-2170 and WEB-2086 were from Boehringer Ingelheim (Ridgefield, CT). [3 H]SPC or [3 H]18:0-LPC were custom synthesized by Amersham Pharmacia Biotech, Buckinghamshire, United Kingdom (68 Ci/mmol, 1 mCi/ml for [3 H]SPC and 102 Ci/mmol, 1 mCi/ml for [3 H]18:0-LPC). [3 H]16:0-LPC (60 Ci/mmol) was purchased from American Radiolabeled Chemicals, Inc. (St Louis, MO).

Cell Culture—MCF10A cells (passage 34) were purchased from the Barbara Ann Karmanos Cancer Institute (Detroit, MI) and cultured as recommended by the provider. Experiments were performed using MCF10A cells from passage 40–46. Other cells were obtained from ATCC and were cultured either in RPMI 1640 with 10% FBS or DMEM with 5% FBS (CHO and Swiss 3T3 cells).

Human RNA Master Blot Probed with GPR4—Human RNA Master Blot (CLONTECH, Palo Alto, CA) was probed with radiolabeled full-length GPR4. Briefly, the full-length GPR4 was gel purified and 25 ng was used for the synthesis of a StripAble DNA α - 32 P-labeled probe (Ambion, Austin, TX), as per the manufacturer's instructions. The radiolabeled probe (20 ng, 20×10^6 cpm) was hybridized to the Master Blot in ExpressHyb hybridization solution (CLONTECH) overnight with continuous agitation at 65 °C. The following day, the Master Blot was washed following the manufacturer's instructions and exposed to a PhosphoScreen (Molecular Dynamics, Sunnyvale, CA).

Real-time Quantitative PCR of GPR4—Total RNA was extracted from cells using the SV Total RNA Isolation System (Promega, Madison, WI). One to 5 μ g of total RNA were reverse transcribed using Superscript II RT (Life Technologies, Inc., Rockville, MD). Eight nanograms of derived cDNA were used as a template for real-time quantitative SYBR Green I PCR. Primers for human GPR4 (GenBank™ accession number U21051) were 5'-TAATGCTAGCGGCAACACACG-TGGGAG and 5'-TCCAGTTGCTGCTGGTGCAG, yielding a 230-base pair product. Glyceraldehyde-3-phosphate dehydrogenase (GAPDH) was amplified in a separate tube as a housekeeping gene with primers 5'-GAAGGTGAAGTCCGAGT and 5'-GAAGATGGTGTGGGATTTTC, yielding a 226-base pair product. Primers for mouse GPR4 were 5'-CTACCTGGCTGTGGCTCAT and 5'-CAAAGACGCGGTATAGATTCA, yielding a 222-base pair product. Mouse GAPDH was amplified with primers 5'-TGATGGGTGGAACCAAGACA and 5'-CCAGTGGATCA-GGGATGAT. All SYBR Green I core reagents, including AmpliTaq Gold DNA polymerase, were from PE Applied Biosystems (Foster City, CA). The thermal cycling conditions were 95 °C for 10 min, followed by 40 cycles of 95 °C, 15 s, and 60 °C, 1 min. PCR reactions and product detection were carried out in an ABI Prism 7700 Sequence Detection System (PE Applied Biosystems). The amplified product was detected by measurement of SYBR Green I, which was added to the initial reaction mixture. The threshold cycle (C_T) values obtained through the experiments indicate the fractional cycle numbers at which the amount of amplified target reach a fixed threshold. The C_T values of both target and internal reference (GAPDH) were measured from the same samples, and the expression of the target gene relative to that of GAPDH was calculated using the comparative C_T method. This method normalizes the expression levels and allows calculation of the relative efficiency of the target and reference amplification.

Cloning—A GPR4 PCR fragment (nucleotides number 1175–1535) (4) was obtained by PCR amplification using cDNA from HEY ovarian cancer cells as the template. This PCR fragment was used to screen a human genomic library (CLONTECH, Palo Alto, CA) to obtain the full-length clone of GPR4. GPR4 was subsequently cloned into mammalian expression vectors using PCR amplifications with the high fidelity Advantage cDNA polymerase (CLONTECH). The PCR reactions were conducted for fewer than 20 cycles and the sequence of the products was confirmed by sequencing. The primers, 5'-CAGGAAT-TCTCGGCAACACACGTTGGGAGG and 5'-CGCTCTAGACCACTC-GGGGTTTCATGTG, were used to generate full-length GPR4, which was digested with *Eco*RI and *Xba*I and cloned into the pBS3HA vector (pBluescript II KS⁺ vector with three HA tags inserted; a kind gift from

Dr. J. DiDonato, Cleveland Clinic Foundation). The resulting 3HA-GPR4 was subsequently cloned into the mammalian expression vector pIRES-hygro (CLONTECH) to generate pIRESHyg-GPR4, using primer 5'-CAGATGCATAAACGCTCAACTTTGG and the T7 primer (inserted into the *Nsi*I and *Not*I sites of pIRES-hygro). pGPR4-GFP was generated using the T3 primer and 5'-GTCCGTACCTGTGCTGGCGGCAGC-ATC (stop codon was deleted and the resulting GPR4 was cloned into *Hind*III and *Kpn*I sites of pEGFP-N1; CLONTECH). pSRE-Luc was purchased from Stratagene (La Jolla, CA). MCF10A cells were transiently transfected with pGPR4-GFP and used for calcium assays. CHO cells were transfected with pIRESHyg-GPR4 (LipofectAMINE reagent; Life Technologies, Rockville, MD) and stable clones were selected with 200 μ g/ml hygromycin in DMEM/F-12 plus 5% FBS. HEK293 cells were transfected with pGPR4-GFP and stable clones were selected with 400 μ g/ml G418 in RPMI 1640 plus 10% FBS. Swiss 3T3 cells expressing GPR4 were derived by infection with retroviruses encoding receptor (MSCV GPR4 ires-GFP) followed by fluorescence-activated cell sorter sorting of GFP positive cells (16).

Calcium Assays—Measurement of $[Ca^{2+}]_i$ was performed as described previously (2). Briefly, pGPR4-GFP-transfected MCF10A cells were grown in specialized glass-bottom dishes (Biotech, Inc., Butler, PA) and loaded with fura-2 in HEPES-buffered saline. Using a dual-wavelength spectrofluorometer (RFK-6002, Photon Technology Int., S. Brunswick, NJ) coupled to an inverted fluorescence microscope (Olympus, IX-70, Lake Success, NY), GFP-positive cells were identified using an excitation wavelength of 488 nm, a dichroic 505 nm long-pass filter, and an emitter filter at band pass of 535 nm (Chroma Technology, Brattleboro, VT). Measurements of $[Ca^{2+}]_i$ were performed on individual GPR4-GFP positive cells at excitation wavelengths of 340 and 380 nm and an emission wavelength of 510 nm. Conversion of the 340/380 ratio value into $[Ca^{2+}]_i$ in nanomolar was estimated by comparing the cellular fluorescence ratio with ratios acquired using fura-2 (free acid) in buffers containing known Ca^{2+} concentrations. $[Ca^{2+}]_i$ was then calculated as described by Grynkiewicz *et al.* (17). All calcium assays were performed in the presence of 1 mM EGTA in the assay buffers. Therefore, intracellular calcium release, not calcium influx, was analyzed.

Internalization—pGPR4-GFP stably expressing HEK293 cells were cultured in 6-cm tissue culture dishes in RPMI 1640 with 10% FBS. After 16–24 h serum starvation, cells were treated with different lipids at 37 °C for 2 h. Cells were washed with cold PBS and fixed with 4% paraformaldehyde in PBS. The subcellular localization of GPR4-GFP protein was visualized under a Leica TV confocal fluorescence microscope with a $\times 63$ oil immersion lens (Wetzler, Heidelberg, Germany). The excitation and emission wavelengths were 488 and 515–540 nm, respectively.

Binding Assays—CHO cells were chosen for GPR4 binding assays, because HEK293 cells express relatively high levels of endogenous GPR4. CHO cells stably transfected with empty vector or GPR4 were serum starved for 20 h, then collected after exposure to 2 mM EDTA in PBS. The pelleted cells were stored at –80 °C until use. Binding assays were performed essentially as described previously (2), except binding was performed at 4 °C. Briefly, frozen cells (10^6 cells/ml) were homogenized in a binding buffer (2). Assays were performed in 96-well plates in triplicate with 100 μ l of cell homogenate (equivalent to 10^5 cells/well). Different amounts of [3 H]SPC or [3 H]16:0-LPC were added to the cell homogenates in 50 μ l of binding buffer, in the presence or absence of cold SPC or 16:0-LPC, or other competitors. The plates were incubated at 4 °C for 120 min, unless otherwise indicated. Cell-bound [3 H]SPC or [3 H]LPC was collected onto a filter (Printed Filtermat A, Wallac, Gaithersburg, MD) using an automated cell harvester (HARVESTER 96, Tomtec, Orange, CT). Specific binding was calculated by subtraction of nonspecific binding (binding detected in the presence of 100-fold excess unlabeled SPC or 16:0-LPC) from the total binding.

Reporter (SRE) Assays—The SRE reporter system (pSRE-Luc) was a gift from Dr. Songzhu An (University of California, San Francisco), or purchased from Stratagene (La Jolla, CA). Both systems gave identical results. HEK293 and HEK293-GPR4 cells were cultured in RPMI 1640 with 10% FBS in 10-cm dishes to ~85% confluence. To the cells in each dish, pSRE-Luc (10 μ g) was transfected in the presence of 60 μ l of LipofectAMINE reagent. Cells were seeded in 96-well plates 16 h after transfection, incubated for another 24 h in RPMI 1640 with 10% FBS, and starved in serum-free medium for 16 h. SPC (dissolved in PBS to 10 mM) and other lipids (LPCs were dissolved in 70% ethanol, other lipids dissolved in PBS, 70–95% ethanol or 100% MeOH) were diluted in serum-free RPMI 1640 and added to the cells, followed by a 10-h incubation. Luciferase activity was measured in MicroLite™ 1 plates (Thermo Labsystems, Helsinki, Finland) using 60 μ l of cell lysate and

whole brain	amygdala	caudate nucleus	cerebellum	cerebral cortex	frontal lobe	hippocampus	medulla oblongata
occipital lobe	putamen	substantia nigra	temporal lobe	thalamus	subthalamic nucleus	spinal cord	
heart	aorta	skeletal muscle	colon	bladder	uterus	prostate	stomach
testis	ovary	pancreas	pituitary gland	adrenal gland	thyroid gland	salivary gland	mammary gland
kidney	liver	small intestine	spleen	thymus	peripheral leukocyte	lymph node	bone marrow
appendix	lung	trachea	placenta				
fetal brain	fetal heart	fetal kidney	fetal liver	fetal spleen	fetal thymus	fetal lung	
yeast total RNA 100 ng	yeast tRNA 100 ng	<i>E. coli</i> rRNA 100 ng	<i>E. coli</i> DNA 100 ng	Poly r(A) 100ng	human C11 DNA 100ng	human DNA 100ng	human DNA 500ng

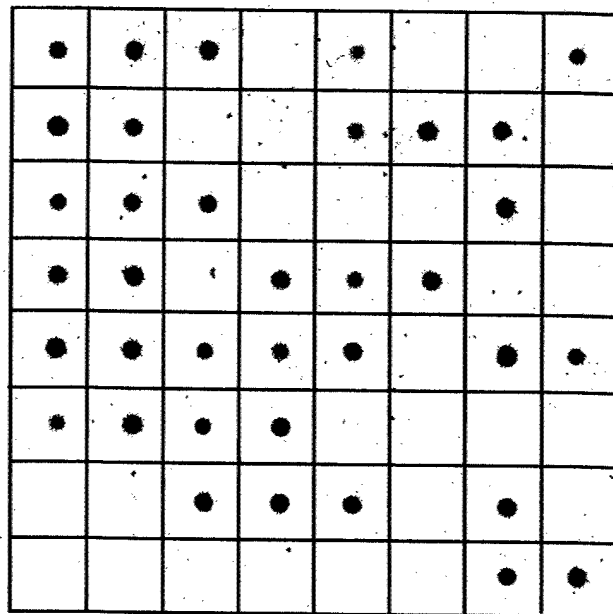

FIG. 1. GPR4 expression in different human tissues. The human RNA Master Blot (CLONTECH) was probed with ^{32}P -labeled GPR4 ("Experimental Procedures").

20 μl of luciferase substrate. PTX (100 ng/ml) was added during the 16-h serum starvation period and pcDNA1-C3 (encoding the C3-exoenzyme, 2 μg) was co-transfected with pSRE-Luc (10 μg).

ERK Activation Assays—Swiss 3T3 cells were infected with MSCV GPR4-ires-GFP or MSCV ires-GFP, and subsequently cells sorted by fluorescence-activated cell sorter for positive expression of GFP as described previously (16). Cells were plated in 6-well plates in DMEM containing 5% FBS, serum-starved overnight, and then treated lipids in DMEM for the indicated times. Cells were lysed on ice in RIPA buffer containing 50 mM Tris-HCl, pH 7.5, 1% Nonidet P-40, 0.5% deoxycholate, 0.1% SDS, 150 mM NaCl, 2 mM EGTA, 25 mM sodium fluoride, 1 mM sodium orthovanadate, and 1 \times protease inhibitors (Sigma P8340). Lysates containing equal amounts of protein were separated on 10% SDS-polyacrylamide gels and transferred onto nitrocellulose membranes. Antibodies against phosphorylated ERK1/2 (Cell Signaling Technologies, Beverly, MA) were used to probe the membrane and the ECL system (Amersham Pharmacia Biotech) was used for detection. To normalize the amounts of protein loaded in each lane, membranes were stripped and re-probed with antibodies against total ERK (Cell Signaling Technologies). In some experiments, cells were pretreated with 100 ng/ml PTX for 12–16 h prior to SPC and LPC stimulation.

DNA Synthesis Assay—The effect of SPC and LPC on DNA synthesis was measured using [^3H]thymidine incorporation. Briefly, GPR4-ires-GFP- and GFP-Swiss 3T3 cells were plated in 96-well plates, serum-starved for 24 h, and treated with SPC, LPC, or other lipids in serum-free DMEM for 24 h. Cells were incubated with 0.75 $\mu\text{Ci}/\text{ml}$ [^3H]thymidine in serum-free DMEM for the last 18 h. Cells were harvested onto filter papers presoaked in 1% polyethylenimine using the automated cell harvester HARVEST 96. Incorporated [^3H]thymidine was counted in a 1450 Microbeta Trilux Liquid Scintillation and Luminescence Counter (PerkinElmer Life Sciences).

Cell Migration Assay—Chemotaxis was measured in a modified Boyden chamber assay. Briefly, different lipids were added to the lower chambers. GPR4-ires-GFP- and GFP-Swiss 3T3 cells were serum-starved for 4 h, trypsinized, and seeded in the upper chambers of Boyden Transwell plates (Corning Inc., Corning, NY). The chambers were incubated for 6–8 h. The number of cells that migrated to the lower face of the membrane was counted in 4 random fields. Data are represented as the average \pm S.D. of three independent experiments. For the chemokinetic assay, the same concentrations of lipids were added to both the upper and lower chambers. For Rho inhibition studies, C3-exoenzyme was transiently transfected into Swiss 3T3 cells and cell migration assays were performed 48 h later.

RESULTS

Human RNA Master Blot Probed with GPR4—GPR4 has been shown to be expressed in many human tissues (18). For a

wider analysis of GPR4 expression in human tissues, we probed the Human RNA Master Blot (CLONTECH) containing RNAs from 50 different human tissues with the full-length human GPR4 clone labeled with [^{32}P]dCTP ("Experimental Procedures"). GPR4 showed the highest expression in ovary, liver, lung, kidney, lymph node, and subthalamic nucleus (Fig. 1). Other areas of the brain had a lower expression of GPR4, as did the aorta, placenta, bone marrow, skeletal muscle, spinal cord, prostate, small intestine, and some fetal tissues. GPR4 was also expressed at a detectable level in appendix, trachea, testis, spleen, thymus, pituitary gland, adrenal gland, thyroid gland, and heart, but not in other tissues including some areas of the brain, colon, bladder, uterus, stomach, pancreas, salivary gland, mammary gland, peripheral blood leukocytes, fetal brain, and fetal heart (Fig. 1).

Both SPC- and 16:0-LPC-induced Transient Increases in Intracellular Calcium Concentration ($[\text{Ca}^{2+}]_i$) in GPR4-transfected MCF10A Cells—We have shown that OGR1 is a high affinity receptor for SPC (2). To test whether GPR4, which shares 51% sequence homology with OGR1, is also a receptor for SPC, MCF10A cells were transiently transfected with pGPR4-GFP. MCF10A cells were chosen because these cells do not respond to either SPC or 16:0-LPC in calcium assays and they express very low levels of endogenous GPR4 among many human cell lines tested (Fig. 2).

The GFP receptor fusion was used to identify positively transfected cells, and single-cell calcium assays were performed as described in our previous studies (2). SPC (1 μM) stimulated an increase in $[\text{Ca}^{2+}]_i$ in GPR4-, but not vector-transfected MCF10A cells (Fig. 3A, first and second panels), suggesting that GPR4 is a receptor for SPC. This is further confirmed by the stereoselectivity of GPR4 favoring D-erythro-SPC (the bioactive form of SPC) versus L-threo-SPC (Fig. 3A, third panel). Interestingly, unlike OGR1, which is specific for SPC as its ligand (2), GPR4-transfected cells were stimulated to produce increased $[\text{Ca}^{2+}]_i$ by an additional phosphorylcholine-containing lysolipid, 16:0-LPC (Fig. 3A, fourth panel). To assess the affinities and potencies of SPC and 16:0-LPC, concentrations of each were varied and calcium mobilization was measured (Fig. 3B). SPC appeared to have a higher efficiency ($\text{EC}_{50} = 105 \text{ nM}$) than LPC ($\text{EC}_{50} = 1.1 \mu\text{M}$), although the

FIG. 2. Expression of GPR4 in human cell lines. Real-time quantitative PCR was utilized to determine relative expression levels of GPR4 expressed in cells, as described under "Experimental Procedures." All PCR reactions were performed in triplicate. The comparative C_T method was used to calculate the relative expression levels of GPR4 in different cell lines as described under "Experimental Procedures." HEY, OCC1, NIH:Ovca3, SKOV3, Ovca429, Ovca432, and Ovca433 are ovarian cancer cells. MCF7 is a breast cancer cell line. MCF10A is an immortalized breast cell line. HeLa is a cervical cell line. All cell lines shown, except Swiss 3T3, are human cell lines.

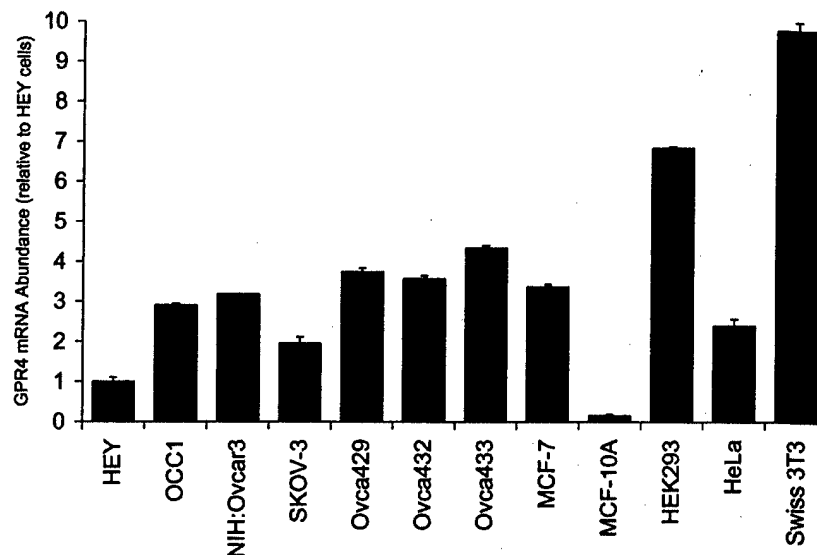

$[Ca^{2+}]_i$ responses to LPC in GPR4-transfected cells were higher than those of SPC at greater concentrations of LPC (up to 10 μM) (Fig. 3B).

LPC has been shown to activate cellular responses in a PAF receptor-dependent manner (19–21). However, LPC and SPC were not able to induce an increase in calcium through the endogenous PAF receptor in parental cells (Fig. 3A, upper panel). Therefore, it is unlikely that the increase in calcium induced by LPC was mediated by a PAF receptor. Nevertheless, to confirm that LPC and/or SPC did not activate the endogenous PAF receptor in GPR4-transfected cells, three specific PAF receptor antagonists, BN52021, WEB-2170, and WEB-2086, were used. Both BN52021 (200 μM) and WEB-2086 (2 μM) completely abolished the calcium signal induced by PAF (100 nM) (Fig. 3, C and D). However, the cellular calcium response to LPC or SPC was not affected, indicating that calcium increases induced by SPC and LPC were not mediated through an endogenous PAF receptor. Another PAF antagonist, WEB-2170 (2 μM), also completely blocked the action of PAF, but did not affect the increase in calcium induced by either LPC or SPC (data not shown). In addition, LPC and SPC showed not only homologous, but also heterologous, desensitization to each other (Fig. 3E), suggesting that these two lipids activated the same receptor.

To determine which G protein is involved in the increased $[Ca^{2+}]_i$ response to SPC and LPC in GPR4-transfected cells, the sensitivity of this activity to PTX was tested. The increase in $[Ca^{2+}]_i$ response to both SPC and LPC, as well as to stimulation of endogenous LPA receptor(s), but not PAF or ATP receptors, was completely abolished by PTX (100 ng/ml, 16 h pretreatment) (Fig. 3F), suggesting the involvement of a G_i pathway.

In plasma, LPC is mainly present in albumin- and lipoprotein-bound forms (22). To determine whether BSA-bound SPC and LPC are able to induce increases in $[Ca^{2+}]_i$, we preincubated SPC (1 μM) and LPC (1 μM) with a molar excess of BSA (0.5% fatty acid-free BSA (Sigma)), for a lipid:BSA molar ratio of ~1:75. At this molar ratio, BSA blocked more than 50 and 95% of the increases in $[Ca^{2+}]_i$ induced by SPC and LPC, respectively (Fig. 3G). These results suggest that albumin-bound LPC may not be able to activate this receptor, and support the concept of multiple LPC compartmentalization (e.g. bound and free) (23).

Recently, Im *et al.* (15) have identified Psy as a ligand for TDAG8. TDAG8 shares ~38% homology with OGR1, GPR4, and G2A (15). To determine whether Psy is a ligand for GPR4,

and to delineate the structural specificity of ligands for GPR4, we tested the effect of Psy, Glu-Sph, Gal-Cer, and Lac-Cer to increase $[Ca^{2+}]_i$ in MCF10A cells. We found that at 1 μM , Psy, Glu-Sph, and Lac-Cer did not stimulate increases in $[Ca^{2+}]_i$ in either MCF10A parental or GPR4-expressing cells (Fig. 3H). Gal-Cer (1 μM) induced the same level of increased $[Ca^{2+}]_i$ in both parental and GPR4-expressing MCF10A cells (Fig. 3H). These data suggest that these glycosphingolipids are unlikely to be ligands of GPR4.

SPC and LPC Bind to GPR4—To characterize the binding of SPC and LPC to GPR4, we conducted radioligand binding assays, using a method similar to that developed for OGR1 as described previously (2). Cell homogenates were used for binding assays. Binding was conducted at 4 °C for 120 min or as indicated. [3H]SPC and [3H]16:0-LPC specifically bound to cell homogenates from GPR4-transfected CHO cells in a time-dependent manner and reached equilibrium after 60 min incubation at 4 °C (Fig. 4, A and B). Both CHO cells and CHO cells transfected with empty vector displayed low background binding of SPC and LPC (Fig. 4, A and B). SPC and 16:0-LPC bindings were saturable and Scatchard analyzes indicated dissociation constants (K_d) of 36 nM for SPC and 159 nM for LPC. The maximum binding capacities for SPC and 16:0-LPC were 996 fmol/ 10^5 cells for SPC and 1,528 fmol/ 10^5 cells for 16:0-LPC (Fig. 4, C and D). SPC ($p < 0.001$) and various LPC species (16:0, 18:0, and 18:1; p values 0.001–0.01), but not LPA (18:1), lysophosphatidylinositol (18:0), S1P, sphingomyelin (18:0), 16:0-PAF, or 16:0-lyso-PAF (p values > 0.05), successfully competed for binding (Fig. 4, E and F). Binding assays using [3H]18:0-LPC gave similar results (data not shown). We also tested the four glycosphingolipids, Psy, Glu-Sph, Gal-Cer, and Lac-Cer, for their ability to compete for the binding of [3H]SPC and [3H]16:0-LPC to GPR4. None of these glycosphingolipids competed successfully (data not shown). Thus, GPR4 was able to specifically bind both SPC and LPC (16:0, 18:0, and 18:1), with a higher affinity for SPC than LPC.

Internalization of GPR4 Induced by SPC and LPC—G protein-coupled receptors undergo agonist-dependent desensitization and internalization (24–26). When HEK293 cells were transfected with the pEGFP-N1 vector, GFP protein was expressed in the cytosol of the cells (2). The GPR4-GFP fusion protein, on the other hand, was expressed only on the plasma membrane (Fig. 5A). One micromolar concentration of SPC and 16:0-LPC, but not 16:0-PAF, induced internalization of GPR4 at 37 °C (Fig. 5, B, C, and F). The PAF receptor-specific antagonist BN52021 did not block the internalization of

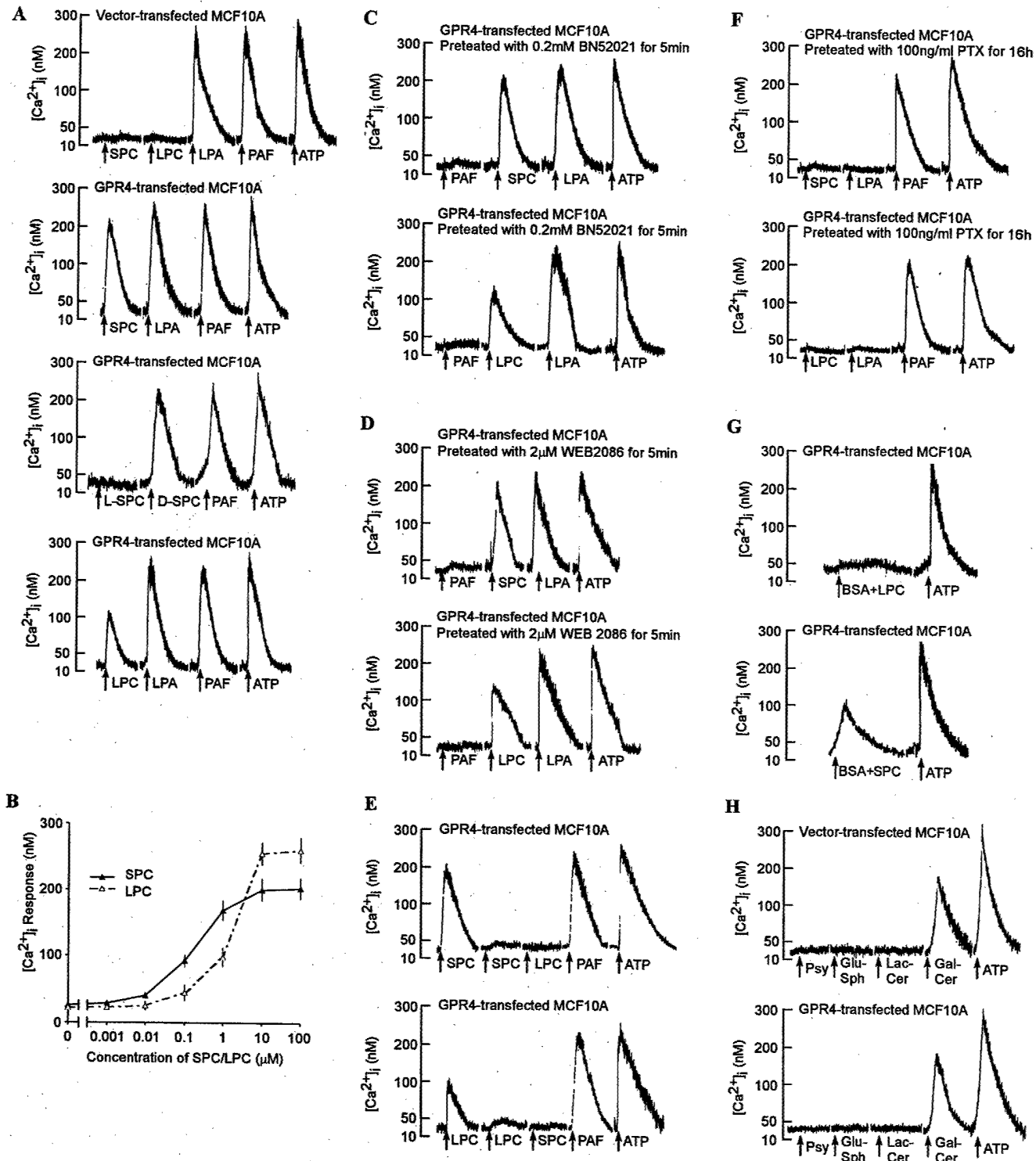

FIG. 3. SPC- and LPC-induced transient increases in $[Ca^{2+}]_i$ in GPR4-transfected MCF10A cells. *A*, upper panel: the effect of SPC (1 μ M), 16:0-LPC (1 μ M), 18:1-LPA (1 μ M), 16:0-PAF (0.1 μ M), and ATP (20 μ M) on $[Ca^{2+}]_i$ in pEGFP-N1-transfected MCF10A cells. The second to fourth panels, MCF10A cells were transiently transfected with pGPR4-GFP, and treated with SPC, L- and D-SPC, LPC, LPA, PAF, or ATP. *B*, SPC and 16:0-LPC concentration response curves in pEGFP-GPR4-transfected MCF10A cells. *C*, the effect of BN52021 on increased $[Ca^{2+}]_i$ induced by agonists. *D*, the effect of WEB-2086 on increased $[Ca^{2+}]_i$ induced by agonists. *E*, homologous and heterologous desensitization of GPR4 by SPC and 16:0-LPC. *F*, the sensitivity of SPC- and 16:0-LPC-induced calcium increases to PTX pretreatment. *G*, the effect of BSA (0.5%) on the ability of SPC and LPC to induce an increase in $[Ca^{2+}]_i$. SPC (1 μ M) and LPC (1 μ M) were incubated with 0.5% fatty acid-free BSA for 30 min at room temperature and the mixtures were used to stimulate MCF10A cells transfected with pGPR4-GFP. *H*, Gal-Cer (1 μ M)-stimulated increase in $[Ca^{2+}]_i$ in parental and pGPR4-GFP expressing MCF10A cells. All calcium measurements were performed in EGTA-containing, calcium-free buffer. The data are representative of at least five independent experiments.

GPR4 induced by either SPC or 16:0-LPC (Fig. 5, *D* and *E*). Similarly, WEB-2170 and WEB-2086 did not affect the internalization of GPR4 induced by either SPC or 16:0-LPC (data not shown).

LPC and SPC Activated the SRE Reporter System in HEK293 Cells—The serum-response element (SRE) reporter system is a sensitive assay for receptors of lipid factors (27, 28). Using the luciferase assay, vector-transfected HEK293

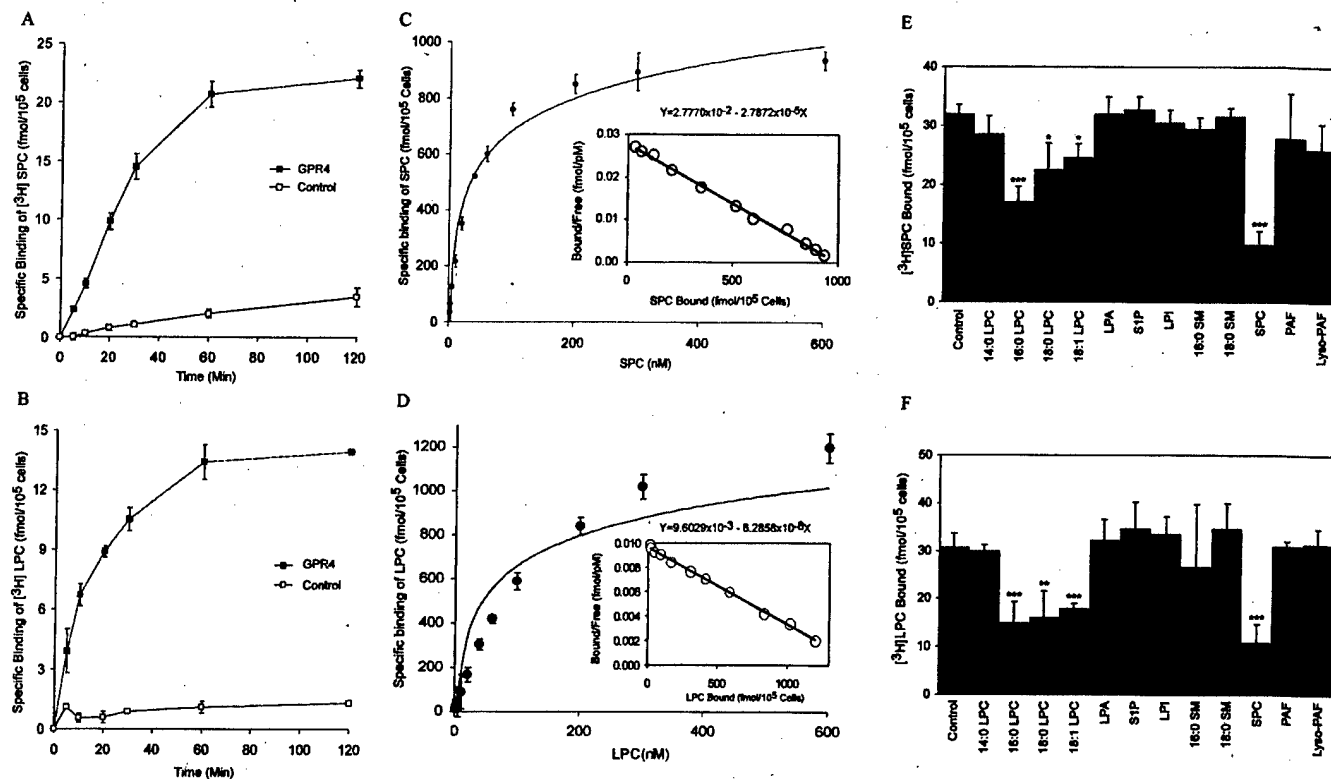
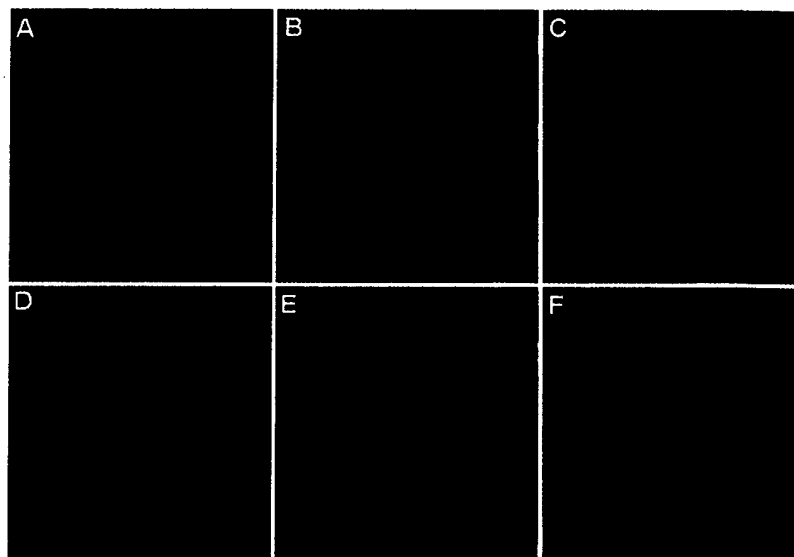

FIG. 4. Binding of SPC and 16:0-LPC to GPR4. A and B, time dependence of specific [³H]SPC and [³H]LPC binding. Cell homogenates (100 μ l, equivalent to 10⁵ cells) from vector or GPR4 stably transfected CHO cells were incubated with [³H]SPC (1 nM) or [³H]16:0-LPC (1 nM) for the indicated times. Specific binding is shown. C and D, saturation isotherm of specific binding of [³H]SPC and [³H]16:0-LPC to GPR4-transfected CHO cells. Cell homogenates (100 μ l) were incubated with the indicated concentrations of [³H]SPC or [³H]16:0-LPC in the presence or absence of unlabeled SPC (100-fold excess) or unlabeled 16:0-LPC (100-fold excess). Specific binding is presented. E and F, structural specificity of binding of [³H]SPC and [³H]16:0-LPC to GPR4. GPR4-transfected CHO cells were incubated with [³H]SPC (1 nM) or [³H]16:0-LPC (1 nM) in the presence or absence of 100 nM of different unlabeled lipids. Total binding is presented. All binding experiments were performed in triplicate in 96-well plates. Data are mean \pm S.D. from three independent experiments. *, $p < 0.05$; **, $p < 0.01$; ***, $p < 0.001$; as compared with the control (Student's *t* test).

FIG. 5. Internalization of GPR4 induced by SPC and LPC. A, HEK293 cells stably expressing pGPR4-GFP. B, pGPR4-GFP stably expressing cells were treated with SPC (1 μ M) at 37 $^{\circ}$ C for 2 h. C, pGPR4-GFP-expressing cells were treated with 16:0-LPC (1 μ M) at 37 $^{\circ}$ C for 2 h. D and E, as in B and C, except cells were pretreated with BN52021 (200 μ M) for 5 min. F, pGPR4-GFP-expressing cells were treated with PAF (1 μ M). All experiments were repeated at least three times. Representative data are shown.



cells transfected with the SRE reporter system responded to SPC (1 μ M), but not 16:0-LPC, with ≤ 1.5 -fold activation (Fig. 6A). Activation was increased 3.1- and 4-fold, respectively, in response to 16:0-LPC (1 μ M) and SPC (1 μ M) in GPR4-transfected HEK293 cells that were also transfected with the SRE reported system (Fig. 6B). These increases were statistically significant ($p < 0.001$) when compared with the responses in vector-transfected cells (Fig. 6A). In contrast, although LPA

and S1P induced significant transcriptional activation of SRE in vector-transfected HEK293 cells, this activation was not altered by GPR4 transfection. In addition, we tested other phosphorylcholine-containing lipids, including 16:0-PAF, 16:0-lyso-PAF, and 18:0-sphingomyelin, and found that none of them induced significant transcriptional activation of SRE (Fig. 6A).

The SRE transcriptional activity in response to SPC, but not

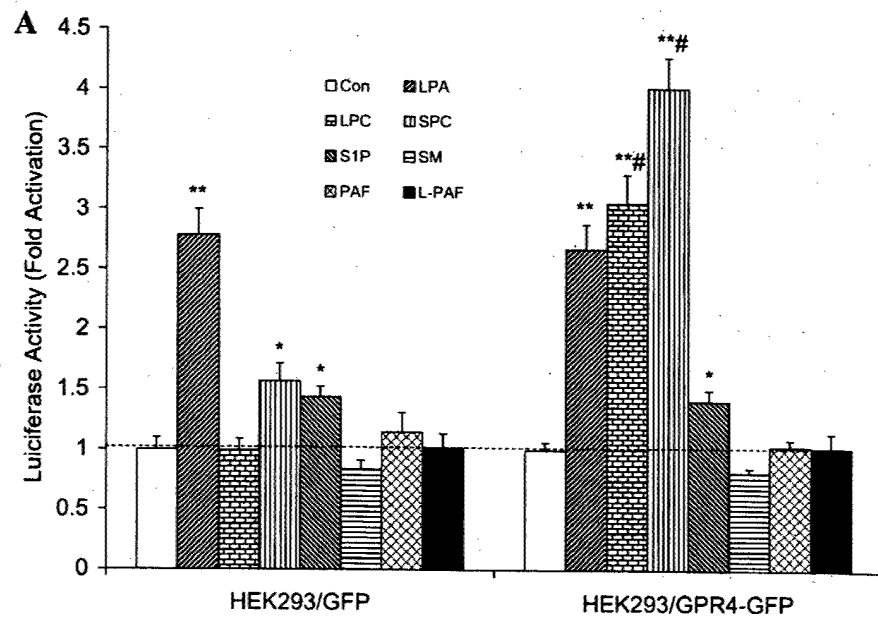
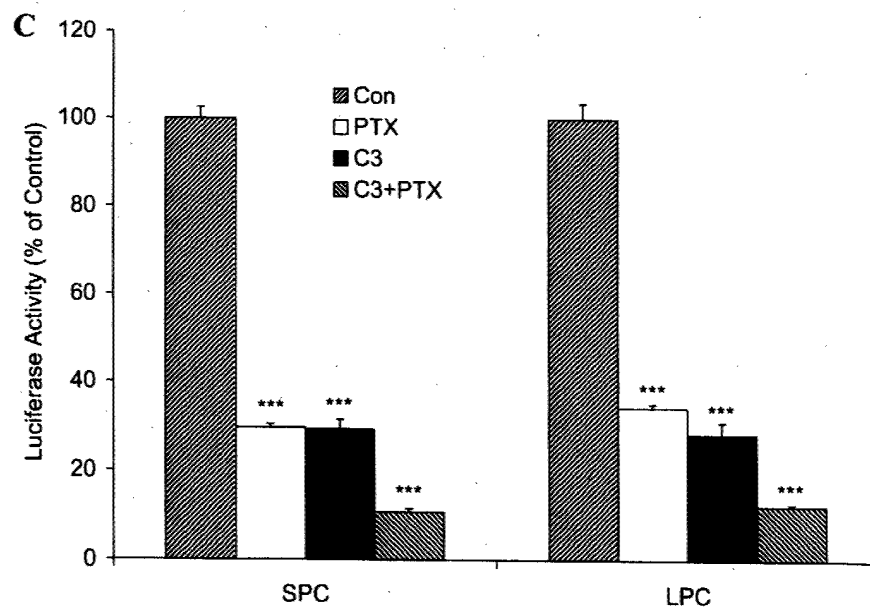
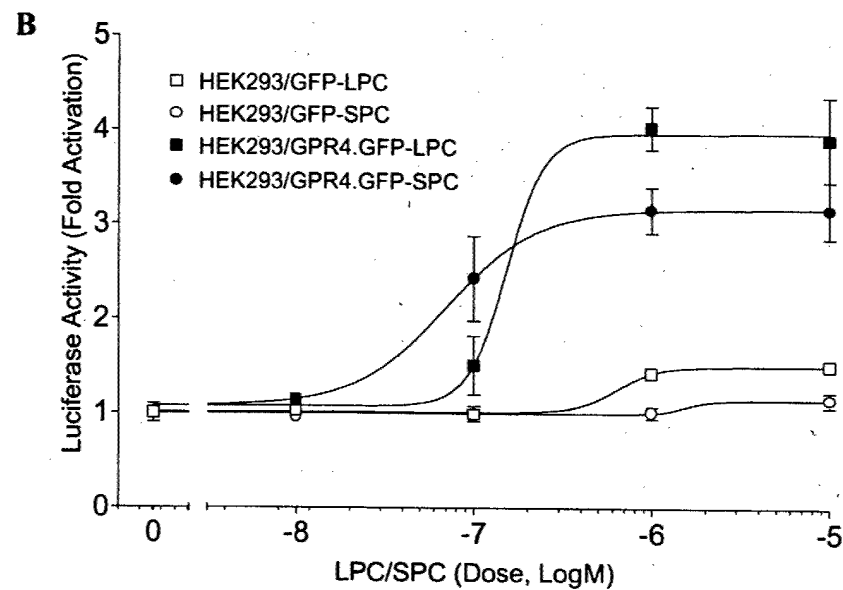

FIG. 6. SPC and LPC activate SRE in a GPR4-dependent manner. *A*, the SRE-luciferase responses to different lipids in vector- and GPR4-transfected HEK293 cells. 18:1-LPA, 16:0-LPC, SPC, S1P, 18:0-sphingomyelin, 16:0-PAF, and 16:0-lyso-PAF (1 μ M each) were used. The experiments were conducted as described under "Experimental Procedures" and "Methods." *B*, concentration-dependent SRE-luciferase activity induced by SPC and 16:0-LPC in vector- and GPR4-transfected cells. *C*, inhibition of SPC- and 16:0-LPC-induced SRE activity by PTX and C3-exoenzyme. All experiments were performed in quadruplicate and were repeated at least three times. Representative data are shown. *Con.*: control; *, $p < 0.05$; **, $p < 0.001$; as compared with the control. #, $p < 0.001$ when compared with SPC- or 16:0-LPC induced activity in vector-transfected cells. The Student's *t* test was performed using the GraphPad Instat software (San Diego, CA). $p < 0.05$ was considered to be statistically significant.



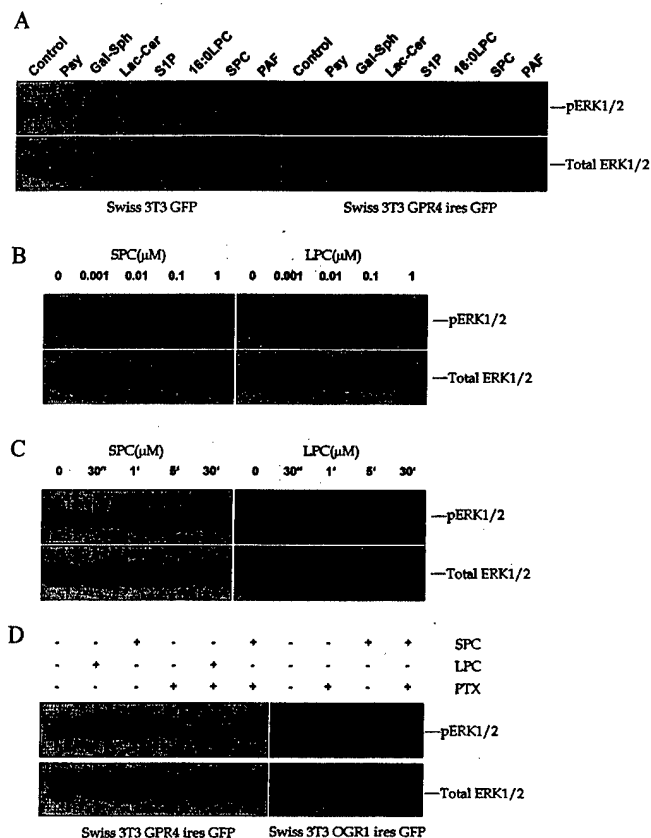

FIG. 7. Activation of ERK MAP kinase by SPC and LPC in GFP- and GPR4-ires-GFP-expressing Swiss 3T3 cells. ERK MAP kinase assays were performed as described under "Experimental Procedures." **A**, structural specificity of lipid-induced ERK activation via GPR4 in Swiss 3T3 cells. Cells were treated with 1 μ M Psy, Gal-Sph, Lac-Cer, sphingosine 1-phosphate (S1P), 16:0-LPC, SPC, and 16:0-PAF for 5 min. **B**, concentration dependence of ERK activation stimulated by SPC and 16:0-LPC. Cells were treated with 1, 10, 100, and 1000 nM 16:0-LPC or SPC for 5 min. **C**, time dependence of ERK activation stimulated by SPC and 16:0-LPC. Cells were treated with SPC (100 nM) or LPC (100 nM) for the indicated time. **D**, GPR4-ires-GFP- and OGR1-ires-GFP-Swiss 3T3 cells were untreated or treated with 16:0-LPC (100 nM) or SPC (100 nM) for 5 min in the absence or presence of PTX (100 ng/ml, 16 h pretreatment).

LPC, in parental HEK293 cells (Fig. 6, A and B), can be explained by the endogenous expression of GPR4 in HEK 293 cells and the relatively lower affinity of GPR4 for LPC compared with SPC. GPR4 transfection enhanced the activation of SRE reporter by both SPC and LPC (Fig. 6, A and B). EC_{50} values for the activation of SRE were 63 nM for SPC and 160 nM for 16:0-LPC. The differences in EC_{50} values obtained using SRE activation from those using the calcium assay (105 nM and 1.1 μ M for SPC and LPC, respectively) are possibly derived from different coupling efficiencies of distinct signaling pathways and/or different cellular environments.

To determine which G protein and other signaling intermediates might be involved in the activation of SRE by SPC and 16:0-LPC, we pretreated cells with PTX (100 ng/ml) for 16 h, or co-transfected the specific Rho inhibitor C3-exoenzyme (1.5 μ g of pcDNA3-C3), with the reporter system. Both PTX and C3-exoenzyme partially inhibited SRE-reporter activation (Fig. 6C). When the two inhibitors were added together, SRE-reporter activation in response to either SPC or 16:0-LPC was almost completely blocked, suggesting that G_i and Rho signaling pathways were involved in SRE activation through GPR4.

SPC and LPC Activated ERK MAP Kinase in a GPR4-dependent Manner—MAP kinases are key signaling intermedi-

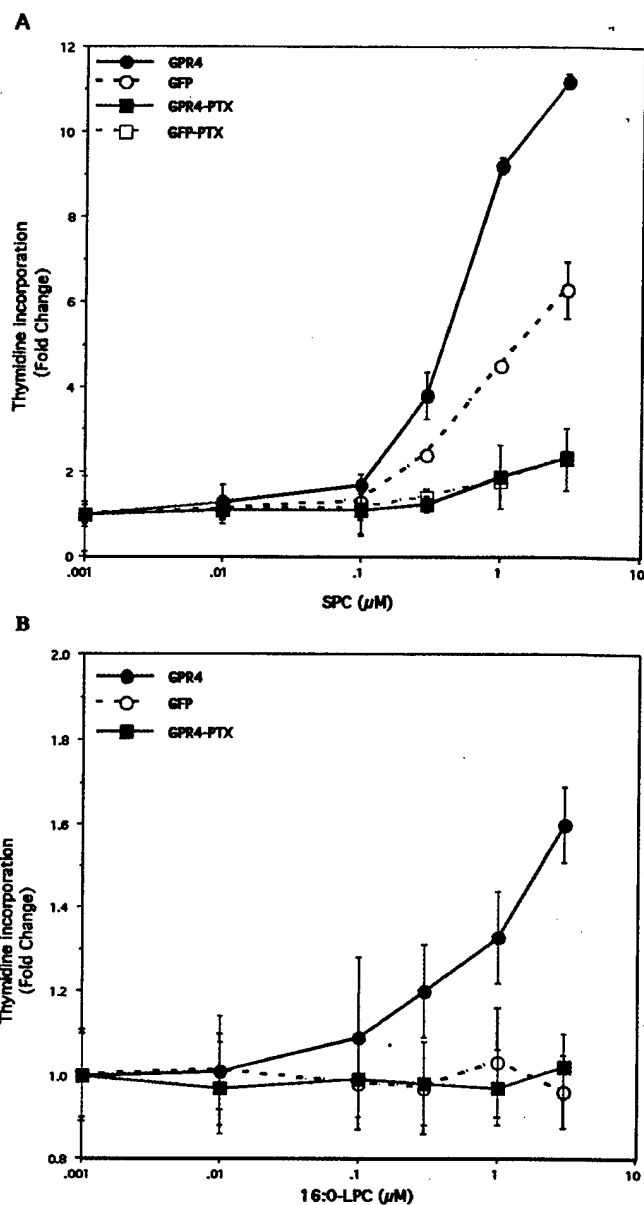

FIG. 8. DNA synthesis stimulated by SPC and 16:0-LPC in GPR4 overexpressing cells. DNA synthesis was measured by [3 H]thymidine incorporation as described under "Experimental Procedures" in both GFP- and GPR4-ires-GFP-Swiss 3T3 cells. PTX was added to selected groups at 100 ng/ml for 16 h prior to lipid treatment. The data shown represent the mean \pm S.D. from three independent experiments.

ates of DNA synthesis and cell proliferation. To determine whether GPR4 mediates ERK MAP kinase activation in response to SPC and LPC, we conducted Western blot analyses of GPR4-ires-GFP-Swiss 3T3 and GFP-Swiss 3T3 cells treated with SPC, 16:0-LPC, and a number of other lipids. The parental and GFP-infected Swiss 3T3 cells showed a basal level of ERK activation, as detected by anti-phospho-ERK antibody (Fig. 7A). SPC (100 nM) increased this level of activation (Fig. 7A). In GPR4-ires-GFP-infected Swiss 3T3 cells, both SPC (100 nM) and LPC (100 nM) enhanced ERK activation, and SPC was more potent than LPC (Fig. 7A). A number of other lipids, including S1P, Lac-Cer, and PAF, also activated ERK in Swiss 3T3 cells, but activation was independent of GPR4 expression (Fig. 7A).

Lipid stock solutions, dissolved in ethanol or MeOH, were ≥ 10 mM. Because the highest final concentration of lipids

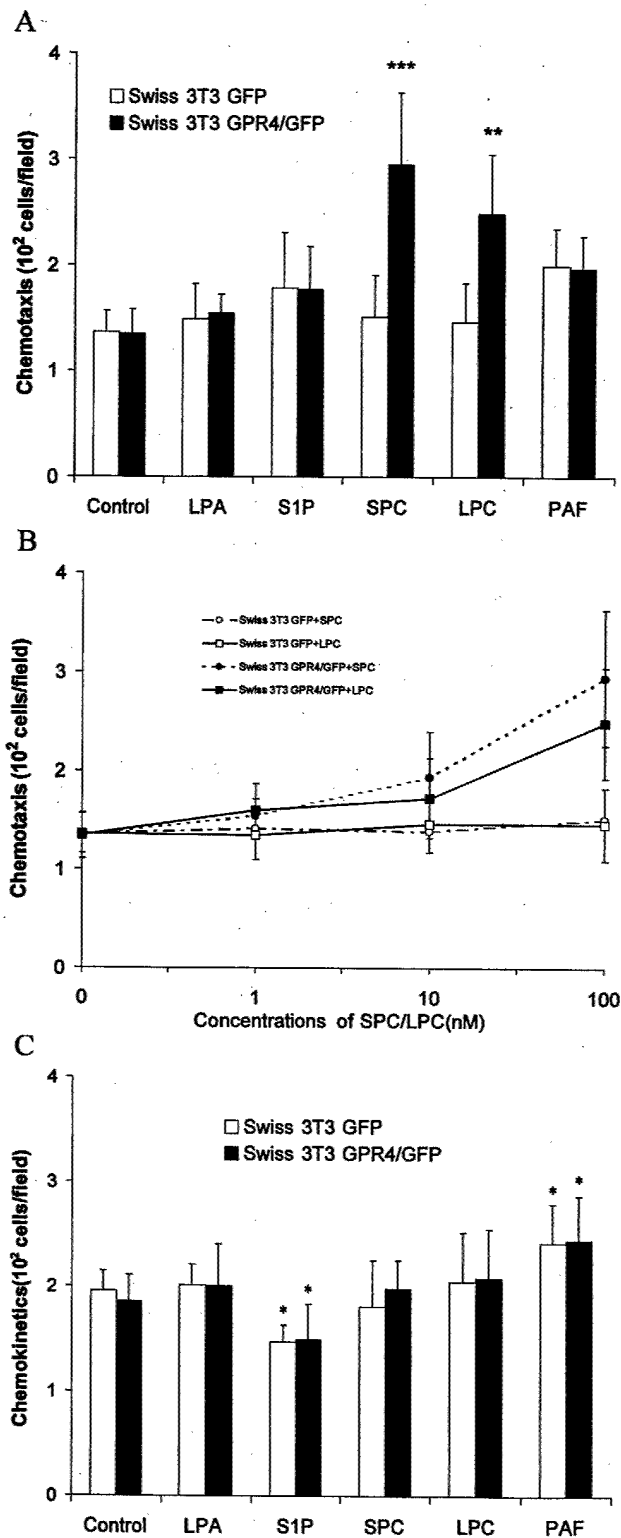

FIG. 9. SPC and LPC stimulate cell migration in GPR4 overexpressing Swiss 3T3 cells. Cell migration was measured in a modified Boyden chamber assay as described under "Experimental Procedures." The cell numbers on the lower faces of the membranes were determined and are presented as the mean \pm S.D. of three independent experiments. **, $p < 0.01$; ***, $p < 0.001$, compared with the control. Student's t test was performed using the GraphPad Instat software (San Diego, CA). $p < 0.05$ was considered to be statistically significant.

70–100% ethanol, and 100% methanol did not alter any parameters tested.

The higher potency of SPC over LPC was further reflected in the concentration- and time-dependent ERK activation (Fig. 7, B and C). ERK activation induced by SPC compared with that by LPC was evident at a lower concentration (~ 10 nM versus 100 nM), at earlier time points (1 min versus 5 min), and was maintained for a longer time. These results strengthen the notion that both SPC and LPC are ligands for GPR4, but SPC has a higher affinity than LPC for GPR4.

In GPR4-infected Swiss 3T3 cells, SPC-induced ERK activation was sensitive to PTX, suggesting involvement of G_i signaling (Fig. 7D). This is in contrast to our previous studies where SPC induced ERK activation via a PTX-insensitive pathway in OGR1-transfected HEK293 cells (2). To determine whether this difference was due to receptor subtype or different cell lines used, we tested the PTX sensitivity of SPC-induced ERK activation in OGR1-infected Swiss 3T3 cells. Our results showed that in Swiss 3T3 cells, SPC-induced ERK activation via OGR1 was PTX-insensitive (Fig. 7D). Thus, although GPR4 and OGR1 are highly homologous, the same high affinity ligand (SPC) induces activation of ERK through a different G protein pathway for each receptor.

SPC Stimulated DNA Synthesis in GPR4-infected Swiss 3T3 Cells—To determine whether SPC and LPC affect DNA synthesis in a GPR4-dependent fashion, we measured [3 H]thymidine incorporation into GPR4-ires-GFP-Swiss 3T3 and GFP-Swiss 3T3 cells. SPC stimulated DNA synthesis in both parental and GFP-infected cells (~ 6.3 -fold increase with 3 μ M SPC). These results are qualitatively consistent with observations by Desai *et al.* (29). This stimulation was further enhanced by the expression of GPR4 (1.8–2-fold increase over GFP-infected Swiss 3T3 cells; Fig. 8A). In both GFP- and GPR4-GFP expressing cells, DNA synthesis stimulated by SPC was inhibited by PTX (Fig. 8A), suggesting G_i signaling was required for this activity. GFP-expressing cells did not respond significantly to 16:0-LPC, whereas [3 H]thymidine incorporation increased 1.6-fold in GPR4-infected Swiss 3T3 cells in response to 3 μ M 16:0-LPC (Fig. 8B). Higher concentration of lipids did not further increase [3 H]thymidine incorporation stimulated by SPC or LPC (data not shown).

SPC and LPC Induced Cell Migration in a GPR4-dependent Manner—As a major component of oxidized low-density lipoprotein, LPC has been proposed to play a role in atherosclerotic lesion development (30, 31). One of the roles of LPC potentially related to atherosclerosis is as a chemoattractant for monocytes, T lymphocytes, and smooth muscle cells (32–34). We used Swiss 3T3 cells infected with GFP or GPR4-ires-GFP as a model system to compare the effects of SPC and 16:0-LPC on cell migration. GPR4 overexpression in Swiss 3T3 fibroblasts increased cell migration in response to SPC (100 nM; lower chamber only) and 16:0-LPC (100 nM; lower chamber only) 2.0- and 1.7-fold, respectively, over that observed in GFP-Swiss 3T3 cells (Fig. 9A). Other lipids (18:1-LPA, S1P, or 16:0-PAF) did not alter cell migration in GPR4- versus vector-transfected cells (Fig. 9A). Cell migration stimulated by both SPC and LPC was inhibited by C3-exoenzyme expression, suggesting that Rho is involved in this process.

Concentration response studies (Fig. 9B) indicate that SPC and LPC were effective at inducing cell migration in the 1–100 nM concentration range. To determine whether this effect was chemotactic or chemokinetic, we measured cells that migrated from the upper to the lower chambers in Boyden chamber assays, conducted with lipids (at 100 nM) in both upper and lower chambers. SPC or 16:0-LPC did not significantly change cell motility when compared with controls (without lipid in

used in this study was 10 μ M, the solvent content was $\leq 0.1\%$ in any experiment. We routinely performed solvent controls and found that at final solvent concentrations of $\leq 0.1\%$,

either chamber) in either GFP or GFP-GPR4 expressing Swiss 3T3 cells (Fig. 9C). S1P slightly inhibited, PAF slightly enhanced, and LPA did not show a significant effect on cell migration in treated *versus* untreated GFP or GFP-GPR4 expressing cells (Fig. 9C). These results suggest that the effect of SPC and 16:0-LPC on cell migration was chemotactic, not chemokinetic, and that the chemotactic effect was mediated through GPR4.

DISCUSSION

GPR4 shares ~50% homology with OGR1. We therefore speculated that these two receptors may have overlapping ligand specificity. Indeed, the results presented here show that GPR4 is a second high affinity receptor for SPC. OGR1 and GPR4 may play both overlapping and distinct physiological and pathological roles. We have shown that OGR1 and GPR4 bind SPC with similar affinities (33 and 36 nM, respectively) and both receptors mediate SPC-induced increases in intracellular calcium and ERK activation. However, GPR4- and OGR1-mediated ERK activation is PTX-sensitive and -insensitive, respectively (Fig. 7A), suggesting that GPR4 and OGR1 couple to different G proteins to activate ERK. More importantly, these differential couplings appear to lead to differential effects on cell proliferation. Whereas OGR1 mediates PTX-insensitive growth inhibition by SPC in a number of cells tested (2), GPR4 mediates PTX-sensitive DNA synthesis by SPC in Swiss 3T3 cells. Together, these data suggested that the endogenous receptor(s) for SPC in Swiss 3T3 cells was GPR4-like, rather than OGR1-like, because parental Swiss 3T3 cells respond to SPC to activate ERK and increase DNA synthesis through a PTX-sensitive pathway (Fig. 8A). The expression of GPR4 in these cells has been confirmed by quantitative PCR analysis (Fig. 2).

GPR4 and OGR1 have different tissue distributions, which may be related to their physiological and pathological roles. Both OGR1 and GPR4 are highly expressed in the lung. However, OGR1 is expressed at high levels in the placenta, spleen, testis, small intestine, and peripheral leukocytes (8, 18), whereas GPR4 is not expressed, or is expressed at relatively low levels, in these tissues. Whereas GPR4 is expressed at high levels, in the liver, kidney, and ovary (Fig. 1), OGR1 is not expressed in these tissues (8, 18). The physiological and pathological roles of these receptors remain to be further investigated.

Another significant finding from this study is the identification of GPR4 as the second G protein-coupled receptor for LPC (the first LPC receptor, G2A, was recently described (14)). GPR4 binds to LPC (in addition to SPC), but not PAF or lyso-PAF, to mediate an increase in intracellular calcium, receptor internalization, SRE activation, MAP kinase activation, DNA synthesis, and cell migration. Although effects of LPC on transmembrane signal transduction have been widely reported, a specific receptor recognizing LPC had not been identified previously (32). LPC lyses cells at high concentrations (>30 μM) (35) and many of the cellular effects previously reported for LPC were observed at high concentrations. Therefore, it is possible that some of the LPC effects *in vivo* are not receptor mediated. On the other hand, evidence has been accumulating to support the notion that, at low concentrations, LPC acts through membrane receptors: (a) at relatively low concentrations ($\leq 10 \mu\text{M}$), LPC exerts cell-specific effects; (b) LPC increases intracellular Ca^{2+} concentration in association with production of inositol phosphates; and (c) these actions of LPC are markedly inhibited by treatment of the cells with PTX and U73122 (36). Some LPC effects are believed to be mediated through the PAF receptor in various cell types, reflected by their partial sensitivity to PAF receptor antagonists (WEB-

2170, WEB-2086, and CV-6209) (21, 22, 37, 38). We have shown in the present study, however, that intracellular calcium increase and receptor internalization induced by LPC are dependent on the expression of GPR4 and are insensitive to the PAF receptor antagonists, BN52021, WEB-2071, and WEB-2086. These results clearly show that LPC does not activate these signaling pathways through PAF receptors. We have identified G2A as the first LPC receptor (14). The expression of G2A is restricted to lymphoid tissues (7), whereas GPR4 is more ubiquitously expressed (Fig. 1). This, together with the different affinities of these two receptors for LPC, may reflect distinct physiological functions for G2A and GPR4.

Physiological concentrations of LPC in body fluids, including blood and ascites, are very high (5–180 μM), when compared with other signaling lipid molecules, such as LPA, S1P and SPC (22, 36, 40, 41).² All receptors would be saturated, down-regulated, and/or desensitized at these concentrations of LPC if it were all in a form available to its receptors. However, different concentrations of LPC present in various cellular and tissue systems (*i.e.* different LPC compartments) may regulate cellular functions differentially (23). LPC in plasma is present mainly in albumin- and lipoprotein-bound forms (22). These forms may be active in some nonreceptor-mediated functions of LPC, such as delivery of fatty acids and choline (22), but may be in a form unavailable for receptor activation. It has been shown that some of the effects of LPC are decreased in the presence of albumin (42). Thus, the functionally available concentration of LPC *in vivo*, and the activation of LPC receptors may be controlled by the lower concentrations of free LPC. Although this issue remains to be further addressed, our results shown in Fig. 3G appear to support this notion. The presence of a 75-fold molar excess of BSA greatly diminished the ability of LPC to elicit an increase in $[\text{Ca}^{2+}]_i$ through the GPR4 receptor. Perhaps physiologically relevant concentrations of LPC *in vivo* that pertain to LPCs interactions with GPR4 will be better understood when estimates of unbound LPC concentrations in specific tissues can be reliably made. *In vivo* the molar ratio of albumin (~3–5% in plasma) to LPC can theoretically be 3–100-fold in plasma. In extravascular sites where albumin concentration is less than in plasma, the ratio of albumin to LPC can be lower.

TDAG8, which shares ~38% homology with OGR1 and GPR4, has recently been shown to be a Psy receptor (15). Treatment of cultured cells expressing this receptor with Psy or structurally related glycosphingolipids results in the formation of globoid, multinuclear cells (15). We have tested the effect of Psy and related glycosphingolipids in calcium mobilization, competition of ligand binding, and MAP kinase activation assays and found no evidence that these lipids interact with GPR4. The questions of whether Psy is also a ligand for GPR4 and whether TDAG8 is a lysophospholipid receptor require further investigation.

It appears that ligands of GPR4-induced cell shape changes (Fig. 5), suggesting that SPC and LPC may affect the cellular cytoskeleton. Both LPA and S1P are able to affect cytoskeleton through Rho (39, 43). SPC and LPC are also able to activate Rho, as evidenced by C3-exoenzyme sensitivity of SRE reporter activity (Fig. 6) and cell migration (Fig. 9) induced by SPC/LPC. It remains to be determined whether the cell shape change induced by SPC/LPC is a Rho-mediated effect and which cellular proteins are involved in this processes.

Different cell lines (MCF10A, HEK293, CHO, and Swiss 3T3 cells) were used in our studies. As shown in Fig. 2, MCF10A cells expressed the lowest level of endogenous GPR4 among cell

² Y.-J. Xiao and Y. Xu, unpublished results.

lines tested. This cell line does not respond to either SPC or LPC in calcium assays (2). Therefore, calcium assays described here were performed in these cells. Because the transfection efficiency of MCF10A cells is very low (2), we were unable to establish stably expressing lines for conducting other assays. Despite their relatively high level of GPR4 expression, HEK293 cells were chosen for the internalization and SRE reporter assays, mainly because they are human in origin, and also yielded a high transfection efficiency (Fig. 1). The internalization assays utilized transfected receptor-GFP fusion proteins and the transcriptional responses in SRE reporter assays were compared with those in parental or vector-transfected cells. Therefore, the effects of the exogenous GPR4 receptor were readily separable from those of the endogenous receptor(s). CHO cells were chosen for binding assays, because they exhibit low responses to SPC and LPC in calcium assays and are readily transfected. We detected SPC- and LPC-induced MAP kinase activation through GPR4 in Swiss 3T3, but not HEK293 and CHO cells (Fig. 7 and data not shown). Hence, Swiss 3T3 cells were chosen for MAP kinase activation and mitogenic studies. It is well known that receptor-mediated signaling transduction is dependent on multiple cellular factors. The molecular basis for the differential activation of GPR4 in different cells remains to be further explored.

In summary, our results indicate that SPC is a high affinity, and LPC a lower affinity, ligand for GPR4. This conclusion is directly derived from the results of ligand binding assays (K_d values of 36 versus 159 nM for SPC and 16:0-LPC, respectively). This is also supported by results from assays of different signaling pathways activated by SPC and LPC, including increases in calcium, transcriptional activation of SRE, ERK activation, and stimulation of DNA synthesis and cell migration. In recent decades, many reports have described a significant elevation of LPC levels in cells and tissues in different diseases (9, 32, 41). Numerous lines of evidence suggest that LPC, which is a major lipid component of oxidized low density lipoprotein, and which accumulates in atherosclerotic lesions (11), plays pathological roles in the development of atherosclerosis and other chronic inflammatory diseases (11, 12). LPC also plays other important biological roles. For example, LPC functions as a fatty acid and choline carrier and delivers fatty acids more specifically to brain than other tissues (22). The identification of GPR4 as a receptor for LPC and SPC solidifies the assignment of a new lysophospholipid receptor subfamily (OGR1, GPR4, and G2A). Further studies should address possible functional redundancy among these receptors and add important information to our understanding of inflammatory diseases.

Acknowledgments—We thank Dr. Bryan Williams and Dr. Guy Chisolm for critical reading of this manuscript.

REFERENCES

1. Spiegel, S., and Milstien, S. (1995) *J. Membr. Biol.* **146**, 225–237
2. Xu, Y., Zhu, K., Hong, G., Wu, W., Baudhuin, L. M., Xiao, Y., and Damron, D. S. (2000) *Nat. Cell. Biol.* **2**, 261–267
3. Heiber, M., Docherty, J. M., Shah, G., Nguyen, T., Cheng, R., Heng, H. H., Marchese, A., Tsui, L. C., Shi, X., and George, S. R. (1995) *DNA Cell Biol.* **14**, 25–35
4. Mahadevan, M. S., Baird, S., Bailly, J. E., Shuttler, G. G., Sabourin, L. A., Tsilifidis, C., Neville, C. E., Narang, M., and Korneluk, R. G. (1995) *Genomics* **30**, 84–88
5. Choi, J., Lee, S., and Choi, Y. (1996) *Cell. Immunol.* **168**, 78–84
6. Kyaw, H., Zeng, Z., Su, K., Fan, P., Shell, B., Carter, K., and Li, Y. (1998) *DNA Cell Biol.* **17**, 493–500
7. Weng, Z., Fluckiger, A. C., Nisitani, S., Wahl, M. I., Le, L. Q., Hunter, C. A., Fernald, A. A., Le Beau, M. M., and Witte, O. N. (1998) *Proc. Natl. Acad. Sci. U. S. A.* **95**, 12334–12339
8. Xu, Y., and Casey, G. (1996) *Genomics* **35**, 397–402
9. Murphy, A. A., Santanam, N., Morales, A. J., and Parthasarathy, S. (1998) *J. Clin. Endocrinol. Metab.* **83**, 2110–2113
10. Choi, J. W., Lee, S. Y., and Choi, Y. (1996) *Cell. Immunol.* **168**, 78–84
11. Chisolm, G., III, and Penn, M. (1996) *Oxidized Lipoproteins and Atherosclerosis*, Lippincott-Raven Publishers, Philadelphia, PA
12. Yokota, T., and Hansson, G. (1995) *J. Intern. Med.* **238**, 479–489
13. Murrugesan, G., and Fox, P. L. (1996) *J. Clin. Invest.* **97**, 2736–2744
14. Kabarowski, J. H. S., Zhu, K., Le, L. Q., Witte, O. N., and Xu, Y. (2001) *Science* **293**, 702–705
15. Im, D. S., Heise, C. E., Nguyen, T., O'Dowd, B. F., and Lynch, K. R. (2001) *J. Cell Biol.* **153**, 429–441
16. Kabarowski, J. H. S., Feramisco, J. D., Le, L. Q., Gu, J. L., Luoh, S. W., Simon, M. I., and Witte, O. N. (2000) *Proc. Natl. Acad. Sci. U. S. A.* **97**, 12109–12114
17. Gryniewicz, G., Poenie, M., and Tsien, R. Y. (1985) *J. Biol. Chem.* **260**, 3440–3450
18. An, S., Tsai, C., and Goetzl, E. J. (1995) *FEBS Letters* **375**, 121–124
19. Ogita, T., Tanaka, Y., Nakaoka, T., Matsuoka, R., Kira, Y., Nakamura, M., Shimizu, T., and Fujita, T. (1997) *Am. J. Physiol.* **272**, H17–24
20. Gomez-Munoz, A., O'Brien, L., Hundal, R., and Steinbrecher, U. P. (1999) *J. Lipid Res.* **40**, 988–993
21. Huang, Y. H., Schafer-Elinder, L., Wu, R., Claesson, H. E., and Frostegard, J. (1999) *Clin. Exp. Immunol.* **116**, 326–331
22. Croset, M., Brossard, N., Polette, A., and Lagarde, M. (2000) *Biochem. J.* **345**, 61–67
23. Carson, M. J., and Lo, D. (2001) *Science* **293**, 618–619
24. Mukherjee, S., Ghosh, R. N., and Maxfield, F. R. (1997) *Physiol. Rev.* **77**, 759–803
25. Bohm, S. K., Grady, E. F., and Bunnett, N. W. (1997) *Biochem. J.* **322**, 1–18
26. Ferguson, S. S., Barak, L. S., Zhang, J., and Caron, M. G. (1996) *Can. J. Physiol. Pharmacol.* **74**, 1095–1110
27. An, S., Bleu, T., Hallmark, O. G., and Goetzl, E. J. (1998) *J. Biol. Chem.* **273**, 7906–7910
28. An, S., Bleu, T., and Zheng, Y. (1999) *Mol. Pharmacol.* **55**, 787–794
29. Desai, N. N., Carlson, R. O., Mattie, M. E., Buckley, N. E., Seki, T., Brooker, G., and Spiegel, S. (1993) *J. Cell Biol.* **121**, 1385–1395
30. Lusis, A. J. (2000) *Nature* **407**, 233–241
31. Chisolm, G. M., III, and Chai, Y. (2000) *Free Radic. Biol. Med.* **28**, 1697–1707
32. Prokazova, N. V., Zvezdina, N. D., and Korotaeva, A. A. (1998) *Biochemistry (Moscow)* **63**, 31–37
33. Kohno, M., Yokokawa, K., Yasunari, K., Minami, M., Kano, H., Hanehira, T., and Yoshikawa, J. (1998) *Circulation* **98**, 353–359
34. McMurray, H. F., Parthasarathy, S., and Steinberg, D. (1993) *J. Clin. Invest.* **92**, 1004–1008
35. Jalink, K., van Corven, E. J., and Moolenaar, W. H. (1990) *J. Biol. Chem.* **265**, 12232–12239
36. Okajima, F., Sato, K., Tomura, H., Kuwabara, A., Nochi, H., Tamoto, K., Kondo, Y., Tokumitsu, Y., and Ui, M. (1998) *Biochem. J.* **336**, 491–500
37. Hirayama, T., Ogawa, Y., Tobise, K., and Kikuchi, K. (1998) *Hyperten. Res.* **21**, 137–145
38. Ogita, T., Tanaka, Y., Nakaoka, T., Matsuoka, R., Kira, Y., Nakamura, M., Shimizu, T., and Fujita, T. (1997) *Am. J. Physiol.* **272**, H17–24
39. Moolenaar, W. H. (1999) *Exp. Cell Res.* **253**, 230–238
40. Sasagawa, T., Suzuki, K., Shiota, T., Kondo, T., and Okita, M. (1998) *J. Nutr. Sci. Vitamin.* **44**, 809–818
41. Okita, M., Gaudette, D. C., Mills, G. B., and Holub, B. J. (1997) *Int. J. Cancer* **71**, 31–34
42. Mochizuki, M., Zigler, J. S., Jr., Russell, P., and Gery, I. (1982–1983) *Curr. Eye Res.* **2**, 621–624
43. Goetzl, E. J., and An, S. (1998) *FASEB J.* **12**, 1589–1598

Review

sphingosylphosphorylcholine and lysophosphatidylcholine: G protein-coupled receptors and receptor-mediated signal transduction

Yan Xu*

Department of Cancer Biology, Lerner Research Institute, Cleveland Clinic Foundation, 9500 Euclid Avenue, Cleveland, OH 44195, USA

Department of Gynecology and Obstetrics, Cleveland Clinic Foundation, 9500 Euclid Avenue, Cleveland, OH 44195, USA

Received 30 January 2002; accepted 30 January 2002

Abstract

In recent years, certain lysophospholipids (lyso-PLs) have been recognized as important cell signaling molecules. Among them, two phosphorylcholine-containing lyso-PLs, sphingosylphosphorylcholine (SPC) and lysophosphatidylcholine (LPC), have been shown to be involved in many cellular processes and are produced under physiological and pathological conditions. Although signaling properties of SPC and LPC have been studied in a variety of cellular systems, specific cell membrane receptors for SPC and LPC have not been identified previously. Recently, ovarian cancer G protein-coupled receptor 1 (OGR1, also known as GPR68), G protein-coupled receptor 4 (GPR4), and G2A have been identified as receptors for SPC and LPC. The signaling and ligand-binding properties of these receptors are reviewed here. These discoveries provide an intriguing opportunity and a novel approach in studying the pathophysiological roles of SPC and LPC and their receptors. © 2002 Elsevier Science B.V. All rights reserved.

Keywords: G protein-coupled receptor; Sphingosylphosphorylcholine; Lysophosphatidylcholine; Ovarian cancer G protein-coupled receptor 1; G2A; G protein-coupled receptor 4

1. Introduction

In recent years, certain lysophospholipids (lyso-PLs) have been recognized as important cell signaling molecules [1,2]. Among them, two phosphorylcholine-containing lyso-PLs, sphingosylphosphorylcholine (SPC) and lysophosphatidylcholine (LPC), both produced under physio-

logical and pathological conditions, have been shown to be involved in many cellular processes. SPC induces both cell proliferation and growth inhibition. It has been implicated in a number of biological processes, including smooth muscle contraction, wound healing, and angiogenesis [3–10]. LPC is a major plasma lipid component and transports fatty acids and choline to tissues [11]. It plays an important role in atherosclerosis and inflammatory diseases [12–14]. SPC and LPC are produced under physiological and pathological conditions. Although signaling properties of SPC and LPC have been studied in a variety of cellular systems, specific cell membrane receptors for SPC and LPC had not been identified previously.

Four G protein-coupled receptors (GPCRs), ovarian cancer G protein-coupled receptor 1 (OGR1, also known as GPR68), G protein-coupled receptor 4 (GPR4), G2A, and T cell death-associated gene 8 (TDAG8), belong to a new subfamily of GPCRs (we designate them as the “OGR1 subfamily”) that share 36–51% sequence identity to each other and approximately 30% sequence homology with the platelet-activating factor (PAF) receptor [15–20]. We have recently identified the legends for OGR1, G2A, and GPR4 as SPC and/or LPC [21–23]. These discoveries

Abbreviations: BSA, bovine serum albumin; ERK, extracellular signal-regulated kinase; Gal-Cer, galactosyl- β 1,1'-ceramide; Glu-Sph, glucosyl- β 1,1'-sphingosine; GPCRs, G protein-coupled receptors; IP₃, inositol triphosphate; Lac-Cer, lactosyl- β 1,1'-ceramide; LPA, lysophosphatidic acid; LPI, lysophosphatidylinositol; lyso-PLs, lysophospholipids; MAP kinase, mitogen-activated protein kinase; OGR1, ovarian cancer G-protein-coupled receptor 1; PAF, platelet-activating factor; PCR, polymerase chain reaction; PKC, protein kinase C; PMA, phorbol-12-myristate-13-acetate; PTX, pertussis toxin; S1P, sphingosine-1-phosphate; SM, sphingomyelin; SRE, serum response element; SRF, serum response factor; TDAG8, T cell death-associated gene 8.

* Department of Cancer Biology, Lerner Research Institute, Cleveland Clinic Foundation, 9500 Euclid Avenue, Cleveland, OH 44195, USA. Fax: +1-216-445-6269.

E-mail address: xuy@ccf.org (Y. Xu).

provide an intriguing opportunity and a novel approach to studying the pathophysiological roles of SPC and LPC and their receptors.

2. Identification of receptors for SPC and LPC

In an attempt to identify receptor for lyso-PLs, we employed a polymerase chain reaction (PCR)-based cloning strategy. We designed degenerated PCR primers based on the sequences of receptors for PAF and thrombin. PAF is structurally related to lyso-PLs. Thrombin activates similar or identical signaling pathways to those induced by certain lyso-PLs, such as lysophosphatidic acid (LPA). Using this approach, we identified a GPCR clone from HEY (an ovarian cancer cell line) cells, which we term OGR1. An et al. [18] previously cloned a similar or identical GPCR termed GPR12A (two amino acids are different in the derived protein sequences from the two clones) by a PCR strategy using degenerate primers designed from sequences conserved among receptors for inflammatory mediators. The ligand for this receptor was unknown previously, and it shares little sequence homology with identified LPA and sphingosine-1-phosphate (S1P) receptors (LPA_{1–3} and S1P_{1–5}).

OGR1 shares approximately 30% sequence homology with the PAF receptor. We tested two structurally similar lyso-PLs, SPC and LPC, to determine if they might be ligands for OGR1. MCF10A, an immortalized breast cell line, does not express OGR1, as analyzed using poly-A mRNA Northern blot, RNase protection and quantitative PCR analyses [21]. In addition, these cells do not respond to either SPC or LPC (up to 10 μ M of lipids) to increase in $[Ca^{2+}]_i$. Using this cell line overexpressing OGR1, we observed OGR1-mediated calcium mobilization induced by SPC. This was the first evidence that OGR1 is a receptor for SPC. Additional pharmacological and functional assays, including ligand binding, receptor internalization, mitogen-activated protein (MAP) kinase activation, serum response element (SRE) reporter activities, cell proliferation, and cell migration, were performed to establish the receptor–ligand relationship and characterize the signaling properties of these receptors [21].

After identification of SPC as a high-affinity ligand for OGR1, we postulated that SPC and/or LPC could be ligands for G2A and GPR4. Indeed, our studies indicate that G2A and GPR4 are receptors for both SPC and LPC [22,23]. Interestingly, these receptors display differential affinities towards SPC and LPC (summarized below). TDAG8 also shares 36–40% sequence homology with OGR1, G2A and GPR4. Im et al. [24] have recently identified the glycosphingolipid, psychosine (galactosyl- β 1-1'-sphingosine), as a ligand for TDAG8. Whether additional lipids may also act as ligands for TDAG8 remains to be further investigated. This review will focus on OGR1, G2A, and GPR4 as SPC/LPC receptors. The signaling properties of SPC and LPC

mediated through OGR1, G2A, and GPR4 are summarized in a comparative fashion below.

3. Intracellular calcium release induced by SPC and LPC via OGR1 subfamily receptors

Ligand-induced increases in $[Ca^{2+}]_i$, (in particular, $[Ca^{2+}]_i$ release from intracellular stores) are characteristic of many GPCRs. Calcium release from intracellular stores usually requires generation of inositol triphosphate (IP₃), although IP₃-independent calcium mobilization also exists. IP₃ is produced by phospholipase C (PLC), which is activated by GPCRs through either G_{i/o} or G_{q/11} proteins. As summarized in Table 1 below, OGR1, GPR4, and G2A induce transient elevations in $[Ca^{2+}]_i$, with differential EC₅₀ values for SPC and/or LPC.

SPL/LPL-induced calcium release (assays were conducted in the presence of EGTA to eliminate extracellular calcium) mediated by all three receptors in MCF10A cells is pertussis toxin (PTX)-sensitive, suggesting that a G_{i/o} type of G protein is involved. PAF and adenosine triphosphate stimulate calcium release in MCF10A cells through PTX-insensitive G proteins, indicating that the coupling to G_{i/o} is not a result of impaired of G_q signaling in these cells. It is well known that G protein coupling can be cell-type dependent, but it remains to be determined whether this is the case for G_{i/o}-dependent calcium signaling mediated through the OGR1 subfamily receptors.

An interesting feature of calcium signaling mediated by the OGR1 subfamily is the sensitivity of OGR1 receptors to pretreatment with phorbol-12-myristate-13-acetate (PMA). Although the underlying mechanisms of this sensitivity have not been directly studied, it is speculated that protein kinase C (PKC) activity, which is induced by PMA treatment, is involved in receptor phosphorylation and down-regulation. The role of PKC in phosphorylation and modulation of GPCRs has been extensively documented [25,26]. There are several putative PKC phosphorylation sites in OGR1, G2A, and GPR4 [15].

Table 1
Characteristics of increases in $[Ca^{2+}]_i$ induced by SPC and/or LPC via OGR1 subfamily receptors and PAFR in MCF10A cells

	OGR1	G2A	GPR4	PAF
Ligand	SPC	LPC, SPC	SPC, LPC	PAF
EC ₅₀	35 nM	100 nM (LPC), 400 nM (SPC)	105 nM (SPC), 1.1 μ M (LPC)	0.3 nM [69]
G protein	G _i	G _i	G _i	G _q
PAFR	Insensitive	Insensitive	Insensitive	Sensitive
antagonists				
PMA	Sensitive	Sensitive	Sensitive	Insensitive
Reference	[21]	[22]	[23]	[69,70]

PAFR: PAF receptor.

4. Ligand-binding properties of OGR1 subfamily receptors

To characterize the binding properties of SPC and LPC to OGR1 subfamily receptors, we have developed a radioligand binding assay for SPC and LPC. Table 2 summarizes the binding properties from three of the OGR1 subfamily receptors. Although OGR1 is a specific and high-affinity receptor for SPC, GPR4 and G2A are receptors for both SPC and LPC. Interestingly, each of these receptors shows a distinctive pattern of preference to the two ligands. GPR4 has a higher affinity for SPC ($K_d = 35.9$ nM) more than LPC ($K_d = 159$ nM), and G2A has a higher affinity for LPC ($K_d = 64.8$ nM) more than SPC ($K_d = 229$ nM). To determine the ligand specificity of these receptors, many structurally related lipid molecules were tested for their ability to compete with [3 H]SPC and [3 H]16:0-LPC. These lipids include LPA, S1P, lysophosphatidylinositol (LPI), PAF, lyso-PAF, sphingomyelin (SM), ceramide, psychosine, glucosyl- β 1,1'-sphingosine (Glu-Sph), galactosyl- β 1,1'-ceramide (Gal-Cer), and lactosyl- β 1,1'-ceramide (Lac-Cer). None of these lipids were able to compete with the binding of [3 H]SPC and [3 H]16:0-LPC, indicating that OGR1, G2A, and GPR4 are receptors specific for SPC and/or LPC. The binding properties of these receptors remain to be further characterized using more pharmacological approaches, including displacement experiments.

5. MAP kinase activation and the mitogenic effects mediated through OGR1

OGR1, G2A, and GPR4 display distinct patterns of extracellular signal-regulated kinase (ERK) activation (Table 3). SPC induces ERK activation via both OGR1 and GPR4 in Swiss 3T3 cells [23]. However, ERK activation mediated by GPR4 is PTX-sensitive, whereas that mediated by OGR1 is PTX-insensitive, suggesting that GPR4 and OGR1 couple to different G proteins to activate ERK. More importantly, these differential couplings appear to lead to differential effects on cell proliferation. Whereas OGR1 mediates PTX-insensitive growth inhibition by SPC in a number of cells tested [21], GPR4 mediates PTX-sensitive DNA synthesis by SPC in Swiss 3T3 cells [23].

SPC is a potent mitogen for a number of nonmalignant cell types, including Swiss and other 3T3 fibroblasts [4,27], kera-

Table 3
MAP kinase activation via OGR1 subfamily receptors

	OGR1	G2A	GPR4
SPC	++	+	+++
LPC	–	+++	+
PTX sensitivity	No	Yes	Yes
U73122 sensitivity	Yes	n.d.	n.d.
Cell line responsible	Swiss 3T3, HEK293	Swiss 3T3, CHO	Swiss 3T3
Reference	[21]	[22]	[23]

+, ++, +++: positive responses, with +++ as the relatively strongest response; –: no response; n.d.: not determined.

tinocytes [7], and resting spleen cells in vitro [28], as well as for many cell types involved in wound healing, including fibroblasts, endothelial cells and cells around sebaceous glands, and hair follicles in vivo [9]. SPC also stimulates hypertrophic growth of cardiac myocytes and [3 H]thymidine incorporation in resting, but not Con-A-activated, splenocytes [28,29]. On the other hand, we and others have shown that SPC is a potent growth inhibitor for a number of malignant cells, including Jurkat leukemia [30], ovarian, breast [6], and pancreatic cancer cells [5]. The mechanisms underlying this differential growth regulation were not revealed previously. The identification and characterization of the two high-affinity receptors for SPC, OGR1, and GPR4 may provide intriguing insights on how these effects are regulated.

Our data suggest that OGR1 mediates the growth inhibitory effect and GPR4 mediates the growth stimulatory effect of SPC [21,23]. HEK293 cells express endogenous GPR4, but not OGR1, and they respond to SPC with growth stimulation [21]. However, when OGR1 is overexpressed in HEK293 cells, SPC induces inhibition of cell growth [21]. Overexpression of OGR1 also confers a growth inhibitory effect of SPC in HeLa and Swiss 3T3 cells [21,23]. As shown by Desai and Spiegel [27], SPC stimulates DNA synthesis in Swiss 3T3 cells. We have detected relatively high levels of expression of endogenous GPR4 in these cells [23]. However, when human OGR1 is overexpressed in 3T3 cells, it converts the growth stimulatory effect of SPC to a growth inhibitory effect (our unpublished results). In contrast, when human GPR4 is overexpressed in these cells, it enhances the growth stimulatory effect of SPC [23]. Two ovarian cancer cell lines, HEY and OCC1, as well as Jurkat, and the breast cancer cell line, MCF7, express endogenous OGR1, and they respond to SPC with growth inhibition. Interestingly, these

Table 2
Ligand-binding properties of OGR1 subfamily receptors

	OGR1	G2A	GPR4
SPC	$K_d = 33.3$ nM $B_{max} = 1107$ fmol/ 10^5 cells (HEK293) Competitors: SPC	$K_d = 228.9$ nM $B_{max} = 1840$ fmol/ 10^5 cells (HEK293) Competitors: SPC, LPC	$K_d = 35.9$ nM $B_{max} = 996$ fmol/ 10^5 cells (CHO) Competitors: SPC, LPC
LPC	No binding	$K_d = 64.8$ nM $B_{max} = 1503$ fmol/ 10^5 cells (HEK293) Competitors: SPC, LPC	$K_d = 159.1$ nM $B_{max} = 1528$ fmol/ 10^5 cells (CHO) Competitors: SPC, LPC
Reference	[21]	[22]	[23]

cells also express endogenous GPR4 [23]. It is possible that either OGR1 plays a dominant role or the balance between these two receptors is responsible for determining the growth response to SPC, which needs to be further addressed. The growth inhibitory and stimulatory effects of SPC mediated by OGR1 are PTX-insensitive and those mediated by GPR4 are PTX-sensitive, suggesting that different G proteins are involved in the differential growth effects of SPC. This work has formed a basis for further exploration of the mechanisms of SPC- and LPC-regulated DNA synthesis and cell proliferation in different cellular systems.

6. Rho-dependent activities of SPC and LPC

Rho-dependent activities induced by SPC and LPC through their receptors include induction of transcriptional activity through SRE, actin rearrangement, and cell migration [23,31]. SPC and 16:0-LPC induce a concentration-dependent activation of SRE in GPR4-transfected HEK293 cells [23]. Both PTX and C3-exoenzyme (a specific inhibitor of Rho) partially inhibit SRE-reporter activation. When the two inhibitors are added together, SRE-reporter activation in response to either SPC or 16:0-LPC is almost completely blocked, suggesting that G_i and Rho signaling pathways are involved in SRE activation through GPR4. SPC, but not LPC, also induces transcription activation of SRE via OGR1 (unpublished results).

G2A activates Rho via $G_{\alpha 13}$, leading to actin rearrangement and serum response factor-dependent transcription activation [32]. SPC- and LPC-induced cell migration (chemotaxis) via GPR4 is sensitive to C3-exoenzyme [23]. LPC also induces cell migration in a G2A-dependent manner in Jurkat T cells [22]. As a major component of oxidized low-density lipoprotein, LPC has been proposed to play a role in atherosclerotic lesion development [12,31]. One of the major effects of LPC on cells involved in atherosclerosis and other chronic inflammatory diseases is chemoattraction of T cells and macrophages [33,34]. The role of LPC receptors (GPR4 and G2A) in cell migration under physiological conditions remains to be determined.

7. LPC compartmentation and nonreceptor-mediated effects of LPC

Unlike other lipid signaling molecules, such as LPA, S1P, and SPC, the physiological concentrations of LPC in body fluids, including blood and ascites, are very high (5–180 μM) [11,35–37] (our unpublished results). In addition, LPC may lyse cells at high concentrations (>30 μM) [38] due to its detergent like properties. Although numerous lines of evidence have been accumulated against a simple nonspecific membrane-damaging effect of LPC, and transmembrane signal transduction induced by LPC has been studied in many cellular systems, it was thought that a specific membrane

LPC may not exist [33,39]. In fact, if all of the LPC was all in an active form that could to interact with its receptors, all LPC receptors would be saturated and/or downregulated.

This puzzle may be addressed in several ways. In their recent "Perspective" article, Carson and Lo [40] have linked the concept of LPC compartmentalization to the LPC receptor. Different concentrations of LPC present in various cellular and tissue systems (i.e., different LPC compartmentations) may regulate cellular functions differentially. In addition, LPC in plasma is present mainly in albumin- and lipoprotein-bound forms [11]. These forms may be active in some nonreceptor-mediated functions of LPC, such as delivery of fatty acids and cholines [11], but may be in an unavailable form for receptor activation. It has been shown that serum proteins neutralize the toxic effects of LPC [41]. We have shown that in the presence of molar excesses of bovine serum albumin (BSA), the ability of LPC to elicit an increase in $[\text{Ca}^{2+}]_i$ through its receptor, GPR4, was greatly diminished [23]. Thus, the functionally available concentrations of LPC in vivo and the activation of LPC receptors may be controlled by a balance between different forms of LPC, including the free form, the albumin-bound form, other lipoprotein-bound forms and/or potentially unidentified forms. Receptor expression regulated by physiological and pathological conditions would also play an important role in controlling LPC-induced effects. A wide variety of signals, including DNA-damaging reagents and stress, activate G2A expression [20].

In most previous biological and signaling studies of LPC, >10 μM of LPC was used. In addition, various forms of LPC have been used, including LPC without carriers and BSA-bound and lipoprotein-associated LPC. Characterization of OGR1 subfamily receptors suggests that these receptors respond to LPC and SPC in the range of 1 nM to 10 μM , and lipids at >10 μM appear to have declining activities (unpublished results). In addition, when BSA is present at molar excess, LPC and SPC seem to have diminished abilities to activate receptor-mediated effects [23]. Whether the effects of LPC elicited at high concentrations (>30 μM) and/or in the bound forms are mediated through receptors remains to be further investigated.

The biological effects and the signaling properties of LPC have been most extensively studied in vitro in cells related to atherosclerosis, including endothelial cells, smooth muscle cells, monocytes, and lymphocytes (see review articles in Refs. [12,33,39]). LPC activates PLC [35] and PKC [33], induces increases in $[\text{Ca}^{2+}]_i$ [35,42], and activates or inhibits MAP kinase [43,44]. LPC has been demonstrated to be atherogenic. However, antiatherogenic actions of LPC have also been reported [39]. It will be important to determine whether this "dual" function of LPC is related to (a) receptor-mediated vs. nonreceptor-mediated effects, (b) LPC and receptor compartmentalization, and/or (c) LPC effects mediated via different types of proteins/receptors. The endogenous expression of G2A and GPR4 in these cell types remains to be determined. Nevertheless, the identifica-

tion of G-protein-coupled receptors for LPC has brought a new opportunity to study these effects and signaling pathways of LPC in the context of its receptors.

8. The possibilities that other receptors function as receptors for LPC and SPC and other lipid molecules function as ligands for OGR1 subfamily receptors

LPC has been shown to activate cellular responses in a PAF receptor-dependent manner [42,45,46]. However, our studies have shown that LPC and SPC are not able to induce an increase in calcium through the endogenous PAF receptor in parental MCF10A cells [21–23]. Therefore, it is unlikely that the increase in calcium induced by LPC was mediated by the PAF receptor. This is further confirmed by using three PAF-receptor-specific antagonists: BN52021, WEB-2170, and WEB-2086 [21–23]. Similarly, SPC- and LPC-induced receptor internalization is insensitive to PAF-receptor antagonists [21–23]. However, the possibility that LPC and SPC activate receptors other than OGR1, G2A, and GPR4 does exist. In fact, SPC has been shown to be a low-affinity ligand for S1P₁, S1P₂, and S1P₃, which are high-affinity receptors for S1P, as assessed by functional studies and/or ligand-binding analyses [47,48]. However, high concentrations of SPC are required to activate S1P receptors. Moreover, contradictory observations have been reported to suggest that these receptors do not bind SPC and are not activated by SPC [49,50]. Similarly, activation of the PAF receptor by LPC requires high concentrations of LPC (5–25 μ M). Whether the PAF receptor represents a low-affinity receptor for LPC remains to be further investigated. The potential of TDAG8 as a receptor for SPC and/or LPC, in addition to psychosine, is appealing. It is also possible that these phospholipid receptors interact with each other (engaged in cross-talk) in certain cellular systems. The apparent involvement of other low affinity receptors, such as S1P or PAF receptors, in SPC and LPC signaling, may not be due to direct binding and activation.

TDAG8 has recently been shown to be a psychosine receptor [24]. Treatment of cultured cells expressing this receptor with psychosine or structurally related glycosphingolipids results in the formation of globoid, multinuclear cells [24]. Our studies which show a negative response to psychosine in calcium mobilization, ligand binding, and MAP kinase activation assays, using ≤ 1 μ M psychosine suggest that psychosine is unlikely to be a high-affinity ligand for OGR1, G2A, and GPR4 [23]. The question of whether psychosine is a low-affinity ligand for OGR1, G2A, or GPR4 remains to be answered.

9. The occurrence of SPC and LPC in biological fluids and tissues

An imbalance in sphingolipid metabolism underlies a number of human diseases, as recently reviewed by Prieschl

and Baumruker [51]. Increased levels of SPC have been found in patients with Niemann-Pick disease, resulting from a deficiency of sphingomyelinase activity [52–54]. The potential pathological role of SPC in this disease has been suggested by its deleterious effect on mitochondrial function and calcium uptake [54]. Abnormally high levels of SPC have also been reported in the epidermis of patients with atopic dermatitis, due to abnormal expression of an SM deacylase, which generates SPC from SM [55]. The pathological effect of SPC in skin diseases has been suggested by its role in inflammatory processes of the epidermis through upregulation of intercellular adhesion molecule-1 and tumor necrosis factor- α [55,56].

The levels of LPC are elevated in many diseases related to inflammation [33,57]. More recently, elevated LPC levels (in particular, the ratios of palmitoyl-LPC to linoleoyl-LPC) have been reported in ovarian cancer [37] and multiple myeloma [58].

We have recently reported the detection of 20–200 nM SPC and 22–45 μ M of LPC in ascitic fluids from patients with ovarian cancer [59]. Importantly, the levels of SPC were significantly ($p=0.0011$) higher in ovarian cancer ascites than in ascites samples from patients with nonmalignant diseases, such as liver cirrhosis [59,60], suggesting that SPC may be involved in ovarian cancer development. Total LPC levels, on the other hand, were less significantly different in the two groups of patients (ovarian cancer vs. nonmalignant liver diseases). LPC has been shown to be involved in many inflammatory diseases, and inflammation is involved in both ovarian cancer and liver cirrhosis. Therefore, it may be physiologically relevant that ascitic LPC levels were similar from both groups.

LPA is a growth factor for ovarian cancer cells, but it also regulates their other functions [6,61–63]. Interestingly, ascites from patients with ovarian cancer contains a secreted lysophospholipase D-like activity, which converts LPC to LPA. When cell-free ovarian cancer ascites were incubated at 37 °C, the levels of LPC were decreased and the levels of LPA were increased within 24–72 h. This activity is sensitive to EDTA and EGTA treatment, suggesting the involvement of a calcium-dependent enzymatic activity was involved (our unpublished observations).

The levels and the biological activities of lyso-PLs are controlled by many factors, including enzymatic activities (for both production and degradation/conversion), cellular compartmentalization, and association with different proteins. Enzymatic activities are regulated by many extracellular stimuli. The metabolic pathways of glycerol-based phospholipids and sphingolipids are interlocked [64]. Phosphatidylcholine is the donor for the phosphorylcholine group in sphingomyelin synthesized from ceramide by sphingomyelinase [64]. The production and regulation of levels of SPC and LPC under physiological and pathological conditions remain to be further addressed in order to understand their pathophysiological roles. In addition, these investigations will provide an important basis for develop-

ing methods to control the levels of these lipids and to prevent their pathological functions in diseases.

10. Potential physiological roles of SPC/LPC receptors

Our understanding of the physiological roles of the OGR1 subfamily receptors is still preliminary, and the complexity of the potential roles of these receptors has already emerged. This complexity may be related to potential receptor redundancy in tissues, high concentrations of LPC in serum and plasma, and LPC compartmentalization. This review summarizes our knowledge to date and notes certain perspectives to be addressed in future studies.

The role of G2A in immunology has been revealed by *in vitro* studies [20,31,65] and, more importantly, studies in G2A-deficient mice [66]. G2A is expressed predominantly in lymphoid tissues [20,65]. G2A-knockout mice develop secondary lymphoid enlargement associated with abnormal expansion of both T and B lymphocytes. With age, these animals develop a late-onset autoimmune syndrome, suggesting that G2A functions as an immunosuppressor gene [66].

The potential role of G2A in tumor development appears to be complex. It suppresses the transformation potential of B lymphocytes (which expresses endogenous G2A) induced by BCR-ABL and other oncogenes [20]. In fibroblasts, G2A induces morphological transformation of NIH 3T3 fibroblasts, yet inhibits BCR-ABL-induced transformation of Rat-1 fibroblasts to become anchorage independent [20,31]. Zohn et al. [65] have suggested that G2A functions as an oncogenic receptor, based on their observation that G2A overexpression in NIH 3T3 cells induces a full range of phenotypes characteristic of oncogenic transformation. However, without actually showing the data on progressive tumor formation, whether the effects of G2A overexpression is more a morphological transformation or a true tumorigenic effect remains to be further addressed.

The tissue distributions of OGR1 subfamily genes are summarized in Table 4, based on published data from a number of laboratories and our own results. All four genes are expressed in more than one lymphoid tissue. GPR4 showed the highest expression in ovary, liver, lung, kidney, lymph node, and subthalamic nucleus, but not in other tissues, including some areas of the brain, colon, bladder, uterus, stomach, pancreas, salivary gland, mammary gland, peripheral blood leukocytes, fetal brain, and fetal heart [18,23]. OGR1 is expressed at high levels in the placenta, spleen, testis, small intestine, and peripheral leukocytes, but is not expressed in the liver, kidney, or ovary [15,18]. As two high-affinity receptors for SPC, OGR1 and GPR4 may play both overlapping and distinct physiological and pathological roles. G2A and TDAG8 are expressed predominantly in lymphoid tissues.

OGR1 subfamily receptors may belong to a subfamily of receptors that respond to stress and/or death-related signals. For example, the bovine homolog of OGR1, bRGR, is

Table 4

Gene expression of OGR1 and related receptors in human tissues

	OGR1	GPR4	G2A	TDAG8
Heart	+	++	+	–
Brain	++	+ (subthalamic nucleus)		–
Placenta	+++	++++		–
Lung	++++	++++	+	++
Liver	–	++++		+
Skeletal muscle	–	++++		–
Kidney	+/-	++++		++
Pancreas	–	–		–
Spleen	++++	++	+++	+++
Thymus	+	+	+++	++
PBL	++	–		++++
Lymph node		+++		+++
Bone marrow		+		+
Prostate	+	++		–
Testis	+++	++		+
Ovary	–	+++		–
Small intestine	++	+		+
Colon	–	+		–

The relative expression levels of OGR1 and related genes in different human tissues are expressed by “+” (positive expression), and “–” (negative expression), and the number of “+” is correlated with the relative expression levels. Data from Refs. [15,17,18,20,24]. PBL: peripheral blood lymphocytes.

upregulated during amino acid depletion [67]. These receptors may also induce cell death and/or apoptosis themselves. We have observed that overexpression of OGR1 in HEK 293 cells induces apoptosis (unpublished data). G2A is a DNA damage- and stress-inducible GPCR, which blocks cells in the G2/M phase of the cell cycle [20]. TDAG8 was isolated as an upregulated gene during activation-induced apoptosis in T cells [16,17]. Interestingly, three of these genes (OGR1, TDAG8, and G2A) are located on chromosome 14q31–32, a region which is known to be associated with ovarian cancer predisposition and progression through loss of heterozygosity [68], and where abnormalities are frequently found in human T cell leukemias and lymphomas [17,20].

The potential role of OGR1 as a tumor suppressor is suggested by a number of observations. Although OGR1 was originally cloned from ovarian cancer cells, we later found that OGR1 is expressed in only 2 of 10 ovarian cancer cell lines and 2 of 7 ovarian tumor tissue samples tested using RNase protection analysis. More importantly, one of the ovarian tissue samples appeared to express a mutant form of OGR1, since the protected fragment was about 30 nucleotides shorter than that from wild-type OGR1 (unpublished results). OGR1 mediates growth inhibition induced by SPC, as described above. These data, together with OGR1's genomic location (chromosome 14q31–32, a location potentially involved with ovarian cancer predisposition [68] and abnormalities in T cell leukemias and lymphomas [31]), suggest that OGR1 may function as a tumor suppressor.

11. Future directions

Determination of the pathophysiological functions of SPC, LPC, and their receptors is of primary importance. These factors are likely to be involved in many important biological systems and processes, such as brain biology, cardiovascular systems, immunology, inflammation, and cancer.

The signaling mechanisms (in particular, receptor-mediated signal transduction of SPC and LPC) have not been studied extensively, compared to studies on LPA and S1P, which are prototypes of lipid signaling molecules. The identification of LPC/SPC receptors has clearly formed a basis for the future understanding of the role and signaling mechanisms of these lipids in biological systems.

Acknowledgements

I thank the many members of my laboratory, especially Drs. Kui Zhu, Yi-jin Xiao, Guiying Hong, and Linnea Baudhuin for their contributions to the studies described in this review. I would also like to thank Dr. Owen Witte and the members of his laboratory, Drs. Kabarowski, Weng, and Lo for their contributions to the work described in this article. This work was supported in part by the American Cancer Society Grant RPG-99-062-01-CNE, the NIH grant R21 CA84038-01, and the US Army grant RPG-99-062-01-CNE to YX.

References

- [1] M. Liscovitch, L.C. Cantley, *Cell* 77 (1994) 329–334.
- [2] W.H. Moolenaar, *Ann. N. Y. Acad. Sci.* 905 (2000) 1–10.
- [3] S. Spiegel, S. Milstien, *J. Membr. Biol.* 146 (1995) 225–237.
- [4] N.N. Desai, R.O. Carlson, M.E. Mattie, A. Olivera, N.E. Buckley, T. Seki, G. Brooker, S. Spiegel, *J. Cell Biol.* 121 (1993) 1385–1395.
- [5] T. Yamada, F. Okajima, S. Ohwada, Y. Kondo, *Cell. Mol. Life Sci.* 53 (1997) 435–441.
- [6] Y. Xu, X.J. Fang, G. Casey, G.B. Mills, *Biochem. J.* 309 (1995) 933–940.
- [7] H. Wakita, K. Matsushita, K. Nishimura, Y. Tokura, F. Furukawa, M. Takigawa, *J. Invest. Dermatol.* 110 (1998) 253–258.
- [8] K.N. Bitar, H. Yamada, *Am. J. Physiol.* 269 (1995) G370–G377.
- [9] L. Sun, L. Xu, F.A. Henry, S. Spiegel, T.B. Nielsen, *J. Invest. Dermatol.* 106 (1996) 232–237.
- [10] G. Boguslawski, D. Lyons, K.A. Harvey, A.T. Kovala, D. English, *Biochem. Biophys. Res. Commun.* 272 (2000) 603–609.
- [11] M. Croset, N. Brossard, A. Polette, M. Lagarde, *Biochem. J.* 345 (2000) 61–67.
- [12] G.M. Chisolm III, Y. Chai, *Free Radical Biol. Med.* 28 (2000) 1697–1707.
- [13] G. Murugesan, P.L. Fox, *J. Clin. Invest.* 97 (1996) 2736–2744.
- [14] T. Yokota, G.K. Hansson, *J. Intern. Med.* 238 (1995) 479–489.
- [15] Y. Xu, G. Casey, *Genomics* 35 (1996) 397–402.
- [16] J.W. Choi, S.Y. Lee, Y. Choi, *Cell. Immunol.* 168 (1996) 78–84.
- [17] H. Kyaw, Z. Zeng, K. Su, P. Fan, B.K. Shell, K.C. Carter, Y. Li, *DNA Cell Biol.* 17 (1998) 493–500.
- [18] S. An, C. Tsai, E.J. Goetzl, *FEBS Lett.* 375 (1995) 121–124.
- [19] M. Heiber, J.M. Docherty, G. Shah, T. Nguyen, R. Cheng, H.H. Heng, A. Marchese, L.C. Tsui, X. Shi, S.R. George, *DNA Cell Biol.* 14 (1995) 25–35.
- [20] Z. Weng, A.C. Fluckiger, S. Nisitani, M.I. Wahl, L.Q. Le, C.A. Hunter, A.A. Fernal, M.M. Le Beau, O.N. Witte, *Proc. Natl. Acad. Sci. U.S.A.* 95 (1998) 12334–12339.
- [21] Y. Xu, K. Zhu, G. Hong, W. Wu, L.M. Baudhuin, Y. Xiao, D.S. Damron, *Nat. Cell Biol.* 2 (2000) 261–267.
- [22] J.H. Kabarowski, K. Zhu, L.Q. Le, O.N. Witte, Y. Xu, *Science* 293 (2001) 702–705.
- [23] K. Zhu, L. Baudhuin, G. Hong, F.S. Williams, K.L. Cristina, J.H.S. Kabarowski, O.N. Witte, Y. Xu, *J. Biol. Chem.* 276 (2001) 41325–41335.
- [24] D.S. Im, C.E. Heise, T. Nguyen, B.F. O'Dowd, K.R. Lynch, *J. Cell Biol.* 153 (2001) 429–434.
- [25] D. Diviani, A.L. Lattion, S. Cotecchia, *J. Biol. Chem.* 272 (1997) 28712–28719.
- [26] P. Casas-Gonzalez, J. Vazquez-Prado, J.A. Garcia-Sainz, *Mol. Pharmacol.* 57 (2000) 1027–1033.
- [27] N.N. Desai, S. Spiegel, *Biochem. Biophys. Res. Commun.* 181 (1991) 361–366.
- [28] Y. Tokura, H. Wakita, N. Seo, F. Furukawa, K. Nishimura, M. Takigawa, *J. Invest. Dermatol. Symp. Proc.* 4 (1999) 184–189.
- [29] K. Sekiguchi, T. Yokoyama, M. Kurabayashi, F. Okajima, R. Nagai, *Circ. Res.* 85 (1999) 1000–1008.
- [30] Y. Xu, G. Casey, G.B. Mills, *J. Cell. Physiol.* 163 (1995) 441–450.
- [31] A.J. Lusis, *Nature* 407 (2000) 233–241.
- [32] J.H. Kabarowski, J.D. Feramisco, L.Q. Le, J.L. Gu, S.W. Luoh, M.I. Simon, O.N. Witte, *Proc. Natl. Acad. Sci. U.S.A.* 97 (2000) 12109–12114.
- [33] N.V. Prokazova, N.D. Zvezdina, A.A. Korotaeva, *Biochemistry (Moscow)* 63 (1998) 31–37.
- [34] M. Kohno, K. Yokokawa, K. Yasunari, M. Minami, H. Kano, T. Hanehira, J. Yoshikawa, *Circulation* 98 (1998) 353–359.
- [35] F. Okajima, K. Sato, H. Tomura, A. Kuwabara, H. Nochi, K. Tamoto, Y. Kondo, Y. Tokumitsu, M. Ui, *Biochem. J.* 336 (1998) 491–500.
- [36] T. Sasagawa, K. Suzuki, T. Shiota, T. Kondo, M. Okita, *J. Nutr. Sci. Vitaminol. (Tokyo)* 44 (1998) 809–818.
- [37] M. Okita, D.C. Gaudette, G.B. Mills, B.J. Holub, *Int. J. Cancer* 71 (1997) 31–34.
- [38] K. Jalink, E.J. van Corven, W.H. Moolenaar, *J. Biol. Chem.* 265 (1990) 12232–12239.
- [39] S. Hara, T. Shike, N. Takasu, T. Mizui, *Arterioscler., Thromb., Vasc. Biol.* 17 (1997) 1258–1266.
- [40] M.J. Carson, D. Lo, *Science* 293 (2001) 618–619.
- [41] M. Mochizuki, J.S. Zigler Jr., P. Russell, I. Gery, *Curr. Eye Res.* 2 (1982–83) 621–624.
- [42] T. Ogita, Y. Tanaka, T. Nakaoka, R. Matsuoka, Y. Kira, M. Nakamura, T. Shimizu, T. Fujita, *Am. J. Physiol.* 272 (1997) H17–H24.
- [43] B.V. Bassa, D.D. Roh, N.D. Vaziri, M.A. Kirschenbaum, V.S. Kamanana, *Am. J. Physiol.* 277 (1999) F328–F337.
- [44] Y. Rikitake, S. Kawashima, T. Yamashita, T. Ueyama, S. Ishido, H. Hotta, K. Hirata, M. Yokoyama, *Arterioscler., Thromb., Vasc. Biol.* 20 (2000) 1006–1012.
- [45] A. Gomez-Munoz, L. O'Brien, R. Hundal, U.P. Steinbrecher, *J. Lipid Res.* 40 (1999) 988–993.
- [46] Y.H. Huang, L. Schafer-Elinder, R. Wu, H.E. Claesson, J. Frostegard, *Clin. Exp. Immunol.* 116 (1999) 326–331.
- [47] H. Okamoto, N. Takuwa, Y. Yatomi, K. Gonda, H. Shigematsu, Y. Takuwa, *Biochem. Biophys. Res. Commun.* 260 (1999) 203–208.
- [48] J.R. van Brocklyn, Z. Tu, L.C. Edsall, R.R. Schmidt, S. Spiegel, *J. Biol. Chem.* 274 (1999) 4626–4632.
- [49] S. An, T. Bleu, W. Huang, O.G. Hallmark, S.R. Coughlin, E.J. Goetzl, *FEBS Lett.* 417 (1997) 279–282.
- [50] G.C. Zondag, F.R. Postma, I.V. Ethen, I. Verlaan, W.H. Moolenaar, *Biochem. J.* 330 (1998) 605–609.
- [51] E.E. Prieschl, T. Baumruker, *Arch. Immunol. Ther. Exp. (Warsz.)* 48 (2000) 163–171.
- [52] A. Berger, D. Rosenthal, S. Spiegel, *Proc. Natl. Acad. Sci. U.S.A.* 92 (1995) 5885–5889.

- [53] C. Rodriguez-Lafrasse, M.T. Vanier, *Neurochem. Res.* 24 (1999) 199–205.
- [54] P.M. Strasberg, J.W. Callahan, *Biochem. Cell Biol.* 66 (1988) 1322–1332.
- [55] Y. Murata, J. Ogata, Y. Higaki, M. Kawashima, Y. Yada, K. Higuchi, T. Tsuchiya, S. Kawainami, G. Imokawa, *J. Invest. Dermatol.* 106 (1996) 1242–1249.
- [56] G. Imokawa, Y. Takagi, K. Higuchi, H. Kondo, Y. Yada, *J. Invest. Dermatol.* 112 (1999) 91–96.
- [57] A.A. Murphy, N. Santanam, A.J. Morales, S. Parthasarathy, *J. Clin. Endocrinol. Metab.* 83 (1998) 2110–2113.
- [58] T. Sasagawa, M. Okita, J. Murakami, T. Kato, A. Watanabe, *Lipids* 34 (1999) 17–21.
- [59] Y.J. Xiao, B. Schwartz, M. Washington, A. Kennedy, K. Webster, J. Belinson, Y. Xu, *Anal. Biochem.* 290 (2001) 302–313.
- [60] Y. Xu, Z. Shen, D.W. Wiper, M. Wu, R.E. Morton, P. Elson, A.W. Kennedy, J. Belinson, M. Markman, G. Casey, *JAMA* 280 (1998) 719–723.
- [61] B.M. Schwartz, G. Hong, B.H. Morrison, W. Wu, L.M. Baudhuin, Y.J. Xiao, S.C. Mok, Y. Xu, *Gynecol. Oncol.* 81 (2001) 291–300.
- [62] Y. Xu, Y.J. Xiao, L.M. Baudhuin, B.M. Schwartz, *J. Soc. Gynecol. Invest.* 8 (2001) 1–13.
- [63] X. Fang, D. Gaudette, T. Furui, M. Mao, V. Estrella, A. Eder, T. Pustilnik, T. Sasagawa, R. Lapushin, S. Yu, R.B. Jaffe, J.R. Wiener, J.R. Erickson, G.B. Mills, *Ann. N. Y. Acad. Sci.* 905 (2000) 188–208.
- [64] S. Pyne, N.J. Pyne, *Biochem. J.* 349 (2000) 385–402.
- [65] I.E. Zohn, M. Klinger, X. Karp, H. Kirk, M. Symons, M. Chrzanowska-Wodnicka, C.J. Der, R.J. Kay, *Oncogene* 19 (2000) 3866–3877.
- [66] L.Q. Le, J.H. Kabarowski, Z. Weng, A.B. Satterthwaite, E.T. Harvill, E.R. Jensen, J.F. Miller, O.N. Witte, *Immunity* 14 (2001) 561–571.
- [67] A. Ferrer-Martinez, A. Felipe, J.F. Mata, F.J. Casado, M. Pastor-Anglada, *Biochem. Biophys. Res. Commun.* 238 (1997) 107–112.
- [68] C.A. Bandera, H. Takahashi, K. Behbakht, P.C. Liu, V.A. LiVolsi, I. Benjamin, M.A. Morgan, S.A. King, S.C. Rubin, J. Boyd, *Cancer Res.* 57 (1997) 513–515.
- [69] R.D. Ye, E.R. Prossnitz, A.H. Zou, C.G. Cochrane, *Biochem. Biophys. Res. Commun.* 180 (1991) 105–111.
- [70] Z. Honda, M. Nakamura, I. Miki, M. Minami, T. Watanabe, Y. Seyama, H. Okado, H. Toh, K. Ito, T. Miyamoto, *Nature* 349 (1991) 342–346.

Unfolding the pathophysiological role of bioactive lysophospholipids

Yan Xu*, Yi-jin Xiao, Kui Zhu, Linnea M. Baudhuin, Jun Lu, Guiying Hong, Kwan-sik Kim, Kelly
L. Cristina, Li Song, Freager S. Williams, Paul Elson, and Jerome Belinson

Department of Cancer Biology, The Lerner Research Institute, Cleveland Clinic Foundation, 9500
Euclid Avenue, Cleveland, OH, 44195 (Y.X., Y-j. X., K.Z., L.M.B., J.L., G.H., K.-s. K., K.L.C., and
L.G.), Department of Gynecology and Obstetrics, Cleveland Clinic Foundation, 9500 Euclid
Avenue, Cleveland, OH, 44195 (Y.X., F.S.W., and J.B.), The Taussig Cancer Center, Cleveland
Clinic Foundation, 9500 Euclid Avenue, Cleveland, OH, 44195 (Y.X. P.E., and J.B.), Department of
Chemistry, Cleveland State University, Euclid and East 24th Street, Cleveland, OH, 44115 (L.M.B.,
Y.X.),

*Address correspondence to this author at the Department of Cancer Biology, Cleveland Clinic
Foundation, 9500 Euclid Avenue, Cleveland, OH, 44195. e-mail: xuy@ccf.org

Abstract: Lysophospholipids (LPLs), including glycerol- and sphingoid-based lipids, stimulate cell signaling and potentially play important pathophysiological roles in humans and other animals. These LPLs include lysophosphatidic acid (LPA), lysophosphatidylcholine (LPC), lysophosphatidylserine (LPS), sphingosine-1-phosphate (S1P), and sphingosylphosphorylcholine (SPC). Analyses of LPLs in human body fluids from subjects with different pathophysiological conditions reveal not only the relevance of LPLs in human diseases, but also their potential application as biomarkers and/or therapeutic target. In recent years, the identification and/or characterization of the plasma membrane receptors for LPLs and enzymes regulating the metabolism of LPLs have greatly facilitated our understanding of their role and signaling properties. *In vitro* and *in vivo* functional and signaling studies have revealed the broad and potent biological effects of LPLs and the mechanisms of LPL actions in different cellular systems. Development of specific antagonists for each of the LPL receptors will provide powerful tools for dissecting signaling pathways mediated by receptor subtypes. More importantly, these antagonists may serve as therapeutics for relevant diseases. Genetic depletion of LPL receptors in mice has provided and will continue to provide critical information on the pathophysiological roles of LPL receptors. It is important to further evaluate the significance of targeting these bioactive LPL receptors, their downstream signaling molecules, and/or metabolic enzymes in the treatment of cancers and other diseases.

Key words: lysophospholipids (lyso-PLs), lysophosphatidic acid (LPA), sphingosine-1-phosphate (S1P), sphingosylphosphorylcholine (SPC), lysophosphatidylinositol (LPI), lysophosphatidylcholine (LPC), ovarian cancer, G protein coupled receptors (GPCRs)

For several decades, LPLs were known as precursors/intermediates of lipid biosynthesis, and/or components of the plasma membrane. Although the effects of LPA on blood pressure and platelet aggregation has long been recognized [1,2], the evidence for LPA as a first messenger and its signaling properties were only clearly demonstrated in the late 1980s and early 1990s [3-6]. During the same period, SIP was also recognized as a cell-signaling molecule [7,8]. These pioneering publications have led to a rapid growth in the field, which is reflected in part by the steadily increasing numbers of publications related to bioactive LPLs [9].

The cellular responses to LPA are very broad, ranging from chemotaxis in *Dityostelium* amoebae, cell differentiation, proliferation, apoptotic protection in many cell types, platelet aggregation, smooth muscle contraction, to tumor cell invasion [10]. Other LPLs also have broad cellular effects. However, the degree to which these tested effects are pathophysiologically relevant is unclear.

Unfolding the pathophysiological roles of LPLs has taken several directions in the past few years: 1) the determination of lipid content under different pathophysiological conditions and the potential correlation between the levels of LPLs and their functions; 2) the identification of enzymes/proteins involved in the metabolism and transport of LPLs; 3) signaling and functional studies under pathophysiologically relevant conditions; 4) the development of specific antagonists to block the biological effects and signaling pathways of LPLs; and 5) the determination of LPL receptor functions through genetic manipulation. Several reviews have addressed the recent progress of many of these aspects [11-28]. The entire issue of *Biochim. Biophys. Acta*, 1582 (2002) is devoted to address the role and signaling of LPLs in a variety of cellular systems, including

neurological, cardiovascular, angiogenic, inflammatory, immunological, and oncogenic systems.

This review discusses some aspects related to the first three identified areas listed above.

LIPID ANALYSES AND THE PATHOPHYSIOLOGICAL RELEVANCE

To address the pathophysiological relevance of LPLs, it is critically important to obtain information on physiological levels of these LPLs in animal tissues and cellular systems under investigation. However, most LPLs are poor in UV/visible absorbance and therefore normal UV/visible detectors are incapable of detecting these LPLs. Classical gas chromatography requires esterization of fatty acids derived from LPLs, which is time consuming, and inaccuracies can be easily introduced into the measurement. In addition, a number of LPLs, such as lysosphingolipids and ether-linked glycolysophospholipids, do not contain esterifiable fatty acid. Moreover, LPLs compose less than 5% of total phospholipids. In particular, LPA and S1P, the two most potent signaling LPLs, are present in body fluids and cellular systems in the nM to low μ M range, and thus it is difficult to detect their levels accurately.

A number of biological methods to analyze LPA and/or S1P have been developed recently [26,29-36]. These methods are dependent on either a biological activity of the lipid, or an enzymatic activity converting the lipid to a photometrically/radioactively detectable substance. While these methods are usually convenient to conduct, they may suffer from a number of shortcomings. First, they may not be sensitive enough to detect a pM range of lipids, which is essential for identifying low levels of LPLs in small volumes of body fluids or cell culture supernatants. Second, these methods cannot detect different molecular species of LPLs, such as LPAs with varying fatty acid side chains. Third, the results may be influenced by endogenous factors, which affect either the biological activity of the lipid or the enzymatic activity converting the lipid. Finally, the activity of

batch-to-batch preparations of the converting enzyme may vary. An ideal method to detect lipids is antibody-based. However, LPLs are generally not antigenic and it is very difficult to raise specific antibodies against these lipids. Although a few such antibodies have been developed or detected in human/animal serum [37-42], the clinical and research utilities of these antibodies remain to be seen.

Methods of LPL analyses using mass spectrometry have been developed in the past a few years [43-52]. In particular, we have developed a highly sensitive, reproducible, and quantitative method to analyze all major LPLs simultaneously [53,54]. Using this mass spectrometry-based method, we have shown that a variety of LPLs are present in human body fluids [53,54]. Some of these LPLs, and in particular, the different molecular species of LPA, are elevated in patients with ovarian cancer [53-55]. Our preliminary results show that LPA levels are not elevated in plasma from patients with leukemias; or breast, prostate, and renal cancers, indicating that the elevation of particular LPLs is cancer type- and disease-specific [55](Xiao and Xu, unpublished results).

Elevated LPA levels have also been reported in renal dialysis patients and patients with multiple myeloma [56, 57]. Elevated levels and altered fatty acid composition of plasma LPC have been reported in ovarian cancer patients [57]. Increased levels of LPA may also be associated with other non-malignant pathological conditions. Our preliminary results also suggest that LPA levels were elevated from patients with type II diabetes, compared to healthy controls (3.2 ± 0.2 versus $0.6 \pm 0.4 \mu\text{M}$; $n=6$ in each group). After a program that reduced energy uptake, which lowered blood glucose levels by 33%, the mean LPA level was significantly reduced by 37% (Annamaria B Manodori, Yi-jin Xiao, and Yan Xu, unpublished results). Table 1 summarizes different LPL contents in plasma and ascites from patients with ovarian cancer, non-malignant diseases or healthy female controls.

Several general notions may be derived from the data shown in Table 1 and other published data. First, although there is a relatively wide range of individual variations in levels and molecular species within any group of human subjects, elevated LPLs are significantly associated with certain human diseases. Second, levels of most negatively charged LPLs, including different molecular species of LPA and LPI, are higher in ovarian cancer ascites, compared to those in plasma from the same patients, suggesting that these elevated LPLs are locally produced by tumor cells and/or produced in a tumor cell-regulated fashion. In contrast, the blood levels of LPC, SPC, and sphingomyelin are similar or higher than those of ascites, suggesting that the main source(s) of blood LPC and SPC may not be tumor related. This is consistent with our knowledge about the production of LPC, which takes place mainly in the liver [59]. Third, both LPA and S1P have been shown to be produced by activated platelets [60-64]. Contribution of platelet-derived LPA in total blood LPA levels is consistent with observations that serum (where platelets are activated) levels of LPA are higher than that in plasma (where platelets are not activated and most of them are removed by centrifugation) from same subjects [65]. However, we did not observe higher S1P levels in serum versus plasma (our unpublished data). These results suggest that other source(s) may contribute to S1P production and/or degradation in blood. Fourth, comparisons among molecular species of LPA, LPI, and LPC in ascites versus blood suggests that while the predominant species of LPC and LPI are similar in both ascites and plasma, there are differences with respect to LPA both in terms of the predominant molecular species present and the distribution of species. 16:0-LPC was the predominant LPC species in both ascites and plasma. 16:0 or 18:0-LPI was the predominant LPI species in both fluids. In contrast, while 16:0 or 18:0-LPA was the predominant LPA species in the plasma of most ovarian cancer patients, approximately 50% patients had other LPA species as the predominant species in their ascitic fluids (our unpublished results). We noted that LPS, which

appears to have specific effects on mast cells, T cells and neural cells [66-68] was not detected in blood or ascites samples from healthy controls (both male and female) and patients with ovarian, breast, or prostate cancer.

Recently, work by Baker et al did not observe differences between LPA levels in plasma from patients with ovarian cancer and controls [69]. The basis of the discrepancies between studies needs to be further investigated. The realization has come forth that a number of issues need to be more carefully addressed in LPL analyses. Unlike protein/peptide markers, LPLs are metabolites. The levels of these lipids may change during sample collection and processing. Thus, particular cautions are required during sample collection and processing. The use of proper glass/plastic ware for processing LPLs is critical. The most commonly used plastic ware may bind $\geq 90\%$ of LPA and other negatively charged LPLs (our unpublished results). Thus, glass and siliconized plastic ware are highly recommended for lipid processing. In order to effectively compare results from different studies, "standard" collection and analytical methodologies for LPLs need to be developed or accepted. Development of a high throughput method for lipid analysis is essential for its clinical applications. Recently developed chip-based mass spectrometry methods, such as surface-enhanced laser desorption and ionization (SELDI), are highly appealing.

LPL METABOLISM AND TRANSPORT

Our understanding of LPL synthesis and the mechanisms of extracellular LPL generation are still limited. In particular, there is little information on how intracellularly synthesized LPA and S1P are released from cells. A number of recent review papers have described the synthesis and release of LPA and S1P, and enzymes involved in metabolism of LPA and S1P [21-24].

G protein coupled receptors (GPCRs) for LPLs [70,71] can transport their ligand when they are activated and internalized. In addition, a number of LPA transporters or binding proteins have been identified [12,21]. The yeast oligomycin resistance gene, a member of the ATP binding cassette family of proteins is involved in transporting S1P [72]. The cystic fibrosis transmembrane regulator (CFTR) is involved in the uptake of S1P and LPA, but not sphingosine, C(16)-ceramide, sphingomyelin, SPC, phosphatidylcholine, LPC, or phosphatidic acid [72]. Whether these or additional transporters are directly involved in LPA and S1P release remains to be determined.

Interestingly, more data have been accumulating to show that both LPA and S1P can be produced directly extracellularly. LPA can be produced by secretory phospholipase 2 (sPLA2) [73]. Ancellin et al. have shown recently that sphingosine kinase-1, the enzyme that catalyzes the formation of S1P, can be constitutively exported by endothelial cells and thus S1P can be synthesized extracellularly [74].

Perhaps the most exciting development in LPL synthesis is the recent identification of the first mammalian lysophospholipase D (lyso-PLD) [75-77]. Although Tokumura and his co-worker observed the lysoPLD activity in plasma as early as 1986 [78-81], this enzyme has only recently been identified. Quite surprisingly, the mammalian lysoPLD is a previously known protein, autotaxin, which is a cell motility-stimulating ecto-phosphodiesterase. Importantly, the soluble form of this lysoPLD, a proteolytic cleavage product of the membrane bound enzyme, is active and capable of producing extracellular LPA from LPC [75-77].

Under physiological conditions, LPC is mainly secreted by the liver and circulated at high concentrations in plasma (12-166 μ M; Table 1). The concentrations of LPA in plasma from healthy subjects are much lower, when compared to LPC (Table 1 and [63]), suggesting that the conversion of LPC to LPA must be tightly controlled. The regulatory mechanisms of lysoPLD, at either

expression or activity level, are unknown. How much of this lysoPLD activity accounts for the amount of the LPA present in plasma remains to be determined. We have observed that when ascites from patients with ovarian cancer were incubated at 37°C, LPA levels were increased, and LPC levels were decreased, suggesting a lysoPLD activity is present in human ovarian cancer ascites (our unpublished results). It will be highly interesting to determine whether lysoPLD is the major enzyme responsible for the elevated LPA levels observed in ovarian cancer ascites. Furthermore, since LPC is significantly involved in atherosclerosis, it will be intriguing to determine whether there is a relationship between lysoPLD activity and heart disease.

SIGNALING AND FUNCTIONAL STUDIES UNDER PATHOPHYSIOLOGICAL RELEVANT CONDITIONS

Elevated LPA levels in blood and ascites of patients with ovarian cancer suggest that LPA plays a role in ovarian cancer initiation and/or development. The cellular effects of LPA in ovarian cancer cells have been recently reviewed [25,26,82]. To understand the potential role of LPLs present in ascites on ovarian cancer cell proliferation, we tested the effects of LPLs detected in ovarian cancer ascites in a panel of human cancer cell lines, including 6 ovarian cancer cell lines (HEY, OCC1, SKOV3, ovca420, ovca429, and ovca432), five breast cancer cell lines (MCF7, T47D, MDA-MB-231, MDA-MD-435, and MDA-MB-453), and four prostate cancer cell lines (PC-3, LnCap, PC2-4, and DU145). In addition, we have included in our studies two non-malignant cell lines: MCF10A, an immortalized breast cell line [83], and an immortalized human microvascular endothelial cell line HMEC-1 [84]. The results from Swiss 3T3 cells are also included for comparison (Table 2). The concentration of all lipids used ranged from 0.1 μ M to 10 μ M. All

results in Table 2 are presented as % of thymidine incorporation compared with controls in the same cell line.

LPA (including ether-linked LPAs)

In general, physiological concentrations of LPA (1-10 μ M) are growth stimulatory in malignant cells. Among three types of cancer cells (ovarian, breast, and prostate), ovarian cancer cells appear to be more responsive to the proliferative effect of LPA, although the selection of cell lines tested may have biased the results observed. In contrast, LPA does not induce DNA synthesis in the two non-malignant human cell lines (MCF10a and HMEC). In fact, the proliferation of HMEC cells were approximately 50% inhibited by LPA (1-10 μ M), assessed by the MTT dye reduction assays (our unpublished results). Normal ovarian surface epithelial cells do not respond to LPA [26,85]. These results suggest that some, but not all, cancer cells, have acquired an increased responsiveness to LPA. LPA also protects cells from apoptosis [86,87], and modulates cell adhesion and migration [88-91]. LPA induces pro-angiogenic factors, such as interleukin-8 and vascular endothelial growth factor (VEGF) in ovarian cancer cells [85,91].

Different molecular species of LPA have different biological effects. 18:1-LPA is much more mitogenic than 16:0- and 18:0-LPAs in ovarian cancer cells [26,93,94]. Physiological concentrations of alkyl- and alkenyl-LPAs stimulate both DNA synthesis (measured by [3 H]thymidine incorporation) and cell proliferation (measured by MTT assays and cell count) [90]. Acyl- and ether-linked LPAs induce cell migration [90,95]. Interestingly, while the LPA-induced endothelial cell migration is mainly through chemokinetics, the ether-linked LPA-induced ovarian cancer cell migration is mainly chemotactic [90,95].

The signaling properties of LPLs were mainly studied in model cellular systems, such as fibroblasts [3,7,8,25]. The cellular responses and signaling mechanisms of LPA and S1P and their receptors have been recently reviewed [12-20,27,18]. We have recently reviewed the newly identified receptors for LPC and SPC [71].

For ovarian cancer cells, an upregulated PI3K-Akt signaling pathway is critically important in cancer development [26]. Using a Genechip technology, we identified Akt2 as one of the genes upregulated (3.5 to 4-fold) by both LPA (10 μ M) and S1P (1 μ M) in HEY ovarian cancer cells (our unpublished results). Mechanistic studies conducted in ovarian cancer cells revealed that PI3K is an upstream activator of both MAP kinase and Akt signaling pathways. The kinase activity and S473 phosphorylation of Akt induced by LPA (both acyl-LPAs and ether-linked LPAs) and S1P requires both mitogen-activated protein kinase kinase (MEK) and p38 MAP kinase, and MEK is likely to be upstream of p38, in HEY ovarian cancer cells. The requirement for both MEK and p38 is cell type- and stimulus-specific. Of importance, these studies have revealed that LPA and S1P induce interactions between a major cell proliferation signaling pathway (MEK/ERK) and a major cell survival pathway (PI3-K/Akt) in ovarian cancer cells. LPA/S1P-induced Akt activation may be involved in cell survival, since LPA and S1P treatment in HEY ovarian cancer cells results in a decrease in paclitaxel-induced caspase-3 activity in a PI3-K/MEK/p38-dependent manner [86,87].

S1P

We found recently that S1P was significantly increased in the blood of patients with ovarian cancer, when compared with patients with benign gynecological diseases (unpublished results). S1P (1 μ M) activates ERK and Akt in ovarian cancer cells. Pretreatment of S1P (1 μ M) reverses the apoptotic effect induced by paclitaxel [87]. S1P also induces the secretion of IL-8, a pre-angiogenic

factor [85]. In addition, S1P modulates adhesion and migration of ovarian cancer cells [91] (our unpublished data)

S1P stimulates DNA synthesis in many cellular systems [96], with the exception of some breast cancer cell lines (Table 2)[97]. It will be interesting to see whether the inhibitory effect in breast cancer cells is due to: 1) a relatively high expression of S1P₅, which mediates the anti-proliferative effect [96]; 2) a rapid conversion of S1P to sphingosine (which is growth-inhibitory) in these cells; and/or 3) the negative effect of S1P on cell attachment. S1P (1-20 μ M) inhibits adhesion, and consequently inhibits cell proliferation in certain cell types [91].

Physiological concentrations of S1P (< 1 μ M) were not effective in DNA synthesis in most of the cell lines tested (Table 2). Therefore, the physiological relevance of the effect of S1P on thymidine incorporation remains to be carefully examined. Moreover, receptors S1P₁₋₃ (Edg1,3,5), receptors for S1P, have been shown to be down-regulated, while LPA₂ (Edg4) and LPA₃ (Edg7), receptors for LPA, are elevated in ovarian cancer cells [26]. Thus, the role of S1P in ovarian cancer remains to be further explored.

LPI

The biological role of LPI has been reviewed recently [98]. LPI, but not LPA, stimulates insulin release in pancreatic islets [99]. LPI, but not LPC or LPE, has been shown to stimulate cell proliferation in differentiated and in K-ras transformed thyroid cells [100]. Elevated levels and mitogenic activity of LPI have been reported in k-ras-transformed epithelial cells and H-Ras-transformed fibroblasts [100]. However, as shown in Table 2, LPI (at physiologically relevant concentrations) inhibited mitogenesis in all 6 ovarian cancer cells tested, despite the fact that it was elevated in both ascites and plasma from patients with ovarian cancer. One of the explanations for

these observations is that the inhibitory effect of LPI is neutralized by albumin and/or other binding proteins in ascites. The effects of albumin and gelsolin on LPA activity have been discussed in a recent review by Goetzl [12]. We tested the effect of bovine serum albumin (BSA) on thymidine incorporation induced by LPLs. We found that 0.1% BSA (approximately 15 μ M) minimally affected (<20%) LPA- and S1P-regulated [3 H]thymidine incorporation in all 16 cell lines tested. In contrast, BSA blocked 80-100%, 70-90%, and 50-80% of the effects of LPC, LPI and SPC, respectively, regardless the effect was stimulatory or inhibitory (our unpublished results). LPI and LPC are present at high concentrations in ascites, where tumor cells grow. However, the presence of high concentrations of proteins, and albumin in particular, is likely to protect cells from the damaging effect of these lipids.

Several issues related to LPI remain to be investigated: 1) the pathophysiological role of LPI; 2) whether the cellular effects of LPI are mediated through cell membrane receptor(s); 3) the source and production of LPI; and 4) the main physical form (free or bound) of LPI in body fluids.

LPC

LPC is an important cellular component of oxidized low-density lipoprotein (ox-LDL). Its potential role in atherosclerosis and other inflammatory diseases have been reviewed recently [101-103]. The role of LPC in cancer is unclear. Elevated LPC has been detected in plasma from patients with ovarian cancer and endometriosis [58,104]. Although our studies show that the LPC levels in ascites from patients with ovarian cancer are significantly higher ($p=0.0025$) than levels from patients with benign diseases (mainly liver cirrhosis), the levels of LPC in ascites from individuals of either group are overlap significantly [54]. The mitogenic effect of LPC (measured by thymidine incorporation) is highly dependent on the cell type tested, the concentration range of LPC used, and

the molecular species of LPC investigated. In light of the recent identification of lyso-PLD [75-77], it will be highly interesting to determine whether converting LPC to LPA is one of the mechanisms involved in the cellular response to LPC for proliferation.

Many previous studies on LPC used concentrations of LPC ranging from 1 to 100 μM . Although up to 170 μM of LPC were detected in plasma of individuals (Table 1), the majority of LPC is in a bound form. Unlike LPA and S1P, which are active in the albumin-bound form for many of their biological effects and signaling capacities, the biological effects and signaling properties of LPC, LPI, and SPC may be strongly influenced by their physical forms (free versus bound) (see above). Due to the detergent nature of LPC, and a potential contaminant in some of the commercial LPC preparations[98], the effects of LPC, when used at high concentrations ($\geq 10 \mu\text{M}$) and tested in the absence of a carrier protein(s), need to be viewed with a caution. When tested in a serum-free medium, LPC was mitogenic at low concentrations ($\leq 1 \mu\text{M}$), and inhibitory at higher concentrations (3-10 μM) in a number of ovarian cancer cells. Whether any of these effects is mediated by recently identified LPC receptors remain to be tested [71,106,107]. Both of the stimulatory and the inhibitory effects of LPC can largely be reversed by BSA (see above). These observations are consistent with earlier reports about the neutralizing effect of serum proteins on LPC [108]. Human ovarian cancer ascites contains high concentrations of proteins (30-100 mg/ml). In particular, albumin concentrations are very high. Thus, the pathophysiological effect of LPC in ovarian cancer and other diseases need to be assessed under conditions that mimic *in vivo* situations.

SPC

SPC is an important bioactive molecule [109]. It has been shown to be involved in many cellular processes, such as proliferation or growth inhibition [90,110-114], smooth muscle

contraction and wound healing [115,116]. SPC stimulates wound healing in mice[116] and induces neurite outgrowth [117]. SPC activates a variety of signaling pathways, such as protein phosphorylation [118], MAPK [119], PKC [119,120], and calcium release or flux [93,121-124]. It also stimulates activator protein-1 (AP-1) binding [125] and induces intercellular adhesion molecule-1 (I-CAM-1) [126] and IL-6 expression [127].

SPC (1-10 μ M) is mitogenically inhibitory in most cancer cell lines tested and the inhibitory effect appear to be more pronounced in ovarian cancer cells, when compared to breast and prostate cancer cells (Table 2). However, it stimulates both DNA synthesis and/or cell proliferation in a number of non-malignant cell types [111,112,114,116,128,129], including the immortalized HMEC-1 cells (our unpublished results; Table 2). We have identified G protein coupled receptors for SPC and suggested the opposing effects of SPC on cell proliferation in different cell types may be regulated by different SPC receptors [71,106, 107,130]. In HEY cells, we found that overexpression of SPC receptors, OGR1 and GPR4, sensitized cellular response to low concentrations of SPC and LPC (unpublished data). These concepts need to be further confirmed by broad-spectrum studies in a variety of cellular systems. SPC may induce cell death through both apoptosis and necrosis (our unpublished results). SPC, as well as LPI, can also induce strong cellular morphological changes in many cell types (our unpublished observations).

The concentrations of SPC detected in blood and ascites (Table 1) are below 500 nM. Therefore, the pathological relevance of the effects of SPC (1-10 μ M) need to be further addressed. We have found that low concentrations of SPC and S1P (20-200 nM) synergize with LPA to stimulate the secretion of the proangiogenic factor, interleukin-8, from ovarian cancer cells [85]. In addition, increased levels of SPC have been found in patients with Niemann-Pick disease, resulting from a deficiency of sphingomyelinase activity [125,131,132]. Abnormally high levels of SPC have

also been reported in the epidermis of patients with atopic dermatitis, resulting from the abnormal expression of a sphingomyelin deacylase, which generates SPC from sphingomyelin [126,133].

FUTURE PERSPECTIVE

LPLs are actively involved in many cellular processes. Our understanding of the functions of LPLs in these processes and LPL signaling mechanisms will be facilitated by studies related to LPL receptors and their downstream signaling pathways. Unidentified receptors for these LPLs may exist. Using pathophysiological relevant cellular/animal systems and concentrations of LPLs are of paramount importance. Specific antagonists for each LPL receptor under development will be powerful tools not only for basic research, but also for potential therapeutic usages. Development of highly reliable and high-throughput analytic method(s) for LPLs is critically important for basic and translational research. Identification of enzymes controlling abnormal LPL levels in diseases will be an initial step towards the development of novel therapeutics for the treatment.

ACKNOWLEDGEMENT

This work was supported in part by an American Cancer Society Grant RPG-99-062-01-CNE, U.S. Army Medical Research Grant DAMD 17-99-1-9563, NIH RO1CA89229-01A2 and a sub-contract grant from the Pacific Ovarian Cancer Research Consortium P50 CA83636 (PI: Nicole Urban) to Y.X.

ABBREVIATIONS

Akt	=	Protein Kinase B
BSA	=	bovine serum albumin
CFTR	=	Cystic Fibrosis Transmembrane Regulator
EGF	=	Epidermal Growth Factor
ERK	=	Extracellular signal-Regulated Kinase
GPCR	=	G Protein-Coupled Receptor
LPA	=	Lysophosphatidic Acid
LPC	=	Lysophosphatidylcholine
LPI	=	Lysophosphatidylinositol
LPS	=	Lysophosphatidylserine
MAPK	=	Mitogen-Activated Protein Kinase
MEK	=	MAPK Kinase
PI3K	=	Phosphatidylinositol 3-Kinase
PLD	=	Phospholipase D
S1P	=	Sphingosine-1-Phosphate
SELDI	=	Surface-enhanced laser desorption and ionization
SPC	=	Sphingosylphosphorylcholine

Table 1. Concentrations of LPLs in human body fluids

	Plasma (n=68)		Ascites (n=44)	
	Ovarian cancer (n=39)	Healthy control (n=29)	Ovarian cancer (n=29)	Chronic hepatitis (n=15)
Ether-linked LPAs	0.32 μ M (0.01-5.29)	0.05 μ M (0.02-1.13)	2.93 μ M (0.10-7.38)	0.23 μ M (0.04-1.11)
Acyl-LPAs	3.01 μ M (0.69-12.38)	0.41 μ M (0.06-0.83)	23.34 μ M (0.50-58.55)	2.39 μ M (0.40-6.70)
LPIs	1.61 μ M (0.00-17.74)	0.61 μ M (0.06-1.37)	17.17 μ M (0.46-68.60)	0.71 μ M (0.00-2.61)
LPCs	44.85 μ M (1.68-127.62)	42.45 μ M (12.26-166.49)	35.03 μ M (3.37-69.13)	28.81 μ M (4.66-52.20)
S1P	107.8 nM (0.0-1932.0)	58.3 nM (0.0-129.0)	51.4 nM (0.0-5898.6)	11.1 nM (0.0-100.9)
SPC	8.4 nM (0.0-457.7)	4.6 nM (0.0-73.0)	38.9 nM (3.8-191.1)	15.0 nM (10.3-44.8)

The concentrations are presented as median (range) in μ M or nM as indicated in each cell

Ether-linked LPAs include 16:0-,18:0-alkyl-LPAs and 16:0-, 18:0-alkenyl-LPAs

Acyl-LPAs include 16:0-, 18:0-, 18:1, 18:2, 20:4-, and 22:-6-LPAs

LPIs include 16:0-, 18:0-, and 20:4-LPIs

LPCs include 16:0-, 18:0-, 18:1-, 20:0-, 20:4-, and 22:6-LPCs

Table 2. The effect of LPLs on [³H]thymidine incorporation in cell lines

	LPA (%)	S1P (%)	LPI (%)	SPC (%)	LPC (%)			
					14:0	16:0	18:0	18:1
Ovarian	120-600	100-250	12-80	5-110	NE	50-150	40-160	10-180
Breast	80-200	30-150	5-200	5-150	NE	20-120	40-150	40-300
Prostate	100-250	100-250	40-150	50-200	NE	10-150	80-160	30-240
Non-Malignant	NE	100-150	10-80	10-300	NE	20-80	40-160	80-140
3T3	100-850	100-250	ND	150-250	NE	3-100	3-80	78-150

The effects of LPLs are presented as % of [³H]thymidine incorporation of control cells (when cells were treated with the solvent only).

Ovarian cancer cell lines: HEY, OCC1, ovca420, ovca429, ovca432, and SKOV3

Breast cancer cells: MCF7, MDA-MB-231, MDA-MB-435, MDA-MB-453, and T47D

Prostate cancer cell lines: PC-3, PC2-4, DU145, and LnCAP

Non-malignant cell lines: MCF10A and HMEC-1

NE: no effect

ND: not determined

LPCs and LPA (18:1-LPA) were from Avanti Polar Lipids (Birmingham, AL); LPI as obtained from Sigma (St. Louis, MO). The [³H]thymidine incorporation was performed as described previously[86, 100]. Briefly, cells were 50-70% confluent before starvation from serum for 24h. Cells were treated with lipids (0.1, 0.3, 1, 3, and 10 μ M) for 24h, and 0.15 μ Ci of [³H]thymidine was added to each well for the last 16 h.

REFERENCES

- [1] Tokumura, A., Fukuzawa, K. and Tsukatani, H. (1978) *Lipids* **13**, 572-574.
- [2] Tokumura, A., Fukuzawa, K., Isobe, J. and Tsukatani, H. (1981) *Biochem Biophys Res Commun* **99**, 391-398.
- [3] van Corven, E. J., Groenink, A., Jalink, K., Eichholtz, T. and Moolenaar, W. H. (1989) *Cell* **59**, 45-54.
- [4] Jalink, K., van Corven, E. J. and Moolenaar, W. H. (1990) *J Biol Chem* **265**, 12232-12239.
- [5] van Corven, E. J., van Rijswijk, A., Jalink, K., van der Bend, R. L., van Blitterswijk, W. J. and Moolenaar, W. H. (1992) *Biochem J* **281**, 163-169.
- [6] van der Bend, R. L., de Widt, J., van Corven, E. J., Moolenaar, W. H. and van Blitterswijk, W. J. (1992) *Biochem J* **285**, 235-240.
- [7] Zhang, H., Desai, N. N., Olivera, A., Seki, T., Brooker, G. and Spiegel, S. (1991) *J Cell Biol* **114**, 155-167.
- [8] Desai, N. N., Zhang, H., Olivera, A., Mattie, M. E. and Spiegel, S. (1992) *J Biol Chem* **267**, 23122-23128.
- [9] Tigyi, G. (2001) *Prostaglandins* **64**, 47-62.
- [10] Moolenaar, W. H. (2000) *Ann N Y Acad Sci* **905**, 1-10.
- [11] Contos, J. J., Ishii, I. and Chun, J. (2000) *Mol Pharmacol* **58**, 1188-1196.
- [12] Goetzl, E. J. (2001) *Prostaglandins* **64**, 11-20.
- [13] Lynch, K. R. and Macdonald, T. L. (2001) *Prostaglandins Other Lipid Mediat* **64**, 33-45.
- [14] Lynch, K. R. and Im, I. (1999) *Trends Pharmacol Sci* **20**, 473-475.

- [15] Fukushima, N. and Chun, J. (2001) *Prostaglandins* **64**, 21-32.
- [16] Fukushima, N., Ishii, I., Contos, J. J., Weiner, J. A. and Chun, J. (2001) *Annu Rev Pharmacol Toxicol* **41**, 507-534.
- [17] Kranenburg, O. and Moolenaar, W. H. (2001) *Oncogene* **20**, 1540-1546.
- [18] Moolenaar, W. H. (1999) *Exp Cell Res* **253**, 230-238.
- [19] Pyne, S. and Pyne, N. J. (2000) *Biochem J* **349**, 385-402.
- [20] Spiegel, S. and Milstien, S. (2000) *Biochim Biophys Acta* **1484**, 107-116.
- [21] Pages, C., Simon, M., Valet, P. and Saulnier-Blache, J. S. (2001) *Prostaglandins* **64**, 1-10.
- [22] Yatomi, Y., Ozaki, Y., Ohmori, T. and Igarashi, Y. (2001) *Prostaglandins* **64**, 107-122.
- [23] Olivera, A. and Spiegel, S. (2001) *Prostaglandins* **64**, 123-134.
- [24] Mandala, S. M. (2001) *Prostaglandins* **64**, 143-156.
- [25] Erickson, J. R., Hasegawa, Y., Fang, X., Eder, A., Mao, M., Furui, T., Aoki, J., Morris, A. and Mills, G. B. (2001) *Prostaglandins* **64**, 63-81.
- [26] Mills, G. B., Eder, A., Fang, X., Hasegawa, Y., Mao, M., Lu, Y., Tanyi, J., Tabassam, F. H., Wiener, J., Lapushin, R., Yu, S., Parrott, J. A., Compton, T., Tribbley, W., Fishman, D., Stack, M. S., Gaudette, D., Jaffe, R., Furui, T., Aoki, J. and Erickson, J. R. (2002) *Cancer Treat Res* **107**, 259-83.
- [27] Spiegel, S., English, D. and Milstien, S. (2002) *Trends Cell Biol* **12**, 236-42.
- [28] Swarthout, J. T. and Walling, H. W. (2000) *Cell Mol Life Sci* **57**, 1978-85.
- [29] Saulnier-Blache, J. S., Girard, A., Simon, M. F., Lafontan, M. and Valet, P. (2000) *J Lipid Res* **41**, 1947-1951.
- [30] Sciorra, V. A. and Morris, A. J. (2002) *Biochim Biophys Acta* **1582**, 45-51.

- [31] Yatomi, Y., Ruan, F., Ohta, J., Welch, R. J., Hakomori, S. and Igarashi, Y. (1995) *Anal Biochem* **230**, 315-320.
- [32] Edsall, L. C. and Spiegel, S. (1999) *Anal Biochem* **272**, 80-86.
- [33] Edsall, L., Vann, L., Milstien, S. and Spiegel, S. (2000) *Methods Enzymol* **312**, 9-16
- [34] Kralik, S. F., Du, X., Patel, C. and Walsh, J. P. (2001) *Anal Biochem* **294**, 190-193.
- [35] Okajima, F. (2001) *Nippon Yakurigaku Zasshi* **118**, 383-388.
- [36] Min, J. K., Yoo, H. S., Lee, E. Y., Lee, W. J. and Lee, Y. M. (2002) *Anal Biochem* **303**, 167-175.
- [37] Chen, J. H., Zou, F., Wang, N. D., Xie, S. W. and Zhang, X. (2000) *Bioorg Med Chem Lett* **10**, 1691-1693.
- [38] Wu, R., Huang, Y. H., Elinder, L. S. and Frostegard, J. (1998) *Arterioscler Thromb Vasc Biol* **18**, 626-630.
- [39] Wu, R., Svenungsson, E., Gunnarsson, I., Andersson, B., Lundberg, I., Schafer Elinder, L. and Frostegard, J. (1999) *Lupus* **8**, 142-150.
- [40] Wu, R., Svenungsson, E., Gunnarsson, I., Haegerstrand-Gillis, C., Andersson, B., Lundberg, I., Elinder, L. S. and Frostegard, J. (1999) *Clin Exp Immunol* **115**, 561-566.
- [41] Wu, R., Lemne, C., de Faire, U. and Frostegard, J. (2001) *Hypertension* **37**, 154-159.
- [42] Ponzin, D., Mancini, C., Toffano, G., Bruni, A. and Doria, G. (1989) *Immunopharmacology* **18**, 167-176.
- [43] Mano, N., Oda, Y., Yamada, K., Asakawa, N. and Katayama, K. (1997) *Anal Biochem* **244**, 291-300
- [44] Sullards, M. C. (2000) *Methods Enzymol* **312**, 32-45.

- [45] Dessort, D., Mersel, M., Lepage, P. and Van Dorsselaer, A. (1984) *Anal Biochem* **142**, 43-52.
- [46] Arnoux, B., Durand, J., Rigaud, M., Vargaftig, B. B. and Benveniste, J. (1981) *Agents & Actions* **11**, 555-556.
- [47] Haraldsen, P. E., Clay, K. L. and Murphy, R. C. (1987) *J Lipid Res* **28**, 42-49.
- [48] Schiller, J., Zschornig, O., Petkovic, M., Muller, M., Arnhold, J. and Arnold, K. (2001) *J Lipid Res* **42**, 1501-1508.
- [49] Schiller, J., Hammerschmidt, S., Wirtz, H., Arnhold, J. and Arnold, K. (2001) *Chem Phys Lipids* **112**, 67-79.
- [50] Petkovic, M., Schiller, J., Muller, J., Muller, M., Arnold, K. and Arnhold, J. (2001) *Analyst* **126**, 1042-1050.
- [51] Taguchi, R., Hayakawa, J., Takeuchi, Y. and Ishida, M. (2000) *J Mass Spectrom* **35**, 953-966.
- [52] Baker, D. L., Desiderio, D. M., Miller, D. D., Tolley, B. and Tigyi, G. J. (2001) *Anal Biochem* **292**, 287-295.
- [53] Xiao, Y., Chen, Y., Kennedy, A. W., Belinson, J. and Xu, Y. (2000) *Ann N Y Acad Sci* **905**, 242-259.
- [54] Xiao, Y. J., Schwartz, B., Washington, M., Kennedy, A., Webster, K., Belinson, J. and Xu, Y. (2001) *Anal Biochem* **290**, 302-313.
- [55] Xu, Y., Shen, Z., Wiper, D., Wu, M., Morton, R., Elson, P., Kennedy, A., Belinson, J., Markman, M. and Casey, G. (1998) *JAMA* **280**, 719-723.
- [56] Sasagawa, T., Suzuki, K., Shiota, T., Kondo, T. and Okita, M. (1998) *J Nutr Sci & Vitaminol* **44**, 809-818.

- [57] Sasagawa, T., Okita, M., Murakami, J., Kato, T. and Watanabe, A. (1999) *Lipids* **34**, 17-21
- [58] Okita, M., Gaudette, D. C., Mills, G. B. and Holub, B. J. (1997) *Int J Cancer* **71**, 31-34.
- [59] Sekas, G., Patton, G. M., Lincoln, E. C. and Robins, S. J. (1985) *J Lab Clin Med* **105**, 190-194.
- [60] Eichholtz, T., Jalink, K., Fahrenfort, I. and Moolenaar, W. H. (1993) *Biochem J* **291**, 677-680.
- [61] Watson, S. P., McConnell, R. T. and Lapetina, E. G. (1985) *Biochem J* **232**, 61-66.
- [62] Tokumura, A., Iimori, M., Nishioka, Y., Kitahara, M., Sakashita, M. and Tanaka, S. (1994) *Am J Physiol* **267**, C204-210.
- [63] Yatomi, Y., Ruan, F., Hakomori, S. and Igarashi, Y. (1995) *Blood* **86**, 193-202.
- [64] Sano, T., Baker, D., Virag, T., Wada, A., Yatomi, Y., Kobayashi, T., Igarashi, Y. and Tigyi, G. (2002) *J Biol Chem* **277**, 21197-21206.
- [65] Baker, D. L., Umstot, E. S., Desiderio, D. M. and Tigyi, G. J. (2000) *Ann N Y Acad Sci* **905**, 267-269.
- [66] Bigon, E., Bruni, A., Mietto, L. and Toffano, G. (1980) *Br J Pharmacol* **69**, 11-12.
- [67] Hara, N., Murakami, M., Inoue, K. and Kudo, I. (1996) *Biol Pharm Bull* **19**, 474-476.
- [68] Aoki, J., Nagai, Y., Hosono, H., Inoue, K. and Arai, H. (2002) *Biochim Biophys Acta* **1582**, 26-32.
- [69] Baker, D. L., Morrison, P., Miller, B., Riely, C. A., Tolley, B., Westermann, A. M., Bonfrer, J. M., Bais, E., Moolenaar, W. H. and Tigyi, G. (2002) *JAMA* **287**, 3081-3082.
- [70] Chun, J., Contos, J. J. and Munroe, D. (1999) *Cell Biochem Biophys* **30**, 213-42
- [71] Xu, Y. (2002) *Biochim Biophys Acta* **1582**, 81-88.

- [72] Boujaoude, L. C., Bradshaw-Wilder, C., Mao, C., Cohn, J., Ogretmen, B., Hannun, Y. A. and Obeid, L. M. (2001) *J Biol Chem* **276**, 35258-35264.
- [73] Snitko, Y., Yoon, E. T. and Cho, W. (1997) *Biochem J* **321**, 737-741.
- [74] Ancellin, N., Colmont, C., Su, J., Li, Q., Mittereder, N., Chae, S. S., Stefansson, S., Liao, G. and Hla, T. (2002) *J Biol Chem* **277**, 6667-6675.
- [75] Umezu-Goto, M., Kishi, Y., Taira, A., Hama, K., Dohmae, N., Takio, K., Yamori, T., Mills, G. B., Inoue, K., Aoki, J. and Arai, H. (2002) *J Cell Biol* **158**, 227-233.
- [76] Tokumura, A., Majima, E., Kariya, Y., Tominaga, K., Kogure, K., Yasuda, K. and Fukuzawa, K. (2002) *J Biol Chem. Online*
- [77] Moolenaar, W. H. (2002) *J Cell Biol* **158**, 197-199.
- [78] Tokumura, A., Harada, K., Fukuzawa, K. and Tsukatani, H. (1986) *Biochim Biophys Acta* **875**, 31-38.
- [79] Tokumura, A., Fujimoto, H., Yoshimoto, O., Nishioka, Y., Miyake, M. and Fukuzawa, K. (1999) *Life Sciences* **65**, 245-253.
- [80] Tokumura, A., Miyake, M., Nishioka, Y., Yamano, S., Aono, T. and Fukuzawa, K. (1999) *Biol Reprod* **61**, 195-199.
- [81] Tokumura, A., Kanaya, Y., Kitahara, M., Miyake, M., Yoshioka, Y. and Fukuzawa, K. (2002) *J Lipid Res* **43**, 307-135.
- [82] Fang, X., Schummer, M., Mao, M., Yu, S., Tabassam, F. H., Swaby, R., Hasegawa, Y., Tanyi, J. L., LaPushin, R., Eder, A., Jaffe, R., Erickson, J. and Mills, G. B. (2002) *Biochim Biophys Acta* **1582**, 257-264.
- [83] Soule, H. D., Maloney, T. M., Wolman, S. R., Peterson, W. D., Jr., Brenz, R., McGrath, C. M., Russo, J., Pauley, R. J., Jones, R. F. and Brooks, S. C. (1990) *Cancer Res* **50**, 6075-6086.

- [84] Ades, E. W., Candal, F. J., Swerlick, R. A., George, V. G., Summers, S., Bosse, D. C. and Lawley, T. J. (1992) *J Invest Dermatol* **99**, 683-690.
- [85] Schwartz, B. M., Hong, G., Morrison, B. H., Wu, W., Baudhuin, L. M., Xiao, Y. J., Mok, S. C. and Xu, Y. (2001) *Gynecol Oncol* **81**, 291-300.
- [86] Frankel, A. and Mills, G. B. (1996) *Clin Cancer Res* **2**, 1307-1313.
- [87] Baudhuin, L. M., Cristina, K. L., Lu, J. and Xu, Y. (2002) *Mol Pharmacol* **62**, 660-671.
- [88] Pustilnik, T. B., Estrella, V., Wiener, J. R., Mao, M., Eder, A., Watt, M. A., Bast, R. C., Jr. and Mills, G. B. (1999) *Clin Cancer Res* **5**, 3704-3710.
- [89] Fishman, D. A., Liu, Y., Ellerbroek, S. M. and Stack, M. S. (2001) *Cancer Res* **61**, 3194-3199.
- [90] Lu, J., Xiao Yj, Y. J., Baudhuin, L. M., Hong, G. and Xu, Y. (2002) *J Lipid Res* **43**, 463-476.
- [91] Hong, G., Baudhuin, L. M. and Xu, Y. (1999) *FEBS Lett* **460**, 513-518.
- [92] Hu, Y. L., Tee, M. K., Goetzl, E. J., Auersperg, N., Mills, G. B., Ferrara, N. and Jaffe, R. B. (2001) *J Natl Cancer Inst* **93**, 762-768.
- [93] Xu, Y., Casey, G. and Mills, G. (1995) *J Cell Physiol* **163**, 441-450.
- [94] Xu, Y., Fang, X., Casey, G. and Mills, G. (1995) *Biochem J* **309**, 933-940.
- [95] Panetti, T. S., Nowlen, J. and Mosher, D. F. (2000) *Arterioscler Thromb Vasc Biol* **20**, 1013-1019.
- [96] Spiegel, S. and Milstien, S. (2002) *J Biol Chem.*, Online
- [97] Spiegel, S., Olivera, A., Zhang, H., Thompson, E. W., Su, Y. and Berger, A. (1994) *Breast Cancer Res Treat* **31**, 337-348.
- [98] Corda, D., Iurisci, C. and Berrie, C. P. (2002) *Biochim Biophys Acta* **1582**, 52-69.
- [99] Metz, S. A. (1986) *Biochem Biophys Res Commun* **138**, 720-727.

- [100] Falasca, M., Silletta, M. G., Carvelli, A., Di Francesco, A. L., Fusco, A., Ramakrishna, V. and Corda, D. (1995) *Oncogene* **10**, 2113-2124.
- [101] Chisolm, G. M., 3rd and Chai, Y. (2000) *Free Radic Biol Med* **28**, 1697-1707.
- [102] Dart, A. M. and Chin-Dusting, J. P. (1999) *Cardiovasc Res* **43**, 308-322.
- [103] Kita, T., Kume, N., Ishii, K., Horiuchi, H., Arai, H. and Yokode, M. (1999) *Diabetes Res Clin Pract* **45**, 123-126.
- [104] Murphy, A. A., Santanam, N., Morales, A. J. and Parthasarathy, S. (1998) *J Clin Endocrinol Metab* **83**, 2110-2113.
- [105] Marathe, G. K., Silva, A. R., de Castro Faria Neto, H. C., Tjoelker, L. W., Prescott, S. M., Zimmerman, G. A. and McIntyre, T. M. (2001) *J Lipid Res* **42**, 1430-1437.
- [106] Kabarowski, J. H., Zhu, K., Le, L. Q., Witte, O. N. and Xu, Y. (2001) *Science* **293**, 702-705.
- [107] Zhu, K., Baudhuin, L. M., Hong, G., Williams, F. S., Cristina, K. L., Kabarowski, J. H., Witte, O. N. and Xu, Y. (2001) *J Biol Chem* **276**, 41325-41335.
- [108] Mochizuki, M., Zigler, J. S., Jr., Russell, P. and Gery, I. (1982) *Curr Eye Res* **2**, 621-624.
- [109] Meyer zu Heringdorf, D., Himmel, H. M. and Jakobs, K. H. (2002) *Biochim Biophys Acta* **1582**, 178-189.
- [110] Spiegel, S. and Milstien, S. (1995) *Journal of Membrane Biology* **146**, 225-237.
- [111] Desai, N. N. and Spiegel, S. (1991) *Biochem Biophys Res Commun* **181**, 361-366.
- [112] Desai, N. N., Carlson, R. O., Mattie, M. E., Olivera, A., Buckley, N. E., Seki, T., Brooker, G. and Spiegel, S. (1993) *J Cell Biol* **121**, 1385-1395.
- [113] Yamada, T., Okajima, F., Ohwada, S. and Kondo, Y. (1997) *Cell Mol Life Sci* **53**, 435-441.
- [114] Wakita, H., Matsushita, K., Nishimura, K., Tokura, Y., Furukawa, F. and Takigawa, M. (1998) *J Investigat Dermatol* **110**, 253-258.

- [115] Bitar, K. N. and Yamada, H. (1995) *Am J Physiol* **269**, G370-377.
- [116] Sun, L., Xu, L., Henry, F. A., Spiegel, S. and Nielsen, T. B. (1996) *J Invest Dermatol* **106**, 232-237.
- [117] Sugiyama, E., Uemura, K., Hara, A. and Taketomi, T. (1993) *J Biochem (Tokyo)* **113**, 467-472.
- [118] Pushkareva, M. and Hannun, Y. A. (1994) *Biochim Biophys Acta* **1221**, 54-60.
- [119] Seufferlein, T. and Rozengurt, E. (1995) *J Biol Chem* **270**, 24334-24342.
- [120] Seufferlein, T. and Rozengurt, E. (1995) *J Biol Chem* **270**, 24343-24351.
- [121] Bunemann, M., Liliom, K., Brandts, B. K., Pott, L., Tseng, J. L., Desiderio, D. M., Sun, G., Miller, D. and Tigyi, G. (1996) *EMBO J* **15**, 5527-5534.
- [122] Furuya, S., Kurono, S. and Hirabayashi, Y. (1996) *J Lipid Mediat Cell Signal* **14**, 303-311
- [123] Orlati, S., Porcelli, A. M., Hrelia, S. and Rugolo, M. (1998) *Cell Calcium* **23**, 387-394.
- [124] Chen, P. F., Chin, T. Y. and Chueh, S. H. (1998) *Kidney Int* **54**, 1470-1483.
- [125] Berger, A., Rosenthal, D. and Spiegel, S. (1995) *Proc Nat Acad Sci USA* **92**, 5885-5889.
- [126] Imokawa, G., Takagi, Y., Higuchi, K., Kondo, H. and Yada, Y. (1999) *J Invest Dermatol* **112**, 91-96.
- [127] Spangelo, B. L. and Jarvis, W. D. (1996) *Endocrinology* **137**, 4419-4426.
- [128] Tokura, Y., Wakita, H., Seo, N., Furukawa, F., Nishimura, K. and Takigawa, M. (1999) *J Invest Dermatol. Symposium Proceedings* **4**, 184-189.
- [129] Sekiguchi, K., Yokoyama, T., Kurabayashi, M., Okajima, F. and Nagai, R. (1999) *Cir Res* **85**, 1000-1008.
- [130] Xu, Y., Zhu, K., Hong, G., Wu, W., Baudhuin, L. M., Xiao, Y. and Damron, D. S. (2000) *Nat Cell Biol* **2**, 261-267.

- [131] Rodriguez-Lafrasse, C. and Vanier, M. T. (1999) *Neurochem Res* **24**, 199-205.
- [132] Strasberg, P. M. and Callahan, J. W. (1988) *Biochem Cell Biol* **66**, 1322-1332.
- [133] Murata, Y., Ogata, J., Higaki, Y., Kawashima, M., Yada, Y., Higuchi, K., Tsuchiya, T., Kawainami, S. and Imokawa, G. (1996) *J Invest Dermatol* **106**, 1242-1249.

SPC/LPC Receptors

Linnea M. Baudhuin^{1,2}, Yijin Xiao¹, and Yan Xu^{1,2,3}

¹Department of Cancer Biology, Cleveland Clinic Foundation, 9500 Euclid Avenue, Cleveland, OH, 44195, ²Department of Chemistry, Cleveland State University, Euclid and East 24th Street, Cleveland, OH, 44115, ³Department of Gynecology and Obstetrics, Cleveland Clinic Foundation, 9500 Euclid Avenue, Cleveland, OH, 44195

Correspondence to: Dr. Yan Xu, Department of Cancer Biology, NB-40, Cleveland Clinic Foundation, Cleveland, OH 44195, Telephone: 216-444-1168, Fax: 216-445-6269, E-mail: xuy@ccf.org

I. Introduction

Lysophospholipids (LPLs) as signaling molecules, and in particular, extracellular signaling molecules, have been recognized and studied in the past decade. Among LPLs, the biological effects and signaling mechanisms of lysophosphatidic acid (LPA), sphingosine-1-phosphate (S1P), and their receptors (LPA_{1,3} and S1P_{1,5}) have been studied most extensively (1-4). The signaling mechanisms of their corresponding choline derivatives, lysophosphatidylcholine (LPC) and sphingosylphosphorylcholine (SPC), on the other hand, have been examined to a much lower extent, although their extracellular existence and evidence of their signaling properties have long been recognized.

Addition of a positively charged choline group to the negatively charged phosphate group provides LPC and SPC with zwitterionic and detergent-like properties. In fact, LPC is cell lytic at concentrations >30 μM when bovine serum albumin (BSA) is absent (5). Moreover, the specific receptors for LPC and SPC were not previously identified. Thus, controversy has arisen as to whether LPC, and possibly SPC, act as specific signaling molecules or molecules modulating cellular functions nonspecifically, and whether their actions are receptor-mediated. This situation has been changed recently with the identification of three G protein-coupled receptors (GPCRs): OGR1, GPR4, and G2A, as receptors for LPC and SPC (6-8). These discoveries provide an intriguing and novel opportunity to studying the pathophysiological and functional roles of SPC, LPC, and their receptors.

II. Physiological and pathological functions of LPC and SPC

The potential physiological and pathological functions of LPC and SPC have been recently reviewed (9, 10). While LPA, S1P, LPC, and SPC may share similar, overlapping, or opposing effects in some cellular systems, each of these lipids may also have its own unique functions. For example, all four of these LPLs have been shown to play some role in wound healing and some inflammatory processes (11-15). LPA and its receptors are involved in nervous system development and S1P has been implicated in cardiovascular development (12, 16, 17). On the other hand, LPC and SPC are implicated more

specifically in diseases involving immunological and inflammatory processes, such as atherosclerosis and systemic lupus erythematosus (18-21).

The metabolic pathways involved in synthesis and release of LPC and SPC are closely related to those of LPA, and potentially SIP. A lysophospholipase-D (lysoPLD) activity, which directly converts LPC to LPA, has been reported previously (22, 23). We have recently observed that when sterile, cell-free ovarian cancer ascites samples, but not non-malignant ascites, were incubated at 37°C, LPA levels were increased over time (Fig. 1A). The LPA production was completely abolished when EDTA or EGTA was added to the ascites, indicating that the LPA production in ovarian cancer ascites was likely due to a soluble enzymatic activity that requires bivalent metal ions and calcium. Interestingly, during the same time course, LPC levels were decreased (Fig. 1B), suggesting a lysoPLD-like activity may be responsible for LPA production in ovarian cancer ascites. Furthermore, SPC is a substrate for bacterial PLD (unpublished observations), and thus, SPC may be converted to SIP in mammalian cells *in vivo*, although such an endogenous activity has not been identified. These data support the notion that the physiological roles of LPLs may be closely related and intertwined, and thus, may play a more complex role *in vivo* than what is observed *in vivo* when a single LPL is tested.

III. Identification of receptors for SPC and LPC

The identification of receptors for SPC and LPC first began with the cloning of OGR1 from the HEY ovarian cancer cell line, using a PCR-based cloning strategy with primers based on the sequences of receptors for platelet-activating factor (PAF) and thrombin (24). OGR1 shares approximately 30% sequence homology with the PAF receptor, which indicated that the ligand for OGR1 may be also a lipid molecule, and may also contain a choline group. Functional analyses were performed, which provided evidence for OGR1 as the first high affinity receptor identified for SPC (6). Similar studies were performed to determine that SPC and/or LPC were ligands for GPR4 and G2A (7, 8). OGR1, GPR4, and G2A have no or very low affinity to LPA, SIP, PAF, lyso-PAF, lysophosphatidylinositol (LPI), PAF, sphingomyelin, ceramide, psychosine, glucosyl- β 1,1'-sphingosine (Glu-Sph), galactosyl- β 1,1'-ceramide

(Gal-Cer), and lactosyl- β 1,1'-ceramide (Lac-Cer) (6-8). TDAG8, a fourth related receptor that is 36% homologous to OGR1, has been recently identified as a receptor for a glycosphingolipid, psychosine (galactosyl- β 1,1'-sphingosine) (25). Due to the relative high homologies of these receptors, the potentials exist for TDAG8 to also be a LPC/SPC receptor and/or for OGR1, GPR4, and G2A to be receptors for psychosine.

Although LPA/S1P and SPC/LPC subfamily receptors are GPCRs for structurally-related lysolipids, the two receptor subfamilies share little sequence homology and may prefer different G protein coupling in certain signaling pathways. Evidence supports that three major G protein families (G_i , G_q and $G_{12/13}$) are coupled to these receptors. Compared to the majority of GPCRs, which employ G_q as a mediator for calcium mobilization, SPC- and LPC-induced calcium release from intercellular stores are mediated through G_i in MCF10A cells, although other cell lines remained to be tested. Furthermore, while ERK activation via GPCRs is mainly mediated through G_i , SPC-induced PI3K and ERK activation via OGR1 appear to be mediated by a PTX-insensitive G protein (6 and unpublished observations). Nonetheless, these differences are not restricted to LPC/SPC receptors. G_i -mediated calcium release and G_q -mediated PI3K and ERK activation have been reported previously (26-29).

We note that the k_d values for LPC/SPC ligand binding are about one to two orders of magnitude higher than those for LPA/S1P receptors. Likewise, the serum and plasma concentrations of LPC are usually one to two orders of magnitude higher than those of LPA. Thus, the k_d values of their receptors may reflect a physiological adaptation to their concentrations. At the normal physiological concentrations of LPC (5-180 μ M), if all of the LPC were in an active form, then its receptors would be saturated, down-regulated, and/or desensitized. However, *in vivo*, the functionally available concentration of LPC may be affected by such conditions as percentage of LPC bound to albumin or lipoprotein, and compartmentalization (i.e. tissue, cellular, and subcellular distribution) of LPC (30-32). The concentrations of both S1P and SPC in physiological fluids are in the nM to sub- μ M range. The lower affinity of SPC for its receptors may suggest: 1) a physiological adaptation for a lower response to SPC; 2) the presence of a different, higher affinity receptor(s) for SPC, which cannot be ruled out; and 3) these

receptors (LPC/SPC subfamily receptors) may have different endogenous ligand(s). These issues remain to be further investigated.

V. Perspectives

Until now, very limited information has been accumulated regarding the pathophysiological functions of SPC, LPC, and their receptors. G2A-null mice develop a late-onset autoimmune disease (33). Some of the effects of G2A may be compensated by other LPC receptors. Generation of OGR1- and GPR4-null mice is in progress and will provide important information about the physiological functions of these receptors. Comparative studies between LPA/S1P and LPC/SPC may generate interesting data to advance our understanding of these lipids, since: 1) LPA and S1P are prototypes of bioactive extracellular lipid signaling molecules; 2) LPC and SPC share similar, yet distinct signaling pathways as those induced by LPA and S1P; 3) the metabolic pathways are linked between LPA/S1P and LPC/SPC; and 4) all of these LPLs are present in serum and plasma. LPA, SPC, and LPC levels are elevated under pathological conditions. It can be foreseen that the identification of their receptors will facilitate our understanding of the roles these LPLs play in physiological and pathological processes.

Acknowledgement

This work was supported in part by the US Army Medical Research Grant DAMD 17-99-1-9563, NIH RO1CA89228-01A2, NIHRO1HL68804-01, and a Wilson Medical Research Foundation grant to Yan Xu

References

1. Hla, T., Lee, M. J., Ancellin, N., Paik, J. H., and Kluk, M. J. (2001). Lysophospholipids--receptor revelations. *Science* **294**, 1875-1888.
2. Goetzl, E. J., and An, S. (1998). Diversity of cellular receptors and functions for the lysophospholipid growth factors lysophosphatidic acid and sphingosine 1-phosphate. *FASEB J.* **12**, 1589-98.

3. Spiegel, S. (1999). Sphingosine 1-phosphate: a prototype of a new class of second messengers. *J. Leukoc. Biol.* **65**, 341-344.
4. Moolenaar, W. H. (1999). Bioactive lysophospholipids and their G protein-coupled receptors. *Exp. Cell. Res.* **253**, 230-238.
5. Jalink, K., van Corven, E. J., and Moolenaar, W.H. (1990). Lysophosphatidic acid, but not phosphatidic acid, is a potent Ca²⁺-mobilizing stimulus for fibroblasts. Evidence for an extracellular site of action. *J. Biol. Chem.* **265**, 12232-12239.
6. Xu, Y., Zhu, K., Hong, G., Wu, W., Baudhuin, L. M., Xiao, Y., and Damron, D. S. (2000). Sphingosylphosphorylcholine is a ligand for ovarian cancer G-protein-coupled receptor 1. *Nat. Cell Biol.* **2**, 261-267.
7. Zhu, K., Baudhuin, L. M., Hong, G., Williams, F. S., Cristina, K. L., Kabarowski, J. H., Witte, O. N., and Xu, Y. (2001). Sphingosylphosphorylcholine and lysophosphatidylcholine are ligands for the G protein-coupled receptor GPR4. *J. Biol. Chem.* **276**, 41325-41335.
8. Kabarowski, J. H., Zhu, K., Le, L. Q., Witte, O. N., and Xu, Y. (2001). Lysophosphatidylcholine as a ligand for the immunoregulatory receptor G2A. *Science* **293**, 702-705.
9. Chisolm, G. M. III, and Chai, Y. (2000). Regulation of cell growth by oxidized LDL. *Free Radic. Biol. Med.* **28**, 1697-1707.
10. Prieschl, E. E., and Baumruker, T. (2000). Sphingolipids: second messengers, mediators and raft constituents in signaling. *Immunol. Today* **21**, 555-560.
11. Lee, H., Goetzl, E. J., and An, S. (2000). Lysophosphatidic acid and sphingosine 1-phosphate stimulate endothelial cell wound healing. *Am. J. Physiol. Cell Physiol.* **278**, C612-C618.
12. Lynch, K. R., and Macdonald, T. L. (2001). Structure activity relationships of lysophospholipid mediators. *Prostaglandins Other Lipid Mediat.* **64**, 33-45.
13. Igarashi, Y., and Yatomi, Y. (1998). Sphingosine 1-phosphate is a blood constituent released from activated platelets, possibly playing a variety of physiological and pathophysiological roles. *Acta Biochim Pol.* **45**, 299-309.

14. Sun, L., Xu, L., Henry, F. A., Spiegel, S., and Nielsen, T. B. (1996). A new wound healing agent-sphingosylphosphorylcholine. *J. Invest. Dermatol.* **106**, 232-237.
15. Murugesan, G., and Fox, P. L. (1996). Role of lysophosphatidylcholine in the inhibition of endothelial cell motility by oxidized low density lipoprotein. *J. Clin. Invest.* **97**, 2736-2744.
16. Fukushima, N., Ishii, I., Contos, J. J., Weiner, J. A., and Chun, J. (2001). Lysophospholipid receptors. *Annu. Rev. Pharmacol. Toxicol.* **41**, 507-534.
17. Tigyi, G. (2001). Physiological responses to lysophosphatidic acid and related glycerophospholipids. *Prostaglandins Other Lipid Mediat.* **64**, 47-62.
18. Lusis, A. J. (2000). Atherosclerosis. *Nature* **407**, 233-241.
19. Koh, J. S., Wang, Z., and Levine, J. S., (2000). Cytokine dysregulation induced by apoptotic cells is a shared characteristic of murine lupus. *J. Immunol.* **165**, 4190-4201.
20. Murata, Y., Ogata, J., Higaki, Y., Kawashima, M., Yada, Y., Higuchi, K., Tsuchiya, T., Kawainami, S., and Imokawa, G. (1996). Abnormal expression of sphingomyelin acylase in atopic dermatitis: an etiologic factor for ceramide deficiency? *J. Invest. Dermatol.* **106**, 1242-1249.
21. Sugiyama, E., Uemura, K., Hara, A., and Taketomi, T. (1993). Metabolism and neurite promoting effect of exogenous sphingosylphosphocholine in cultured murine neuroblastoma cells. *J. Biochem (Tokyo)*. **113**, 467-472.
22. Tokumura, A., Miyake, M., Nishioka, Y., Yamano, S., Aono, T., and Fukuzawa, K. (1999). Production of lysophosphatidic acids by lysophospholipase D in human follicular fluids. *Biol. Repro.* **61**, 195-199.
23. Tokumura, A., Yamano, S., Aono, T., and Fukuzawa, K. (2000). Lysophosphatidic acids produced by lysophospholipase D in mammalian serum and body fluid. *Ann. NY Acad. Sci.* **905**, 347-350.
24. Xu, Y., and Casey, G. (1996). Identification of human OGR1, a novel G protein-coupled receptor that maps to chromosome 14. *Genomics* **35**, 397-402.

25. Im, D. S., Heise, C. E., Nguyen, T., O'Dowd, B. F., and Lynch, K. R. (2001). Identification of a molecular target of psychosine and its role in globoid cell formation. *J. Cell Biol.* **16**, 429-434.
26. Ulloa-Aguirre, A., and Conn, P. M. (2000). G protein-coupled receptors and G proteins. *In* "Principles of Molecular Regulation" (P. M. Conn and A. R. Means, Eds.) Humana Press, Totowa, NJ.
27. Bogoyevitch, M. A., Clerk, A., and Sugden, P. H. (1995). Activation of the mitogen-activated protein kinase cascade by pertussis toxin-sensitive and -insensitive pathways in cultured ventricular cardiomyocytes. *Biochem. J.* **309**, 437-443.
28. Hawes, B. E., van Biesen, T., Koch, E. J., Luttrell, L. M., and Lefkowitz, R. H. (1995). Distinct pathways of G_i- and G_q-mediated mitogen-activated protein kinase activation. *J. Biol. Chem.* **270**, 17148-17153.
29. Cobb, M. H., and Goldsmith, E. J. (1995). How MAP kinases are regulated. *J. Biol. Chem.* **270**, 14843-14846
30. Croset, M., Brossard, N., Polette, A., and Lagarde, M. (2000). Characterization of plasma unsaturated lysophosphatidylcholines in human and rat. *Biochem. J.* **345**, 61-67.
31. Carson, M. J., and Lo, D. (2001). Immunology. The push-me pull-you of T cell activation. *Science* **293**, 618-619.
32. Mochizuki, M., Zigler, J. S. Jr, Russell, P., and Gery, I. (1982-1983). Serum proteins neutralize the toxic effect of lysophosphatidyl choline. *Curr. Eye Res.* **2**, 621-624.
33. Le, L. Q., Kabarowski, J. H., Weng, Z., Satterthwaite, A. B., Harvill, E. T., Jensen, E. R., Miller, J. F., and Witte, O. N. (2001). Mice lacking the orphan G protein-coupled receptor G2A develop a late-onset autoimmune syndrome. *Immunity.* **14**, 561-571.
34. Xiao, Y., Chen, Y., Kennedy, A. W., Belinson, J., and Xu, Y. (2000). Evaluation of plasma lysophospholipids for diagnostic significance using electrospray ionization mass spectrometry (ESI-MS) analyses. *Ann. NY Acad. Sci.* **905**, 242-259.

35. Xiao, Y-J., Schwartz, B., Washington, M., Kennedy, A., Webster, K., Belinson, J., and Xu, Y. (2001). Electrospray ionization mass spectrometry analysis of lysophospholipids in human ascitic fluids: comparison of the lysophospholipid contents in malignant vs. nonmalignant ascitic fluids. *Anal. Biochem.* **290**, 312-313.

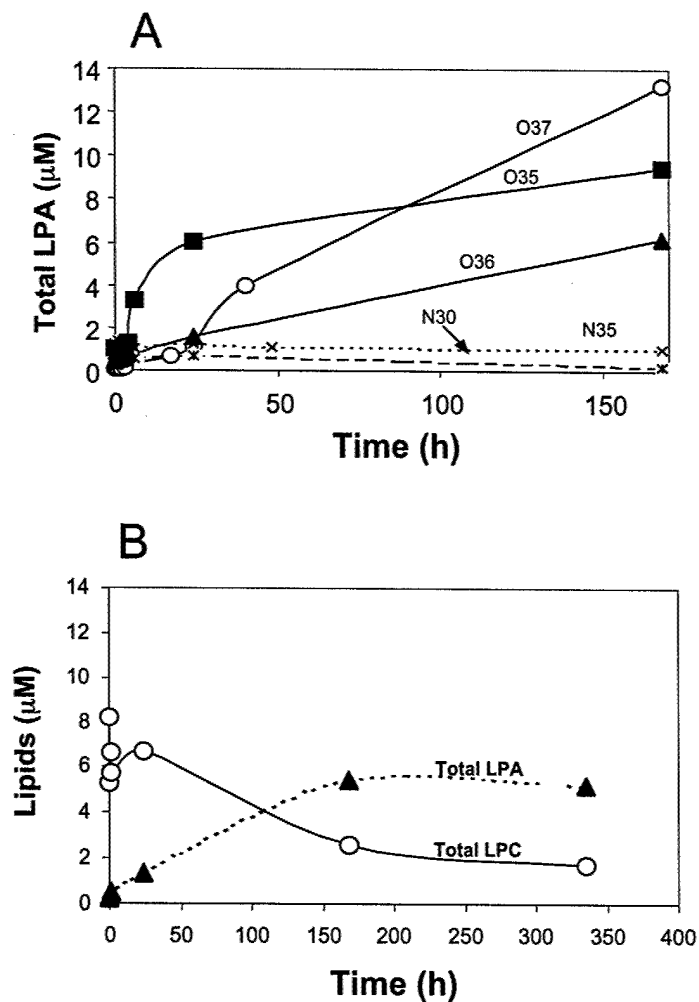

Fig.1. LPA production and LPC degradation in ascites samples. The ascites samples were incubated at 37°C for different durations as indicated, and then quantitatively analyzed for LPA and LPC content by ESI-MS (34, 35). A: LPA production in ascites from patients with ovarian cancer (O35, O36, and O37)

and non-malignant diseases (N30 and N35). B: LPC reduction and LPA production in ascites from a patient with ovarian cancer.

ABSTRACT SUBMISSION FORM

The Cleveland Clinic Foundation

22nd Annual Research Day

October 17, 2002

Abstracts must be received in the Lerner Research Institute
Division Office (Ext. 43900), Mail Code NB21,
Room NB2-52, Lerner Research Bldg.
by 5:00 p.m. on WEDNESDAY, JULY 31, 2002

Hard copy submission accepted only.
(No faxes; no email returns.)
No abstracts accepted after the due date.

All correspondence will be sent to the Submitter, who is responsible for poster presentation, if selected:

ABSTRACT SUBMITTED BY: SAUBHIK SENGUPTA

Check one: M.D.: _____ Ph.D.: D.O.: _____ Ms.: _____ Mr.: _____

DEPARTMENT: CANCER BIOLOGY

MAIL CODE: NB4-40 PHONE: x41182 BEEPER: _____ FAX: x56269

Please check: I verify that all authors have read and approved the final version of this abstract:

Please check: I verify that the staff sponsor named below has read and approved the final version of this abstract:

STAFF SPONSOR: Dr. YAN XU PHONE: x41168

To be eligible for the F. Merlin Bumpus Junior Investigator Award, the First Author must still be employed by CCF at the time of Research Day and must be in one of the following categories. Please check if appropriate:

Predoctoral Student: _____ Postdoc Fellow (Ph.D. or M.D.): Resident (M.D.): _____ Research/Clinical Assoc.: _____

Submitters must still be currently employed by CCF at the time of Research Day. Abstract must be sponsored by a staff member (full, associate, assistant, or project staff). Abstracts co-authored by more than one staff member must still indicate a single staff sponsor. Staff sponsors may submit as many abstracts as they wish, however, only a limited number will be chosen, based on excellence and fair representation of all research at CCF. The work described in the abstract may have been published or presented elsewhere within the past 12 months. INCLUDE TITLE AND ALL AUTHORS. Abstracts must be legible and in camera-ready form. Do not use a font size smaller than 11 point. Abstracts that do not conform to these rules will not be accepted. This form can be photocopied.

Type abstract below this line, to fit on bottom half of this page only.

Production of Lysophosphatidic Acid (LPA) by Laminin – Integrin Interaction is the key for Laminin induced Ovarian Cancer cell Migration

Saubhik Sengupta, Yi-Jin Xiao, and Yan Xu

Department of Cancer Biology, The Lerner Research Institute, The Cleveland
Clinic Foundation, 9500 Euclid Avenue, Cleveland, OH 44143

Ovarian cancer is a highly metastatic disease characterized by ascites formation and dissemination of tumor cells crossing the mesenteric barriers into the peritoneal cavities. We have shown previously that levels of lysophosphatidic acid (LPA) are elevated in plasma of patients with ovarian cancer, even at an early stage, suggesting that LPA plays a role in the early ovarian cancer development and/or cell dissemination. In this study, we demonstrate that laminin, and to a much less extent, collagen I, collagen IV, and vitronectin, stimulated migration of ovarian cancer cells. LPA (0.1 to 30 μ M) further enhanced cell migration through laminin. To our surprise, cell migration stimulated by both laminin and LPA was pertussis toxin (PTX)-sensitive, suggesting the involvement of a Gi/o protein. We have hypothesized that the laminin-induced cell migration is mediated through LPA that activates its receptors (LPA1-3) and a Gi protein. When lipids were analyzed using an electrospray ionization mass spectrometry-based method, we found that laminin, but not vitronectin, collagen I & IV, triggered an outside-in signaling process, which stimulate an i-PLA2 dependent production of LPA. An i-PLA2 specific inhibitor, HELSS, blocked both LPA production and cell migration induced by laminin. Exogenously added LPA restored the migratory ability of HEY cells. Moreover, neutralizing antibody against beta1 integrin blocked both LPA production and cell migration induced by laminin. These results strongly suggest that laminin induced HEY cell migration is mainly mediated by production of LPA. We therefore hypothesize the presence of an autocrine loop in the cells, where LPA is formed because of Laminin integrin interaction and this LPA works back on LPA receptors to stimulate the migratory function of cells. It is currently under investigation which of the particular LPA receptors is involved in cell migration in ovarian cancer cells.

ABSTRACT SUBMISSION FORM

The Cleveland Clinic Foundation

22nd Annual Research Day

October 17, 2002

Abstracts must be received in the Lerner Research Institute
Division Office (Ext. 43900), Mail Code NB21,
Room NB2-52, Lerner Research Bldg.
by 5:00 p.m. on WEDNESDAY, JULY 31, 2002.

Hard copy submission accepted only.
(No faxes; no email returns.)
No abstracts accepted after the due date.

All correspondence will be sent to the Submitter, who is responsible for poster presentation, if selected:

ABSTRACT SUBMITTED BY: Guiying Hong

Check one: M.D.: Ph.D.: D.O.: Ms.: Mr.:

DEPARTMENT: Cancer Biology

MAIL CODE: NB4-40 PHONE: 41182 BEEPER: FAX: 216-445-6269

Please check: I verify that all authors have read and approved the final version of this abstract:

Please check: I verify that the staff sponsor named below has read and approved the final version of this abstract:

STAFF SPONSOR: Yan Xu PHONE: 41168

To be eligible for the F. Merlin Bumpus Junior Investigator Award, the First Author must still be employed by CCF at the time of Research Day and must be in one of the following categories. Please check if appropriate:

Predoctoral Student: Postdoc Fellow (Ph.D. or M.D.): Resident (M.D.): Research/Clinical Assoc.:

Submitters must still be currently employed by CCF at the time of Research Day. Abstract must be sponsored by a staff member (full, associate, assistant, or project staff). Abstracts co-authored by more than one staff member must still indicate a single staff sponsor. Staff sponsors may submit as many abstracts as they wish, however, only a limited number will be chosen, based on excellence and fair representation of all research at CCF. The work described in the abstract may have been published or presented elsewhere within the past 12 months. **INCLUDE TITLE AND ALL AUTHORS.** Abstracts must be legible and in camera-ready form. Do not use a font size smaller than 11 point. Abstracts that do not conform to these rules will not be accepted. This form can be photocopied.

Type abstract below this line, to fit on bottom half of this page only.

OGR1 overexpression modulates cell-cell and cell-matrix interactions and induce cell apoptosis

Guiying Hong and Yan Xu
Department Of Cancer Biology, Lerner Research Institute

We have previously identified OGR1 as a high affinity receptor of SPC (Nature Cell Biology. 2000; 2(5): 261-7). However, the function of OGR1 is still unknown. In order to assess the pathophysiological role of OGR1, we have overexpressed OGR1 in HEK 293 cells. When the OGR1 transfected cells were cultured overnight in serum free medium, they formed multicellular aggregates, and loosely detached from the culture plates. Annexin-V and caspase-3 activity assays demonstrated that these cells went through apoptosis. Control HEK293 cells did not show cell-cell aggregation after starvation. Cell migration decreased 2.5-fold in OGR1 transfected cells as compared to vector transfected cells. Cadherins play a crucial role in epithelial morphogenesis and mediate intercellular adhesion. They are also involved in signal transduction pathways that regulate cell growth and apoptosis, and are frequently down-regulated in invasive metastatic carcinomas. To investigate the mechanism of OGR1 mediated cell morphology change and apoptosis, we compared the E-cadherin expression in OGR1 transfected HEK 293 cells and their control cells. E-cadherin expression level was increased approximately 6-fold in OGR1 transfected cells, when compared with parental HEK293 cells. Expression of E-cadherin was increased in a time and OGR1 expression level dependent manner, which is also correlated to the extent of apoptosis. Co-immunoprecipitation experiments showed an association of E-cadherin and OGR1. Furthermore, integrin β 1 was decreased in OGR1 transfected cells as compared with parental cells. Overall, these observations suggest that the overexpression of OGR1 modulates both the cell-cell and cell-matrix interactions, which might be associated with cell apoptosis.

ABSTRACT SUBMISSION FORM

The Cleveland Clinic Foundation

22nd Annual Research Day

October 17, 2002

Abstracts must be received in the Lerner Research Institute
Division Office (Ext. 43900), Mail Code NB21,
Room NB2-52, Lerner Research Bldg.
by 5:00 p.m. on WEDNESDAY, JULY 31, 2002.

Hard copy submission accepted only.
(No faxes; no email returns.)
No abstracts accepted after the due date.

All correspondence will be sent to the Submitter, who is responsible for poster presentation, if selected:

ABSTRACT SUBMITTED BY: Yi-Jin Xiao

Check one: M.D.: Ph.D.: D.O.: Ms.: Mr.:

DEPARTMENT: Cancer Biology

MAIL CODE: NB40 PHONE: 41182 EEPER: _____ FAX: _____

Please check: I verify that all authors have read and approved the final version of this abstract:

Please check: I verify that the staff sponsor named below has read and approved the final version of this abstract:

STAFF SPONSOR: Yan Xu PHONE: 41168

To be eligible for the F. Merlin Bumpus Junior Investigator Award, the First Author must still be employed by CCF at the time of Research Day and must be in one of the following categories. Please check if appropriate:

Predoctoral Student: Postdoc Fellow (Ph.D. or M.D.): Resident (M.D.): Research/Clinical Assoc.:

Submitters must still be currently employed by CCF at the time of Research Day. Abstract must be sponsored by a staff member (full, associate, assistant, or project staff). Abstracts co-authored by more than one staff member must still indicate a single staff sponsor. Staff sponsors may submit as many abstracts as they wish, however, only a limited number will be chosen, based on excellence and fair representation of all research at CCF. The work described in the abstract may have been published or presented elsewhere within the past 12 months. INCLUDE TITLE AND ALL AUTHORS. Abstracts must be legible and in camera-ready form. Do not use a font size smaller than 11 point. Abstracts that do not conform to these rules will not be accepted. This form can be photocopied.

Type abstract below this line, to fit on bottom half of this page only.

Analyses of LPA in peritoneal washings enhances of the sensitivity and specificity of ovarian cancer early detection

Yi-jin Xiao, Benjamin Schwartz, Donna Fife, April While, Alexander Kennedy, Jerome Belinson, and Yan Xu
Department of Cancer Biology and Department of Gynecology and Obstetrics, Cleveland Clinic Foundation, 9500
Euclid Ave. Cleveland OH, 44195

In previous studies, we have found that lysophosphatidic acid (LPA) are significantly elevated in the plasma from patients with ovarian cancer, compared to that of healthy controls. Using the method developed in our lab, we have detected ovarian cancer with specificity of 100% and sensitivity of 91%. However, when this method was used for patients with benign gynecological diseases, approximately 14% false positive rate was detected. In order to improve the specificity and sensitivity of the test, we have conducted quantitative analyses of lyso-PLs (a total of 34 molecular species) in several different human body fluids: plasma, serum, ascites, peritoneal washings, and urine from patients with ovarian cancer, compared to the patients with benign or borderline tumors. A total of 37 patients were analyzed, with 22 patients had benign gynecological conditions and 15 had ovarian cancer. The most promising data obtained through the current study is that levels of ether-linked LPA (A-LPA) in peritoneal washings were very good in discriminating benign diseases from ovarian cancer. If we set a cutoff at 0.04 μM , all 4 patients with early stage ovarian cancer (three Stage I and one Stage II), one of which was misidentified by LPA level in plasma, had elevated levels of A-LPA. All of the peritoneal washing samples from patients with benign gynecological diseases, including the 4 patients who had relatively high plasma LPA levels, had low levels of A-LPA.

INTERNATIONAL
*Journal
of Cancer*



18th UICC International Cancer Congress
30 June – 5 July 2002
Oslo – Norway
Abstract book

Publication of the International Union Against Cancer
Published for the UICC by Wiley-Liss, Inc.



Articles published online in Wiley InterScience.
www.interscience.wiley.com

Correlation between serum levels of tumor markers and clinical states of ovarian cancer disease

Tumor Markers	Serum Level	Patients at the end of follow up				Correlation
		No. at active disease	%	No. at remission	%	
CA125	Rising or elevated	11	91	0	0	97%
	Decreasing or normal	1	9	18	100	
CEA	Rising or elevated	2	17	3	17	57%
	Decreasing or normal	10	83	15	83	
HCG	Rising or elevated	1	8	0	0	63%
	Decreasing or normal	11	92	18	100	
AFP	Rising or elevated	2	17	2	11	60%
	Decreasing or normal	10	83	16	89	
SA	Rising or elevated	11	92	15	83	47%
	Decreasing or normal	1	8	3	17	

P 805

Experience in ovarian cancer primary systemic chemotherapy of cyclophosphamide, epirubicin and carboplatin with concomitant intraperitoneal carboplatin

P Nurzynski¹, G Wcislo¹, J Korniluk¹, W Z Pawlak¹, K Wcislo¹, A Staszewski², K Brzozowski³, C Szczylik¹

¹Central Clinical Hospital, Military Medical Academy, Department of Oncology, Warsaw, Poland; ²Central Clinical Hospital, Military Medical Academy, Department of Gynecology, Warsaw, Poland; ³Central Clinical Hospital, Military Medical Academy, Department of Radiology, Warsaw, Poland

Contact e-mail:wojpw@cskwam.mil.pl

Ovarian cancer (OVC) is usually treated with debulking surgery and than followed by systemic chemotherapy (SChTh). This SChTh has given high percent of response, but is still the problem achieving long disease-free survival. The aim of our study was the estimation of efficacy of the OVC primary SChTh consisting of carboplatin (CBDCA), cyclophosphamide (CTX), epirubicin (EPI) with concomitant intraperitoneal carboplatin. 32 women with OVC (FIGO II-IV), 70-90% Karnofsky's score has been enrolled. Median age was 54,5 years (range, 38-77 years). They received a modified regimen consisting of: CTX-600mg/m² i.v., EPI-50mg/m² i.v., CBDCA-400mg/m² i.v. plus intraperitoneal CBDCA - 20-40% dose i.v. (50-400 mg). Median dose of CTX was 916mg, CBDCA-614mg, EPI-70mg, intraperitoneal CBDCA-181mg. After the surgery all patients received 207 cycles of SChTh (median 6,5 [range 3-9 cycles] per patient). All investigated women have been assessed with typical imaging techniques, hematological and biochemical parameters and levels of serum marker - Ca-125. Toxicity was assessed using the WHO score schedule. Moreover, laparoscopic assessment of peritoneal cavity was done when 3 and 6 SChTh cycles were completed. In the group of 32 patients 47% (15) CR, 44% (14) PR, 6% (2) SD and 3% (1) PD was observed. Overall response rate of 91% (29 females) was observed. Among patients with FIGO II status have been achieved 5 CR and 1 PR, FIGO III-9 CR, 11 PR, 2 SD, 1 PD; FIGO IV-1 CR, 2 PR. Median duration of response was 22,7 months (range 1-60+ months). Median survival was 33, 86 months (range 0-65+ months). Among the total estimated number of 133 SChTh cycles we have noticed 40 cases (33%) hematologic toxicities (3rd and 4th WHO degree). Forty cycles have required G-CSF or GM-CSF support. In 2 cases SChTh was stopped of severe hematologic toxicities. These results indicate an important role of SChTh combined with intraperitoneal chth in patients with OVC after debulking surgery.

P 806

Akt activation induced by lysophosphatidic acid and sphingosine-1-phosphate requires both MEK and p38 MAP kinase and is cell-line specific

Y Xu, L M Baudhuin, K L Cristina

Cleveland Clinic Foundation, Cancer Biology, OHIO, United States

Contact e-mail:xuy@ccf.org

Akt is an anti-apoptotic protooncogene whose levels are elevated in several types of cancer. Here, we report that two bioactive lysolipids, lysophosphatidic acid (LPA) and sphingosine-1-phosphate (S1P) activate Akt and promote its phosphorylation at S473 and T308. This phosphorylation is dependent on both phosphatidylinositol 3-kinase (PI3-K) and the pertussis toxin (PTX)-sensitive Gi protein. We show, with the use of both pharmacological and genetic inhibitors, that the kinase activity and S473 phosphorylation of Akt requires both mitogen-activated protein kinase (MEK) and p38 MAP kinase, and MEK is likely to be upstream of p38 in this pathway, in HEY ovarian cancer cells. The requirement for both MEK and p38 is cell type- and stimulus-specific. Among twelve cell lines that we tested, eleven of them respond to LPA and S1P and all of the responsive cell lines require p38, but only nine of them require MEK for LPA/S1P-induced Akt phosphorylation. Among different stimuli tested, platelet-derived growth factor (PDGF) stimulates S473 phosphorylation of Akt in a MEK- and p38-dependent manner. However, epidermal growth factor (EGF), thrombin, and endothelin-1 (Et-1)-stimulated Akt S473 phosphorylation require p38, but not MEK. Insulin, on the other hand, stimulates Akt S473 phosphorylation independent of both MEK and p38 in HEY cells. T308 phosphorylation stimulated by LPA/S1P requires MEK, but not p38 activation. MEK and p38 activation were sufficient for Akt S473, but not T308, phosphorylation in HEY cells. In contrast to S1P and PDGF, LPA requires Rho for Akt S473 phosphorylation, and Rho is upstream of PI3-K. LPA/S1P-induced Akt activation may be involved in cell survival, since LPA and S1P treatment in HEY ovarian cancer cells results in a decrease in paclitaxel-induced caspase-3 activity in a PI3-K/MEK/p38-dependent manner.

P 807

Review of 63 ovarian cancer cases in Lagos, Nigeria

E R Ola, O Bello, O O Abudu

lagos university teaching hospital, obgyn, lagos, Nigeria

Contact e-mail:rotimiola@hotmail.com

Background: Incidence of ovarian cancer is not only increasing but survival remains poor and in our environment sufficient data is lacking. Objectives: This study aims to determine the frequency of occurrence of ovarian cancer in LUTH, the clinicopathological pattern of the disease, treatment modalities and outcome after a six months follow-up period. Materials and methods: Cases of ovarian cancer managed at the oncology unit LUTH between January 1988 and December 1998 were reviewed. Clinical data including demographic, clinical presentation and management modalities were collated and analysed. Results where appropriate were subjected to chi-square analysis. Results: 63 cases of ovarian cancer were reviewed giving a yearly incidence of 5.7 per year. 45.5% of the patients were over 50 years, and 36.3% were in less than 40 years, 51.5% were Para 5+ and 27.3% Para 0. Clinical presentations were abdominal swelling 84.8%, abdominal pain 60.6% and significant weight loss in 39.4% 64.5% of the cases were in advanced stage and 25.8% Stage I. Serous cystadenocarcinoma seen in 54.5% and endodermal sinus tumour 18.2%. 48.4% had complete surgery, oophorectomy 36.4%. Inoperable cases staging and biopsy only 15.2%. All the patients had post-operative che-

AACR American Association for Cancer Research

93rd Annual Meeting

April 6-10, 2002 • San Francisco, California

Volume 43 • March 2002

In joint sponsorship with the Keck School of Medicine of the University of Southern California

The premier meeting for cancer research in the post-genomic era

Featuring the latest developments in basic, translational, and clinical cancer research

Proceedings

#1011 Sphingosine-1-phosphate-mediated activation of Akt through Edg-3 and Edg-5, but not Edg-1 or Edg-8, requires activation of platelet-derived growth factor receptor. Yan Xu and Linnea Baudhuin. *Cleveland Clinic Foundation, Cleveland, OH.*

Sphingosine-1-phosphate is present in the serum and ascites of patients with ovarian cancer. It is thought to play an important role in invasion, metastasis, and overall survival of many types of cancer. We investigated a signaling pathway leading to the activation of the anti-apoptotic oncogene, Akt, in a panel of cancer cell lines treated with sphingosine-1-phosphate (S1P). S1P treatment transiently activated Akt, and its activation was suppressed by pretreatment with inhibitors of the platelet-derived growth factor receptor (PDGFR), suggesting that activation of PDGFR tyrosine kinase was involved in the signaling pathway. This crosstalk between PDGFR and S1P was specific to S1P, and did not occur when cells were treated with lysophosphatidic acid (LPA). Furthermore, S1P did not require the epidermal growth factor receptor or the insulin-like growth factor receptor for activation of Akt. S1P also was dependent on PDGFR for phosphorylation of ERK, whose upstream activator, MEK, is required for Akt activation by S1P and PDGF in certain cellular systems. We show that S1P can induce tyrosine phosphorylation of PDGFR. Both S1P and PDGF required Src for Akt activation, and Src was downstream of PI3-K and upstream of ERK. When CHO cells were overexpressed with Edg1, 3, 5, and 8, S1P required PDGFR for Akt activation in CHO-Edg-3 and -Edg-5 cells, but not CHO-Edg-1 or Edg-8 cells, indicating that PDGFR-dependent S1P-induced Akt activation was mediated through Edg-3 and Edg-5. Due to

#255 The role of ether-linked lysophosphatidic acids in ovarian cancer cells. Yan Xu, Jun Lu, Yi-Jin Xiao, Linnea Baudhuin, and Guiying Hong. *Cleveland Clinic Foundation, Cleveland, OH.*

Naturally occurring alkyl- and alkenyl-lysophosphatidic acids (al-LPAs) are detected and elevated in ovarian cancer ascites, compared with ascites from non-malignant diseases. Here we describe the biological functions and signaling properties of these ether-linked LPAs in ovarian cancer cells. They are elevated and stable in ovarian cancer ascites, which represents an *in vivo* environment for ovarian cancer cells. They stimulated DNA synthesis and proliferation of ovarian cancer cells. In addition, they induced cell migration and the secretion of a pro-angiogenic factor, interleukin-8 (IL-8), in ovarian cancer cells. The latter two processes are potentially related to tumor metastasis and angiogenesis, respectively. Al-LPAs induced diverse signaling pathways in ovarian cancer cells. Their mitogenic activity depended on the activation of the Gi/o protein, phosphatidylinositol-3 kinase (PI3K), and mitogen-activated protein (MAP) kinase kinase (MEK), but not p38 MAP kinase. The S473 phosphorylation of Akt by these lipids required activation of the Gi/o protein, PI3K, MEK, p38 MAP kinase, and Rho. On the other hand, cell migration induced by al-LPAs depended on activities of the Gi/o protein, PI3K, and Rho, but not MEK. These data suggest that ether-linked LPAs may play an important role in ovarian cancer development.

CURRICULUM VITAE

Yan Xu

Home Address: 2744 Kersdale Road
Pepper Pike, OH 44124
(216) 765-0168

Work Address: Department of Gynecology and Obstetrics
Department of Cancer Biology, NB40
The Lerner Research Institute
Cleveland Clinic Foundation
Cleveland, Ohio 44195
(216) 444-1168 (Tel)
(216) 445-6269 (Fax)
e-mail: xuy@ccf.org

Immigration Status:
American Citizen

EDUCATION

Ph.D. Biochemistry, State University of New York at Albany, USA, 1988

B.Sc. Biology, Beijing Normal University, P.R.China, 1982

MEMBERSHIP

Active member of American Association for Cancer Research
Regular member of American Society for Biochemistry and Molecular Biology
Member of American Association for the Advancement of Science
Member of American Society for Pharmacology and Experimental Therapeutics (ASPET)
Member of New York Academy of Sciences
Member of Society of Chinese Bioscientists in America (SCBA)
Member of American Chemical Society
Member of Ray Wu Society (a society for Chinese principal investigators in USA)

RESEARCH EXPERIENCE

1/00-present Associate Staff (Molecular Biology, Cell Biology and Biochemistry)
Department of Cancer Biology and Department of Gynecology and Obstetrics at the Cleveland Clinic Foundation, Cleveland, Ohio

6/1997-1999 Assistant Staff (Molecular Biology, Cell Biology and Biochemistry)
Department of Gynecology and Obstetrics and Department of Cancer Biology at the Cleveland Clinic Foundation, Cleveland, Ohio
A principal investigator (ovarian cancer research)

9/1993-6/1997 Project Scientist (Molecular Biology, Cell Biology and Biochemistry)
Department of Cancer Biology at the Cleveland Clinic Foundation, Cleveland, Ohio
An investigator (Role of Lysophospholipids and a novel G protein coupled receptor (OGR1) in Ovarian Cancer)

9/1991-8/1993 Research Scientist (Protein/Lipid Chemistry, Molecular Biology and Cell Biology)
Allelix Biopharmaceuticals Inc., Mississauga, Ont., Canada
A project leader (Purification of an unknown growth factor found in ascites from ovarian cancer patients)

4/1991-8/1991 Research Associate (Molecular Biology and Biochemistry)
The Hospital for Sick Children, Toronto, Ont. Canada
(The role of the U4/U6 snRNP and the PRP4 protein in pre-mRNA splicing in yeast)

5/1988-3/1991 Postdoctoral Fellow (Molecular Biology)
University of Toronto and The Hospital for Sick Children, Toronto, Ont., Canada
(The role of the U4/U6 snRNP in pre-mRNA splicing in yeast)

11/1987-5/1988 Research Assistant (Biochemistry and Biophysics)
University City Science Center Institute for Structural and Functional Studies, Philadelphia, PA, USA
(Mechanisms of the respiratory chain)

8/1983-11/1987 Research Assistant (Biochemistry)
State University of New York at Albany, Albany, NY, USA
(Mechanisms of the respiratory chain; purified and characterized two components in the respiratory chain)

8/1982-8/1983 Research Assistant (Biochemistry)
Iowa State University, Ames, IA, USA
(cAMP-dependent protein kinase)

GRANTS (As the PI)

8/1/02-1/31/02 Novel Lipid Signaling Pathways in Ovarian Cancer Cells (\$45,454)
Charlotte Geyer Foundation

2002-2006 NIH RO1 "Novel lipid receptors in growth regulation" (\$200,250/year direct cost) (4/1/02-3/31/06)

2002-2003 "Role of novel bioactive lipid receptor in cancer" The Ralph C. Wilson, sr. and Ralph C. Wilson, Jr. medical research foundation (\$200,000) (1/102-12/31/03)

2002-2004 NHI RO1 "structure-function analysis of a novel family of lipid receptors" (\$175,000/year direct cost) (12/1/01-11/30/04)

2001 Pacific Ovarian Cancer research Consortium "The Clinical Implication of Lysophosphatidic Acid" \$58,908 (6/1/01-5/31/02)

2000-2001 NIH R21: "A new method for the early detection of ovarian cancer" (\$222,000) (1/20/00-11/30/01)

1999-2002 DOD, "Development of a highly sensitive and specific method for the early detection and strategy for the early intervention of ovarian cancer" (\$459,332) (9/1/99-8/31/2002)

1999 Lynn Cohen Foundation (\$100,000)

1999-2001 ACS, "The Role of Lysophosphatidic Acid (LPA) in Ovarian Cancer" (\$375,000) (1/1/99-12/31/2002)

1999-2000 Sponsored Research from Atairgin (\$140,000/year) (1/1/99-12/31/2000)

1999-2000 Research founding "Mechanism of LPA production" Malcolm Hewitt Wiener Foundation, New York (\$20,000)

1997-1999 ACS, OHIO division: "Role of a Novel G Protein Coupled Receptor in Ovarian and Breast Cancer" (\$20,000) (5/1/97-4/30/1999)

1997-1999 ACS Research Opportunity Grant "The Diagnostic Significance of Lysophosphatidic Acid in Ovarian Cancer" (\$75,000) (11/1/97-10/31/99)

1996-1999 The Foster Memorial Fund to support research on female malignancies (\$30,000) (11/1/97-10/31/99)

1995 ACS Institutional Grant "Evaluation of Ovarian Cancer Activating Factor (OCAF) for Its Diagnostic or Prognostic Significance in Ovarian Cancer" (\$10,000) (1995)

HONORS AND AWARD

2002 18th International Cancer Congress Travel Award from American Cancer Society (\$2,000), 2002

1999 Northern OHIO Achievement Award in Health Care and Medicine

1993 Patent Incentive Program Award: Awarded company shares in recognition of the inventorship of a U.S. patent application by Allelix Biopharmaceuticals Inc.

1991-1993 Natural Science and Engineering Research Council (NSERC) Fellowship, Canada

1988-1990 RESTRACOM Research Fellowship from the Hospital for Sick Children, Toronto

1982 China and the United States Biochemistry and Molecular Biology Examination and Application Program (CUSBEA) Exchange Student

1978-1982 Outstanding Student Fellowship from Beijing Normal University

PROFESSIONAL EXPERIENCE

1999,2000,2002 Ad hoc member, DOD " Ovarian Cancer Research Program"

1998-present Review Committee for Institutional ACS grant, Cleveland Clinic Foundation

1999-2000 Search Committee for Clinical Chemists in the Department of Chemistry at Cleveland State University

1997-present Graduate student committees (Shen Z, Baudhuin LM, Zheng, S, and Liang, S)

TRAINEES AND TRAINING PROGRAM

Zhongzhou Shen (Ph.D student, graduated in July, 1998). Title of the thesis "Lysophosphatidic acid (LPA) as a potential marker for ovarian cancer"

Linnea Baudhuin (Ph.D student, 1998-2002) Title of the thesis "Lysophospholipid signaling through their G protein coupled receptors"

Desmond Nugent (postdoctoral fellow, 1997)

Weihua Wu (postdoctoral fellow, 1997-1998)

Ashoke Bhattacharjee (postdoctoral fellow, 1997-1998)

Kui Zhu (postdoctoral fellow, 1998-2001)
 Guiying Hong (postdoctoral fellow, 1998-present)
 Yijin Xiao (postdoctoral fellow, 1998-2001; Research Associate, 2/2002-present)
 Bei Hu (Research Associate, 1999)
 Karen Keaton (Research Nurse, 1997-1999)
 Monique Washington (Research Nurse, 1999-present)
 Benjamin Schwartz (Clinical Fellow, 1999-2000)
 Freager Willams (Clinical Fellow, 2000-2001)
 Jun Lu (postdoctoral fellow, 2000-present)
 Kelly Christina (Technologist, 2001-present)
 Li Song (Technologist, 2000-present)
 Kwan-sik Kim (visiting scientist) (2002-2003)
 Alexander Zaslavsky ((Ph.D student, 2002-present)
 Saubhik Sengupta (postdoctoral fellow, 2002-present)
 Michael Berk (Lead Technologist, 2002-present)
 Janice Battistuta (Ph.D. student, 2002-present)
 Ying Jiang (Postdoctoral Fellow, 2002-present)
 Juan Ren (Postdoctoral Fellow, 2002-present)

LIST OF PUBLICATIONS

Peer-reviewed publications

1. Baudhuin LM, Kristina KL, Lu, J, and Xu Y. Activation induced by LPA and S1P requires both MEK and p38 MAP kinase and is cell-line specific. *Mol Pharmacol* 62, 660-671, 2002.
2. **Xu Y.** Sphingosylphosphorylcholine and lysophosphatidylcholine: G protein coupled receptors and receptor-mediated signal transduction. *Biochem Biophys Acta*, 1582, 81-88, 2002.
3. Lu J, Xiao Y, Baudhuin LM, Hong G, and **Xu, Y.** Role and Signaling Pathways of Ether-linked Lysophosphatidic Acids in Ovarian Cancer Cells. *J. Lipid Res.* 43, 463-476, 2002.
4. Zhu, K., Baudhuin, L., Hong, G. Williams, F.S., Cristina, K.L., Kabarowski, J.H.S., Witte, O.N. and **Xu, Y** Sphingosylphosphorylcholine and lysophosphatidylcholine are ligands for the G protein coupled receptor, GRP4. *J Biol Chem.* 276(44):41325-41335, 2001.
5. Shen Z, Wu M, Elson P, Belinson J, Kennedy A, Markman M, Casey G, **Xu Y.** Comparison of fatty acid compositions in plasma lysophosphatidic acid from patients with cancers and healthy women controls. *Gyn. Oncol.* 83, 25-30, 2001.
6. Kabarowski JHS, Zhu K, Le LQ, Witte ON, **Xu Y.** Lysophosphatidylcholine as a Ligand for the Immunoregulatory Receptor G2A. *Science* 293, 702-705 2001
7. Schwartz BM, Hong, G, Morrison BH, Wu W, Baudhuin LM, Xiao Y. and **Xu Y.** Lysophospholipids Increase Interleukin-8 (IL-8) Expression in Ovarian Cancer Cells. *Gyn Oncol* 81, 291-300, 2001
8. Xiao Y, Schwartz B, Washington M, Kennedy A, Webster K, Belinson J. and **Xu Y.** Electrospray Ionization Mass Spectrometry Analysis of Lysophospholipids in Human Ascitic Fluids: Comparison of the Lysophospholipid Contents in Malignant vs. Non-malignant Ascitic Fluids. *Anal Biochem.* 290, 302-313, 2001.
9. **Xu Y,** Xiao, Y, Baudhuin LM, Schwartz BM. The role and clinical applications of bioactive lysolipids in ovarian cancer. *J. Soc. Gyn. Invest* 8,1-13, 2001.

10. **Xu Y**, Zhu K, Hong G, Wu W, Baudhuin LM, Xiao Yj, Damron DS. Sphingosylphosphorylcholine is a ligand for ovarian cancer G-protein-coupled receptor 1. *Nat Cell Biol.* 2, 261-267, 2000.
11. Nugent D, **Xu Y**. Sphingosine-1-phosphate: characterization of its inhibition of platelet aggregation. *Platelets* 11, 226-232, 2000.
12. Xiao Y, Chen Y, Kennedy AW, Belinson J, **Xu Y**. Evaluation of plasma lysophospholipids for diagnostic significance using electrospray ionization mass spectrometry (ESI/MS) analyses. *Ann.NY.Acad.Sci.*905,242-259,2000.
13. Nugent D, Belinson J, **Xu Y**. The synergistic interactions of oleoyl-lysophosphatidic acid in platelet aggregation. *Med Sci Res* 27,435-441, 1999.
14. Hong G, Baudhuin L, **Xu Y**. Sphingosine-1-phosphate modulates growth and adhesion of ovarian cancer cells. *FEBS Lett.*460, 513-518, 1999.
15. **Xu Y**, Shen Z, Wiper DW, Wu M, Morton RE, Elson P, Kennedy AW, Belinson, J, Markman M, Casey G. Lysophosphatidic acid as a potential biomarker for ovarian and other gynecologic cancers. *JAMA* 280, 719-723, 1998.
16. Shen Z, Belinson J, Morton RE, Xu Y, **Xu Y**. PMA stimulates LPA secretion from ovarian and cervical cancer cells, but not from breast cancer and leukemia cells. *Gynecol. Oncol.*71, 364-368.1998.
17. **Xu Y**, Casey G. Identification of human OGR1, a novel G protein coupled receptor that maps to the chromosome 14. *Genomics* 35, 397-402.1996
18. **Xu Y**, Gaudette DC, Boynton J, Frankel A, Fang X-J, Sharma A, Hurteau J, Casey G, Goodbody AE, Mellors A, Holub BJ Mills G. (1995) Characterization of an Ovarian Cancer Activating Factor(OCAF) in Ascites from Ovarian Cancer Patients. *Clinical Cancer Res.* 1, 1223-1232. 1995.
19. **Xu Y**, Fang X-J, Casey G, Mills G. Lysophospholipids Activate Ovarian and Breast Cancer Cells. *Biochem. J.* 309, 933-940. 1995.
20. **Xu Y**, Casey G, Mills G. Effects of Lysophospholipids on Signaling in the Human Jurkat Cell Line. *J. Cell. Physiology* 163, 441-450. 1995.
21. Hu J, Xu D, Schappert K, **Xu Y**, Friesen J. Mutational Analysis of *Saccharomyces cerevisiae* U4 snRNA Identifies Functionally Important Domains, *Mol. Cell Biol.* 15, 1274-1285. 1995.
22. Hu J, **Xu Y**, Schappert K, Harrington T, Wang A, Braga R, Mogridge J, Friesen J. Mutational Analysis of the PRP4 Protein of *Saccharomyces cerevisiae* Suggests Domain Structure and snRNP Interactions. *Nucleic Acid Res.* 22, 1724-1734. 1994.
23. **Xu Y**, Petersen-Bjorn S, Friesen J. The PRP4 (RNA4) Protein in *Saccharomyces cerevisiae* Is Associated with the 5' Portion of the U4 snRNA. *Mol. Cell. Biol.* 10, 1217-1225. 1990.
24. Salerno JC, **Xu Y**, Osgood MP, Kim CH, King TE. Thermodynamics and Spectroscopic Characteristics of the Cytochrome bcl Complex. *J. Biol. Chem.* 264, 15398-15403.1989.
25. **Xu Y**, Salerno JC, Wei YH, King TE. Stabilized Ubisemiquinone in Reconstituted Succinate Ubiquinone Reductase. *Biochem. Biophys. Res. Commun.* 144, 315-322. 1987

Book chapters:

1. Xu Y, Xiao Y, Zhu K, Baudhuin LM, Lu J, Hong G, Kim K-s, Cristina KL, Song L, Williams FS, Elson P, and Belinson J. Unfolding the pathophysiological role of bioactive lysophospholipids. Current drug targets-immune, endocrine & metabolic disorders. In press

2. Bauhuin L, Xiao Y, and **Xu Y**. SPC/LPC receptors Handbook of Cellular Signaling. In press.
3. Kabarowski JH, **Xu Y**, Witte ON. Lysophosphatidylcholine as a ligand for immunoregulation. *Biochem Pharmacol* 64,161-167. 2002.
4. **Xu Y**, Demron D, Calcium mobilisation in ovarian cancer by lysophospholipids. *Methods in Molecular Medicine: Ovarian Cancer: Methods and protocols.* (Ed. JMS Bartlett) Human Press Inc. Totowa, New Jersey. pp611-619. 2000
5. **Xu Y**, Fang X, Furui T, Sasagawa T, Pustilnik T, Lu Y, Shen Z, Wiener JR, Shayesteh L, Gray JW, Bast Jr RC, Mills G. Regulation of growth of ovarian cancer cells by phospholipid growth factors. *In Ovarian Cancer 5* (Sharp F, Mason P, Blackett T, Berek J.), Chapman and Hall Medical, London, Glasgow, Weinheim, New York, Tokyo, Melbourne, and Madras, pp109-120. 1997
6. **Xu Y**, Mills G. Activation of Human Ovarian Cancer Cells: Role of Lipid Factors in Ascitic Fluid. *In Ovarian Cancer 3* (Sharp F, Mason P, Blackett T, Berek J, eds.), pp. 121-135, Chapman and Hall Medical, London, Glasgow, Weinheim, New York, Tokyo, Melbourne, and Madras.1994
7. King TE, **Xu Y**. QP-S, The Electron Acceptor of Succinate Dehydrogenase. *In Cytochromes Systems: Molecular Biology and Bioenergetics* (Papa S, Chance B, Ernster L. eds.), pp503-508, Plenum Press, New York and London. 1987
8. Salerno JC, **Xu Y**. Aspects of Spin Coupling Between Odd and Even Electron Systems: Applications to Succinate Q Reductase. *In Cytochromes Systems: Molecular Biology and Bioenergetics* (Page S, Chance B, Ernster L, eds.), pp.467-471, Plenum Press, New York and London. 1987
9. King TE, **Xu Y**, Wang TY, Ding WH. A Mitochondrial Coenzyme Q protein -- QP-C. *In Biomedical Clinical Aspects of Coenzyme Q*, Vol. 5 (Folkers K, Yamamura Y. eds.), pp85-95. (1986)

PATENTS

1. **Xu Y**, Xiao, Y. US patent 6,451,609 9/17/2002; Method of Detecting Gynecological Carcinomas
2. **Xu Y**, Casey G.Gaudette DC, Holub BJ, Mills GB. US patent 5,994,141. 11/30/99; Method of Detecting Gynecological Carcinomas
3. **Xu Y**, Casey G. US patent 5,824,555. 10/20/98 Method of Detecting Gynecological Carcinomas
4. **Xu Y**, Goodbody, A. Canadian patent 1994 Ovarian Cancer Activating Factor
5. **Xu Y**, Goodbody, A. US patent # 5,326,690. 7/5/1994 Ovarian Cancer Ascites Factor in Isolated Form
6. **Xu Y**, Goodbody A, US patent # 5,277,917. 1/11/1994 Ovarian Cancer Ascites Factor in Isolated Form

MANUSCRIPTS IN PREPARATION

1. Baudhuin LM and **Xu Y**. Sphingosine-1-phosphate-mediated activation of Akt through S1P₂, but not S1P₁, requires the activation of platelet-derived growth factor receptor. In preparation.

ABSTRACTS AND CONFERENCE PRESENTATIONS:

1. Sengupta S, Xiao Y, and **Xu Y**. Production of Lysophosphatidic Acid (LPA) by Laminin - Integrin Interaction is the key for Laminin induced Ovarian Cancer cell Migration. AACR meeting San Francisco Dec. 14-19, 2002
2. Sengupta S, Xiao Y, and **Xu Y**. Production of Lysophosphatidic Acid (LPA) by Laminin - Integrin Interaction is the key for Laminin induced Ovarian Cancer cell Migration. 22nd Annual Research Day at the Cleveland Clinic Foundation. Oct. 17, 2002.
3. Hong G and **Xu Y**. OGR1 overexpression modulates cell-cell and cell-matrix interactions and induce cell apoptosis. 22nd Annual Research Day at the Cleveland Clinic Foundation. Oct. 17, 2002
4. Xiao X, Schwartz B, Fife D, While A, Kennedy A, Belinson J, and Xu Y. Analyses of LPA in peritoneal washings enhances of the sensitivity and specificity of ovarian cancer early detection. 22nd Annual Research Day at the Cleveland Clinic Foundation. Oct. 17, 2002
5. Baudhuin LM and Xu Y. Activation of Akt by LPA and S1P is Dependent on the Activaties of both ERK and p38 MAP kinases in HEY Ovarian Cancer Cells. 18th UICC International Cancer Congress (6/30-7/7/02 Oslo, Norway). Int. J. Cancer Supplemt 13, P 806, 2002
6. **Xu Y** and Baudhuin LM. Sphingosine-1-phosphate-mediated activation of Akt through Edg-3, but not Edg-1, requires the activation of platelet-derived growth factor receptor. AACR 93rd Annual meeting, p1011 (April 6-10, 2002, San Francisco, CA)
7. **Xu Y**, Lu J, Xiao Y, Baudhuin LM, and Hong G. Role and Signaling Pathways of Ether-linked Lysophosphatidic Acids in Ovarian Cancer Cells. AACR 93rd Annual meeting, p255 (April 6-10, 2002, San Francisco, CA)
8. Baudhuin L and **Xu Y**. Activation of Akt by LPA and S1P in HEY ovarian cancer cells. CCF Retreat Maumee Bay, OH (9/10/01)
9. Hong G, Xiao Y and **Xu Y**. OGR1-mediated ligand internalization of OGR1-induced apoptosis. CCF Retreat Maumee Bay, OH (9/10/01)
10. Baudhuin L and **Xu Y**. Activation of Akt by LPA and S1P in HEY ovarian cancer cells. FASEB Summer Research Conference-Lysophospholipids and Related Bioactive Lipids in Biology & Diseases. Tucson, AZ (6/10/01)
11. Baudhuin L and **Xu Y**. Activation of Akt by LPA and S1P in HEY ovarian cancer cells. American Association for Clinical Chemistry 2001 Annual Meeting and Clinical Expo, Chicago (8/1/01)
12. Lu J, Xiao Y and **Xu Y**. Roles of Ether-linked Lysophosphatidic Acid in Ovarian Cancer Cells. FASEB Summer Research Conference-Lysophospholipids and Related Bioactive Lipids in Biology & Diseases. Tucson, AZ (6/10/01)
13. Hong G, Xiao Y and **Xu Y**. OGR1-mediated ligand internalization of OGR1-induced apoptosis. FASEB Summer Research Conference-Lysophospholipids and Related Bioactive Lipids in Biology & Diseases. Tucson, AZ (6/10/01)
14. Baudhuin L and **Xu Y**. Activation of Akt by LPA and S1P in HEY ovarian cancer cells is dependent on the activities of ERK and p38 MAP kinases. 2001 AACCC/SCC Meeting 7/19-8/2/01, Chicago IL.
15. Zhu K. and **Xu Y**. Identification of the first two high affinity receptors for Sphingosylphosphorylcholine (SPC) and the first receptor for Lysophosphatidylcholine (LPC) (2001 ASBMB meeting; 3/31-4/4/01, Orlando, FA)
16. Xiao Y, Song, L, Schwartz B Washington M, Kennedy A, Webster K, Belinson B, and **Xu Y**. Alkyl and Alkenyl Lysophosphatidic Acid are elevated in peritoneal washings of patients with early and late stage ovarian Cancer (2001 ASBMB meeting; 3/31-4/4/01, Orlando, FA) (#191.1, pA200)

17. Hong G. and **Xu Y.** Overexpression OGR1 induces apoptosis (AACR 92th Annual Meeting (April 1-5, 2001) #1622, p301.
18. Xiao Y, Schwartz B, Washington M, Kennedy A, Webster K, Belinson J. and **Xu Y.** Electrospray Ionization Mass Spectrometry Analysis of Lysophospholipids in Human Ascitic Fluids: Comparison of the Lysophospholipid Contents in Malignant vs. Non-malignant Ascitic Fluids (2000 CCF Retreat, 9/10/00; Research Day; 10/15/00).
19. Zhu K, Baudhuin LM, Hong G, **Xu Y.** Sphingosylphosphorylcholine (SPC) and lysophosphatidylcholine (LPC) are ligands for GRP4 (2000 CCF Retreat, 9/10/00; Research Day; 10/15/00).
20. Lu J, Zhu K, **Xu Y.** Biological Effects of Alkyl- and Alkenyl-lysophosphatidic Acids in Ovarian Cancer Cells (2000 CCF Retreat, 9/10/00).
21. Hong G. **Xu Y.** The Dual Effect of Sphingosine-1-Phosphate on Cell Migration (2000 Research Day, 10/15/00).
22. Baudhuin LM, **Xu Y.** Up-regulation and Activation of Akt2 by Bioactive Lysolipids in Ovarian Cancer (2000 Research Day, 10/15/00).
23. **Xu Y,** Zhu K, Hong G, Wu W, Baudhuin LM, Xiao Yj, Damron DS. Sphingosylphosphorylcholine is a ligand for ovarian cancer G-protein-coupled receptor 1. IBC's 5th Annual International Conference on GPCR (a platform presentation) (May 15-16, 2000).
24. **Xu Y,** Xiao Y, Baudhuin L, Schwartz B, Hong G, Washington M, Kennedy A, Webster K, Belinson J. Ascitic fluids from ovarian cancer patients contain significantly higher levels of lysophospholipids, compared with ascites from patient with non-malignant diseases Proc. AACR 91th Annual Meeting #5463 (April 1-5, 2000).
25. Schwartz B, Hu B, Wu W, Baudhuin L, Kennedy A, Webster K, Markman M, Belinson, J. and **Xu Y.** Regulation of interleukin-8 production and gene expression in human ovarian cancer cells by lysophospholipids. Proc. AACR 91th Annual Meeting #3727 (April 1-5, 2000).
26. Schwartz B. **Xu Y.** Bioactive lysolipids upregulates interleukin-8 production and gene expression in human ovarian cancer cells. The Smithkline Beecham National Oncology Fellows Forum (Selected platform presentation; Feb. 24-27, 2000).
27. Hong G, Baudhuin L, **Xu Y.** Sphingosine-1-phosphate modulates growth and adhesion of ovarian cancer cells. 1999 Research Institute Retreat, the Cleveland Clinic Foundation, Ohio (September 13-15, 1999).
28. Xiao Y, Chen Y, Kennedy AW, Belinson J, **Xu Y.** Evaluation of plasma lysophospholipids for diagnostic significance using electrospray ionization mass spectrometry (ESI/MS) analyses. Research Institute Retreat, the Cleveland Clinic Foundation, Ohio (September 13-15, 1999).
29. CSU student seminar Baudhuin L, Hong G, **Xu Y.** Sphingosine-1-phosphate modulates growth and adhesion of ovarian cancer cells.
30. Hong G, Baudhuin L, Xu Y. Sphingosine-1-phosphate modulates growth and adhesion of ovarian cancer cells. at The 1st Cancer Research Meeting. The Cancer Center, Cleveland Clinic Foundation (April 24, 1999).
31. Mills G, Fang XJ, Furui T, Mao M, Weiner J, Estrenica V, **Xu Y.** Lysophosphatidic acid (LPA) in early diagnosis, prognosis and therapy of ovarian cancer. First Annual International Conference on Ovarian Cancer. Houston TX (Feb. 3-5, 1999).
32. **Xu Y,** Wu W, Belinson J. OGR1 in ovarian and breast cancer. G Protein Coupled Receptors-Therapeutic Advancement and Applications. Orlando, FL (October 5-7, 1998).
33. **Xu Y,** Shen Z, Wu M, Wiper C, Morton R, Elson P, Kennedy A, Belinson J, Markman M, Casey G. lysophosphatidic acid as a biomarker for ovarian and other gynecological cancers. Gordon Research Conference, Salve Regina University, Newport, RI (August 2-7, 1998).

34. **Xu Y**, Shen Z, Xu Y. LPA as a marker for ovarian cancer. An invited talk at the 30th Central Regional Meeting of the American Chemical Society. Cleveland, OH (May 27 to May 29, 1998).
35. Shen Z, Wu M, Wiper DW, Morton RE, Kennedy AW, Belinson J, Markman M, Xu Y, Casey G **Xu Y**. (1997) Assessment of plasma lysophosphatidic acid for early detection of ovarian cancer by gas chromatography. Eastern Analytical Symposium, Somerset, New Jersey (Nov. 16-21, 1997).
36. Shen Z, Wu M, Wiper DW, Morton RE, Kennedy AW, Belinson J, Markman M, Casey G, **Xu Y**. Evaluation of lysophosphatidic acid as a diagnostic marker for ovarian and other gynecological cancers. 49th AACC Annual Meeting & Clinical Laboratory Exposition. Atlanta, Georgia (July 20-24, 1997).
37. Shen Z, Wu M, Wiper DW, Morton RE, Kennedy AW, Belinson J, Markman M, Xu Y, Casey G. **Xu Y**. Lysophosphatidic acid, a diagnostic biomarker for ovarian and other gynecological cancers. 7th Society of Chinese Bioscientists in America (SCBA) International Symposium, Toronto, Canada, (July 6-11, 1997).
38. **Xu Y**, Wu M, Shen Z, Wiper DW, Morton RE, Kennedy A, Belinson J, Markman M, Casey G. Lysophosphatidic acid, a diagnostic biomarker for ovarian and other gynecological cancers. 88th Annual Meeting for the American Association for Cancer Research, San Diego, CA. (April 12-16, 1997) Proc of AACR, #710, 1997.
39. **Xu Y**, Casey G (1996) A Novel G Protein Coupled Receptor in Ovarian and Breast Cancer. ASBMB Meeting/ASBMB Satellite Meeting, New Orleans, Louisiana (Lipid Second Messengers). (June 1-5, 1996).
40. **Xu Y**, Casey G. A Novel G Protein Coupled Receptor in Ovarian and Breast Cancer (a platform presentation) 1st World Congress on Advances in Oncology, Athens, Greece. (Oct. 24, 1995).
41. **Xu Y**, Casey G. A Novel G Protein Coupled Receptor in Ovarian and Breast Cancers. The Cleveland Clinic Foundation Research Institute Retreat, (Sept. 10-12, 1995).
42. **Xu Y**, Casey G, Mills, G. Ovarian Cancer Activating Factor (a platform presentation) The Cleveland Clinic Foundation, Research Institute Retreat. (Sept. 11-13, 1994).
43. **Xu Y**, Casey G, Mills G. Isolation and Characterization of an Ovarian Cancer Activating Factor (OCAF). The Cleveland Clinic Foundation Research Day presentation at the Cleveland Clinic Foundation. (Oct. 1, 1994).
44. **Xu Y**, Mills G. Ovarian Cancer Activating Factor (a platform presentation). The Second Symposium on Life Science and Biotechnology for Chinese Bio-scientists Overseas and Returned. Beijing, P.R. China (June 24-28, 1994).
45. **Xu Y**, Gaudette DC, Boynton J, Sharma A, Goodbody AE, Mellors A, Holub BJ, Mills G. Characterization of an Ovarian Cancer Activating Factor(OCAF) in Ascites from Ovarian Cancer Patients. The Keystone Symposia "Lipid as Second Messenger". Taos, New Mexico (Feb.26-March 4, 1994).
46. **Xu Y**, Goodbody A, Boynton J, Mills G. OCAF, A Unique Lipid Mediator in Ascites from Ovarian Cancer Patients. The 2nd Meeting on Signal Transduction in Normal and Cancer Cells. March, Banff, Canada. (1993).
47. **Xu Y**, Schappert K, Harrington T, Braga R, Friesen JD. Mutagenesis of the PRP4 Protein of *S. cerevisiae*.(an invited talk).Cold Spring Harbor Laboratory RNA processing Meeting and abstract, p22 (1991).
48. Hu J, Schappert K, **Xu Y**, Friesen JD. (1991) Genetic and Biochemical Analysis of Yeast U4 snRNA. Cold Spring Harbor Laboratory RNA Processing Meeting Abstract p137.(1991).
49. **Xu Y**, Friesen JD. *In vitro* Assembly of the *S. cerevisiae* PRP4 Protein-Containing-U4 snRNA Complex. Cold Spring Harbor Laboratory RNA Processing Meeting Abstract p298.(1990).

50. **Xu Y**, Petersen-Bjorn S, and Friesen JD. PRP4 (RNA4) Associates with the 5' Portion of U4 and/or the 3' Portion of U6 snRNAs. Cold Spring Harbor Laboratory RNA Processing Meeting Abstract p267.(1989).
51. **Xu Y**, Salerno JC, Wei YH, King TE. EPR Behavior of Reconstituted Succinate Ubiquinone Reductase. Feb. Proc. 46:232. (1987).
52. King TE, **Xu Y**. Preparation and Properties of QP-S. Fed. Proc. 46:231.(1987)

TALKS/PRESENTATION:

1. "Role and signaling pathways of lysophospholipids in cancer" (an invited talk at Mayo Clinic) (9/24/02)
2. "Biomarker detection in breast cancer" Breast cancer conference, The Taussig Cancer Center, 9/19/02.
3. "Bioactive lysophospholipids, their receptors, and cancers" The Netherlands Cancer Institute, Amsterdam, Netherlands, (7/8/02)
4. "Receptors for SPC and LPC" (an invited talk at the Annual Meeting GERLI 2000) (4/18/01) Nantes, France.
5. "Role of signaling pathways of lysophospholipids in cancer" (an invited talk in the Department of Pathology, Case Western Research University) (4/29/02).
6. "Role of signaling pathways of lysophospholipids in cancer" (ICOS LLC; Alameda, CA; 2/25/02).
7. "Role of signaling pathways of lysophospholipids in cancer" (Department of Pharmacology, Case Western Reserve University; 2/21/02).
8. "The potential pathological roles of LPA in ovarian cancer" (an invited talk at the 74th Annual Meeting of the Japanese Biochemical Society; 10/27/01).
9. "G protein coupled receptors for LPC and SPC" (a talk at the CCF Retreat; Maumee Bay, OH; 9/11/01).
10. "G protein coupled receptors for LPC and SPC" (Beijing University, Beijing, P.R. China; 9/25/01).
11. "Role of signaling pathways of lysophospholipids in cancer" (Institute of Animal, The Chinese Academy of Science; Beijing, P.R.China; 9/28/01).
12. "Role of signaling pathways of lysophospholipids in cancer" (Beijing Normal University, P.R.China; 10/5/01).
13. "Bioactive lysophospholipids in cancers" Renal Cell Carcinoma SPORE Committee meeting (7/12/01; CCF).
14. "Bioactive lysophospholipids in cancers" (a talk at the Special Symposium: finding a cure to glioblastoma (6/23-6/24/01, CCF).
15. G protein coupled receptors for SPC and LPC (an invited talk at 2001 FASEB Summer Research Conference-Lysophospholipids and Related Bioactive Lipids in Biology & Diseases. Tucson, AZ (6/10/01).
16. The potential clinical applications of lysolipids (an invited talk at Pacific Ovarian Cancer Research Consortium (POCRC) Scientific Seminar (4/17/01).
17. Lysolipids and their receptors (a talk at the Department of anesthesiology at CCF (1/30/01).
18. OGR1 and GPR4 are receptors for SPC and LPC (an invited talk at receptors at the Howard Hughes Medical Institute, UCLA (10/12/00).
19. Bioactive lipids and their receptors in ovarian cancer (an invited talk at University of Virginia, Charlottesville; Sept. 6, 2000).
20. Sphingosylphosphorylcholine is a ligand for ovarian cancer G-protein-coupled receptor 1. IBC's 5th Annual International Conference on GPCR (a platform presentation) (May 15-16, 2000).
21. Ascitic fluids from ovarian cancer patients contain significantly higher levels of lysolipids, compared with ascites from patients with non-

- malignant diseases (Society of Gynecologic Investigation-2000, Ovarian Cancer Symposium, Chicago; March 22, 2000).
22. Lysolipids in ovarian cancer (a talk at the Cancer Center, Cleveland Clinic Foundation; 2/23/00).
 23. Dedication CME Program for Community Physicians on June 27th: Lysolipids and their receptors in ovarian cancer (Cancer Center at Cleveland Clinic Foundation; 6/27/00).
 24. LPA, a potential marker for the early detection of ovarian cancer (a talk for fund raising at the Cleveland Clinic Foundation; Sept. 28, 1999).
 25. The molecular biology of cervical cancer (a talk on the Shanxi Province Evaluation of plasma lysophospholipids for diagnostic significance using electrospray ionization mass spectrometry (ESI/MS) analyses. (an invited talk at "Lysophospholipids and eicosanoids in cancer and in cardiovascular and neurodegenerative diseases". New York, NY (June 25-28, 1999).
 26. The early detection of ovarian cancer (a selected and invited talk on the American Cancer Society's 41 st Science Writers Seminar, March 28-30, 1999. Miami, FL.
 27. LPA as a potential biomarker for ovarian and other gynecological cancers. ACS meeting (Regional) (an invited talk) May 28, 1998. Cleveland, OH.
 28. Role of lysophospholipids in ovarian cancer (Cancer Center) Dec. 16, 1998
The potential role of lysophospholipids in cancer (an invited talk) Department of Chemistry at the Cleveland Clinic Foundation, Feb. 27, 1998.
 29. The potential role of lysophospholipids in cancer (an invited talk) Cell Biology at the Cleveland Clinic Foundation, Feb. 13, 1998.
 30. The potential role of lysophosphatidic acid (LPA) in cancer (an invited talk) The Anesthesia Research Center at the Cleveland Clinic Foundation, Dec. 4, 1996.
 31. The potential role of lysophosphatidic acid (LPA) in cancer (an invited talk) MD Anderson, July 19, 1996.
 32. A G Protein Coupled Receptor in Ovarian Cancer (Department Seminar) The Cleveland Clinic Foundation, Jan. 16. 1996.
 33. Ovarian Cancer Activating Factor and its Signaling Pathways. Zhejiang University, Hangzhou, P.R.China, July 9, 1994.
 34. Ovarian Cancer and Ovarian Cancer Activating Factor. Beijing University, Beijing, P.R. China, June 30, 1994.
 35. Lysophospholipids activate human ovarian and leukemia cells. Qinghua University, Beijing, P.R. China, June 22, 1994.
 36. Lysophospholipids and Ovarian Cancer. Beijing Normal University, Beijing, P.R. China, June 29, 1994.
 37. Ovarian Cancer Activating Factor. Cancer Center, The Cleveland Clinic Foundation, June 7, 1994.
 38. Isolation and characterization of an Ovarian Cancer Activating Factor in Ascites from Ovarian Cancer Patients. Department of Gynecology, The Cleveland Clinic Foundation, Dec. 1993.
 39. Ovarian Cancer Ascites Factor (OCAF), a Novel Lipid Mediator in Ascites of Ovarian Cancer Patients. The Cleveland Clinic Foundation, Cleveland, USA, April 27, 1993

CONFERENCES ATTENDED:

- 2002 18th International Cancer Congress Travel Award from American Cancer Society (June 30-July 4/2002)
- 2002 The Annual Meeting GERLI 2000 (4/18/01) Nantes, France.
- 2001 The 74th Annual Meeting of the Japanese Biochemical Society (10/24-10/28/01)

- 2002 FASEB Summer Research Conference-Lysophospholipids and Related Bioactive Lipids in Biology & Diseases. Tucson, AZ (June 9-14, 2001)
- 2000 Research Institute Retreat, the Cleveland Clinic Foundation, Ohio (September 10-12, 2000)
- 2000 IBC's 5th Annual International Conference on GPCR (May 15-16, 2000).
- 2000 Society of Gynecologic Investigation-2000, Chicago (March 22, 2000)
- 2000 American Association for Cancer Research 91th Annual meeting San Francisco, CA (April 1-5, 2000)
- 1999 Research Institute Retreat, the Cleveland Clinic Foundation, Ohio (September 13-15, 1999)
- 1999 Lysophospholipids and eicosanoids in cancer and in cardiovascular and neurodegenerative diseases. New York, NY (June 25-28, 1999)
- 1999 The 1st Cancer Research Meeting. The Cancer Center, Cleveland Clinic Foundation (April 24, 1999)
- 1999 American Association for Cancer Research 90th annual meeting. Phila, PA (April 10-14, 1999)
- 1999 American Cancer Society's 41 st Science Writers Seminar. Miami, FL. (March 28-30, 1999)
- 1999 First annual international Conference for ovarian cancer. Houston, TX (Feb. 3-5, 1999)
- 1998 G Protein Coupled Receptors-Therapeutic Advancement and Applications. Orlando, FL (October 5-7, 1998)
- 1998 Research Institute Retreat, the Cleveland Clinic Foundation, Ohio (September 13-15, 1998)
- 1998 Gordon Research Conference, Salve Regina University, Newport, RI (August 2-7, 1998)
- 1997 7th Society of Chinese Bioscientists in America (SCBA) International Symposium, Toronto, Canada. (July 6 to July 11, 1997)
- 1997 American Association for Cancer Research (AACR) 88th Annual Meeting, San Diego, CA (April 12-16, 1997)
- 1995 Research Institute Retreat, the Cleveland Clinic Foundation, Ohio (September 1996)
- 1996 ASBMB Meeting/ASBMB Satellite Meeting, New Orleans, Louisiana (Lipid Second Messengers) (June 1-June 5, 1996)
- 1995 1st World Congress on Advances in Oncology, Athens, Greece (Oct. 22-26, 1995).
- 1995 Research Institute Retreat, the Cleveland Clinic Foundation, Ohio (September. 10-12, 1995)
- 1994 Research Institute Retreat, the Cleveland Clinic Foundation, Ohio (September. 11-13, 1994)
- 1994 The Keystone Symposia "Lipid as Second Messenger", Taos, NM USA (Feb. 26-March 4, 1994)
- 1993 Research Institute Conference, the Cleveland Clinic Foundation, Bratenahl, Ohio, Nov., 1993
- 1993 The 2nd Meeting on Signal Transduction in Normal and Cancer Cells, Banff, Canada (April 1-5, 1993)
- 1992 Eighth International Symposium on Cellular Endocrinology "Growth Factors: Signal Transduction Mechanism and Role in Development" Lake Placid, NY USA (August 31-September 3, 1992)
- 1991 Cold Spring Harbor Laboratory RNA Processing Meeting, Cold Spring Harbor, NY USA (May 15-19, 1991)
- 1990 XVIth International Congress of Genetics, Toronto, ON Canada
- 1990 Cold Spring Harbor Laboratory RNA Processing Meeting, Cold Spring Harbor, NY USA (May 16-20, 1990)

- 1989 Cold Spring Harbor Laboratory RNA Processing Meeting, Cold Spring Harbor, NY USA
1987 Annual Meeting for American society of Biological Chemists, Philadelphia, PA USA (June 7-11, 1987)
1985 Electron Transfer Conference, Albany, NY USA

REFERENCES

- Prof. Bryan Williams Chairman, Department of Cancer Biology
 Cleveland Clinic Foundation
 9500 Euclid Ave.
 Cleveland, OH 44195
 (216) 445-9652 (Tel)
 (216) 445-6269 (Fax)
 e-mail: willab@ccf.org
- Jerome Belinson, MD. Department of Gynecology and Obstetrics
 Cleveland Clinic Foundation
 9500 Euclid Ave.
 Cleveland, OH 44195
 (216) 444-7933 (Tel)
 (216) 444-8551 (Fax)
 e-mail: belinsj@ccf.org
- Maurie Markman, M.D. Director, Cancer Center
 Cleveland Clinic Foundation
 9500 Euclid Ave.
 Cleveland, OH 44195
 (216) 445-6888 (Tel)
 (216) 444-9464 (Fax)
 e-mail: @ccf.org



US006451609B1

(12) **United States Patent**
Xu et al.

(10) Patent No.: **US 6,451,609 B1**
(45) Date of Patent: **Sep. 17, 2002**

- (54) **METHOD OF DETECTING GYNECOLOGICAL CARCINOMAS**
- (75) Inventors: **Yan Xu, Pepper Pike; Yijin Xiao, Cleveland, both of OH (US)**
- (73) Assignee: **The Cleveland Clinic Foundation, Cleveland, OH (US)**
- (*) Notice: Subject to any disclaimer, the term of this patent is extended or adjusted under 35 U.S.C. 154(b) by 0 days.
- (21) Appl. No.: **09/448,800**
- (22) Filed: **Nov. 24, 1999**

Related U.S. Application Data

- (63) Continuation-in-part of application No. 09/139,841, filed on Aug. 25, 1998, now Pat. No. 5,994,141, which is a continuation of application No. 08/655,551, filed on May 30, 1996, now Pat. No. 5,824,555.
- (51) Int. Cl.⁷ **G01N 33/48**
- (52) U.S. Cl. **436/64; 436/813**
- (58) Field of Search **436/64, 813**

(56) **References Cited**

U.S. PATENT DOCUMENTS

4,999,344 A	3/1991	Jett-Tilton et al.
5,277,917 A	1/1994	Xu et al.
5,326,690 A	7/1994	Xu et al.
5,595,738 A	1/1997	Pomato et al.
5,824,555 A	10/1998	Xu et al.
5,994,141 A	11/1999	Xu et al.

FOREIGN PATENT DOCUMENTS

WO WO 98/43093 * 10/1998

OTHER PUBLICATIONS

Translation of abstract of article by Misako Okita, *Bulletin of the department of health and welfare*, Okayama Prefectural University, vol. 1-1, pp. 29-35, 1994.

- "Effect of Lysophospholipids on Signaling in the Human Jurkat T Cell Line" by Xu, et al., *Journal of Cellular Physiology*, 163:441-450 (1995).
- "Lysophospholipids activate ovarian and breast cancer cells" by Xu, et al., *Biochem. J.*, (1995) 309, 933-940.
- "Characterization of an Ovarian Cancer Activating Factor in Ascites from Ovarian Cancer Patients" by Xu, et al. *Clinical Cancer Research*, vol. 1, pp. 1223-1232, Oct. 1995.
- "Growth factor-like effects of lysophosphatidic acid, a novel lipid mediator" by Jalink, et al., *Biochimica et Biophysica Acta*, 1198 (1994) 185-196.
- "Lysophosphatidic Acid, a Multifunctional Phospholipid Messenger" by Mooleenaar, *The Journal of Biological Chemistry*, vol. 270, No. 2, pp. 12949-12952, Jun. 2, 1995.
- "Lysophosphatidic acid possesses dual action in cell proliferation" by Tigyi, et al., *Proc. Natl. Acad. Sci. USA*, vol. 91, pp. 1908-1912, Mar. 1994.

(List continued on next page.)

Primary Examiner—Jill Warden

Assistant Examiner—Monique T. Cole

(74) Attorney, Agent, or Firm—Calfee, Halter & Griswold LLP

(57) **ABSTRACT**

Methods for detecting or diagnosing gynecological carcinomas in a patient are provided. One method The method, which involves assaying for the presence of lysophosphatidic acid in a plasma sample of the patient, is useful for detecting ovarian carcinoma, cervical carcinoma, endometrial carcinoma, and peritoneal carcinoma. In a preferred embodiment the method comprises: providing a blood specimen from the patient, obtaining a plasma sample for the blood specimen under conditions which minimize the release of lysophosphatidic acid from the platelets in the blood specimen into the plasma, extracting lipids from the plasma, and detecting the presence of lysophosphatidic acid in the lipid. Another method involves assaying for the presence of lysophosphatidyl inositol in a bodily fluid, preferably plasma, from the subject.

5 Claims, 2 Drawing Sheets

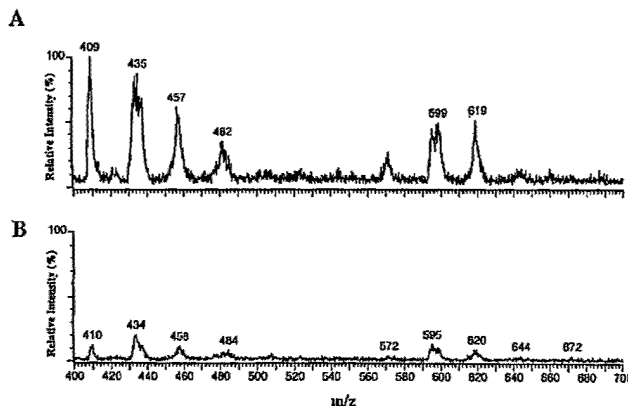

OTHER PUBLICATIONS

- "Decanoyl lysophosphatidic acid induces platelet aggregation through an extracellular action" by Watson, et al., *Biochem. J.*, (1985) 232, pp. 61-66.
- "LPA: a novel lipid mediator with diverse biological actions" by Moolenaar, *Trends in Cell Biology*, vol. 4, pp. 213-218, Jun. 1994.
- "Increased phosphatidic acid and decreased lysophosphatidic acid in response to thrombin is associated with inhibition of platelet aggregation" by Gerrard, et al., *Biochem. Cell Biol.*, vol. 71, pp. 432-439, 1993.
- "Lysophosphatidic Acid as a Potential Biomarker for Ovarian Cancer and Other Gynecological Cancers" by Xu, et al., *The Journal of the American Medical Association*, vol. 280, No. 8, pp. 719-723, Aug. 26, 1998.
- "Peptide and Lipid Growth Factors Decrease cis-Diamminedichloroplatinum-induced Cell Death in Human Ovarian Cancer Cells" by Frankel, et al., *Clinical Cancer Research*, vol. 2, pp. 1307-1313, Aug. 1996.
- "Role of Growth Factors: Their Receptors and Signalling Pathways in the Diagnosis, Prognosis, Follow-Up and Therapy of Ovarian Cancer" by Mills, et al., *Diagn Oncol*, 1992;2:39-54.
- "Phorbol 12-Myristate 13-Acetate Simulates Lysophosphatidic Acid Secretion from Ovarian and Cervical Cancer Cells but Not from Breast or Leukemia Cells" by Shen, et al., *Gynecologic Oncology*, 71, 364-368 (1998).
- "Elevated Levels and Altered Fatty Acid Composition of Plasma Lysophosphatidylcholine (LYSOPC) in Ovarian Cancer Patients" by Okita, et al., *Int. J. Cancer*, 71, 31-34 (1997).
- "Activation of human ovarian cancer cells: role of lipid factors in ascitic fluid" by Xu, et al., Chapman & Hall Medical, London, Glasgow, Weinheim, New York, Tokyo, Melbourne, Madras, pp. 121-135 (1994).
- "Malignant effusions contain lysophosphatidic acid (LPA)-like activity" by Westermann, et al., *Annals of Oncology*, 9, pp. 437-442 (1998).
- "Soluble Interleukin-2 Receptor Alpha is Elevated in Sera of Patients with Benign Ovarian Neoplasms and Epithelial Ovarian Cancer" by Hurteau, et al., *Cancer*, vol. 76, No. 9, pp. 1615-1620, Nov. 1, 1995.
- "A Putative New Growth Factor in Ascitic Fluid from Ovarian Cancer Patients: Identification, Characterization, and Mechanisms of Action" by Mills, et al., *Cancer Research*, 48, 1066-1071, Mar. 1, 1988.
- "Ascitic Fluid from Human Ovarian Cancer Patients Contains Growth Factors Necessary for Intraperitoneal Growth of Human Ovarian Adenocarcinoma Cells" by Mills, et al., *J. Clin. Invest.*, vol. 86, pp. 851-855, Sep., 1990.
- "Levels of soluble interleukin-2 receptor- α are elevated in serum and ascitic fluid from epithelial ovarian cancer patient" by Hurteau, et al., *Am J Obstet Gynecol*, vol. 170, No. 3, pp. 918-928, Mar. 1994.
- "Lysophosphatidylcholine Stimulates Activator Protein 1 and the c-Jun N-terminal Kinase Activity" by Fang, et al., *The Journal of Biological Chemistry*, vol. 272, No. 21, pp. 13683-13689, May 23, 1997.
- "Induction of In Vitro Tumor Cell Invasion of Cellular Monolayers by Lysophosphatidic Acid or Phospholipase D" by Imamura, *Biochemical and Biophysical Research-Communications*, vol. 193, No. 2, pp. 497-503, Jun. 15, 1993.
- "Analysis of the Proliferative Response to Lysophosphatidic Acid in Primary Cultures of mammary Epithelium: Differences between Normal and Tumor Cells" by Imagawa, et al., *Experimental Cell Research*, 216, 178-186 (1995).
- "The bioactive phospholipid acid is released from activated platelets" by Eichholtz, et al., *Biochem J.*, 291, (1993), pp. 677-680.
- "Lysophosphatidic acid: G-protein signalling and cellular responses" by Moolenaar, et al., *Cell Regulation*, pp. 168-173.
- Abstract #710, "Lysophosphatidic acid, a diagnostic biomarker for ovarian and other gynecological cancers" by Xu, et al., *Proceedings of the American Association for Cancer Research*, vol. 38, Mar. 1997, p. 106.
- "Abnormality in plasma lysophosphatidic acid of ovarian cancer patients" by Okita, et al., *Bulletin of the department of health and welfare*, Okayama Prefectural University, vol. 1-1, 1994, pp. 29-35.

* cited by examiner

Fig. 1

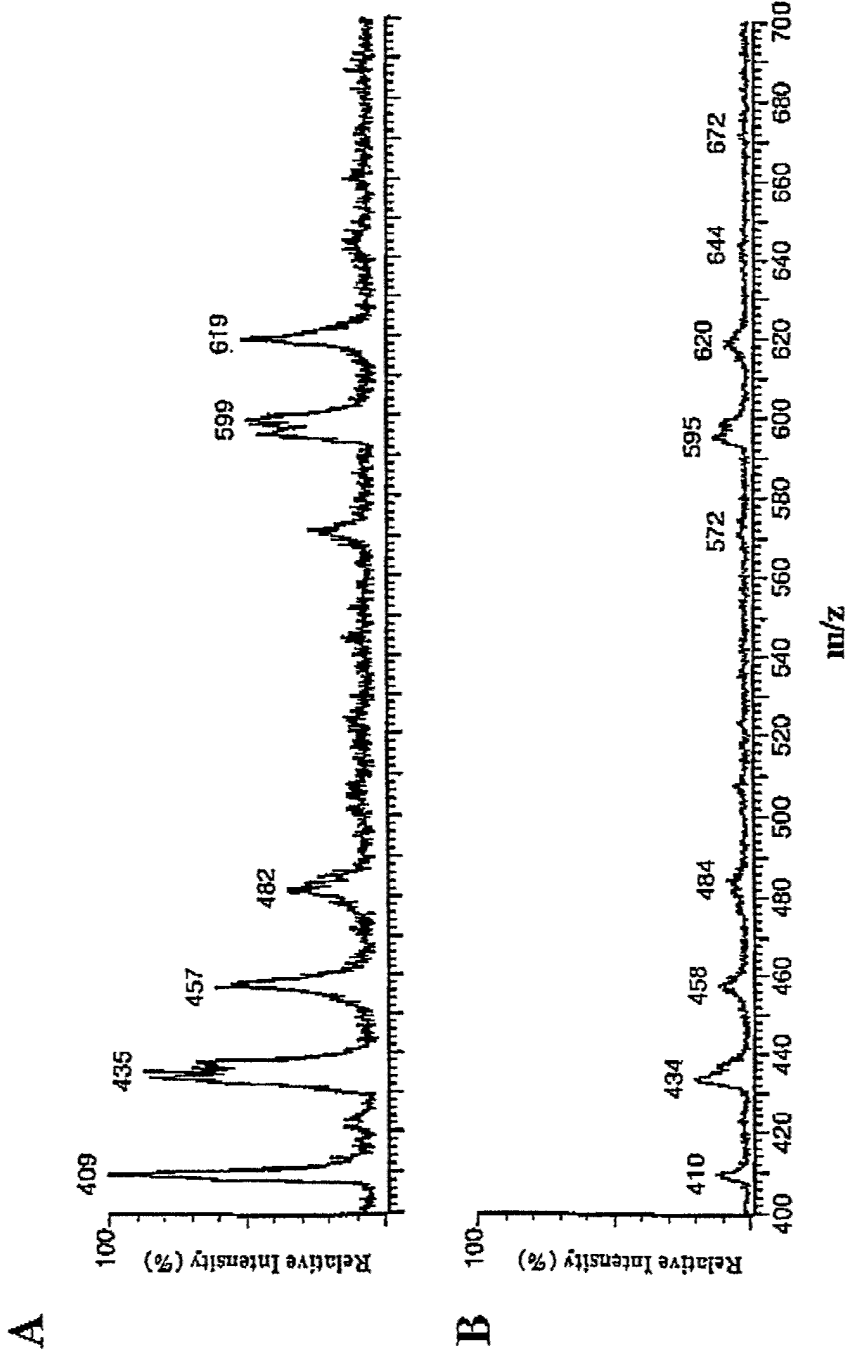
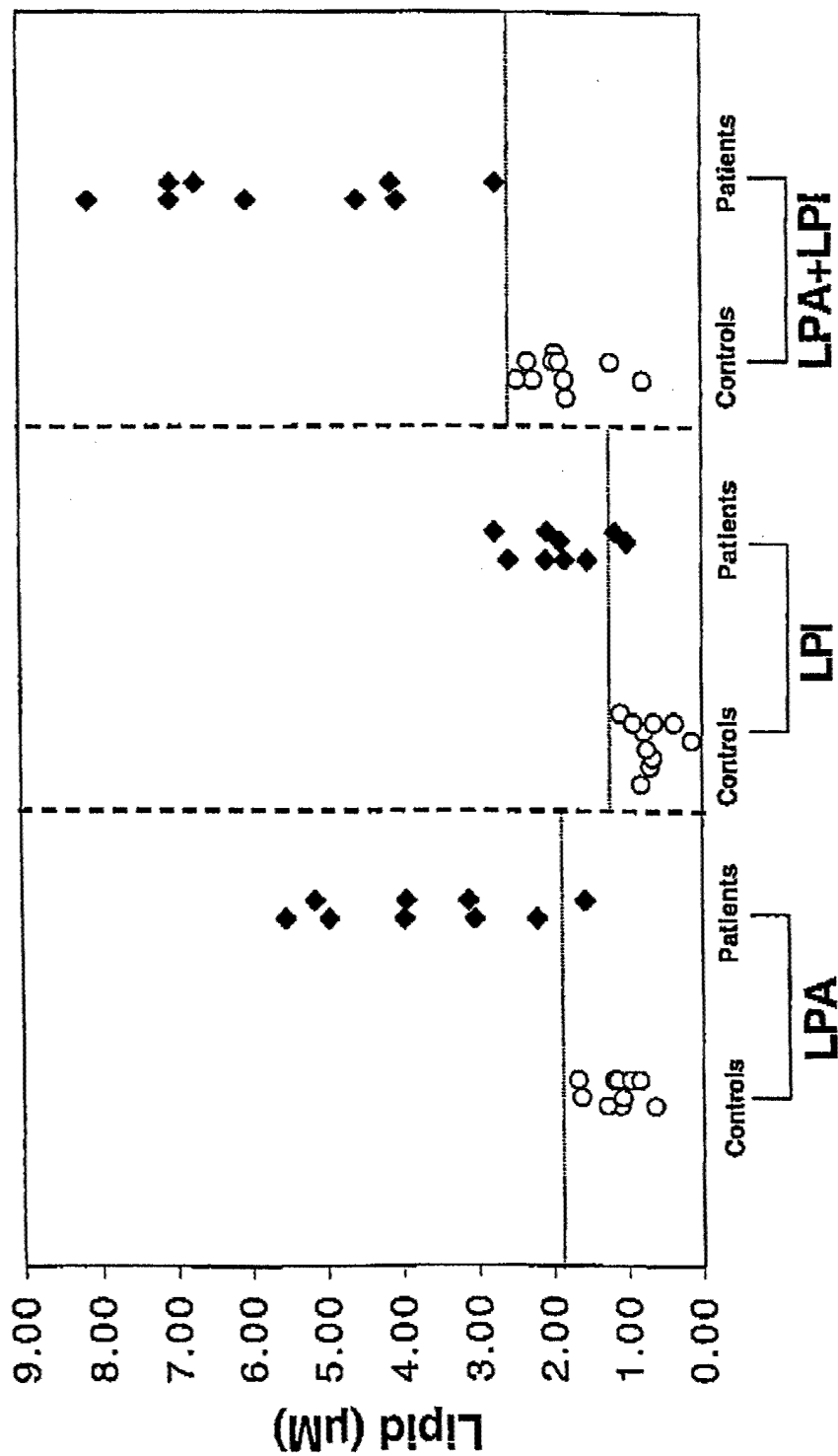

Fig. 2



1

**METHOD OF DETECTING
GYNECOLOGICAL CARCINOMAS
CROSS REFERENCE TO RELATED
APPLICATIONS**

This application is a continuation-in-part of U.S. application Ser. No. 09/139,841 filed on Aug. 25, 1998, now U.S. Pat. No. 5,994,141, which is a continuation of the U.S. application Ser. No. 08/655,551, filed on May 30, 1996, now U.S. Pat. No. 5,824,555.

BACKGROUND OF THE INVENTION

Gynecological carcinomas such as ovarian carcinoma, cervical carcinoma, endometrial carcinoma and peritoneal carcinoma are among the most frequent causes of cancer death among women in the United States and Europe. It is estimated that ovarian carcinoma alone will be responsible for 14,800 deaths in 1996 in the United States. This dismal outcome is due, at least in part, to an inability to detect the ovarian carcinoma at an early stage of tumor development. When ovarian carcinoma is diagnosed at an early stage, the cure rate approaches 90%. In contrast, the 5 year outlook for women with advanced disease remains poor with no more than a 15% survival rate. Thus, early diagnosis is one of the most effective means of improving the prognosis for ovarian carcinoma.

Transvaginal sonography is the most sensitive of the currently available techniques used for detecting ovarian tumors. However, transvaginal sonography is non-specific, i.e. it will detect benign as well as malignant tumors. Accordingly, detection of an ovarian tumor by transvaginal sonography must be followed by a second diagnostic procedure which is able to distinguish benign tumors from malignant tumors. Moreover, transvaginal sonography is very expensive and, therefore, not useful as a screening procedure for large numbers of patients.

Typically, benign ovarian tumors are distinguished from malignant ovarian tumors by surgical procedures such as biopsy of the mass or aspiration of the mass and cytological examination of the cells that are surgically removed from the patient. However, these techniques are highly invasive, expensive, and in the case of aspiration can lead to release of cancerous cells into the peritoneum.

The antigenic determinant CA 125, which is a high molecular weight mucin-like glycoprotein, is the current serum biomarker of choice for screening for ovarian carcinomas. However, CA 125 testing suffers from two main limitations. First of all, it is not very sensitive. For example, elevated serum CA 125 levels, i.e. levels above the cut-off point of 35 U/ml, are present in fewer than 50% of the patients with Stage I ovarian carcinoma. Taylor, K. J. W. and Schwartz, P. E., "Screening for Early Ovarian Cancer," *Radiology*, 192:1-10, 1994. In addition, CA 125 testing is not very specific. For example, approximately 25% of patients with benign gynecological diseases also have elevated serum levels of CA 125. Moreover, liver disease such as cirrhosis, even without ascites, elevates serum CA 125 levels above 35 U/ml. Taylor, K. J. W. and Schwartz, P. E., "Screening for Early Ovarian Cancer," *Radiology*, 192:1-10, 1994.

Accordingly, it would be desirable to have a new, simple, noninvasive or marginally invasive methods for detecting gynecological carcinomas, particularly ovarian carcinomas. Methods which are sufficiently sensitive to identify those subjects with early stage ovarian carcinoma, and sufficiently specific to distinguish between benign and malignant gynecological carcinomas are especially desirable.

2

SUMMARY OF THE INVENTION

The present invention provides new, simple, marginally-invasive methods for detecting the presence of gynecological carcinomas, particularly ovarian carcinomas, in a subject.

One method comprises assaying for the presence of lysophosphatidic acid in a plasma sample. The presence of lysophosphatidic acid in the plasma sample indicates that a gynecological carcinoma is present in the subject. In a preferred embodiment, the method comprises preparing a plasma sample which is substantially free of platelets from a blood specimen from the subject, preparing a lipid extract from said plasma sample, and assaying for the presence of lysophosphatidic acid in said lipid extract. Because the method is sufficiently sensitive to detect ovarian carcinoma in subjects with early stage ovarian carcinoma, sufficiently specific to distinguish benign gynecological carcinomas from malignant gynecological carcinomas, and marginally invasive, the method is especially useful for screening patients for ovarian carcinomas. The method also detects the presence of endometrial carcinoma, peritoneal carcinoma, and cervical carcinoma in a subject. Accordingly, the method is useful for screening for more than one gynecological carcinoma.

Another method comprises assaying for the presence of lysophosphatidyl inositol in a bodily fluid, preferably a blood sample from the subject. Preferably, the concentration of the lysophosphatidyl inositol in the bodily fluid is determined.

BRIEF DESCRIPTION OF THE FIGURES

FIG. 1A show the representative mass spectra of lysophospholipids from patients with ovarian cancer (FIG. 1A) and from healthy control subjects (FIG. 1B).

FIG. 2 is a scatter plot showing total plasma LPA, LPI and LPA+LPI levels from healthy control subjects and from patients with ovarian and endometrial carcinoma.

**DETAILED DESCRIPTION OF THE
INVENTION**

The present invention provides new, simple methods for detecting or diagnosing gynecological carcinomas, particularly ovarian carcinomas, in a subject or patient. One method comprises assaying for the presence of lysophosphatidic acid in a blood plasma sample from the patient. Preferably, the blood plasma sample is substantially free of platelets. As described herein, a plasma sample is substantially free of platelets when it contains less than 95% of the platelets present in the original blood specimen obtained from the patient. In a preferred embodiment, the method comprises providing a whole blood specimen from the patient, obtaining a plasma sample which is substantially free of platelets from the whole blood specimen, extracting lipids from the blood plasma sample, and assaying for the presence of lysophosphatidic acid in the lipid extract.

Preferably, the blood plasma sample is obtained under conditions which minimize the release of lysophosphatidic acid from platelets which are present in the whole blood specimen. Such conditions include, for example, collecting the whole blood specimen from the subject in tubes that contain an anti-coagulant. Suitable anti-coagulants include, for example, heparin and chelating agents. It is preferred that the whole blood specimen be collected in the presence of a chelating agent, such as for example ethylenediaminetetraacetic acid (EDTA) or sodium citrate, more preferably EDTA, since chelating agents both reduce phospholipase

activity in the sample and prevent clotting of the whole blood specimen.

The blood plasma typically is obtained by centrifuging the whole blood specimen to pellet the blood cells in the whole blood specimen and collecting the supernatant, which represents the major portion of the blood plasma in the whole blood specimen.

Substantially all of the lipids, particularly the phospholipids, in the plasma sample are then extracted, preferably by a lipid extraction procedure which recovers at least 80% of the lysophosphatidic acid from the plasma sample. More preferably, the lipid extraction procedure recovers at least 85% of the LPA in the plasma sample. An example of a preferred lipid extraction procedure comprises the steps of: acidifying the blood plasma sample; mixing the acidified blood plasma sample with an organic solvent to provide an aqueous phase and an organic phase, wherein the phospholipids preferentially distribute to the organic phase; and recovering the organic phase to provide a lipid extract which contains greater than 80% of the lysophosphatidic acid in the plasma sample. Preferably, hydrochloric acid is used to acidify the blood plasma sample. Preferably the final concentration of acid in the acidified plasma sample is from about 0.2 N to about 2.0 N.

Suitable organic solvents for extracting lysophosphatidic acid from the acidified plasma sample include for example butanol, isopropanol, and mixed organic solvents which comprise a polar organic solvent, such as for example methanol, and a non-polar organic solvent, such as for example chloroform. Preferably the organic solvent is a mixture of methanol and chloroform at a 2:1 ratio.

The lysophosphatidic acid, also referred to herein as "LPA," is then separated from the other phospholipids in the organic phase using conventional techniques. One such technique involves separation by thin-layer chromatography to provide an LPA band.

The amount of lysophosphatidic acid in the LPA band is then quantified using conventional techniques. The quantification technique used depends upon the amount of blood specimen provided by the subject. For example, if the size of the blood specimen is 2 ml or less, it is preferred that a quantification technique which is capable of detecting picomole amounts of LPA be used. Suitable techniques for detecting picomole amounts of LPA include, for example, hydrolyzing the isolated LPA fraction and then quantifying the amount of each fatty acid in the hydrolysate by gas chromatography. If the size of the blood specimen is 20 ml or greater, a technique which is capable of detecting nanomole amounts of LPA, such as for example total phosphorous determination in the LPA fraction, is suitable.

Another method comprises assaying for the presence of lysophosphatidyl inositol (LPI) in a bodily fluid from the subject. Preferably, the bodily fluid is blood, more preferably plasma. One method of assaying for the presence of LPI in the bodily fluid involves extraction of lipids from the sample, separation of the lipids by thin-layer chromatography and direct analysis with electrospray ionization mass spectrometry (ESI-MS). This method has the following advantages: i) soft ionization detects intact molecular species and therefore the true identities of lipid molecules; ii) structures of interesting ion peaks can be determined through tandem-MS (MS/MS) or liquid chromatography/tandem mass spectrometry (LC/MS/MS) analysis; iii) it simultaneously detects many molecular species, including lipids with different fatty acid chains; iv) it is highly sensitive (typically in the femtomole to low picomole range) and v) the assay can be easily adapted to an autosampler.

Preferably, the method further comprises determining the levels or concentration of LPI in said bodily fluid. In accordance with the present invention, it has been determined that females with ovarian carcinoma have higher levels or concentrations of LPI in their plasma than healthy subjects. Preferably, the level or concentration of LPI in the bodily fluid is then compared to a standard value. The standard value is based upon the levels of LPI found in comparable samples obtained from a population of healthy subjects.

Standard values of LPI in a bodily fluid are for example, mean levels, median levels, or preferably "cut-off" levels. Cut-off values are established by assaying a large sample of healthy individuals and using a statistical model such as the predictive value method for selecting a positivity criterion or receiver operator characteristic curve that defines optimum specificity (highest true negative rate) and sensitivity (highest true positive rate) as described in Knapp, R. G., and Miller, M. C. (1992). *Clinical Epidemiology and Biostatistics*. William and Wilkins, Harual Publishing Co. Malvern, Pa., which is specifically incorporated herein by reference. Preferably, the levels of both LPA and LPI in the bodily fluid are determined. In accordance with the present invention, it has been determined that a combined test value which is based on the concentration of both LPA and LPI in plasma from the subject is a better indicator of ovarian carcinoma than a test value which is based on the concentration of LPA or LPI alone. The combined test value is compared to a combined standard value which is based on the concentrations of LPA and LPI found in plasma from healthy subjects.

The methods disclosed herein are useful for detecting gynecological carcinomas such as cervical carcinoma, endometrial carcinoma, peritoneal carcinoma, and ovarian carcinoma, that is, epithelial ovarian cancer. Epithelial ovarian cancer includes serous tumors, mucinous tumors, endometrioid tumors, clear cell tumors, undifferentiated carcinoma, mixed epithelial tumors, and unclassified epithelial tumors.

The methods disclosed herein are especially useful for assessing the malignancy of an ovarian mass in a patient and for detecting ovarian carcinomas at the early surgical stage of development in a patient, that is Surgical Stage I and Surgical Stage II, as well as at the later stages of development, that is Surgical Stage III and Surgical Stage IV. Surgical stage represents the severity of disease with Stage I being least severe and Stage IV being the most severe. According to criteria established by the International Federation of Gynecology and Obstetrics, the ovarian carcinoma is limited to the ovaries and may or may not include ascites in Stage I ovarian carcinoma. In Stage II, there is pelvic extension of the carcinoma and possibly extension to the uterus or fallopian tubes. Stage III ovarian carcinoma is characterized by abdominal metastases. In Stage IV, there is distant metastases of the carcinoma outside of the peritoneal cavity.

The methods disclosed herein are simple, marginally invasive, and require only a blood specimen from the subject. Thus, such methods are also useful for screening patients who have not been previously diagnosed as carrying carcinoma, particularly patients who are at risk for gynecological carcinomas, especially ovarian carcinoma. Such patients include women at elevated risk by virtue of a family history of the disease, premenopausal women with anovulatory cycles, and postmenopausal women.

The present invention is further described by the examples which follow. Such examples, however, are not to

be construed as limiting in any way either the spirit or the scope of the present invention.

EXAMPLE 1

Plasma samples were obtained from blood specimens provided by eighty-four female subjects. A whole blood specimen of approximately 2 ml was collected from each of the subjects in a 5 ml vacutainer tube containing 7.2 mg of EDTA.

Obtaining a Plasma Sample from the Whole Blood Specimen

The whole blood specimen was centrifuged at 580×g for 5 minutes to provide a pellet of the blood cells and platelets and a supernatant. The supernatant was transferred to a siliconized microcentrifuge tube and centrifuged for 5 minutes at 8000×g to provide a second pellet and a plasma supernatant. The plasma supernatant was either processed immediately or stored at -70° C.

Extracting LPA from a Plasma Sample

Extraction of lipids, particularly LPA from the plasma sample was performed at 0-4° C. Each 1 mL sample of plasma was acidified by adding 0.2 mL of 12 N HCl to provide a plasma sample with a final concentration of HCl of approximately 2.0 N. After mixing, 4 ML of mixed organic solvent comprising a 2:1 ratio of methanol/chloroform was added to the acidified plasma and the mixture was vortexed for 1 minute and incubated on ice for 10 minutes. 1 mL of chloroform and 1.25 mL of H₂O were added to the mixture. After mixing thoroughly, the mixture was centrifuged at 1000×g for 10 minutes at 4° C. The lower organic layer was transferred to a new glass tube and dried at 40° C. under nitrogen to provide a phospholipid extract.

The total recovery rate and reproducibility of this extraction procedure was examined by adding 10 nmol of synthetic oleoyl-LPA to three parallel plasma samples lacking endogenous oleoyl-LPA. The samples were extracted by the present procedure and the amount of oleoyl-LPA in each sample quantified. This analysis indicated that the average recovery of LPA by the present extraction procedure was 92.7% with a standard error of ±5.6%.

Isolating the LPA in the Lipid Extract

Each lipid extract was dissolved in 50 μl of a 2:1 methanol/chloroform mixture and loaded onto a single lane of a precoated silica-gel 60 TLC plate (20×20 cm, layer thickness 250 μm) obtained from EM Science, Darmstadt, Germany. A 50 μl aliquot of a 2:1 methanol/chloroform mixture containing 10 to 50 μg of oleoyl-LPA obtained from Avanti Polar-Lipids, Inc. was loaded onto one outside lane of the plate and a 50 μl aliquot of chloroform containing 10 to 50 μg of lysophosphatidylcholine obtained from Sigma Chemical Company was loaded onto the opposite outside lane of the plate. The oleoyl-LPA and lysophosphatidylcholine were used as migration references for locating the LPA fractions on the plate. The lipids were developed at room temperature for approximately 3 hours with a mixture of chloroform-methanol-ammonium hydroxide (65:35:5.5). Then the outside lanes containing the oleoyl LPA and lysophosphatidylcholine standards were sprayed with 0.1% 8-anilino-1-naphthalene-sulfonic acid and visualized under ultraviolet light.

Each of the isolated LPA fractions in the lanes loaded with lipid extracts from the plasma samples were scraped from the plates into separate 15 mL disposable glass centrifuge tubes from Kimble, Vineland, N.J. The LPA fractions included all of the lipids that migrated to a distance on the plate which corresponded to the Rf of the oleoyl-LPA standard and extended to but was less than the Rf of the lysophosphatidylcholine standard.

Measuring the Amount of LPA Isolated from Each Sample

2 mL of 1M ethanolic KOH were added to each tube containing the isolated LPA fractions. The tubes were then incubated at 60° C. for 1 hour to hydrolyze the LPA present in the tube. After cooling, 5 μl of internal standard solution contains methyl behenate, 1.5 mg/mL in chloroform, 1 mL of 6N HCl. 5 mL of H₂O and 5 mL of ethyl ether were added to the hydrolysate. The mixture was vortexed for 30 seconds and centrifuged at 1000×g for 10 minutes. Then, the upper layer was transferred into a new glass tube and dried at 40° C. under nitrogen. The residue, which contained fatty acids released from the LPA, was dissolved in 0.6 mL of petroleum ether and the dissolved, fatty acids were transmethylated by adding 1 mL of BCl₃-methanol reagent to each tube and incubating at 100° C. for 10 minutes. BCl₃ methanol was obtained from Supelco Inc., Bellefonte, Pa. The fatty acid methyl esters were extracted with 1 ml of petroleum ether. The mixture was vortexed for 10 seconds and centrifuged at 1000×g for 5 minutes. The top layer was transferred to a 3.7 mL screw-topped Supelco sample vial and dried at 40° C. under nitrogen. The residue was then dissolved in 25 μl of chloroform and 5-15 μl of the chloroform solution was used for analysis by gas chromatography.

GC Analysis of the Fatty Acids Released from LPA by Hydrolysis

A Hewlett-Packard Model 5710A gas chromatograph, equipped with a fused silica column (25 m×0.2 mm) coated with 3% SP-2310, 2% SP-2300 on 100/120 Chromosorb WAW from Supelco Inc., was used to measure the amount of each fatty acid in each of the samples. The gas chromatograph conditions were as follows: the oven starting temperature was 185° C.; after 2 minutes, the temperature was increased at 2° C./minutes to 230° C., and held for 4 minutes; the injector temperature was 200° C.; the detector temperature was 300° C.; nitrogen was the carrier gas at a flow rate of 30 ml/minutes at 50 PSI; airflow rate was 240 mu/minutes at 24 PSI; hydrogen flow was 30 ml/min at 15 Psi. A flame ionization detector was used to detect the fatty acid methyl esters. Two standard curves were obtained using two fatty acid methyl esters standard mixtures obtained from Nu Check Prep. Inc., Elysian, Minn. The two standard mixtures included different combinations of the esters of methyl palmitate, methyl stearate, methyl oleate, methyl linoleate, methyl arachidonate and methyl behenate. The retention times were 3.8 min for methyl palmitate, 6.7 min for methyl stearate, 7.3 min for methyl oleate, 8.3 min for methyl linoleate, 14.0 min for methyl arachidonate and 15.3 min for methyl behenate (internal standard).

The concentrations of each fatty acid in each sample were calculated and added together to obtain the concentration of total LPA in each plasma sample. The concentrations in μM of each LPA species and of total LPA in each of the samples are presented in Table I.

Each of the female subjects also underwent one or more routine diagnostic procedures to determine whether she was healthy or had an active disease. The diagnostic procedures included, where appropriate, clinical examination, clinical chemistries, and surgical evaluation of any masses detected. On the basis of these routine diagnostic procedures, the patients were diagnosed as being healthy or as having an active form of one of the diseases listed in Table I.

TABLE I-continued

LPA Levels (μM) in Plasma of Subjects of the Example							
Diagnosis	LPA(P)	LPA(S)	LPA(O)	LPA(L)	LPA(A)	LPA(D)	TOTAL LPA
#21	B.D.	B.D.	B.D.	B.D.	B.D.	B.D.	B.D.
#22	4.93	B.D.	B.D.	B.D.	B.D.	B.D.	4.93
#23	B.D.	B.D.	B.D.	B.D.	B.D.	B.D.	B.D.
<u>9. Benign GYN Diseases</u>							
#1	B.D.	B.D.	B.D.	B.D.	B.D.	B.D.	B.D.
#2	B.D.	B.D.	B.D.	B.D.	B.D.	B.D.	B.D.
#3	B.D.	B.D.	B.D.	B.D.	B.D.	B.D.	B.D.
<u>10. Sarcoma</u>							
#1	B.D.	B.D.	B.D.	B.D.	B.D.	B.D.	B.D.
#2	B.D.	B.D.	B.D.	B.D.	B.D.	B.D.	B.D.
#3	B.D.	B.D.	B.D.	B.D.	B.D.	B.D.	B.D.
#4	B.D.	2.08	0.99	1.43	3.48	B.D.	7.97
<u>11. Breast Cancer</u>							
#1	B.D.	B.D.	B.D.	B.D.	B.D.	B.D.	B.D.
#2	B.D.	B.D.	0.42	B.D.	B.D.	B.D.	0.42
#3	B.D.	B.D.	B.D.	B.D.	B.D.	B.D.	B.D.
#4	B.D.	B.D.	B.D.	B.D.	B.D.	B.D.	B.D.
#5	B.D.	B.D.	B.D.	B.D.	B.D.	B.D.	B.D.
#6	B.D.	B.D.	B.D.	B.D.	B.D.	B.D.	B.D.
#7	B.D.	B.D.	B.D.	B.D.	B.D.	B.D.	B.D.
#8	B.D.	B.D.	B.D.	B.D.	B.D.	B.D.	B.D.
#9	B.D.	B.D.	B.D.	B.D.	B.D.	B.D.	B.D.
#10	B.D.	B.D.	B.D.	B.D.	B.D.	B.D.	B.D.
#11	B.D.	B.D.	B.D.	B.D.	B.D.	B.D.	B.D.
<u>12. Leukemia</u>							
#1	B.D.	B.D.	B.D.	B.D.	B.D.	B.D.	B.D.
#2	B.D.	B.D.	B.D.	B.D.	B.D.	B.D.	B.D.
#3	B.D.	B.D.	B.D.	B.D.	B.D.	B.D.	B.D.
#4	B.D.	B.D.	B.D.	B.D.	B.D.	B.D.	B.D.

LPA(P): palmitoyl - LPA
 LPA(S): stearoyl - LPA
 LPA(O): oleoyl - LPA
 LPA(L): linolenyl - LPA
 LPA(A): arachidyl - LPA
 LPA(D): docosahexanyl - LPA
 B.D.: below detection
 N.A.: Not available

The average concentrations \pm SE of each LPA species in the plasma of patients diagnosed as having a gynecological carcinoma and the average concentration \pm SE of each LPA species in the plasma of patients diagnosed as not having a gynecological carcinoma are presented in Table II. The average concentrations \pm SE of total LPA in the plasma of

patients with the gynecological carcinomas and the average concentrations \pm SE of total LPA in the plasma of patients without gynecological carcinomas are presented in Table III. The statistical power calculations were performed using the Wilcoxon Rank Sum statistical test as described by W. J. Conover in Practical Nonparametric. 0.1 μM was used in calculations where LPA levels were below detection.

TABLE II

Average Concentration of Individual LPA Species in the Plasma of Subjects from the Example							
Diagnosis	N LPA	Mean	SE	SD	Median	Min	Max
Healthy	23 LPA(P)	0.33	0.21	1.01	0.10	0.10	4.93
	LPA(S)	0.21	0.08	0.40	0.10	0.10	1.94
	LPA(O)	0.10	0.00	0.02	0.10	0.10	0.21
	LPA(L)	0.10	0.00	0.00	0.10	0.10	0.10
	LPA(A)	0.10	0.00	0.00	0.10	0.10	0.10
	LPA(D)	0.10	0.00	0.00	0.10	0.10	0.10
Ovarian Carcinoma	19 LPA(P)	5.10	0.88	3.85	3.61	0.10	11.09
	LPA(S)	5.54	0.83	3.61	4.91	0.40	12.84
	LPA(O)	2.43	0.61	2.66	1.59	0.10	11.39
	LPA(L)	3.27	0.91	3.96	1.85	0.10	13.50
	LPA(A)	2.32	0.62	2.70	1.59	0.10	8.96
	LPA(D)	0.26	0.16	0.69	0.10	0.10	3.12

TABLE II-continued

Average Concentration of Individual LPA Species in the Plasma of Subjects from the Example							
Diagnosis	N	LPA	Mean	SE	SD	Median	Min Max
Peritoneal Carinoma	9	LPA(P)	4.65	1.73	5.19	3.11	0.10 14.22
		LPA(S)	4.28	1.38	4.14	3.15	0.10 11.45
		LPA(O)	2.48	1.34	4.02	0.68	0.10 12.50
		LPA(L)	3.59	1.61	4.83	2.40	0.10 14.92
		LPA(A)	1.82	0.98	2.95	0.28	0.10 9.19
		LPA(D)	0.35	0.25	0.75	0.10	0.10 2.34
Endometrial Carcinoma	7	LPA(P)	9.01	2.29	6.05	7.68	1.71 21.15
		LPA(S)	8.33	1.71	4.52	7.65	1.65 15.84
		LPA(O)	5.99	2.27	6.02	3.53	0.59 16.41
		LPA(L)	8.11	3.16	8.37	5.27	0.10 20.98
		LPA(A)	3.10	1.38	3.66	2.23	0.10 9.05
		LPA(D)	0.10	0.00	0.00	0.10	0.10 0.10
Cervical Carcinoma	4	LPA(P)	8.64	3.25	6.50	9.20	0.86 15.29
		LPA(S)	7.73	2.70	5.40	8.39	1.14 12.98
		LPA(O)	4.52	1.84	3.69	4.86	0.10 8.27
		LPA(L)	4.35	2.36	4.72	3.44	0.10 10.44
		LPA(A)	4.43	2.02	4.05	4.32	0.10 8.97
		LPA(D)	0.10	0.00	0.00	0.10	0.10 0.10
Benign Gynecological Disease	3	LPA(P)	0.10	0.00	0.00	0.10	0.10 0.10
		LPA(S)	0.10	0.00	0.00	0.10	0.10 0.10
		LPA(O)	0.10	0.00	0.00	0.10	0.10 0.10
		LPA(L)	0.10	0.00	0.00	0.10	0.10 0.10
		LPA(A)	0.10	0.00	0.00	0.10	0.10 0.10
		LPA(D)	0.10	0.00	0.00	0.10	0.10 0.10
Sarcoma	4	LPA(P)	0.10	0.00	0.00	0.10	0.10 0.10
		LPA(S)	0.60	0.50	0.99	0.10	0.10 2.08
		LPA(O)	0.32	0.22	0.45	0.10	0.10 0.99
		LPA(L)	0.43	0.33	0.67	0.10	0.10 1.43
		LPA(A)	0.95	0.85	1.69	0.10	0.10 3.48
		LPA(D)	0.10	0.00	0.00	0.10	0.10 0.10
Breast Cancer	11	LPA(P)	0.10	0.00	0.00	0.10	0.10 0.10
		LPA(S)	0.10	0.00	0.00	0.10	0.10 0.10
		LPA(O)	0.18	0.03	0.10	0.10	0.10 0.43
		LPA(L)	0.10	0.00	0.00	0.10	0.10 0.10
		LPA(A)	0.10	0.00	0.00	0.10	0.10 0.10
		LPA(D)	0.10	0.00	0.00	0.10	0.10 0.10
Leukemia	4	LPA(P)	0.10	0.00	0.00	0.10	0.10 0.10
		LPA(S)	0.10	0.00	0.00	0.10	0.10 0.10
		LPA(O)	0.10	0.00	0.00	0.10	0.10 0.10
		LPA(L)	0.10	0.00	0.00	0.10	0.10 0.10
		LPA(A)	0.10	0.00	0.00	0.10	0.10 0.10
		LPA(D)	0.10	0.00	0.00	0.10	0.10 0.10

LPA(P): palmitoyl - LPA
 LPA(S): stearoyl - LPA
 LPA(O): oleoyl - LPA
 LPA(L): linolenyl - LPA
 LPA(A): arachidyl - LPA
 LPA(D): docosahexanyl - LPA
 B.D.: below detection
 N.A.: Not available

50

TABLE III

Average Concentration of Total LPA (μ M) in the Plasma of Patients							
Diagnosis	N	Mean	SE	SD	Median	Min	Max
Healthy	23	0.45	0.23	1.09	0.10	0.10	4.93
Ovarian Carcinoma	19	18.68	3.43	14.97	14.07	2.53	56.17
Peritoneal Carcinoma	9	16.93	6.79	20.37	12.08	0.10	63.21
Endometrial Carcinoma	7	33.17	7.51	19.86	29.82	3.95	63.23
Cervical Carcinoma	4	29.58	11.83	23.67	32.57	2.00	51.19
Benign Gynecological Disease	3	0.10	0.00	0.00	0.10	0.10	0.10
Sarcoma	4	4.83	1.05	5.04	3.62	0.10	19.92
Breast Cancer	11	0.13	0.03	0.10	0.10	0.10	0.43
Leukemia	4	0.10	0.00	0.00	0.10	0.10	0.10

TABLE III-continued

Average Concentration of Total LPA (μ M) in the Plasma of Patients							
Diagnosis	N	Mean	SE	SD	Median	Min	Max
LPA(P): palmitoyl - LPA	55						
LPA(S): stearoyl - LPA							
LPA(O): oleoyl - LPA							
LPA(L): linolenyl - LPA							
LPA(A): arachidyl - LPA							
LPA(D): docosahexanyl - LPA							
B.D.: below detection	60						
N.A.: Not available							

As shown in Table I, detectable levels of total LPA were found in each of the patients with I, Stage II, Stage III or Stage IV ovarian carcinoma. Thus, every one of the patients diagnosed as having early stage ovarian carcinoma or late state ovarian carcinoma had detectable levels of LPA in her

65

plasma. No false negatives were observed in any of the patients with ovarian carcinoma. The concentration of total LPA in subjects with Stage I and Stage II ovarian carcinoma ranged from 4.67 to 32.32 μM . The concentration of total LPA in subjects with Stage III and Stage IV carcinoma ranged from 2.53 to 56.17 μM . Moreover, detectable levels of stearoyl-LPA were found in all of the patients with ovarian carcinoma and detectable levels of the LPA species palmitoyl-LPA and oleoyl-LPA were found in 18 out of the 19 patients with ovarian carcinoma.

In contrast, 19 out of the 23 subjects who were characterized as being healthy, did not have detectable levels of LPA in their plasma. The remaining four healthy patients had low concentrations of LPA in their plasma, ranging from 0.42 to 4.93 μM . It is not known whether these values represent false positives or whether these individuals had a gynecological carcinoma that was not detected by the other routine procedures used to diagnose the patients. Moreover, the average concentration of total LPA and of each LPA species in the plasma of patients diagnosed as having ovarian carcinoma was significantly higher than the average concentration of total LPA and of each LPA-species in the plasma of healthy patients. These results establish that the present method is highly sensitive and therefore useful for identifying those patients with the gynecological carcinoma of ovarian carcinoma, including those patients whose ovarian carcinomas are still in the early stages of development. The results also indicate that a method which detects the presence of palmitoyl LPA or stearoyl-LPA or oleoyl-LPA or combinations thereof in the plasma of patients is also useful for detecting ovarian carcinomas.

LPA was also detected in the plasma of every one of the subjects diagnosed as having cervical carcinoma and endometrial carcinoma, and in eight out of the nine subjects diagnosed as having peritoneal carcinoma. The peritoneal carcinoma had been totally debulked in the one patient who did not have detectable levels of LPA in her plasma. This result suggests that LPA is not present in the plasma of patients whose carcinomas are completely removed by surgery. Thus, the present method is useful for monitoring the recurrence of gynecological carcinomas in patients who have undergone surgical removal of the carcinoma. The concentration of LPA in the plasma of the subjects with cervical carcinoma and endometrial carcinoma ranged from 2.00 to 63.23 μM .

In contrast, detectable levels of LPA were not present in 15 out of the 17 patients diagnosed as having a cancer other than a gynecological carcinoma, i.e., breast cancer, leukemia, and uterine sarcoma. Moreover, detectable levels of LPA were not present in any of the subjects with uterine fibroids, a benign gynecological disease. Since plasma from three out of the four patients with gynecological sarcomas, which are derived from connective tissues, and with benign uterine fibroids did not have detectable levels of total LPA in their plasma, it is believed that malignant epithelial cells of the respective gynecological organ may be the source of the LPA in the plasma of patients with ovarian carcinoma, cervical carcinoma, endometrial carcinoma, and peritoneal carcinoma.

Because of its sensitivity, simplicity, and low cost, the present method is useful for screening patients for gynecological carcinomas. Because the blood specimens for the present method and for CA 125 testing can be drawn from a patient at the same time, CA 125 testing can also be performed when patients are screened for gynecological carcinomas by the present methods. Alternatively, the present method can be used alone to detect gynecological carcinomas.

Because the LPA is not present in the plasma of patients with benign gynecological diseases, the present method is also useful for distinguishing between gynecological diseases which are benign and gynecological diseases which are malignant in patients with gynecological masses. Use of this method to discriminate between malignant and benign ovarian masses should reduce the number of patients required to undergo the more expensive techniques such as transvaginal sonography or the more invasive techniques such as tumor biopsy or tumor aspiration that are now used to diagnose ovarian tumor malignancy.

EXAMPLE 2

Sample Collection from Patients and Healthy Controls

Samples were collected from 9 patients who were seen in the Department of Gynecology and Obstetrics at the Cleveland Clinic Foundation between February 1998 and April 1998. Whole blood specimens were obtained from 8 patients (median age, 65.0 years; range 44–72 years) with ovarian cancer, 1 patients with endometrial cancer (age 44 years), and 10 healthy controls (median age, 45.5 years, range 28–48 years). An informed consent was obtained from all participants.

All of the cancer patients had been diagnosed with cancer when blood samples were drawn. Clinical stage was determined according to the International Federation of Gynecologists and Obstetricians (FIGO) criteria, and the histological subtype was evaluated according to the WHO classification. (See Table IV below.) To prevent platelet activation and phospholipase activity, blood samples were collected in EDTA-containing tubes. Whole blood was centrifuged at 2,500 g for 15 minutes. Plasma was either processed immediately or stored at -80°C . before lipid extraction.

TABLE IV

The clinical data

Subject #	Healthy		Stage	Grade	Subtype	CA125
	Age	Conditions				
1	41	Healthy				
2	37	Healthy				
3	45	Healthy				
4	46	Healthy				
5	32	Healthy				
6	48	Healthy				
7	28	Healthy				
8	47	Healthy				
9	45	Uterine fibroids				
10	44	Uterine fibroids				
11	55		IIC	2	Endometrioid	37
12	67		IV	3	Serous	201
13	64		III	3	Endometrioid	1284
14	46		III	3	Serous	46
15	66		IIIC	3	Serous	1091
16	66		IV	3	Serous	909
17	72		III	3	Serous	11
18	61		III	3	Serous	447
19	44		III			

Subjects # 11 to 18 were patients with ovarian cancer and subject # 19 was a patient with endometrial cancer.

Reagents and Standards

LPA and other lysophospholipids, except 16:0-LPI, were purchased from Avanti Polar Lipids (Birmingham, Ala.) The LPI preparation (extracted from soybean and contains 62% 16:0-LPI; cat. #L-7635, lot #46H8390) was from Sigma (St. Louis, Mo.). Precoated silica gel 60 TLC plates were obtained from EM Science (Gibbstown, N.J.). HPLC grade

methanol (MeOH), chloroform, ammonium hydroxide (AmOH), hydrochloric acid (HCl) were purchased from Sigma (St. Louis, Mo.) or Fisher Scientific Co. (Pittsburgh, Pa.)

LPA-17:0 was purchased from Avanti in chloroform form. Known amounts of the lipid were aliquoted in a known amount and the chloroform was evaporated under N_2 at 40° C. The lipid was resuspended in methanol and 500 pmol was added to each sample before the lipid extraction. LPAs-16:0, 18:0 and 18:1 and LPI (18:0) were obtained from Avanti and standard solutions were made in methanol. To obtain standard curves, different amounts (5–300 pmol) of standard LPAs or 18:0-LPI were mixed with the same amount (50 pmol) of internal standard LPA-17:0.

Preparation of Samples

Blood samples were centrifuged at 2,500 g for 15 min at 4° C. The plasma was transferred into siliconized eppendorf tubes and frozen at –80° C. or used immediately. All extraction procedures were performed in 15 ml glass disposable centrifuge tubes (Supelco/Sigma, St. Louis, Mo.). For each 1 ml of blood sample, 0.2 ml of 6N HCl and 4 ml MeOH/Chloroform (2:1) were added. The sample was vortexed for 1 min and incubated on ice for 10 min. One ml chloroform and 1.25 ml H_2O were added to separate the phases. The samples were vortexed for 0.5 min and incubated on ice for 0.5 min. After centrifugation (2000 g for 10 min), the lower phase was transferred to a new glass tube and the solvent was evaporated under nitrogen at 40° C. in a React-Therm (Pierce, Rockford, Ill.). The dried lipids were resuspended in 501 μ L solvent (MeOH: chloroform 2:1), vortexed and applied to a TLC plate.

The silica gel 60 TLC plates were pre-run using the solvent system (chloroform:MeOH:AmOH=65:35:5.5) to remove contaminants and then dried. Samples were applied to TLC plates as a band and developed in the same solvent system. One each TLC plate, two markers: standard oleoyl-LPA (18:1) were always applied to help in identifying the "LPA band". The lipids in the "LPA band" were eluted with 2 ml MeOH: chloroform (2:1) twice, dried under nitrogen at 40° C. and resuspended in 100 μ L of 100% MeOH. This sample was directly used in ESI-MS (20 μ L for each injection).

Validations

ESI-MS and ESI-tandem MS (MS-MS) were performed to confirm the structures and identities of the ion peaks of interest. The method of quantitation were developed using commercially available standards. The internal standard, 17:0-LPA, was chosen due to the absence of ion species in the m/z range of 423 in blood samples, and because 17:0-LPA is not a naturally occurring LPA species.

ESI-MS Conditions

The ESI-MS and tandem mass spectrometry (MS/MS) were performed on a Micromass Quattro II Triple Quadrupole Mass Spectrometer equipped with an ESI source (Micromass Inc. Beverly, Mass.). The samples were delivered into the ESI source using a LC system (HP 1100) with an injection valve (20 μ L injection loop) via a 125 μ m PEEK tubing. The mobile phase used for all experiments was MeOH: H_2O (1:1:v:v) and the flow rate was 50 μ L/min.

The instrument settings used are as follows: the ionspray interface was maintained at 70° C. with a nitrogen nebulization flow of 10 L/h. The ESI drying gas (N_2) was at 250 L/h. For the product (79) or (184) scan modes with negative or positive detection, the argon (as collision gas) was at a pressure of 10×10^6 bar or 1×10^{-5} bar; the ionspray voltages were –3,500 V or 3,500 V; the counter electrode potentials were –500V or 500V; the sample cone potentials were –50V

or 20V; the collision energies were 70 or 50 eV; and the skimmer voltages were –1.0 or 2.0V, respectively. The product (79) scan mode with negative ion detection was used in all standard and sample analyses. Detection of LPA and other related lyso-PLs in the "LPA band" of plasma samples.

Ion species were detected in the range of m/z 400–7000. This range includes all major species of lysophospholipids, but exclude di- or tri-phosphate-1PIs (>700, which were absent in the "LPA band."

FIG. 1 show the representative mass spectra of lysophospholipids from patient with ovarian or peritoneal cancer (FIG. 1A) or healthy controls (FIG. 1B) The major ions and their identities are 409 (16:0-LPA), 433–437 (18:2, 18:1 and 18:0-LPAs, 457, 481–482, 571 (16:0-LPI), 599 (18:0-LPI) and 619 (20:4-LPI). Patients with either ovarian or peritoneal cancer had higher levels of both LPA and LPI as compared to healthy controls.

The identities of these ion species were achieved through three steps: 1) the m/z of the ion species; ii) the presence of the phosphoryl group [detected in the product (79) scan mode]; and iii) MS-MS analysis of the daughter ions of these species in negative detection mode. For 16:0-LPA, the major products were the phosphoryl group PO_3^- ion (at m/z 790), $PO_4H_2^-$ ion (at m/z 97), glycerol phosphoryl $C_3H_6O_2PO_3^-$ ion (at m/z 153), O-glycerol phosphoryl $C_3H_6O_3PO_4H_2^-$ ion (at m/z 171), palmitic acid ($C_{16}H_{31}O_2^-$, at m/z 255) (FIG. 5A). LPI (18:0) mainly showed the PO_3^- , $PO_4H_2^-$, glycerol phosphate $C_3H_6O_2PO_3^-$, phosphoinositol $C_6H_{10}O_6PO_2^-$ ion (at m/z 241), and stearic acid ($C_{18}H_{35}O_2^-$ at m/z 283) ions. LPS mainly showed the PO_3^- , $PH_2H_2^-$, glycerol phosphate $C_3H_6O_2PO_3^-$, O-glycerol phosphoryl $C_3H_6O_2PO_4H_2^-$, oleic acid ($C_{18}H_{33}O_2^-$ at m/z 281) and 18:1-LPA (loss of serine; at m/z 435). Ion species at 435, 437, 571 and 619 also showed expected daughter ions.

Optimal ionization conditions for simultaneously detecting LPAs and LPIs in blood samples were tested. While 0.5 mM NH_4OH did not affect the ionization efficiency of LPAs, it slightly reduced the ionization efficiency of LPI. Addition of 5 mM ammonium acetate reduced the ionization efficiency of LPAs to approximately 40%, but increased the ionization efficiency of LPI to approximately 30%. To balance the simultaneously detection efficiency for both LPAs and, LPIs, we chose to use MeOH without any additives.

We examined the levels of LPAs and LPIs in a series of plasma sample dilutions (0.1, 0.2, 0.4, 0.5, 0.6, 0.8 and 1 ml) and found that the detected levels of LPAs and LPIs were linear in this range, therefore 0.5 ml of plasma samples were used in our later studies.

Quantitative Analysis of LPAs and LPIs in Blood Samples

To perform quantitative analysis of levels of LPA and LPI, we established standard curves using the ratios of different amount (5–300 pmol) of a combination of standard 14:0-LPA, 16:0-LPA, 18:0-LPA, 18:1-LPA, 16:0-LPI (Sigma) and 18:0-LPI to a fixed amount (50 pmol) of the internal standard 17:0-LPA (Avanti). The areas of each ion species were obtained from the chromatogram. To determine whether different LPI species have different ionization efficiencies, we used the natural LPI isolated from soybean, which contains 62% 16:0-LPI as analyzed by Sigma using a GC-based analysis (cat. #L-7635, lot #46H8390). All LPAs and LPIs displayed linear curves in the concentration range tested. The slopes of standard curves for different LPA species were different. Surprisingly, we found that the LPA with longer fatty acid side chains had higher ionization

efficiencies, compared with shorter ones. This is reflected by their higher slopes. The slopes of 18:0-LPA and 18:1-LPA were very similar, suggesting that the double bond did not affect ionization efficiency significantly. Plotting the slopes for 14:0-LPA, 16:0-LPA and 18:0-LPA against the length of their side chains, a linear relationship was obtained. By extending this curve, we obtained the theoretical slopes for 20:4-LPA (2.12) and 22:6-LPA (2.50). These values were used in calculations for the total LPA levels. In addition, the slope (1.73) for 18:1-LPA was used for 18:2-LPA calculations. A similar trend was observed in the LPI series. Therefore a theoretical slope (1.21) was deduced for 20:4-LPI and used for the calculations.

We applied the established method to the analysis of plasma samples from 9 patients with either ovarian (8) or endometrial cancer (1) and 8 healthy female controls and two women with benign gynecological disease (uterus fibroids). Total plasma LPA, LPI and LPA+LPI levels from these subjects are shown in FIG.2. The patients group clearly showed higher levels of both LPA and LPI levels, and levels of total LPA and LPI apparently separated better between patients and control groups than either LPA or LPI alone.

Although the invention has been described with regard to a number of preferred embodiments, which constitute the best mode presently known to the inventors for carrying out this invention, it should be understood that various changes and modifications as would be obvious to one having the ordinary skill in this art may be made without departing from the scope of the invention which is defined by the claims which are appended hereto.

What is claimed:

1. A method of diagnosing ovarian carcinoma in a subject comprising: assaying for the presence of lysophosphatidyl

inositol in a bodily fluid from the subject; determining the level of lysophosphatidyl inositol in said bodily fluid to provide a test value; and comparing the test value to a standard value, wherein a test value above the standard value is indicative of ovarian carcinoma.

2. The method of claim 1 wherein said bodily fluid is blood.

3. The method of claim 1 further comprising the step of determining the level of lysophosphatidic acid in said fluid to provide a combined test value, wherein the combined test value is based on the level of lysophosphatidic acid and the level of lysophosphatidyl inositol in said bodily fluid; and comparing the combined test value to a combined standard value, wherein a combined test value above the combined standard value is indicative of ovarian carcinoma.

4. A method of diagnosing ovarian carcinoma in a subject comprising: assaying for the presence of lysophosphatidyl inositol in a plasma sample from the subject; determining the level of lysophosphatidyl inositol in said plasma sample to provide a test value; and comparing the test value to a standard value, wherein a test value above the standard value is indicative of ovarian carcinoma.

5. The method of claim 4 further comprising the step of determining the level of lysophosphatidic acid in said plasma sample to provide a combined test value, wherein the combined test value is based on the level of lysophosphatidic acid and the level of lysophosphatidyl inositol in said plasma sample; and comparing the combined test value to a combined standard value, wherein a combined test value above the combined standard value is indicative of ovarian carcinoma.

* * * * *