

**FINAL REPORT
APRIL 2003**

REPORT NO. 03-09

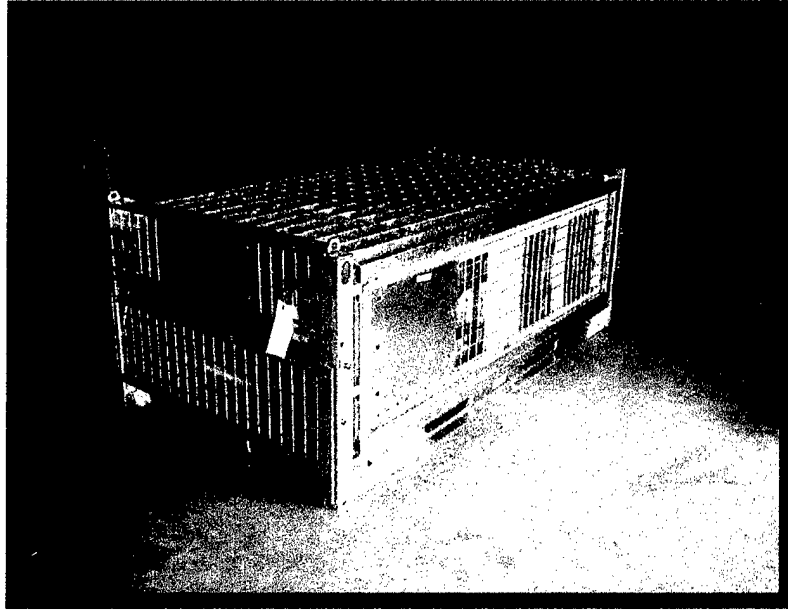

**GRATE PALLET 8232 (GP-8232) VEHICLE PALLET, EVALUATION TESTS
MIL-STD-1660, "DESIGN CRITERIA FOR AMMUNITION UNIT LOADS" &
TP-94-01 (REV 1), "TRANSPORTABILITY TESTING PROCEDURES"**

Prepared for:

Distribution Unlimited

U.S. Army Defense Ammunition Center
ATTN: SJMAC-DET
1 C Tree Road
McAlester, OK 74501-5900

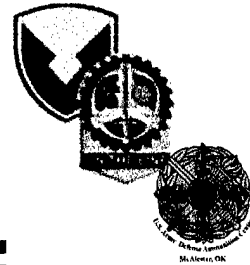

**VALIDATION ENGINEERING DIVISION
MCALESTER, OKLAHOMA 74501-9053**

DISTRIBUTION STATEMENT A:
Approved for Public Release -
Distribution Unlimited

20030523 144

AVAILABILITY NOTICE

A copy of this report will be furnished each attendee on automatic distribution. Additional copies or authority for reprinting may be obtained by written request from:

Director
U.S. Army Defense Ammunition Center
ATTN: SJMAC-DEV
1 C Tree Road, Bldg. 35
McAlester, OK 74501-9053

Reports may also be downloaded or viewed in PDF format from our web site at:

<http://www.dac.army.mil/DEV/TestReports>

DISTRIBUTION INSTRUCTIONS

Destroy this report when no longer needed. Do not return.

Citation of trade names in this report does not constitute an official endorsement.

The information contained herein will not be used for advertising purposes.

REPORT NO. 03-09

APRIL 2003

GRATE PALLET 8232 (GP-8232)

VEHICLE PALLET EVALUATION TESTS

**MIL-STD-1660, "DESIGN CRITERIA FOR AMMUNITION UNIT LOADS" &
TP-94-01 (REV 1), "TRANSPORTABILITY TESTING PROCEDURES"**

ABSTRACT

The U.S. Army Defense Ammunition Center (DAC), Validation Engineering Division (SJMAG-DEV) was tasked by the Transportation Engineering Division (SJMAG-DET) to conduct an Evaluation Test to determine if the Grate Pallet 8232 (GP-8232) Vehicle Pallet, manufactured by Grate Pallet Inc., ITN Corporation, could be utilized for the unitization and transportation of metal ammunition cans and boxed ammunition. The testing was conducted for informational purposes only. The GP-8232 Vehicle Pallet was evaluated by the testing procedures set forth in MIL-STD-1660 and TP-94-01 (Rev. 1) testing procedures. Stacking, vibration, drop, incline impact, sling compatibility, forklift handling, disassembly and on/off road transportability testing were conducted on the GP-8232 Vehicle Pallet.

The testing caused damage to the GP-8232 Vehicle Pallet. The outside tabs on the top shelves were damaged and the top shelf was no longer properly engaged. The failures created an unsafe condition, which would preclude the continued safe transport of ammunition.

Throughout the MIL-STD-1660 testing the GP-8232 Vehicle Pallet pins continuously loosened and were unable to perform as required. At the beginning of the Repetitive Shock Test one pin was ejected and one was disengaged. The disengaged pin was replaced (into position) and the other pin was replaced with a new one. Following completion of the Edgewise Drop test, two pins had to be returned to the proper position. One pin was disengaged during the Forklift Handling Test. The pins, as currently designed, are not adequately held in position.

Also, the shape of the tie-down rings on the GP-8232 Vehicle Pallet would not allow the strap hooks or keeper to properly engage.

As tested, the GP-8232 Vehicle Pallet, manufactured by Grate Pallet Inc., ITN Corporation did not successfully complete the MIL-STD-1660 and TP-94-01 test requirements.

Prepared by:

Reviewed by:

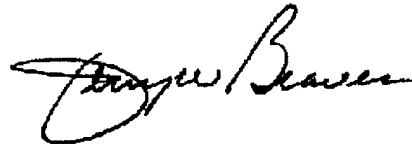
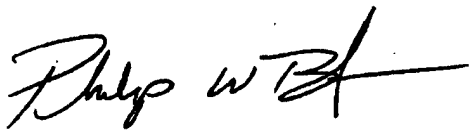

PHILIP W. BARICKMAN
Validation Engineer

JERRY W. BEAVER
Chief, Validation Engineering Division

U.S. ARMY DEFENSE AMMUNITION CENTER

**VALIDATION ENGINEERING DIVISION
MCALESTER, OK 74501-9053**

REPORT NO. 03-09

**GRATE PALLET 8232 VEHICLE PALLET EVALUATION TESTS
MIL-STD-1660, "DESIGN CRITERIA FOR AMMUNITION UNIT LOADS" &
TP-94-01 (REV 1), "TRANSPORTABILITY TESTING PROCEDURES"**

TABLE OF CONTENTS

PART	PAGE NO.
1. INTRODUCTION	1-1
A. BACKGROUND	1-1
B. AUTHORITY	1-1
C. OBJECTIVE	1-1
D. CONCLUSION	1-1
2. ATTENDEES	2-1
3. TEST PROCEDURES	3-1
4. TEST EQUIPMENT	4-1
5. TEST RESULTS	5-1
6. DRAWINGS.....	6-1

PART 1 – INTRODUCTION

A. BACKGROUND. The U.S. Army Defense Ammunition Center (DAC), Validation Engineering Division (SJMAG-DEV) was tasked by the Transportation Engineering Division (SJMAG-DET) to conduct an Engineering Evaluation Test to determine if the Grate Pallet 8232 (GP-8232) Vehicle Pallet, manufactured by Grate Pallet Inc., ITN Corporation could be utilized for the unitization and transportation of metal ammunition cans and boxed ammunition. The testing was conducted for informational purposes only. The GP-8232 Vehicle Pallet was evaluated by the testing procedures set forth in MIL-STD-1660 and TP-94-01 (Rev. 1). Stacking, vibration, drop, incline impact, sling compatibility, forklift handling, disassembly and on/off road transportability testing were conducted on the GP-8232 Vehicle Pallet. The unitization (container loading) procedures were provided by the DAC, Transportation Engineering Division (SJMAG-DET) (See Part 6).

B. AUTHORITY. This test was conducted IAW mission responsibilities delegated by the U.S. Army Joint Munitions Command (JMC), Rock Island, IL. Reference is made to the following:

1. AR 740-1, 15 June 2001, Storage and Supply Activity Operation
2. OSC-R, 10-23, Mission and Major Functions of U.S. Army Defense Ammunition Center (DAC) 21 Nov 2000.

C. OBJECTIVE. The objective of the testing was to determine if the GP-8232 Vehicle Pallet could be used as a pallet container and could successfully pass the MIL-STD-1660 and TP-94-01 test requirements. The testing was conducted for informational purposes only.

D. CONCLUSION. The testing caused damage to the GP-8232 Vehicle Pallet. During testing, the outside tabs on the top shelves were damaged and the top

shelf was no longer properly engaged. The failures created an unsafe condition, which would preclude the continued safe transport of ammunition.

Throughout the MIL-STD-1660 testing the GP-8232 Vehicle Pallet pins continuously loosened and were unable to perform as required. At the beginning of the Repetitive Shock Test one pin was ejected and one was disengaged. The disengaged pin was replaced (into position) and the other pin was replaced with a new one. Following completion of the Edgewise Drop test, two pins had to be returned to the proper position. One pin was disengaged during the Forklift Handling Test. The pins, as currently designed, are not adequately held in position.

Also, the shape of the tie-down rings on the GP-8232 Vehicle Pallet would not allow the strap hooks or keeper to properly engage.

As tested, the GP-8232 Vehicle Pallet, manufactured by Grate Pallet Inc., ITN Corporation did not successfully complete the MIL-STD-1660 and TP-94-01 test requirements.

PART 2 - ATTENDEES

ATTENDEE

MAILING ADDRESS

Philip W. Barickman
General Engineer
DSN 956-8992
(918) 420-8992

Director
U.S. Army Defense Ammunition Center
ATTN: SJMAC-DEV
1 C Tree Road, Bldg. 35
McAlester, OK 74501-9053

Jeffery L. Dugan
General Engineer
DSN 956-8090
(918) 420-8090

Director
U.S. Army Defense Ammunition Center
ATTN: SJMAC-DEV
1 C Tree Road, Bldg. 419
McAlester, OK 74501-9053

Daryl Sieczkowski
Electronics Technician
DSN 956-8988
(918) 420-8988

Director
U.S. Army Defense Ammunition Center
ATTN: SJMAC-DEV
1 C Tree Road, Bldg. 419
McAlester, OK 74501-9053

Christopher Ball
(904) 378-9944

Grate Pallet Inc.
1625 Jessie Street
Jacksonville, FL 32206

PART 3 - TEST PROCEDURES

The test procedures outlined in this section were extracted from the MIL-STD-1660 and TP-94-01 (Rev. 1). The tests are conducted on ammunition pallet units or unit loads and are summarized as follows:

A. MIL-STD-1660:

1. **STACKING TEST.** The specimen will be tested to simulate a stack of identical items stacked 16 feet high, for a period of one hour. This stacking load will be simulated by subjecting the specimen to a compression weight equal to an equivalent 16-foot stacking height. Photo 1 below shows an example of a unit load in the compression tester.

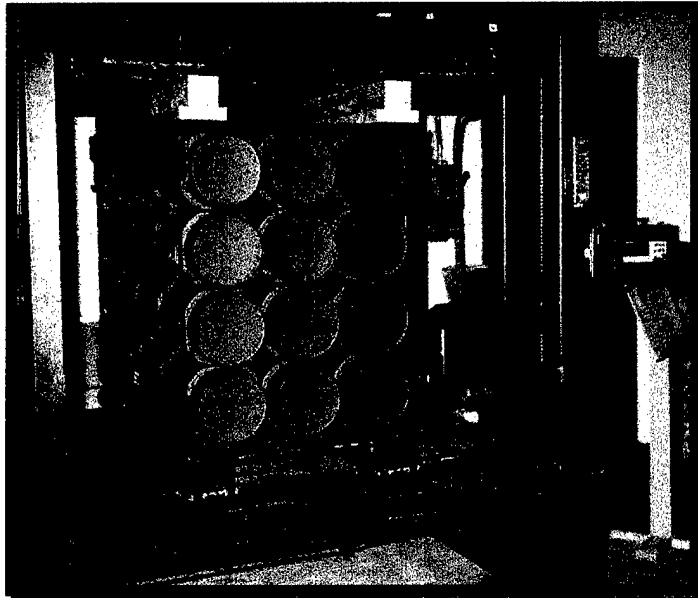

**Photo 1. Example of Compression Tester.
(2.75-inch Hydra 70, PA151 Rocket Pallet in the compression tester.)**

2. REPETITIVE SHOCK TEST. The repetitive shock test is conducted IAW Method 5019, Federal Standard 101. The test procedure is as follows: The test specimen will be placed on (not fastened to) the platform. With the specimen in one position, the platform will be vibrated at ½-inch amplitude (1-inch double amplitude) starting at a frequency of approximately 3 cycles-per-second. The frequency will be steadily increased until the specimen leaves the platform. The resonant frequency is achieved when a 1/16-inch-thick feeler gage momentarily slides freely between every point on the specimen in contact with the platform at some instance during the cycle. Midway into the testing period, the specimen will be rotated 90 degrees, and the test continued for the duration. Unless failure occurs, the total time of vibration will be three hours. Photo 2 shows an example of the repetitive shock test.

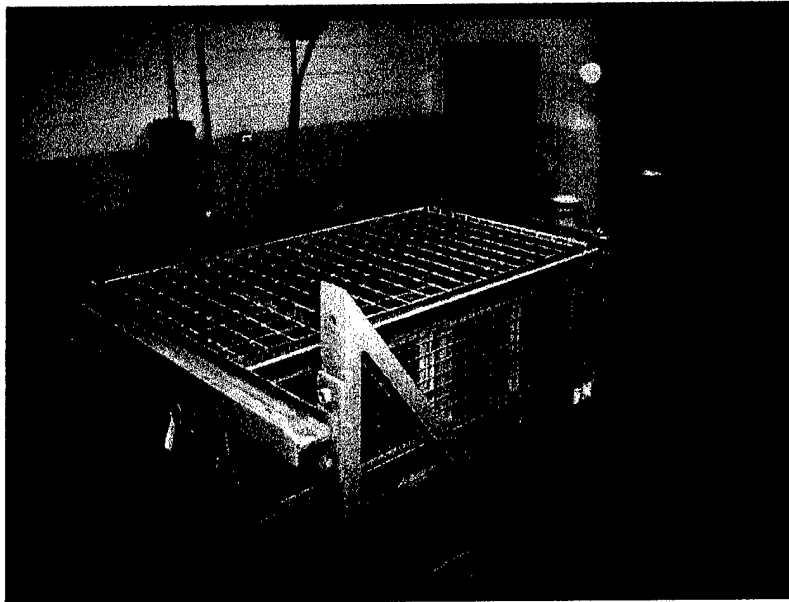

**Photo 2. Example of the Repetitive Shock Test.
(GP-8232 Vehicle Pallet)**

3. EDGEWISE ROTATIONAL DROP TEST. This test is conducted using the procedures of Method 5008, Federal Standard 101. The procedure for the edgewise rotational drop test is as follows: The specimen will be placed on its skids with one end of the pallet supported on a beam 6 inches high. The height

of the beam will be increased as necessary to ensure that there is no support for the skids between the ends of the specimen when the dropping takes place, but should not be high enough to cause the specimen to slide on the supports when the dropped end is raised for the drop. The unsupported end of the specimen is then raised and allowed to fall freely to the concrete, pavement, or similar unyielding surface from a prescribed height. Unless otherwise specified, the height of drop for level A protection will conform to the following tabulation:

GROSS WEIGHT (WITHIN RANGE LIMITS) (Pounds)	DIMENSIONS OF ANY EDGE, HEIGHT OR WIDTH (WITHIN RANGE LIMITS) (Inches)	HEIGHT OF DROPS ON EDGES	
		Level A (Inches)	Level B (Inches)
150-250	60-66	36	27
250-400	66-72	32	24
400-600	72-80	28	21
600-1,000	80-95	24	18
1,000-1,500	95-114	20	16
1,500-2,000	114-144	17	14
2,000-3,000	Above 145- No limited	15	12
Above – 3,000		12	9

Figure 1.

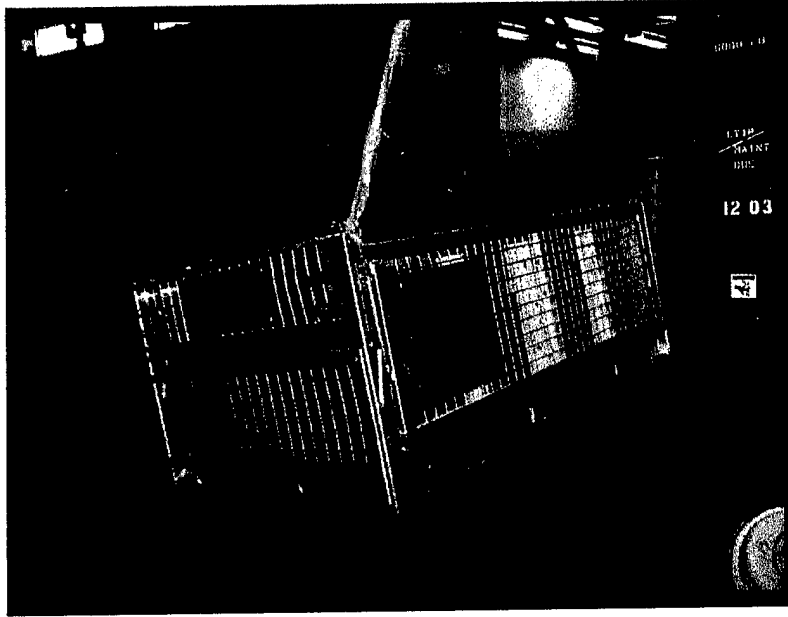

**Photo 3. Example of Edgewise Rotational Drop Test
(GP-8232 Vehicle Pallet)**

4. INCLINE-IMPACT TEST. This test is conducted by using the procedure of Method 5023, Incline-Impact Test of Federal Standard 101. The procedure for the incline-impact test is as follows: The specimen will be placed on the carriage with the surface or edge to be impacted projecting at least 2 inches beyond the front end of the carriage. The carriage will be brought to a predetermined position on the incline and released. If it were desired to concentrate the impact on any particular position on the container, a 4- x 4-inch timber may be attached to the bumper in the desired position before the test. The carriage will not strike any part of the timber. The position of the specimen on the carriage and the sequence in which surfaces and edges are subjected to impacts may be at the option of the testing activity and dependent upon the objective of the test. When the test is to determine satisfactory requirements for a container or pack, and, unless otherwise specified, the specimen will be subjected to one impact on each surface that has each dimension less than 9.5 feet. Unless otherwise specified, the velocity at the time of the impact will be 7 feet-per-second. Photo 4 shows an example of this test.

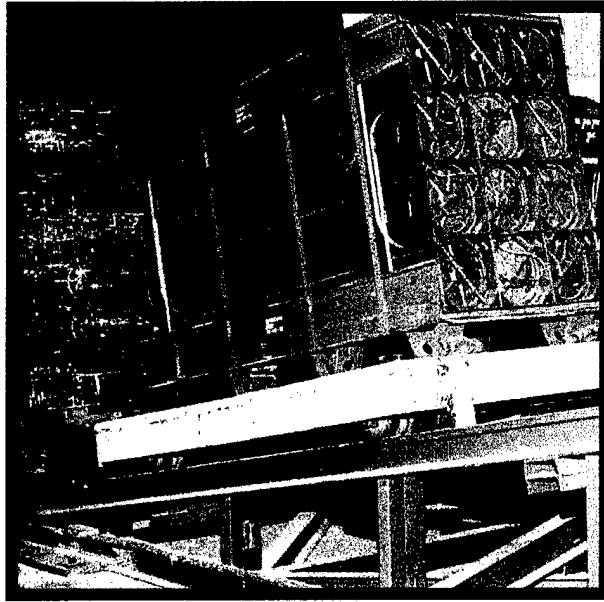

**Photo 4. Example of the Incline-Impact Test.
(2.75-Inch, Hydra 70, PA151 Rocket Pallet on incline-impact tester.)**

5. SLING COMPATIBILITY TEST. The specimen utilizing special design or non-standard pallets will be lifted, swung, lowered and otherwise handled as necessary, using slings of the types normally used for handling the unit loads under consideration. Slings will be easily attached and removed. Danger of slippage or disengagement when load is suspended will be cause for rejection of the specimen.

6. FORKLIFTING TESTS. The specimen will be lifted clear of the ground by a forklift from the end of the specimen and transported on the forks in the level or back-tilt position across a hard pavement for a distance of not less than 100 feet. The forklift will also pass over the forklift hazard course as outlined in MIL-STD-1660. The hazard course will consist of parallel pairs of 1-inch boards spaced 54 inches apart and will be laid flat wise on the pavement across the path of the forklift. The first pair will be placed securely across the forklift's path and centered 30 feet from the starting point; the second pair will be laid 60 feet from the starting point at an angle of approximately 60 degrees to the path so the first wheel strikes first; and the third pair will be laid 90 feet from the starting point

approximately 75 degrees to the path so the right wheel strikes first. The forklift will pass over the forklift hazard course 3 times in approximately 23 seconds, and then be brought to a stop. The load shall be observed for deflection and damage. The specimen will be rotated 90 degrees and the load lifted from the side and the above steps repeated.

B. ON/OFF ROAD TESTS.

1. **HAZARD COURSE.** The test load or vehicle will be transported over the 200-foot-long segment of concrete-paved road consisting of two series of railroad ties projecting 6 inches above the level of the road surface. The hazard course will be traversed two times (see Figure 2).

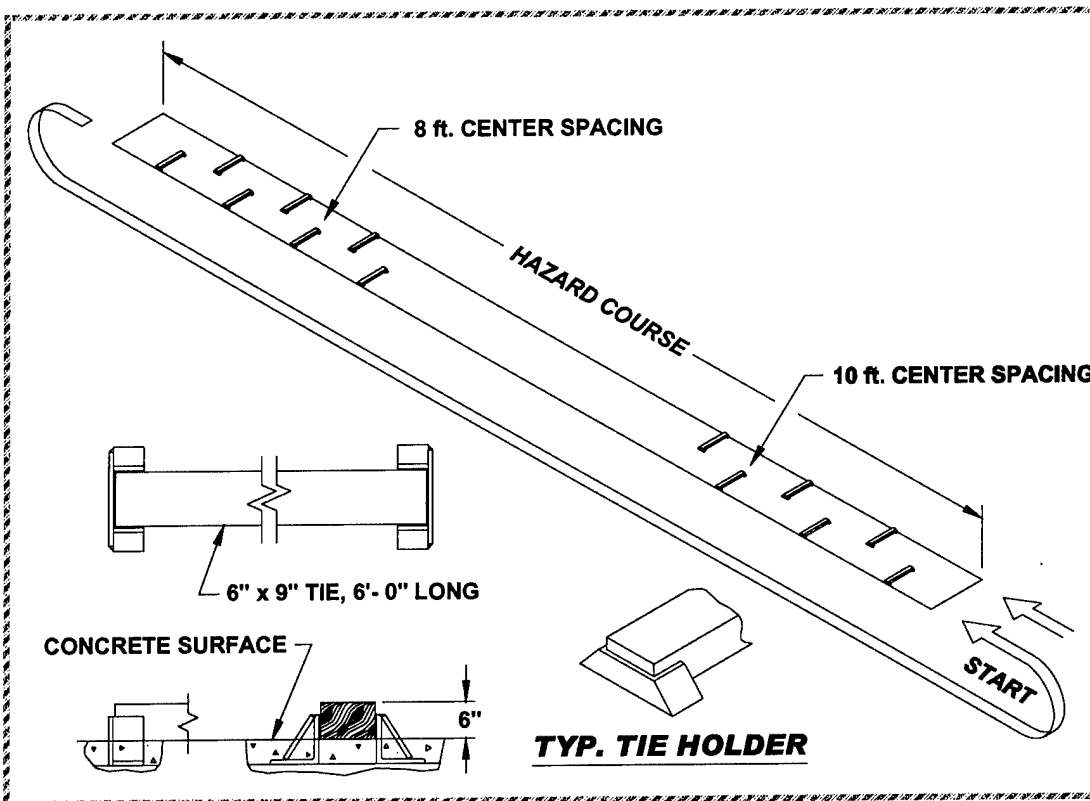

Figure 2. Hazard Course Sketch

- a. The first series of ties are spaced on 10-foot centers and alternately positioned on opposite sides of the road centerline for a distance of 50 feet.
- b. Following the first series of ties, a paved roadway of 75 feet separates the first and second series of railroad ties.
- c. The second series of ties are spaced on 8-foot centers and alternately positioned on opposite sides of the road centerline for a distance of 50 feet.
- d. The test load is driven across the hazard course at speeds that will produce the most violent vertical and side-to-side rolling reaction obtainable in traversing the hazard course (approximately 5 mph).

2. **ROAD TRIP**. The test load or vehicle will be transported for a distance of 30 miles over a combination of roads surfaced with gravel, concrete, and asphalt. The test route will include curves, corners, railroad crossings and stops and starts. The test load or vehicle will travel at the maximum speed for the particular road being traversed, except as limited by legal restrictions.

3. **PANIC STOPS**. During the road trip, the test load or vehicle will be subjected to three (3) full airbrake stops while traveling in the forward direction and one in the reverse direction while traveling down an approximate 7 percent grade. The first three stops are at 5, 10, and 15 mph while the stop in the reverse direction is approximately 5 mph. This testing will not be required if the Rail Impact Test is performed.

4. **HAZARD COURSE**. The test load or vehicle will be transported over the 200-foot-long segment of concrete-paved road consisting of two series of railroad ties projecting 6 inches above the level of the road surface. The hazard course will be traversed an additional two times (see Figure 2).

- a. The first series of ties are spaced on 10-foot centers and alternately positioned on opposite sides of the road centerline for a distance of 50 feet.
- b. Following the first series of ties, a paved roadway of 75 feet separates the first and second series of railroad ties.

c. The second series of ties are spaced on 8-foot centers and alternately positioned on opposite sides of the road centerline for a distance of 50 feet.

d. The test load is driven across the hazard course at speeds that will produce the most violent vertical and side-to-side rolling reaction obtainable in traversing the hazard course (approximately 5 mph).

5. **WASHBOARD COURSE.** The test load or vehicle will be driven over the washboard course at a speed that produces the most violent response in the vertical direction.

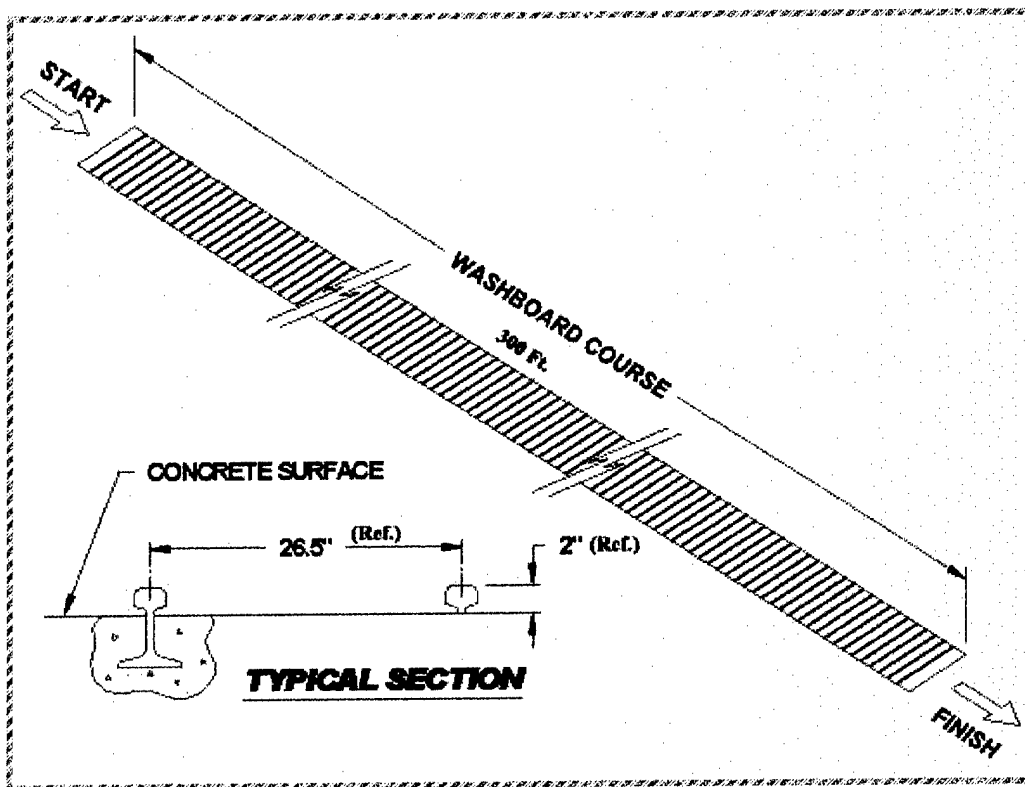

Figure 3. Washboard Course Sketch

C. **DISASSEMBLY TEST.** Following all rough handling tests the specimen may be squared up within 2 inches of its original shape and on a flat level surface. The strapping will then be cut and removed from the palletized load. Assembly of the specimen will be such that it retains its unity upon removal of the strapping.

PART 4 - TEST EQUIPMENT

A. COMPRESSION TESTER.

- | | |
|-----------------------|----------------------|
| 1. Manufacturer: | Ormond Manufacturing |
| 2. Platform: | 60- x 60-inches |
| 3. Compression Limit: | 50,000 pounds |
| 4. Tension Limit: | 50,000 pounds |

B. TRANSPORTATION SIMULATOR.

- | | |
|------------------|---------------------|
| 1. Manufacturer: | Gaynes Laboratory |
| 2. Capacity: | 6,000-pound payload |
| 3. Displacement: | 1/2-inch amplitude |
| 4. Speed: | 50 to 400 RPM |
| 5. Platform: | 5- x 8-foot |

C. INCLINED PLANE.

- | | |
|------------------|--------------------|
| 1. Manufacturer: | Conbur Incline |
| 2. Type: | Impact Tester |
| 3. Grade: | 10 percent incline |
| 4. Length: | 12-foot |

D. TRUCK UTILITY: CARGO/TROOP CARRIER, 1.25 TON, 4X4.

High Mobility Multipurpose Wheeled Vehicle (HMMWV)

Model: M998

Manufacturer: A.M. General Corporation

Mfg Serial Number: 004343

Registration Number: NG23EK

Date of Delivery: 09/85

PART 5 - TEST RESULTS

A. PALLET DATA. Each pallet container was inertly loaded to the specified design weight using inert simulation in wooden boxes. The test specimen was prepared using the unitization procedures specified in Part 6 – Drawings. Special care was taken to ensure that each C445 wooden box had the proper amount of weight in order to achieve a realistic pallet center of gravity (CG). Once properly prepared, the vehicle pallet was tested using MIL-STD-1660 and TP-94-01 (Rev. 1) requirements.

GRATE PALLET 8232 (GP-8232) VEHICLE PALLET

Date: 25 February – 3 March 2003
Gross Weight: 2345 pounds
Length: 82 1/4 inches
Width: 45 1/2 inches
Height: 32 inches
Mfg: Grate Pallet Inc., ITN Corporation

B. GRATE PALLET 8232 (GP-8232) VEHICLE PALLET- TEST RESULTS:

1. COMPRESSION TEST. The test specimen was compressed with a load force of 12,230 pounds for 60 minutes on 25 February 2003. No damage was noted as a result of this test. See Photo 5 of the test specimen in the compression unit.

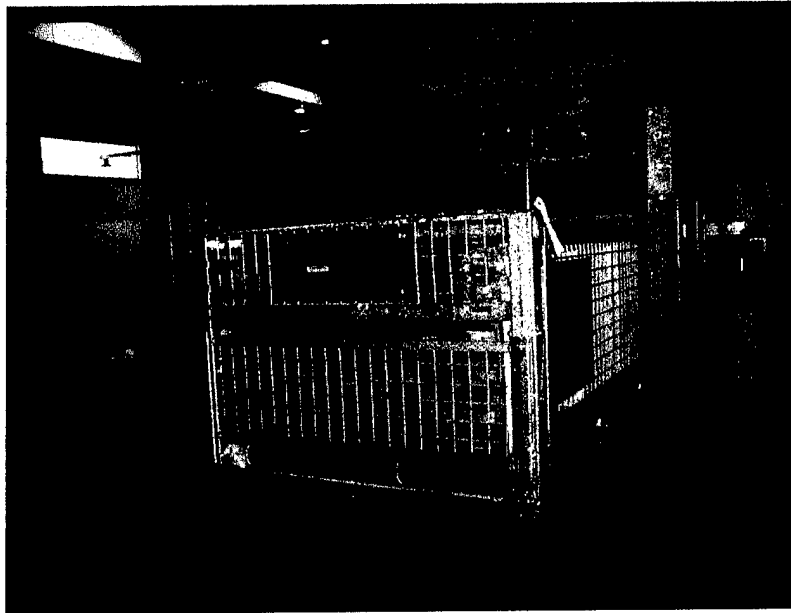

Photo 5. GP-8232 Vehicle Pallet in the Compression Tester.

2. REPETITIVE SHOCK TEST. The specimen was vibrated 90 minutes at 232 RPM in the longitudinal orientation and 90 minutes at 231 RPM in the lateral orientation. Photo 6 shows the GP-8232 Vehicle Pallet on the vibration platform. Photo 7 shows the top shelf, hook slider that was damaged and dislodged during testing. At the beginning of the repetitive shock test the wire ties holding each of the top shelf, hook sliders were damaged.

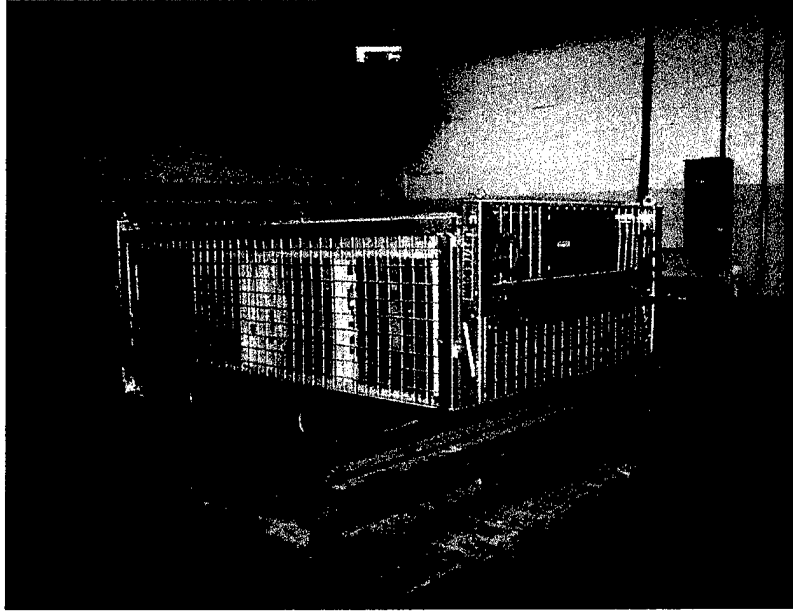

Photo 6. GP-8232 Vehicle Pallet During Repetitive Shock Testing.

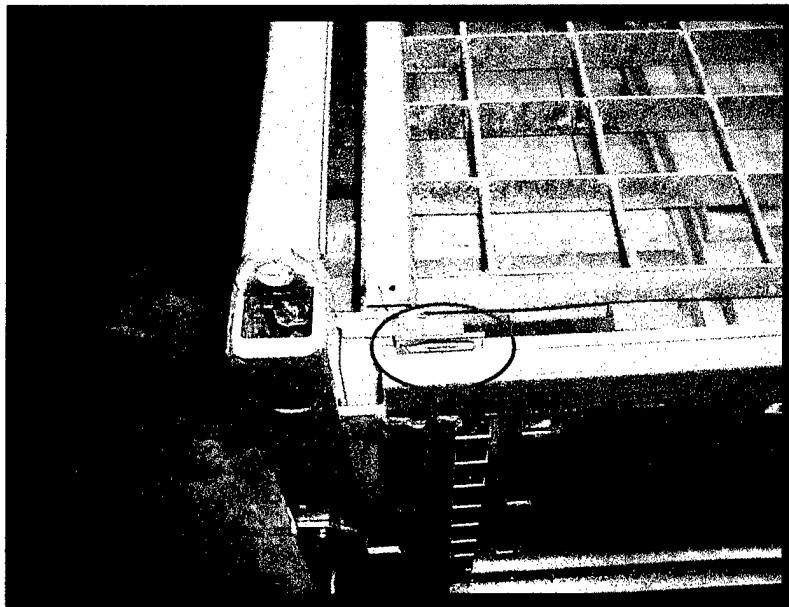

Photo 7. Damaged and Dislodged Top Shelf, Hook Slider.

3. EDGEWISE ROTATIONAL DROP TEST. The specimen was edgewise rotationally dropped from a height of 15 inches on both longitudinal sides and both lateral sides. Photo 8 shows the GP-8232 Vehicle Pallet during the drop test. During the drop testing the two hooks on the top shelf were damaged and

the top shelf disengaged and misaligned. The GP-8232 Vehicle Pallet did not retain adequate integrity and was no longer safe to handle. The MIL-STD 1660 testing was continued for informational purposes only. The damage to the top shelf hooks allowed accessibility to the payload without disassembly. Photo 9 shows the top shelf disengagement. Also, the remaining top shelf, hook slider was damaged and became detached from the frame.

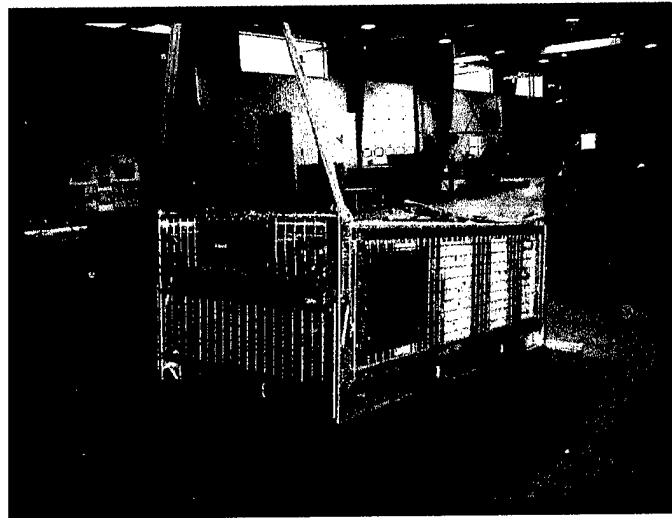

Photo 8. Drop Test on the GP-8232 Vehicle Pallet.

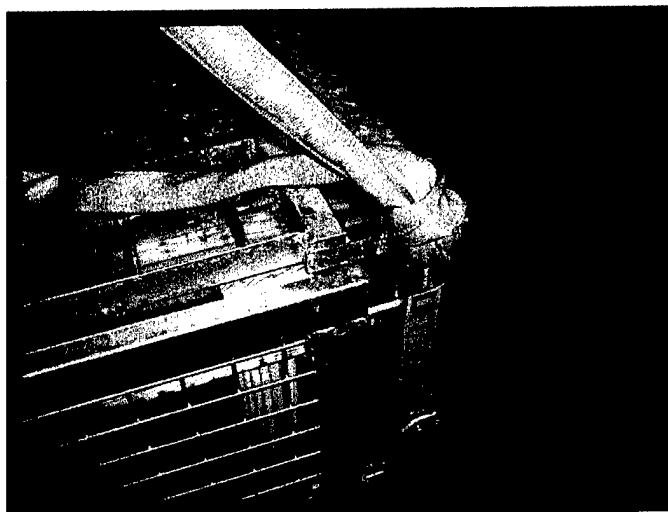

Photo 9. Disengagement of Top Shelf.

4. **INCLINE-IMPACT TEST.** The GP-8232 was impact tested on both longitudinal sides and both lateral sides. See Photo 10 for the GP-8232 Vehicle Pallet during the lateral incline-impact test. During the incline-impact testing the hooks on the top shelf disengaged at all four corners and misaligned. Photo 11 shows one of the disengaged top shelf hooks.

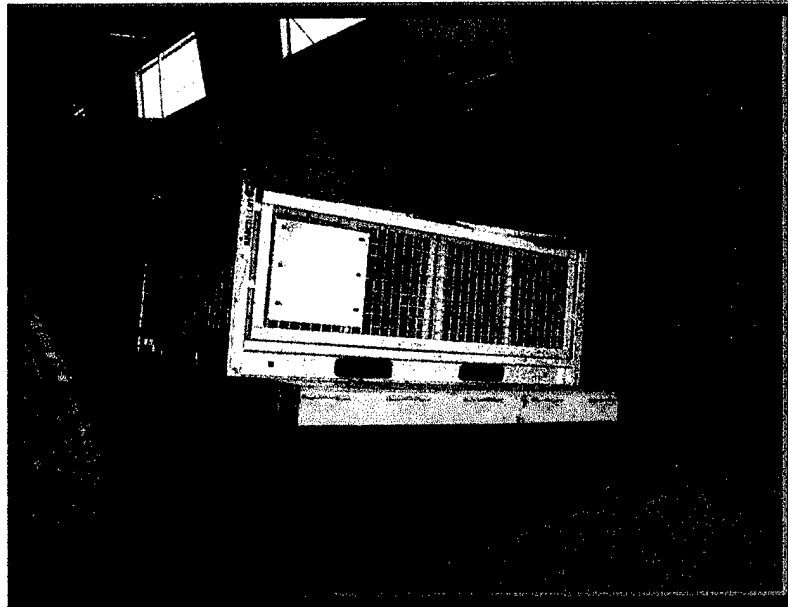

Photo 10. Incline-Impact Testing of the GP-8232 Vehicle Pallet

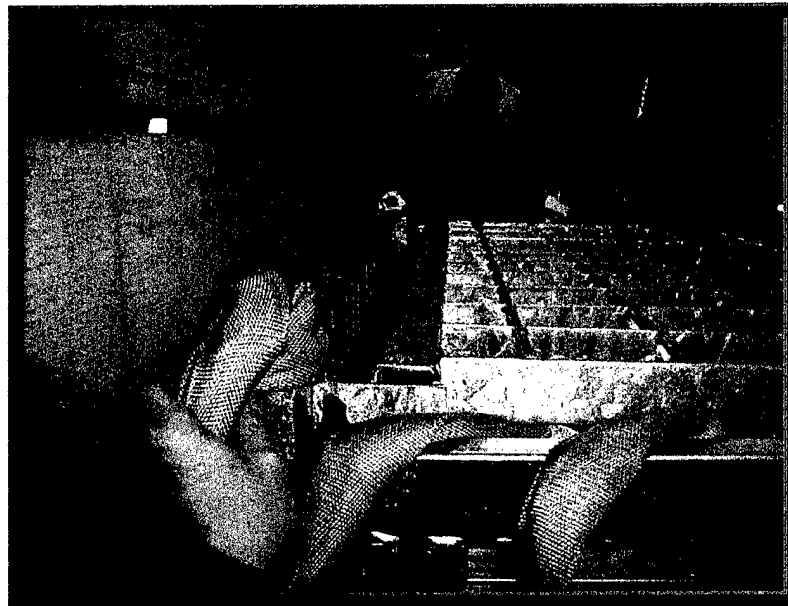

Photo 11. Disengaged Top Shelf Hook

5. SLING COMPATIBILITY TEST. During testing the GP-8232 Vehicle Pallet was lifted, swung, lowered and handled as necessary using slings of the types normally used for handling the unit loads. The compatibility testing was conducted using a two-point lift, a three-point lift and a four-point lift. During the testing the pallet had extensive racking, causing the top shelf to become dislodged and misaligned. The slings were easily attached and removed. Photo 12 shows the GP-8232 Vehicle Pallet during the three-point lift test.

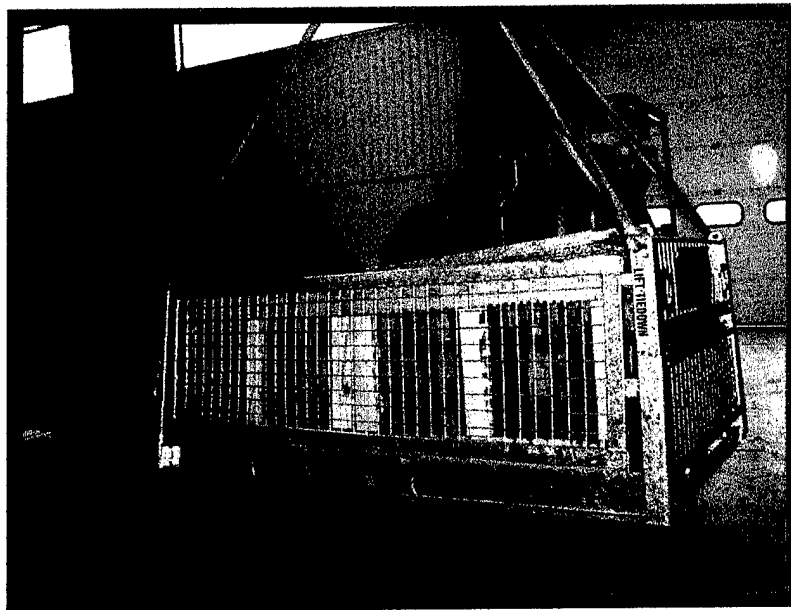

Photo 12. Sling Compatibility Testing and Top Shelf Misalignment.

6. FORKLIFTING TEST. The GP-8232 Vehicle Pallet was lifted clear of the ground by a forklift from both longitudinal sides and both lateral sides and transported on the forks. Photo 13 shows the GP-8232 Vehicle Pallet during the Forklift Test. During the final pass the top shelf dislodged and misaligned.

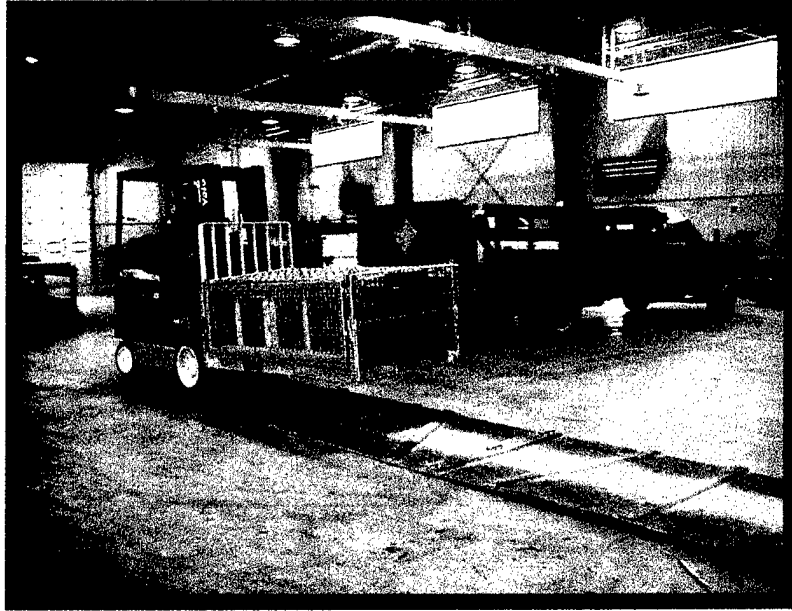

Photo 13. GP-8232 Vehicle Pallet During the Forklift Test

C. TRANSPORTABILITY TESTING. Following completion of the MIL-STD-1660 testing a second GP-8232 Vehicle Pallet was loaded for the Transportability Testing and secured in the High Mobility Multipurpose Wheeled Vehicle (HMMWV). Photo 14 shows the GP-8232 Vehicle Pallet secured in the HMMWV. The shape of the tie-downs on the GP-8232 Vehicle Pallet would not allow the strap hooks or keepers to properly engage.



Photo 14. GP-8232 Secured in the HMMWV

1. ON/OFF ROAD TESTS.

a. HAZARD COURSE.

Pass No.	Elapsed Time	Avg. Velocity (MPH)
1	20 Seconds	6.4
2	20 Seconds	6.4

Figure 4.

Remarks:

- a. Figure 4 lists the average speeds of the test load through the Hazard Course Passes 1 and 2.
- b. No damage occurred. The GP-8232 Vehicle Pallet maintained adequate integrity and safe handling capability and testing was continued. Photo 15 shows the GP-8232 Vehicle Pallet during transport over the Hazard Course.



Photo 15. GP-8232 Vehicle Pallet During Hazard Course Transport

b. ROAD TRIP: No damage occurred. The GP-8232 Vehicle Pallet maintained adequate integrity and safe handling capability and testing was continued.

c. PANIC STOPS: No damage occurred. The GP-8232 Vehicle Pallet maintained adequate integrity and safe handling capability and testing was continued.

d. HAZARD COURSE:

Pass No.	Elapsed Time	Avg. Velocity (MPH)
3	20 Seconds	6.4
4	18 Seconds	7.1

Figure 5.

Remarks:

a. Figure 5 lists the average speeds of the test load through the Hazard Course Passes 3 and 4.

b. No additional damage occurred. The GP-8232 Vehicle Pallet maintained adequate integrity and safe handling capability and testing was continued.

e. **WASHBOARD COURSE:** No additional damage occurred. The GP-8232 Vehicle Pallet maintained adequate integrity and safe handling capability and testing was continued. Photo 16 shows the GP-8232 Vehicle Pallet during transport over the Washboard Course.



Photo 16. GP-8232 Vehicle Pallet During Washboard Testing

7. **DISASSEMBLY TEST.** During the disassembly of the GP-8232 Vehicle Pallet no additional damage was discovered. The GP-8232 Vehicle Pallet maintained adequate integrity and was still considered safe to handle.

8. **CONCLUSION.** The testing caused damage to the GP-8232 Vehicle Pallet. During testing, the outside tabs on the top shelves were damaged and the top shelf was no longer properly engaged. The failures created an unsafe condition, which would preclude the continued safe transport of ammunition.

Throughout the MIL-STD-1660 testing the pins continuously loosened and were unable to perform as required. At the beginning of the Repetitive Shock Test on

pin was ejected and one was disengaged. The disengaged pin was replaced (into position) and the other pin was replaced with a new one. Following completion of the Edgewise Drop test two pins had to be returned to the proper position. One pin was disengaged during the Forklift Handling Test. The pins, as currently designed, are not adequately held in position.

The shape of the tie-down rings on the GP-8232 Vehicle Pallet would not allow the strap hooks or keeper to properly engage.

As tested, the GP-8232 Vehicle Pallet, manufactured by Grate Pallet Inc., ITN Corporation did not successfully complete MIL-STD-1660, "Design Criteria for Ammunition Unit Loads" testing requirements.

PART 6 – DRAWING

MIL-STD-1660 TESTING OF THE GRATE PALLET 8232 - VEHICLE PALLET

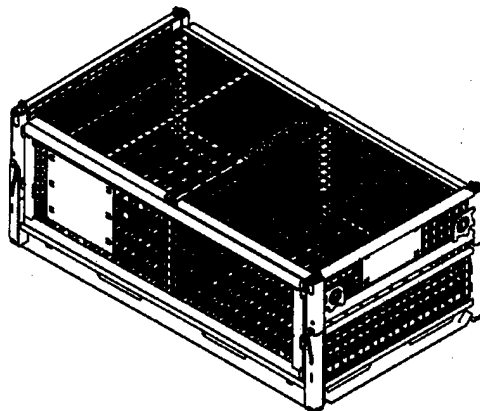

THIS TWO PAGE DOCUMENT DEPICTS PROCEDURES FOR UNITIZING
THE TEST LOAD FOR THE GP8232 MIL-STD 1660 TESTING.

OVERALL DIMENSIONS OF THE GP8232:
82-3/8" L X 45-3/8" W X 31-3/4" H

Prepared during January 2003 by:
U.S. Army Defense Ammunition Center
ATTN: SJMAC-DET
McAlister, OK 74501
POC: Mike Bartosiak
DSN 956-3083
Comm (918) 420-8083
Fax 956-8811
E-mail: michael.bartosiak@dac.army.mil

Laura Fieffer
Acting Chief, Transportation Engineering Division

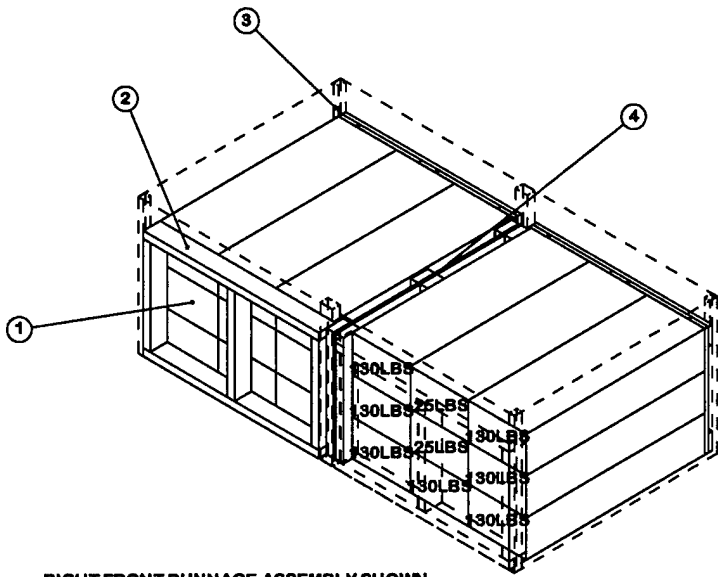

RIGHT FRONT DUNNAGE ASSEMBLY SHOWN AS HIDDEN LINES TO SHOW WEIGHT OF INERT TEST LOAD. THESE WEIGHTS WILL BE USED BOTH THE LEFT AND RIGHT SET OF INERT 105MM WOODEN BOXES.

● INTERIOR DIMENSIONS OF THE GP8232 SHOWN BY DASHED OUTLINE.
 INTERNAL DIMENSIONS BETWEEN WIRE MESH PANELS: 78-3/4" L X 42-3/8" W X 22-7/8" H
 EXTERNAL DIMENSIONS OF GP8232: 82-3/8" L X 45-3/8" W X 31-3/4" H

TEST SKETCH DETAILS

- ① 37-1/4" L X 12" W X 7-1/2" H, 105MM WOOD BOXES, WEIGHTED AS SHOWN ABOVE, LOADED AS SHOWN ABOVE, 18 REQUIRED.
- ② FRONT ASSEMBLY, SEE DETAIL BELOW, 2 REQUIRED.
- ③ REAR ASSEMBLY, SEE DETAIL BELOW, 2 REQUIRED.
- ④ CENTER ASSEMBLY, SEE DETAIL BELOW, 1 REQUIRED.

GP8232 UNIT LOAD

18 BOXES OF 105MM HOWITZER AT (VARY) -----	1,920 LBS (APPROX)
DUNNAGE -----	62 LBS (APPROX)
GP8232 -----	??? LBS
TOTAL WEIGHT -----	?, ??? LBS (APPROX)
CUBE -----	68.7 CU FT (APPROX)

BILL OF MATERIAL		
LUMBER	LINEAR FEET	BOARD FEET
1" X 4"	23.50	7.84
2" X 4"	33.25	22.17
NAILS		POUNDS
2d (1")	24	.03
10d (3")	48	.73
GP8232 -----	1 REQD -----	??? LBS
PLYWOOD, 1/2" -----	6.05 SQ FT REQD -----	8.33 LBS

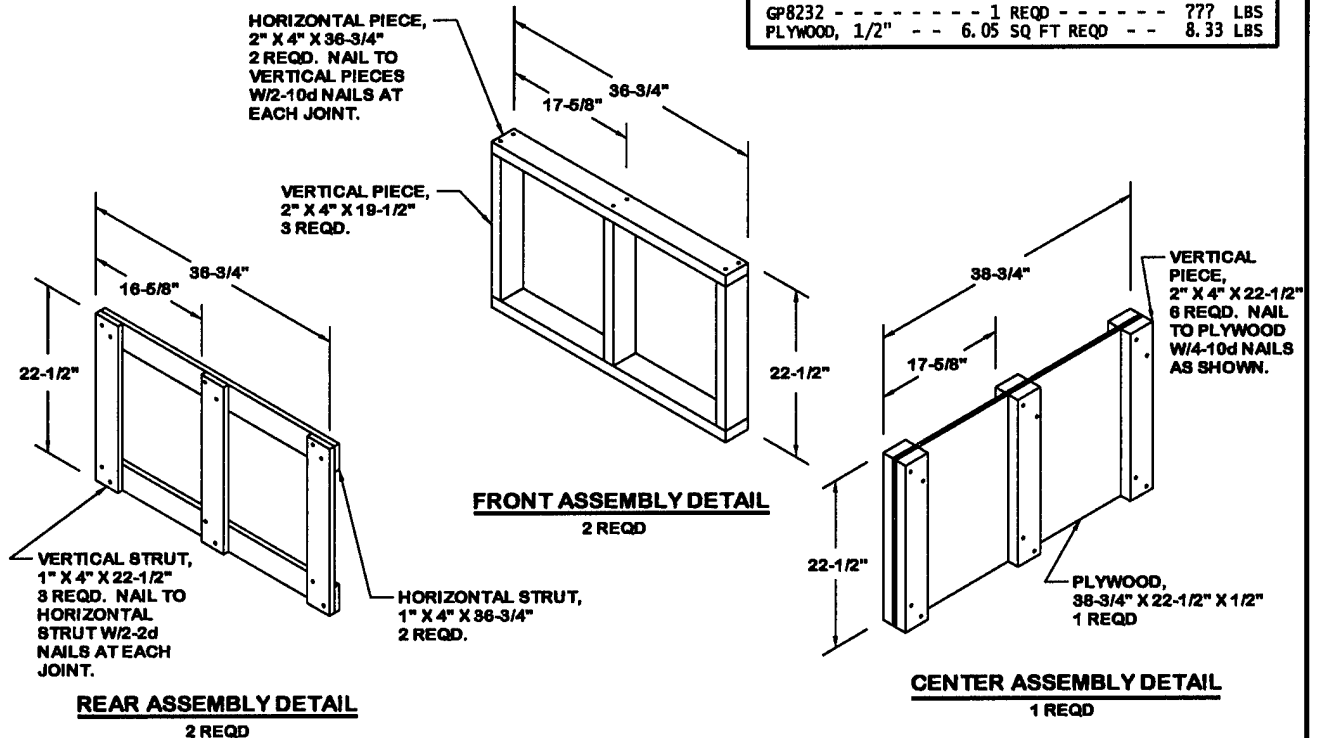

TRANSPORTABILITY TESTING OF THE GRATE PALLET 8232 - VEHICLE PALLET (ROAD HAZARD COURSE)

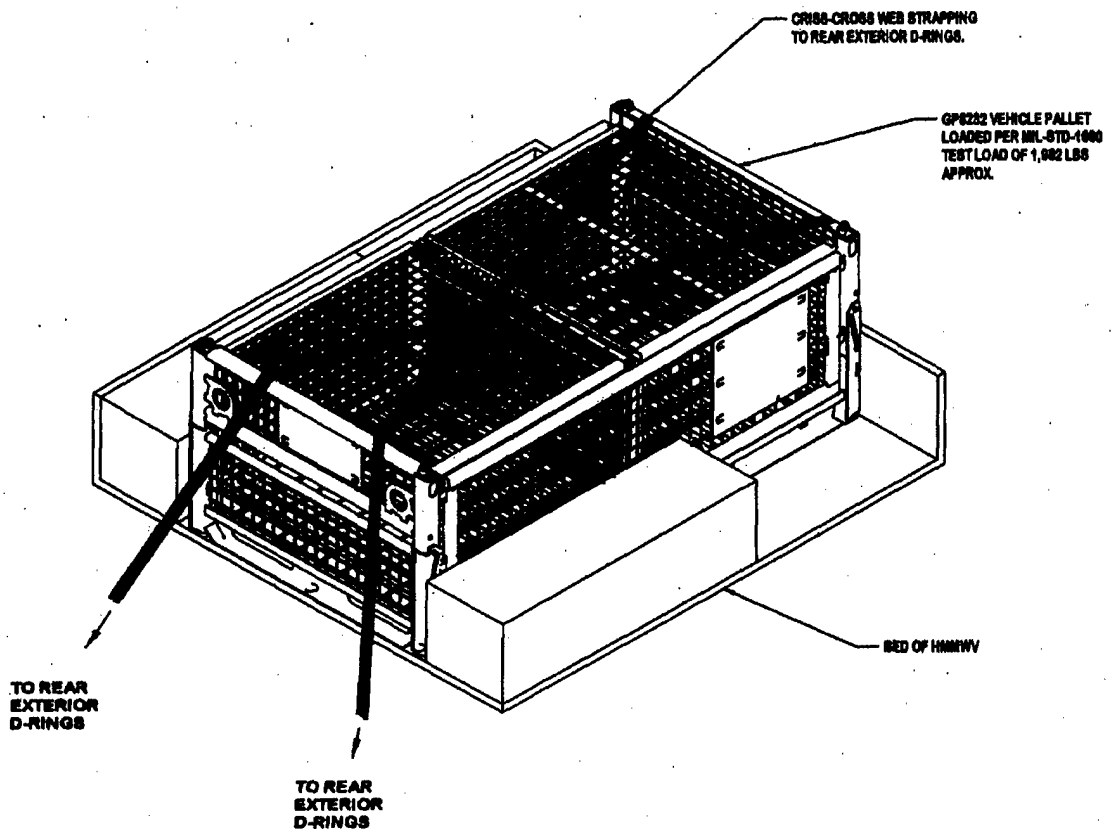

THIS ONE PAGE DOCUMENT DEPICTS PROCEDURES FOR UNITIZING
THE TEST LOAD FOR THE GP8232 INTO A HMMWV.

OVERALL DIMENSIONS OF THE GP8232:
82-3/8"L X 46-3/8"W X 31-3/4"H

Prepared during January 2003 by:
U.S. Army Defense Ammunition Center
ATTN: SOSAC-DET
McAlester, OK 74501
POC: Mike Bartosiak
DSN 958-8083
Comm (918) 420-8083
Fax 958-8811
E-mail: michael.bartosiak@dac.army.mil

Laura Fieffer
Laura Fieffer

Acting Chief, Transportation Engineering Division