

# REPORT DOCUMENTATION PAGE

Form Approved  
OMB No. 0704-0188

Public reporting burden for this collection of information is estimated to average 1 hour per response, including the time for reviewing instructions, searching existing data sources, gathering and maintaining the data needed, and completing and reviewing this collection of information. Send comments regarding this burden estimate or any other aspect of this collection of information, including suggestions for reducing this burden to Department of Defense, Washington Headquarters Services, Directorate for Information Operations and Reports (0704-0188), 1215 Jefferson Davis Highway, Suite 1204, Arlington, VA 22202-4302. Respondents should be aware that notwithstanding any other provision of law, no person shall be subject to any penalty for failing to comply with a collection of information if it does not display a currently valid OMB control number. **PLEASE DO NOT RETURN YOUR FORM TO THE ABOVE ADDRESS.**

1. REPORT DATE (DD-MM-YYYY) 24 April 2003		2. REPORT TYPE Technical Paper		3. DATES COVERED (From - To)	
4. TITLE AND SUBTITLE  In-Space Propulsion				5a. CONTRACT NUMBER	
				5b. GRANT NUMBER	
				5c. PROGRAM ELEMENT NUMBER	
6. AUTHOR(S)  Frank Gulczinski III, Ronald A. Spores, Johannes Stuhlberger				5d. PROJECT NUMBER 6340	
				5e. TASK NUMBER 0039	
				5f. WORK UNIT NUMBER	
7. PERFORMING ORGANIZATION NAME(S) AND ADDRESS(ES)  Air Force Research Laboratory (AFMC) AFRL/PRSS 1 Ara Drive Edwards AFB CA 93524-7013				8. PERFORMING ORGANIZATION REPORT NUMBER  AFRL-PR-ED-TP-2003-105	
9. SPONSORING / MONITORING AGENCY NAME(S) AND ADDRESS(ES)  Air Force Research Laboratory (AFMC) AFRL/PRS 5 Pollux Drive Edwards AFB CA 93524-7048				10. SPONSOR/MONITOR'S ACRONYM(S)	
				11. SPONSOR/MONITOR'S NUMBER(S) AFRL-PR-ED-TP-2003-105	
12. DISTRIBUTION / AVAILABILITY STATEMENT  Approved for public release; distribution unlimited.					
13. SUPPLEMENTARY NOTES					
14. ABSTRACT					
<div style="border: 1px solid black; padding: 5px; display: inline-block;"> <p style="font-size: 2em; margin: 0;">20030612 152</p> </div>					
15. SUBJECT TERMS					
16. SECURITY CLASSIFICATION OF:			17. LIMITATION OF ABSTRACT	18. NUMBER OF PAGES	19a. NAME OF RESPONSIBLE PERSON
a. REPORT	b. ABSTRACT	c. THIS PAGE	A		Sheila Benner
Unclassified	Unclassified	Unclassified			19b. TELEPHONE NUMBER (include area code) (661) 275-5693

MEMORANDUM FOR PRS (In-House Publication)

25 Apr 2003

FROM: PROI (STINFO)

SUBJECT: Authorization for Release of Technical Information, Control Number: **AFRL-PR-ED-TP-2003-105**  
Frank S. Gulczinski III and Ronald A. Spores (AFRL/PRSS); Johannes Stuhlberger (Astrium Space  
Infrastructure, Lampoldshausen, Germany), "In-Space Propulsion"

**AIAA/ICAS International Air & Space Symposium and Exposition**  
**(Dayton, OH, 14-17 Jul 2003) (Deadline: 15 Apr 2003 - PAST DUE)**

(Statement A)

---

European contributions from J. Stuhlberger are highlighted in yellow

## In-Space Propulsion

Frank S. Gulczinski III and Ronald A. Spores  
Air Force Research Laboratory, Propulsion Directorate  
Edwards AFB, California

Johannes Stuhlberger  
Astrium GmbH Space Infrastructure  
Lampoldshausen, Germany

### ABSTRACT

As the world of flight enters its second century, in-space propulsion nears the end of its first 50 years. The field is progressing rapidly, with a diversification of propulsion technologies that enable space missions that were previously untenable. This paper will summarize the state of the art and current development efforts for the major classes of spacecraft propulsion: chemical, electric, and solar thermal. Chemical propulsion systems remain the backbone of spacecraft architectures. Work continues to improve the performance, storability, and environmental friendliness of liquid monopropellant, bipropellant, cold gas, and gel systems for orbital insertion, stationkeeping, orbital maneuvering, and attitude control. Electric propulsion, once the "technology of tomorrow" has entered the mainstream of in-space propulsion, establishing operability for stationkeeping and orbital insertion and being baselined for next generation scientific deep space and interferometry missions. Research efforts are now concentrated primarily on expanding the applicable power range for electric propulsion systems in order to enable large orbit transfer vehicle applications and micro/nano spacecraft propulsion systems. Solar thermal propulsion is also discussed. A comprehensive research and development effort is ongoing in the United States and Europe in industrial, academic, and national laboratory settings to advance the state of the art for spacecraft propulsion systems. Apart from technological developments in these various fields, the economic pressure on both commercial and scientific missions is increasing and customers require an industrialization of space businesses. Improvements in these areas have been achieved within the Astrium EUROSTAR and Alcatel SPACEBUS series.

### INTRODUCTION

Since the earliest days of the Space Age, the need to maneuver satellites and spacecraft has driven the development of increasingly more capable in-space propulsion systems. This paper will summarize the current state of the art and on-going development efforts by U.S. and European propulsion interests. It covers areas of spacecraft propulsion that are in use (chemical and electric) or are undergoing a high level of engineering development (solar thermal). More advanced concepts, including nuclear and propellantless propulsion systems are covered in other papers at this symposium.

#### 1 Mission Classification and Market

In order to determine customer needs, a mission classification and market survey was carried out in 2000 based on a Euroconsult study. The following table shows the number of expected missions for each target orbit. The missions are scheduled for launch between 2000 and 2010, with a few exceptions out to 2014. Missions slated for launch within the next three years are considered as almost certain, but far term missions (more than five years out) are mostly speculative.

Table 1: Euroconsult Study of Scientific Launch Needs

Type of Mission	Mass Range [kg]	No. of Missions	Latest Mission [year]
LEO	100-1800	222	2014
MEO	650-6000	9	2007
GTO/GEO	150-6000	46	2010
Lunar	350-2100	7	2010
Heliocentric/Lagrange	900-3000	3	2009
Deep Space	100-2700	25	2010

The table shows that, by far, the most missions are planned for low Earth orbits (LEO), with those missions to geostationary (transfer) orbit (GTO/GEO) and deep space making up most of the rest. Only a few scientific spacecraft are planned for medium Earth (MEO), lunar, or to heliocentric/Lagrange point orbits.

Military satellites play a major role in the USA, and to a certain extent in Russia, but in Europe almost no market for military satellite applications exists (apart

with a few exceptions). Military satellites are not considered in the present mission categorization and the market survey. Within the context of the market survey and the mission classification advanced propulsion concepts will be presented and discussed.

## **2 Technology Needs derived from Market and Mission Analysis**

Due to limits on paper size, this overview will concentrate on the main drivers derived from market analyses and mission requirements. This seems to be an adequate approach, because there are two main motivations to invest in a technology:

1. The commercial market allows a return on industrial or partial industrial investment for a developed technology and product or
2. Agencies invest in a technology or product, which is critical for a specific mission.

Technologies which fulfill today's requirements will be described in this paper as a starting point to identify the direction of future developments. Alternatives and substitutes are also shown, which in some cases are mission enabling. The full range of missions is described in Table 2.

In addition to technology needs, there is increased economic pressure to reduce cost and lead-time for production. Industry is also being asked to reduce system and component design complexity. Adaptation of product design and the production process to incorporate modern production philosophies is another necessary step toward meeting market needs.

Table 2: Mission Summary

Mission:	Propulsion System sized to cope with	State of the Art Technology	Possible Development Direction	Alternative
Micro Spacecraft	<ul style="list-style-type: none"> <li>Attitude Control</li> <li>Station keeping</li> </ul>	Micro - Cold Gas Propulsion MEMS Phase change Micro Propulsion		Electric propulsion
Fundamental Physics and LEO earth science missions	<ul style="list-style-type: none"> <li>Attitude Control</li> <li>Drag free control (low continuous and continuously variable thrust)</li> </ul>	Helium proportional cold gas electric Propulsion FEEP		
LEO Astronomy	<ul style="list-style-type: none"> <li>Reaction wheel desaturation</li> <li>Slew maneuvers for target changing during missions</li> </ul>	Hydrazine Monopropellant	Green propellant	Electric propulsion
HEO, MEO Lagrangian points Earth Science missions	<ul style="list-style-type: none"> <li>Attitude Control relaxed requirements</li> <li>Reaction wheel desaturation</li> </ul>	Hydrazine Monopropellant	Green propellant	Electric propulsion
Big LEO / MEO Telecommunication Constellations	<ul style="list-style-type: none"> <li>Reaction wheel desaturation</li> <li>Orbit maintenance</li> </ul>	Hydrazine Monopropellant	Green propellant	Electric propulsion
Optical / IR remote sensing LEO (>450 km) missions	<ul style="list-style-type: none"> <li>Reaction wheel desaturation</li> <li>Orbit maintenance</li> </ul>	Hydrazine Monopropellant Bipropellant MMH N <sub>2</sub> O <sub>4</sub>	Green propellant Increased performance (I <sub>sp</sub> )	Electric propulsion
HEO MEO Lagrangian	<ul style="list-style-type: none"> <li>Reaction wheel desaturation</li> <li>Orbit insertion from initial LEO or GEO</li> </ul>	Bipropellant MMH N <sub>2</sub> O <sub>4</sub>	Green propellant Increased performance (I <sub>sp</sub> )	Electric propulsion
Geostationary telecommunications	<ul style="list-style-type: none"> <li>Orbit transfer</li> <li>Attitude control</li> <li>Station keeping</li> </ul>	Bipropellant MMH N <sub>2</sub> O <sub>4</sub> Bipropellant MMH N <sub>2</sub> O <sub>4</sub> / electric Propulsion Bipropellant MMH N <sub>2</sub> O <sub>4</sub> / electric Propulsion	Increased performance (I <sub>sp</sub> ) Reduce Complexity of System	Electric propulsion Electric propulsion Electric propulsion
Robotic space exploration	<ul style="list-style-type: none"> <li>Reaction wheel desaturation</li> <li>Planetary orbit maintenance</li> <li>Navigation maneuvers</li> </ul>	Bipropellant	Increased performance (I <sub>sp</sub> )	Electric propulsion
Robotic space exploration with sample return	<ul style="list-style-type: none"> <li>Reaction wheel desaturation</li> <li>Planetary orbit maintenance</li> <li>Navigation maneuvers</li> <li>Ascent stage from planet</li> </ul>	Bipropellant MMH N <sub>2</sub> O <sub>4</sub>	Increased performance (I <sub>sp</sub> )	
Human Exploration	<ul style="list-style-type: none"> <li>Fast transit outbound and inbound</li> </ul>	Nuclear thermal for Earth escape (Nerva derived)		Advanced nuclear thermal propulsion

### 3 State of the Art Propulsion

#### 3.1 Chemical Propulsion

Chemical propulsion systems have been the workhorse for spacecraft maneuvering needs since the dawn of spaceflight. Providing high thrust and concomitant rapid maneuvering capability, they have been utilized to provide all aspects of spacecraft propulsion including station keeping, orbit transfer, orbital rephrasing, and deorbit. Several varieties of chemical propulsion systems are utilized on operational spacecraft.

Over the past few years development work in the U.S. and Europe has concentrated on cost reduction measures by standardization and optimization of existing equipment designs with respect to recurring costs. Examples include the Globalstar and follow-on projects in the monopropellant area as well as the Eurostar and the Spacebus series within the bipropellant area.

Research and development efforts are exploring several areas, including increased performance, on-orbit storage, and ease of ground handling.

#### 3.2 Bipropellants

##### 3.2.1 Unified Propulsion System

One of the two successful European Bus series is the Spacebus line. The propulsion system manufactured by Astrium is integrated within the spacecraft structure. This Unified Propulsion System is shown in Figure 1.

Two propellant tanks are mounted into the structure's central tube. The pressurant vessels are fastened at their pole ends between the north and south webs of the spacecraft, with one free polar displacement fitting each, to allow for expansion.

The propulsion system is modularly designed within functional assemblies, the Pressure Control Assembly (PCA) and the Propellant Isolation Assembly (PIA). These modules are capable of being pre-integrated as assemblies on structural panels. This arrangement allows pre-integration of the subsystem, including proof pressure tests of the complete high pressure module, at the manufacturer's facility and allows parallel activities to be performed on the structure.

The propellant feed system is an all-welded design, which minimizes mass and ensures leak-tightness of

the subsystem as a whole. Screwed connections are used only for the connection of the 400 N motor and the 10 N thrusters. This allows easy mounting and dismantling of these components at the system level if required.

The apogee motor is located on the centerline of the spacecraft (z-axis) in the lower part of the central tube. It is fixed by four screws to the central mounting plate of the support structure. The alignment of the 400 N motor is achieved by positioning shims between the separation ring brackets and the support structure.

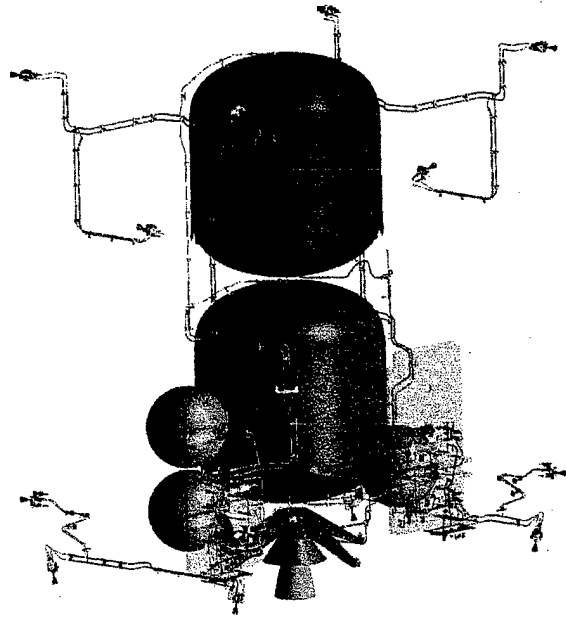

Figure 1: Typical Unified Propulsion Design Layout

##### 3.2.2 Reaction Control Thrusters

State of the art reaction control thrusters fulfill the requirements for lifetime and minimum impulse bit. The balance between thrust requirements for apogee auxiliary maneuvers or backup performance on one side and minimum impulse bit on the other is fulfilled with existing RCS thrusters at the 10 N and 22 N thrust levels. The Astrium Platinum 10N thruster is shown in Figure 2.

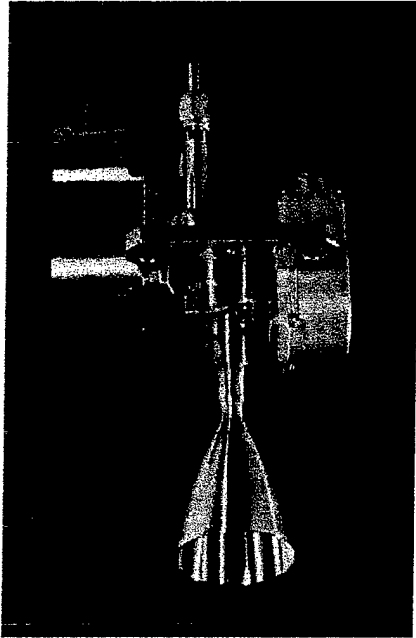

Figure 2: Astrium Platinum 10 N Thruster

### 3.2.3 Apogee Boost Motors

Prior to 1980, a majority of satellites were positioned in geostationary orbit by solid apogee boost motors and used monopropellant systems for orbit corrections and attitude-control. In 1974 the Franco-German communication satellite Symphonie was the first European satellite to use a bipropellant system for apogee boost into geostationary orbit and for orbit corrections.

The advantage of the liquid apogee motor lies in its capability to provide precise Delta V. They do not have the temperature isolation requirements of solid motors, where temperature variation affects thrust level and shut off time. The need for precise Delta V is driven by the need to compensate for the small errors in the launch orbit. Although the safety criteria for handling spacecraft with liquid or solid motors are quite different, both systems have very critical safety aspects.

Aerojet<sup>1</sup> has experience with bipropellant rocket engines dating back to its Kaiser Marquardt heritage. Early space programs include development of the R-4D for the Apollo lunar landing program. Current applications include Liquid Apogee Insertion (LAE) engines for orbit raising of many geosynchronous spacecraft, including those built by Boeing Satellite Systems. Most Aerojet rocket engines operate with monomethyl hydrazine and nitrogen tetroxide, but

they are currently completing qualification of a Dual Mode High Performance Apogee Thruster (HiPAT™) which operates on hydrazine and nitrogen tetroxide. Dual mode engines are particularly useful when paired with monopropellant hydrazine thrusters for ACS and hydrazine arcjets for station-keeping activities.



Figure 3: Aerojet Dual Mode R-4D 100 lbf HiPAT™ in Qualification Testing

### 3.2.4 Advanced Materials

In order to fulfill market requirements Astrium is developing an LAE with increased specific impulse. The increase in specific impulse ( $I_{sp}$ ) is achieved by usage of ceramics as chamber material and a modified injection system. Figure 4 shows this thruster during hot-fire testing. The goal is to achieve an  $I_{sp} > 325$  s in order to save some 20 to 40 kg of propellant mass.

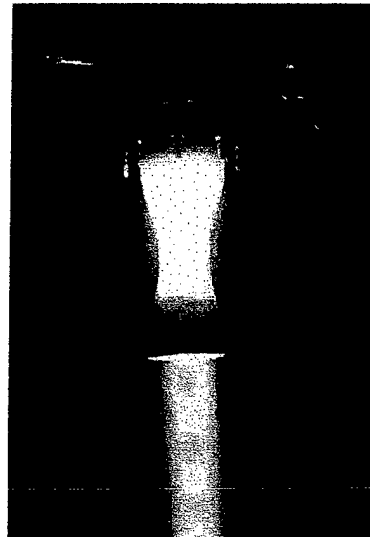

Figure 4: Hot Fire Test of 400 N C/SiC thruster

### 3.2.5 Advanced Bipropellant Fuels

Northrop Grumman Space Technology (NGST)<sup>2</sup> is actively developing a reaction control system (RCS) thruster using non-toxic propellants for an operationally efficient and reusable auxiliary propulsion system (APS). Non-toxic propellants improve safety by eliminating hazards at the launch pad, test and maintenance facilities, as well as on-orbit for manned missions. For reusable space vehicles, improved safety makes ground processing simpler and, therefore, reduces turnaround time and effort. The objective of this effort is to develop an integrated primary/vernier thruster capable of providing both 1000-lbf-class thrust and 25-lbf thrust levels. Both LOX/LH<sub>2</sub> and LOX/ethanol versions are being evaluated. Dual-thrust non-toxic RCS engines would be used for an upper stage or space vehicle with a range of reaction control thrust requirements (i.e. high thrust for control authority and low thrust for minimum impulse).

Atlantic Research Corporation<sup>3</sup> liquid propulsion has continued its development of a next generation bipropellant station keeping thruster for satellites. This new thruster uses an uncoated platinum/rhodium alloy thrust chamber and an injector specifically designed for use with the chamber to improve both steady state and pulsing performance. The chamber has demonstrated over 2,000 lbm of propellant throughput with no signs of degradation. The engine delivers 5 lbf of thrust at a nominal feed pressure of 220 psia with a specific impulse of 300 s. Satisfactory performance has been demonstrated over a wide range of operating conditions including a mixture ratio range of 1.0 – 2.1 and feed pressures from 140 – 400 psia. Execution of a formal qualification test program is anticipated later in 2003.

Purdue University<sup>4</sup> has been developing nontoxic propellants based on hydrogen peroxide as an oxidizer. Under this program, they will be testing dimethylaminoethylazide (DMAZ) combustion of hydrogen peroxide decomposition products via the use of a catalytic bed staged combustion thruster. New hypergolic fuels based on kerosene and JP fuels are also being developed by Swift Enterprises as a part of this project. Purdue is also working on advanced injector designs for a new generation of LOX/hydrocarbon booster engines currently under development by NASA. They are developing Russian-style coaxial injectors that are attractive candidates for an oxidizer-rich staged combustion cycle.

### 3.3 Monopropellants

A defacto standardization of European monopropellant systems has been achieved, especially for LEO applications. This development was mainly driven and achieved by the Globalstar constellation, as shown in the following figures.

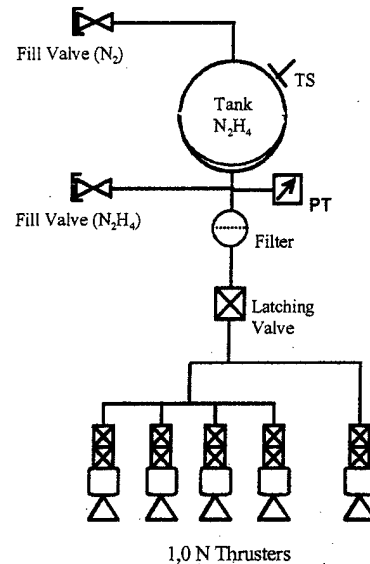

Figure 5: Globalstar Flow Schematic

The equipment shown is interconnected by means of ¼ or ½ inch titanium tubing up to last part prior to the thrusters. In general, joints to the manifolds and components are welded connections. In order to support the demand for easy field repair, the highly reliable MS 33656-4 fitting is used at the propellant tank downstream side, pressure transducer, and thruster interfaces.

The propellant and pressurant are loaded through dedicated fill and drain valves. A system propellant filter is installed downstream of the tank in order to safeguard the seat/seal arrangements in the thruster valves. Each thruster is equipped with a series redundant flow control valve, which features two independently switchable coils and two seat/seal arrangements in the flow path. Both valves must be opened simultaneously with the same command to achieve thruster firing. The standard thruster is provided with a redundant catalyst bed heater element consuming about 3.2 W per heater element and 6.4 W per thruster. The flow control valve has a power consumption of 10.2 W at a nominal 28 VDC. The pressure conditions during loading of the Reaction Control Subsystem and during the entire mission can be monitored by means of a pressure

transducer. The Reaction Control Subsystem provides the capability to perform all kinds of orbit maneuvers by providing the required Delta-V by hot firing in the steady state, off-modulation, and pulsed modes.

Standardized interfaces to AOCS and Thermal Control have been developed as shown in the following figures:

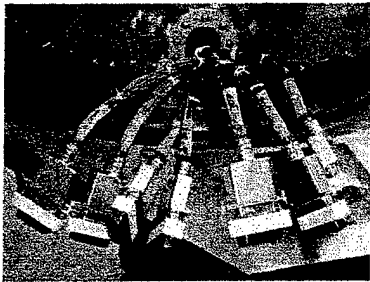

Figure 6: Standardized AOCS & IOS Interface

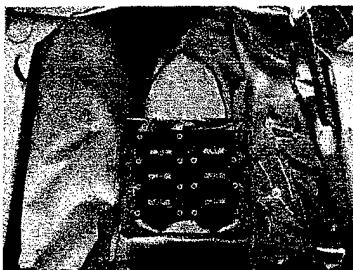

Figure 7: Standardized Thermal Control Interface

This approach allows an autonomous checkout of the complete subsystem. The plug-in concept minimizes duration and risk during system integration. The full ROCSAT-2 modular monopropellant system is shown in Figure 8.



Figure 8: Modular Monopropellant System (ROCSAT-2)

The flexibility of this concept will be improved by ensuring compatibility with various bus voltages, usage of thrusters with different thrust levels, and

coverage of mechanical loads of various launchers. The equipment which is used for this type of propulsion system has been qualified and optimized with respect to production costs and is manufactured in series. The concept has been selected and accepted by various customers due to its low risk and cost effectiveness, achieved by a high degree of common manufacturing, integration, and testing. Nevertheless market surveys and investigation have been performed in order to check whether advanced propulsion concepts and technologies can improve the compliance with customers needs with respect to performance and costs.

Aerojet's<sup>5</sup> experience with monopropellant rocket engines dates back to its Rocket Research heritage. Early space programs include the Viking Mars Landers (1976) and Voyager 1 and 2, now the farthest man-made objects in the galaxy and still operational after a 1977 launch. Most Aerojet monopropellant rocket engines operate with hydrazine on a spontaneous catalyst bed. They continue to upgrade and test hydrazine thrusters and propulsion systems for new and expanded applications. Recent users include the Air Force's GPS Block IIF and NASA Discovery Missions. Individual thruster units have also been utilized for most recent NASA Mars missions.

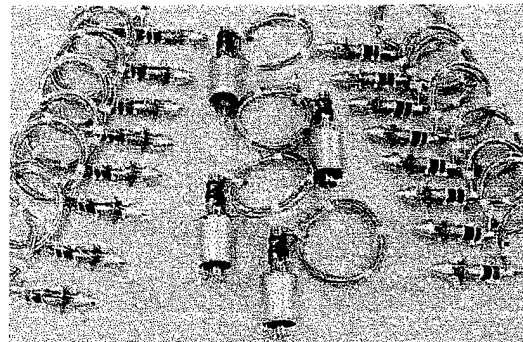

Figure 9: Aerojet 1 N and 20 N Monopropellant Hydrazine Thrusters for the ADEOS II Earth Observing Spacecraft

Moving beyond hydrazine, Aerojet has significant current research and development efforts aimed at developing reduced toxicity propellants for next generation spacecraft applications. The goal of this program is to demonstrate a substantial increase in delivered density-specific impulse over hydrazine. The propellants of interest in this technology development have low toxicity (green) and a much higher energy density than hydrazine which leads to a significantly higher exothermic decomposition temperature. The primary technical challenge is to

overcome the materials limitations in regard to the high exothermic decomposition temperatures.

Research at the Pennsylvania State University and Princeton University<sup>6</sup> has been underway to design, fabricate and test liquid-propellant chemical microthrusters for propulsion of small and micro-spacecraft. The unique features of the microthrusters are: (1) environmentally friendly, liquid propellant formulations, (2) simplicity of design (3) the use of electrolytic ignition (4) asymmetric whirl combustion for gas-phase combustion stabilization, and (5) stereolithographic fabrication techniques. Liquid homogeneous monopropellants are desirable for operation of microthrusters because of system simplicity.

### 3.4 Cold Gas

VACCO<sup>7</sup> has developed a micro propulsion system based on their Chemically Etched Micro Systems (ChEMS™) manufacturing technology. This system combines a ChEMS™ thruster manifold with system-in-a-tank construction locating all functional components inside the propellant storage tank. This maximizes propellant storage volume within the given overall envelope. Valve actuators, transducers, and PC board electronics are immersed in the Isobutane propellant. The system is a titanium weldment 3.6" x 3.6" x 0.95" (about half the size of a VHS videocassette). Four ChEMS™ 50 mN micro-thruster nozzles are located around the periphery of the module and a single axial 75 mN Micro-Thruster nozzle is located in the center of the X-Y plane facing in the +Z direction. (See Figure 10). The compact system weighs 485 grams empty with a propellant storage volume of 96 cc. This system is scheduled to fly on the Aerospace Corporation's MEMS PicoSat Inspector (MEPSI) CubeSat.

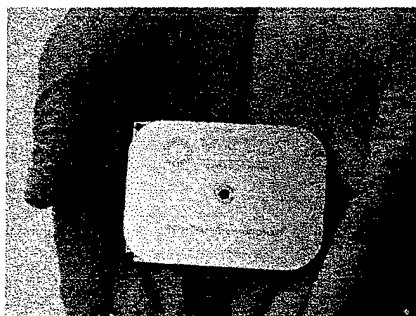

Figure 10: VACCO's MEPSI Micropropulsion System

## 3.5 Electric Propulsion

### 3.5.1 Resistojets

Resistojets are, perhaps, the simplest form of electric propulsion. They provide heat to increase the energy of the operating medium,  $\text{GN}_2$  e.g. or the decomposition products of a standard monopropellant thruster.

After a hiatus in the development of electrothermal thrusters for on-orbit propulsion of spacecraft during the 1960's and 1970's, the increase in size and power availability on operational spacecraft spurred renewed interest in their use on geostationary telecommunication satellites in the early 1980's. At that time, Rocket Research Company<sup>24</sup> (now Aerojet, Redmond) started a program to develop hydrazine resistojets for North-South Stationkeeping applications on geostationary spacecraft. Invented by Gordon Cann, these Electrothermal Hydrazine Thrusters (EHTs) use a high temperature heat exchanger to heat the hydrazine decomposition products from a standard catalytic hydrazine monopropellant thruster to augment its performance to about 300 s of specific impulse or 1.5 times the specific impulse of the catalytic thruster. These EHTs were the first electric propulsion devices to fly on operational commercial satellites. As of early 2003, more than 220 resistojets of the MR-501 and MR-502 classes have been delivered and successfully flown on geostationary spacecraft and the Iridium constellation.

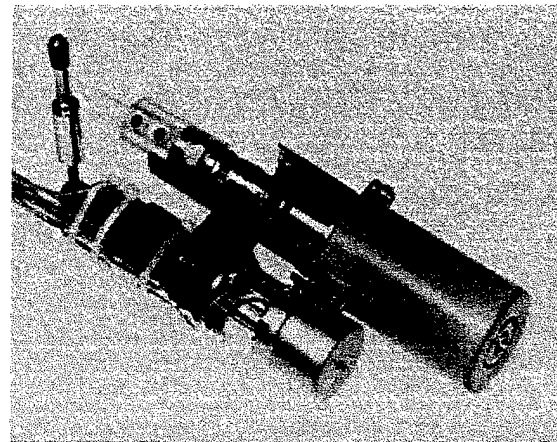

Figure 11: The MR-501B EHT resistojets represents the first generation of electrothermal thrusters developed by Aerojet

### 3.5.2 Arcjets

In an arcjet thruster, a high temperature electric arc ( $T > 15000\text{ K}$ ) is used to partially ionize and heat a propellant to increase its energy. In the late 1980s, their success with hydrazine resistojets led Aerojet<sup>24</sup> to develop hydrazine arcjets for stationkeeping applications. The first arcjet system was flown in 1993 on the commercial GE-Astro (now Lockheed-Martin) Telstar 401 telecommunication spacecraft. This operational commercial application was also the first arcjet ever flown, without any previous thrusters flown on experimental missions. Since then, more than 130 arcjets and their power conditioning units (PCUs) have been flown on more than 33 spacecraft, providing reliable service in some cases for more than eight years.

Specific impulses of 600 s are currently state of the art for hydrazine arcjets regularly used for stationkeeping applications. A dedicated PCU converts electric power from the spacecraft's batteries into the DC-arc of the thruster. A typical system for a geostationary spacecraft consists of four thrusters with their power supply (Figure 12). For a typical weekly stationkeeping maneuver, two of these four thrusters are operated in parallel, consuming 2 kW of electric power per thruster.

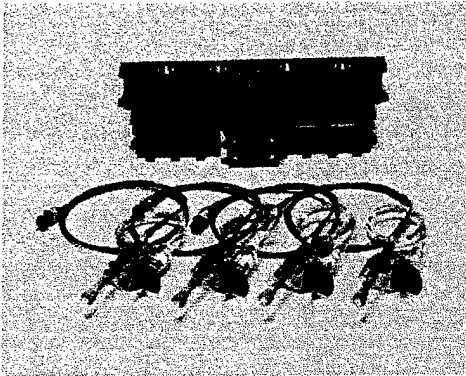

Figure 12: Typical Shipset of MR-510 Hydrazine Arcjets for a Geostationary Spacecraft

### 3.5.3 Ion Engines

Ion engines have entered the commercial marketplace for use on geosynchronous communications satellites. Boeing Satellite Systems Xenon Ion Propulsion Systems (XIPS) are available on Boeing 601HP and Boeing 702 satellites.<sup>8</sup> The 601HP uses four (two primary, two redundant) 13 cm XIPS engines operating at 500 W for north-south stationkeeping and two-axis momentum control. The

13 cm XIPS operates at a specific impulse of 2568 s and 18 mN of thrust. The 702 satellite uses four 25 cm XIPS engines operating at 4.5 kW to perform stationkeeping and momentum control as well as offering the capability to perform orbit raising to further save propellant by circularizing and finalizing the satellite's orbit. The 25 cm XIPS operates at 3800 s specific impulse with 165 mN of thrust. The first commercial ion engine was launched in 1997 on the PAS-5 satellite. In 2002, Boeing launched three 601HP satellites and three 702 satellites, all with ion engines.<sup>9</sup>

With the launch of ESA's Artemis satellite in July 2001 Europe brought their first "operational" ion propulsion system into orbit to demonstrate North-South-station-keeping. This technology saved the Artemis mission after a launch failure stranded the spacecraft in too low of a transfer orbit.<sup>10,11,12</sup> The orbit raising/rescue maneuver of the Artemis satellite with a RIT-10 ion engine propulsion system occurred over nine months, raising the satellite from a 31000 km parking orbit to its proper GEO position, completing 5860 hours in high thrust mode.

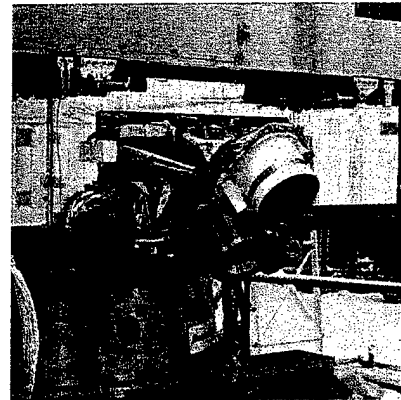

Figure 13: Ion Propulsion Thrusters on Artemis

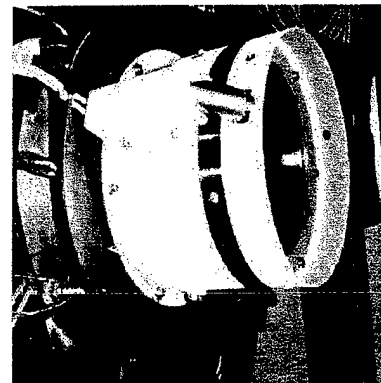

Figure 14: Astrium RIT-10 Thruster

This successful mission application proved the adequacy of the life qualification performed in the customer's facility at ESTEC. The RIT-10 ion thruster assembly for ARTEMIS, after an initial problem caused by the test environment<sup>13,14</sup> showed excellent and stable performance with data significantly better than the specification over more than 2.5 years. It successfully completed the 15000 hour life verification and has demonstrated a significantly higher life capability. The test was terminated at 20000 hours of successful operation. Inspections in combination with a grid erosion model and electron back streaming measurements indicate a substantially higher life capability at an "EOL = 15000 hour" specific impulse of 3370s (average of 3420 s) which is substantially higher than the required 3000 s.<sup>15,16</sup>

### 3.5.4 Hall Effect Thrusters

In addition, Europe has developed Hall effect thruster (HET) technology. Two satellites applying this technology, the Stentor technology demonstrator, built by Astrium and Alcatel for the customer CNES, and Astra 1K, built by Alcatel, were launched in 2002. Unfortunately, both were lost due to launcher failures. Two major European satellite manufacturers, Astrium and Alcatel Space, have chosen to use the Hall effect technology based on Fakel's SPT-100 for new commercial GEO buses. SMART-1 will be the first European scientific satellite to apply electric propulsion for a lunar transfer. It is scheduled for launch in 2003.

For the next generation of high power geosynchronous satellites, the application driving the requirements will remain stationkeeping, which results in a moderate thrust range between 120 mN and 170 mN at high specific impulses above 4000 s.<sup>17</sup> Orbit raising will be limited to short phases of orbit topping to enable satellite users to start service as soon as possible after launch. For scientific applications, the whole bandwidth from micro Newtons to Newtons will be needed to enable a range of missions from very fine positioning or orientation up to high Delta-V requirements for deep space missions. In order to keep the satellites as small and lightweight as possible to minimize launch costs, high specific impulse at low power levels will be the key requirement. For future manned missions to the outer planets nuclear electric propulsion technologies able to deliver very high thrust will be needed.

## 4 Developments in Progress

### 4.1 Advanced Chemical Propellants

Space exploration and utilization require vehicles that are operable, safe, and reliable. Technologies for improving rocket performance are also desirable. As space missions become more ambitious, the need for reducing cost and increasing the capability of rocket systems will increase. Improved chemical propellants have the power to make space flight more affordable and deliver higher performance.

Rocket propellant and propulsion technology improvements can reduce the development time and operational costs of new space vehicle programs, and advanced propellant technologies can make space vehicles safer and easier to operate, and can improve their performance. Several areas have been identified for research.

#### 4.1.1 Non-toxic Spacecraft Propulsion

The goal of reducing life cycle costs and simplifying propulsion subsystems has led to the development of propellants for spacecraft propulsion with significantly less toxicity than commonly used hydrazine and hypergolic MMH and NTO. While current storable propellants have excellent properties for in-space application they have the disadvantage being highly toxic. They require extraordinary precautions in order to protect the ground crew during propellant handling. The rationale behind these efforts is the elimination of safety-driven inhibits and the simplification of on-ground and manned operations and logistics when propellants are present. To overcome performance deficits of existing non-toxic propellants and to increase the financial return to offset additional verification expenses, propulsion propellant developers are aiming at improving both specific impulse and density beyond the values currently realized by conventional, toxic propellants.

Among non-toxic, or "green" propellants hydrogen peroxide is a candidate of high interest. It fulfils the requirements of storable propellants: being liquid at room temperature, being dense (1.3 g/cm<sup>3</sup>, 70%), being energetic, and being hypergolic. Hydrogen peroxide has been used for monopropellant thrusters, and as an oxidizer in both bipropellant and hybrid rocket engines

Renewed interest in hydrogen peroxide is being driven by new technologies for the catalyst capable

of 100% hydrogen peroxide decomposition and resistance against poisoning by peroxide stabilizers. Today, existing engine technologies produce about 96 % of the specific impulse of MMH/NTO at about 12% greater density. The challenge is to show that hydrogen peroxide is storable and safe. It slowly decomposes to lower concentrations, typically a rate of 1% peroxide loss per year. New technology will allow the concentration of peroxide with fewer of the impurities that promote decomposition and methods of measuring these minimal concentrations to assure high peroxide quality and storability.

State-of-the-art green propulsion missions have modest Delta V requirements. The Surrey Satellite Technology Ltd. (SSTL) UoSAT-12 spacecraft<sup>18</sup> flew a traditional cold gas nitrogen system and a nitrous oxide resistojet system, using a SSTL-designed 100 W resistojet. Most recent SSTL projects have used butane as their propellant, due to its good density specific impulse and very low storage pressure. The SNAP-1 nano-satellite (total mass 6.5 kg) flew a 450 g propulsion system containing 32.6 g of butane. ALSAT-1 is currently flying a butane system with a SSTL-designed 15 W resistojet.

Significant work has been done at SSTL<sup>19</sup> to develop a monopropellant nitrous oxide thruster using catalytic decomposition. The other green propellant of choice is hydrogen peroxide for use in bipropellant engines. Figure 15 shows the sea level hot fire testing of the bipropellant engine. It uses catalytically decomposed hydrogen peroxide in combination with kerosene to produce around 40 N of thrust. This combination has a higher density specific impulse than traditional NTO/MMH bipropellant systems, hence has good potential in small spacecraft where volume constraints are often greater than mass constraints.

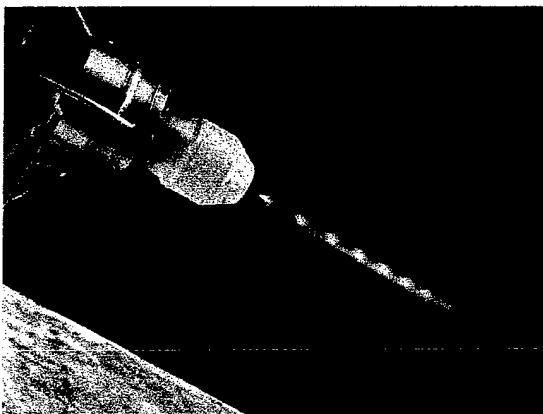

Figure 15: SSTL Hydrogen Peroxide/Kerosene Bipropellant Engine

Other European institutions are developing propellants with a high potential for performance increase, including aqueous solutions of

- Hydroxyl Ammonium Nitrate (HAN)
- Ammonium-Dinitramide (ADN)
- Hydrazinium Nitroformate (HNF).

These propellant formulations can be used as monopropellants or, in combination with a suitable fuel and a dedicated ignition system, as bi-propellants. In addition, being solid salts, their pure formulations can be envisaged also as solid rocket propellants or for hybrid propulsion.

In France, CNES<sup>20</sup>, the French Space Agency, is pursuing research and technology programs on new green monopropellants such as HAN with TEAN (Triethanolammonium nitrate), water, and hydrogen peroxide. CNRS, the French National Center for Scientific Research, is developing the catalyst, using new experimental set-ups (batch reactor, dynamic reactor) and the new propellants (produced by CNRS or other European institutes. Between the different propellants and catalysts, a trade has to be made between performance and safety.

Swedish Space Corporation (SSC)<sup>21</sup> is developing an ADN-based monopropellant. Tests have demonstrated feasibility in the firing of a small experimental thruster.

HNF based propellants have been pursued in Europe by the Dutch company TNO-PML since 1998<sup>22</sup>. Research is focused on increasing performance by the addition of fuels in aqueous HNF solutions.

#### 4.1.2 Gel Propellants

NGST<sup>2</sup> has been actively advancing Gel propellant technology for many years. The traditional focus has been tactical gel propulsion applications; however recent studies have shown that gel propellants provide favorable characteristics for in-space propulsion as well. The attraction for such systems is credited to their inherent safety and long term storability. These features, combined with the ability to provide passive low temperature storage and operation, make gel propulsion technology a strong candidate for in-space applications. For example, NASA has identified Gel propulsion as the optimum propulsion system for the Mars Ascent Vehicle (MAV). The MAV is a key component for returning Mars surface samples to earth by accurately inserting

a sample container into Mars orbit for rendezvous and capture by an orbiting return vehicle.

#### 4.1.3 Hybrid propulsion

There has been renewed interest recently in hybrid rocket propulsion systems. For example, Space Dev of Poway, CA is developing this safe and low cost technology that has benefits for current and future space missions. Space Dev's hybrid rocket propulsion technology features an elegantly simple design, the ability to be restarted, and is throttleable. Additional benefits include the ease of transportation, handling, and storage. The Space Dev system uses non-toxic Plexiglas as a fuel and nitrous oxide as an oxidizer. Low thrust systems will be pressure fed, but larger thrusters will require a gas turbine for oxidizer feed.

### 4.2 Electric Propulsion

#### 4.2.1 Electrostatic

##### 4.2.1.1 Hall Thrusters

Hall effect thrusters are electrostatic devices that use a magnetic field to trap injected electrons. These electrons serve to ionize injected propellant, typically a heavy noble gas such as xenon, and act as a virtual cathode for propellant acceleration. Hall thrusters offer many advantages including an attractive combination of high specific impulse (as compared to chemical thrusters) and high thrust-to-power ratio (as compared to ion thrusters). The net result is a fuel-efficient transfer with a reasonable trip time.

Two tasks are central to the NASA GRC Research Center<sup>23</sup> Hall thruster program: 1.) the development of a laboratory Hall thruster capable of providing high thrust at high power; 2.) investigations into operation of Hall thrusters to understand optimization criteria for new designs. High power thruster development is being emphasized because recent mission analyses have shown a need for higher power electric propulsion systems for both orbital and deep space applications. Orbital applications benefit from higher thrust systems to reduce trip time. Deep space, large Delta-V, missions typically require higher specific impulse to reduce fuel loading. Power rich spacecraft architectures provide an opportunity to take advantage of propulsion systems that provide both high power and high specific impulse. As mass is allowed to increase for a mission, the optimum specific impulse tends to decrease. The application of Hall thrusters to these

missions requires increased performance, reduced mass, and longer life.

The first task resulted in investigations of the issues associated with scaling a single thruster to power levels substantially in excess of the state-of-the-art. A 50-kW class Hall thruster was designed, built, and operated over the range of 9 – 72 kW. The second task has focused on investigating factors critical to higher specific impulse operation. Recent NASA GRC work in this area has considered the role of magnetic field topography on high voltage operation.

As a follow-on effort to their in-house thruster development, NASA GRC has funded Aerojet RRC to develop a 50 kW Hall thruster. Aerojet's unique 50 kW design employs a magnetic field configuration designed to double the lifetime over existing state of the art Hall thrusters and improve performance. The Aerojet 50 kW Hall thruster operates at twice the power density of state of the art Hall thrusters.

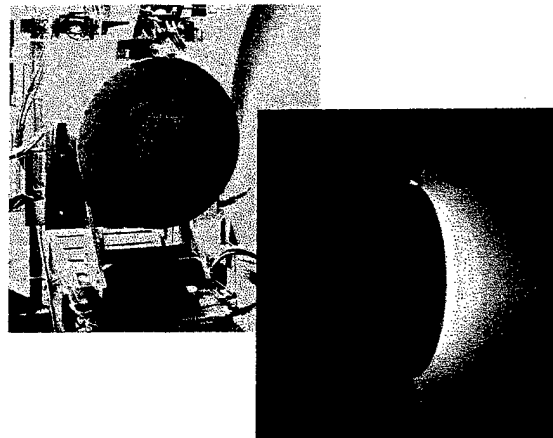

Figure 16: Aerojet MSAT 50 kW Hall Thruster

In addition to their high power thruster work for NASA, since early 1994 Aerojet<sup>24</sup> has been working on Hall thruster system technologies targeted at the LEO and GEO communication satellite marketplace. Early work included the development and integration of a Hall thruster system for the Space Technology Experiment (STEX) satellite. Aerojet served as the systems integrator and developed a 1.5 kW class power processing unit (PPU) for a D-55 Tsnimash anode layer thruster.

In mid-1997, Aerojet (then Primex Aerospace Company) teamed with the Busek Co. to develop the BPT series of thrusters which provided the first all US commercial Hall thrusters. Early development included testing of over 100 thruster configurations and preliminary flight model development of a 2 kW

and a 4 kW class thruster. Extensive work was also focused on extending and demonstrating thruster life capability. These efforts included extended duration testing at three different power levels and development of a very accurate, semi-empirical insulator erosion model. The BPT-4000 laboratory model thruster, designed and built in 1998, was the culmination of this work. The thruster was put through an accelerated life test demonstrating the greater than 6,000 hour life capability of the design.

Aerojet also put significant company resources toward the development of cathode, power processor, and xenon flow controller technologies for the BPT thruster series. In the realm of cathode technology, Aerojet developed a low cost design based off of the NASA space station plasma contactor. The Aerojet approach incorporates all of the key functional elements of the NASA design but has a greatly reduced parts count and simplified joining operations which were the outcome of a design for manufacturability and assembly (DFMA) effort. A 4 kW class breadboard power processor was also developed leveraging off of the heritage of the STEX PPU. The PPU incorporated a single patented power supply design for operating the thruster magnets and the cathode heater and keeper with a single switching supply as well as other enhancements to improve performance and reliability and reduce mass and cost.

The culmination of these technology demonstration efforts was the joint Lockheed Martin-Aerojet effort to develop a Hall Thruster Propulsion System (HTPS) for space communication satellites. Aerojet's portion of this endeavor includes an enhanced dual mode BPT-4000 thruster, the associated power processor and the xenon flow controller (XFC) which is provided by Moog under a subcontract as well as system integration. All components have completed a successful lightweight engineering development model program and qualification units have been fabricated and are currently in qualification testing. Extensive system modeling and testing have also been performed. The BPT-4000 4.5 kW class thruster will be qualified to operate over a range of voltages and powers to provide high thrust for orbit raising or repositioning and high specific impulse for stationkeeping. The enhanced BPT-4000 leveraged work done for AFRL and NASA GRC which explored the extension of the efficient operating range of Hall thruster to lower voltages in order to provide higher thrust to power ratios. The qualification test of this thruster will demonstrate over 5600 hours of operation.

NGST is the prime contractor for an effort to develop a 200 W Hall thruster propulsion system. The NGST<sup>2</sup> team includes Busek Co. for the development of the thruster and the cathode, and Moog, Inc. for the development of the xenon feed system (XFS). NGST is responsible for the development of the PPU, as well as the system engineering, integration, and qualification testing. To date, a propulsion system engineering-model (EM) has been successfully tested in vacuum. Additional system qualification testing will take place in FY 2003.

The Busek<sup>25</sup> BHT-200 200-W Hall thruster and BHC-1500 hollow cathode (Figure 17) are derived from products developed under Small Business Innovative Research (SBIR) programs. The engineering model thruster and cathode weigh approximately 1.1 kg. During thruster/cathode qualification and acceptance testing the specific impulse has been measured at over 1350 s and the overall thruster propulsive efficiency at more than 37%. This includes all losses and cathode flow. The thruster also operates in a pulsed mode for delivering precise, variable impulse-bits less than 2 mN-sec.

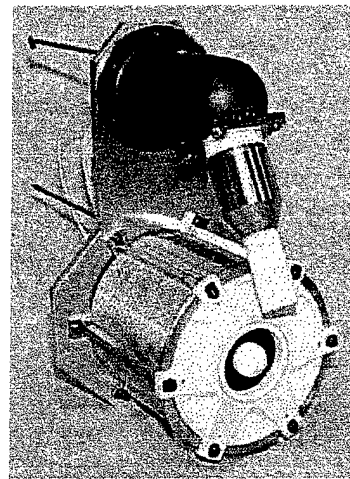

Figure 17: Busek's engineering model 200 W Hall thruster and hollow cathode

Several other Hall thruster efforts are underway at Busek. Under a Phase II SBIR contract, Busek is developing 600 W Hall thrusters specifically intended for use in a clustered configuration as part of an ongoing effort to investigate issues related to clustering Hall thrusters to provide high power capabilities. As part of the next phase of this effort, Busek has been developing a novel, nominal 8 kW Hall thruster, the BHT-8000, capable of multi-mode operation over a broad range of specific impulse and thrust. During laboratory testing specific impulses from as low as 1200 s to as high as 3500 s were

measured. Anode thrust efficiency exceeding 66% has been achieved. The size and performance of the BHT-8000 provides a good balance between efficiency, size, and modularity.

United Technologies, Pratt & Whitney Space Propulsion<sup>26</sup> continues to work on the development of Hall Effect Thrusters, based upon the HET technology acquired from Space Power, Inc. in 2001. Throughout the past two years, a series of successful tests have been performed on a large Pratt & Whitney HET known as the T-220HT. The reproducible performance measured during these tests of the T-220HT has shown that this thruster works well in producing the required thrust and specific impulse at the power levels of interest for satellite orbit transfer applications, as well as for stationkeeping. The engine was also demonstrated to be compatible with a prototype PPU constructed by Hamilton Sundstrand. The T-220HT has demonstrated successful operation in the power range of 2 – 22 kW with thrust levels exceeding 1 N (1.18 N measured at 18.3 kW).

The Massachusetts Institute of Technology (MIT)<sup>27</sup> is developing and refining numerical methods for predicting the performance, life, and internal plasma details of high specific impulse Hall thrusters. Numerical work is ongoing to adapt and extend a previously existing PIC model and to perform experimental measurements to verify this model. Work being done will be used to model the interaction of the Hall thruster plume and the spacecraft itself, including sputtering, deposition, a variety of collisional processes.

Michigan Technological University<sup>28</sup> has initiated a project to utilize bismuth as a Hall thruster propellant to take advantage of its high atomic mass and low ionization potential.

European industrial centers, especially Snecma and Astrium have been working to develop Hall thrusters since the 1990's.

In order to allow large space platforms with payload powers up to 25 kW to benefit from the use of plasma propulsion, Snecma Moteurs started preparatory work in 1999 for the development of a new high power Hall effect thruster with the support of CNES and in cooperation with the Russian design bureau FAKEL. This effort led to the design of the PPS<sup>®</sup>X000, a prototype model of a high power (up to 6 kW) Hall effect thruster with dual-mode capability

able to meet the propulsive needs of next-generation geostationary satellites.

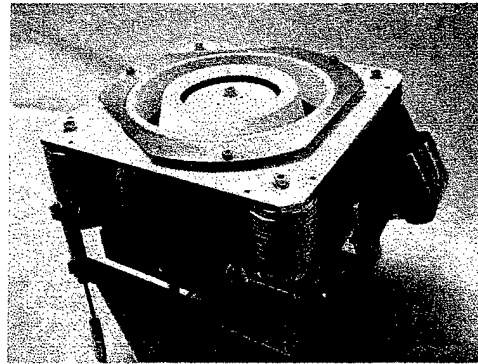

Figure 18: Snecma PPS<sup>®</sup>X000 Development Model

The twofold goals of the PPS<sup>®</sup>X000 technology demonstrator were to demonstrate, as close as possible to full scale, the feasibility and effectiveness of technologies required for high power Hall-effect thrusters, e.g., new coil wires, improved radial heat conduction within the internal coil, thermal drains to reduce inner coil temperature, and anode design adapted to high thermal loads; and to allow experimental parametric testing of magnetic configurations, axial positions of the gas distributor and ceramic discharge channel, discharge voltages, and the impact of ceramic wall erosion on performance stability.

Extensive characterization testing completed by the end of 2002 demonstrated a considerable range of stable operating conditions for a given thruster configuration. In particular, a thrust level of  $340 \pm 10$  mN was measured at 6kW and 300V, while a maximum total specific impulse of  $2480 \pm 107$  s and total efficiency of  $55.6 \pm 6.6\%$  were measured under discharge conditions of 5kW and 585V.

The PPS<sup>®</sup>X000 design is based fully on Snecma Moteurs patents, consistent with a totally independent European design and product. The effort pursued so far has paved the road for the successful development of a Hall effect thruster with performance consistent with the requirements of the  $\alpha$ -Bus program.

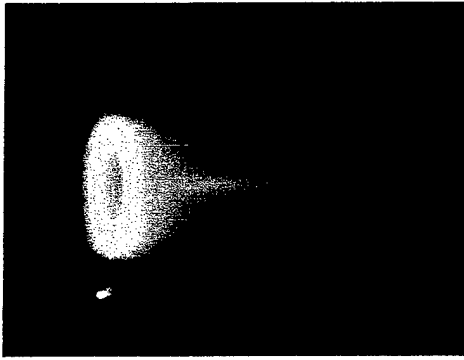

Figure 19: Snecma's engineering model of the PPS®X000 Hall thruster during performance testing

With CNES support and in partnership with the MIREA (Moscow Institute of Radioelectronics and Automatics) Snecma, is studying a 2-stage Hall effect thruster with ionization and acceleration zones separated. Tests of prototypes have demonstrated the feasibility of the principle<sup>29</sup>.

Astrium, which currently uses the SPT-100 on its EUROSTAR 3000 busses, is developing a thruster of somewhat lower thrust/power level, designed to be used on their current buses which requires a longer lifetime and higher total impulse than the SPT-100. Supported by ESA in cooperation with the Keldysh Institute in Moscow, Inasmet in Spain, and QinetiQ in UK Astrium has developed the ROS 2000, a thruster built purely of European / Western Standard parts.

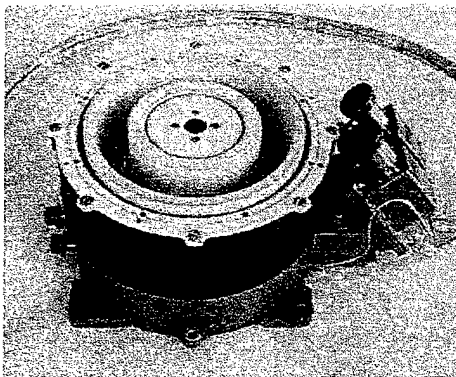

Figure 20: Pathfinder model for Astrium's ROS 2000 Hall thruster

Thales Aerospace, with the support of the DLR and CNES, is working on an innovative High Efficient Multistage Plasma (HEMP) thruster concept, which focuses an ion beam in a multi-stage magnetic cusp structure.<sup>30</sup> An efficiency exceeding 30 % for a 600 W thruster operating at 1680 s specific impulse

was demonstrated in July 2002 in the ONERA test facilities. New optimized models have already been designed and will be tested soon.

#### 4.2.1.2 Ion Engines

Ion engines utilize charged grids to accelerate ions to very high velocities. The resultant specific impulses are typically in the range of 3000 to 15000 s. Ion engine development has been underway at NASA for over 40 years. Early work concentrated on mercury and cesium propellants, but over the last 20 years, the transition has been made to xenon due to testing and operational contamination concerns. These high specific impulses make ion engines ideal for NASA interplanetary and deep space missions. Mission studies indicate that several broad categories of engine systems are desirable. These categories span power ranges from 100W to >10kW with clustering to achieve higher powers. Missions range from visits to relatively near-by bodies to trips as far as 100 AU. The goal of NASA's ion engine development program is to develop key technologies, thrusters, and systems for this range of missions.

The culmination of ion engine development work at the NASA GRC Research Center<sup>25</sup> and the Jet Propulsion Laboratory<sup>31</sup> in the 1990's was the flight of NASA's Solar Electric Propulsion Technology Application Readiness (NSTAR) 30 cm ion engine on the Deep Space 1 mission. This mission was successfully completed in December 2001 with the NSTAR engine (see Figure 21) accumulating 16265 hours of operation. A concurrent Extended Life Test performed at JPL on the NSTAR flight spare has passed 27000 hours of operation. The NSTAR engine was built by Hughes Electronics (now Boeing Satellite Systems).

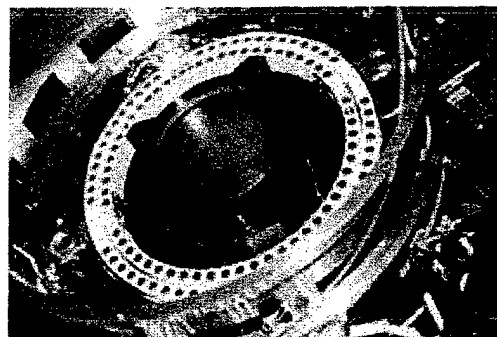

Figure 21: NSTAR Ion Engine Mounted on Deep Space 1

The successful demonstration of the NSTAR Ion thruster has provided future mission planners with an

off-the-shelf 2.3 kW ion thruster capable of processing about 100 kg of Xenon. The DAWN asteroid science mission has selected a spacecraft with three NSTAR engines. This will be the first NASA science mission to implement electric propulsion.

While the NSTAR thruster is appropriate in terms of power level and lifetime for Discovery Class missions, its application to larger missions such as outer solar system explorers and sample return missions is limited due to its power and total impulse capability.

Studies of the Europa Lander, the Saturn Ring Observer, and the Neptune Orbiter missions have identified a higher power, higher throughput, ~8 kW ion propulsion system as enabling. Studies of comet and Mars sample return missions as well as outer body orbiters such as Titan explorer have all shown the need for a higher power, higher total impulse thruster to minimize the propulsion system size, mass and complexity. NASA GRC was selected by the NASA Office of Space Science (Code S) to develop a next generation throttleable ~8 kW ion thruster capable of processing 400 kg of Xenon based on the lessons learned from NSTAR. This 40 cm thruster, dubbed NASA's Evolutionary Xenon Thruster (NEXT), is being developed by NASA GRC in conjunction with the Jet Propulsion Laboratory, Boeing Satellite Systems, and Aerojet.<sup>24</sup> Even at the 8 kW level, clustering of engines may be necessary to attain the total thrust and total impulse necessary. The next generation ion project will revisit the clustering work performed at NASA GRC in the 1980's.

The NASA Office of Space Science has also initiated efforts to develop a 6000 – 9000 s, >20kW ion engine system. This system is intended for nuclear electric missions to perform outer planetary exploration. The Jet Propulsion Lab's Nuclear Electric Xenon Ion Systems Technology (NEXIS) program is targeted at producing a 7500 s specific impulse ion thruster for operation at 20kW. The NEXIS grids will have a projected throughput life in excess of 1000 kg when fabricated from carbon-carbon materials. This translates to an operational life of 48000 hours. The NEXIS cathodes have projected life times well in excess of 50000 hours. A similar effort underway at NASA GRC is dubbed HiPEP. Both of these efforts are being supported by Aerojet RRC.

On the other end of the power spectrum, NASA mission studies have identified a need for

lightweight, low power, ion thruster technology for small spacecraft. An 8 cm diameter, 0.25 kW class thruster system was fabricated for testing and optimization. Performance goals include 50% efficiency at 0.25 kW input power. This represents a 2x increase in efficiency over SOA. Aerojet has performed a manufacturability study of the engine and identified many improvements that should lead to lower cost units. A second generation lightweight breadboard PPU has been fabricated and integrated with the engine. Combined with a newly discovered trajectory, small outer body orbiting spacecraft are enabled.

An alternative technology to Kaufman thrusters developed in the US is the Radiofrequency Ion Thruster invented by Prof. Loeb at Giessen University. This technology was industrialized by Astrium Space Infrastructure. Radio Frequency Ion thrusters ("RF" – Thrusters) are operated without any hot cathode ("main cathode") inside the thruster's ionization unit<sup>15</sup>. Instead, the propellant is ionized by electromagnetic fields. For this, the ionizer chamber, a vessel made of an isolating material, is surrounded by an rf-coil. The coil induces an axial magnetic field. The primary magnetic field induces a secondary circular electric field in which free electrons gain the energy for impact ionization.

After each impact ionization a xenon ion and at least one more free electrons are gained. Once the ionization process is triggered, a self-sustaining plasma-discharge is formed. The employed frequency is typically in the range of one megacycle.

Based on the success of the Artemis mission, Astrium is developing a new ion thruster for commercial application on the  $\alpha$ -Bus. This thruster, called RIT-22, is designed to deliver thrust levels ranging from less than 100 to above 200 mN at specific impulses up to 5000 sec. An engineering model, named RIT\_XT was tested over this performance range.<sup>29</sup>

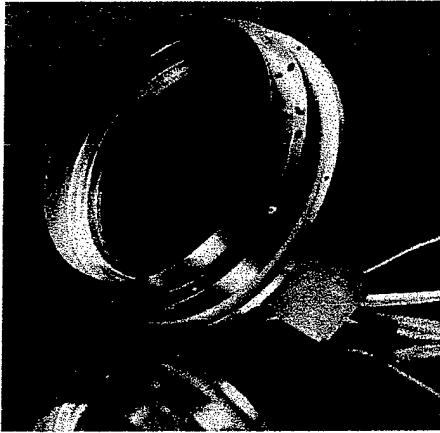

Figure 22: Astrium's RIT\_XT Development Model

In order to fulfill the needs of smaller satellites, an improved model of the flight proven RIT-10, the RIT-10\_EVO has been developed and is undergoing lifetesting.

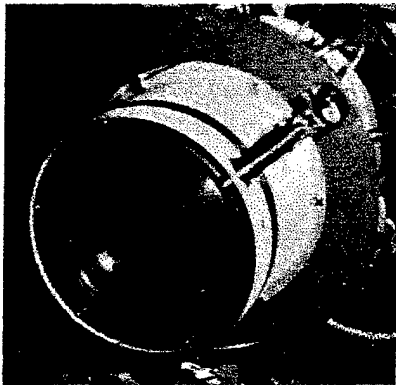

Figure 23: Astrium's RIT-10\_EVO

A second line of ion thrusters in Europe has been developed at QinetiQ in UK. Their T5 thruster will fly on ESA's GOCE (Gravity and Ocean Circulation Explorer) to compensate the air drag. A larger thruster, the T6, is under evaluation for ESA's deep space Bepi Colombo mission to Mercury.

In Italy, the RMT (Radiofrequency with Magnetic field ion Thruster), developed by LABEN/Proel, uses a RF, VHF plasma discharge in conjunction with a low level (about 100 Gauss) static magnetic field. Resonance phenomena in the plasma are exploited to enhance the ionization process in the low gas flow rate regime (corresponding to low thrust levels).

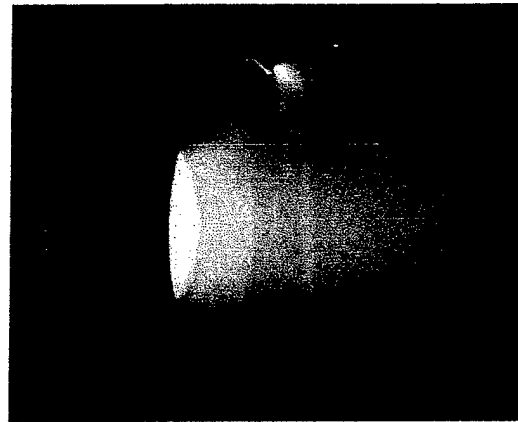

Figure 24: Laben's RMT in operation

The ion beam is extracted and accelerated through 3-grid ion optics. The RMT, whose engineering phase has been successfully completed under ASI contract, was conceived to provide a thrust level in the 2-12 mN range, with real time thrust throttling capability. The achievable specific impulse range, corresponding to the mentioned thrust range, is 2200-3600 sec.

The RMT thruster can be used in a variety of small (200 - 1000 kg) satellite missions:

- Drag compensation and control of LEO satellites at altitudes  $\leq 500$  km
- Orbital position control of LEO satellites belonging to a constellation or a formation
- Orbit raising from the launcher deployment orbit to the operational orbit (within the 300-500 km range)
- End-of-life orbit disposal
- Station keeping of GEO/MEO satellites

The RMT's real time thrust throttleability within the 2-12 mN range is achieved by varying the coil power, the RF power, and the xenon mass flow rate. The specific impulse can be adjusted by controlling the beam voltage and the propellant utilization efficiency.

#### 4.2.1.3 Colloid Thrusters

Colloid thrusters operate through the acceleration of charged liquid droplets by electrostatic grids and provide low level (1 to 100  $\mu\text{N}$ ) precisely controllable, low noise thrust generation.<sup>32,33,34,35</sup> As a result, the NASA Jet Propulsion Lab has identified them as a strong candidate to enable nanometer spacecraft position accuracy on future long baseline interferometric missions such as LISA. To demonstrate this capability, colloid thrusters will be

flown as part of the Disturbance Reduction System (DRS) payload on the SMART 2 spacecraft.

The colloid thrusters for this mission are being developed by the Busek Co.<sup>25</sup> Busek is delivering eight colloid thruster systems grouped in two clusters. A typical thruster is shown in Figure 25. Each of the colloid thrusters will deliver adjustable thrust in the range of 2 to 20  $\mu\text{N}$  with 0.1  $\mu\text{N}$  resolution and adjustability. The colloid thruster will be neutralized using a propellantless carbon nanotube field emission cathode developed by Busek.<sup>36,37</sup> This is the first flight demonstration of a field emitter array cathode for electric propulsion device neutralization, an advance which may serve to eliminate the need to carry propellant for thruster neutralization.

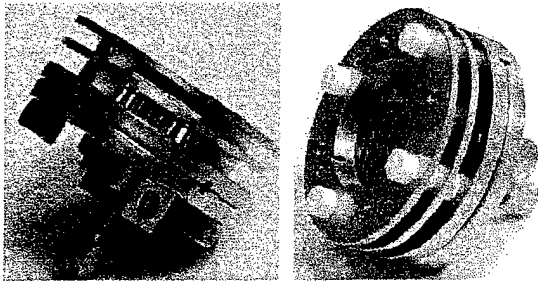

Figure 25: Colloid Thruster for the SMART 2 DRS Mission

Busek's colloid development effort is being supported by modeling and simulation work under way at MIT under AFOSR sponsorship.<sup>27</sup> This model will examine colloid thruster plume issues. Separate work is underway at MIT to develop microfabricated colloid thrusters and, in collaboration with Yale University, to characterize the basic physics of various regimes of colloid thruster operation.

#### 4.2.1.4 FEEP Technology

For very low thrust and high specific impulse applications in Europe, the Field Effect Electric Propulsion (FEEP) technology is being developed. Applications include the fine control of distances of satellites in a formation for interferometry missions. FEEP thrusters are able to deliver thrust levels between 1  $\mu\text{N}$  and about 1 mN at a specific impulses higher than 6000 sec.

In Austria, ARC Seibersdorf Research continues the development of the indium FEEP (InFEEP) technology. Recent development efforts have

concentrated on the longest endurance test campaign for this type of thruster, reaching 3800 hours of continuous firing at thrust levels between 1-55  $\mu\text{N}$ . Direct thrust measurements at ONERA and NASA JPL confirmed performance predictions based on electrical parameters. Additionally, thrust noise measurements were done at NASA JPL and NASA GSFC at frequencies up to 100 Hz. Based on these successful tests, Astrium and ESA selected the InFEEP technology for an advanced phase C/D of the microthruster assembly on ESA's GOCE satellite. ARC Seibersdorf Research, together with its industrial partners MAGNA Steyr, Austrian Aerospace, Jonneum Research, and Astrium is currently preparing a complete microthruster package, including flight electronics, for qualification testing in early 2004. New configurations are also currently under development such as the InFEEP-1000 thruster with a thrust range of 1-1000  $\mu\text{N}$ .

#### 4.2.2 Electromagnetic

##### 4.2.2.1 Pulsed Plasma Thrusters

Pulsed plasma thrusters (PPTs) utilize pulsed electric arcs to ionize propellant which is then accelerated via the interaction of the ions with the electric field of the arc and a self-generated magnetic field. Most PPTs utilize solid propellant and provide over 1000 s of specific impulse while operating at average power levels between 1 – 200 W. PPT systems offer excellent fuel economy and fit the power range available to many small, power limited spacecraft. Unlike steady state devices, the pulsed nature of the PPT system allows power throttling over a wide range without loss in performance simply by adjusting the pulse repetition rate. Very small impulse bits can be attained for precision pointing applications. The use of a solid, inert polymer, typically Teflon™, as propellant results in a very simple, lightweight, low-cost, modular propulsion system that eliminates the need for toxic propellants and costly, complicated propellant distribution systems.

These unique attributes of the PPT make them enabling for NASA science missions that include precision control of deep space interferometers and primary propulsion for NASA micro-science spacecraft. To meet this need, NASA GRC<sup>23</sup> has implemented a program for advanced pulsed plasma thruster development. The first phase of this effort involved developing a commercial source for Teflon™ PPTs with specific impulses greater than 1100 s and efficiencies over 10% at power levels of 50W. Under funding from NASA GRC, Aerojet

RRC<sup>24</sup> developed a PPT for demonstration on the NASA Goddard Space Flight Center Earth Observing-1 (EO-1) spacecraft (see Figure 26). This thruster was built on the design baseline of the 1970's LES 8/9 PPT from Lincoln Laboratories. The LES 8/9 PPT was taken to a very high level of maturity, but never flown. Aerojet implemented design improvements, resulting in a lighter, more volume efficient package, and a slight improvement in the overall energy conversion efficiency

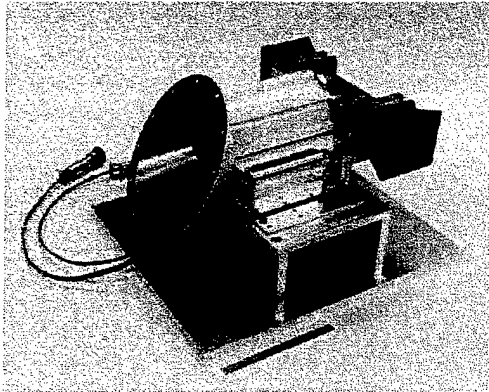

Figure 26: Aerojet PPT for EO-1 spacecraft

Current NASA work is aimed at developing the component technology required for operational sparse aperture Space-Based Interferometers that will require extreme position control. To achieve this goal, technology advances must be made in mass and life of the energy storage and discharge electronics. In addition, spacecraft integration concerns, including plume emission spectra, electromagnetic compatibility, and optics contamination are being addressed. Work being performed at Worcester Polytechnic Institute<sup>38</sup> to develop and validate an advanced hybrid (particle/fluid) computational PPT plume model is intended to address these contamination concerns.

AFRL/PR is developing a simple, miniaturized pulsed plasma thruster or micro-PPT to provide propulsion for small and micro satellite applications. The micro-PPT, shown in Figure 27, was invented at AFRL in 1997 and has undergone subsequent improvements and maturation through collaborations with their partners and WE Research<sup>39</sup> and the Busek Co.<sup>25</sup> It has also been supported by modeling and simulation work performed at the University of Michigan. This modeling work has been validated through work performed by University of Illinois researchers.

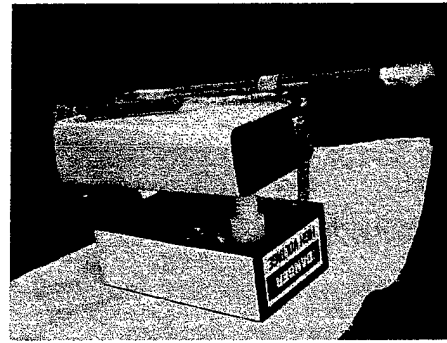

Figure 27: Air Force Research Laboratory Micro Pulsed Plasma Thruster

The MicroPPT is in advanced development at Busek and will be used to demonstrate three-axis attitude control on a microsat mission. The use of propulsive attitude control can decrease the required subsystem mass on 25-50 kg class satellites dramatically, while enabling the use of the same hardware for primary propulsion. Figure 28 shows a picture of the engineering model three-axis design. Current performance estimates of this design are in excess of 5  $\mu\text{N/W}$ , and more performance mapping will be conducted over summer 2003.

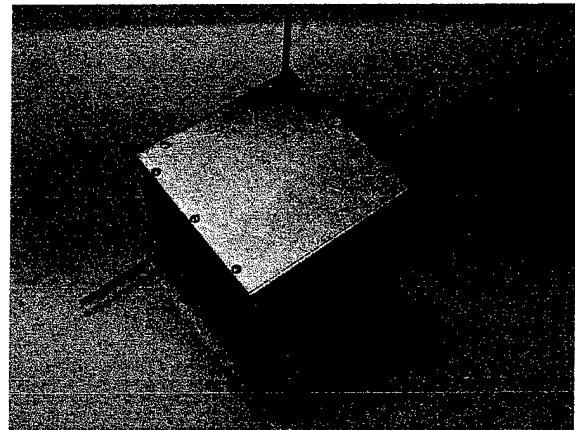

Figure 28: Engineering Model Three-Axis MicroPPT Propulsive Attitude Control System

CU Aerospace and the University of Illinois have a long history of PPT development efforts. Recent work has raised the performance of their 100 W coaxial PPT-11 to the 1400 s, 15% efficiency level.<sup>40</sup>

In a new line of research and development initiated at the Institut für Raumfahrtssysteme (IRS) of the University of Stuttgart, a large pulsed 20-GW coaxial plasma accelerator for industrial processing has been designed and is in the process of being assembled. In parallel, to make maximum use of synergies, pulsed electric propulsion systems based on that same

plasma acceleration scheme are also being theoretically and experimentally investigated at IRS. These high power PPTs are of particular interest for space propulsion and exploitation since they combine the advantages of continuously operated high-power magnetoplasmadynamic (MPD) thrusters (significantly reduced propellant consumption through high exhaust velocities resulting in an increased payload fraction) with low, variable average electric power consumption and manageable heat generation. This available-power capacity combined with their ability to deliver small impulse bits for orbit and attitude maintenance makes them especially well suited for small satellites and/or constellations of satellites where precise orientation-keeping is mandatory for mission success. Currently at IRS, several projects using micro-satellites with PPT-based primary or secondary propulsion are under investigation, including a scientific observer in a polar orbit around the moon.

#### 4.2.2.2 Vacuum Arc Thrusters

Alameda Applied Sciences Corp.<sup>41</sup> (AASC) has developed the Vacuum Arc Thruster (VAT) to utilize the characteristics of a vacuum arc for space propulsion. The vacuum arc is a diffuse plasma arc discharge that takes place between two metallic electrodes in vacuum. It provides a simple and straightforward way of producing plasmas from the cathode material with a density from  $10^{11}$  to  $10^{16}$  cm<sup>-3</sup> and temperatures of several eV. The VAT has been extensively tested and thrust measurements have been performed at the Jet Propulsion Laboratory and Lawrence Berkley National Lab. It has demonstrated a thrust/power of approximately  $10\mu\text{N/W}$  over a range of 0 – 10 W and specific impulses ranging from 1000 – 3000 s, dependent on material. Collaborations are underway between AASC and both the University of Illinois Urbana-Champaign and Michigan Technological University<sup>28</sup> to supply VATs for nanosatellites propulsion. AASC is developing new propulsion concepts based on the VAT to enable it to perform a wider range of missions.

#### 4.2.2.3 Magnetoplasmadynamic Thrusters

For several decades, extensive investigations have been carried out at IRS of the University of Stuttgart on self-field magnetoplasmadynamic (MPD) thrusters in the high power range from 100 kW up to 1 MW, initially supported by USAF grants<sup>30</sup>. These electric thrusters offer high thrust densities at fairly high specific impulse levels and, therefore, are

considered good candidates for manned and unmanned interplanetary missions and for orbit transfer. Since all are operated in steady state mode and, in general, testing time does not limited by thruster life, run times of several hours can easily be achieved.<sup>30,42</sup> IRS is currently the only facility in Europe, which operates high power MPD thrusters in steady state mode. The experimental work has been accompanied by the development of numerical codes, allowing for theoretical calculations of MPD thrusters and a comparison with experimental data now under funding of the German Science foundation DFG and the German Space Agency DARA (now part of the DLR).<sup>30,43,44</sup> To compare to numerical computations, extensive plasma diagnostics with emission spectroscopy and electro-static probes as well as investigations of the temperature distribution on the cathode surface have been performed, again under funding of the DFG.

Different geometries are under investigation at IRS. Thruster versions with a cylindrical geometry providing an almost pure magnetic acceleration of the propellant were investigated at power levels up to 350 kW and currents up to 15 kA. Although different propellants have been used, the most complete data sets are available for argon.<sup>42,45</sup> The nozzle-type thrusters combine the thermal expansion of pure arcjets with the magnetic acceleration of pure MPD-thrusters. Thrust values of 27 N at electrical power levels up to 800 kW, current levels up to 8000 A, and thrust efficiencies up to 27 % were obtained. So far specific impulse is limited to < 1500s due to plasma instabilities with this specific geometry. Extensive numerical and experimental investigations of these instabilities have been performed.<sup>46,47</sup> Thruster designs with radiation-cooled and water-cooled anodes are currently under experimental and numerical investigation.

NASA GRC<sup>23</sup> is building on its past efforts in the area of high-power MPD thrusters. The MPD was an outgrowth of NASA GRC and Air Force efforts in high power arcjets in the 1960's. During the 60's and early 1970's, under NASA and AFOSR support, 30 kW-class MPDs operating on various propellants including hydrogen and lithium showed promising performance. With the exception of efforts at US academic institutions, MPD research in the US ceased until the late 1980's when it was reinvigorated under NASA's Space Exploration Initiative. JPL continues to work on leveraging past Russian investments in lithium MPDs and is pursuing original work with condensable fueled MPDs. Princeton University is an academic partner in that effort. NASA GRC has concentrated on gas-fueled engines

ranging from 0.1 MW - 10 MW. Domestic numerical design capability has been refined and designs for both a 0.1 - 1 MW steady-state breadboard engine and a 1 - 10 MW pulsed engine have been completed, the engines built, and testing initiated.

#### 4.2.2.4 Pulsed Inductive Thrusters

The pulsed inductive thruster (PIT) is a high power electromagnetic propulsion system that can provide high thrust efficiency over a wide range of thrust and specific impulse values. There should be minimal erosion due to the electrode-less nature of the discharge. This device has been under investigation at NGST<sup>2</sup> for more than two decades. The development-engineering model Mark V is shown in Figure 29. Single-shot experiments demonstrated specific impulse values between 2000 and 8000 s, with thruster efficiencies exceeding 50% using ammonia propellant. The power level of this thruster can range from a few kilowatts to more than a megawatt. In collaboration with NGST, NASA GRC<sup>23</sup> has initiated an effort to seek an understanding of the physics and engineering behind this potentially versatile thruster.

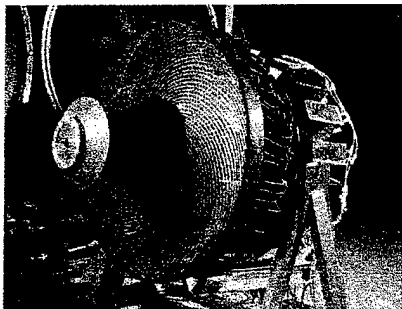

Figure 29: Mark V Pulsed Inductive Thruster

#### 4.2.2.5 VASIMR

The NASA Johnson Space Center<sup>23</sup> is developing the advanced Variable Specific Impulse Magnetoplasma-dynamic Rocket (VASIMR) concept under the direction of Dr. Franklin Chang-Diaz. The VASIMR system is a high power, plasma rocket that is capable of exhaust modulation at constant power. It consists of three major magnetic cells: "forward," "central," and "aft," where plasma is respectively injected, heated, and expanded through a magnetic nozzle. The forward cell handles the main injection of propellant gas and the ionization subsystem; the central cell acts as an amplifier to further heat the plasma to the desired magnetic nozzle input conditions. The aft cell is a hybrid two-stage

magnetic nozzle that converts the thermal energy of the fluid into directed flow, while protecting the nozzle walls and ensuring efficient plasma detachment from the magnetic field. During VASIMR operation, neutral gas is injected at the forward cell and ionized. The resulting plasma is heated with RF energy in the central cell to the desired temperature and density, by the process of ion cyclotron resonance. After heating, the plasma is magnetically (and gas-dynamically) exhausted at the aft cell to provide modulated thrust.

#### 4.2.3 Electrothermal

##### 4.2.3.1 Arcjets

In addition to these hydrazine arcjets on commercial spacecraft, the 30 kW ESEX ammonia arcjet system (Figure 30) set a record for the highest powered EP device ever flown on a spacecraft. It was launched in 1999 as part of the U.S. Air Force experimental ARGOS spacecraft, demonstrating reliable PCU and thruster operation even at these high power levels. A key result of the ESEX experiment was the demonstration of communications and data transmission in the vicinity of the arcjet plume without perceptible interference. The arcjet system also operated through multiple start transients and steady state firings without integration concerns observed on any on-board spacecraft system.

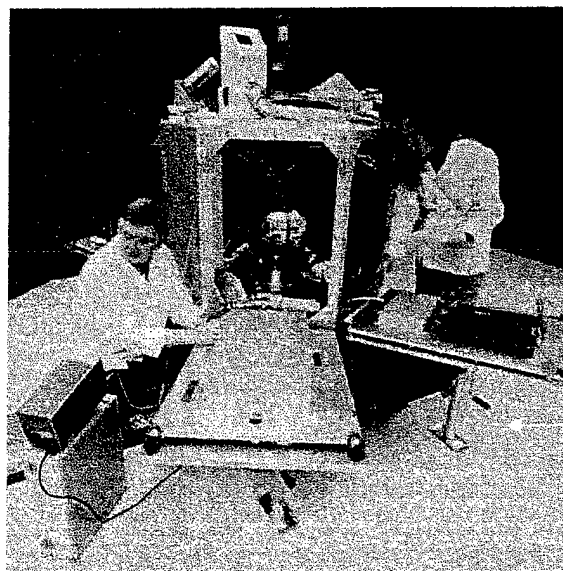

Figure 30: The 30 kW ESEX ammonia arcjet system is the highest power EP system ever flown

At IRS there has been significant development of thermal arcjet thrusters over the past 15 years. IRS is

currently the only facility in Europe to pursue arcjet thruster research. This development is divided into three lines: low power arcjets from 0.7 to 2 kW, medium power arcjets, power class at 10 kW, and high power arcjets from 50 to 100 kW.

The low power arcjets, with ammonia or hydrazine propellants, are aimed for position control and acquisition for spacecraft in the 1000 kg class. An ammonia thruster (750 W) was deployed on the AMSAT Oscar 40 satellite. Hydrazine thrusters (1 kW) were a cooperative effort with DASA (now Astrium). Specific impulses over 600 s were reached with ammonia.

The medium power arcjet line was started by an ESA contract, and later sponsored by BMDO (now MDA). The main propellant is hydrogen, with a goal to optimize the thermal management of the anode/nozzle by regenerative cooling. Specific impulses about 1300 s at efficiencies > 40 % were achieved.

The high power line was started with the SDIO in the frame of the SP-100 nuclear reactor program. The goal was to establish steady state arcjet operation with several hours of lifetime. With a radiation cooled version and hydrogen as propellant, an  $I_{sp}$  over 2000 s at 100 kW was obtained. These encouraging results make these high power thermal arcjet thrusters strong candidates for future NEP scenarios such as piloted Mars missions. A further development of these thrusters will eventually take place in collaboration with NASA GRC.

New research to augment  $I_{sp}$  as well as efficiency has been started with a hybrid concept that uses inductive heating as a second stage of a conventional arcjet.

To support and understand the development of thermal arcjets, efforts were made, with the sponsorship of first AFOSR and later the German Research Foundation DFG, to develop numerical codes especially for high power applications. Good agreement with experiments was demonstrated.

#### 4.2.3.2 Laser Plasma Thrusters

Photonic Associates<sup>48</sup> has developed the Micro Laser Plasma Thruster ( $\mu$ LPT), based on laser ablation of a solid fuel. In its present state of development, the laser is an infrared diode laser, the fuel format is a tape, and transmission or "T-mode" illumination is employed. This thruster has demonstrated thrust in excess of 75  $\mu$ N for microsat applications.

### 4.3 Solar Thermal Propulsion

Solar Thermal Propulsion (STP) converts concentrated solar energy into thermal energy. This thermal energy is used to expand propellant out of a conventional nozzle. Since the thermal energy does not come from combustion, lightweight propellants like hydrogen, ammonia, or methane can be used and no oxidizer is necessary. A solar thermal system using cryogenic hydrogen will give 800 to 1000 s specific impulse at 4.5 N of thrust while a storable ammonia system will give about 550 s. The STP propulsion system consists of a thruster, a concentrator subsystem, a pointing and tracking subsystem, and a propellant tank/management system. All of these subsystems must be lightweight and take very little volume before deployment. SRS Technologies,<sup>49</sup> ATK Thiokol Propulsion,<sup>50</sup> Boeing,<sup>51</sup> NASA Marshall Space Flight Center and AFRL/PR<sup>52</sup> are all working this technology. This team of government and industry has made significant advancements in many of the STP subsystems over the last few years including: inflation control system, 3-D dynamic focus control system, sun sensors for focus control, and subscale integrated concentrator systems.

Inflatable concentrator technology is being pursued since it packages into an inexpensive, very small mass/volume before deployment and yet can expand into very large concentrating reflectors. Ways to rigidize inflatable concentrators once deployed are being investigated; inflation-stressed thin films or membranes make very smooth and efficient reflective surfaces. The concentrator is made of a castable, colorless polyimide membrane. This thin membrane is easily stowed in the launch vehicle and deployed on orbit. This technology has been tested under both ambient and various simulated space environments.

Current efforts are focused on fabricating a 4m x 6m off-axis parabolic torus supported concentrator attached to the vehicle using advanced lightweight composite struts. The concentrator system is a complex design that takes into account the energy delivery requirements, spacecraft pointing accuracy, characteristics of the reflective coating material, environmental effects on concentrator shape quality, and overall system optical performance. The most recent test series, conducted in July 2002, demonstrated a 6 degree of freedom (DoF) sun tracking, and fine focus control system under ambient conditions. This test answered key concerns about the system's ability to control the concentrators accurately in order to acquire, track, and focus the

sun within the acceptable tolerances for achieving predicted thermal performance.

The concentrator will be integrated with a direct gain solar engine comprised of a molybdenum hyperbolic secondary concentrator, and a tungsten/rhenium absorber. This integrated ground test is scheduled for the second quarter of 2003. The next logical step in the evolution of this STP concept is to perform prototype and/or subsystem level flight experiments to demonstrate operational performance of the various key technologies.

STP technology allows long-term storage of stages in orbits up to GEO with tremendous maneuvering capability. Servicing of low-Earth orbit (LEO) and GEO assets and reusable orbit transfer vehicles (ROTVs) are other possible applications. Offering a combination of high specific impulse and high thrust/weight together with thrust levels from 10 to 100 lb or more, a large-scale STP offers a low-cost alternative to nuclear thermal or solar electric stages.

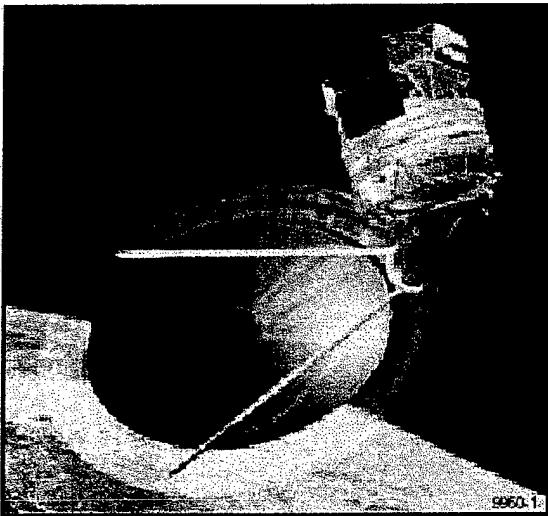

Figure 31: Artist's Concept of a Solar Thermal Demonstration

## 5 Summary

A wide range of propulsion technologies are under development in the US and Europe to provide solutions to meet a gamut of mission needs. Work continues to improve the performance, storability, and environmental friendliness of liquid monopropellant, bipropellant, cold gas, and gel systems for orbital insertion, stationkeeping, orbital maneuvering, and attitude control. Electric propulsion technologies have established operability

for stationkeeping and orbital insertion and are being baselined for next generation scientific deep space and interferometry missions. Research efforts are now concentrated primarily on expanding the applicable power range for electric propulsion systems in order to enable large orbit transfer vehicle applications and micro/nano spacecraft propulsion systems. Solar thermal propulsion systems provide an excellent mix of high specific impulse and high thrust for orbit transfer missions. The thrusters discussed in this paper are summarized in Table 3. Not all parameters were provided for each thruster. Power levels are not applicable (N/A) for chemical and solar thermal thrusters.

Table 3: Thrusters Discussed in This Paper

Developer	Thruster	Thrust	Power	Specific Impulse	Page
Aerojet	HiPAT Bipropellant	445 N	N/A	-	5
Aerojet	Monopropellant Thruster	1 N	N/A	-	7
Aerojet	Monopropellant Thruster	20 N	N/A	-	7
Aerojet	Non-Toxic Monopropellant	-	N/A	-	7
Aerojet	MR-501 EHT Resistojet	-	-	300 s	8
Aerojet	MR-502 EHT Resistojet	-	-	300 s	8
Aerojet	MR-510 Arcjet	-	2 kW	600 s	9
Aerojet	MSAT Hall Thruster	-	50 kW	-	12
Aerojet	BPT-4000 Hall Thruster	-	4.5 kW	-	13
Aerojet	EO-1 Pulsed Plasma Thruster	-	50 W (Avg.)	1100 s	18
Air Force Research Lab	micro-Pulsed Plasma Thruster	5 $\mu$ N/W	-	-	19
Air Force Research Lab	ESEX Arcjet	-	30 kW	-	21
Alameda Applied Sciences Corp.	Vacuum Arc Thruster	10 $\mu$ N/W	1 - 10 W	1000 - 3000 s	20
ARC Seibesdorf	InFEFP	1 - 55 $\mu$ N	-	> 6000 s	18
ARC Seibesdorf	InFEFP-1000	1 - 1000 $\mu$ N	-	> 6000 s	18
Astrium	UFP Main Thruster Bipropellant	400 N	N/A	-	4
Astrium	Platinum 10 N RCS Bipropellant	10 N	N/A	-	4
Astrium	Platinum 22 N RCS Bipropellant	22 N	N/A	-	4
Astrium	C/SiC LAE Bipropellant	400 N	N/A	>325 s	5
Astrium	RIT-10 Ion Engine	-	-	3420 s	9
Astrium	ROS 2000 Hall Thruster	-	-	-	15
Astrium	RIT-22 Ion Engine	100 - 200 mN	-	< 5000 s	16
Astrium	RIT-10 EVO Ion Engine	-	-	-	17
Atlantic Research Corporation	Next-Generation Bipropellant	22 N	N/A	300 s	6
Boeing	13 cm XIPS Ion Engine	18 mN	500 W	2568 s	9
Boeing	25 cm XIPS Ion Engine	165 mN	4.5 kW	3800 s	9
Boeing	NSTAR Ion Engine	-	2.3 kW	-	15
Busek	BHT-200 Hall Thruster	-	200 W	1350 s	13
Busek	600 W Hall Thruster	-	600 W	-	13
Busek	BHT-8000 Hall Thruster	-	8 kW	1200 - 3500 s	13
Busek	Colloid Thruster	2 - 20 $\mu$ N	-	-	18
CNES	HAN Based Monopropellant	-	N/A	-	11
CU Aerospace	PPT-11	-	100 W (Avg.)	1400 s	19
Fakel	SPT-100 Hall Thruster	-	-	-	10
IRS (Univ. of Stuttgart)	20 GW PPT	-	20 GW	-	19
IRS (Univ. of Stuttgart)	Cylindrical Magnetoplasmadynamic Thruster	-	350 kW	-	20
IRS (Univ. of Stuttgart)	Nozzle Magnetoplasmadynamic Thruster	27 N	800 kW	-	20
IRS (Univ. of Stuttgart)	Low Power Arcjet	-	0.7 - 2 kW	600 s	22
IRS (Univ. of Stuttgart)	Mid Power Arcjet	-	10 kW	1300 s	22
IRS (Univ. of Stuttgart)	High Power Arcjet	-	50 - 100 kW	2000 s	22
LABEL/Proel	RMT Ion Engine	2 - 12 mN	-	2200 - 3600 s	17
Michigan Tech University	Bismuth Hall Thruster	-	-	-	14
NASA GRC	50 kW Hall Thruster	-	9 - 72 kW	-	12
NASA GRC	NEXT Ion Engine	-	8 kW	-	16
NASA GRC	HiPEP Ion Engine	-	> 20 kW	6000 - 9000 s	16
NASA GRC	8 cm Ion Engine	-	250 W	-	16
NASA GRC	Steady State Magnetoplasmadynamic Thruster	-	0.1 - 1 MW	-	21
NASA GRC	Pulsed Magnetoplasmadynamic Thruster	-	1 - 10 MW	-	21
NASA JPL	NEXIS Ion Engine	-	> 20 kW	7500 s	16
NASA JSC	VASIMR	-	-	-	21
Northrop Grumman Space Technology	Non-Toxic RCS Bipropellant	4450 N/111 N	N/A	-	6
Northrop Grumman Space Technology	Gel Propellants	-	N/A	-	11
Northrop Grumman Space Technology	Mark V Pulsed Inductive Thruster	-	kW - MW	2000 - 8000 s	21
Penn State University	Microthrusters	-	N/A	-	8
Photonic Associates	micro-Laser Plasma Thruster	75 $\mu$ N	-	-	22
Pratt & Whitney	T-220-HT Hall Thruster	> 1 N	2 - 22 kW	-	14
Purdue University	Hydrogen Peroxide Bipropellants	-	N/A	-	6
Purdue University	LOX/Hydrocarbon Bipropellants	-	N/A	-	6
QinetiQ	T5 Ion Engine	-	-	-	17
QinetiQ	T6 Ion Engine	-	-	-	17
Snecma	PPSX000 Hall Thruster	340 mN	5 - 6 kW	2480 s	14
Snecma	2 Stage Hall Thruster	-	-	-	15
SpaceDev	Plexiglass/Nitrous Oxide Hybrid	-	N/A	-	12
SRS Technology	Solar Thermal Thruster	4.5 N	N/A	800 - 1000 s	22
Surrey Space Technology	Butane Microthruster	-	N/A	-	11
Surrey Space Technology	Resistojet	-	15 W	-	11
Surrey Space Technology	Nitrous Oxide Monopropellant	-	N/A	-	11
Surrey Space Technology	Hydrogen Peroxide/Kerosene Bipropellant	-	N/A	-	11
Swedish Space Corporation	ADN Monopropellant	-	N/A	-	11
Thales Aerospace	HEMP Hall Thruster	-	600 W	1680 s	15
TNO-PML	HNF Monopropellant	-	N/A	-	11
VACCO	ChEMS Cold Gas	50 mN/75 mN	N/A	-	8

## ACKNOWLEDGEMENTS

The authors would like to thank their colleagues in government, industry, and academia for the time and effort that they invested in preparing their submissions for this review.

## REFERENCES

- <sup>1</sup> Morgan, O., "Monopropellant Rocket Engines for In-Space Propulsion," Aerojet Corporate Communication to Dr. Frank Gulczinski, 14 March 2003.
- <sup>2</sup> Papesh, C., "Rocket Propulsion Development Summary," Northrop Grumman Space Technology Corporate Communication to Dr. Frank Gulczinski, 12 February 2003.
- <sup>3</sup> Clauss, C., Atlantic Research Corporation Communication to Dr. Frank Gulczinski, 13 February 2003.
- <sup>4</sup> Heister, S. et al., "Space Propulsion Research at Purdue University," University Communication to Dr. Frank Gulczinski, 29 January 2003.
- <sup>5</sup> Morgan, O., "Bipropellant Rocket Engines for In-Space Propulsion," Aerojet Corporate Communication to Dr. Frank Gulczinski, 14 March 2003.
- <sup>6</sup> Yetter, R.A., et al., "Development of Meso and Micro Scale Liquid Propellant Thrusters," AIAA Paper 2003-0676, January 2003.
- <sup>7</sup> Cardin, J., "MEPSI Micro-Propulsion System Overview," VACCO Corporate Communication to Dr. Frank Gulczinski, 7 February 2003.
- <sup>8</sup> Boeing Xenon Ion Propulsion Web Site: <http://www.boeing.com/defense-space/space/bss/factsheets/xips/xips.html>.
- <sup>9</sup> Oleson, S., "Electric Propulsion," *Aerospace America*, Vol. 40, No. 12, pp. 58-59, December 2002.
- <sup>10</sup> Lysik, M., Jacod, V., "Electric Propulsion on @Bus platform", IEPC 03-170
- <sup>11</sup> Killinger, R., Bassner, H., Leiter, H., Kukies, R., "RITA Ion Propulsion for ARTEMIS - Results Close to the Completion of the Life Test, AIAA-2001-3490
- <sup>12</sup> Killinger, R., Kukies, R., Surauer, M., van Holtz, L., Tomasetto, A., "ARTEMIS Orbit Raising Inflight Experience with Ion Propulsion", IAC-02-S.4.04
- <sup>13</sup> Killinger, R., Bassner, H., Müller, J., "Development of an High Performance RF-Ion Thruster", AIAA 99-3445
- <sup>14</sup> Killinger, R., Bassner, H., Kienlein, G., Müller, J., "Electric Propulsion System RITA for ARTEMIS", AIAA 99-2271
- <sup>15</sup> Bassner, H., Killinger, R., Leiter, H., Müller, J., "Advantages and Applications of the RF-Ion Thruster RIT", AIAA 2001-3494
- <sup>16</sup> Killinger, R., Bassner, H., Kienlein, G., Müller, J., "Electric Propulsion System for ARTEMIS", IEPC 99-054
- <sup>17</sup> Lysik, M., Jacod, V., "Electric Propulsion on @Bus platform", IEPC 03-170
- <sup>18</sup> V. Zakirow et al., Surrey Space Centre, University of Surrey, UK, "Nitrous Oxide as a Rocket Propellant", IAF-00-S.2.07, Oct. 2002
- <sup>19</sup> D. Gibbon, Surrey Satellite Technology Ltd, Communication to Astrium, 3 April 2003
- <sup>20</sup> A. Cadiou, CNES, Communication to Astrium, 10 April 2003
- <sup>21</sup> K. Anflo et al. SSC, M. Johansson, Swedish Defence Research Agency, R. Nedar, Volvo Aero, "Towards Green Propulsion for Spacecraft with AND-Based Monopropellants", AIAA paper 2002-3847
- <sup>22</sup> M. Fick et al., Astrium GmbH, J.L.P.A. Moerel, TNO-PML, W.H.M. Welland-Veltmans, APP, The Netherlands, "Industrial Benefits of Applying HNF in Monopropellant Satellite Propulsion" ESA 4th Green Propulsion Conference
- <sup>23</sup> Dunning, J., and Benson, S., "NASA's Electric Propulsion Program," AIAA Paper 2002-3557, July 2002.
- <sup>24</sup> Cassady, J., "History of Electric Propulsion at Aerojet, Redmond Operations," Aerojet Corporate Communication to Dr. Frank Gulczinski, 24 February 2003.
- <sup>25</sup> Hruby, V., "Busek's EP Programs," Busek Corporate Communication to Dr. Frank Gulczinski, 20 February 2003.
- <sup>26</sup> McVey, J., Pratt & Whitney Space Propulsion Corporate Communication to Dr. Frank Gulczinski, 13 February 2003.
- <sup>27</sup> Martinez-Sanchez, M., MIT University Communication to Dr. Frank Gulczinski, 17 February 2003.
- <sup>28</sup> King, L., Michigan Technological University Communication to Dr. Frank Gulczinski, 24 January 2003.
- <sup>29</sup> Leiter, H., Killinger, R., Bassner, H., Müller, J., Kukies, R., Fröhlich, T., "Evaluation of the performance of the advanced 200mN radio frequency ion thruster RIT-XT", AIAA 2002-3836
- <sup>30</sup> Monika Auweter-Kurtz, *Plasma thruster development program at the IRS*, Acta Astronautica, Vol. 32(5): pp. 377-391, 1994.

- <sup>31</sup> Katz, I., "Electric Propulsion at the Jet Propulsion Laboratory," NASA JPL Communication to Dr. Frank Gulczinski, 21 February 2003.
- <sup>32</sup> Gamero-Castaño, M, Hraby, V., "Electrospray as a Source of Nanoparticles for Efficient Colloid Thrusters," Journal of Propulsion and Power, 17, 977, 2001.
- <sup>33</sup> Gamero-Castaño, M., Hraby, V., "Electric Measurements of the Charged Sprays Emitted by Cone-Jets," Journal of Fluid Mechanics, 459, 245, 2002.
- <sup>34</sup> Gamero-Castaño, M., "Electric -Field-Induced Ion Evaporation from Dielectric Liquid," Physical Review Letters, 89, 14, 30 September 2002.
- <sup>35</sup> Hraby, V., et al, "Micro Newton Colloid Thruster System Development," IEPC Paper 01-281, October 2001.
- <sup>36</sup> Gamero-Castaño, M., et al., "Electron Field Emission From Carbon Nanotubes, and it's Relevance in Space Applications," AIAA Paper 2000-3263, July 2000.
- <sup>37</sup> Hraby, V., et al, "Modeling of Field Emission Cathodes for Space Propulsion," AIAA Paper 2002-2121, May 2002.
- <sup>38</sup> Gatsonis, N., Worcester Polytechnic University Communication to Dr. Frank Gulczinski, 18 February 2003.
- <sup>39</sup> Bushman, S., WE Research Corporate Communication, 19 February 2003.
- <sup>40</sup> Jaeger, S. C., et al., "Optimization of Performance and Efficiency of a Coaxial Pulsed Plasma Thruster," AIAA Paper 2002-3977, 2002.
- <sup>41</sup> Schein, J., "Vacuum Arc Thruster," Alameda Applied Sciences Corporate Communication to Dr. Frank Gulczinski, 13 February 2003.
- <sup>42</sup> Th. Wegmann, *Experimentelle Untersuchung kontinuierlich betriebener magnetoplasmadynamischer Eigenfeldtriebwerke*, Dissertation, Fakultät Luft- und Raumfahrttechnik, Universität Stuttgart, 1994.
- <sup>43</sup> Christian Boie, *Numerische Simulation magnetoplasmadynamischer Eigenfeldtriebwerke mit hochauflösenden adaptiven Verfahren*, Dissertation, Fakultät Luft- und Raumfahrttechnik, Universität Stuttgart, 2000.
- <sup>44</sup> Jörg Heiermann, *A finite volume method for the solution of magnetoplasmadynamic conservation equations*, Dissertation, Fakultät Luft- und Raumfahrttechnik, Universität Stuttgart, 2002.
- <sup>45</sup> Auweter-Kurtz, M., Boie, C., Habiger, H., Kaeppler, H.J., Kurtz, H.L., Sleziona, P.C., Wegmann, T., Winter, M.W.: *Numerische Simulation von MPD-Triebwerken und Vergleich mit durchzuführenden experimentellen Untersuchungen*, Final Report of the DFG Research Project Au85/5-2, Institut für Raumfahrtsysteme, Universität Stuttgart, 1998.
- <sup>46</sup> Herbert O. Schrade, Thomas Wegmann and Thomas Rösger, *The onset phenomena explained by run-away joule heating*, IEPC 91-022, AIDAA/AIAA/DGLR/JSASS 22nd International Electric Propulsion Conference, October 14-17, 1991 / Viareggio, Italy.
- <sup>47</sup> Henri Wagner, Theoretical Investigation of Drift- and Gradient-Driven Instabilities in MPD Thruster Flows, Dissertation, Fakultät Luft- und Raumfahrttechnik, Universität Stuttgart, 1994.
- <sup>48</sup> Phipps, C. and Luke, J., "Micro Laser Plasma Thruster," Photonic Associates Corporate Communication to Dr. Frank Gulczinski, 20 January 2003.
- <sup>49</sup> Geirow, P., "Status of Solar Thermal Propulsion Technology Developments," SRS Technologies Corporate Communication to Dr. Frank Gulczinski, 14 February 2003.
- <sup>50</sup> Lester, D., ATK Thiokol Corporate Communication to Dr. Frank Gulczinski, 14 February 2003.
- <sup>51</sup> Kessler, T., Frye, P., and Partch, R., "Solar Thermal OTV - Applications to Reusable and Expandable Launch Vehicles," IAF Paper 99-V.2.04, October 1999.
- <sup>52</sup> Holmes, M., AFRL Communication to Dr. Frank Gulczinski, 17 February 2003.