

# REPORT DOCUMENTATION PAGE

Form Approved  
OMB No. 0704-0188

Public reporting burden for this collection of information is estimated to average 1 hour per response, including the time for reviewing instructions, searching existing data sources, gathering and maintaining the data needed, and completing and reviewing this collection of information. Send comments regarding this burden estimate or any other aspect of this collection of information, including suggestions for reducing this burden to Department of Defense, Washington Headquarters Services, Directorate for Information Operations and Reports (0704-0188), 1215 Jefferson Davis Highway, Suite 1204, Arlington, VA 22202-4302. Respondents should be aware that notwithstanding any other provision of law, no person shall be subject to any penalty for failing to comply with a collection of information if it does not display a currently valid OMB control number. **PLEASE DO NOT RETURN YOUR FORM TO THE ABOVE ADDRESS.**

<b>1. REPORT DATE (DD-MM-YYYY)</b> xx-xx-2002		<b>2. REPORT TYPE</b> Technical		<b>3. DATES COVERED (From - To)</b> 21-12-2001 to 31-12-2004	
<b>4. TITLE AND SUBTITLE</b> System architecture and operational issues of ocean observatories as exemplified by the Martha's Vineyard Coastal Observatory, a cabled platform for long-term studies				<b>5a. CONTRACT NUMBER</b>	
				<b>5b. GRANT NUMBER</b> N00014-01-1-0029	
				<b>5c. PROGRAM ELEMENT NUMBER</b>	
<b>6. AUTHOR(S)</b> McElroy, Marguerite K. Edson, James B. McGillis, Wade R. Austin, Thomas Purcell, Michael J.				<b>5d. PROJECT NUMBER</b>	
				<b>5e. TASK NUMBER</b>	
				<b>5f. WORK UNIT NUMBER</b>	
<b>7. PERFORMING ORGANIZATION NAME(S) AND ADDRESS(ES)</b> Woods Hole Oceanographic Institution Woods Hole, MA 02543				<b>8. PERFORMING ORGANIZATION REPORT NUMBER</b> WHOI Contribution No. 10590	
<b>9. SPONSORING / MONITORING AGENCY NAME(S) AND ADDRESS(ES)</b> Office of Navel Research Environmental Sciences Arlington, VA 22217-5660					
<b>12. DISTRIBUTION / AVAILABILITY STATEMENT</b> A Approved for public release; distribution is unlimited.					
<b>13. SUPPLEMENTARY NOTES</b> In citing this report in a bibliography, the reference given should read: Underwater Intervention 2002 Conference Proceedings, 8 pp., 2002					
<b>14. ABSTRACT</b> During the 20 <sup>th</sup> century the study of the oceans has moved from episodic sampling of organisms and the physical characteristics of the water to an attempt to elucidate the dynamic processes occurring not just within the water column but extending into both the benthic and atmospheric boundary layers. Attempts to extrapolate from these point observations, to understand and model these processes have demonstrated the need for continuous high resolution synoptic sampling from long-term, stable platforms. The Martha's Vineyard Coastal Observatory (MVCO), installed on the exposed south coast of the island of Martha's Vineyard, is one approach to meeting this need. It was designed to provide scientists with an expandable network of stable and varied instrument platforms for the long-term study of dynamic processes occurring in the ocean and at the ocean-atmosphere interface.					
<b>15. SUBJECT TERMS</b> observatory; fiber-optic; network; telemetry; cable; instrumentation					
<b>16. SECURITY CLASSIFICATION OF:</b>			<b>17. LIMITATION OF ABSTRACT</b> Unclassified Unlimited	<b>18. NUMBER OF PAGES</b> 8	<b>19a. NAME OF RESPONSIBLE PERSON</b> Marguerite K. McElroy
<b>a. REPORT</b> UNCLASSIFIED	<b>b. ABSTRACT</b> UNCLASSIFIED	<b>c. THIS PAGE</b> UNCLASSIFIED			<b>19b. TELEPHONE NUMBER (include area code)</b> 508-289-2237

20030618 121

AQM03-08-2075

# System Architecture and Operational Issues of Ocean Observatories as Exemplified by the Martha's Vineyard Coastal Observatory, A Cabled Platform for Long-Term Studies

Marguerite K. McElroy, James B. Edson, Wade R. McGillis, Thomas Austin, Michael J. Purcell  
Woods Hole Oceanographic Institution  
Department of Applied Ocean Physics and Engineering  
Woods Hole, MA 02543  
Email: [mmcelroy@whoi.edu](mailto:mmcelroy@whoi.edu)

## ABSTRACT

During the twentieth century the study of the oceans has moved from episodic sampling of organisms and the physical characteristics of the water to an attempt to elucidate the dynamic processes occurring not just within the water column but extending into both the benthic and atmospheric boundary layers<sup>1</sup>. Attempts to extrapolate from these point observations, to understand and model these processes have demonstrated the need for continuous high resolution synoptic sampling from long-term, stable platforms.

The Martha's Vineyard Coastal Observatory (MVCO), installed on the exposed south coast of the island of Martha's Vineyard, is one approach to meeting this need.<sup>2</sup> It was designed to provide scientists with an expandable network of stable and varied instrument platforms for the long-term study of dynamic processes occurring in the ocean and at the ocean-atmosphere interface. This paper will discuss the MVCO configuration as an exemplar for addressing diverse scientific needs and its role in a potential network of varied observatories. Observatory design needs to address the specific environmental issues at the selected site while providing a simple means of access that will allow the scientists to standardize their installations for mobility amongst these diverse facilities.

## SYSTEM CONSIDERATIONS

### The Site

This locus was selected for its unprotected exposure to the forcing winds along the East coast of the United States. A long, straight south-facing beach provides ideal exposure to the severe coastal storm events that are of interest to many scientists.

Additionally the low glacial outwash plain and barrier beach provide an arena for long-term observations of long-shore currents, shoreline erosion and bedform migration. The long low shoreline was

also conducive to placement of atmospheric sensors that would sample marine air prior to disruption of flow over land<sup>3</sup>.

The site has relatively simple topography, about 5km west of a complex series of shoals and substantially east of significant headlands. Historical data on the shoreline erosion show a loss of almost 3 meters of beach annually. Recent geological surveys included side scan and subbottom sonar surveys as well as grab and core samples. These have helped to establish an initial geological context for future studies of sediment transport and outwash patterns from the adjacent coastal ponds.

**Figure 1:** The site was selected for its exposure to the prevalent winds and conditions which will complement those found at either the LEO-15 or FRF-Duck observatory sites.

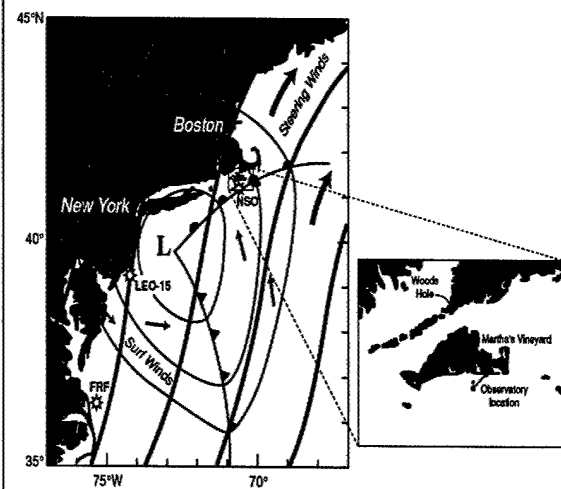

Side scan and sub-bottom sonar mapping and subsequent grab and vibrocore surveys of the area showed correlations between surface sediment grain size and outwash channels and significant bedforms on the sidescan records.

**Figure 2**

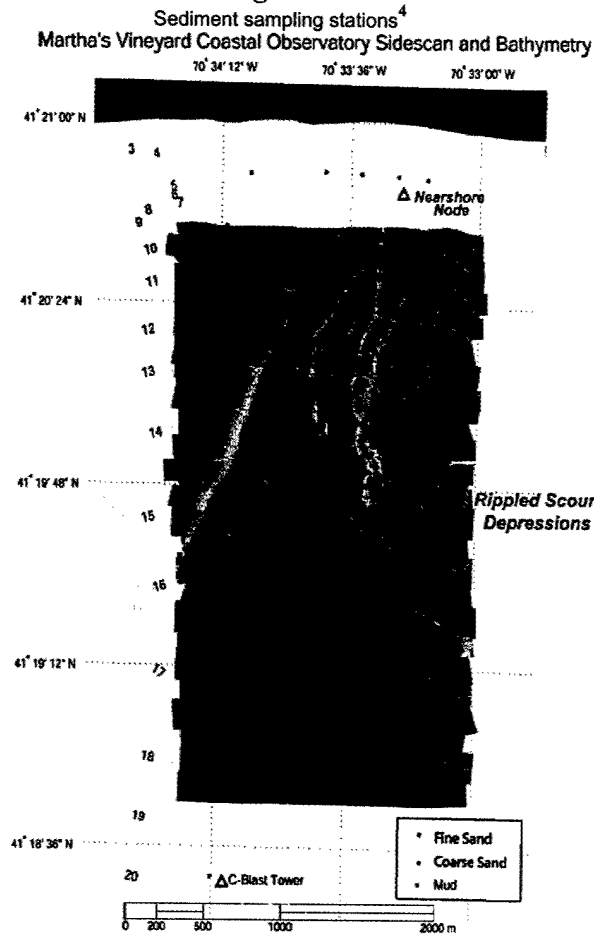

### Observatory Overview

MVCO became operational in the spring of 2001; the current configuration consists of an underwater instrument "node", a land based meteorological sensor mast located near the water's edge, and a shore laboratory with additional meteorological instrumentation. All components are connected by buried fiber-optic cables and are accessible via Woods Hole Oceanographic Institution's (WHOI) network, allowing global access to the observatory via the Internet.

System design and materials were selected for long-term deployment and continuous autonomous operation in severe environmental conditions. The node frame is stainless steel with a high performance epoxy paint and the electronics housing is titanium. A key issue was to provide both sufficient power to facilitate deployment of a varied suite of instrumentation and adequate bandwidth to support

high data rates not possible from battery powered platforms with integral data logging.

System installation considerations focused on selecting methods that would insure minimal impact on the local environment. The system components reside on a rare sandplain grassland at Katama Air Park, span a Herring run, dunes, barrier beach and public waterway. Disturbance of the surface was minimized by the use of directional drilling for the shore approach and offshore cable burial by jetting.<sup>5</sup>

### SYSTEM ARCHITECTURE

#### Power System

The power system, located in a small unmanned shore laboratory on Katama Airpark about 1.5km north of the beach, includes an 8 kVA backup power generator which will automatically sustain operation of the entire system during power outages. Buried electro-optic cables are routed from the shore lab to the sensor mast on the beach and to the seafloor node, providing 4KW power at the offshore node and 2KW at the met mast. Data rates of 1GB are available over 10 single mode fibers and the observatory is linked to WHOI via a commercial T-1 data communications link.

Each guest port contains internal AC/DC converters, which provide the user with isolated 12 Volt and 24 Volt DC power supplies at up to 100 watts each, from the unregulated AC source. These power supply outputs are filtered to minimize common mode and differential noise. They can be used independently, in series or connected by a common ground. Separate ground fault sensing can be provided for each guest port. This power isolation prevents problems from one port propagating to others. Port monitoring and control are provided by Motorola 68HC11 micro-controller. Both the AC input and DC can be cycled, in addition voltage and current status are monitored.

#### Underwater Node

The main underwater node is located on the seabed at 12 meters depth, approximately 1.5 km offshore. Much of the node design has benefited from experience gained at the LEO-15 observatory which was designed and installed by WHOI engineers for the Rutgers University Institute of Marine and Coastal Sciences.<sup>6</sup> The LEO installation has an

**TABLE 1**

Currently deployed instruments at the 12M underwater node located 1.5KM south of Edgartown Great Pond and 8M meteorological mast on South Beach. Sensors whose data will be available on the MVCO web page have been designated by both the principal researcher's name and "Public". Additional sensors at the shore lab include rainfall, solar and infrared radiation.

Port	NODE Instrument	PWR	Baud Protocol	Data	Data Availability
1	Elec. Leak				System
2	xfrmr leak				System
3	Sontek ADP, CT, Pressure	24V	9600 RS-232	Waves, currents, salinity, temp	Richardson, NRL
4	NRL optical sediment	24V	9600 RS-422	Burial depth	Richardson, NRL
6	Gas Tension Device	12V	9600 RS-232	Dissolved gasses	McNeil, URI
7	Mesotec SS Sonar	24V	19200 RS-422	Sand wave migration	Traykovski, WHOI
8	Nortek ADV	12V	19200 RS-422	Currents	Traykovski, WHOI
9	ADCP wave guage	24V	19200 RS-422	Currents, waves	McGillis, WHOI Public
A	Paroscientific	12V	9600 RS-232	Depth, waves	McGillis, WHOI Public
B	YSI, CTD, DO, CO <sub>2</sub>	12V	9600 RS-232	Salinity, temp, depth, CO <sub>2</sub> , O <sub>2</sub>	McGillis, WHOI Public
C	Nortek ADV 2	12V	9600 RS-422	Currents, waves	Traykovski, WHOI
D	Imagenix SS sonar	36V/6V	9600 RS-422	Sand wave migration	Traykovski, WHOI
Port	MAST Instrument	PWR	Baud Protocol	Data	Data Availability
1	Gill 3-D Sonic Anemometer	12V	9600 RS-422	Wind Spd, Dir, Air Temp	Edson, WHOI Public
3	Vaisala PTU	12V, 2 4V	9600 RS-232	Air Press, temp, Rel. Humidity	Edson, WHOI Public
4	Solent 2-D Sonic Anemometer	12V	9600 RS-422	Wind Spd	Edson, WHOI Public
5	Campbell CSAT3	12V	9600 RS-232	Wind Spd, Dir, Air Temp	Edson, WHOI Public
8	Axix 2120 Camera	12V, 2 4V	10T Ethernet	Surf Cam	Edson, WHOI Public
9	Licor 7500	24V	9600 RS-232	CO <sub>2</sub> , water vapor, air temp & pressure	Edson, WHOI Public

**Table 2: Guest port pin configuration<sup>7</sup>**

The pins on both types of connectors are arranged as follows:

Pin 1:	12V + (100 Watts max)
Pin 2:	12V Common (Data Common)
Pin 3:	24V + (100 Watts max)
Pin 4:	24V Common
Pin 5:	Data output (from node): Ethernet Data TX+, RS-232 TX, or RS-422 TX A
Pin 6:	Data output (from node): Ethernet Data TX-, or RS-422 TX B
Pin 7:	Data input (from instrument): Ethernet Data RX+, RS-232 RX, or RS-422 RX A
Pin 8:	Data input (from instrument): Ethernet Data RX-, or RS-422 RX B

**Table 3: Connector specifications<sup>8</sup>**

Each port is assigned an 8-pin connector, the connectors on the seafloor node are easily accessible by the diver and may be mated and unmated underwater.

Location	User Plug Type	Locking Sleeve
Met Mast	Impulse VMK-8-FS	K-FLS-P
Seafloor Node	Impulse IE-8-M	D-LSB-F

integral winch for the operation of a vertical profiler. Since this was not required at MVCO, a substantially smaller node shell (approximately a 4 foot cube) has been used, mounted on a one foot diameter column jetted into the seafloor. This configuration simplifies recovery of the upper instrument frame by a small research vessel for annual maintenance. Lifting the instrument frame off the seafloor is expected to avoid issues with sand intrusion and scouring that have been a problem at LEO-15.

A variety of factors affected the criteria for selection of the suite of core instrumentation for permanent deployment. It was desired to meet the dual purpose of providing scientists with certain fundamental parameters as well as data that was desirable for public outreach in the schools and community. An Acoustic Doppler Current Profiler (RD Instruments Workhorse ADCP Wavegauge), an oceanographic sonde (YSI 6600) which monitors a wide range of water properties, and a Paroscientific pressure sensor provide salinity, temperature, depth, dissolved oxygen and carbon dioxide, current speed and direction, wave height and direction.

Divers can install instrumentation by mounting it in pre-tapped holes on the node frame or nearby and running their cable to the node frame. The divers plug into a connector panel on the node frame rather than directly to the electronics housing. This provides protection to the integrity of the electronics housing by removing the risk of flooding due to a connector damaged during mating. The cables utilize a standard underwater-mateable 8 pin Impulse connector. This implementation strategy is the same as at the LEO-15 observatory and users have been able to bring their instrument directly from a deployment there to an installation at MVCO.

An additional offshore node is planned for the near future to be located approximately 3.5km south west in about 20 meters water depth. This second node will focus on providing a stable platform for studies of air-sea boundary layer dynamics. It will consist of an ASIT (Air Sea Interaction Tower), an oversized version of the basic oceanographic tripod structure with the addition of a meteorological tower extending above the surface. This will allow sampling of an extensive suite of parameters throughout the water column from a few centimeters off the bottom to 10 meters into the atmosphere.

### Meteorological Sensor Mast

An 8M tall meteorological sensor mast is located on the beachfront, in order to accurately measure marine atmospheric variables that have been transported over the water to shore. The met-mast has a core set of sensors that include a 3-axis ultra-sonic anemometer/thermometer (Solent R3) and an infrared hygrometer/CO<sub>2</sub> sensor (LI-COR 7500), as well as mean wind speed, wind direction, relative humidity, temperature, pressure, and CO<sub>2</sub> sensors. A small mast alongside the lab includes additional meteorological sensors that measure solar and infrared radiation, rainfall, temperature, humidity, and wind speed and direction. Instrument cabling is protected by running down inside the hollow monopole and plugs directly into the electronics housing using a standard 8-pin Impulse connector. The cables and terminations at the base of the mast are protected by a locked aluminum cowling that is bolted to the foundation. Instruments can be mounted directly to the mast or along the seven foot long cross arm.

**Figure 3: The Seafloor Node** is constructed on a pedestal, permanently jetted into the seabed, supporting an instrument frame about 1m above the sand. Doors provide easy access for divers to the instrument connector panel connector panel.

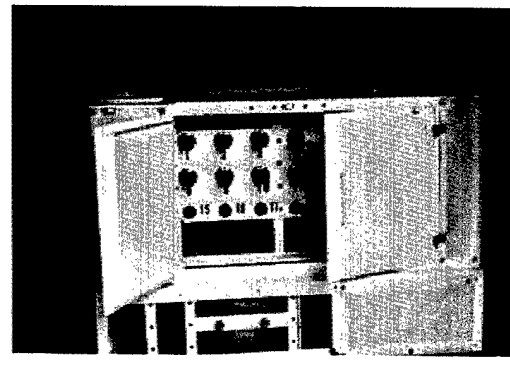

### Networked Data Telemetry

All seafloor node electronics and the met mast data telemetry electronics are essentially identical. The node interface architecture is designed to allow simple integration of any sensor by the implementation of a standard guest port configuration. Each is connected back to the shore laboratory by a 1 Gigabit/sec Ethernet

fiber-optic trunk line, with AC power. A Cisco Systems Ethernet switch provides 24 10/100 BaseT Network connections within the electronics housing at the node and mast<sup>o</sup>. The same Ethernet switch is used at the Shore Laboratory. Each switch contains a single-mode fiber-optic networking module as well as the 24 RJ-45 twisted pair connectors. The buried fiber-optic cables are connected directly to the Cisco Ethernet switch to transmit the networked data at 1 G-bps to and from the shore laboratory. Each guest port provides the user with several power and data communications options.

Each instrument at the node or met mast has an IP address on the node LAN nodes and is linked on the common Ethernet network at the shore laboratory on Martha's Vineyard and then to the WHOI network. In order to provide the highest possible bandwidth to WHOI users, a direct connection to the WHOI campus network was desired. At present a commercial 1.2 Mbps T-1 communication link is being used. Local loggers at the shore lab will save the data for low speed transmission via a dedicated 56K line if the T-1 line goes down. Future expansion to a radio link is being considered to provide greater bandwidth and potentially improve reliability.

Because many scientific instruments utilize asynchronous serial communication interfaces such as RS-232, a method was needed to integrate multiple serial ports into the Ethernet data system. Serial baud rates are supported up to 115 kbps. This function is provided by a Cisco Systems Model 2511 Access Server, which supplies 16 serial ports for distribution among the various user ports. The communications server has an Ethernet interface that connects to one of the network ports on the Ethernet switch. The user can access the instruments using one of the serial interfaces either using a direct IP address, TELNET or commercial com-port redirection software from anywhere on the Internet. Users can also use their own customized access software.

Users can elect to implement or over-ride automatic data fault monitoring. This can detect conditions such as over-current and automatically shut down the instrument without affecting any of the other instrument ports. At present individual sensor ground fault indicators are disabled but this option is expected to be activated after the spring maintenance period.

For the present ground faults are indistinguishable from data fault conditions.

## OPERATIONAL ISSUES

Initially it appeared that the key management issue would be creating a standard, versatile guest port interface that would provide users with several power and data options. This was merely the tip of the iceberg compared to the logistical hurdles of maintenance and user installations.

Due to the cost of ship time, even when using relatively small coastal vessels, and the extreme exposure of the site to seas that will jeopardize the dive operations necessary for instrument deployment, system access for testing must be provided on shore prior to installation at the underwater node. To provide this facility a test box was developed that contains a standard guest port board linked to a Cisco 2511 router. Users connect using the cable and connector that will be used for the deployment. Using the full cable length can be critical to detecting significant voltage drops that will occur if the instrument is to be deployed at a substantial distance from the node.

Protecting the integrity of the underwater assets has proven somewhat challenging. Within the first five months of operation instrument deployments had created a spider web of cables from the node to distances as great as 150 meters. Despite a lighted guard buoy situated about 100 meters South and a posted notice to mariners the instruments are at risk of being hooked by sport fishermen. The public availability of the data, in fact increases the likelihood of the site becoming a popular "artificial reef".

In order to simplify maintenance and installation operations two 900 pound locomor anchors have been installed approximately 45 feet to the northeast and southwest of the node. These have a ground chain to the node and a vertical line to a surface float and are intended to serve as diver down lines. However it is unrealistic to assume that someone won't attempt to use them as an anchor and lacking scope the vessel buoyancy will cause these to drag. It became clear that permanent moorings needed to be

**Figure 4: MVCO DATA NETWORK** <sup>9</sup>

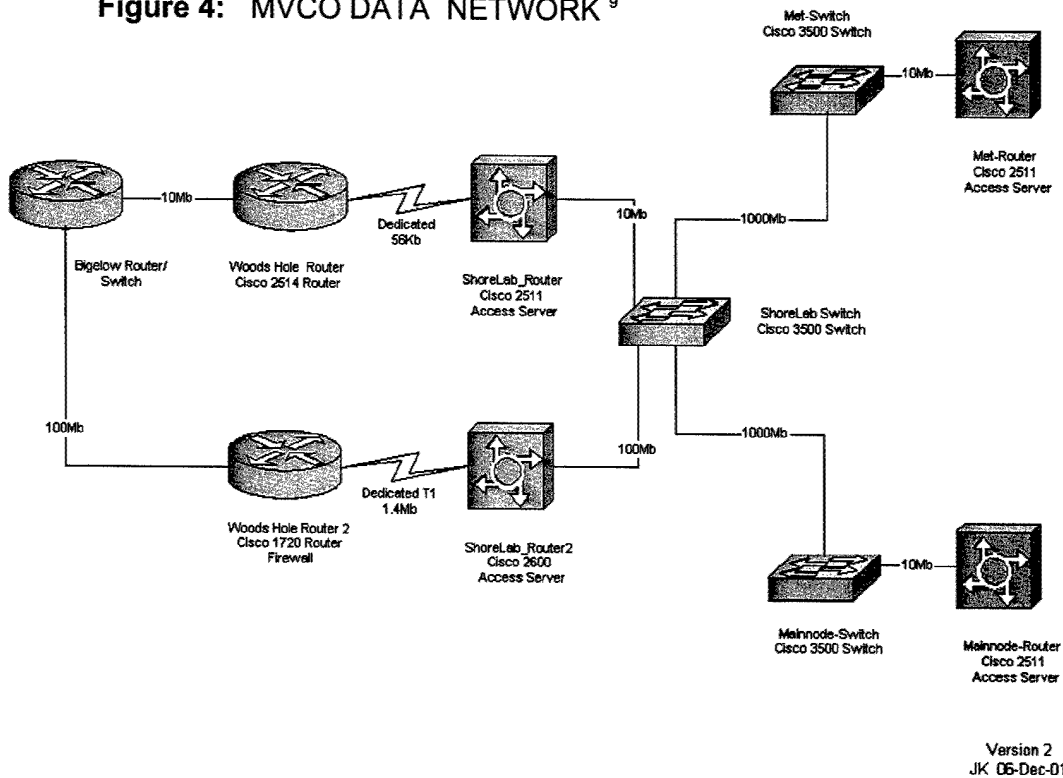

**Figure 5: MVCO Seafloor Node Power/Data Block Diagram.**  
(Met-Mast Node is identical except there is no step-down transformer.)

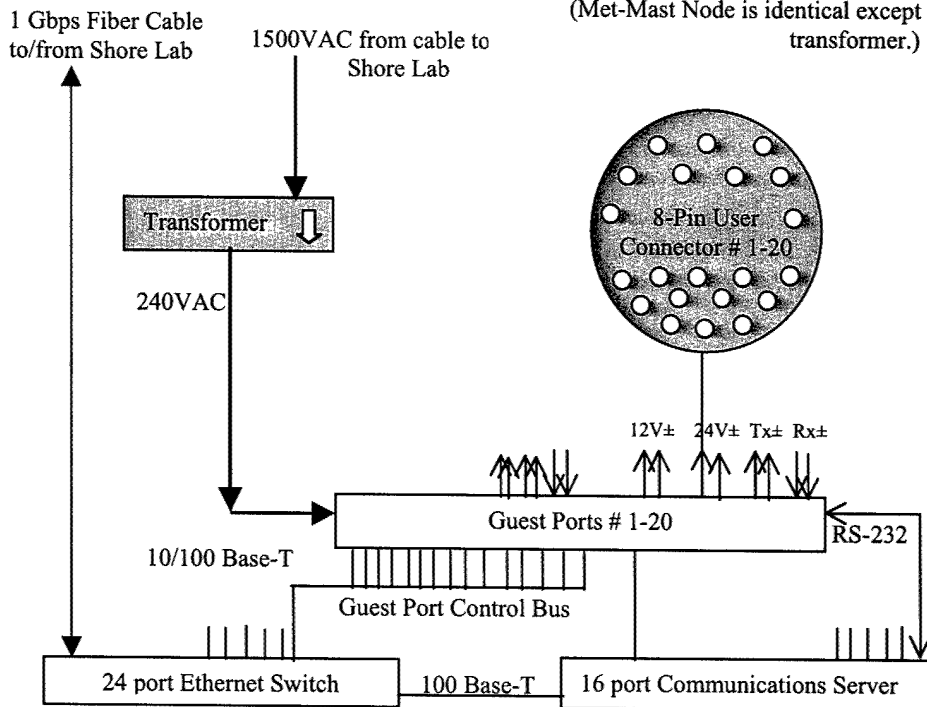

be installed capable of handling a 25-50 foot vessel. These will need to be at sufficient distance for adequate scope for the 12 meter depth as well as to keep the buoy watch circle clear of both the moored instruments, their cables and the flow field of the current meters as well as the beam pattern of the up-looking acoustic devices. Establishing both moorings and diver access markers have the potential for creating an obstacle course for any vessel attempting to work in the vicinity.

Instruments that are mounted at a distance from the node are required to have a yale grip installed between the connector panel and the instrument to prevent excessive tugging on the node if the instrument should become fouled by a surface vessel. Several of these installations are mounted on monopods that support the instrument a meter or more above the seafloor. Some cables have been jetted in and others have been weighted with the expectation of self-burial. Until this occurs the cables are vulnerable to damage from the down-line anchors, if they are dragged up by a surface vessel.

The sides of the node are equipped with plastic panels to help minimize the intrusion of lines, hooks or anchors. Some of these panels have already been removed to facilitate diver access for maintenance but most will remain in place to protect the instrument cables to the electronics housing and the fiber connections from it to the oil-filled termination box. Some additional modifications will need to be made to facilitate efficient diver access without exposing the less robust elements of the structure.

WHOI has historically had minimal need for surface supply dive operations but these dive operations are going to become an important capability to develop in order to support this facility. Although commercial divers will still need to be hired for the heavier operations, science divers are being trained to use surface supply and perform some jetting operations. The Institution is in the early stages of upgrading its fleet of small coastal vessels, currently designing a replacement for the 45 foot R/V Asterias. The new vessel will need to be equipped to support this wider variety of dive operations.

Although the node frame is grounded and should pose no electrical threat to divers, the policy is to shut down the power before divers contact the frame. When the power is on, a bright blue diver

warning LED is visible through a port beneath the doors to the connector panel. This light has proven visible even with extensive bio-fouling on the port.

During the summer season the instruments have very rapidly become overcome with bio-fouling. Extensive diver effort must be expended to scrape the node and instruments and swap out instruments for cleaning and recalibration.

The observatory was initially conceived with two nodes, the existing one at 12 meter depth, and an additional one at 6 meter depth. Due to budget constraints the shallow node was not built. This leaves the existing node with only twenty guest ports which are rapidly filling up. The Met mast has only four remaining of its ten guest boards. The planned expansion of the observatory to include a 20 meter installation should alleviate this potential crowding but it is probable the science policy committee will be faced with making some tough priority decisions in the future.

Communication with the geographically remote user community can be facilitated by use of the internet but will require some effort to establish the necessary support levels. The level of field experience and technological knowledge of instrumentation of the user community is wide ranging and it is clear that some users are going to need substantially more support for their installations if they are going to have a successful experience at MVCO.

## CONCLUSION

MVCO is a significant step in moving forward the technology for long-term studies of dynamic processes in the ocean and at its interface. It is now clear that the design concepts are sound, especially as regards the flexibility of the guest port interface. The management strategy is moving towards a user-responsive system and will need consistent support to continue to develop the necessary tools for efficient field operations.

As a network of diverse observatories along the East Coast gradually becomes a reality the enormous task of integrating the data from the buoy systems of GOMOOS and NDBC, cabled observatories such as LEO-15 in New Jersey and MVCO, and the FRF installation at Duck, North Carolina will have to be faced. Will the potential

be realized or will the various data sets languish independently? Will the leadership develop to leverage the necessary funds to integrate and utilize these tools effectively? As the network expands will the limited resources be able to support multiple facilities? The scientific community will need to be as creative with its management strategies as it is with its science initiatives if it is to meet these challenges.

### ACKNOWLEDGEMENT

This work was done under ONR contract N00014-01-1-0029. We would also like to thank Peter Traykovski and John Krauspe for use of unpublished data as well as Tom O'Brien and the mapping team of the US Geological Survey, Woods Hole.

WHOI Contribution # 10590

---

Coastal Observatory, *Journal of Ocean Engineering*, submitted.

<sup>8</sup> Austin, T. A., Draft: MVCO Guest Board Interface Document.

<sup>9</sup> Krauspe, J. personal communication.

---

<sup>1</sup> Lentz, S.J., and J.H. Trowbridge, "The bottom boundary layer over the northern California shelf," *J. Phys. Oceanog.*, vol. 21, pp. 1186-1201, 1991.

<sup>2</sup> Edson, J.B., W. R. McGillis, and T. C. Austin, "A new coastal observatory is born," *Oceanus*, vol. 42, pp. 31-33, 2000.

<sup>3</sup> Austin, Edson, McGillis, Purcell, Petitt, McElroy, Grant, "A Network-Based Telemetry Architecture Developed for the Martha's Vineyard Coastal Observatory", *Journal of Ocean Engineering*, submitted.

<sup>4</sup> Traykovski, P., personal communication.

<sup>5</sup> McElroy, M.K., J. B. Edson, T. C. Austin, W. R. McGillis, M. J. Purcell, "Underwater Observatories: The Challenges and Promise of Applying Off-Shore Cable Technology to Long-Term Environmental Studies", *Proceedings Underwater Intervention-2001*, MTS/ADC, Doyle Publishing, Houston TX, Jan. 21-27, 2001.

<sup>6</sup> Forrester, N.C., R. P. Stokey, C. J. von Alt, B. G. Allen, R. G. Goldsborough, M. J. Purcell, and T. C. Austin, "The LEO-15 long term ecosystem observatory: Design and installation," *Proceedings Oceans '97*, Vol. 2, pp. 1082-1088, Halifax, Canada.

<sup>7</sup> T. Austin, J. Edson, W. McGillis, et al, A Network-Based Telemetry Architecture Developed for the Martha's Vineyard