

AD

MEMORANDUM REPORT ARCCB-MR-03001

BAUSCHINGER TEST FIXTURE

**C. MOSSEY
E. TROIANO
F. PFINDEL**

FEBRUARY 2003



**US ARMY ARMAMENT RESEARCH,
DEVELOPMENT AND ENGINEERING CENTER**
Close Combat Armaments Center
Benét Laboratories
Watervliet, NY 12189-4000



APPROVED FOR PUBLIC RELEASE; DISTRIBUTION UNLIMITED

20030613 126

DISCLAIMER

The findings in this report are not to be construed as an official Department of the Army position unless so designated by other authorized documents.

The use of trade name(s) and/or manufacturer(s) does not constitute an official endorsement or approval.

DESTRUCTION NOTICE

For classified documents, follow the procedures in DoD 5200.22-M, Industrial Security Manual, Section II-19, or DoD 5200.1-R, Information Security Program Regulation, Chapter IX.

For unclassified, limited documents, destroy by any method that will prevent disclosure of contents or reconstruction of the document.

For unclassified, unlimited documents, destroy when the report is no longer needed. Do not return it to the originator.

REPORT DOCUMENTATION PAGEForm Approved
OMB No. 0704-0188

Public reporting burden for this collection of information is estimated to average 1 hour per response, including the time for reviewing instructions, searching existing data sources, gathering and maintaining the data needed, and completing and reviewing the collection of information. Send comments regarding this burden estimate or any other aspect of this collection of information, including suggestions for reducing this burden, to Washington Headquarters Services, Directorate for Information Operations and Reports, 1215 Jefferson Davis Highway, Suite 1204, Arlington, VA 22202-4302, and to the Office of Management and Budget, Paperwork Reduction Project (0704-0188), Washington, DC 20503.

1. AGENCY USE ONLY (Leave Blank)		2. REPORT DATE February 2003	3. REPORT TYPE AND DATES COVERED Final	
4. TITLE AND SUBTITLE BAUSCHINGER TEST FIXTURE			5. FUNDING NUMBERS AMCMS No. 6226.24.H180.0 PRON No. TU1G1F261ABJ	
6. AUTHORS C. Mossey, E. Troiano, and F. Pfindel				
7. PERFORMING ORGANIZATION NAME(S) AND ADDRESS(ES) U.S. Army ARDEC Benet Laboratories, AMSTA-AR-CCB-O Watervliet, NY 12189-4000			8. PERFORMING ORGANIZATION REPORT NUMBER ARCCB-MR-03001	
9. SPONSORING / MONITORING AGENCY NAME(S) AND ADDRESS(ES) U.S. Army ARDEC Close Combat Armaments Center Picatinny Arsenal, NJ 07806-5000			10. SPONSORING / MONITORING AGENCY REPORT NUMBER	
11. SUPPLEMENTARY NOTES				
12a. DISTRIBUTION / AVAILABILITY STATEMENT Approved for public release; distribution unlimited.			12b. DISTRIBUTION CODE	
13. ABSTRACT (Maximum 200 words) Evaluating the Bauschinger effect on ASTM A723 gun steel necessitated the design and fabrication of a specialized fixture that remained rigid and properly aligned during testing. The configuration of the fixture can be easily modified to accommodate various specimen geometries and monitoring devices. This fixture did not allow specimen bending or buckling and was successful in obtaining accurate Bauschinger data.				
14. SUBJECT TERMS Bauschinger Effect, Bauschinger Testing, Cyclic Testing, ASTM A723, Mechanical Testing, Test Fixture			15. NUMBER OF PAGES 3	
			16. PRICE CODE	
17. SECURITY CLASSIFICATION OF REPORT UNCLASSIFIED	18. SECURITY CLASSIFICATION OF THIS PAGE UNCLASSIFIED	19. SECURITY CLASSIFICATION OF ABSTRACT UNCLASSIFIED	20. LIMITATION OF ABSTRACT UL	

TABLE OF CONTENTS

	<u>Page</u>
INTRODUCTION.....	1
ASSEMBLY OF FIXTURE	2
TEST PROCEDURE.....	2
SUMMARY	2

LIST OF ILLUSTRATIONS

1. Bauschinger test fixture configuration	1
2. Test specimen configuration	1

INTRODUCTION

The testing of ASTM A723 gun steel for Bauschinger effect made it necessary to design a unique fixturing device. The nature of the testing required that the specimen go through continuous tensile and compression loading cycles. Since the specimen experiences a complete reversal in the direction of the loading, it must be firmly supported and secured. This fixture (Figure 1) allowed the specimen to be precisely assembled in the device, remain in line with the loading axis of the test machine, and maintain a near zero bending load on the specimen. The configuration of the test fixture can easily be modified to accommodate specimens with configurations other than that shown in Figure 2.

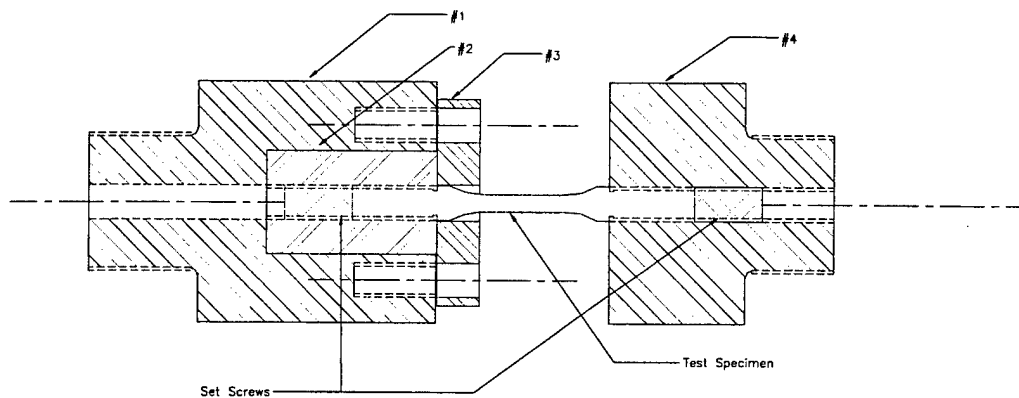

Figure 1. Bauschinger test fixture configuration.

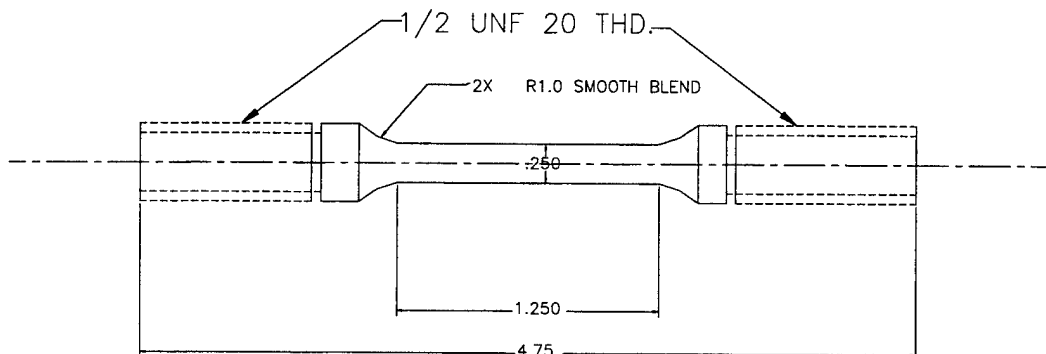

Figure 2. Test specimen configuration.

ASSEMBLY OF FIXTURE

The fixture base (part #1) is threaded into the actuator of the test machine. The specimen (Figure 2) is threaded into part #2 of the fixture to the desired depth. A setscrew is then threaded into part #2 from the opposite end and tightened against the specimen. Part #3 is slid over the specimen and the remaining end of the specimen is threaded in part #4. A setscrew is then threaded into the opposite end of part #4 and tightened against the specimen. Part #4 is threaded into the load cell of the testing machine. The actuator is raised until part #2 is bottomed out in part #1 (part #2 stands proud of #1). Finally, cap screws are used to secure the retainer plate (#3) to the fixture base (#1).

TEST PROCEDURE

With the test fixture and specimen in place a one-inch extensometer is secured to the specimen. Next the testing machine is run in a cyclic mode to the predetermined strain and number of cycles desired. The data are read into an Excel file, then plotted and analyzed.

SUMMARY

The fixture firmly held and aligned the specimen and did not allow it to bend or buckle as it went through continuous tensile and compressive loading cycles. The fixture made it possible to obtain accurate Bauschinger data.

TECHNICAL REPORT INTERNAL DISTRIBUTION LIST

	<u>NO. OF COPIES</u>
TECHNICAL LIBRARY ATTN: AMSTA-AR-CCB-O	1
TECHNICAL PUBLICATIONS & EDITING SECTION ATTN: AMSTA-AR-CCB-O	3
PRODUCTION PLANNING & CONTROL DIVISION ATTN: AMSTA-WV-ODP-Q, BLDG. 35	1

NOTE: PLEASE NOTIFY DIRECTOR, BENÉT LABORATORIES, ATTN: AMSTA-AR-CCB-O OF ADDRESS CHANGES.

TECHNICAL REPORT EXTERNAL DISTRIBUTION LIST

	<u>NO. OF COPIES</u>		<u>NO. OF COPIES</u>
DEFENSE TECHNICAL INFO CENTER ATTN: DTIC-OCA (ACQUISITIONS) 8725 JOHN J. KINGMAN ROAD STE 0944 FT. BELVOIR, VA 22060-6218	2	COMMANDER U.S. ARMY RESEARCH OFFICE ATTN: TECHNICAL LIBRARIAN P.O. BOX 12211 4300 S. MIAMI BOULEVARD RESEARCH TRIANGLE PARK, NC 27709-2211	1
COMMANDER U.S. ARMY ARDEC ATTN: AMSTA-AR-WEE, BLDG. 3022	1	COMMANDER ROCK ISLAND ARSENAL	
AMSTA-AR-AET-O, BLDG. 183	1	ATTN: SIORI-SEM-L	1
AMSTA-AR-FSA, BLDG. 61	1	ROCK ISLAND, IL 61299-5001	
AMSTA-AR-FSX	1		
AMSTA-AR-FSA-M, BLDG. 61 SO	1	COMMANDER	
AMSTA-AR-WEL-TL, BLDG. 59	2	U.S. ARMY TANK-AUTMV R&D COMMAND	
PICATINNY ARSENAL, NJ 07806-5000		ATTN: AMSTA-DDL (TECH LIBRARY)	1
		WARREN, MI 48397-5000	
DIRECTOR U.S. ARMY RESEARCH LABORATORY ATTN: AMSRL-DD-T, BLDG. 305 ABERDEEN PROVING GROUND, MD 21005-5066	1	COMMANDER U.S. MILITARY ACADEMY ATTN: DEPT OF CIVIL & MECH ENGR WEST POINT, NY 10966-1792	1
DIRECTOR U.S. ARMY RESEARCH LABORATORY ATTN: AMSRL-WM-MB (DR. B. BURNS) ABERDEEN PROVING GROUND, MD 21005-5066	1	U.S. ARMY AVIATION AND MISSILE COM REDSTONE SCIENTIFIC INFO CENTER ATTN: AMSAM-RD-OB-R (DOCUMENTS) REDSTONE ARSENAL, AL 35898-5000	2
CHIEF COMPOSITES & LIGHTWEIGHT STRUCTURES WEAPONS & MATLS RESEARCH DIRECT	1	NATIONAL GROUND INTELLIGENCE CTR ATTN: DRXST-SD 2055 BOULDERS ROAD CHARLOTTESVILLE, VA 22911-8318	1
U.S. ARMY RESEARCH LABORATORY ATTN: AMSRL-WM-MB (DR. BRUCE FINK) ABERDEEN PROVING GROUND, MD 21005-5066			

NOTE: PLEASE NOTIFY COMMANDER, ARMAMENT RESEARCH, DEVELOPMENT, AND ENGINEERING CENTER,
BENÉT LABORATORIES, CCAC, U.S. ARMY TANK-AUTOMOTIVE AND ARMAMENTS COMMAND,
AMSTA-AR-CCB-O, WATERVLIET, NY 12189-4050 OF ADDRESS CHANGES.
