

AD

Award Number: DAMD17-99-1-9546

TITLE: Kainate Receptors in the Striatum: Implications for  
Excitotoxicity in Huntington's Disease

PRINCIPAL INVESTIGATOR: Yoland Smith, Ph.D.

CONTRACTING ORGANIZATION: Emory University  
Atlanta, Georgia 30322

REPORT DATE: August 2002

TYPE OF REPORT: Annual

PREPARED FOR: U.S. Army Medical Research and Materiel Command  
Fort Detrick, Maryland 21702-5012

DISTRIBUTION STATEMENT: Approved for public release;  
Distribution unlimited

The views, opinions and/or findings contained in this report are those of the author(s) and should not be construed as an official Department of the Army position, policy or decision unless so designated by other documentation.

BEST AVAILABLE COPY

20030731 150

BEST AVAILABLE COPY

**REPORT DOCUMENTATION PAGE**Form Approved  
OMB No. 074-0188

Public reporting burden for this collection of information is estimated to average 1 hour per response, including the time for reviewing instructions, searching existing data sources, gathering and maintaining the data needed, and completing and reviewing this collection of information. Send comments regarding this burden estimate or any other aspect of this collection of information, including suggestions for reducing this burden to Washington Headquarters Services, Directorate for Information Operations and Reports, 1215 Jefferson Davis Highway, Suite 1204, Arlington, VA 22202-4302, and to the Office of Management and Budget, Paperwork Reduction Project (0704-0188), Washington, DC 20503

1. AGENCY USE ONLY (Leave blank)		2. REPORT DATE August 2002	3. REPORT TYPE AND DATES COVERED Annual (15 Jul 01 - 14 Jul 02)	
4. TITLE AND SUBTITLE Kainate Receptors in the Striatum: Implications for Excitotoxicity in Huntington's Disease			5. FUNDING NUMBERS DAMD17-99-1-9546	
6. AUTHOR(S) Yoland Smith, Ph.D.				
7. PERFORMING ORGANIZATION NAME(S) AND ADDRESS(ES) Emory University Atlanta, Georgia 30322  E-MAIL: yolands@rmy.emory.edu			8. PERFORMING ORGANIZATION REPORT NUMBER	
9. SPONSORING / MONITORING AGENCY NAME(S) AND ADDRESS(ES) U.S. Army Medical Research and Materiel Command Fort Detrick, Maryland 21702-5012			10. SPONSORING / MONITORING AGENCY REPORT NUMBER	
11. SUPPLEMENTARY NOTES report contains color				
12a. DISTRIBUTION / AVAILABILITY STATEMENT Approved for Public Release; Distribution Unlimited			12b. DISTRIBUTION CODE	
13. ABSTRACT (Maximum 200 Words)  Huntington's disease (HD) is a neurodegenerative condition characterized by a loss of projection neurons in the striatum. Although various hypotheses have been proposed to explain the mechanisms that underlie the striatal neuronal death, excitotoxicity still deserves major interest. Recent findings indicate that changes in the genotype of the kainate receptor subunit, GluR6, are associated with variation in the age of onset of HD, which implicates the kainate receptors in the pathogenesis of HD. The rationale of this project is that pre-synaptic kainate receptors control the release of glutamate from cortical or thalamic terminals, and that an abnormal regulation of these receptors is involved in the death of striatal neurons in HD. We, therefore, propose to use state-of-the-art electron microscope techniques to test a series of hypotheses that will help to elucidate the localization and understand better the role of kainate receptors in the primate striatum. The results of these studies will provide a strong basis for studying the potential mechanisms by which these receptors participate in the death of striatofugal neurons in HD. Moreover, they will help the development of novel therapeutic strategies aimed at targeting pre-synaptic kainate receptors in HD and other basal ganglia disorders.				
14. SUBJECT TERMS neurotoxin			15. NUMBER OF PAGES 122	
			16. PRICE CODE	
17. SECURITY CLASSIFICATION OF REPORT Unclassified	18. SECURITY CLASSIFICATION OF THIS PAGE Unclassified	19. SECURITY CLASSIFICATION OF ABSTRACT Unclassified	20. LIMITATION OF ABSTRACT Unlimited	

NSN 7540-01-280-5500

Standard Form 298 (Rev. 2-89)  
Prescribed by ANSI Std. Z39-18  
298-102

BEST AVAILABLE COPY

## Table of Contents

Cover.....	1
SF 298.....	2
Table of Contents.....	3
Introduction.....	4
Body.....	4
Key Research Accomplishments.....	11
Reportable Outcomes.....	12
Conclusions.....	13
References.....	14
Appendices.....	16

BEST AVAILABLE COPY

## INTRODUCTION

Huntington's disease (HD) is an autosomal dominant neurodegenerative disorder characterized by the death of striatal neurons. Chorea is the most common involuntary movement in patients who suffer of HD. This could be combined with cognitive and memory deficits at a later stage of the disease. The HD mutation was identified in 1993 as an unstable expansion of CAG (trinucleotide) repeats on the gene which encodes the protein "Huntingtin" on chromosome 4. In more than 60% of HD patients, there is a high degree of inverse correlation between the number of CAG repeats and the age of onset of the disease or degree of striatal degeneration (Vonsattel and DiFiglia, 1998). However, about 15% of the HD cases of which the age of onset cannot be explained by the CAG repeats, were found to have mutations in the gene encoding for the GluR6 subunit of the glutamatergic kainate receptor (Rubinztstein et al., 1997; MacDonald et al., 1999); which highlight the importance of those receptors in the pathogenesis of the striatum in HD. Although the existence of kainate receptors has long been established, little is known about their functions and distribution in the central nervous system. Previous data obtained in our laboratory showed that the kainate receptor subunits GluR6/7 are strikingly enriched in the monkey striatum but, in contrast to other ionotropic glutamate receptors which are found almost exclusively at postsynaptic sites, the GluR6/7 kainate receptor subunits are strongly expressed pre-synaptically in glutamatergic terminals (Charara et al., 1999).

Based on these data, the rationale of experiments proposed in this application was that altered functions of pre-synaptic kainate receptors, due to mutations of the GluR6 subunit gene, may induce excessive glutamate release in the striatum, thereby, excitotoxic cell death of striatal projection neurons in Huntington's disease. Before addressing such an issue, a prerequisite is to characterize in detail the synaptic localization of kainate receptors in the striatum. We, therefore, proposed to use a combination of various anatomical and immunocytochemical approaches at the electron microscopic level to elucidate the pattern of subcellular and subsynaptic localization of GluR6 and KA2 subunits of the kainate receptors in the monkey striatum.

## BODY

- **SPECIFIC AIMS**

The original proposal comprised the following specific aims:

**Hypothesis I: The GluR6/7 kainate receptor subunits are strongly expressed by cortical glutamatergic terminals in the monkey striatum.**

*Specific Aim #1:* To elucidate the subsynaptic localization of GluR6/7 immunoreactivity in the striatum using immunoperoxidase and immunogold techniques at the electron microscope level.

*Specific Aim #2:* To demonstrate that GluR6/7-immunoreactive terminals arise from the cerebral cortex using a combination of tract-tracing techniques and pre-embedding immunogold methods.

**Hypothesis II: The pre-synaptic kainate receptors are more frequently encountered in those regions of the striatum that are more sensitive to degeneration in HD.**

*Specific Aim #3:* To compare the relative frequency of GluR6/7-immunoreactive terminals between the rostral and caudal portions of the putamen and between the tail, body and head of the caudate nucleus.

**Hypothesis III: The terminals that express kainate receptor subunits form synaptic contacts preferentially with the "indirect D2-containing" striatofugal neurons which degenerate first in HD.**

*Specific Aim #4:* To compare the relative frequency of synaptic contacts established by GluR6/7-immunoreactive terminals with "direct D1-containing" and "indirect D2-containing" striatofugal neurons.

**Hypothesis IV: The GluR6/7 and KA2 kainate receptor subunits are expressed at pre-and post-synaptic sites in the striatum.**

*Specific Aim #5:* To compare the subsynaptic localization of KA2 and GluR6/7 immunoreactivity in different regions of the striatum.

**Hypothesis V: The diffusion of glutamate from the synaptic cleft to pre-synaptic kainate receptors is controlled by glutamate transporters.**

*Specific Aim #6:* To study the relationships between the glutamate transporters and the GluR6/7-immunoreactive terminals.

• **SUMMARY-LAST YEAR PROGRESS REPORT**

In our last year progress report we presented the data obtained for specific aims #1,2,3 and 5 that have now been completed and published in the *The Journal of Neuroscience* (Appendix 1) and a review in *The Journal of Chemical Neuroanatomy* (Appendix 2). Some of this information was also part of two book chapters (Appendices 3-4) and various abstracts presented at International meetings (Appendices 5-6)

Although data presented in these papers have already been discussed in our last year progress report, I feel appropriate to summarize the main findings of this study to set up the stage for the present report. I will also briefly comment on the implication of these data to understand the potential role of kainate receptors in Huntington's disease pathophysiology.

- (1) The relative abundance of glutamatergic terminals immunoreactive for kainate receptor subunits does not vary throughout the striatum despite the fact that some striatal regions are more sensitive than others to degeneration in Huntington's disease.
  - ❖ *A differential degree of striatal neurodegeneration has been shown in Huntington's disease (Vonsattel and DiFiglia, 1998). For instance, the nucleus accumbens is the least sensitive striatal region whereas the tail of the caudate nucleus is the most affected part of the striatum in the brains of Huntington patients. Assuming that pre-synaptic kainate receptors might be involved in striatal neurodegeneration (see introduction), we hypothesized that this cell death variability might be due to a differential expression of pre-synaptic kainate receptors among striatal territories. However, our data show that such is not the case (Appendix 1), which suggests that the degree of striatal cell death observed in Huntington's disease is not merely the result of a larger number of glutamatergic terminals that express kainate receptors, but likely involves more complex changes in the functional and pharmacological properties of these receptors.*
- (2) Pre- and postsynaptic GluR6/7 and KA2 immunoreactivity is largely expressed intracellularly under basal conditions (Appendix 1).
- (3) Most of the membrane-bound labelling for GLUR6/7 and KA2 is expressed extrasynaptically though synaptic and perisynaptic labelling of glutamatergic synapses is also seen (Appendix 1).

- (4) In immunoreactive terminals, GluR6/7 and KA2 labelling is associated with the membrane of vesicular structures which are randomly distributed relative to the pre-synaptic grid of asymmetric synapses (Appendix 1).
- ❖ *The latter three sets of data are interesting and are consistent with the known physiology of kainate receptors observed in other brain regions. In brief, kainate responses are usually slow and necessitate tetanic stimulation of pre-synaptic afferents to be induced (Lerma et al., 1997; Kamiya, 2002). These functional effects resemble much more responses generated by metabotropic glutamate receptors than other ionotropic receptors such as NMDA and AMPA (Anwyl, 1999; Lerma et al., 1997). The fact that these receptors are either intracellular or largely extrasynaptic, a pattern reminiscent of group I mGluRs in the monkey striatum, raises interesting questions regarding their trafficking, synaptic targeting and mechanisms of activation. Regarding Huntington's disease, an interesting possibility could be that the mutation of the GluR6 gene in HD patients alters the trafficking of this subunit, thereby affects the subsynaptic localization of kainate receptors, which eventually leads to an excessive activation of presynaptic receptors and overflow of extracellular glutamate.*
- (5) More than half of cortical and thalamic inputs from the primary motor cortex and the centromedian nucleus, respectively, express GluR6/7 and KA2 immunoreactivity in the postcommissural putamen (Appendix 1).
- ❖ *Although the cerebral cortex provides the most massive glutamatergic input to the striatum, we and others have shown that the intralaminar thalamic nuclei also contribute substantially to this innervation (Sadikot et al., 1992; Sidibe and Smith, 1996). Here, we demonstrate that both cortical and thalamic afferents express pre-synaptic kainate receptors, which means that an altered regulation of these receptors in HD, due to the mutation of the GluR6 subunit gene, may affect not only the glutamatergic transmission at corticostriatal synapses but also the thalamic influences upon striatal neurons.*

- **PROGRESS REPORT 2001-2002**

- I. **Hypothesis III- Specific Aim #4-Progress**

Over the past year, we have pursued and completed experiments to address Hypothesis III, ie testing whether kainate-containing glutamatergic terminals form synapses more frequently with striato-GPe (so-called "indirect striatofugal neurons") than striato-GPi (so-called "direct striatofugal neurons"). The rationale of this series of studies is that "indirect" striatofugal neurons are more sensitive to neurodegeneration than "direct" striatofugal neurons in Huntington's disease (Vonsattel and DiFiglia, 1998). Our hypothesis was that this differential degree of neurodegeneration might be due to the fact that indirect striatofugal neurons are contacted more frequently by kainate receptor-containing terminals than direct striatofugal neurons. Assuming that presynaptic kainate receptors are malfunctioning in HD, this may lead to an overflow of glutamate at excitatory synapses established more frequently on striatofugal neurons projecting to GPe than striatal neurons projecting to GPi.

To test this hypothesis, we used two different and complementary approaches. The first approach combined the use of D1 and D2 dopamine receptors as markers of the two populations of striatofugal neurons (Gerfen et al., 1990) with GluR6/7 immunoreactivity. In the second

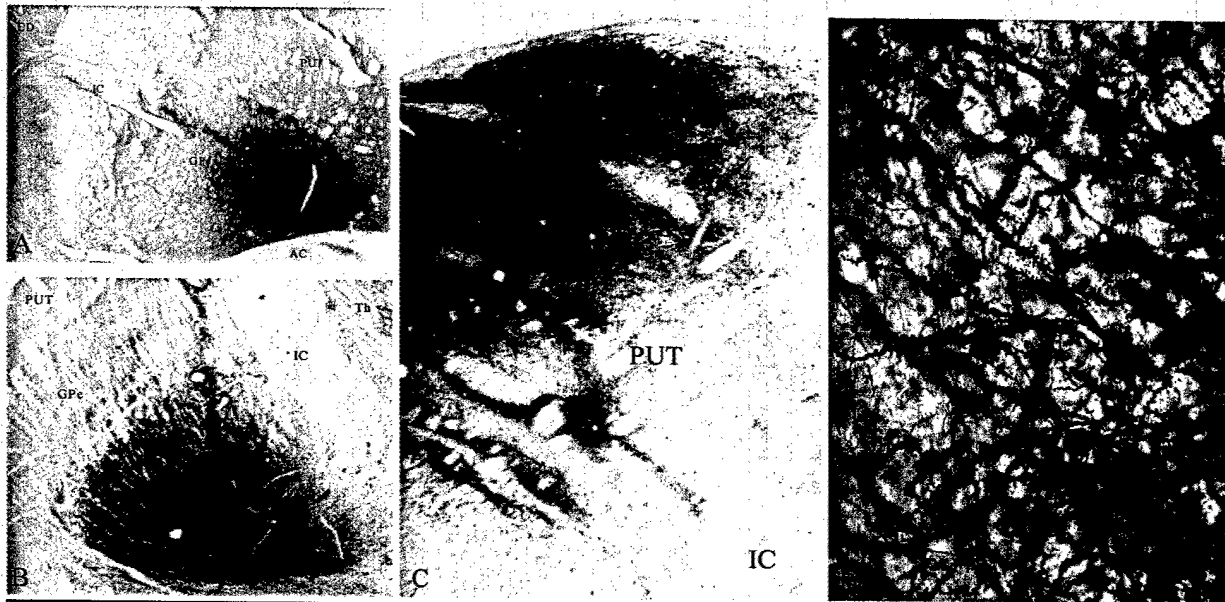

**Figure 1: BDA injection sites in GPe (A) and GPi (B). (C,D) Resulting retrograde labeling in the putamen after GPi injection. Note the extent of dendritic and spine labeling in D.**

approach, we labeled striatofugal neurons retrogradely using biotin dextran amine (BDA) and used GluR6/7 antibodies to label pre-synaptic kainate receptors. A critical factor of this series of experiments was to have markers that label distal dendrites and spines of striatofugal neurons since these are the main targets of kainate receptor-containing boutons. As shown in Figure 1, BDA labeled extensively the whole dendritic tree and spines of striatal projection neurons (Fig. 1C,D). Using pre-embedding immunogold to label GluR6/7 and diaminobenzidine (DAB) as marker of either dopamine receptors or BDA allow to easily differentiate the two sets of labeled elements at the electron microscopic level (Fig. 2). Our approach to analyse this material was as follows: Sections of striatum were scanned for the presence of GluR6/7-containing terminals in the close vicinity of DAB-containing striatal elements. Once such a terminal was found, we determined if it formed a synaptic contact with a labeled or unlabelled postsynaptic profile. If our hypothesis is correct, we should find kainate receptor-containing terminals forming synapses more frequently with indirect (D2-containing; striato-GPe) than direct (D1-containing; striato-GPi) striatofugal neurons. A series of control experiments that have been described in details in the original application have been performed to ascertain the validity of this series of studies.

A total of five monkeys have been used in these experiments. Three animals received injections of BDA in GPe or GPi and two were used for D1 and D2 dopamine receptor labeling. The main findings of this study are shown in table 1 and Figure 2. In brief, our data demonstrate that more than 75% of the spines that were post-synaptic to kainate-containing terminals displayed D2 immunoreactivity or were retrogradely labeled from the GPe (Table 1; Fig. 2A,B). In contrast, less than 10% of spines contacted by kainate-immunoreactive terminals expressed D1

immunoreactivity or were retrogradely labeled from GPi (Fig. 2C,D). Preliminary results of this study have been presented in abstract form at the 2001 Society for Neuroscience meeting in San Diego (Appendix 5). A peer-reviewed paper is currently in preparation and should be submitted before the end of the year.

**Table 1:** *Proportion of Kainate-containing terminals in contact with spines of direct and indirect striatofugal neurons in monkey.*

Animal Number	Processing	%KA Terminals in contact with labeled spines (Number of kainate-positive terminals examined)
1	BDA GPi/GluR6	8 (n=37)
2	BDA GPi/GluR6	10 (n=25)
3	BDA GPe/GluR6	77 (n=43)
4	D1/GluR6	6 (n=32)
5	D2/GluR6	79 (n=11)

The functional implication of these findings are twofolds: (1) They clearly demonstrate that the chemical phenotype of glutamatergic terminals that impinge upon the two main populations of striatofugal projection neurons is different. Until recently, the pattern of excitatory synaptic inputs from the cortex and thalamus to direct and indirect striatofugal neurons was thought to be the same. However, recent findings from our laboratory demonstrated that thalamic inputs from CM target preferentially direct striatofugal neurons while other data suggested that afferents from the primary motor cortex are mostly associated with indirect striato-GPe neurons (Sidibe and Smith, 1996; Parthasarathy and Graybiel, 1997). The findings obtained in this project further extend the view that excitatory inputs to direct and indirect striatofugal neurons are chemically heterogeneous and possibly arise from different thalamic and cortical sources. More importantly, our findings suggest that the glutamate released at axo-spinous synapses on indirect striatofugal neurons, but not those on direct striatofugal neurons, is tightly regulated by kainate receptors activation. Future electrophysiological and pharmacological studies are essential to determine the

effects of kainate receptors activation on glutamate-induced excitation at these synapses. In other brain regions, pre-synaptic kainate receptors have facilitatory or inhibitory effects on neurotransmitter release (Lerma et al., 1997; Frerking and Nicoll, 2000). (2) They support the hypothesis that one of the potential mechanism by which indirect striatofugal neurons are more sensitive than direct striatofugal neurons in HD might be their differential degree of glutamatergic innervation by kainate-containing terminals. If, indeed, the GluR6 subunit is abnormally regulated in some HD patients, some of the kainate receptors expressed in glutamatergic terminals in contact with spines of striato-GPe neurons may not function normally, thereby, lead to an abnormal regulation of glutamate release at these synapses which eventually result in excitotoxic cell death.

## II. Hypothesis 5-Specific Aim 6-Progress

Over the past year, we also undertook experiments to address specific aim #6. The main objective of this specific aim is to elucidate the relationships between the glial glutamate transporter, GLT-1, and kainate-containing glutamatergic terminals. The rationale underlying

this particular series of experiments is that GLT-1 is known as the most important glutamate transporter to control the degree of glutamate reuptake and extrasynaptic diffusion of neurotransmitter (Danbolt, 2001). In other words, knowing the distribution and density of glutamate transporters in relation to glutamate receptors provide a solid substrate to better characterize the mechanism of activation and potential sources of glutamate to activate these receptors. For instance, if the terminals that express pre-synaptic kainate

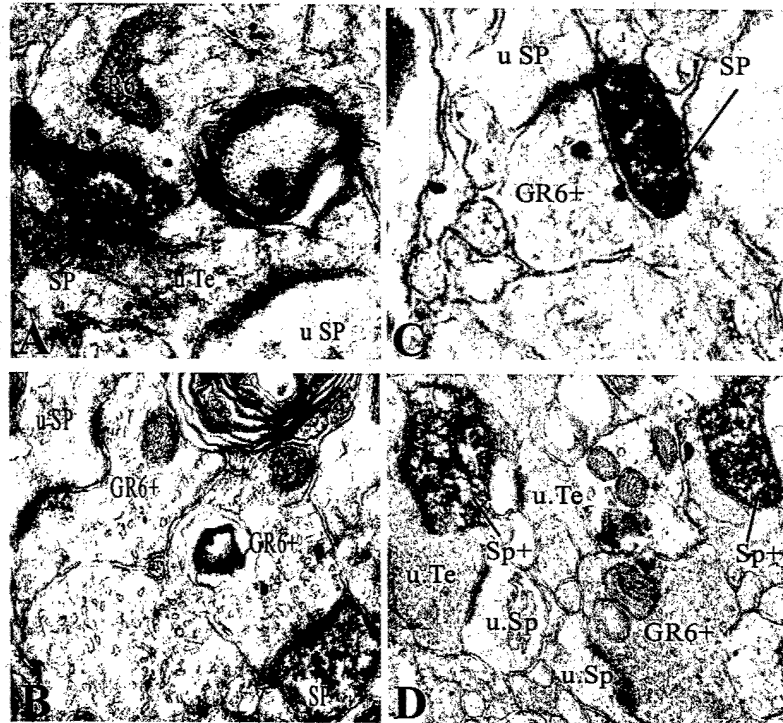

**Figure 2: (A,B) GR6 (+) terminals in contact with retrogradely labelled spines of striato-GPe neurons. (C,D) GR6+ terminals form synapses preferentially with unlabelled spines after BDA injection in GPI.**

receptors are tightly surrounded by processes of astrocytes that contain GLT-1, it strongly suggests that the most likely source of glutamate to activate these

receptors is the neurotransmitter released by the parent terminals. On the other hand, if the kainate-containing terminals are not intimately related to GLT-1 processes, it may suggest that the extrasynaptic diffusion of glutamate from neighboring synapses may also have access to pre-synaptic kainate receptors, as was found for other glutamate receptor subtypes in various brain regions (Rusakov and Kullmann, 1998; Brasnjo and Otis, 2001; Danbolt, 2001). It is noteworthy that glutamate spillover and the importance of glutamate transporters in regulating this phenomenon have been topics of major interest in the field of glutamatergic neurotransmission over the past few years (Asztely et al., 1997; Barbour and Hausser, 1997; Brasnjo and Otis, 2001; Arnth-Jensen et al., 2002).

We used various single and double pre- and post-embedding immunogold approaches to address this issue. As a first series of experiments we simply studied the localization of GLT-1 in the monkey striatum using immunoperoxidase. As expected, GLT-1 immunoreactivity was strongly expressed in astrocytes and their processes which, in many cases, tightly surrounded putative glutamatergic axon terminals (Fig. 3A,C). In addition, we found that a subpopulation of axon terminals forming asymmetric synapses displayed GLT-1 immunolabeling (Fig. 3A,B). Although GLT-1 was originally characterized as a glial transporter, recent data showed its expression in axon terminals in various brain regions suggesting that it may also act as a neuronal transporter in some systems (Schmitt et al., 1996; Mennerick et al., 1998). Our findings indicate that such may, indeed, be the case in the striatum. It is worth noting that our data are consistent with a

recent study showing that lesions of the cerebral cortex results in a significant decrease of glutamate uptake activity in the rat striatum (Lievens et al., 2000). Based on these observations, we tested the possibility that some of these GLT-1-immunoreactive terminals may also express pre-synaptic kainate receptor subunits.



**Figure 3: (A) A GLT-1-positive terminal (GLT-1+) and glial processes in the monkey putamen, (B) Putative glutamatergic terminal immunoreactive for both GLT-1 (peroxidase) and GluR6/7 (gold) in the striatum, (C) Post-embedding immunogold localization of GLT-1 immunoreactivity in a glial process that tightly surrounds a glutamatergic axon terminal the caudate nucleus**

To do so, we used a double pre-embedding immunolabeling approach that combines immunogold (to reveal GluR6) and immunoperoxidase (to reveal GLT-1). So far, striatal tissue from two rhesus monkeys has been processed according to this double labelling procedure. Our

preliminary data demonstrate that more than 60% of kainate receptor-containing terminals express GLT-1 in the caudate nucleus and putamen (Fig. 3B). This suggests that glutamate reuptake at the terminal level may serve as a source of activation for pre-synaptic kainate receptors in the monkey striatum. To complete this series of experiments we will perform this double

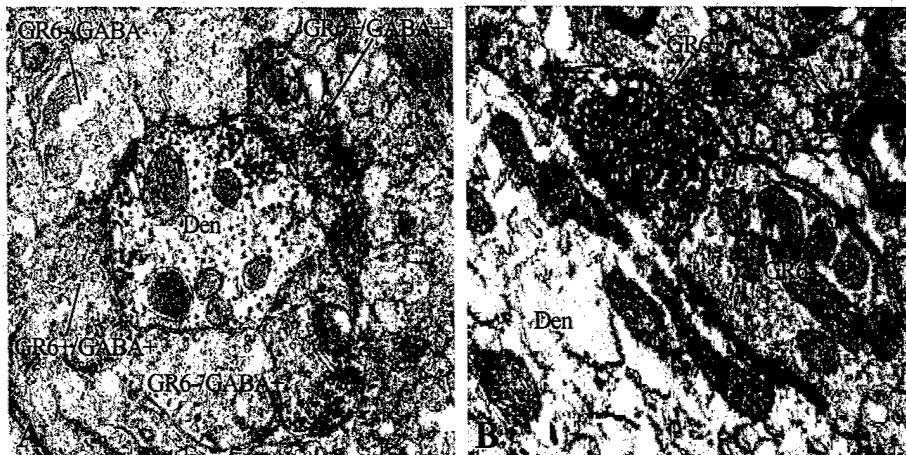

**Figure 4: (A) Post-embedding immunogold localization of GABA combined with GluR6/7 immunoreactivity in the monkey GPI. Boutons that co-express GluR6/7 and GABA are shown (GR6+/GABA+). (B) A GluR 6/7-containing bouton forming an asymmetric synapse in the monkey GPe.**

labelling experiment in the striatum of one more monkey. Then, we will undertake the last part of this project, which will aim at comparing the relative distribution and density of GLT-1-containing glial processes in relation to terminals that express or not pre-synaptic kainate

receptors. Double pre- and post-embedding immunogold procedures will be used to address this issue.

The importance of these studies in our understanding of HD pathophysiology is that glutamate reuptake is affected in the striatum of HD patients (Cross et al., 1986; Arzberger et al., 1997). If these transporters tightly regulate the diffusion of glutamate that binds to pre-synaptic kainate receptors, one may therefore hypothesize that their up- or down-regulation in the striatum of HD patients may affect the function and regulation of pre-synaptic kainate receptors. Therefore, our goal is to provide an anatomical substrate that will set the stage for further functional studies of the role of glutamate transporters regulation in the control of pre-synaptic kainate receptors activation. Our data will also serve as a basis for future studies of glutamate transporters localization and functions in the striatum of animal models of HD.

### **III. Additional Studies- Pre-synaptic Kainate Receptors in the Globus Pallidus**

During the course of these studies, we noticed that other basal ganglia nuclei, including both segments of the globus pallidus, were enriched in GluR6/7 immunoreactivity. At the light microscopic level, neuronal cell bodies and the neuropil of the internal (GPi) and external (GPe) pallidum displayed strong immunolabelling. In order to better characterize the exact localization of kainate receptors in the monkey pallidum, we undertook an electron microscopic immunoperoxidase study of GluR6/7 immunoreactivity in the GPe and GPi of three rhesus monkeys. The main findings of this study is that kainate receptors are strongly expressed pre- and post-synaptically in both pallidal segments (Fig. 4). At the pre-synaptic level, both GABAergic and non-GABAergic terminals display GluR6/7 immunoreactivity (Fig. 4A,B), which suggest that pre-synaptic kainate receptors can act as auto- or heteroreceptors in the monkey pallidum. These observations serve as a basis for future electrophysiological studies of the role of pre-synaptic kainate receptors in regulating excitatory and inhibitory transmission in the globus pallidus. Results of this study will be presented at the next Society for Neuroscience meeting in Orlando (Appendix 7) and a paper is currently in preparation for submission next Fall.

The importance of these data regarding basal ganglia pathophysiology of various movement disorders including HD is the potential development of novel drugs that could selectively target GluR6-containing kainate receptors and modulate glutamatergic and GABAergic neurotransmission in GPe and GPi. It is still premature to speculate about a particular treatment strategy at this point without knowing the exact role pre-synaptic kainate receptors play in this system. Our goal is, therefore, to undertake a series of electrophysiological studies in rat brain slices to elucidate the effects of kainate receptor activation on glutamatergic and GABAergic neurotransmission.

## **KEY RESEARCH ACCOMPLISHMENTS**

The main findings obtained in this project over the past year are summarized as follows:

- Glutamatergic axon terminals that express pre-synaptic kainate receptors form synapses preferentially with striatal neurons that project to GPe ("indirect" striatofugal neurons)

compared to GPi ("direct" striatofugal neurons). These data suggest that a malfunctioning of pre-synaptic kainate receptors may lead to an abnormal regulation of glutamate release at excitatory synapses established preferentially on indirect striatofugal neurons, which may explain why this particular population of striatal projection neurons is more sensitive to neurodegeneration than the direct striatofugal neurons in HD.

- A large proportion of axon terminals that express pre-synaptic kainate receptors in the striatum also display immunoreactivity for the glutamate transporter GLT-1. These data suggest that a change in glutamate reuptake, as proposed in various diseases including HD, may lead to abnormal activation of pre-synaptic kainate receptors, thereby, a change in glutamatergic transmission at these synapses. Knowing the excitotoxic nature of glutamate in the CNS, this combination of changes in glutamate reuptake and pre-synaptic kainate receptor functions may ultimately result in cell death of striatal projection neurons in HD.
- Pre-synaptic kainate receptors were found in both GABAergic and non-GABAergic axon terminals in the two segments of the globus pallidus, which suggest that kainate receptors activation is involved in regulating GABAergic and glutamatergic transmission in the pallidum. Knowing that an imbalance in these two systems underlies the pathophysiology of the basal ganglia circuitry in various movement disorder diseases including HD (DeLong, 1990), our observations open up the possibility for the development of novel therapeutic strategies that aim at targeting kainate receptors in basal ganglia diseases. Our findings also set the stage for future electrophysiological studies of kainate receptor functions in the pallidal complex.

## REPORTABLE OUTCOMES

Kieval, J.Z., A. Charara, J.-F. Paré and Y. Smith (2001) Subcellular and subsynaptic localization of pre- and post-synaptic kainate receptor subunits in the monkey striatum. *J. Neurosci.* 21: 8746-8757 (APPENDIX 1).

Smith, Y., A. Charara, M. Paquet, J.Z. Kieval, J.E. Hanson, W.G. Hubert, M. Kuwajima and A.I. Levey (2001) Ionotropic and Metabotropic GABA and Glutamate Receptors in the Primate Basal Ganglia. *J. Chem. Neuroanat.* 22: 13-42 (APPENDIX 2).

Sidibe, M., J.-F. Pare and Y. Smith (2002) Anatomical and functional relationships between intralaminar thalamic nuclei and basal ganglia in monkeys. In "The Basal Ganglia VII", R.L.M. Faull and L. Nicholson (eds). Plenum Press: New York (in press) (APPENDIX 3).

Smith, Y. and A. Charara (2002) Anatomy and synaptic connectivity of the basal ganglia. In Youman's Neurological Surgery, Winn, H.R., K.J. Burchiel and R.A.E. Bakay (eds). Saunders Company: Philadelphia, USA (in press) (APPENDIX 4).

Smith, Y., J.Z. Kieval and A. Charara (2001) Pre- and post-synaptic kainate receptors in the striatum. Proc. 11<sup>th</sup> Neuropharmacology Conf., Abstr 2.06 (APPENDIX 5).

Weeks, J.L., Kane-Jackson, R. and Y. Smith (2001) Kainate receptors in the primate striatum: Relationships with direct and indirect striatofugal neurons. Soc. for Neurosci. 27: 291.9 (APPENDIX 6).

Kane-Jackson, R. and Y. Smith (2002) Pre- and post-synaptic kainate receptors in the monkey globus pallidus. Soc. for Neurosci. 28: 359.16 (APPENDIX 7).

## CONCLUSIONS

Although kainic acid has long been known as a major neuronal excitotoxin, the localization, role and regulation of kainate receptors in the CNS remain very poorly known. The discovery that a mutation of the gene encoding for one of the kainate receptor subunits may be involved in HD combined with the fact that these receptors are strategically located pre-synaptically on glutamatergic terminals in the striatum (Charara et al., 1999) highlight their potential importance in the control of glutamatergic transmission, thereby, excitotoxicity in HD.

Findings obtained so far in this project have revealed very important features regarding the localization of kainate receptors in the monkey striatum. As discussed above, our data provide a solid substrate to further understand kainate receptor functions in the striatum and, more importantly, to better characterize their potential implication in the pathogenesis of HD. We believe that the series of data obtained in this project will set the stage for future studies which will aim at elucidating various critical issues including the exact role of pre-synaptic kainate receptors on glutamatergic neurotransmission in the striatum as well as GABA and glutamate release in the globus pallidus. Another important follow-up to these studies would be to examine the potential regulation of pre- and post-synaptic kainate receptors in the striatum of animal models of HD, particularly in the 3 Nitropropionic acid (3NP) monkey model (Brouillet and Hantraye, 1995; Palfi et al., 1996).

## REFERENCES

- Anwyl, R. (1999) Metabotropic glutamate receptors: Electrophysiological properties and role in plasticity. *Brain Res. Rev.* 29: 83-120.
- Arnth-Jensen, N. et al. (2002) Cooperation between independent hippocampal synapses is controlled by glutamate uptake. *Nature NS* 5: 325-331.
- Arzberger, T. et al. (1997) Changes of NMDA receptor subunit (NR1, NR2B) and glutamate transporter (GLT-1) mRNA expression in Huntington's disease-An in situ hybridization study. *J. Neuropathol. Exp. Neurol.* 56: 440-454.
- Asztely et al. (1997) Extrasynaptic glutamate spillover in the hippocampus: dependence on temperature and the role of active glutamate uptake. *Neuron* 18, 281-293.
- Barbour, B. and M. Hausser (1997) Intersynaptic diffusion of neurotransmitter. *Trends Neurosci.* 20: 377-384.
- Brasnjic, G. and T.S. Otis (2001) Neuronal glutamate transporters control activation of postsynaptic metabotropic glutamate receptors and influence cerebellar long-term depression. *Neuron* 31: 607-616.
- Brouillet, E. and P. Hantraye (1995) Effects of chronic MPTP and 3-nitropropionic acid in nonhuman primates. *Curr. Opin. Neurobiol.* 8: 469-473.
- Charara, A., E. Blankstein and Y. Smith (1999) Presynaptic kainate receptors in the monkey striatum. *Neuroscience* 91: 1195-1200.
- Cross, A.J. et al. (1986) Reduced high-affinity glutamate uptake sites in the brains of patients with Huntington's disease. *Neurosci. Lett.* 67: 198-202.
- Danbolt, N.C. (2001) Glutamate uptake. *Prog. Neurobiol.* 65: 1-105.
- DeLong, M.R. (1990) Primate models of movement disorders of basal ganglia origin. *Trends Neurosci.* 13: 281-285.
- Frerking, M. and R.A. Nicoll (2000) Synaptic kainate receptors. *Curr. Opin. Neurobiol.* 10: 342-351.
- Gerfen, C.R. et al. (1990) D1 and D2 dopamine receptor-regulated gene expression of striatonigral and striatopallidal neurons. *Science* 250: 1429-1432.
- Kamiya, H. (2002) Kainate receptor-dependent presynaptic modulation and plasticity. *Neurosci. Res.* 42: 1-6.

- Lerma, J. et al. (1997) Glutamate receptors of the kainate type and synaptic transmission. *Trends Neurosci.* 20: 9-12.
- Lievens, J.-C. et al. (2000) Differential effects of corticostriatal and thalamostriatal deafferentation on expression of the glutamate transporter GLT1 in the rat striatum. *J. Neurochem.* 74: 909-919.
- McDonald, M.E. et al (1999) Evidence for the GluR6 gene associated with younger onset age of Huntington's disease. *Neurology* 53: 1330-1332.
- Mennerick, S. et al. (1998) Neuronal expression of the glutamate transporter GLT-1 in hippocampal microcultures. *J. Neurosci.* 18: 4490-4499.
- Palfi, S. et al (1996) Chronic 3-nitropropionic acid treatment in baboons replicates the cognitive and motor deficits of Huntington's disease. *J. Neurosci.* 16: 3019-3025.
- Parthasarathy, H.B. and A.M. Graybiel (1997) Cortically driven immediate-early gene expression reflects modular influence of sensorimotor cortex on identified striatal neurons in the squirrel monkey. *J. Neurosci.* 17: 2477-2491.
- Rubinsztein, D.C. et al. (1997) Genotypes at the GluR6 kainate receptor locus are associated with variation in the age of onset of Huntington's disease. *Proc. Natl. Acad. Sci. USA* 94: 3872-3876.
- Rusakov, D.A. and D.M. Kullmann (1998) Extrasynaptic glutamate diffusion in the hippocampus: Ultrastructural constraints, uptake, and receptor activation. *J. Neurosci.* 18: 3158-3170.
- Schmitt, A. et al. (1996) Expression of the glutamate transporter GLT1 in neural cells of the rat central nervous system: Non-radioactive *in situ* hybridization and comparative immunocytochemistry. *Neuroscience* 71: 989-1004.
- Sadikot, A.F. et al. (1992) Efferent connections of the centromedian and parafascicular thalamic nuclei in the squirrel monkey: A light and electron microscopic study of the thalamostriatal projection in relation to striatal heterogeneity. *J. Comp. Neurol.* 320: 228-242.
- Sidibe, M. and Y. Smith (1996) Differential synaptic innervation of striatofugal neurones projecting to the internal or external segments of the globus pallidus by thalamic afferents in the squirrel monkey. *J. Comp. Neurol.* 365: 445-465.
- Smith, Y., A. Charara, J.E. Hanson, M. Paquet and A.I. Levey (2000) GABA-B and group I metabotropic glutamate receptors in the striatopallidal complex in primates. *J. Anatomy* 196: 555-576.
- Vonsattel, J.P.G. and Di Figlia, M. (1998) Huntington Disease. *J. Neuropathol. Exp. Neurol.* 57: 369-384.

## Subcellular and Subsynaptic Localization of Presynaptic and Postsynaptic Kainate Receptor Subunits in the Monkey Striatum

Jeremy Z. Kieval, G. W. Hubert, Ali Charara, Jean-François Paré, and Yoland Smith

Division of Neuroscience, Yerkes Regional Primate Research Center, and Department of Neurology, Emory University, Atlanta, Georgia 30322

The localization and functions of kainate receptors (KARs) in the CNS are still poorly known. In the striatum, GluR6/7 and KA2 immunoreactivity is expressed presynaptically in a subpopulation of glutamatergic terminals and postsynaptically in dendrites and spines. The goal of this study was to further characterize the subcellular and subsynaptic localization of kainate receptor subunits in the monkey striatum. Immunoperoxidase data reveal that the relative abundance of GluR6/7- and KA2-immunoreactive terminals is homogeneous throughout the striatum irrespective of the differential degree of striatal degeneration in Huntington's disease. Pre-embedding and post-embedding immunogold data indicate that >70% of the presynaptic or postsynaptic GluR6/7 and KA2 labeling is expressed intracellularly. In material stained with the post-embedding immunogold method, approximately one-third of plasma membrane-bound gold particles labeling in axon terminals and spines is associated with asymmetric synapses, thereby representing synaptic kainate

receptor subunits. On the other hand, >60% of the plasma-membrane bound labeling is extrasynaptic. Both GluR6/7 and KA2 labeling in glutamatergic terminals often occurs in clusters of gold particles along the membrane of large vesicular organelles located at various distances from the presynaptic grid. Anterograde labeling from the primary motor cortex or the centromedian thalamic nucleus indicate that both corticostriatal and thalamostriatal terminals express presynaptic GluR6/7 and KA2 immunoreactivity in the postcommissural putamen. In conclusion, these data demonstrate that kainate receptors in the striatum display a pattern of subcellular distribution different from other ionotropic glutamate receptor subtypes, but consistent with their metabotropic-like functions recently shown in the hippocampus.

**Key words:** Huntington's disease; excitotoxicity; presynaptic receptor; corticostriatal pathway; thalamostriatal pathway; post-embedding immunogold

Glutamate is the major excitatory neurotransmitter in the CNS. Its activity is mediated by three groups of ionotropic receptors: NMDA, AMPA, and kainate receptors (KARs). Kainate receptors are comprised of five subunits, GluR5, 6, 7, and KA1-2 (Hollmann and Heinemann, 1994). Until a few years ago, the inability to pharmacologically differentiate AMPA from KA receptors had limited the understanding of a distinct functional role of KARs in the CNS. However, the use of novel benzodiazepine compounds (GYKI compounds), which act as selective antagonists of AMPA receptors (Paternain et al., 1995), has provided a means of demonstrating a distinct role of KARs in modulating synaptic transmission. Interestingly, several *in vitro* electrophysiological and pharmacological studies have shown that KARs mediate presynaptic effects on GABAergic and glutamatergic neurotransmission in various brain regions (Clarke et al., 1997; Lerma et al., 1997; Rodriguez-Moreno et al., 1997; Mulle et al., 1998; Rodriguez-Moreno and Lerma, 1998; Chittajallu et al., 1999; Liu et al., 1999; Min et al., 1999; Perkinson and Sihra, 1999; Chergui et al., 2000; Contractor et al., 2000; Frerking and Nicoll, 2000; Kamiya and Ozawa, 2000). Furthermore, the excitotoxic

effects of KAR agonists were found to be greatly reduced in the CA3 region of the rat hippocampus after mossy fiber denervation (Debonnel et al., 1989). Similar results of decreased susceptibility to kainate-induced seizures and cell death have recently been shown in mutant mice knock-outs of the GluR6 gene (Mulle et al., 1998), providing evidence that these excitotoxic effects are produced through the activation of presynaptic KARs.

Huntington's disease (HD) is an autosomal dominant neurodegenerative disorder characterized by a massive death of striatal projection neurons. In >60% of HD patients, increasing length of CAG repeats correlates highly with a decrease in the age of onset of the disease or the extent of striatal degeneration (Persichetti et al., 1994; Aronin et al., 1995; Penney et al., 1997). However, recent findings have reported that the variance in the age of onset of HD could also be attributed to mutations in the gene encoding the GluR6 KAR subunit (Rubinsztein et al., 1997; MacDonald et al., 1999). Injections of kainic acid into the striatum have, indeed, been known to cause cell death in striatal projection neurons, but to have no such effect on axons crossing or terminating in the area (Coyle and Schwarcz, 1976; McGeer and McGeer, 1976). The fact that these neurotoxic effects of kainate in the striatum are attenuated after decortication (McGeer et al., 1978; Biziere and Coyle, 1979), implies that these effects are mediated via cortical terminal glutamate release. In line with these observations, recent findings from our laboratory have demonstrated the presence of KAR immunoreactivity on glutamatergic nerve terminals in the monkey striatum (Charara et al., 1999). To further extend these data and better understand the functions of kainate receptors in the primate striatum, the aim of the present study is to elucidate the

Received Feb. 23, 2001; revised Aug. 6, 2001; accepted Sept. 5, 2001.

This work was supported by a grant from the United States Army and the National Institutes of Health base grant of Yerkes Regional Primate Research Center (RR 00165). We thank Maney Mazloom and James Weeks for technical assistance, Frank Kiernan for photography, and Peggy Plant for clerical work. Thanks are also due to Beth Richardson for her help and advice to use the high pressure freezer.

Correspondence should be addressed to Yoland Smith, Yerkes Regional Primate Research Center, 954 Gatewood Road Northeast, Emory University, Atlanta, GA 30322. E-mail: yolands@rmy.emory.edu.

Copyright © 2001 Society for Neuroscience 0270-6474/01/218746-12\$15.00/0

subcellular and subsynaptic localization of the GluR6/7 and KA2 KAR subunits in the monkey striatum.

The findings presented in this study have been published in abstract form (Kieval et al., 2000).

## MATERIALS AND METHODS

### Animals and preparation of tissue

Four male adult rhesus monkeys and two male adult squirrel monkeys were used in the present study. The two squirrel monkeys were used for tracing studies (see below), whereas the four rhesus monkeys were processed for KAR immunocytochemistry. After deep anesthesia with an overdose of pentobarbital, rhesus monkeys were perfusion-fixed with 500 ml of cold oxygenated Ringer's solution followed by 2 l of fixative containing 4% paraformaldehyde and 0.1–0.75% glutaraldehyde in phosphate buffer (PB; 0.1 M, pH 7.4). The anesthesia and perfusion of the animals were performed in accordance with the *NIH Guide for the Care and Use of Laboratory Animals* (1996) and the Emory University Animal Care and Use Committee. The brains were then cut in 60- $\mu$ m-thick sections with a vibrating microtome and processed for the immunohistochemical localization of GluR6/7 and KA2 at the electron microscopic level. A series of sections were cut at 100  $\mu$ m and processed for the freeze substitution technique and post-embedding immunogold localization of GluR6/7 and KA2 receptor subunits as described below.

### Kainate receptor antisera

Commercially available affinity-purified polyclonal antisera generated against synthetic peptides corresponding to the C terminus of GluR6 (TFNDRRLPGKETMA) (Upstate Biotechnology, Lake Placid, NY) and KA2 (GPTGPRELTHEHE) (Upstate Biotechnology) were used in this study. The specificity of the anti-GluR6 and anti-KA2 antibodies was determined by immunoblots of cell membranes from transfected human embryonic kidney cells (HEK 293 cells) (Petralia et al., 1994; Wenthold et al., 1994). Immunoblot analyses showed that these antibodies label a single band that corresponds to the molecular weight of their respective receptor subunit. However, as a result of the sequence homology at the C terminus between the GluR6 and the GluR7 subunits, the antibody to GluR6 also recognizes the GluR7 subunit to some degree; hence, the term GluR6/7 for this antiserum. To confirm that the sequence of amino acids of the synthetic peptides used to produce these antibodies are not found in other known proteins, we performed a search for amino acid sequence alignment in the basic local alignment search tool (BLAST) database (Altschul et al., 1997), and we found that there was no significant cross-reactivity with any proteins other than the GluR6/7 and KA2 kainate receptor subunits. This search also revealed that the amino acid sequences used are found in GluR6/7 and KA2 subunits of both rats and humans, suggesting that these antibodies should recognize their corresponding antigenic sites in both primates and nonprimates.

The specificity of the two antisera was further confirmed in the present study by the complete lack of labeling in sections of monkey striatum incubated in solutions from which the antisera were replaced by either nonimmune rabbit serum or antiserum that has been preadsorbed with 10  $\mu$ g/ml homologous peptides for 1 hr at room temperature (Fig. 1*B,D*). Immunoblotting was also performed to test the specificity of the GluR6/7 antiserum on monkey striatal tissue (Fig. 2). The Western blot procedure was performed as follows: samples of protein were subjected to SDS-PAGE and transferred by electroblotting onto polyvinylidene fluoride membranes (Invitrogen, Carlsbad, CA). The blots were blocked with 5% nonfat dry milk, 0.1% Tween 20 in Tris-buffered saline (TBS) (20 mM Tris-HCl plus 137 mM NaCl, pH 7.4) at room temperature for 1 hr, and then incubated overnight at 4°C with antibodies raised against the C terminus of the GluR6/7 subunit (0.5  $\mu$ g/ml; Upstate Biotechnology) in blocking buffer. The blots were then rinsed for 20 min in blocking buffer and incubated for 1 hr in horseradish peroxidase-conjugated goat anti-rabbit IgG (Bio-Rad, Hercules, CA), diluted 1:10,000 in blocking buffer. After several washes in TBS, the immunoreactive proteins were visualized with enhanced chemiluminescence (Amersham Pharmacia Biotech, Buckinghamshire, UK). For preadsorption experiments, antibodies were preadsorbed with 10  $\mu$ g/ml homologous peptide for 1 hr at room temperature.

### Electron microscope KAR immunocytochemistry

*Pre-embedding immunoperoxidase.* Sections prepared for pre-embedding immunoperoxidase were pretreated with sodium borohydride (1% in

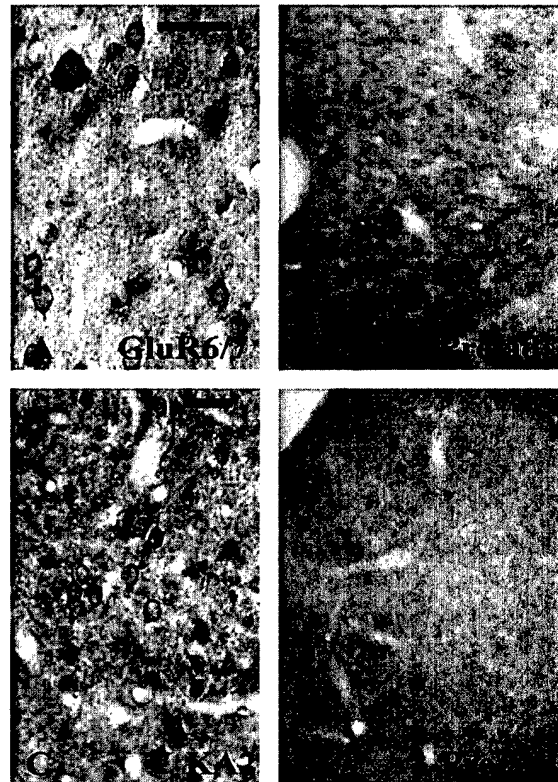

**Figure 1.** Controls for the specificity of GluR6/7 (*A, B*) and KA2 (*C, D*) antisera on monkey striatal tissue. In *B* and *D*, the antisera were preadsorbed with 10  $\mu$ g/ml of homologous peptides for 1 hr before incubation. Scale bars: *A*, 50  $\mu$ m (valid for *B*); *C*, 50  $\mu$ m (valid for *D*).

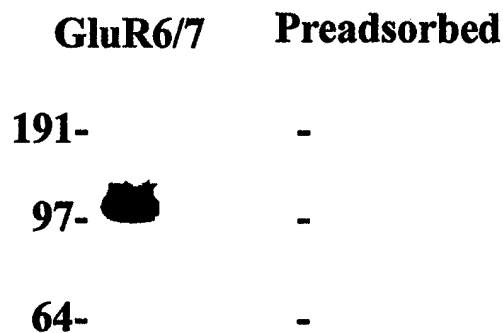

**Figure 2.** Western blot analysis demonstrating the specificity of the GluR6/7 antiserum. The antibodies detected a single band that corresponds to the approximate molecular weights predicted for GluR6 and GluR7 subunits (~118 kDa). Immunoreactivity is completely abolished when antibodies are preadsorbed with the synthetic GluR6/7 peptide 1 hr before immunoblotting. Molecular weight standards are indicated on the left ( $10^3$  molecular weight).

PBS; 0.01 M; pH 7.4) and then cryoprotected in a solution of 25% sucrose and 10% glycerol before being frozen at  $-80^{\circ}\text{C}$  for 20 min. They were then thawed and returned to a graded series of cryoprotectant and PBS. Afterward, sections were preincubated in 10% normal goat serum (NGS) in PBS for 1 hr, followed by incubation for 48 hr at 4°C in rabbit polyclonal antisera (GluR6/7, 7.5  $\mu$ g/ml; KA2, 0.55  $\mu$ g/ml) diluted in PBS supplemented with 1% NGS. After three 10 min washes in PBS, the sections were incubated in biotinylated goat anti-rabbit IgG (1:200; Vector Laboratories, Burlingame, CA) for 90 min at room temperature, which was followed by three 10 min washes in PBS. Incubation in the avidin-biotin-peroxidase complex (ABC; 1:100; Vector Laboratories) (Hsu et al., 1981) subsequently followed for a period of 90 min. After two 10 min washes in PBS and one 10 min wash in TRIS buffer (0.05 M, pH

7.6), the immunostaining was revealed by incubation for 10 min in a solution containing 0.025% 3,3'-diaminobenzidine tetrahydrochloride (DAB; Sigma, St. Louis, MO), 0.01 M imidazole (Fisher Scientific, Atlanta, GA), and 0.006% hydrogen peroxide ( $H_2O_2$ ). The reaction was stopped by repeated washes in PBS.

**Pre-embedding immunogold.** Sections processed for pre-embedding immunogold were prepared as described in previous studies (Hanson and Smith, 1999). In brief, sections were pretreated with sodium borohydride, cryoprotected, and frozen at  $-80^\circ C$  in the same manner as those processed for immunoperoxidase. They were then preincubated in 10% NGS in PBS containing 0.5% bovine serum albumin, 0.05% Tween 20, and 0.1% gelatin (PBS-BSA) for 1 hr. This was followed by an overnight incubation at room temperature in the primary antibody solution diluted as described above. After three 10 min washes in PBS-BSA, the sections were incubated in goat anti-rabbit IgG conjugated to 1.4 nm colloidal gold particles (1:100 in PBS-BSA; Nanogold; Nanoprobes, Stony Brook, NY) for 2 hr at room temperature. After a 5 min wash in PBS-BSA and two 5 min washes in PBS, the sections were post-fixed in 1% glutaraldehyde in PBS for 10 min at room temperature. After washing in PB (0.1 M, pH 7.4) for 5 min, the gold labeling was intensified by using a silver enhancement kit (HQ silver; Nanoprobes) for 5–10 min at room temperature in the dark and stopped by several washes in distilled water.

#### *Anterograde labeling of corticostriatal and thalamostriatal afferents*

Two squirrel monkeys received bilateral iontophoretic injections of biotinylated dextran amine (BDA) either in the primary motor cortex or the centromedian (CM) intralaminar thalamic nucleus. After being intubated and anesthetized with isoflurane, the animals were fixed in a stereotaxic frame, and intracerebral injections of BDA were performed according to procedures described in details in many of our previous studies (Shink et al., 1996; Sidibé and Smith, 1996; Sidibé et al., 1997). In brief, the BDA was injected for 20 min through glass micropipettes with a tip diameter ranging from 20 to 50  $\mu m$  using a 6  $\mu A$  positive current delivered at a 7 sec ON/7 sec OFF cycle. Two injection sites along a single penetration were made in CM, whereas a total of 10 injection sites along eight penetrations were made in the cerebral cortex. The depth of anesthesia was monitored throughout the surgery by measuring heart rate, blood oxygen level, and toe pinch reflex. After surgery, animals received systemic injections of analgesic for 48 hr. The surgical and anesthesia procedures used in these experiments are consistent with those of the National Institute of Health and approved by the Institutional Animal Care and Use Committee of Emory University. After 7–10 d survival, the animals were deeply anesthetized with sodium pentobarbital and perfused transcardially as described above for rhesus monkeys, except that the volumes of Ringer's and fixative were reduced to 350 ml and 1 l, respectively.

#### *BDA histochemistry combined with KAR immunocytochemistry*

The BDA was revealed with the ABC method as described in previous studies. In brief, after sodium borohydride treatment, cryoprotection, and  $-80^\circ C$  freezing, sections were washed in PBS and incubated overnight at room temperature in standard ABC complex (1:100 dilution). The peroxidase bound to the BDA was then localized with DAB as described above for KAR immunoperoxidase localization. Once the BDA has been revealed, striatal sections that contained large amount of anterogradely labeled fibers were processed for the pre-embedding immunogold localization of GluR6/7 and KA2 as described above. Double-labeled sections were then prepared for electron microscopy.

As controls, a series of sections were processed to reveal BDA followed by incubation in solution containing nonimmune rabbit serum rather than KAR antisera.

**Preparation for electron microscopy.** All sections prepared for electron microscopy were washed in PB (0.1 M, pH 7.4) before being post-fixed in osmium tetroxide (1% solution in PB) for 10–20 min. They were then washed five times (5 min each) in PB and dehydrated in a graded series of alcohol and propylene oxide. Uranyl acetate was added to the 70% ethanol to improve the contrast in the electron microscope. The sections were then embedded in resin (Durcupan, ACM; Fluka, Buchs, Switzerland) on microscope slides and put in the oven for 48 hr at  $60^\circ C$ . After examination in the light microscope, areas of interest in the striatum were cut out from the slides and glued on top of resin blocks with cyanoacrylate glue. Ultrathin 60-nm-thick sections were cut on a Leica (Nussloch, Germany) UCT ultramicrotome and collected on pioloform-coated, sin-

gle slot copper or gold grids. Some sections were stained with lead citrate (Reynolds, 1963) and examined with a Zeiss EM10C electron microscope.

**High-pressure freezing, freeze substitution, and post-embedding immunogold technique for KAR localization.** Tissue from the putamen and the head of the caudate nucleus from three rhesus monkeys were used in this study. After cryoprotection, small areas of 2 mm in diameter were taken from 100- $\mu m$ -thick striatal sections and placed between two aluminum planchettes that were then instantly frozen in liquid nitrogen using a high-pressure freezer (Balzers HPM 010). Sections were stored in liquid nitrogen until transfer into a freeze substitution apparatus (Bal-Tec FSU 010) whereby the temperature was increased from  $-90$  to  $-45^\circ C$  in four major steps over a period of 30 hr. The specimens were freeze-substituted in 0.5% uranyl acetate dissolved in methanol and then embedded in Lowicryl HM-20 ( $-45^\circ C$ ) in a low temperature polymerization unit (Bal-Tec LTPU 010) for 48 hr. Ultrathin 80-nm-thick sections were cut on a Leica UCT ultramicrotome and collected on pioloform-coated, 400 mesh gold grids.

Sections of freeze-substituted material were first treated in a saturated solution of sodium hydroxide in 100% ethanol (<1 sec.). After being washed in Tris-buffered saline containing 0.01% Triton X-100 (TBS-T), they were incubated for 10 min on drops of 0.1% sodium borohydride and 0.05 M glycine diluted in TBS-T. They were then washed in TBS-T and preincubated for 30 min in TBS-T containing 10% normal serum and 2% human serum albumin (HSA) before being incubated overnight at room temperature with the GluR6/7 (15  $\mu g/ml$ ) and KA2 (5.5  $\mu g/ml$ ) antisera diluted in a solution of TBS-T containing 1% normal serum and 2% HSA. After many washes in TBS-T, the grids were incubated for 90 min in the 10 nm gold-conjugated secondary antibodies (1:180; BBInternational) diluted in TBS-T containing 1% normal serum and 2% HSA. Grids were washed in ultrapure water and contrasted in a 1% aqueous solution of uranyl acetate for 90 min. The grids were then stained with lead citrate (Reynolds, 1963) before observation.

Control sections were incubated in solutions from which the primary antisera were replaced by 1% nonimmune rabbit serum, whereas the rest of the protocol remained the same as described above.

#### *Analysis of material*

**Immunoperoxidase data.** To estimate the relative abundance of GluR6/7- and KA2-immunoreactive elements in different striatal regions, a series of 50 electron micrographs were taken at 16,500 $\times$  from randomly chosen areas of the tail and body of the caudate nucleus, the putamen, and the nucleus accumbens in three monkeys. These micrographs covered a total surface of 7148  $\mu m^2$  of striatal tissue in each animal. All micrographs were taken from tissue on the surface of the blocks where the intensity of labeling was optimal. In each micrograph, immunoreactive elements were categorized as unmyelinated axons, terminals, spines, or small and large dendrites based on the following ultrastructural features. The unmyelinated axons were distinguished by their small diameter (0.1–0.2  $\mu m$ ), regular contours, lack of synaptic inputs, and presence of microtubules, whereas axon terminals contained synaptic vesicles and did not receive synaptic inputs. The heads of dendritic spines were recognized by their electron lucent and bulbous appearance, lack of mitochondria, and absence of microtubules. They also frequently received asymmetric synaptic inputs. Finally, most dendrites were easily distinguishable from other neuronal elements by their large size and enrichment in mitochondria and microtubules. Elements that could not be categorized according to these ultrastructural features were not considered in the analysis. The mean percentage of labeled elements in each category was then calculated, and  $\chi^2$  tests were performed to compare the relative abundance of immunoreactive terminals in the different striatal regions.

**Pre-embedding immunogold data.** In tissue immunostained with the pre-embedding immunogold technique, the proportion of gold particle labeling associated with the plasma membrane and intracellular compartments was calculated from a series of 200 electron micrographs taken at 25,000 $\times$  in the putamen and the head of the caudate nucleus in three monkeys. These micrographs covered a total surface of 2843  $\mu m^2$  of striatal tissue. To avoid false-positive data generated by light background staining, an element had to contain, at least, three gold particles to be considered immunoreactive. The total number of gold particles in each immunoreactive element encountered in these micrographs was then calculated and categorized as intracellular or bound to the plasma membrane. Taking into consideration the size of primary and secondary antibodies, the maximum distance between the 1.4 nm gold particle and the epitope would be  $\sim 17$  nm (Blackstad et al., 1990). Based on this

criterion, presynaptic or postsynaptic gold particle labeling was categorized as plasma membrane-bound if it was found inside an area not further than 16 nm plus radius of gold particles from the presynaptic or postsynaptic plasma membranes, respectively. All other gold particles were categorized as “intracellular”. To avoid problems in categorizing the membrane-bound gold particles, only those elements that displayed good ultrastructural preservation with well preserved plasma membrane were considered.

**Post-embedding immunogold data.** This method was used to characterize the subsynaptic localization of GluR6/7 and KA2 labeling. The advantages of this approach over the pre-embedding immunogold technique to label synaptic receptors have been discussed in details in previous studies (Lujan et al., 1996; Ottersen and Landsend, 1997). In brief, the fact that the entire cut length of the plasma membrane is uniformly exposed to the antibodies increases the accessibility to the antigenic sites, which provides a condition for quantitative analysis of synaptic receptor localization. Quantitative measurements were made from a series of 100 electron micrographs taken at 31,500 $\times$  from putamen and caudate tissue immunostained with GluR6/7 and KA2 by the post-embedding immunogold method. Because the quality of ultrastructural preservation of post-embedding immunostained tissue on the same grid is variable, we chose immunostained areas where the preservation was optimal for this analysis. To verify whether the pattern of distribution of immunogold labeling was the same as that found with the pre-embedding immunogold technique, we counted the total number of gold particles in a series of labeled terminals and spines and determined the proportion that were bound to the plasma membrane or intracellular. Furthermore, we categorized the plasma membrane-bound gold particles as “synaptic” or “extrasynaptic” based on their respective localization to synapses. A gold particle was categorized synaptic if it was located inside an area not further than 21 nm (antibody bridges, 16 nm; radius of 10 nm gold particles, 5 nm) from the presynaptic or postsynaptic plasma membrane (Matsubara et al., 1996; Valtchanoff and Weinberg, 2001; Nyiri et al., 2001). All other plasma membrane-bound gold particles were put in the extrasynaptic category. We used an arbitrary criterion that an element had to contain at least three gold particles or more to be considered immunoreactive.

To verify whether the distribution of presynaptic labeling displayed any relationship with the synaptic active zones, a series of immunostained terminals for GluR6/7 or KA2 were randomly selected for measurement of the shortest distance of individual gold particles from the presynaptic plasma membrane. To do so, we measured the distance that separated any gold particles bound to vesicular organelles from the closest part of the presynaptic membrane.

**Anterograde labeling and pre-embedding immunogold labeling.** Five blocks of striatal tissue (three for CM labeling, two for M1 labeling) immunostained for GluR6/7 or KA2 and BDA were chosen for this analysis. In the electron microscope, sections from the surface of the blocks were scanned for the presence of BDA-labeled terminals. Once such boutons were found, they were photographed at low (12,500 $\times$ ) and high (31,500 $\times$ ) magnification and categorized as double labeled if they contained three gold particles or more. To avoid false-negative data because of the poor penetration of the gold-conjugated secondary antibodies in tissue, only those BDA-containing terminals that were found in the vicinity of other non-BDA-labeled KAR-immunoreactive boutons were considered in this analysis.

## RESULTS

### Tests for antibody specificity

As previously shown (Charara et al., 1999), both GluR6/7 and KA2 immunoreactivities were found in numerous neuronal perikarya that displayed morphological features of both medium-sized projection neurons and large interneurons throughout the monkey striatum (Fig. 1*A,C*). After preadsorption of either antisera with homologous peptides, the striatum was completely devoid of immunostaining (Fig. 1*B,D*). Similar results were obtained after omission of the two primary antisera from the incubation solutions. Furthermore, a single band of labeling that corresponds to the molecular weight of GluR6 and GluR7 (Wenthold et al., 1994) was found in Western blots analysis of monkey striatum (Fig. 2). This band was completely abolished after preadsorption of the antiserum with homologous peptides (Fig. 2).

### Relative distribution of GluR6/7 and KA2-immunoreactive elements in the striatum

Tissue from three rhesus monkeys was processed for immunoperoxidase to characterize the general distribution of GluR6/7 and KA2 immunoreactivity in different striatal regions. The goal of this first series of experiments was to determine whether the relative abundance of kainate receptor subunit-immunoreactive glutamatergic terminals correlate with the sensitivity of the different striatal regions to neurodegeneration in HD (Vonsattel and DiFiglia, 1998). To do so, we characterized the nature of labeled elements in striatal areas known to be more or less sensitive to neurodegeneration in HD. The tail and body of the caudate nucleus as well as the dorsal putamen were chosen as sensitive areas, whereas the nucleus accumbens served as the least sensitive region (Vonsattel and DiFiglia, 1998). In all striatal regions, the pattern of distribution and intensity of immunoreactivity for the two antibodies was consistent with previous data from our laboratory (Charara et al., 1999). KAR immunoreactivity was expressed presynaptically in small unmyelinated axons and axon terminals forming asymmetric axospinous and axodendritic synapses. The postsynaptic labeling was found predominantly in small dendrites, whereas labeled spines were much less abundant (Fig. 3). Both medium-sized and large neuronal perikarya also displayed light patchy immunoreactivity (data not shown; Charara et al., 1999). Overall, 20–40% of GluR6/7-containing striatal elements were axon terminals, whereas the proportion of KA2-immunoreactive boutons ranged from 10 to 15% (Fig. 3). Although there was a slight variation in the relative abundance of labeled terminals among the four striatal regions examined, these changes were not significantly different, which indicates that presynaptic KARs are homogeneously distributed throughout the striatum irrespective of the degree of sensitivity to degeneration in HD.

### Subcellular localization of kainate receptor subunit immunoreactivity

#### Pre-embedding immunogold

Because of the poor spatial resolution of the immunoperoxidase deposit, this approach is not suitable to analyze the subcellular and subsynaptic localization of receptors. To overcome this problem we used pre-embedding and post-embedding immunogold procedures that allow to determine more precisely the exact localization site of receptors.

Overall, the pattern of pre-embedding immunogold labeling was consistent with that of the immunoperoxidase data, i.e., gold particles were mostly found in dendrites and axon terminals, although light immunoreactivity was occasionally seen in dendritic spines (Figs. 4, 5). In both large and small neuronal perikarya, gold particles were primarily expressed intracellularly in vesicular and tubular intracellular organelles that likely correspond to parts of endoplasmic reticulum and Golgi apparatus, whereas the plasma membrane was almost completely devoid of immunoreactivity (Fig. 4). To study the subcellular localization of KARs, randomly selected fields of immunoreactive elements were photographed in the putamen and the caudate nucleus of three monkeys. The gold particles were then counted and categorized as intracellular or plasma membrane-bound according to criteria described in Materials and Methods. One of the striking features that characterized the localization of KAR subunit immunoreactivity was that >70% of GluR6/7 and KA2 labeling was expressed intracellularly in all labeled elements (Figs. 4, 5, Table 1). In terminals, most gold particles were homogeneously distrib-

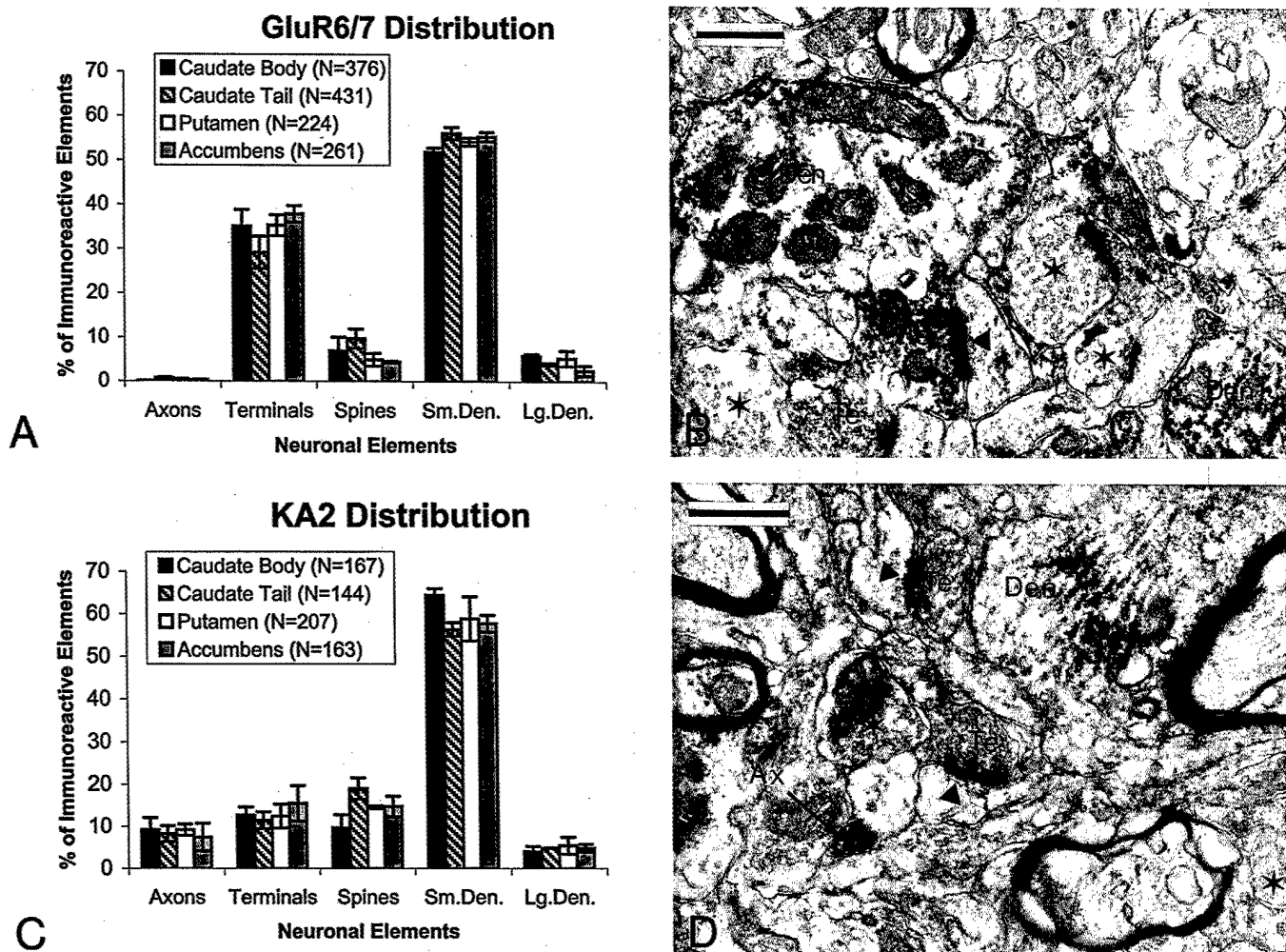

**Figure 3.** Relative distribution of GluR6/7 and KA2 immunoreactivity in different striatal regions. *A*, Histogram showing the relative proportion of neuronal elements immunoreactive for GluR6/7 in different striatal regions. *B*, GluR6/7-immunoreactive elements in the body of the caudate nucleus. Note the presence of labeled terminals (*Te*) forming asymmetric synapses (*arrowheads*) and immunoreactive dendrites (*Den*). The *asterisks* indicate unlabeled boutons. *C*, Histogram showing the relative distribution of neuronal elements immunoreactive for KA2 in different striatal regions. *D*, KA2-containing elements in the body of the caudate nucleus. Two immunoreactive terminals (*Te*), a labeled dendrite (*Den*), and an unmyelinated axon (*Ax*) are shown. The *asterisks* indicate unlabeled boutons. Statistical analysis revealed no significant difference in the relative abundance of GluR6/7 or KA2-containing elements among the different striatal regions ( $\chi^2$ ;  $p < 0.001$ ). Scale bars, 0.5  $\mu$ m.

uted over synaptic vesicles, although dense aggregates of three or more particles were occasionally seen (Fig. 5). Because of the large size of silver-intensified gold particles, the exact localization site of presynaptic labeling was difficult to ascertain. Similarly, the ultrastructural preservation of intracellular organelles in dendrites and spines was not good enough to determine the exact binding site of intracellular postsynaptic gold labeling (Fig. 5).

#### Post-embedding immunogold

Because of the large size of silver-intensified gold particles and poor penetration of gold-conjugated antibodies through thick sections, the pre-embedding immunogold technique provides limited information on the quantitative distribution of subsynaptic antigenic sites. To gain a higher level of spatial resolution and quantitative estimates of the relative distribution of GluR6/7 and KA2 receptor subunit immunoreactivity at the synaptic level, the freeze-substitution post-embedding immunogold technique was performed on striatal tissue. Overall, the distribution of labeling was consistent with results obtained with the pre-embedding immunogold and immunoperoxidase methods (Fig. 6), i.e., gold

particles were seen over axon terminals forming asymmetric synapses, unmyelinated axons, as well as postsynaptic dendrites and spines. In contrast, terminals forming symmetric synapses were completely devoid of labeling. To further ascertain that most of the GluR6/7 and KA2 immunoreactivity was expressed intracellularly, as revealed by the pre-embedding immunogold technique (Table 1), we quantified the density of post-embedding immunogold labeling associated with intracellular elements versus the plasma membrane in a series of spines and axon terminals with good ultrastructural preservation in GluR6/7- and KA2-immunostained material (Table 1). These data revealed that more than two-thirds of both presynaptic and postsynaptic GluR6/7 or KA2 labeling is expressed intracellularly in the monkey striatum (Table 1). However, a main difference between data obtained with the pre-embedding and post-embedding methods relates to the density of synaptic labeling for GluR6/7 and KA2. Although very few gold particles were associated with synapses in material prepared with the pre-embedding immunogold technique (Figs. 4, 5), 30–40% of post-embedding immunogold label-

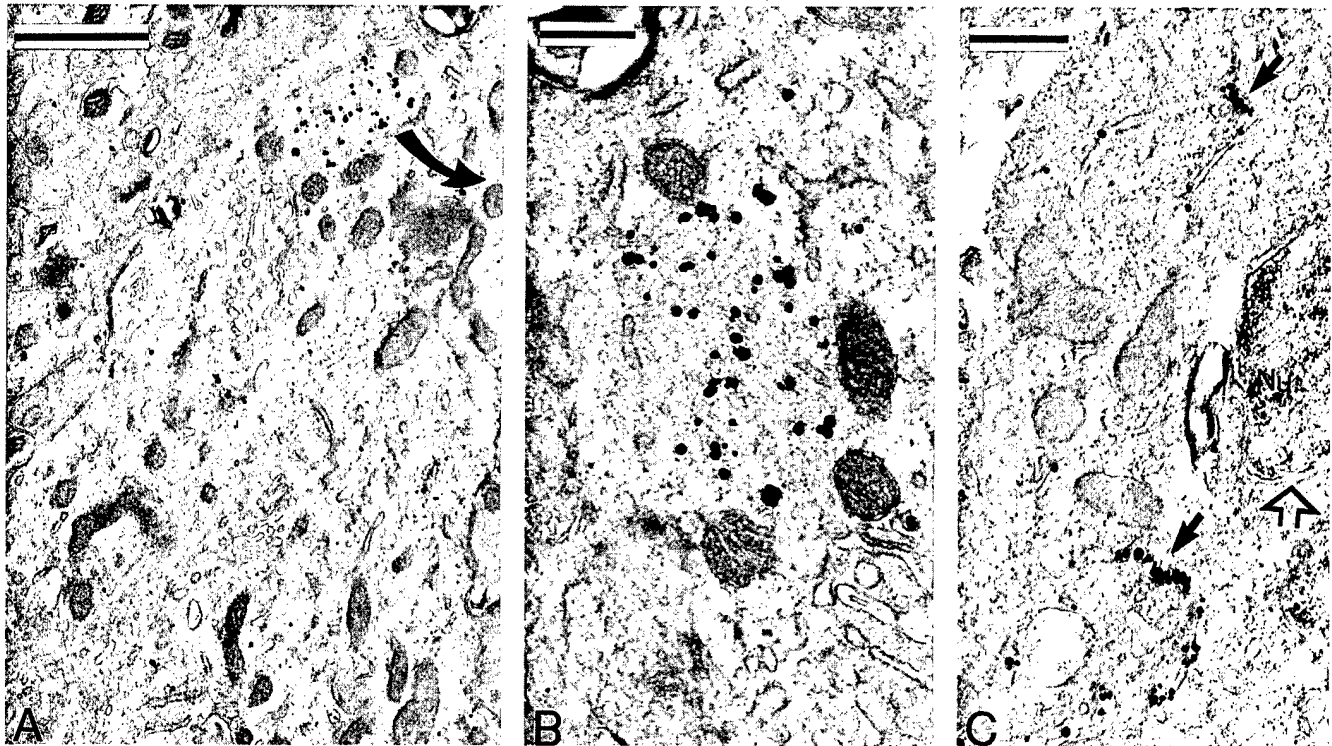

**Figure 4.** GluR6/7 and KA2 immunoreactivity in neuronal perikarya. *A*, A GluR6/7-containing neuronal perikaryon in the putamen. *B*, High magnification of gold particles labeling associated with the endoplasmic reticulum (ER) in this cell body. *C*, KA2 immunoreactivity in Golgi or ER-like tubular organelles in a neuronal perikaryon (arrows) of an interneuron (invaginated nuclear membrane; open arrow). Nu, Nucleus. Scale bars: *A*, 1.0  $\mu\text{m}$ ; *B*, 0.25  $\mu\text{m}$ ; *C*, 0.5  $\mu\text{m}$ .

**Table 1.** Relative distribution of intracellular versus plasma membrane-bound immunogold particle labeling for GluR6/7 and KA2 as revealed by pre-embedding and post-embedding immunogold method

KAR subunits/ neuronal elements	% Intracellular/plasma membrane-bound		
	Spines	Terminals	Dendrites
<b>GluR6/7</b>			
Pre-embedding	71/29 ( $n = 237$ )	74/26 ( $n = 526$ )	78/22 (758)
Post-embedding	76/24 ( $n = 99$ )	81/19 ( $n = 168$ )	—
<b>KA2</b>			
Pre-embedding	76/24 ( $n = 144$ )	77/23 ( $n = 97$ )	75/25 ( $n = 492$ )
Post-embedding	75/25 ( $n = 93$ )	73/27 ( $n = 182$ )	—

Measurements were made from: (1) pre-embedding material, GluR6/7: 58 spines, 88 terminals, 86 dendrites; KA2: 54 spines, 22 terminals, 82 dendrites. (2) Post-embedding material, GluR6/7: 15 spines, 20 terminals; KA2: 15 spines, 20 terminals. Dendrites were not analyzed in the postembedding material.  $N$  = Total number of gold particles.

ing in spines and 20–30% of labeling in terminals was considered synaptic (Table 2). This difference in synaptic labeling between the pre-embedding and post-embedding immunogold methods has been previously described for other types of glutamate and GABA-A receptors (Baude et al., 1993; Nusser et al., 1995a,b). The poor penetration of gold-conjugated secondary antibodies through thick sections likely represents the main limiting factor of the pre-embedding immunogold method to label synaptic receptors.

As mentioned above, subsets of axon terminals forming asymmetric synapses display strong immunoreactivity for KAR subunits which, for the most part, was found to be expressed intracellularly over synaptic vesicles. The post-embedding immunogold method allowed to better characterize this presynaptic labeling and revealed that the majority of gold particles in terminal boutons were often clustered along the membrane of large vesicular organelles that were randomly distributed in the

terminal (Fig. 6*D,F*). In addition, clusters of gold particles were occasionally seen in the presynaptic grid of asymmetric synapses (Fig. 6*B,E*).

To verify the relationships between presynaptic KARs and the synaptic release sites of glutamate, we measured the shortest distance between GluR6/7 and KA2 presynaptic immunogold particles bound to vesicular organelles and the synaptic active zone in 15 immunoreactive axon terminals immunostained with each antibodies (Fig. 7). These measurements indicate that both KAR subtypes display a wide range of distribution in relation to asymmetric synapses; some gold particles being found right at the active zones (Figs. 6*B,E*, 7) others being located as far as 1.0  $\mu\text{m}$  away from the synaptic junctions (Figs. 6*D,F*, 7). Control grids were devoid of labeling except for a few scattered gold particles.

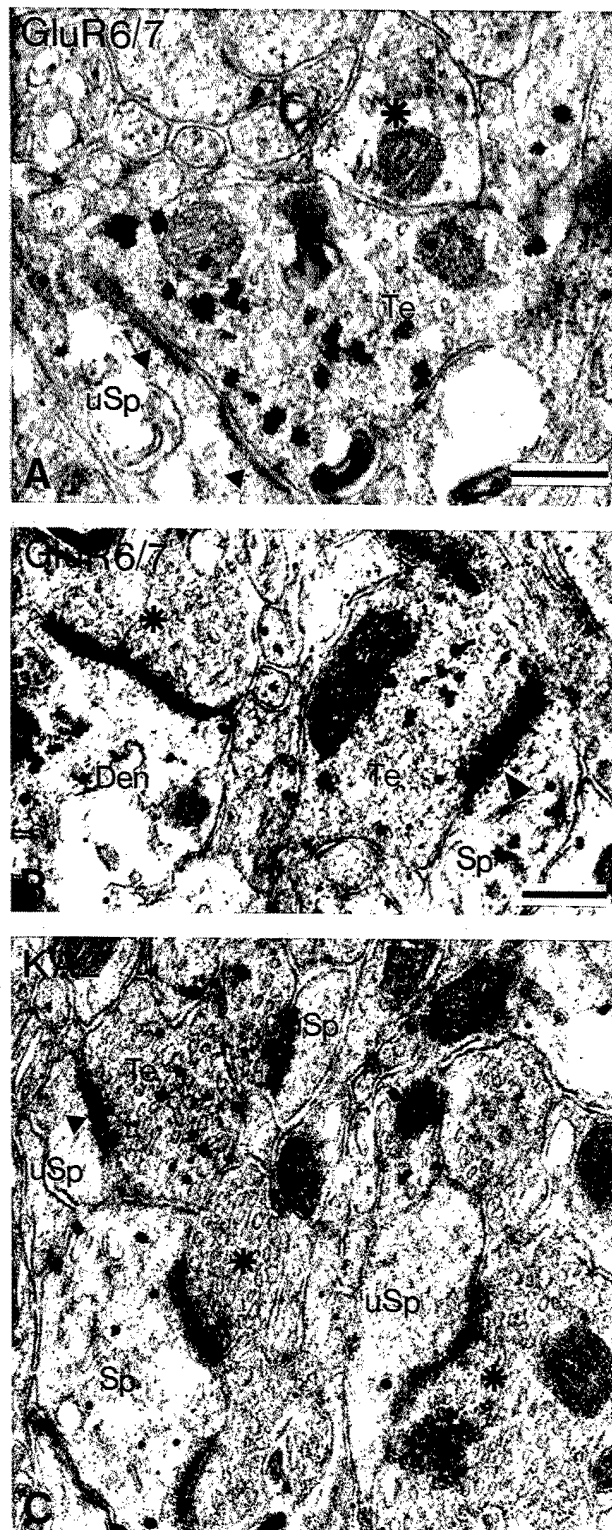

**Figure 5.** GluR6/7-immunoreactive (*A, B*) and KA2-immunoreactive (*C*) elements in the striatum as revealed with the silver-intensified pre-embedding immunogold method. *A, B*, GluR6/7-containing axon terminals (*Te*) forming asymmetric axospinous synapses (*arrowheads*) in the caudate nucleus. Nonimmunoreactive terminals (*\**) and unlabeled spines (*uSp*) are shown in the same region. Labeled dendrites (*Den*) and spines (*Sp*) are indicated. *C*, A KA2-immunoreactive terminal (*Te*) in the putamen. Nonimmunoreactive boutons (*\**) and spines (*uSp*) are shown in the same field. Note that most gold particles in axon terminals, dendrites (*Den*), and spines are located intracellularly. Scale bars: *A*, 0.25  $\mu\text{m}$ ; *B*, 0.25  $\mu\text{m}$  (valid for *C*).

### Sources of immunoreactive terminals

Because both cortical and thalamic afferents provide glutamatergic terminals forming asymmetric synapses in the monkey striatum (Sadikot et al., 1992; Smith et al., 1994), we tested whether KAR subunits were associated with both glutamatergic inputs. Injections of BDA were made in the centromedian nucleus of the thalamus or the primary motor cortex in two squirrel monkeys. The thalamic injection sites were confined to CM with slight contamination of the overlying mediodorsal nucleus and the subparafascicular nucleus, whereas the cortical injections mostly involved the leg and trunk areas of M1 (Fig. 8). As expected based on previous studies (Sadikot et al., 1992; Smith et al., 1994), both injections produced large amount of anterograde labeling in fibers and axon terminals in the postcommissural putamen. In sections double-labeled for GluR6/7 or KA2 and BDA, 30–60% of anterogradely labeled terminals (DAB-stained) displayed KAR subunit immunoreactivity (Table 3). The double-labeled boutons were easily distinguishable from unlabeled terminals in the same field by the coexpression of dense amorphous DAB reaction product (BDA labeling) overlaid by three gold particles or more (KAR labeling) (Fig. 9). Although the relative abundance of KA2-containing terminals was quite similar after thalamic and cortical injections, the proportion of GluR6/7-containing thalamostriatal boutons was higher than corticostriatal terminals (Table 3).

### DISCUSSION

This study provides the first detailed analysis of the subcellular and subsynaptic localization of kainate receptor subunits in the CNS. Four major conclusions can be drawn from our data: (1) kainate receptor-containing glutamatergic terminals are homogeneously distributed throughout the monkey striatum irrespective of the differential sensitivity of striatal regions to Huntington's disease, (2) presynaptic and postsynaptic kainate receptor subunits are primarily expressed intracellularly in cell bodies, dendrites, spines and axon terminals throughout the striatum, (3) the majority of presynaptic and postsynaptic plasma membrane-bound immunogold labeling for GluR6/7 and KA2 is found extrasynaptically, although approximately one-third is also associated with asymmetric synapses, and (4) both thalamic and cortical terminals in the sensorimotor striatum express presynaptic KAR subunits. These results will now be discussed in light of previous functional studies of kainate receptors in the CNS and their potential implication in the progressive death of striatal neurons in HD.

### Presynaptic kainate receptors are homogeneously distributed in the striatum

The immunoperoxidase data presented in this study extend previous findings of our laboratory showing that presynaptic kainate receptors are expressed in a subpopulation of putative glutamatergic boutons in the monkey striatum (Charara et al., 1999). In this study we tested the hypothesis that the relative abundance of KAR-containing terminals was greater in areas that are more sensitive to neurodegeneration in HD. It has, indeed, been shown that variation of the GluR6 subunit genotype is correlated with the age on onset of HD that cannot be accounted for by the number of CAG repeats (Rubinsztein et al., 1997; MacDonald et al., 1999). These observations, combined with the fact that some striatal regions are more sensitive than others to neurodegeneration, led us to consider the possibility that this particular pattern of neuronal death might be

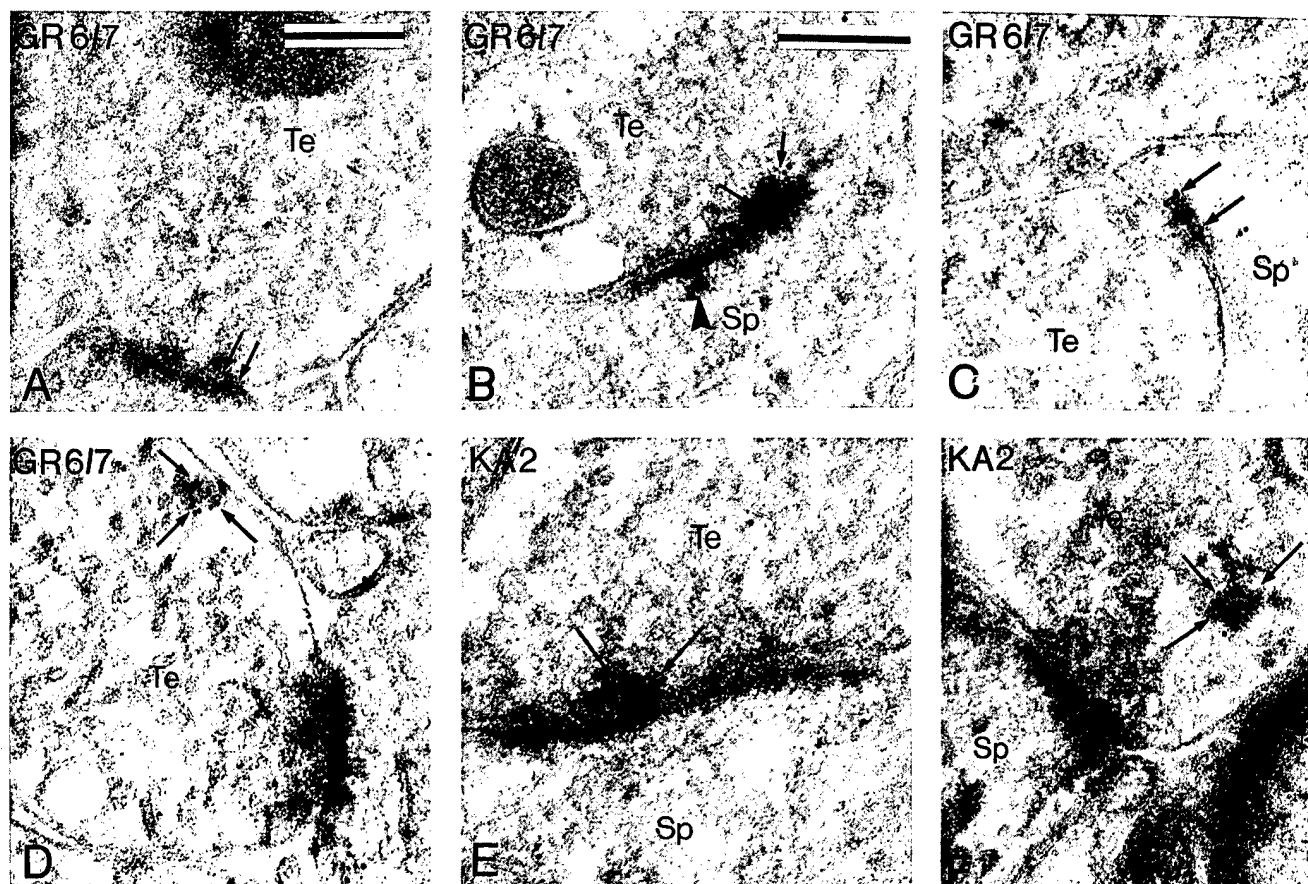

**Figure 6.** Post-embedding immunogold localization of GluR6/7 (*A–D*) and KA2 (*E, F*) immunoreactivity in the striatum. *A, C*, GluR6/7 labeling (*double arrows*) in the active zone of asymmetric axospinous synapses. *B*, Presynaptic and postsynaptic GluR6/7 labeling at an asymmetric axospinous synapse. *D*, Presynaptic GluR6/7 immunoreactivity along the surface of a large vesicular structures (*arrows*) in a terminal forming an asymmetric synapse with a spine. Note that gold particles in the axon terminal are aggregated at the presynaptic grid (*arrows*), whereas the spine labeling is associated with the postsynaptic density of the asymmetric postsynaptic specialization (*arrowhead*). *E*, Dense KA2 labeling (*arrows*) in the presynaptic grid of an asymmetric axospinous synapse. *F*, KA2 labeling (*arrows*) along the surface of a large vesicular organelle in an axon terminal apposed to a spine (*Sp*). Scale bars: *A*, 0.25  $\mu\text{m}$  (valid for *C, D, F*); *B*, 0.25  $\mu\text{m}$  (valid for *E*).

**Table 2. Proportion of synaptic versus extrasynaptic immunogold labeling for kainate receptor subunits at asymmetric synapses in the striatum**

KAR subunits/ neuronal elements	% Synaptic/extrasynaptic gold labeling	
	Spines	Terminals
GluR6/7	38/62 ( $n = 345$ )	22/78 ( $n = 974$ )
KA2	43/57 ( $n = 112$ )	29/71 ( $n = 345$ )

Measurements were made from: GluR6/7, 56 spines; 77 terminals; KA2, 33 spines, 31 terminals.  $N$  = Total number of gold particles.

attributable to a differential distribution of KAR-containing terminals throughout the striatum. We, therefore, hypothesized that areas like the tail of the caudate nucleus, which degenerates first in HD, contains more KAR-positive terminals than the nucleus accumbens, which remains intact in >50% of HD patients (Vonsattel and DiFiglia, 1998). Our data revealed that such is not the case. We did not find any significant difference in the relative abundance of KAR-positive terminals between the tail of the caudate nucleus and other striatal regions. Of course, these data do not rule out the possibility that the malfunctioning of kainate receptors might underlie the pattern of striatal neurodegeneration in HD. However, if such is the case, this

is unlikely to rely on a simple difference in the relative abundance of presynaptic kainate receptors in the different striatal regions. Variation in the GluR6 genotype might rather lead to changes in pharmacological and physiological properties of particular subsets of kainate receptors expressed presynaptically in specific striatal regions.

#### Subcellular localization of kainate receptor subunits

An interesting feature that characterized the subcellular localization of both GluR6/7 and KA2 receptor subunits is their strong intracellular expression. Our data demonstrate that >70% of both presynaptic and postsynaptic KAR subunit immunoreactivity is expressed intracellularly and that almost two-thirds of the plasma membrane-bound KARs are extrasynaptic. This pattern of distribution resembles that of G-protein-coupled metabotropic receptors which, for the most part, are expressed intracellularly or at nonsynaptic sites along plasma membrane (Pasquini et al., 1992; Wang et al., 1997; Bernard et al., 1999; Hanson and Smith, 1999; Smith et al., 2000, 2001). Interestingly, both the presynaptic and postsynaptic effects of kainate receptors are consistent with those of metabotropic glutamate receptor functions (for review, see Conn and Pin, 1997; Anwyl, 1999; Cartmell and Schoepp, 2000). For instance, kainate receptors mediate slow postsynaptic cur-

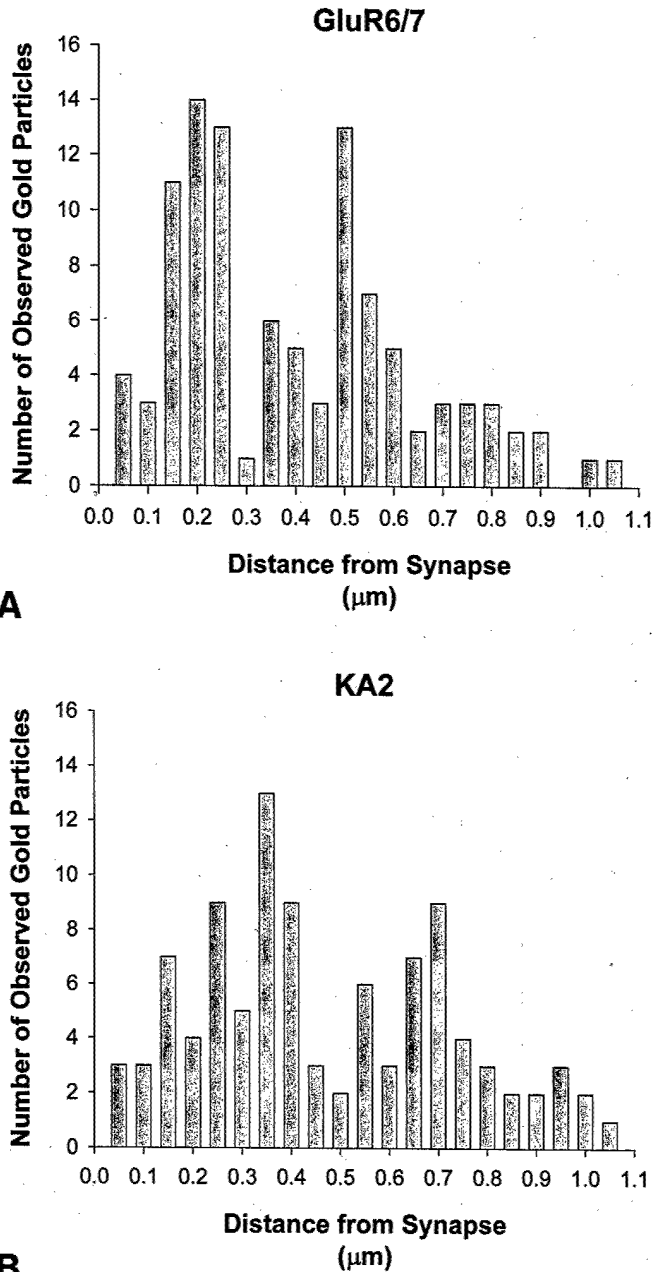

**Figure 7.** Histograms showing the distribution of gold particle labeling for GluR6/7 (*A*) and KA2 (*B*) in relation to the presynaptic grids of asymmetric synapses in the putamen. The mean ( $\pm$ SD) shortest distance of gold particles from the active zones is relatively similar for both KAR subunits antibodies ( $0.40 \pm 0.20 \mu\text{m}$  for GluR6/7;  $0.47 \pm 0.25 \mu\text{m}$  for KA2). Fifteen terminals immunoreactive for GluR6/7 or KA2 were examined.

rents that could be elicited only after high-frequency stimulation of hippocampal mossy fiber pathway in CA3 pyramidal neurons in rats (Castillo et al., 1997; Vignes and Collingridge, 1997; Rodriguez-Moreno and Lerma, 1998). Furthermore, it has been shown that the presynaptic control of GABA release by kainate receptors in the hippocampus is mediated by a metabotropic process that is sensitive to Pertussis toxin and independent of ion channel current (Rodriguez-Moreno and Lerma, 1998). These functional data combined with results of our study clearly indicate that both the localization and functions of kainate receptors are

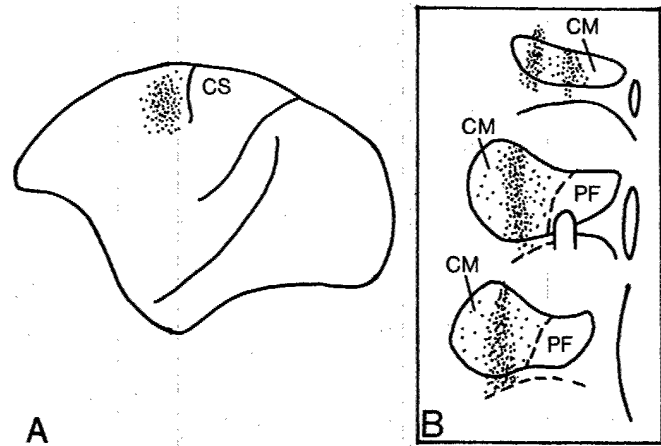

**Figure 8.** BDA injection sites in the primary motor cortex (*A*) and the centromedian nucleus (*B*) in squirrel monkeys. CM, Centromedian nucleus; CS, central sulcus; FR, fasciculus retroflexus; PF, parafascicular nucleus.

**Table 3.** Kainate receptor subunit immunoreactivity in anterogradely labeled thalamic and cortical terminals in the putamen

Sources of terminals	Kainate receptor subunit immunoreactivity	
	GluR6/7 (%)	KA2 (%)
CM	60 ( $N = 55$ )	40 ( $N = 42$ )
M1	28 ( $N = 58$ )	43 ( $N = 51$ )

$N$  = Total number of anterogradely labeled terminals examined.

strikingly different from those of conventional ionotropic glutamate receptors that are largely confined to the main bodies of synaptic active zones (Bernard et al., 1997; Ottersen and Landsend, 1997) and mediate fast synaptic transmission.

It is noteworthy that a substantial level of intracellular AMPA glutamate receptor subunits immunoreactivity has recently been found in dendrites of dorsal cochlear neurons in rats (Rubio and Wenthold, 1999). Interestingly, the receptor subunit labeling was often found in clusters of 2–12 gold particles associated with vesicular structures that strikingly resemble the large organelles immunoreactive for KAR subunits observed in the present study (Rubio and Wenthold, 1999). Although Rubio and Wenthold (1999) showed that some of these structures displayed immunoreactivity for specific markers of endoplasmic reticulum, the majority of labeling was found over elements that were not immunoreactive for ER markers. Future studies are essential to better characterize the exact nature of these glutamate receptor packaging organelles. Presynaptic delta opioid receptors are also expressed on the membrane of large vesicles in primary afferents to the rat spinal cord (Zhang et al., 1998). Whether these vesicles represent an early stage of endosomes and/or a different type of dense-core vesicles remains to be established.

A substantial proportion of presynaptic and postsynaptic gold labeling was also associated with asymmetric synapses, suggesting that kainate receptors may mediate fast excitatory transmission at some glutamatergic synapses in the monkey striatum. However, recent electrophysiological studies could not demonstrate any synaptic activation of kainate receptors after stimulation of striatal glutamatergic afferents (Chergui et al., 2000). At present, there is no clear explanation for this apparent discrepancy between anatomical and functional data. However, these two sets of

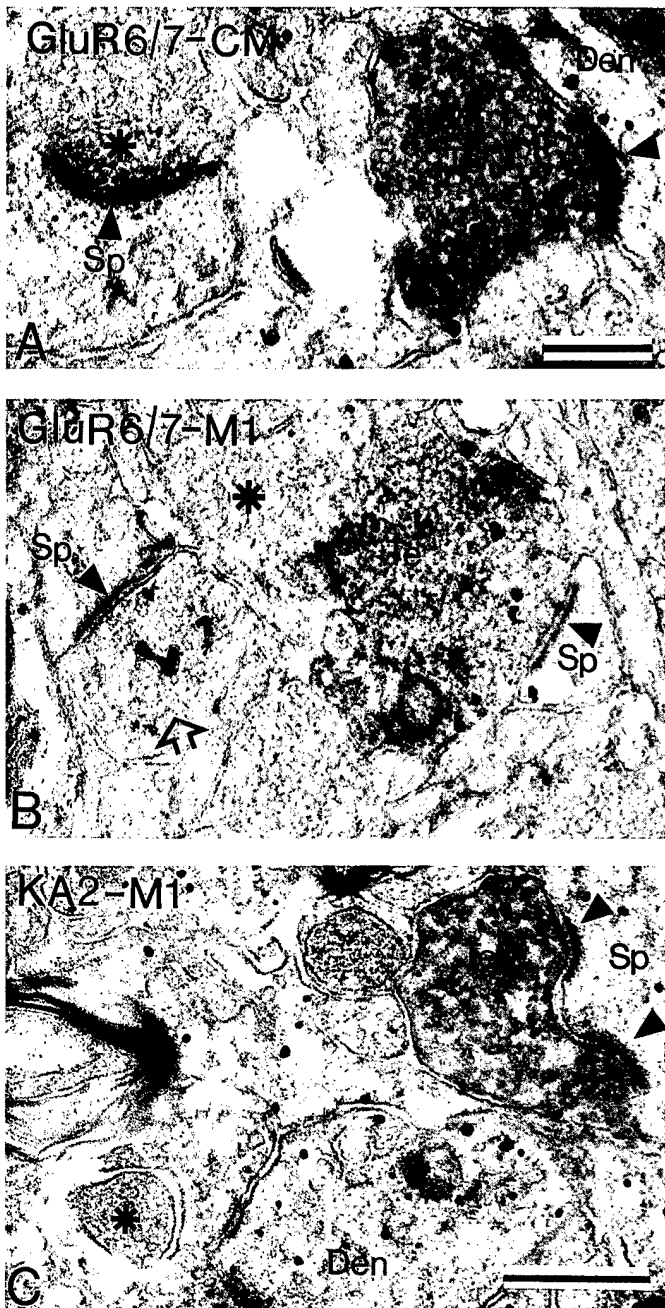

**Figure 9.** GluR6/7-immunoreactive (*A, B*) and KA2-immunoreactive (*C*) terminals (*Te*) labeled anterogradely from the centromedian thalamic nucleus (*CM*) or the primary motor cortex (*M1*) in the putamen. Nonimmunoreactive terminals are indicated by asterisks. Arrowheads point to asymmetric synapses. The open arrow indicates an unlabeled bouton that displays GluR6/7 immunoreactivity. Scale bars: *A*, 0.25  $\mu\text{m}$  (valid for *B*); *C*, 0.5  $\mu\text{m}$ .

findings, combined with those obtained in other brain regions (see below), indicate that the distribution and role of kainate receptors in the CNS are different and likely to be much more complex than those of conventional ionotropic glutamate receptors.

#### Potential functions of presynaptic striatal kainate receptors

The roles of kainate receptors in the striatum are poorly known. However, the toxic effects of kainic acid for striatal projection neurons have long been established although the exact mecha-

nism by which kainic acid induces striatal cell death is still unknown. In this regard, it is noteworthy that the excitotoxic effects of kainic acid for striatal neurons are abolished after decortication (Biziere and Coyle, 1979), which indicates that the glutamatergic corticostriatal projection is somehow involved in mediating this effect. In addition, the fact that striatal cultures become sensitive to kainic acid only when cocultured with cortical neurons is further evidence for the involvement of corticostriatal afferents (Campochiaro and Coyle, 1978; Panula, 1980). In line with these early observations, our data demonstrate that kainate receptors are, indeed, associated presynaptically and postsynaptically with corticostriatal terminals in monkeys. Classically, postsynaptic AMPA and kainate receptors are ligand-gated ion channels permeable to cations, such that activation of these receptors leads to increased  $\text{Na}^+$  and  $\text{Ca}^{2+}$  conductances, and thus neuronal membrane depolarization. If the presynaptic kainate receptors are similar to their postsynaptic counterparts, depolarization of the nerve terminal plasma membrane could conceivably facilitate the opening of  $\text{Ca}^{2+}$  channels linked to glutamate release on arrival of an action potential, and thus potentiate the release of glutamate. Interestingly, recent evidence indicates that activation of GluR6-containing presynaptic kainate receptors facilitates glutamate exocytosis from cerebral cortex nerve terminals in a synaptosome preparation (Perkinton and Sihra, 1999). Similarly, kainate acts at presynaptic receptors to increase GABA release from hypothalamic neurons (Liu et al., 1999). However, kainate was found to downregulate GABAergic transmission in the rat hippocampus (Rodriguez-Moreno et al., 1997). These findings suggest that the effects of presynaptic kainate receptors are strongly dependent on the neuronal type in which they are expressed. It is likely that the mechanisms of action of kainate receptors are also complex and different from one neuronal population to another. For instance, it seems that the presynaptic inhibition of GABA release in the hippocampus is independent of ion channel activity but rather involves the activation of phospholipase C and protein kinase C (PKC) through a Pertussis toxin-sensitive G-protein (Rodriguez-Moreno and Lerma, 1998). One could speculate that the facilitatory effects observed in the cerebral cortex and hypothalamus are mediated via increased calcium conductances in the membrane of the nerve terminals and/or activation of a pool of PKC that facilitates neurotransmitter release. Whether any of these effects are suitable to explain the functions of kainate receptors in the striatum remains to be established.

At first glance, it appears reasonable to believe that presynaptic kainate receptors facilitate glutamate release in the striatum, which might explain why the excitotoxic effects of kainic acid are dependent on the presence of cortical afferents. One could also speculate that the malfunctioning of such receptors in some HD patients might lead to an increased release of glutamate and excitotoxic cell death. However, a recent *in vitro* slice preparation study showed that kainate receptors could not be activated neither by a single or repetitive stimulation of glutamatergic afferents in the rat striatum (Chergui et al., 2000). The authors rather demonstrated that kainate receptors depress GABAergic synaptic transmission indirectly via release of adenosine acting on A2a receptors (Chergui et al. 2000). These data are surprising and difficult to reconcile with our electron microscopic findings showing the abundance of presynaptic kainate receptors in both cortical and thalamic glutamatergic afferents (Charara et al., 1999). However, the physiological conditions under which these kainate receptors are activated remains to be determined. If, under the

experimental conditions used by Chergui et al. (2000), kainate receptors remained in intracellular compartments rather than on the plasma membrane, their lack of responses to stimulation of glutamatergic afferents is not surprising. Future studies are essential to elucidate this issue.

### Concluding remarks

In conclusion, it appears that kainate receptors underlie novel modulatory functions of synaptic transmission. Their extrasynaptic localization combined with metabotropic-like effects shown in the hippocampus suggest that these receptors probably mediate slow modulatory effects rather than fast synaptic transmission. The evidence that the gene encoding the GluR6 subunit might be affected in a subset of HD patients highlights the importance of these receptors in striatal functions in normal and pathological conditions. The use of selective antagonists for kainate and AMPA receptors in normal animals, knock-out mice, and animal model of neurodegenerative diseases will certainly prove useful to clearly assess the role of kainate receptors in the striatum.

### REFERENCES

- Altschul SF, Madden TL, Schaffer AA, Zhang J, Zhang Z, Miller W, Lipman DJ (1997) Gapped BLAST and PSI-BLAST: a new generation of protein database search programs. *Nucleic Acids Res* 25:3389–3402.
- Anwyl R (1999) Metabotropic glutamate receptors: electrophysiological properties and role in plasticity. *Brain Res Rev* 29:83–120.
- Aronin N, Chase K, Young C, Sapp E, Schwarz C, Matta N, Kornreich R, Landwehrmeyer B, Bird E, Beal MF, Vonsattel JP, Smith T, Carraway R, Boyce FM, Young AB, Penney JB, DiFiglia M (1995) CAG expansion affects the expression of mutant huntingtin in the Huntington's disease brain. *Neuron* 15:1193–1201.
- Baude A, Nusser Z, Roberts JD, Mulvihill E, McIlhinney RAJ, Somogyi P (1993) The metabotropic glutamate receptor (mGluR1a) is concentrated at perisynaptic membrane of neuronal subpopulations as detected by immunogold reaction. *Neuron* 11:771–787.
- Bernard V, Somogyi P, Bolam JP (1997) Cellular, subcellular, and sub-synaptic distribution of AMPA-type glutamate receptor subunits in the neostriatum of the rat. *J Neurosci* 17:819–833.
- Bernard V, Levey AI, Bloch B (1999) Regulation of the subcellular distribution of m4 muscarinic acetylcholine receptors in striatal neurons *in vivo* by the cholinergic environment: evidence for regulation of cell surface receptors by endogenous and exogenous stimulation. *J Neurosci* 19:10237–10249.
- Biziere K, Coyle JT (1979) Effects of cortical ablation on the neurotoxicity and receptor binding of kainic acid in striatum. *J Neurosci Res* 4:383–398.
- Blackstad TW, Karagulle T, Ottersen OP (1990) Morforel, a computer program for two-dimensional analysis of micrographs of biological specimens, with emphasis on immunogold preparations. *Comput Biol Med* 20:15–34.
- Campochiaro P, Coyle JT (1978) Ontogenetic development of kainate neurotoxicity: correlates with glutamatergic innervation. *Proc Natl Acad Sci USA* 75:2025–2029.
- Cartmell J, Schoepp DD (2000) Regulation of neurotransmitter release by metabotropic glutamate receptors. *J Neurochem* 75:889–907.
- Castillo PE, Maalenka RC, Nicoll RA (1997) Kainate receptors mediate a slow postsynaptic current in hippocampal CA3 neurons. *Nature* 388:182–186.
- Charara A, Blankstein E, Smith Y (1999) Presynaptic kainate receptors in the monkey striatum. *Neuroscience* 91:1195–1200.
- Chergui K, Bouron A, Normand E, Mulle C (2000) Functional GluR6 kainate receptors in the striatum: indirect downregulation of synaptic transmission. *J Neurosci* 20:2175–2182.
- Chittajallu R, Braithwaite SP, Clarke VRJ, Henley JM (1999) Kainate receptors: subunits, synaptic localization and function. *Trends Pharmacol Sci* 20:26–35.
- Clarke VRJ, Ballyk BA, Hoo KH, Mandelzys A, Pellizzari A, Bath CP, Thomas J, Sharpe EF, Davies CH, Ornstein PL, Schoepp DD, Kamboj RK, Collingridge GL, Lodge D, Bleakman D (1997) A hippocampal GluR5 kainate receptor regulating inhibitory synaptic transmission. *Nature* 389:599–603.
- Conn PJ, Pin J-P (1997) Pharmacology and functions of metabotropic glutamate receptors. *Annu Rev Pharmacol Toxicol* 37:205–237.
- Contractor A, Swanson GT, Sailer A, O'Gorman S, Heinemann SF (2000) Identification of the kainate receptor subunits underlying modulation of excitatory synaptic transmission in the CA3 region of the hippocampus. *J Neurosci* 20:8269–8278.
- Coyle JT, Schwarz R (1976) Lesion of striatal neurones with kainic acid provides a model for Huntington's chorea. *Nature* 263:244–246.
- Debonnel G, Weiss M, de Montigny C (1989) Reduced neuroexcitatory effect of domoic acid following mossy fiber denervation of the rat dorsal hippocampus: further evidence that toxicity of domoic acid involves kainate receptor activation. *Can J Physiol Pharmacol* 67:904–908.
- Frerking M, Nicoll RA (2000) Synaptic kainate receptors. *Curr Opin Neurobiol* 10:342–351.
- Hanson JE, Smith Y (1999) Group I metabotropic glutamate receptors at GABAergic synapses in monkeys. *J Neurosci* 19:6488–6496.
- Hollmann M, Heinemann S (1994) Cloned glutamate receptors. *Annu Rev Neurosci* 17:31–108.
- Hsu SM, Raine L, Fanger H (1981) Use of avidin-biotin-peroxidase complex (ABC) in immunoperoxidase techniques: a comparison between ABC and unlabeled antibody (PAP) procedures. *J Histochem Cytochem* 21:557–580.
- Kamiya H, Ozawa S (2000) Kainate receptor-mediated presynaptic inhibition at the mouse hippocampal mossy fibre synapse. *J Physiol (Lond)* 523:653–665.
- Kieval JZ, Charara A, Paré J-F, Smith Y (2000) Subcellular localization of kainate receptors in the monkey striatum. *Soc Neurosci Abstr* 26:741.15.
- Lerma J, Morales M, Vicenter MA, Herreras O (1997) Glutamate receptors of the kainate type and synaptic transmission. *Trends Neurosci* 20:9–12.
- Liu Q-S, Patrylo PR, Gao X-B, van den Pol AN (1999) Kainate acts at presynaptic receptors to increase GABA release from hypothalamic neurons. *J Neurophysiol* 82:1059–1062.
- Lujan R, Nusser Z, Roberts JDB, Shigemoto R, Somogyi P (1996) Perisynaptic location of metabotropic glutamate receptors mGluR1 and mGluR5 on dendrites and dendritic spines in the rat hippocampus. *Eur J Neurosci* 8:1488–1500.
- MacDonald ME, Vonsattel JP, Shrinidhi J, Couropmitree NN, Cupples LA, Bird ED, Gusella JF, Myers RH (1999) Evidence for the GluR6 gene associated with younger onset age of Huntington's disease. *Neurology* 53:1330–1332.
- Matsubara A, Laake JH, Davanger S, Usami S-I, Ottersen OP (1996) Organization of AMPA receptor subunits at a glutamate synapse: a quantitative immunogold analysis of hair cell synapses in the rat organ of Corti. *J Neurosci* 16:4457–4467.
- McGeer EG, McGeer PL (1976) Duplication of biochemical changes of Huntington's chorea by intrastriatal injections of glutamic and kainic acids. *Nature* 263:517–519.
- McGeer EG, McGeer PL, Singh K (1978) Kainate-induced degeneration of neostriatal neurons: dependency upon corticostriatal tract. *Brain Res* 139:381–383.
- Min M-Y, Melyan Z, Kullmann D (1999) Synaptically released glutamate reduces  $\gamma$ -aminobutyric acid (GABA)ergic inhibition in the hippocampus via kainate receptors. *Proc Natl Acad Sci USA* 96:9932–9937.
- Mulle C, Sailer A, Pérez-Otaño I, Dickinson-Anson H, Castillo PE, Bureau I, Maron C, Gage FH, Mann JR, Bettler B, Heinemann SF (1998) Altered synaptic physiology and reduced susceptibility to kainate-induced seizures in GluR6-deficient mice. *Nature* 392:601–605.
- Nusser Z, Roberts JDB, Baude A, Richards JG, Sieghart W, Somogyi P (1995a) Immunocytochemical localization of  $\alpha 1$  and  $\beta 2/3$  subunits of the GABA-A receptor in relation to specific GABAergic synapses in the dentate gyrus. *Eur J Neurosci* 7:630–646.
- Nusser Z, Roberts JDB, Baude A, Richards JG, Somogyi P (1995b) Relative densities of synaptic and extrasynaptic GABA<sub>A</sub> receptors on cerebellar granule cells as determined by a quantitative immunogold method. *J Neurosci* 15:2948–2960.
- Nyiri G, Freund TF, Somogyi P (2001) Input-dependent synaptic targeting of  $\alpha 2$ -subunit-containing GABA<sub>A</sub> receptors in synapses of hippocampal pyramidal cells of the rat. *Eur J Neurosci* 13:428–442.
- Ottersen OP, Landsend AS (1997) Organization of glutamate receptors at the synapse. *Eur J Neurosci* 9:2219–2224.
- Panula PA (1980) A fine structural and histochemical study on the effect of kainic acid on cultured neostriatal cells. *Brain Res* 181:185–190.
- Pasquini F, Bochet P, Garbay-Jaureguiberry C, Roques BP, Rossier J, Beaudet A (1992) Electron microscopic localization of photoaffinity-labelled delta opioid receptors in the neostriatum of the rat. *J Comp Neurol* 326:229–244.
- Paternain AV, Morales M, Lerma J (1995) Selective antagonism of AMPA receptors unmasks kainate receptor-mediated responses in hippocampal neurons. *Neuron* 14:185–189.
- Penney JB, Vonsattel J-P, MacDonald ME, Gusella JF, Myers RH (1997) CAG repeat number governs development rate of pathology in Huntington's disease. *Ann Neurol* 41:689–692.
- Perkinton MS, Sihra TS (1999) A high-affinity presynaptic kainate-type glutamate receptor facilitates glutamate exocytosis from cerebral cortex nerve terminals (synaptosomes). *Neuroscience* 90:1281–1292.
- Persichetti F, Srinidhi J, Kanaley L, Ge P, Myers RH, D'Arrigo K, Barnes

- GT, MacDonald ME, Vonsattel JP, Gusella JF (1994) Huntington's disease CAG trinucleotide repeats in pathologically confirmed post-mortem brains. *Neurobiol Dis* 1:159–166.
- Petralia RS, Wang Y-X, Wenthold RJ (1994) Histological and ultrastructural localization of the kainate receptor subunits, KA2 and GluR6/7, in the rat nervous system using selective antipeptide antibodies. *J Comp Neurol* 349:85–110.
- Reynolds ES (1963) The use of lead citrate at high pH as an electron opaque stain in electron microscopy. *J Cell Biol* 17:208–212.
- Rodriguez-Moreno A, Lerma J (1998) Kainate receptor modulation of GABA release involves a metabotropic function. *Neuron* 20:1211–1218.
- Rodriguez-Moreno A, Herreras O, Lerma J (1997) Kainate receptors presynaptically downregulate GABAergic inhibition in the rat hippocampus. *Neuron* 19:893–901.
- Rubinsztein DC, Leggo J, Chiano M, Dodge A, Norbury G, Rosser E, Craufurd D (1997) Genotypes at the GluR6 kainate receptor locus are associated with variation in the age of onset of Huntington disease. *Proc Natl Acad Sci USA* 94:3872–3876.
- Rubio ME, Wenthold RJ (1999) Differential distribution of intracellular glutamate receptors in dendrites. *J Neurosci* 19:5549–5562.
- Sadikot AF, Parent A, Smith Y, Bolam JP (1992) Efferent connections of the centromedian and parafascicular thalamic nuclei in the squirrel monkey: a light and electron microscopic study of the thalamostriatal projection in relation to striatal heterogeneity. *J Comp Neurol* 320:228–242.
- Shink E, Bevan MD, Bolam JP, Smith Y (1996) The subthalamic nucleus and the external pallidum: two tightly interconnected structures that control the output of the basal ganglia in the monkey. *Neuroscience* 73:335–357.
- Sidibé M, Smith Y (1996) Differential synaptic innervation of striatofugal neurones projecting to the internal or external segments of the globus pallidus by thalamic afferents in the squirrel monkey. *J Comp Neurol* 365:445–465.
- Sidibé M, Bevan MD, Bolam JP, Smith Y (1997) Efferent connections of the internal globus pallidus in the squirrel monkey: I. Topography and synaptic organization of the pallidothalamic projection. *J Comp Neurol* 382:323–347.
- Smith Y, Bennett BD, Bolam JP, Parent A, Sadikot AF (1994) Synaptic relationships between dopaminergic afferents and cortical or thalamic input in the sensorimotor territory of the striatum in monkeys. *J Comp Neurol* 344:1–19.
- Smith Y, Charara A, Hanson JE, Paquet M, Levey AI (2000) GABA<sub>B</sub> and group I metabotropic glutamate receptors in the striatopallidal complex in primates. *J Anat* 196:555–576.
- Smith Y, Charara A, Paquet M, Kieval JZ, Paré J-F, Hanson JE, Hubert GW, Kuwajima M, Levey AI (2001) Ionotropic and metabotropic GABA and glutamate receptors in primate basal ganglia. *J Chem Neuroanat* 22:13–42.
- Valtschanoff JG, Weinberg RJ (2001) Laminar organization of the NMDA receptor complex within the postsynaptic density. *J Neurosci* 21:1211–1217.
- Vignes M, Collingridge GL (1997) The synaptic activation of kainate receptors. *Nature* 388:179–182.
- Vonsattel JPG, DiFiglia M (1998) Huntington disease. *J Neuropathol Exp Neurol* 57:369–384.
- Wang H, Moriwaki A, Wang JB, Uhl GR, Pickel VM (1997) Ultrastructural immunocytochemical localization of  $\mu$ -opioid receptors in dendritic targets of dopaminergic terminals in the rat caudate-putamen nucleus. *Neuroscience* 81:757–771.
- Wenthold RJ, Trump VA, Zhu WS, Petralia RS (1994) Biochemical and assembly properties of GluR6 and KA2, two members of the kainate receptor family, determined with subunit-specific antibodies. *J Biol Chem* 269:1332–1339.
- Zhang X, Bao L, Arvidsson U, Elde R, Hökfelt T (1998) Localization and regulation of the delta-opioid receptor in dorsal root ganglia and spinal cord of the rat and monkey: evidence for association with the membrane of large dense-core vesicles. *Neuroscience* 82:1225–1242.



## Ionotropic and metabotropic GABA and glutamate receptors in primate basal ganglia

Yoland Smith <sup>a,b,\*</sup>, Ali Charara <sup>a</sup>, Maryse Paquet <sup>a</sup>, Jeremy Z. Kieval <sup>a</sup>,  
Jean-François Paré <sup>a</sup>, Jesse E. Hanson <sup>a</sup>, George W. Hubert <sup>a</sup>, Masaaki Kuwajima <sup>a</sup>,  
Allan I. Levey <sup>b</sup>

<sup>a</sup> Division of Neuroscience, Yerkes Regional Primate Research Center, Emory University, 954, Gatewood Rd NE, Atlanta, GA 30322, USA

<sup>b</sup> Department of Neurology, Emory University, Woodruff Memorial Building, Suite 6000, PO Drawer V, Atlanta, GA 30322, USA

Received 31 July 2000; received in revised form 13 November 2000; accepted 13 November 2000

### Abstract

The functions of glutamate and GABA in the CNS are mediated by ionotropic and metabotropic, G protein-coupled, receptors. Both receptor families are widely expressed in basal ganglia structures in primates and nonprimates. The recent development of highly specific antibodies and/or cDNA probes allowed the better characterization of the cellular localization of various GABA and glutamate receptor subtypes in the primate basal ganglia. Furthermore, the use of high resolution immunogold techniques at the electron microscopic level led to major breakthroughs in our understanding of the subsynaptic and subcellular localization of these receptors in primates. In this review, we will provide a detailed account of the current knowledge of the localization of these receptors in the basal ganglia of humans and monkeys. © 2001 Elsevier Science B.V. All rights reserved.

### 1. Introduction

Although the implication of “the basal ganglia” in the control of motor behaviors has long been known, the exact mechanisms by which these brain regions participate in motor control is still obscure and controversial. Furthermore, it is now clear that the functions of basal ganglia extend far beyond mere sensorimotor integration to include major cognitive and limbic components. The evidence that many neurodegenerative diseases of the basal ganglia often lead to major cognitive impairment accompanied by psychiatric problems strongly support the non-motor functions of these brain regions (Brown and Marsden, 1984; Marsden, 1984; Brown and Marsden, 1988; Sano et al., 1989; Mayeux et al., 1990, 1992). Our knowledge of the anatomy and pathophysiology of primate basal ganglia has increased dramatically over the past 20 yr due to the introduction of highly sensitive chemoanatomical methods, brain imaging techniques and the discovery of 1-methyl-4-

phenyl-1,2,3,6-tetrahydropyridine (MPTP), a chemical which selectively kills midbrain dopaminergic neurons in primates and induces Parkinson's disease (PD) (Davis et al., 1979; Langston et al., 1983). The MPTP model of PD is one of the best animal model of neurodegenerative diseases currently available. The use of this animal model has led to major breakthroughs in our understanding of the functional circuitry of the basal ganglia and served as the cornerstone for the development of novel surgical and pharmacological therapies for PD (see Starr, 1995; Blandini et al., 1996; Poewe and Granata, 1997; Vitek, 1997 for reviews).

The work that has been carried out in our laboratory over the past 10 yr has aimed at understanding various aspects of the connectivity and synaptic organization of the basal ganglia in non-human primates (Smith et al., 1998a,b). The recent development of highly sophisticated electron microscopic immunocytochemical approaches allowed us and others to better characterize the subsynaptic and subcellular localization of neurotransmitter receptors involved in mediating synaptic communication at various GABAergic and glutamatergic synapses in the primate basal ganglia (Paquet and Smith, 1996; Paquet et al., 1997; Waldvogel et al., 1998;

\* Corresponding author. Tel.: +1-404-7277519; fax: +1-404-7273278.

E-mail address: yolands@rmy.emory.edu (Y. Smith).

Charara et al., 1999; Hanson and Smith, 1999; Waldvogel et al., 1999; Charara et al., 2000a; Smith et al., 2000a). Unfortunately, due to problems inherent to postmortem tissue with the preservation of ultrastructural features, such studies cannot be carried out in human material. However, due to similarities in the subcortical organization of basal ganglia structures in human and non-human primates, there is a high likelihood that our findings in monkeys can be extrapolated to humans. In this review, we will present some of our most recent data on the subsynaptic localization of metabotropic glutamate receptors and GABA-B receptors in the monkey basal ganglia. We will also give a brief overview of the current knowledge of the localization of various subtypes of glutamate and GABA receptors in the human basal ganglia largely based on data gathered by autoradiographic binding studies, in situ hybridization method, light microscopic immunocytochemical method and PET imaging technique. Finally, we will examine the possibility of using novel drug therapies directed towards specific subtypes of G protein-coupled glutamate and GABA receptors to treat PD.

Because of the scope of the paper, this review will mostly cover data gathered in monkeys and humans. The reader is referred to recent extensive reviews and compendia related to basal ganglia research for a more extensive coverage of literature (Joel and Weiner, 1994; Percheron et al., 1994; Parent and Hazrati, 1995; Chesselet and Delfs, 1996; Gerfen and Wilson, 1996; Ohye et al., 1996; Joel and Weiner, 1997; Levy et al., 1997; Smith et al., 1998a,b; Wilson, 1998).

## 2. Basal ganglia circuitry

### 2.1. Striatal afferents

In primates, the basal ganglia are comprised of five tightly interconnected subcortical structures involved in the integration and processing of sensorimotor, cognitive and limbic information. The main entrance of cortical information to the basal ganglia circuitry is the striatum which is comprised of the caudate nucleus (CD), putamen (PUT) and nucleus accumbens (Acc). The glutamatergic corticostriatal projection is highly topographic and imposes a functional compartmentation of striatal regions. The post-commissural PUT receives inputs from the primary motor and somatosensory cortices as well as PM and SMAs whereas the pre-commissural PUT and the CD are the main targets of associative cortical regions. On the other hand, the bulk of cortical afferents to the Acc arise from limbic cortices, amygdala and hippocampus (Heimer et al., 1995). Another level of striatal compartmentation is the patch/matrix organization. This concept, which origi-

nally relied upon the heterogeneous distribution of acetylcholinesterase is now considered to be a basic framework of striatal architecture. Most neurotransmitters and neuropeptides as well as major striatal afferent projections and striatal output neurons display a preferential distribution for the patch or the matrix compartment (Graybiel, 1990).

Another major glutamatergic input to the striatum arises from the caudal intralaminar thalamic nuclei, namely the centromedian (CM) and parafascicular (Pf) nuclear complex (Smith and Parent, 1986; Sadikot et al., 1992a,b; Parent and Hazrati, 1995). Projections from the CM terminate preferentially in the sensorimotor striatal territory whereas inputs from Pf innervate the associative and limbic striatal regions (Sadikot et al., 1992b). Finally, the substantia nigra pars compacta (SNc) and the ventral tegmental area (VTA) are the two main sources of dopamine to the dorsal and ventral striatum, respectively. Additional sources of innervation of the striatum include the external globus pallidus (GPe), the subthalamic nucleus (STN), the dorsal raphe and the tegmental pedunculopontine nucleus (TPP) (Smith and Parent, 1986) (Fig. 1).

The main targets of striatal afferents are the GABAergic medium sized spiny projection neurons which account for more than 90% of the total neuronal population of the striatum (Smith and Bolam, 1990). The glutamatergic inputs from the cortex terminate almost exclusively on the heads of dendritic spines whereas the thalamic afferents from CM/Pf preferentially innervate dendritic trunks (Sadikot et al., 1992a; Smith et al., 1994). Dopamine and cortical inputs often converge at the level of individual spines, which supports the tight functional interaction between dopamine and glutamate in mediating proper basal ganglia functions (Smith et al., 1994). In addition to projection neurons, the striatum is also endowed with various populations of aspiny interneurons recognized by their size and differential content in neurotransmitter, neuropeptides and calcium binding proteins. Four main classes of interneurons have been recognized in the primate striatum: (1) the cholinergic neurons, (2) the parvalbumin-containing neurons, which co-express GABA, (3) the somatostatin-containing neurons which also contain neuropeptide Y and nitric oxide synthase and (4) the calretinin-containing neurons. Albeit less massively innervated than spiny neurons, interneurons also receive direct cortical, thalamic and nigral inputs (Kawaguchi et al., 1995; Sidibé and Smith, 1999; Bolam et al., 2000).

### 2.2. Direct and indirect striatofugal pathways

Once integrated and processed at the striatal level, the information is conveyed to the basal ganglia output structures, the internal globus pallidus (GPi) and the

substantia nigra pars reticulata (SNr), via two pathways: (1) The direct pathway, which arises from a subset of striatal projection neurons enriched in substance P/dynorphin and D1 dopamine receptors, terminates directly in GPi and SNr or (2) the indirect pathways, which originate from striatal neurons enriched in enkephalin and D2 dopamine receptors, terminate in GPe (Albin et al., 1989; Bergman et al., 1990; Gerfen et al., 1990). In turn, GPe neurons provide GABAergic inputs to the STN, which relays signals to the basal ganglia output nuclei. Imbalance in the activ-

ity of these two pathways, in favor of the indirect pathway, underlies some of the motor deficits in PD (DeLong, 1990; Wichmann and DeLong, 1996). The model of direct and indirect pathways as originally introduced was, by necessity, a simplification and only included the major projections of sub-nuclei of the basal ganglia (Albin et al., 1989; Bergman et al., 1990). However, since its introduction there have been many developments in our knowledge and understanding of the anatomical and synaptic organisation of the basal ganglia that have led to reconsideration and updates of

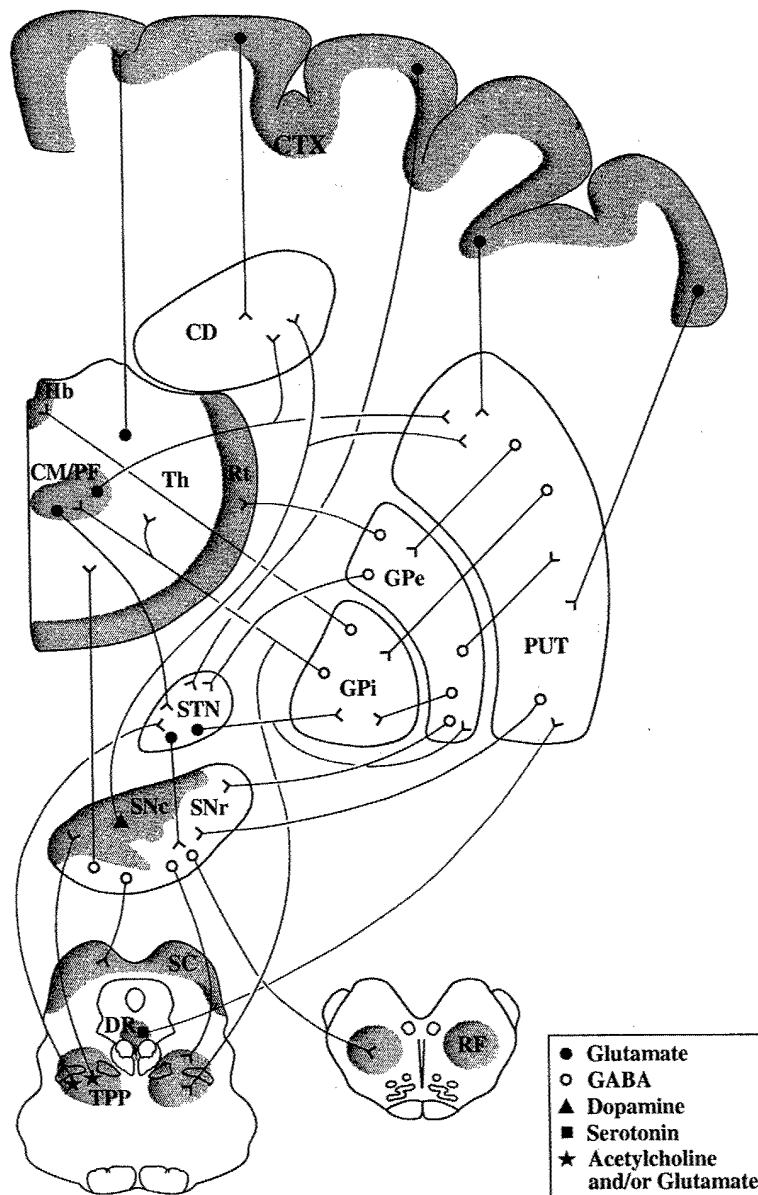

Fig. 1. Connectivity of the primate basal ganglia: schematic representation of the main afferent and efferent connections of basal ganglia structures in primates. For the sake of clarity, some connections have been omitted. Abbreviations: CD: caudate nucleus; CM/Pf: Center median/parafascicular complex; CTX: cerebral cortex; DR: dorsal raphe; GPe: globus pallidus, external segment; GPi: globus pallidus, internal segment; Hb: habenular nucleus; PUT: putamen; RF: reticular formation; Rt: reticular nucleus; SC: superior colliculus; SNc: substantia nigra pars compacta; SNr: substantia nigra pars reticulata; STN: subthalamic nucleus; Th: thalamus, TPP: tegmental pedunculopontine nucleus.

some aspects of the model. One of the most important new finding regarding the anatomical organization of the basal ganglia is the demonstration of multiple indirect pathways of information flow through the basal ganglia. In addition to the classical indirect pathway through the GPe and the STN, it is now well established that the GPe gives rise to GABAergic projections that terminate in basal ganglia output structures (GPi, SNr), the reticular nucleus of the thalamus and the striatum (see Parent and Hazrati, 1995; Smith et al., 1998a,b for reviews) (Fig. 1). Even if the exact functions of these connections remain unknown, it should be kept in mind that the circuitry of the basal ganglia as outlined in the original model of “direct and indirect” pathways is likely to be more complex than previously thought (Smith et al., 1998a). It is noteworthy that molecular and anatomical data showing: (1) a higher degree of co-localization of D1 and D2 dopamine receptors in striatal projection neurons and (2) a higher degree of collateralization of individual “direct” striatofugal neurons recently challenged the concept of direct and indirect pathways (see Gerfen and Wilson, 1996 for a review). Although these findings do not rule out the segregation of striatofugal neurons, they must be kept in mind while considering the functional significance of the direct and indirect striatofugal pathways in normal and pathological conditions.

### 2.3. Basal ganglia outflow

Once the information has reached the GPi and SNr, it is conveyed to various thalamic and brainstem nuclei which project to motor and pre-motor (PM) cortical areas or to lower brainstem regions. Although both the GPi and SNr project to the ventral anterior/ventral lateral thalamic complex (VA/VL), the nigral and pallidal afferents largely terminate in different subdivisions of the VA/VL nuclei in primates (Ilinsky et al., 1993). Other targets of SNr neurons include the brainstem TPP, the superior colliculus and the medullary reticular formation (Fig. 1). The nigrocollicular fibers, which terminate mainly onto tectospinal neurones in the intermediate layer of the superior colliculus, play a critical role in the control of visual saccades. At thalamic level, inputs from the medial part of the SNr terminate mostly in the medial magnocellular division of the VA (VAmc) and the mediodorsal nucleus (MDmc) which, in turn, innervate anterior regions of the frontal lobe including the principal sulcus (Walker’s area 46) and the orbital cortex (Walker’s area 11) in monkeys (Ilinsky et al., 1985). On the other hand, neurones in the lateral part of the SNr project preferentially to the lateral posterior region of the VAmc and to different parts of the MD mostly related to posterior regions of the frontal lobe including the frontal eye field and areas of the premotor cortex (see Sidibé et al., 1997 for a

review). Another thalamic target of SNr neurons is the caudal intralaminar Pf, which provides a massive feedback projection to the CD (Ilinsky et al., 1985; Smith et al., 2000b).

In addition to the VA/VL and caudal intralaminar thalamic nuclei, the lateral habenular nucleus and the TPP also receive significant inputs from GPi. Efferents from the sensorimotor GPi remain largely segregated from the associative and limbic projections at the level of the thalamus whereas they partly overlap in the TPP (Shink et al., 1997; Sidibé et al., 1997). On the other hand, limbic and associative pallidal projections innervate common nuclei in the thalamus and TPP. In squirrel monkeys, the sensorimotor GPi outputs are directed towards the posterior VL (VLp), whereas the associative and limbic GPi preferentially innervate the parvocellular ventral anterior (VApc) and the dorsal VL (VLd). The ventromedial nucleus receives inputs from the limbic GPi only (Sidibé et al., 1997). These findings, therefore, suggest that some associative and limbic cortical information, which is largely processed in segregated corticostriatopallidal channels, converge at common thalamic nuclei in monkeys (Sidibé et al., 1997). The basal ganglia influences are then conveyed to the cerebral cortex via the VA/VL nuclei. Although it has long been thought that the sensorimotor information from the GPi was conveyed exclusively to the supplementary motor area (SMA), recent anatomical and physiological data in macaques demonstrate that the information from the GPi may also be sent to the primary motor cortex (M1) and the PM cortical area (Rouillier et al., 1994; Hoover and Strick, 1999). Retrograde transneuronal virus studies showed that different populations of GPi neurones project to SMA, M1 and PM (Middleton and Strick, 2000).

Most pallidal neurons which project to thalamic relay nuclei send axon collaterals to the caudal intralaminar nuclei where they are distributed according to a specific pattern of functional organization. Pallidal axons arising from the sensorimotor GPi terminate exclusively in CM, where they form synapses with thalamostriatal neurons projecting back to the sensorimotor territory of the striatum (Smith and Sidibé, 1999). In contrast, associative inputs from the caudate-receiving territory of GPi terminate massively in a dorsolateral extension of Pf (PFdl) which, surprisingly, does not project back to the CD but rather preferentially innervates the pre-commissural region of the PUT. Finally, the limbic GPi selectively innervates the rostradorsal part of Pf which gives rise to the thalamo-accumbens projection (Sidibé et al., 1997; Smith et al., 1998b; Smith and Sidibé, 1999). Therefore, it appears that the CM/Pf is part of closed and open functional loops with the striatopallidal complex (Smith and Sidibé, 1999). Neurons in Pf that project to the CD do not receive inputs from any functional regions of GPi,

but receive substantial innervation from the SNr (Smith et al., 2000b).

In monkeys, more than 80% of GPi neurones that project to the VA/VL send axon collaterals to the TPP (Parent and Hazrati, 1995). In contrast to the thalamus that conveys the basal ganglia information to the cerebral cortex, the TPP gives rise to descending projections to the pons, medulla and spinal cord as well as prominent ascending projections to the different structures of the basal ganglia, the thalamus and the basal forebrain (Inglis and Winn, 1995; Rye, 1997). The pallidotegmental projection may thus be a route by which information can escape from the basal ganglia-thalamocortical circuitry and reach lower motor and autonomic centers.

### 3. Glutamate and GABA receptor families in the CNS

Glutamate and GABA receptors are categorized in two main groups based on their structure and mechanisms of actions. The ionotropic receptors are ligand-gated ion channels, which mediate fast synaptic transmission whereas the metabotropic receptors are coupled to G proteins and initiate intracellular signaling cascades.

#### 3.1. Ionotropic and metabotropic glutamate receptors

Two main subtypes of ionotropic glutamate receptors have been identified: the *N*-methyl-D-aspartate (NMDA) receptors and the alpha-amino-3-hydroxy-5-methyl-4-isoxazole (AMPA)/kainate receptors. Numerous subunits and variants constituting the different types of ionotropic glutamate receptors have now been cloned and sequenced. Various factors, including the subunit composition and the relative abundance of these subunits influence the biophysical properties of these receptors. The NMDA receptors consist of eight splice variants (named a–h) of the NMDAR1 subunit and four different NMDAR2 receptor subunits (NR2A, NR2B, NR2C and NR2D), whereas the AMPA receptors are made up of the GluR1–4 subunits. Finally, heteromeric combinations of the high-affinity kainate binding subunits (GluR5–7; KA1–2) form the kainate receptors (Gasic and Hollmann, 1992; Hollmann and Heinemann, 1994; Westbrook, 1994). In general, activation of AMPA and kainate receptors is responsible for primary events in fast glutamatergic transmission since NMDA receptors only become fully activated by glutamate secondarily when their  $Mg^{+2}$  block is relieved by depolarization.

The metabotropic glutamate receptor family includes eight different subtypes pooled into three major groups based on their sequence homology, pharmacological properties and transduction mechanisms. In vitro data have shown that the group I mGluRs, which include

the splice variants of mGluR1 (a,b,c,d) and mGluR5 (a,b), are positively coupled via Gq to phospholipase C and PI hydrolysis. Activation of these receptors, which are usually found postsynaptically, generally leads to slow depolarization, though presynaptic group I mGluRs were also found in some brain regions (Nakanishi, 1994; Pin and Duvoisin, 1995; Conn and Pin, 1997). Group II mGluRs (mGluR2,3) are negatively coupled via Gi/Go to adenylyl cyclase and inhibit the formation of cyclic AMP following exposure to forskolin or activation of an intrinsic Gs-coupled receptor. Similarly, group III mGluRs (mGluR4,6,7,8) inhibit adenylyl cyclase via a pertussis toxin sensitive G-protein. Group II and group III mGluRs are generally found presynaptically where they act as auto- or hetero-receptors to modulate the release of glutamate or other neurotransmitters (see Cartmell and Schoepp, 2000 for a review). The three groups of mGluRs can be further differentiated pharmacologically by their selective sensitivity to specific agonists (Nakanishi, 1994; Conn and Pin, 1997; Schoepp et al., 1999). However, selective compounds for specific subtypes of receptors in the same group are still missing, except for the recent development of specific antagonists for mGluR1 and mGluR5 (see Schoepp et al., 1999 for a review).

#### 3.2. Three major groups of GABA receptors

The GABA receptors are pooled into three groups. The GABA-A receptors, which are ligand-gated chloride channels, mediate fast inhibitory transmission in the CNS. These receptors are pentameric glycoproteins made up of various subunits which, to date, can be categorized into seven groups based on sequence homology ( $6\alpha$ ,  $4\beta$ ,  $4\gamma$ ,  $1\delta$ ,  $1\epsilon$ ,  $1\pi$ ,  $1\theta$ ) (Macdonald and Olsen, 1994; Bonnert et al., 1999; Mehta and Ticku, 1999). The combinational assembly of these subunits (and splice variants of several of them) into a pentameric structure results in diverse receptor subtypes. In vivo, fully functional GABA-A receptors are generally made up of a combination of  $\alpha$ ,  $\beta$  and  $\gamma 2$  subunits. About 80% of all GABA-A receptors in the CNS are sensitive to benzodiazepines (BZ) and contain the classical BZ binding sites (Möhler et al., 1997; Upton and Blackburn, 1997; Mehta and Ticku, 1999). The  $\gamma 2$  subunit is essential to convey BZ sensitivity to GABA-A receptors which is consistent with the widespread distribution of this subunit in the brain. This BZ sensitivity has been instrumental for the development of various ligands to map the distribution of GABA-A receptor binding sites in the human CNS (see below). Another particular feature of GABA-A receptors is their sensitivity for the highly specific agonist and antagonist, muscimol and bicuculline.

Another major subtype of GABA receptors in the CNS is the GABA-B receptors, which were identified in

the early 1980s as a novel type of bicuculline-insensitive  $\text{Cl}^-$ -independent GABA receptors (Hill and Bowery, 1981). GABA-B receptors, which are selectively activated by baclofen and insensitive to bicuculline (Bowery et al., 1980; Hill and Bowery, 1981), belong to the family of seven transmembrane domain receptors and are coupled to  $\text{Ca}^{2+}$  and  $\text{K}^+$  channels via G proteins and second messenger systems, e.g. inhibiting adenylate cyclase (Bormann, 1997; Bowery, 1997; Deisz, 1997). GABA-B receptors generate the late inhibitory postsynaptic potentials that are important for the fine tuning of inhibitory neurotransmission (Bettler et al., 1998). During the past few years, an impressive amount of work has been devoted to the mechanisms of GABA-B action in the CNS (see reviews by Kerr and Ong, 1995; Misgeld et al., 1995; Bowery, 1997; Deisz, 1997). The development of potent GABA-B antagonists (Olpe et al., 1990; Bittiger et al., 1993; Froestl et al., 1999; Ong et al., 1999) has greatly facilitated the investigation of the various facets of GABA-B receptors. Recent cloning of GABA-B receptor subtypes revealed extended similarity with metabotropic glutamate receptors. So far, two GABA-B receptor subunits have been identified, GABA-BR1 and GABA-BR2 which assemble into heterodimers to form a functional GABA-B receptor (Bettler et al., 1998; Jones et al., 1998; Kaupmann et al., 1998; White et al., 1998; Kuner et al., 1999; Makoff, 1999; Martin et al., 1999).

Finally, the last group of GABA receptors are the GABA-C receptors which, like GABA-A receptors, are members of the ligand-gated ion-channel superfamily receptors permeable to chloride ions. However, GABA-C receptors stand as a separate class of receptors due to their lack of sensitivity to bicuculline and baclofen (Johnston, 1997). Another feature that characterizes GABA-C receptors is their lack of sensitivity to BZ and barbiturates. Furthermore, these receptors are activated at lower concentrations of GABA and are less liable to desensitization than most GABA-A receptors. GABA-C receptors are made up of  $\rho$  subunits which were cloned in the early 1990s from a human retinal library. To date, three  $\rho$  subunit cDNAs have been characterized, but very little is known about their functions and distribution in the primate brain (Johnston, 1997). Although originally thought to be expressed exclusively in the retina, recent *in situ* hybridization studies revealed a much broader distribution of these receptor subunits in the rodent and human brain (Enz et al., 1995; Wegelius et al., 1998; Enz and Cutting, 1999).

#### 4. Technical developments for the localization of neurotransmitter receptors

The cloning techniques combined with the development of sensitive high resolution electron microscopic

immunocytochemical methods led to major breakthroughs in our current knowledge of receptor localization in the CNS. Although autoradiographic ligand binding method has long been a major tool used to visualize receptor binding sites in the brain, the lack of resolution of this approach significantly hampers the interpretation of the exact neuronal localization of receptor subtypes. A better resolution can be obtained using the techniques of light and electron microscopic immunocytochemistry and *in situ* hybridization. However, due to limitations inherent to postmortem tissue in the preservation of membranes and glycoprotein antigenicity, the immunocytochemical detection of receptors at the electron microscopic level in human brain is limited, which makes the ligand binding methods still the most commonly used tool to study receptor distribution in postmortem human brain tissue (see below).

The electron microscopic immunogold methods provide a way by which the exact localization and relative abundance of receptors in relation to specific release sites of neurotransmitters can be studied (Van Lookeren Campagne et al., 1991; Nusser et al., 1994; Matsubara et al., 1996). In our laboratory, we use two different immunogold methods to study glutamate and GABA receptors in the monkey basal ganglia, namely the pre-embedding silver-intensified immunogold method and the freeze-substitution post-embedding immunogold technique. These approaches combined with the regular immunoperoxidase method provide complementary information which help characterize the precise localization of a particular receptor in the brain. The main advantage of the immunogold methods over the immunoperoxidase technique is the higher level of spatial resolution of gold particles in comparison to the amorphous diaminobenzidine (DAB) reaction product. However, the immunoperoxidase approach still remains the most sensitive technique to detect low level of receptor proteins. In the pre-embedding immunogold method, a secondary antibody conjugated to 1.4 nm gold particles, rather than the peroxidase complexes, is used to localize the antigenic sites. The size of the gold particles is, then, increased by silver intensification which results in 30–50 nm electron-dense particles. The main problem with this approach is the poor penetration of gold-conjugated antibodies which limits the electron microscopic analysis to the most superficial part of tissue sections and significantly hampers the interpretation of negative data. For that reason, the post-embedding immunogold technique is definitely the only reliable approach to quantify and unequivocally compare receptor densities associated with different synapses on the same section. In order to maintain the antigenicity of GABA and glutamate receptors after embedding, it is necessary to use the technique of fast freezing followed by low temperature dehydration (a process named freeze-substitution) and low temperature

embedding of fixed brain tissue in non-polar resin (Baude et al., 1993; Nusser et al., 1994; Baude et al., 1995; Nusser et al., 1995; Lujan et al., 1996; Matsubara et al., 1996; Bernard et al., 1997; Nusser et al., 1997; Ottersen and Landsend 1997; Bernard and Bolam, 1998; Clarke and Bolam, 1998; Nusser et al., 1998; Nusser, 1999).

## 5. Glutamate and GABA receptors in the striatum

### 5.1. Ionotropic glutamate receptors

#### 5.1.1. AMPA receptors

The localization of AMPA receptors in the human striatum has been studied in normal and pathological conditions by means of autoradiographic ligand binding (Dure et al., 1991, 1992; Lee and Choi, 1992; Ball et al., 1994; Noga et al., 1997; Healy et al., 1998; Blue et al., 1999), in situ hybridization (Bernard et al., 1996; Tomiyama et al., 1997; Healy et al., 1998) and light microscopic immunohistochemistry (Meng et al., 1997; Cicchetti et al., 1999). Overall, the whole human striatum is quite enriched in AMPA receptor binding sites but a slightly higher density is found in the matrix compartment (Dure et al., 1992). Analysis of striatal AMPA binding sites in various pathological conditions revealed: (1) either no significant differences (Healy et al., 1998) or increases (Noga et al., 1997) in AMPA binding sites in schizophrenics, (2) significant reductions in AMPA receptor bindings in the PUT of girls with Rett syndrome (Blue et al., 1999) and (3) significant decreases of AMPA binding sites in the CD of Huntington's patients (Dure et al., 1991). More recent studies using in situ hybridization and immunohistochemical methods revealed that the GluR1,2,3 subunits are widely expressed in both projection neurons and large interneurons in the human striatum whereas GluR4 is confined to a small population of large- and medium-sized neurons (Bernard et al., 1996; Meng et al., 1997; Tomiyama et al., 1997). Subpopulations of large and medium CR-containing interneurons are endowed with GluR1, GluR2 and GluR4 AMPA receptor subunits (Cicchetti et al., 1999). It is noteworthy that GluR4 mRNA and immunoreactivity is confined to interneurons in the rat striatum (Tallaksen-Greene and Albin, 1994; Chen et al., 1996; Bernard et al., 1997). No significant changes in GluR1–4 mRNA expression was found in the striatum of parkinsonian patients (Bernard et al., 1996).

In monkeys, GluR1,2,4 immunoreactivities are found in medium-sized projection neurons in both the CD and PUT (Martin et al., 1993). In contrast, large cholinergic interneurons, which partly co-localize with CR in humans (Cicchetti et al., 1998), express GluR4 immunoreactivity but are devoid of GluR1 and GluR2/3 labeling

(Martin et al., 1993). GluR1, but not GluR2/3 or GluR4 immunoreactivity, is more intense in the ventral striatum than the dorsal striatum. In the CD, GluR1 is preferentially expressed in medium sized spiny neurons in patches whereas the matrix contains large GluR4-containing cholinergic interneurons (Martin et al., 1993). Recent data showed an upregulation of the AMPA GluR1 subunit in the striatal patch compartment of MPTP-treated parkinsonian monkeys (Betarbet et al., 2000). Most intrinsic dopaminergic neurons in the monkey striatum, which increase substantially in number after MPTP treatment, express GluR1, but not GluR2/3 immunoreactivity (Betarbet and Greenamyre, 1999).

At the electron microscopic level, the GluR1 subunit is enriched in dendritic spines (Martin et al., 1993), which is consistent with recent immunogold data showing that the bulk of AMPA receptor subunit immunoreactivity is confined to asymmetric axo-spinous synapses in the rat striatum (Bernard et al., 1997).

#### 5.1.2. Kainate receptors

Due to the lack of specific markers that could differentiate kainate from AMPA receptor binding sites, very little is known about the localization of kainate receptors in the human striatum. Using in situ hybridization approach, Bernard et al. (1996) showed that the GluR6, GluR7 and KA2 receptor subunits are detected in about 50–60% of striatal medium-sized neurons whereas the KA1 labeling is restricted to 20–30% of these neurons. Less than 2% of striatal neurons express the GluR5 subunit mRNA (Bernard et al., 1996).

We recently carried out a detailed analysis of the subsynaptic localization of kainate receptor subunit immunoreactivity in the monkey striatum using antibodies raised against the GluR6/7 and KA2 kainate receptor subunits (Fig. 2). One of the major finding of this study was that kainate receptor subunits are expressed presynaptically in glutamatergic axon terminals forming asymmetric axo-spinous and axo-dendritic synapses (Charara et al., 1999; Kieval et al., 2000) (Fig. 2A–B). To determine the source of these terminals, the anterograde transport of biotinylated dextran amine (BDA) was combined with GluR6/7 or KA2 immunostaining. Following BDA injections in the CM thalamic nucleus or the M1, more than half of anterogradely labelled boutons in the postcommissural PUT displayed GluR6/7 and KA2 immunoreactivity (Fig. 2C), which indicate that kainate receptors may act as pre-synaptic autoreceptors to control glutamate release from the thalamus and the cerebral cortex in the primate striatum. A particular feature of kainate receptor subunit immunoreactivity is their strong intracellular expression under basal conditions (Fig. 2B–D). Using pre- and post-embedding immunogold methods, most of the GluR6/7 and KA2 immunoreactivity is, indeed, associ-

ated with intracellular organelles rather than being bound to the plasma membrane (Fig. 2B–D). In immunoreactive axon terminals, kainate receptor subunit immunoreactivity is attached to the membrane of

large vesicles which, in some cases, are located in the active zone of asymmetric synapses (Fig. 2D–E). Post-synaptic labelling of asymmetric postsynaptic specializations is also seen (Fig. 2F). Although the functions

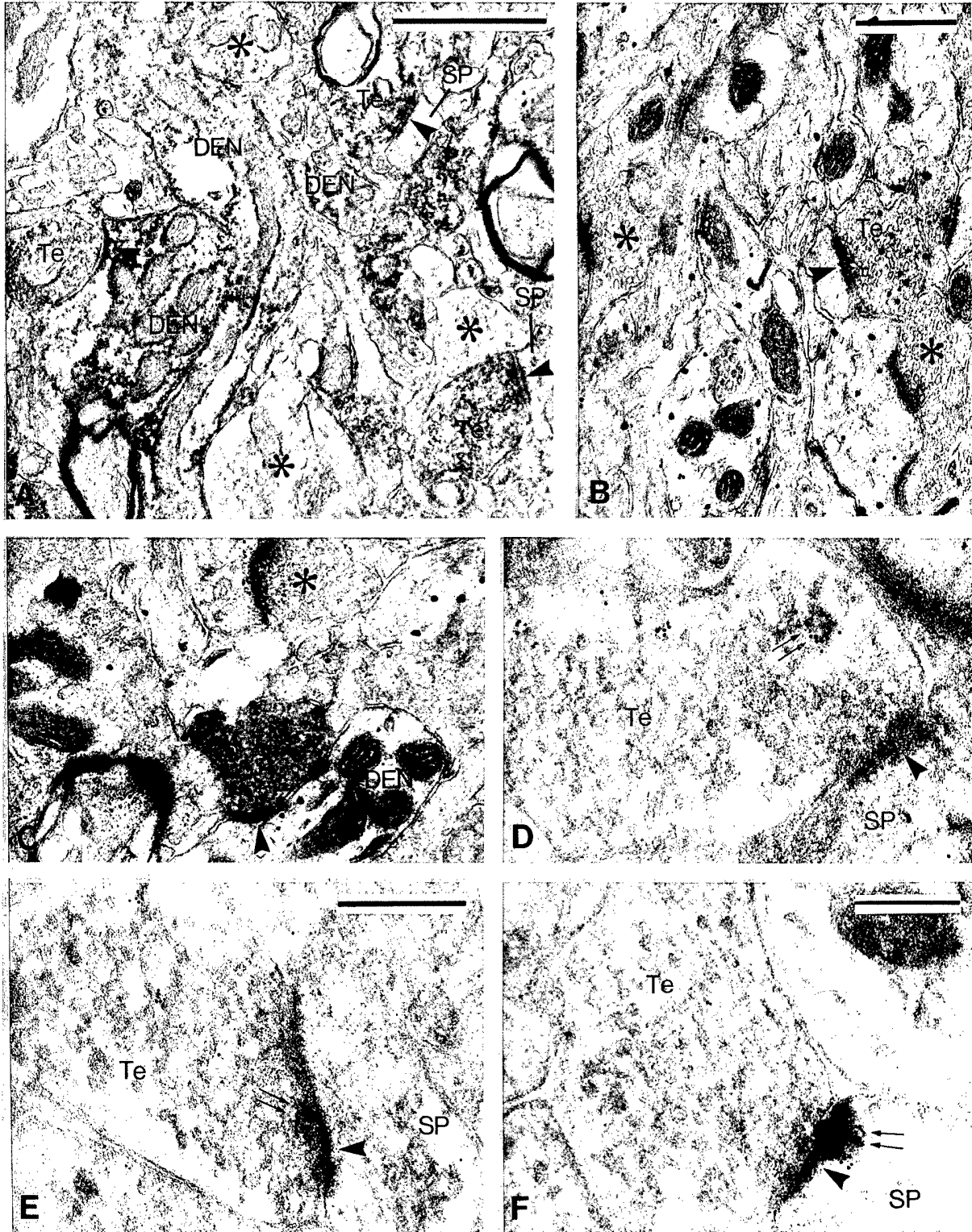

Fig. 2.

of kainate receptors in the striatum are still obscure due to the lack of specific compounds to modulate these receptors, the recent development of specific AMPA antagonists (Partenain et al., 1995) should help further our knowledge of the role of these receptors in the functional circuitry of the basal ganglia. Another promising research avenue that should definitely be explored over the next few years is the potential role of presynaptic kainate receptors in the excitotoxic phenomenon involved in the death of striatal projection neurons in Huntington's disease. The recent findings that the age of onset of Huntington's disease could, in some cases, be attributed to the genotype variation of the GluR6 kainate receptor subunit in humans strongly suggest that these receptors may, somehow, be involved in the neurodegenerative process in Huntington's patients (Rubinztin et al., 1997; MacDonald et al., 1999).

### 5.1.3. NMDA receptors

Irrespective of the approach used, all data agree that the human striatum is enriched in NMDA receptors. Ligand binding studies show dense NMDA binding sites throughout the whole extent of the CD, PUT and Acc, with a tendency to be slightly higher in the matrix than the patch compartment (Dure et al., 1992; Lee and Choi, 1992). As discussed above for the AMPA receptors, NMDA binding is affected in various brain diseases (Dure et al., 1991; Ulas et al., 1994; Noga et al., 1997; Blue et al., 1999). Data obtained in postmortem parkinsonian brains are controversial; both increases (Ulas et al., 1994) and decreases (Gerlach et al., 1996; Meoni et al., 1999) of NMDA binding sites have been reported in the CD and PUT of these patients. Despite these changes in binding density, no major difference in NMDAR1 mRNA expression is found in the striatum of parkinsonian patients (Meoni et al., 1999). On the other hand, significant reduction in NMDA binding was found in the striatum of Huntington's patients (Dure et al., 1991) whereas an increased density of NMDA receptors was reported in the PUT of schizophrenics (Aparicio-Legarza et al., 1998). Recent *in situ* hybridization data provide clear evidence for a differential distribution of various NMDA receptor subunits among the two populations of striatal projection neurons and interneurons (Kosinski et al., 1998;

Küppenbender et al., 2000). In brief, those data indicate: (1) intense NMDAR1 and NMDAR2B signal over all striatal neurons, (2) strong NMDAR2A signal over GAD67-immunoreactive neurons, intermediate labeling over substance P-containing projection neurons, low labeling over enkephalin-positive projection neurons but no signal over somatostatinergic and cholinergic interneurons which, on the other hand, express moderate signals for NMDAR2D (3) weak NMDAR2C signal over all striatal neurons except for the moderate labeling of cholinergic interneurons and (4) low NMDAR2D labeling over GAD67- and substance P-containing neurons and no labeling over enkephalin-positive projection neurons. Furthermore, only 25% of intrastriatal dopaminergic neurons express NMDAR1 immunoreactivity in MPTP-treated monkeys (Betarbet and Greenamyre, 1999). These data highlight the fact that, although all striatal neurons express NMDA receptors, their subunit composition may significantly differ among the various neuronal populations. This provides a basis for therapeutic development aimed at targeting glutamatergic synapses associated with specific NMDA receptor subtypes in neurodegenerative diseases (see below).

### 5.2. Metabotropic glutamate receptors

As mentioned above, three main groups of mGluRs have been cloned. Antibodies have now been generated against most of these receptor subtypes which allow to study their neuronal and subsynaptic localization at the electron microscopic level. To our knowledge, data on the localization of mGluRs in the human striatum are limited to a few binding studies (Dure et al., 1991; Blue et al., 1999) and a recent immunocytochemical analysis of the distribution of mGluR2 (Phillips et al., 2000). The neuropil in both the dorsal and ventral striatum displays strong mGluR2 immunoreactivity, but no cells or recognizable neuronal processes could be seen. This supports recent data showing that mGluR2/3 immunoreactivity in the rat striatum is mostly associated with cortical axon terminals (Testa et al., 1998).

We used polyclonal antisera raised against mGluR1a and mGluR5 (a,b) to study the subsynaptic distribution of group I mGluRs in the dorsal striatum of monkeys

Fig. 2. Kainate receptor subunits in the striatum: (A) GluR6/7-immunoreactive elements in the monkey CD. Immunoreactivity is mainly associated with dendrites (DEN) and axon terminals (Te) forming asymmetric synapses (arrowheads) whereas spines (SP) are almost completely devoid of labeling. Non-immunoreactive terminals are indicated with asterisks, (B) GluR6/7-immunoreactive terminal (Te) forming an asymmetric axo-spinous synapse (arrowhead). Asterisks indicate non-immunoreactive terminals. Note the paucity of gold particles on the plasma membrane in the labeled bouton, (C) An anterogradely labeled terminal which displays GluR6/7 immunoreactivity (Te) in the monkey PUT following BDA injections in the M1. The double labelled bouton forms an asymmetric synapse (arrowhead) with an unlabelled dendrite (DEN). An unlabelled terminal is marked in the neuropil (asterisk), (D–E) Post-embedding immunogold localization of GluR6/7 immunoreactivity in the monkey PUT. In immunoreactive terminals, gold particles are associated with vesicular membrane (double arrows in D) or aggregated in the presynaptic grid of asymmetric synapses (E). The postsynaptic immunoreactivity is often associated with the postsynaptic density (double arrows) and plasma membrane of asymmetric synaptic junctions (F). Scale bars: A: 1  $\mu$ m; B: 0.5  $\mu$ m (valid for C); D: 0.3  $\mu$ m (valid for F); E: 0.5  $\mu$ m.

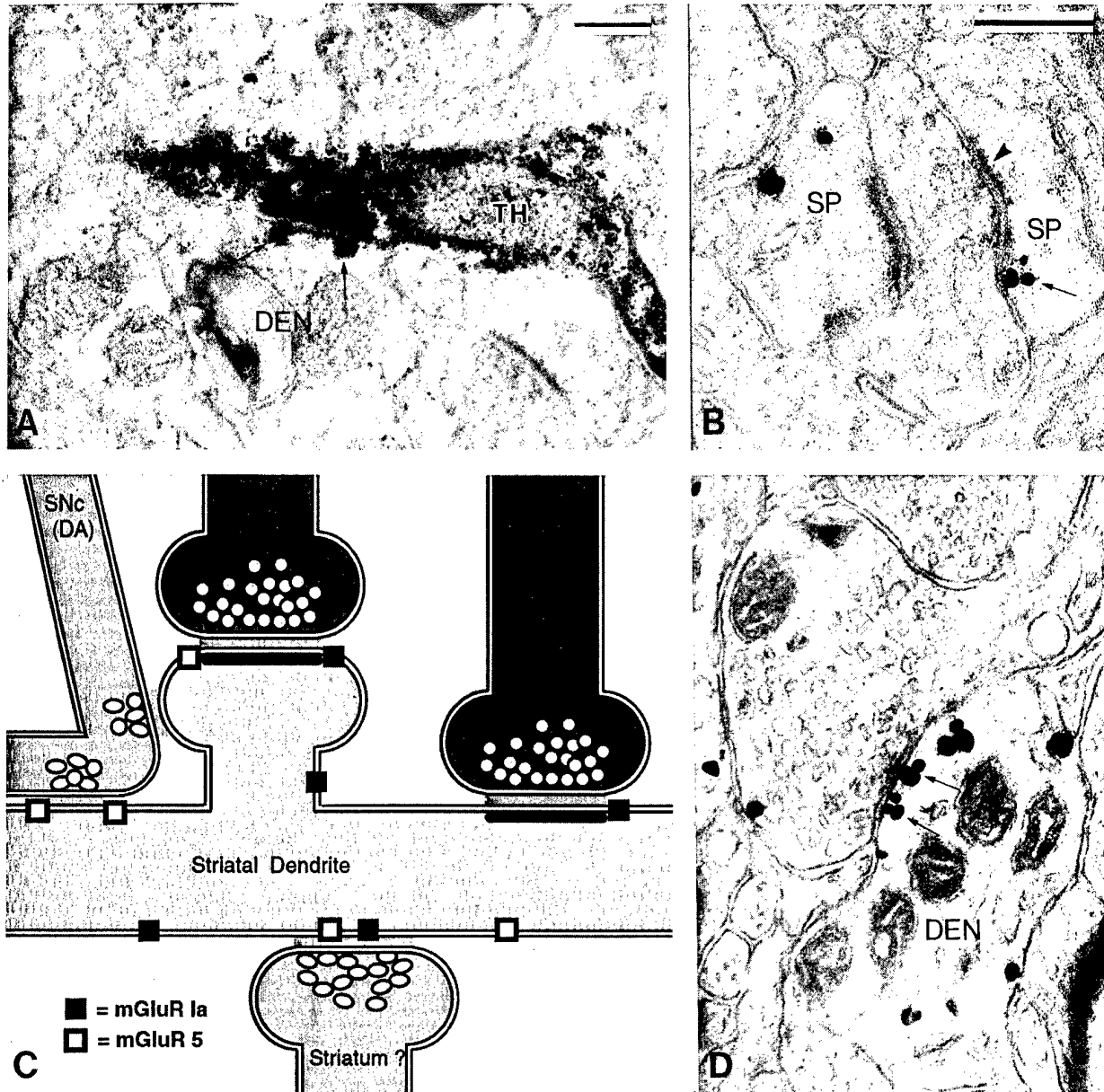

Fig. 3. Group I mGluRs in the monkey striatum: (A) mGluR5 immunoreactivity (arrows) at the edges of a symmetric axo-dendritic synapse established by a TH-positive terminal in the PUT, (B) mGluR1a immunoreactivity (arrow) at the edges of an asymmetric axo-spinous synapse (arrowhead) in the CD, (C) summary diagram of the subsynaptic localization of mGluR1a and mGluR5 immunoreactivities in dendrites and spines of striatal projection neurons in monkeys and (D) mGluR1a immunoreactivity (arrows) in the main body of a symmetric axo-dendritic synapse in the CD. Abbreviations: DA: dopamine; DEN: dendrite; Glu: glutamate; SNc: substantia nigra pars compacta; SP: spines; Thal: thalamus. Scale bars: A: 0.25  $\mu\text{m}$  (valid for D); B: 0.5  $\mu\text{m}$ .

(Fig. 3) (Smith et al., 2000a). Overall, the pattern of group I mGluRs immunoreactivity is the same in the CD and the PUT. Both medium-sized projection neurons and large interneurons display mGluR1a and mGluR5 immunoreactivities. In general, the neuropil staining is much more intense with the mGluR5 than the mGluR1a antiserum. No obvious patch/matrix pattern of distribution of immunoreactive neurons is observed with both antisera (Smith et al., 2000a). At the electron microscope level, the immunoperoxidase reac-

tion product is mostly found in post-synaptic elements including large- and small-sized perikarya with smooth or indented nuclei, dendritic processes of various sizes and dendritic spines. In addition, some axon terminals that form asymmetric axo-spinous synapses display light mGluR1a immunoreactivity, but presynaptic labelling was never encountered in mGluR5-immunostained sections (Smith et al., 2000a). In sections labeled with immunogold, both mGluR1a and mGluR5 immunoreactivities are commonly found at the edges of

asymmetric post-synaptic densities of axo-spinous and axo-dendritic synapses (Fig. 3B,C). In the mGluR5-immunostained sections, aggregates of gold particles are also associated with the main body of symmetric post-synaptic specializations established by terminals that morphologically resemble intrinsic GABAergic boutons (Fig. 3C,D). In sections double labelled for tyrosine hydroxylase (TH) and group I mGluRs, mGluR5 immunoreactivity is occasionally found perisynaptically to symmetric synapses established by TH-containing terminals (Fig. 3A,C). A large number of gold particles are also found extrasynaptic along the membrane of dendrites and spines.

So far, very little is known about the subcellular and subsynaptic localization of group II and group III mGluRs in the primate striatum. Preliminary evidence indicates that group II mGluRs are expressed presynaptically in putative glutamatergic axon terminals and postsynaptically in dendrites and spines (Paquet and Smith, 1997). On the other hand, group III mGluRs (mGluR7a and mGluR4a) are found in both GABAergic and glutamatergic boutons (Paquet and Smith, 1997). On the basis of these anatomical data, it appears that both pre and postsynaptic mGluRs may act at various sites to modulate glutamatergic, dopaminergic and GABAergic synaptic transmission in the primate striatum (Fig. 3). The expression of group II and group III mGluRs in glutamatergic terminals raises the interesting possibility of targeting these receptors to decrease the release of glutamate in Huntington's disease, thereby, protecting striatal projection neurons from excitotoxic cell death.

### 5.3. Iontropic GABA-A receptors

Central benzodiazepine receptors associated with GABA-A receptors have been classified into two subtypes, namely BZI and BZII receptors, on the basis of their pharmacology (Johnston, 1996; Mehta and Ticku, 1999). The use of selective radioactive ligands for each receptor subtype allowed to study the distribution of BZ/GABA-A receptors in the human and monkey striatum in both normal and pathological conditions. However, many studies were carried out using ligands that have the same affinity for both BZ receptor subtypes. In the description below, we will refer to either BZI or BZII receptors in cases where specific ligands were used and BZ binding sites in cases where data have been obtained with nonspecific ligands that recognize both receptor subtypes. In brief, BZ binding studies led to the following data: (1) Both receptor subtypes are significantly more abundant in the ventral than dorsal striatum (Young and Kuhar, 1979; Penney and Young, 1982; Walker et al., 1984; Faull and Villiger, 1986, 1988; Waldvogel et al., 1998, 1999), (2) In both the CD and PUT, BZI and BZII binding sites are

distributed according to the patch/matrix compartmentation in humans and monkeys (Faull and Villiger, 1986, 1988; Waldvogel et al., 1998, 1999), (3) The density of BZ binding sites is significantly decreased in the striatum of Huntington's patients (Penney and Young, 1982; Walker et al., 1984; Glass et al., 2000), (4) The density of BZ binding sites is decreased in the rostral part of the CD and PUT of MPTP-treated monkeys. This decrease remains unchanged after treatment with D1 or D2 receptor agonists (Calon et al., 1999) and (5) Continuous, but not pulsatile, administration of the D2 agonist, U91356A, in MPTP monkeys leads to a significant decrease of BZ binding sites in the striatum (Calon et al., 1995). PET imaging is another approach that has been used to study the in vivo distribution of BZ binding sites in monkey and human striatum (Brouillet et al., 1990; Moerlein and Perlmutter, 1992; Schmid et al., 1995). Results obtained so far with these methods are largely consistent with in vitro binding data.

The development of antibodies and cDNA probes raised against various GABA-A receptor subunits allowed studies of the detailed cellular localization of these subunits in the human and monkey striatum. Overall, the immunohistochemical labeling for many GABA-A receptor subunits shows a marked heterogeneous distribution, which corresponds to the patch/matrix striatal compartments, throughout the human striatum. In brief, apart from the  $\alpha 1$  subunits which are more abundant in the matrix than the patch compartment, all other subunits examined ( $\alpha 2$ ,  $\alpha 3$ ,  $\beta 2/3$ ,  $\gamma 2$ ) are expressed in both compartments but significantly more in patches than the matrix in the dorsal striatum (Waldvogel et al., 1999). The  $\alpha 1$  and  $\beta 2/3$  subunits display a similar pattern of distribution in the baboon striatum (Waldvogel et al., 1998). It is noteworthy that the pattern of compartmental expression of these receptor subunits, except for the  $\alpha 1$  subunit, is different in the ventral striatum where all subunits are preferentially expressed in the matrix compartment (Waldvogel et al., 1999). Co-localization studies using various markers of striatal neurons led to the following conclusions about GABA-A receptor subunit configurations in human striatal cells: (1) The parvalbumin/GABA interneurons are enriched in  $\alpha 1$ ,  $\beta 2/3$  and  $\gamma 2$  subunits whereas the calretinin interneurons express the same subunits but also contain high levels of the  $\alpha 3$  subunit, (2) The cholinergic interneurons only express the  $\alpha 3$  subunit, (3) The NPY-immunoreactive neurons are completely devoid of GABA-A receptor subunit immunoreactivity and (4) The calbindin-containing projection neurons express a low to moderate level of  $\alpha 2$ ,  $\alpha 3$ ,  $\beta 2/3$  and  $\gamma 2$  subunits immunoreactivity but are devoid of  $\alpha 1$  subunit labeling. In monkeys, the  $\alpha 1$  subunit is also expressed preferentially in striatal interneurons whereas the  $\beta 2/3$  subunits immunoreactivity is much more homoge-

neously distributed (Waldvogel et al., 1998). Other GABA-A receptor subunits found in the monkey striatum include the  $\alpha 4$  and  $\delta$  subunits which are expressed at high and moderate levels, respectively, in most striatal neurons (Kultas-Ilinsky et al., 1998). In contrast, the  $\beta 1$  and  $\gamma 1$  subunit mRNAs are not detectable in the monkey striatum (Kultas-Ilinsky et al., 1998). These data indicate that the subunit composition of GABA-A receptors displays a considerable degree of regional and cellular heterogeneity in the human and monkey striatum.

So far, the electron microscopic analysis of GABA-A receptor subunits in the primate striatum is limited to immunoperoxidase localization of  $\alpha 1$  and  $\beta 2/3$  subunit labeling in baboon and macaque monkeys. In both species, the GABA-A receptor subunits are expressed along the plasma membrane of striatal projection neurons and interneurons. At the subsynaptic level, peroxidase labeling was found to be associated with both symmetric and asymmetric membrane specializations as well as with nonsynaptic sites along the plasma membrane (Waldvogel et al., 1998). Further immunogold studies are essential to characterize the exact synaptic localization of GABA-A receptor subunits in the primate striatum. Recent immunogold data indicate that the  $\alpha 1$ ,  $\beta 2/3$  and  $\gamma 2$  subunit immunoreactivities are expressed postsynaptically in the main bodies of symmetric GABAergic synapses in the rat striatum (Fujiyama et al., 2000).

#### 5.4. Metabotropic GABA-B receptors

The distribution of GABA-B binding sites in the monkey basal ganglia has recently been studied using high affinity radioactive ligands ( $^3\text{HCGP}$  62349;  $^{125}\text{I-CGP}$  64213) and  $^3\text{H-GABA}$ . The striatum and the substantia nigra were found to display the highest level of GABA-B binding in the basal ganglia (Ambardekar et al., 1999; Bowery et al., 1999; Calon et al., 2000). In general, the distribution of striatal binding sites was relatively homogeneous throughout the CD, PUT and Acc. No obvious patch/matrix compartmentation of labelling was noticed. The density of striatal GABA-B binding sites is not changed in MPTP-induced parkinsonian monkeys treated with dopaminergic agonists, despite a significant decrease in the substantia nigra and increased binding in the GPi (Calon et al., 2000).

The recent cloning of two GABA-B receptor subtypes (GABA-BR1 and GABA-BR2) and the subsequent development of antibodies and mRNA probes led to a better characterization of the cellular and subcellular localization of GABA-B receptors in rat (Fritschy et al., 1999; Margeta-Mitrovic et al., 1999), monkey (Charara et al., 2000a,b) and human (Makoff, 1999; Billinton et al., 2000) brain. We recently used affinity-purified polyclonal antisera to localize immuno-

cytochemically GABA-BR1 and GABA-BR2 receptor subunits at light and electron microscope level in the monkey basal ganglia (Charara et al., 2000a,b). Overall, the pattern of labelling generated by both antisera is relatively similar throughout the primate basal ganglia, except that the intensity of labelling is generally much higher for GABA-BR1 than GABA-BR2 immunoreactivity. The similarity in distribution for both GABA-B receptor subtypes is consistent with the idea that GABA-BR1 and GABA-BR2 receptors must form heterodimers to be functional (Jones et al., 1998; Kaupmann et al., 1998; White et al., 1998; Kuner et al., 1999; Makoff, 1999).

In the striatum, the staining for both GABA-B receptor subtypes is homogeneous and relatively similar throughout the CD, PUT and Acc. Both medium-sized projection neurons and large interneurons are immunostained. In general, interneurons are more strongly labeled than projection neurons which is in keeping with recent findings showing that the GABA-BR1 immunoreactivity is particularly abundant in a small population of neurons scattered throughout the rat striatum (Margeta-Mitrovic et al., 1999). There is no patchy distribution of immunostaining, indicating that GABA-B receptor immunoreactivity is not differentially expressed in the patch-matrix compartments, which differs from the patchy distribution of some GABA-A receptor subunits in the monkey and human striatum (see above).

At the electron microscope level, the immunoperoxidase product of GABA-BR1 and GABA-BR2 is found in postsynaptic elements including large- and medium-sized cell bodies, dendrites and spines (Charara et al., 2000a,b). Occasionally, GABA-BR1 immunoreactivity is also detected in cell bodies and thin processes of astrocytes. In sections stained with the pre-embedding immunogold method, GABA-BR1 immunoreactivity was found to be localized in the main body of symmetric post-synaptic specializations established by terminal boutons packed with large pleomorphic vesicles or vesicle-filled axonal processes (Fig. 4D–E). Perisynaptic labeling at asymmetric axo-spinous and axo-dendritic synapses is also seen (Fig. 4C,E). Finally, a large number of extrasynaptic gold particles were found in neuronal perikarya, dendrites and spines (Fig. 4E). In addition to post-synaptic elements, GABA-BR1 and GABA-BR2 immunoreactivities were found in many myelinated and unmyelinated axonal segments as well as in cortical- or thalamic-like terminal boutons forming asymmetric axo-spinous and axo-dendritic synapses (Fig. 4A–B, E). In those labelled terminals, the gold particles are found in the presynaptic grid of asymmetric axospinous and axodendritic synapses (Fig. 4B). Another much rarer type of GABA-BR1-immunoreactive terminal forms “en passant” symmetric synapses with immunolabeled dendrites and display the ultra-

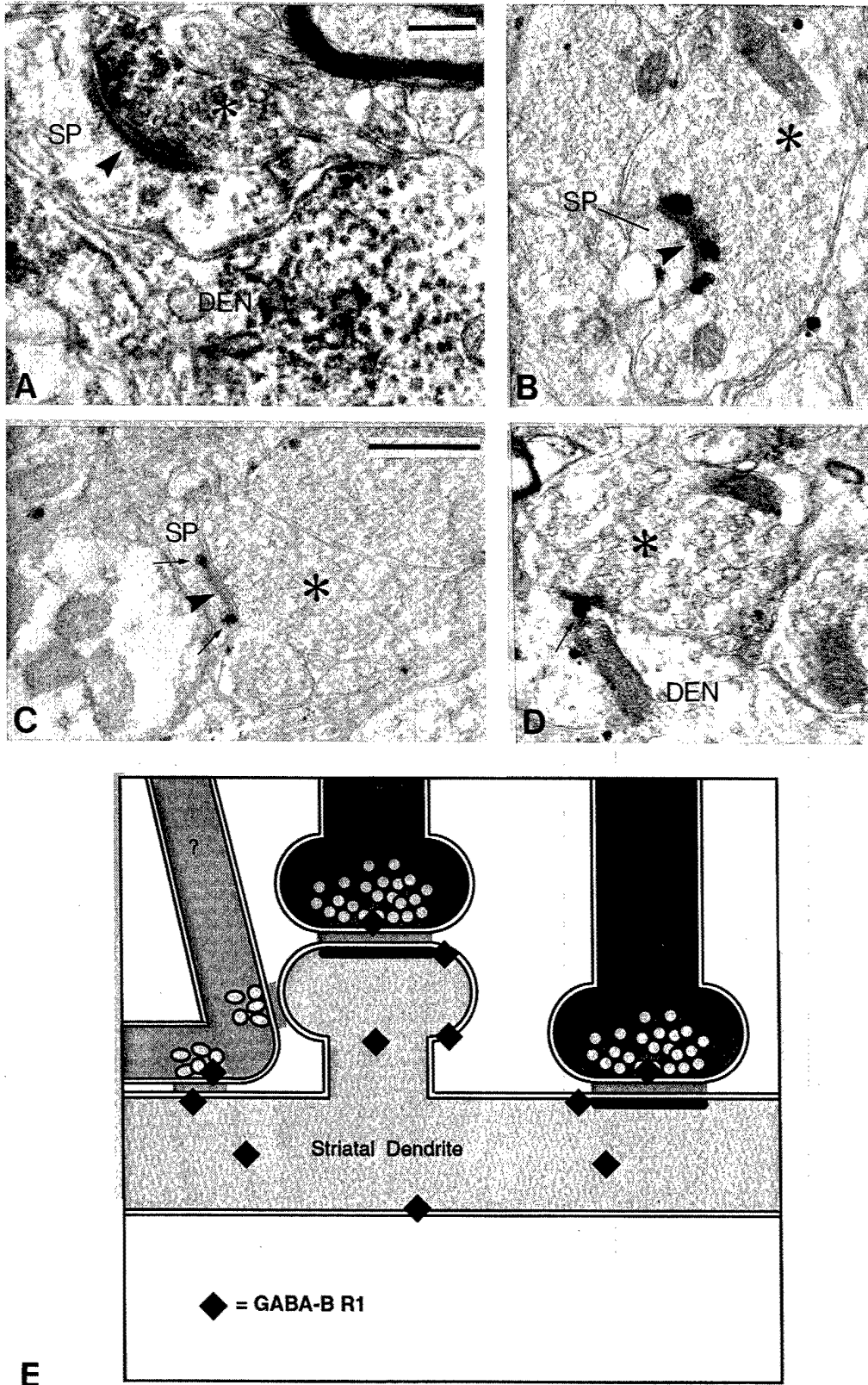

Fig. 4. GABA-BR1 receptor immunoreactivity in the monkey striatum: (A) GABA-BR1-immunoreactive terminal forming an asymmetric axo-spinous synapse (arrowhead) in the monkey PUT. An immunoreactive dendrite (Den) is in the same field, (B) GABA-BR1 (GBR1) immunogold labeling in the presynaptic grid of a putative glutamatergic terminal (asterisk) forming an asymmetric synapse (arrowhead) with a spine (SP) in the PUT, (C) postsynaptic GABA-BR1 labelling (arrows) at the edges of an asymmetric axo-spinous synapse (arrowhead), (D) postsynaptic GABA-BR1 labeling (arrow) at a symmetric axo-dendritic synapse and (E) schematic diagram to summarize the subsynaptic localization of GABA-BR1 immunoreactivity in dendrites and spines of striatal projection neurons. Scale bars: A: 0.25  $\mu\text{m}$  (valid for B); C: 0.5  $\mu\text{m}$  (valid for D).

structural features of either dopaminergic terminals from the substantia nigra or GABA-containing intrinsic striatal boutons (Charara et al., 2000a) (Fig. 4E). Although functions of GABA-B receptors are poorly known in the primate brain, it appears that these receptors are localized to subserve both pre- and post-synaptic control of GABAergic, glutamatergic and, possibly, dopaminergic neurotransmission in the monkey striatum. Functional data in various non-primate species, indeed, suggest that activation of GABA-B receptors modulate glutamatergic and dopaminergic transmission, but the exact localization of receptors which mediate these effects remains controversial (Sawynok and LaBella, 1981; Reinmann, 1983; Wilson and Wilson, 1985; Calabresi et al., 1990; Seabrook et al., 1990; Calabresi et al., 1991; Arias-Montano et al., 1992; Nisenbaum et al., 1992, 1993; Smolders et al., 1995).

## 6. Glutamate and GABA receptors in the globus pallidus

### 6.1. Ionotropic glutamate receptors

Both GPe and GPi show a relatively strong binding for various ionotropic glutamate receptor subtypes and are enriched in NMDA, AMPA and kainate receptor subunits in monkeys and humans (Lee and Choi, 1992; Bernard et al., 1996; Tomiyama et al., 1997; Blue et al., 1999). The four AMPA receptor subunits (GluR1–4) are expressed at a moderate to high level in GPe and GPi of rhesus monkeys and humans (Bernard et al., 1996; Paquet and Smith, 1996; Ciliax et al., 1997; Meng et al., 1997; Tomiyama et al., 1997; Betarbet et al., 2000) whereas only low levels of KA1 and KA2 subunits are detectable. On the other hand, the human GPi is devoid of GluR5–7 kainate receptors subunit mRNAs (Bernard et al., 1996). An interesting feature about AMPA receptors in the primate pallidum is the relative lack of GluR1 immunoreactivity in GPi neurons in the squirrel monkey (Paquet and Smith, 1996). This differs from data obtained in rhesus monkeys and humans, using the same antibodies, where all AMPA receptor subunits are strongly expressed in both pallidal segments (Bernard et al., 1996; Ciliax et al., 1997). The functional significance of this potential species difference between old world and new world primates regarding AMPA receptor subunit localization remains to be established.

Neurons in both pallidal segments are enriched in NMDAR1 and NMDAR2D subunits, but also display low level of expression of NMDAR2A,B,C in humans (Kosinski et al., 1998). In GPi, a subpopulation of neurons exhibiting low NMDAR2D mRNA signal can be easily separated from the majority of pallidal neu-

rons which display intense labelling for this subunit (Kosinski et al., 1998). Taking into account that the bulk of glutamatergic afferents to the globus pallidus arises from the STN, it is likely that both AMPA and NMDA receptors with different subunit composition are expressed at subthalamopallidal synapses in primates. Direct evidence in favor of this hypothesis has been obtained in rats (Bernard and Bolam, 1998).

Based on the functional model of basal ganglia circuitry suggesting that the STN is hyperactive in PD, one could hypothesize that this hyperactivity results in a decreased glutamate receptor expression in the pallidum. It was, indeed, recently shown that the GluR1 mRNA expression and protein levels are significantly decreased in GPi and SNr of parkinsonians (Bernard et al., 1996; Betarbet et al., 2000).

### 6.2. Metabotropic glutamate receptors

Although many studies have addressed the issue of mGluRs localization in the rodent pallidum, data in primates are much rarer and restricted to group I and group II mGluRs. In a recent light microscopic immunoperoxidase study, Phillips et al. (2000) have demonstrated that the neuropil of GPe and GPi displays a moderate to high mGluR2 immunoreactivity in humans with a slightly higher staining intensity in GPe than in GPi. In both pallidal segments, the immunoreactivity appeared to be associated with afferent fibers rather than pallidal neurons per se (Phillips et al., 2000), which suggests the existence of presynaptic group II mGluRs in the human pallidum. These data are strikingly different from those obtained in rodents which revealed low level of mGluR2 mRNAs and immunoreactivity in the rat and mouse globus pallidus (Ohishi et al., 1993; Testa et al., 1994, 1998). Whether this indicates a true species difference between rodents and primates regarding the presynaptic localization of mGluR2 in the pallidal complex or relies upon technical differences in the sensitivity of the different antibodies used in these studies remains to be established. It is worth noting that functional group II mGluRs were found to be expressed on putative STN glutamatergic terminals in the rat SNr (Bradley et al., 2000). If the intense mGluR2 immunolabeling seen in the human pallidum corresponds to presynaptic STN terminals, the group II mGluRs become a very promising target to reduce the release of glutamate from hyperactive subthalamopallidal terminals in PD. To further characterize this issue, electron microscopic studies are essential to determine the exact source of presynaptic mGluR2 labeling in the primate pallidum.

We recently carried out a detailed electron microscopic study of the subsynaptic localization of group I mGluRs (mGluR1a and mGluR5) in GPe and GPi of monkeys (Hanson and Smith, 1999; Smith et al.,

2000a). These data indicate that both receptor subtypes are largely expressed postsynaptically in neuronal elements including dendrites and perikarya. At the subsynaptic level, mGluR1a and mGluR5 immunoreactivities are found at the edges of asymmetric postsynaptic specializations of putative glutamatergic synapses (Fig. 5B–C); a pattern of labelling consistent with that found in the rat cerebellum and hippocampus (Nusser et al., 1994; Lujan et al., 1996; Ottersen and Landsend, 1997). However, a surprising observation was a strong mGluR1a and mGluR5 labelling associated with the

core of symmetric synapses established by putative GABAergic striatal terminals (Hanson and Smith, 1999) (Fig. 5A,C). A large proportion of group I mGluR labelling was also found at extrasynaptic sites along the dendrites of GPe and GPi neurons. These observations raise questions about the potential sources of glutamate that activates these receptors and their functional significance at GABAergic synapses (see below).

To our knowledge, the distribution of group III mGluRs has not yet been studied in the primate pal-

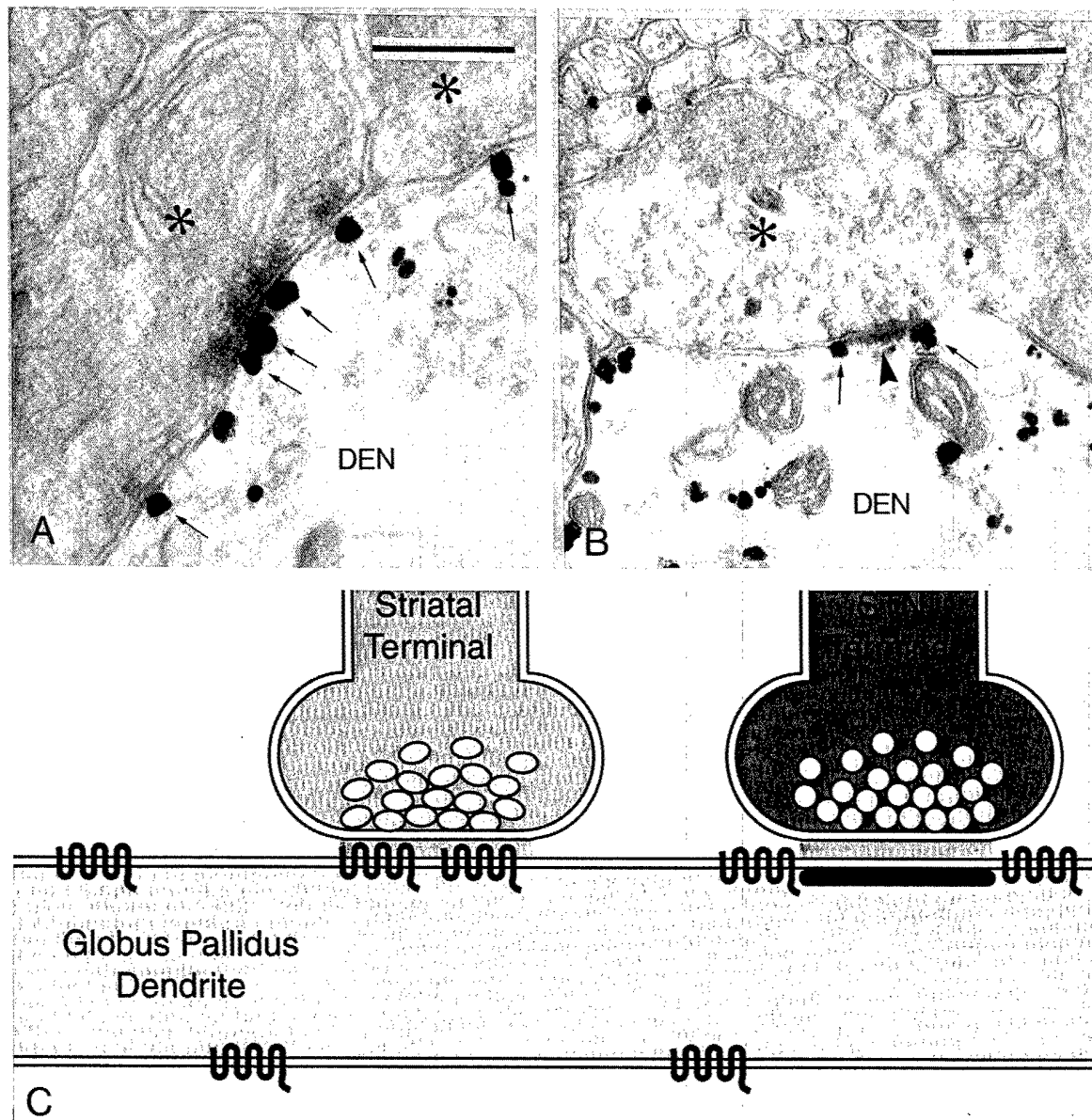

Fig. 5. Group I mGluR immunoreactivity in the monkey pallidum: (A) mGluR1a immunogold labeling (arrows) in the main body of symmetric axo-dendritic synapses established by striatal-like boutons (asterisks) in Gpi, (B) perisynaptic mGluR5 labeling (arrows) at a putative subthalampallidal asymmetric synapse (arrowhead) and (C) summary diagram to illustrate the subsynaptic localization of group I mGluRs in the monkey pallidum. Note that group I mGluRs are expressed at both symmetric and asymmetric synapses. A substantial proportion of gold labeling was also found extrasynaptically. Scale bars: A: 0.3  $\mu\text{m}$ ; B: 0.6  $\mu\text{m}$ .

lidum. However, data in rodents indicate that mGluR4a and mGluR7a,b are expressed pre-synaptically in striatopallidal terminals where they may modulate GABA release from the striatum (Kinoshita et al., 1998; Bradley et al., 1999; Kosinski et al., 1999). The fact that mGluR4a is selectively expressed on striatopallidal, but not striatonigral, terminals makes it an ideal target to reduce GABA release from the overactive striatopallidal projection in PD.

### 6.3. GABA-A receptors

Overall, the density of BZ binding sites in the primate globus pallidus is much lower than in the striatum and restricted to BZI receptor subtypes (Faull and Villiger, 1988; Waldvogel et al., 1998, 1999). The level of binding is higher in the ventral pallidum than the dorsal pallidum, and more prominent in GPe than in GPi (Faull and Villiger, 1988; Waldvogel et al., 1998, 1999). Differential changes in binding intensity between the two pallidal segments were found in postmortem brains of Huntington's patients. Whereas the GPe shows an increased binding at the very early stage of the disease, the GPi is much more strongly labelled than GPe in advanced grades of Huntington's disease (Glass et al., 2000). These data are consistent with previous findings showing that striato-GPe neurons degenerate before striato-GPi neurons in Huntington's patients (see Vonsattel and DiFiglia, 1998 for a review). The increased GABA-A binding sites might reflect a compensatory mechanism for the decrease in GABA release due to striatal cell death. Changes in pallidal BZ binding sites were also noticed in animal models of PD. MPTP-treated monkeys show an increased level of GABA/BZ binding in the GPi which could be reversed by treatment with the long acting D2 receptor agonist, cabergoline, but not by the D1 receptor agonist, SKF 82958 (Robertson et al., 1990; Calon et al., 1995, 1999). In contrast, the density of GABA/BZ binding sites is decreased in GPe after MPTP treatment (Griffiths et al., 1990; Robertson et al., 1990). This up- and down-regulation of GABA-A receptors in GPi and GPe, respectively, is consistent with the current functional model of basal ganglia circuitry which suggests that the activity of the "so-called" direct striato-GPi pathway is decreased in PD whereas the activity of the "indirect" striato-GPe projection is increased (Albin et al., 1989; DeLong, 1990).

As expected, based on their strong GABAergic innervation from the striatum (Shink and Smith, 1995), pallidal neurons are enriched in various GABA-A receptor subunits in primates and non-primates (Zhang et al., 1991; Fritschy and Möhler, 1995; Charara and Smith, 1998; Kultas-Ilinsky et al., 1998; Waldvogel et al., 1998, 1999). Using double labeling immunofluorescence techniques, Waldvogel et al. (1999) studied the

expression of various GABA-A receptor subunits in chemically characterized neurons in the human pallidum. Their main findings are: (1) Pallidal neurons are devoid of  $\alpha 2$  subunit immunoreactivity, (2) GABAergic pallidal neurons immunoreactive for parvalbumin and a subpopulation of strongly immunoreactive calretinin (CR)-containing neurons express high levels of  $\alpha 1$ ,  $\alpha 3$ ,  $\beta 2/3$  and  $\gamma 2$  immunoreactivity and (3) a subpopulation of pallidal neurons which display very intense CR immunoreactivity express  $\alpha 1$ ,  $\beta 2/3$  and  $\gamma 2$  subunit immunoreactivities. Findings in monkeys are consistent with those data except that the  $\alpha 2$  mRNA is expressed at a moderate level in GPe and GPi neurons in non-human primates (Kultas-Ilinsky et al., 1998). The lack of  $\alpha 2$  subunit in pallidal neurons seems to be a feature unique to the human pallidum since GP neurons also display  $\alpha 2$  immunoreactivity in rats (Fritschy and Möhler, 1995). It is worth noting that monkey pallidal neurons also express moderate to high level of  $\alpha 4$  and  $\delta$  subunit mRNAs, but are devoid of  $\gamma 1$  subunit (Kultas-Ilinsky et al., 1998). The  $\beta 1$  subunit mRNA is expressed at a low level in GPe but is not detectable in the monkey GPi (Kultas-Ilinsky et al., 1998). The subcellular localization of  $\alpha 1$  and  $\beta 2/3$  subunit immunoreactivity has been studied at the electron microscope level using pre-embedding immunoperoxidase methods (Charara and Smith, 1998; Waldvogel et al., 1998). Both antibodies resulted in intense labeling of the plasma membrane of GPe and GPi neurons. In some cases, aggregates of peroxidase reaction product were associated with symmetric and asymmetric post-synaptic specializations (Waldvogel et al., 1998), suggesting the existence of GABA-A receptor subunits at both GABAergic and putative glutamatergic synapses. Strong labeling was also found at non-synaptic sites along the plasma membrane. To further characterize the subsynaptic localization of the GABA-A receptor subunits in the monkey pallidum, we started a series of electron microscopic post-embedding immunogold studies of  $\alpha 1$ ,  $\beta 2/3$  and  $\gamma 2$  subunits immunoreactivity in rhesus monkeys. So far, our data indicate that the  $\alpha 1$  and  $\beta 2/3$  subunit immunoreactivity is confined to the main body of symmetric synapses (Fig. 6A, Fig. 7), which is consistent with recent data in rodents using the same approach (Somogyi et al., 1996; Fujiyama et al., 1998).

### 6.4. GABA-B receptors

Low to moderate levels of GABA-B binding sites are expressed in both pallidal segments in normal monkeys (Ambardekar et al., 1999; Bowery et al., 1999). After MPTP treatment, the level of GABA-B receptors is significantly increased in GPi, but no changes are seen in GPe, striatum and SNr (Calon et al., 2000). The increase in GPi is not affected by treatment with D1

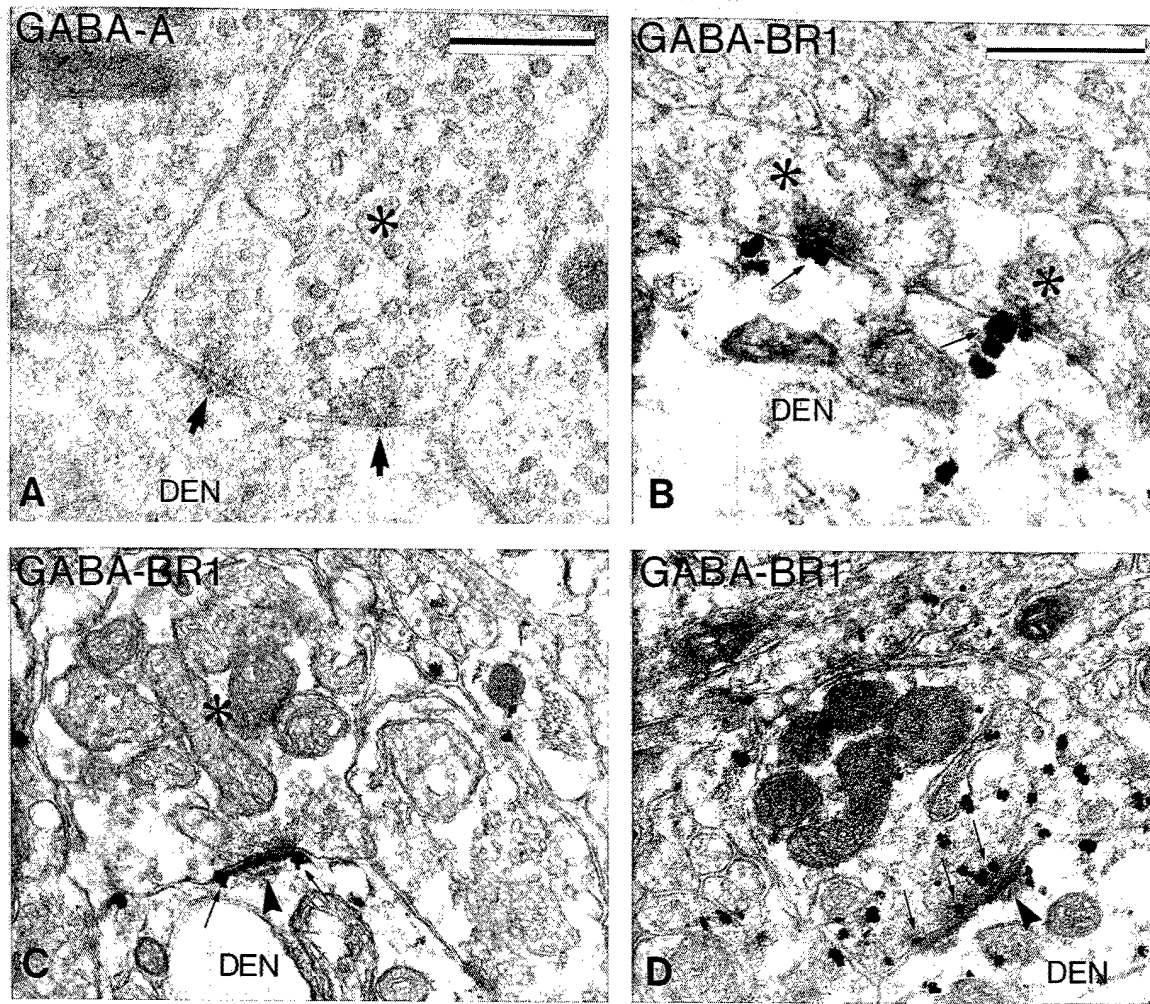

Fig. 6. GABA-A and GABA-B receptors in the monkey pallidum: (A) GABA-A receptor  $\alpha 1$  subunit immunoreactivity in the main body of a symmetric synapse (small arrows) established by a striatal-like bouton (asterisk), (B) postsynaptic GABA-BR1 immunoreactivity (small arrows) at symmetric synapses established by putative striatal boutons (asterisks), (C) postsynaptic labelling (arrows) at the edges of an asymmetric synapse established by a STN-like bouton in GPI (asterisk) and (D) presynaptic immunogold labeling of a STN-like bouton in GPI. Note that some gold particles are located in the presynaptic grid of the asymmetric synapse (arrows), but the majority of labeling is intracellular. Scale bars: A: 0.3  $\mu\text{m}$ ; B: 0.5  $\mu\text{m}$  (valid for C–F).

dopamine receptor agonist, but is partly reversed by cabergoline, a potent D2 dopamine receptor agonist (Calon et al., 2000).

Recent immunohistochemical studies revealed the existence of both GABA-BR1 and GABA-BR2 receptor subunit immunoreactivity in virtually all pallidal neurons in humans (Billinton et al., 2000) and monkeys (Charara et al., 2000a,b). Overall, the pattern of both GABA-B receptor subtypes is the same throughout GPe and GPi except that the intensity of labelling for GABA-BR1 is much stronger than that of GABA-BR2.

At the electron microscope level, GABA-BR1 and GABA-BR2 immunoreactivity is enriched in post-synaptic neuronal elements including perikarya and dendritic shafts of various sizes (Charara et al., 2000a,b). At the subsynaptic level, GABA-BR1 immunoreactivity is commonly found in the main body of

symmetric synapses established by striatal-like GABAergic terminals in both GPe and GPi or at the edges of asymmetric post-synaptic specializations of axo-dendritic synapses (Fig. 6B–C, Fig. 7). Extrasynaptic labeling is also detected in neuronal perikarya and dendrites. The most striking feature of GABA-BR1 and GABA-BR2 immunoreactivity in the GPe and GPi is the pre-synaptic labeling of numerous unmyelinated axonal segments and putative STN-like glutamatergic terminals forming asymmetric synapses (Charara et al., 2000a,b) (Fig. 6D, Fig. 7), suggesting that GABA-B act as heteroreceptors to modulate glutamate release in the globus pallidus. Another population of lightly labeled terminals that display the ultrastructural features of striatal boutons and form symmetric axo-dendritic synapses also display GABA-BR1 and GABA-BR2 immunoreactivity in both pallidal segments.

## 7. Glutamate and GABA receptors in the subthalamic nucleus

### 7.1. Ionotropic and metabotropic glutamate receptors

Very little is known about ionotropic glutamate receptor localization in the primate STN. Binding studies indicate that NMDA, AMPA and kainate receptors are expressed at a low to moderate level in this brain region in humans (Lee and Choi, 1992; Ball et al., 1994). Immunocytochemical studies revealed the existence of strong neuronal labeling for the AMPA GluR1 subunit in monkeys (Ciliax et al., 1997). Nigrostriatal dopaminergic denervation does not induce significant changes in GluR1 protein expression in STN neurons of MPTP-treated monkeys (Betarbet et al., 2000). Although immunohistochemical studies of other ionotropic glutamate receptor subunits have not been carried out in the primate STN, data in rodents indicate that various types of NMDA, AMPA and kainate receptor subunits are expressed in this brain structure (Petralia and Wenthold, 1992; Standaert et al., 1994; Petralia et al., 1994a,b; Bischoff et al., 1997). At the subsynaptic level, AMPA and NMDA receptor subunits are co-expressed in the core of asymmetric synapses, though some of the AMPA GluR2/3 immunoreactivity is also associated with non-synaptic sites and symmetric synaptic junctions in rats (Clarke and Bolam, 1998). Such information has not yet been gathered in primates.

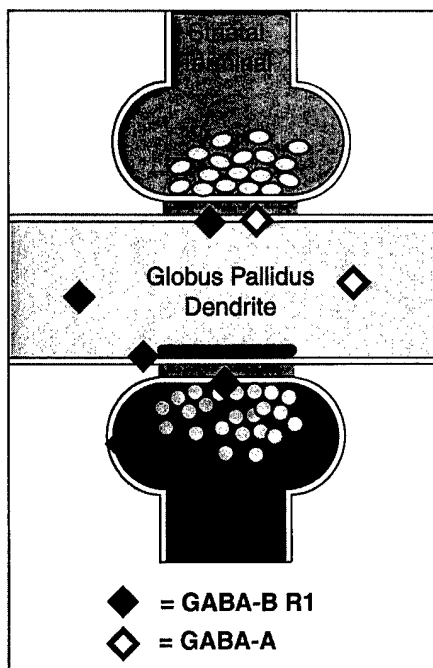

Fig. 7. Summary diagram to illustrate the subsynaptic localization of GABA-A and GABA-BR1 immunoreactivity in the monkey pallidum.

Group I and group II mGluRs are expressed in the primate STN. Immunoreactivity for mGluR2 is far less intense in the STN than other parts of the basal ganglia in humans (Phillips et al., 2000). This is surprising since STN neurons show high levels of mGluR2 mRNA expression in the rat (Testa et al., 1994). Although neuronal perikarya are lightly labeled, the neuropil of the STN displays strong immunoreactivity for both mGluR1a and mGluR5 in monkeys. At the electron microscope level, both group I mGluRs are found almost exclusively in post-synaptic elements. Immunogold particles are commonly found at the edges of symmetric and asymmetric post-synaptic specializations (Fig. 8A,C). Interestingly, labelling is also found at the edges of puncta adherentia between putative GABAergic GPe terminals and STN dendrites (Fig. 8D). In some cases, gold particles are associated with the main body of "en passant type" symmetric synapses established by vesicle-filled axon-like processes or at adherent junctions between putative glial processes and neuronal structures (Fig. 8B,D). Extrasynaptic labeling is frequently found for both receptor subtypes. The group III mGluRs localization has not been studied in primates, but *in situ* hybridization and immunocytochemical data indicate that the mGluR4 and mGluR7 expression is very low in the rat STN (Ohishi et al., 1995; Bradley et al., 1999; Kosinski et al., 1999).

### 7.2. Ionotropic and metabotropic GABA receptors

In the monkey, STN neurons express high level of mRNA for the  $\alpha 1$ ,  $\alpha 3$ ,  $\beta 2$ ,  $\beta 3$ ,  $\gamma 2$  and  $\delta$  subunits of the GABA-A receptors, but are devoid of  $\alpha 2$ ,  $\alpha 4$ ,  $\beta 1$  and  $\gamma 1$  subunits (Kultas-Ilinsky et al., 1998). A recent study showed that the human STN is particularly enriched in the  $\epsilon$  subunit (Davies et al., 1997). Although STN neurons also display strong immunoreactivity for various GABA-A receptor subunits in rats and monkeys (Zhang et al., 1991; Wisden et al., 1992; Fritschy and Möhler, 1995; Charara and Smith, 1998), there is some discrepancy between rodents and primates regarding the type of GABA-A receptor subunits expressed in this nucleus. For instance, the  $\alpha 2$  subunit immunoreactivity is abundant in rat STN neurons whereas the mRNA encoding this subunit is not detectable in the monkey STN. In contrast, the  $\delta$  subunit mRNA is abundant in the monkey STN but the immunoreactivity for this protein does not reach a detectable level in rats (Fritschy and Möhler, 1995). Whether these data indicate a real species difference in the subunit composition of GABA-A receptors between rodents and primates remains to be established.

STN neurons display low to moderate immunoreactivity for GABA-BR1 and GABA-BR2 subtypes in monkey and human STN (Billinton et al., 2000; Charara et al., 2000a,b). At the electron microscope

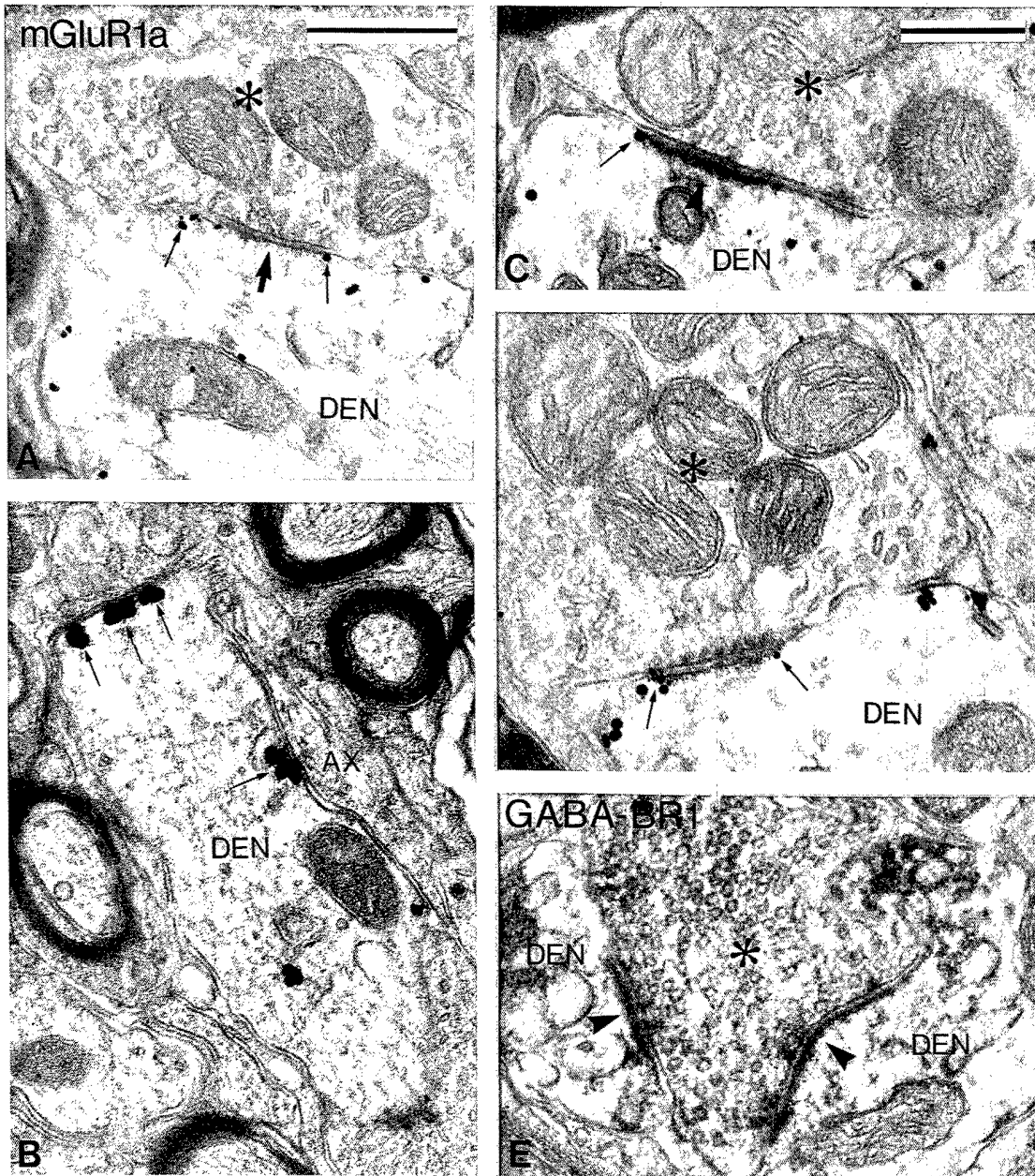

Fig. 8. Group I mGluRs and GABA-B receptor immunoreactivity in the STN: (A) mGluR1a labeling (small arrows) at the edges of a symmetric axo-dendritic synapse (arrows), (B) mGluR1a immunoreactivity at a "en passant" type symmetric synapse established by a vesicle-filled axon-like process (AX). Aggregates of gold particles at extrasynaptic sites along the labeled dendrite are not shown in these micrographs. (C–D) mGluR1a immunoreactivity at the edges of an asymmetric postsynaptic specialization (C) or a puncta adherentia between a putative GABAergic GPe terminal and a dendrite (D) and (E) A GABA-BR1-immunoreactive terminal forming asymmetric synapses (arrowheads) with dendrites (DEN). Scale bars: A: 0.2  $\mu\text{m}$  (valid for B–E).

level, both receptor subtypes are expressed post-synaptically on dendrites of STN neurons and pre-synaptically in putative glutamatergic axon terminals in monkeys (Charara et al. 2000a,b) (Fig. 8E). As was found in other basal ganglia structures, the GABA-BR2 immunoreactivity is far less intense than the GABA-BR1 immunostaining in the STN (Charara et al., 2000a,b).

Together, these data indicate that both GABA-A and GABA-B receptors are likely to mediate postsynaptic inhibition by GPe in STN neurons. In addition, GABA-B receptors may also control the activity of STN neurons by presynaptic inhibition of neurotransmitter release from extrinsic and/or intrinsic glutamatergic terminals.

## 8. Glutamate and GABA receptors in the substantia nigra

### 8.1. Iontropic and metabotropic glutamate receptors in midbrain dopaminergic neurons

Glutamate plays a major role in controlling the firing rate and firing pattern of midbrain dopaminergic neurons in rats (Grace and Bunney, 1984; Smith and Grace, 1992). On the other hand, glutamate may also become excitotoxic to dopaminergic neurons in PD. Although the exact mechanisms underlying this excitotoxic phenomenon still remains to be established, there is increasing evidence that an intracellular rise in calcium via NMDA receptor activation might be involved (Blandini et al., 1996). If such is the case, one would expect neurons in the VTA and dorsal tier of the SNc, which are less sensitive to neurodegeneration in PD, to express a lower level of Ca<sup>2+</sup>-permeable NMDA receptors than the highly sensitive ventral tier SNc neurons. Recent *in situ* hybridization data in humans indicate that such is not the case (Counihan et al., 1998). The levels of NMDAR1 and NMDAR2 (a–d) subunit mRNAs are not significantly different between the various midbrain dopaminergic cell groups, except that neurons of the pars lateralis express a slightly higher level of labelling for all NMDA receptor subunits examined (Counihan et al., 1998). These data also show that the NMDAR2D is, by far, the most abundant NMDAR2 subunit expressed in the different subgroups of SNc neurons. On the other hand, data in squirrel monkeys demonstrate that the NMDAR1 subunit mRNA expression is significantly higher in ventral tier SNc neurons than in the dorsal tier of the SNc and VTA (Paquet et al., 1997). Similarly, the AMPA GluR2 subunit is more abundant in ventral than dorsal SNc neurons whereas the GluR1 subunit is homogeneously distributed among midbrain dopaminergic cell groups (Paquet et al., 1997). These mRNA data are consistent with immunohistochemical findings showing that SNc and VTA dopaminergic neurons display moderate to strong immunoreactivity for the NMDAR1 and the AMPA (GluR1, GluR2/3 and GluR4) glutamate receptor subunits in monkeys (Paquet et al., 1997). However, SNc/VTA neurons are almost completely devoid of NMDAR2 A/B immunoreactivity, which is in line with recent rodent data (Standaert et al., 1994; Albers et al., 1999). At the subcellular level, the GluR1, GluR2/3 and NMDAR1 immunoreactivity is mostly associated with postsynaptic elements, though a small number of preterminal axons, axon terminals and glial cell processes are also labelled (Paquet et al., 1997).

Both group I mGluR subtypes (mGluR1a and mGluR5) are expressed in midbrain dopaminergic neurons in monkeys. Analysis of immunogold labelling at the electron microscopic level revealed that both recep-

tor subtypes are mostly expressed postsynaptically: (1) at the edges of asymmetric post-synaptic specializations (Fig. 9A), (2) in the main body of symmetric, putative GABAergic, synapses (Fig. 9B) and (3) extrasynaptically along the neuronal plasma membrane. A major difference between the subcellular distribution of mGluR5 and mGluR1a immunoreactivity is that a large part of mGluR1a labelling is bound to the plasma membrane whereas most mGluR5 immunostaining is intracellular. This differential distribution seems to be a common feature for the two group I mGluR subtypes in both SNr and SNc in rats and monkeys (Hubert and Smith, 1999). The functional significance of this large internalized pool of mGluR5 under basal conditions remains to be established. The dopaminergic neurons do not show any detectable mGluR2 immunoreactivity in the human substantia nigra (Phillips et al., 2000). Although group III mGluR localization has not been studied in the primate SN, recent data indicate that both SNc and SNr neurons do not express detectable levels of mGluR4 and mGluR7 immunoreactivity or mRNAs in rats (Ohishi et al., 1995; Bradley et al., 1999; Kosinski et al., 1999).

### 8.2. GABA-A and GABA-B receptors in midbrain dopaminergic neurons

Midbrain dopaminergic neurons in the SNc express varying degrees of GABA-A receptor subunits in monkeys. The  $\alpha$ 1 and  $\alpha$ 2 subunits are expressed at a low level whereas the  $\alpha$ 3,  $\alpha$ 4,  $\beta$ 1,  $\beta$ 2,  $\beta$ 3,  $\gamma$ 2 and  $\delta$  are much more abundant. It is worth noting that only SNc neurons express the  $\beta$ 1 subunit mRNA in monkey basal ganglia (Kultas-Ilinsky et al., 1998). As is the case for most basal ganglia structures, SNc neurons do not express a detectable level of  $\gamma$ 1 subunit mRNA.

The SNc displays the highest GABA-B receptor binding site densities in the monkey basal ganglia (Ambardekar et al., 1999) and expresses strong and moderate GABA-B R1 and GABA-B R2 immunoreactivity, respectively (Billinton et al., 2000; Charara et al., 2000a,b). MPTP lesion of dopaminergic neurons results in a significant loss of GABA-B binding sites in the monkey SNc, suggesting that GABA-B receptors are largely expressed on SNc neurons (Calon et al., 2000). At the electron microscopic level, immunoreactivity for both GABA-B receptor subtypes is, indeed, largely found postsynaptically in neuronal perikarya and dendrites. Rare pre-terminal axons and terminal boutons forming asymmetric synapses are occasionally labelled (Charara et al., 2000a,b) (Fig. 9C).

### 8.3. Iontropic and metabotropic glutamate receptors in SNr GABAergic neurons

The pattern of distribution of ionotropic glutamate

receptors in SNr neurons is similar to that seen in the globus pallidus. Furthermore, as is found in the monkey GPi, the expression of the AMPA receptor subunit, GluR1, is downregulated in SNr neurons of parkinsonian monkeys (Betarbet et al., 2000).

#### 8.4. GABA-A and GABA-B receptors in SNr GABAergic neurons

The pattern of GABA-A/BZ binding sites in the SNr and the expression of GABA-A receptor subunits is

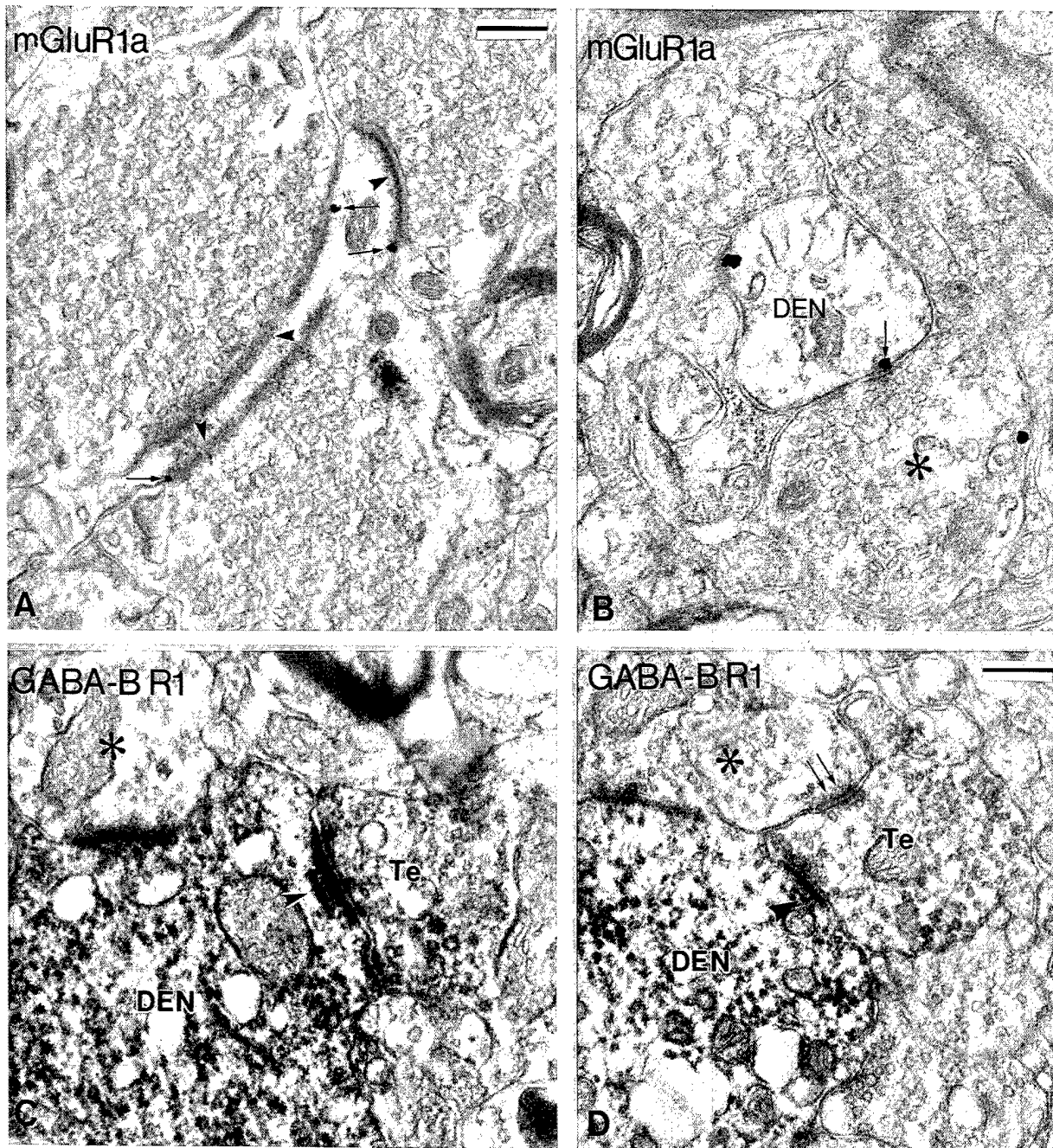

Fig. 9. Group I mGluRs and GABA-B receptors in monkey SNc and SNr: (A) mGluR1a immunogold particles at the edges of asymmetric synapses on a small spine-like process in SNc, (B) mGluR1a labeling in the main body of a symmetric axo-dendritic synapse in SNr, (C) A GABA-B R1-immunoreactive axon terminal forming an asymmetric synapse with a labeled dendrite. The asterisk indicates an unlabeled bouton in contact with the same dendrite in SNc and (D) A GABA-B R1-containing terminal in asymmetric contact with an immunoreactive dendrite in the SNr. The asterisk indicates a nonimmunoreactive terminal in contact with the labeled terminal. Scale bars: A: 0.25  $\mu$ m (valid for B–C); D: 0.5  $\mu$ m.

largely similar to that in the globus pallidus (Robertson et al., 1989) (see above), except for the expression of the  $\alpha 4$  subunit mRNA which is abundant in GPi but not detectable in the monkey SNr (Kultas-Ilinsky et al., 1998). Following MPTP treatment, a significant increase in GABA-A/BZ binding sites is observed in the monkey SNr (Robertson et al., 1989), which is consistent with the hypothesis that the “direct” striatonigral GABAergic pathway is underactive in PD (DeLong, 1990). Although a detailed electron microscopic analysis of the subsynaptic localization of these receptors has not yet been carried out in primates, recent immunogold data indicate that most GABA-A receptor subunits are expressed in the core of symmetric striatonigral synapses in rats (Fujiyama et al., 1998).

In general, the SNr displays a low level of GABA-B receptor binding sites (Ambardekar et al., 1999) and is lightly labelled with GABA-BR1 and GABA-BR2 receptor antibodies in monkeys (Charara et al., 2000a,b) and humans (Billinton et al., 2000). No change in GABA-B receptor binding is seen in the SNr following MPTP treatment (Calon et al., 2000). The pattern of subcellular distribution of GABA-B receptor subtypes in the monkey SNr resembles that seen in the globus pallidus, i.e. dendrites and many preterminal unmyelinated axons as well as a population of STN-like terminals forming asymmetric synapses display GABA-BR1 and GABA-BR2 immunoreactivity (Charara et al., 2000a,b) (Fig. 9(D)). Another population of striatal-like boutons display immunoreactivity for both receptor subtypes (Charara et al., 2000a,b).

### 9. Potential sources of activation of metabotropic receptors

One of the main features which characterizes the subsynaptic localization of metabotropic glutamate and GABA receptors is their strong expression at non-synaptic sites. In fact, this pattern of distribution was also found for other types of G-protein-coupled receptors such as dopamine, muscarinic and opiate receptors (Yung et al., 1995; Svingos et al., 1997; Bernard et al., 1998; Muriel et al., 1999). These data suggest that extrasynaptic spillover of neurotransmitter or neuropeptides might be a common mechanism to activate G protein-coupled receptors in the CNS.

One of the most surprising findings presented in this review was the localization of group I mGluRs at putative GABAergic striatal synapses in GPe, GPi and SNr (Hanson and Smith, 1999). This raises questions about the sources of activation and potential functions of these receptors at GABAergic synapses. A first possible source of glutamate might be the spillover of transmitter released from glutamatergic terminals. Extrasynaptic diffusion of glutamate to activate AMPA

and NMDA receptors was, indeed, demonstrated in the rat hippocampus and cerebellum (Asztely et al., 1997; Barbour and Hausser, 1997; Kullmann and Asztely, 1998; Dzubay and Jahr, 1999). Since mGluRs display a stronger affinity for glutamate than ionotropic receptors (Conn and Pin, 1997), it is likely that even a small amount of spilled over neurotransmitter is enough to induce mGluRs activation. Another possibility is that glutamate released from astrocytes activates mGluRs located at symmetric synapses and, possibly, those located extrasynaptically. Data obtained over the past few years showing that astrocytes express various ion channels and contain glutamate receptors (Sontheimer et al., 1996; Steinhäuser and Gallo, 1996; Verkhratsky and Kettenmann, 1996; Carmignoto et al., 1998; Porter and McCarthy, 1997), have shifted the traditional concept of astrocytes as simple structural support for neurons to a view in which glial cells play a more active role in information processing and neuronal communication in the central nervous system (Parpura et al., 1994; Antanitus, 1998). It is well established that neuronal stimulation induces waves of elevated intracellular calcium which propagate between glial cells and lead to glutamate release (Parpura et al., 1994; Araque et al., 1999). A third possibility is that striatal terminals, under certain circumstances, release excitatory amino acids. Although this is not consistent with the current view of neurotransmission at striatofugal synapses, indirect evidence suggests that striatal neurons may co-express, and possibly co-release, GABA and glutamate as neurotransmitters. First, striatopallidal neurons possess a high-affinity uptake system for glutamate and aspartate (White et al., 1994). Second, excitatory postsynaptic currents sensitive to the glutamate antagonist CNQX are found in cultures consisting only of dissociated striatal neurons (Dubinsky, 1989). Third, in vivo stimulation of the CD produces a combination of excitatory (EPSPs) and inhibitory (IPSPs) post-synaptic potentials in the rat globus pallidus (Levine et al., 1974; Kita and Kitai, 1991). Although these excitatory effects can be attributed to activation of axons extrinsic to the striatum or multisynaptic pathways, they might also originate from intrinsic striatal neurons. Even if co-release of fast neurotransmitters such as glutamate and GABA is clearly not a common feature in the CNS, the synaptic co-release of GABA and glycine was shown in the spinal cord (Jonas et al., 1998). Furthermore, Jo and Schlichter (1999) recently showed that the fast excitatory neurotransmitter ATP is co-released with the inhibitory neurotransmitter GABA at individual synapses in cultured spinal neurons. If glutamate, indeed, activates mGluRs at GABAergic synapses, it is likely that the post-synaptic mGluR responses regulate GABA currents in pallidal neurons either by changing membrane excitability through modulation of calcium and potassium channels (Conn and Pin, 1997) or via direct physical interactions with GABA-A or GABA-B

receptors as was recently shown in vitro for dopamine D5 and GABA-A receptors (Liu et al., 2000). Modulatory effects of GABAergic transmission by mGluRs were shown in various brain regions in the rat including the spinal cord, the nucleus of the solitary tract, the SNc and the hippocampus (Glaum and Miller, 1993, 1994; Bonci et al., 1997; Morishita et al., 1998).

Another surprising observation made in our studies was the localization of pre- and postsynaptic GABA-BR1 and GABA-BR2 receptors immunoreactivity associated with putative glutamatergic terminals. That axo-axonic synapses are very rare in the basal ganglia rule out the hypothesis of direct synaptic release of GABA to activate these receptors. Another possibility would be that, once released, GABA diffuses out of the synaptic cleft and activates extra- and presynaptic GABA-B heteroreceptors (Attwell et al., 1993). Evidence for such a paracrine mode of GABA-B receptor activation was, indeed, demonstrated in the rat hippocampus (Isaacson et al., 1993). The efficacy of such a non-specific mode of transmission largely depends on the extent to which GABA can diffuse and the affinity of GABA-B receptors for its transmitter. Although such information is still lacking for basal ganglia structures, it is worth noting that presynaptic GABA-B receptors were found to have a much higher affinity for GABA than GABA-A receptors in the rat hippocampus (Yoon and Rothman, 1991).

#### 10. Metabotropic glutamate and GABA-B receptors: novel therapeutic targets for Parkinson's disease

An imbalance of activity between the direct and indirect striatofugal pathways in favor of the indirect pathway is thought to underlie most symptoms of PD (DeLong, 1990). The increased activity of the glutamatergic subthalamopallidal and, possibly, corticostriatal projections in animal models of PD led various groups to test the potential therapeutic benefits of ionotropic glutamate receptor antagonists in alleviating parkinsonian symptoms (see Starr, 1995; Blandini et al., 1996 for reviews). Systemic administration of NMDA and non-NMDA antagonists with subthreshold doses of L-DOPA or D2 dopamine receptor agonist has proven to ameliorate symptoms in primate models of PD (Starr, 1995; Blandini et al., 1996). Data reported in this review strongly suggest that interactions with metabotropic glutamate and GABA-B receptors may also have beneficial effects in PD. Drugs interacting with these receptors are expected to influence the induction and progression of the symptoms of the disease without hampering the efficiency of fast glutamatergic and GABAergic synaptic transmission, thereby, reducing unwanted side effects commonly seen with drugs that target ionotropic receptors (Starr, 1995).

The group I mGluRs located perisynaptically at STN synapses in GPe and GPi should be considered as a potential target in PD because the perisynaptic mGluR1a and mGluR5 are likely to be activated by excessive amounts of glutamate released during hyperactivity of subthalamopallidal synapses in parkinsonians. Group I mGluR activation might, then, lead to increased activity of basal ganglia output neurons through various mechanisms including potentiation of ionotropic glutamatergic transmission, reduction of K<sup>+</sup> conductances etc. (see Conn and Pin, 1997 for details). Group I mGluR antagonists should, therefore, reduce the over-excitatory drive generated by the STN in pallidal neurons.

Based on rodent data, activation of the group III mGluRs, mGluR4, seems to be an ideal strategy to alleviate symptoms of PD. It is well established that activation of presynaptic group III mGluRs reduces neurotransmitter release in the hippocampus (Conn and Pin, 1997). If such is also the case in GP, activation of these receptors in parkinsonians should reduce the activity of the overactive indirect pathway by reducing GABA release at striatopallidal synapses, thereby inhibiting subthalamopallidal neurons which, in turn, relieve basal ganglia output neurons in GPi and SNr from their tonic excitatory drive. The final outcome of such therapy should be an increased activity of thalamocortical neurons and facilitation of motor behaviors.

Another mGluR subtype of interest for PD therapy is mGluR2, which was found to be expressed on subthalamonigral terminals in rats (Bradley et al., 2000). Furthermore, activation of these receptors in brain slices reduces glutamatergic transmission at subthalamonigral synapses (Bradley et al., 2000) and systemic administration of group II agonist reverses haloperidol-induced catalepsy (Bradley et al., 2000).

So far, only a few specific agents for group II (LY354740 and LY379268) and group I (MPEP) mGluRs were found to produce central pharmacological actions when administered systemically in animals (Helton et al., 1998; Moghaddam and Adams, 1998; Bordi and Ugolini, 1999; Schoepp et al., 1999). However, the potential therapeutic benefit of such agents will likely drive the development of additional compounds that could be administered systemically for novel medical purposes.

The expression of GABA-B receptors in subthalamopallidal and subthalamonigral terminals (Charara et al., 2000a,b) suggests that activation of these pre-synaptic heteroreceptors might attenuate the overflow of glutamate released by STN neurons in PD. In support of this hypothesis, application of baclofen was found to reduce the evoked synaptic currents mediated by glutamate in the rat SNr in vitro (Shen and Johnson, 1997). The current use of GABA-B agonists in therapeutics is mostly restricted to baclofen in the treatment of spastic-

ity (Porter, 1997). In fact, the beneficial antispastic effect of baclofen is believed to derive from the suppression of excitatory neurotransmitter release to motoneurons in the spinal cord (Fox et al., 1978; Davies, 1981; Bonanno et al., 1998). Future behavioural studies of baclofen in animal models should help ascertain the potential therapeutic efficacy of this drug for PD and understand better the functions of GABA-B in modulating glutamatergic neurotransmission in the basal ganglia circuitry. Interestingly, baclofen was found to reduce haloperidol-induced dyskinesias without causing gross motor depression in squirrel monkeys (Neale et al., 1984).

## 11. Concluding remarks

The data reviewed in this paper highlight the complexity of GABAergic and glutamatergic synaptic transmission in the primate basal ganglia. The rather unusual pattern of subsynaptic localization of mGluRs and GABA-B receptors in various basal ganglia structures suggests that activation of these receptors may mediate complex presynaptic heteroreceptor functions and/or induce postsynaptic receptor interactions with other neurotransmitter receptor subtypes. These observations, combined with recent evidence for the extrasynaptic diffusion of GABA and glutamate in the CNS, clearly indicate that the activation of metabotropic receptors is likely to be far more complex than the current concept of synaptic receptor activation largely based on ionotropic receptor studies. A better understanding of GABAergic and glutamatergic transmission in normal and pathological basal ganglia functions surely relies upon further analyses of the anatomical localization, physiological effects and pharmacological properties of mGluR and GABA-B receptor subtypes in the primate basal ganglia.

## Acknowledgements

The authors thank Rachel Kotys for technical assistance, Frank Kiernan for photography and Peggy Plant for clerical work. Thanks are also due to Beth Richardson for her help and advice to use the high pressure freezer. This work was supported by NIH grants R01 NS37423-01, P50 NS38399-01 and RR00165 as well as grants for the Parkinson's Disease Foundation and the US Army.

## References

- Albers, D.S., Weiss, S.W., Iadarola, M.J., Standaert, D.G., 1999. Immunohistochemical localization of *N*-methyl-D-aspartate and  $\alpha$ -amino-3-hydroxy-5-methyl-4-isoxazolepropionate receptor subunits in the substantia nigra pars compacta of the rat. *Neuroscience* 89, 209–220.
- Albin, R.L., Young, A.B., Penney, J.B., 1989. The functional anatomy of basal ganglia disorders. *Trends Neurosci.* 12, 366–375.
- Ambardekar, A.V., Ilinsky, I.A., Froestl, W., Bowery, N.G., Kultas-Ilinsky, K., 1999. Distribution and properties of GABA<sub>B</sub> antagonist [<sup>3</sup>H]CGP 62349 binding in the rhesus monkey thalamus and basal ganglia and the influence of lesions in the reticular thalamic nucleus. *Neuroscience* 93, 1339–1347.
- Antanitus, D.S., 1998. A theory of cortical neuron-astrocyte interaction. *Neuroscientist* 4, 154–159.
- Aparicio-Legarza, M.I., Davis, B., Hutson, P.H., Reynolds, G.P., 1998. Increased density of glutamate/*N*-methyl-D-aspartate receptors in putamen from schizophrenic patients. *Neurosci. Lett.* 241, 143–146.
- Araque, A., Parpura, V., Sanzgiri, R., Haydon, P.G., 1999. Tripartite synapses: glia, the unacknowledged partner. *Trends Neurosci.* 22, 208–215.
- Arias-Montano, J.A., Martinez-Fong, D., Aceves, J., 1992. GABA<sub>B</sub> receptor activation partially inhibits *N*-methyl-D-aspartate-mediated tyrosine hydroxylase stimulation in rat striatal slices. *Eur. J. Pharmacol.* 218, 335–338.
- Asztely, F., Erdemli, G., Kullmann, D.M., 1997. Extrasynaptic glutamate spillover in the hippocampus: dependence on temperature and the role of active glutamate uptake. *Neuron* 18, 281–293.
- Attwell, D., Barbour, B., Szatkowski, M., 1993. Nonvesicular release of neurotransmitter. *Neuron* 11, 401–407.
- Ball, E.F., Shaw, P.J., Ince, P.G., Johnson, M., 1994. The distribution of excitatory amino acid receptors in the normal human midbrain and basal ganglia with implications for Parkinson's disease: a quantitative autoradiographic study using [<sup>3</sup>H]glycine, [<sup>3</sup>H]CNQX and [<sup>3</sup>H]kainate. *Brain Res.* 658, 209–218.
- Barbour, B., Hausser, M., 1997. Intersynaptic diffusion of neurotransmitter. *Trends Neurosci.* 20, 377–384.
- Baude, A., Nusser, Z., Molnár, E., McIlhinney, R.A.J., Somogyi, P., 1995. High-resolution immunogold localization of AMPA type glutamate receptor subunits at synaptic and non-synaptic sites in rat hippocampus. *Neuroscience* 69, 1031–1055.
- Baude, A., Nusser, Z., Roberts, J.D., Mulvihill, E., McIlhinney, R.A., Somogyi, P., 1993. The metabotropic glutamate receptor (mGluR1 $\alpha$ ) is concentrated at perisynaptic membrane of neuronal subpopulations as detected by immunogold reaction. *Neuron* 11, 771–787.
- Bergman, H., Wichmann, T., DeLong, M.R., 1990. Reversal of experimental parkinsonism by lesions of the subthalamic nucleus. *Science* 249, 1436–1438.
- Bernard, V., Bolam, J.P., 1998. Subcellular and subsynaptic distribution of the NR1 subunit of the NMDA receptor in the neostriatum and globus pallidus of the rat: co-localization at synapses with the GluR2/3 subunit of the AMPA receptor. *Eur. J. Neurosci.* 10, 3721–3736.
- Bernard, V., Gardiol, A., Faucheux, B., Bloch, B., Agid, Y., Hirsch, E.C., 1996. Expression of glutamate receptors in the human and rat basal ganglia: effect of the dopaminergic denervation on AMPA receptor gene expression in the striatopallidal complex in Parkinson's disease and rat with 6-OHDA lesion. *J. Comp. Neurol.* 368, 553–568.
- Bernard, V., Laribi, O., Levey, A.I., Bloch, B., 1998. Subcellular redistribution of m2 muscarinic acetylcholine receptors in striatal interneurons in vivo after acute cholinergic stimulation. *J. Neurosci.* 18, 10207–10218.
- Bernard, V., Somogyi, P., Bolam, J.P., 1997. Cellular, subcellular, and subsynaptic distribution of AMPA-type glutamate receptor subunits in the neostriatum of the rat. *J. Neurosci.* 17, 819–833.

- Betarbet, R., Greenamyre, J.T., 1999. Differential expression of glutamate receptors by the dopaminergic neurons of the primate striatum. *Exp. Neurol.* 159, 401–408.
- Betarbet, R., Porter, R.H., Greenamyre, J.T., 2000. GluR1 glutamate receptor subunit is regulated differentially in the primate basal ganglia following nigrostriatal dopamine denervation. *J. Neurochem.* 74, 1166–1174.
- Bettler, B., Kaupmann, K., Bowery, N., 1998. GABA<sub>B</sub> receptors: drugs meet clones. *Curr. Opin. Neurobiol.* 8, 345–350.
- Billinton, A., Ige, A.O., Wise, A., White, J.H., Disney, G.H., Marshall, F.H., Waldvogel, H.J., Faull, R.L.M., Emson, P.C., 2000. GABA<sub>B</sub> receptor heterodimer-component localisation in human brain. *Mol. Brain Res.* 77, 111–124.
- Bischoff, S., Barhanin, J., Bettler, B., Mülle, C., Heinemann, S., 1997. Spatial distribution of kainate receptor subunit mRNA in the mouse basal ganglia and ventral mesencephalon. *J. Comp. Neurol.* 379, 541–562.
- Bittiger, H., Froestl, W., Mickel, S., Olpe, H.R., 1993. GABA<sub>B</sub> receptor antagonists: from synthesis to therapeutic applications. *Trends Pharmacol. Sci.* 14, 391–394.
- Blandini, F., Porter, H.P., Greenamyre, J.T., 1996. Glutamate and Parkinson's disease. *Mol. Neurobiol.* 12, 73–94.
- Blue, M.E., Naidu, S., Johnston, M.V., 1999. Altered development of glutamate and GABA receptors in the basal ganglia of girls with Rett syndrome. *Exp. Neurol.* 156, 345–352.
- Bolam, J.P., Hanley, J.J., Booth, P.A.C., Bevan, M.D., 2000. Synaptic organisation of the basal ganglia. *J. Anat.* 196, 527–542.
- Bonanno, G., Fassio, A., Sala, R., Schmid, G., Raiteri, M., 1998. GABA<sub>B</sub> receptors as potential targets for drugs able to prevent excessive excitatory amino acid transmission in the spinal cord. *Eur. J. Pharmacol.* 362, 143–148.
- Bonci, A., Grillner, P., Siniscalchi, A., Mercuri, N.B., Bernardi, G., 1997. Glutamate metabotropic receptor agonists depress excitatory and inhibitory transmission on rat mesencephalic principal neurons. *Eur. J. Neurosci.* 9, 143–148.
- Bonnert, T.P., McKernan, R.M., Farrar, S., Le Bourdellès, B., Heavens, R.P., Smith, D.W., Hewson, L., Rigby, M.R., Sirinathsinghji, D.J.S., Brown, N., Wafford, K.A., Whiting, P.J., 1999. Theta, a novel gamma-aminobutyric acid type A receptor subunit. *Proc. Natl. Acad. Sci. USA* 96, 9891–9896.
- Bordi, F., Ugolini, A., 1999. Group I metabotropic glutamate receptors: implications for brain diseases. *Prog. Neurobiol.* 59, 55–79.
- Bormann, J., 1997. Electrophysiology of GABA<sub>A</sub> and GABA<sub>B</sub> receptor subtypes. *Trends Neurosci.* 11, 112–116.
- Bowery, N.G., 1997. Pharmacology of mammalian GABA<sub>B</sub> receptors. In: Enna, S.J., Bowery, N.G. (Eds.), *The GABA Receptors*, second ed. Humana Press, Totowa, NJ, pp. 209–236.
- Bowery, N.G., Hill, D.R., Hudson, A.L., Doble, A., Middlemiss, D.N., Shaw, J., Turnbull, M., 1980. Baclofen decreases neurotransmitter release in the mammalian CNS by an action at a novel GABA receptor. *Nature* 283, 92–94.
- Bowery, N.G., Parry, K., Goodrich, G., Ilinsky, I., Kultas-Ilinsky, K., 1999. Distribution of GABA<sub>B</sub> binding sites in the thalamus and basal ganglia of the rhesus monkey (*Macaca mulatta*). *Neuropharmacology* 38, 1675–1682.
- Bradley, S.R., Standaert, D.G., Rhodes, K.J., Rees, H.J., Testa, C.M., Levey, A.I., Conn, P.J., 1999. Immunohistochemical localization of subtype 4a metabotropic glutamate receptors in the rat and mouse basal ganglia. *J. Comp. Neurol.* 407, 33–46.
- Bradley, S.R., Marino, M.J., Wittmann, M., Rouse, S.T., Awad, H., Levey, A.I., Conn, P.J., 2000. Activation of group II metabotropic glutamate receptors inhibits synaptic excitation of the substantia nigra pars reticulata. *J. Neurosci.* 20, 3085–3094.
- Brouillet, E., Chavoix, C., Khalili-Varasteh, M., Bottlaender, M., Hantraye, P., Yorke, J.C., Maziere, M., 1990. Quantitative evaluation of benzodiazepine receptors in live *Papio papio* baboons using positron emission tomography. *Mol. Pharmacol.* 38, 445–450.
- Brown, R.G., Marsden, C.D., 1984. How common is dementia in Parkinson's disease? *Lancet* 2, 1262–1265.
- Brown, R.G., Marsden, C.D., 1988. Subcortical dementia: the neurophysiological evidence. *Neuroscience* 25, 363–387.
- Calabresi, P., Mercuri, N.B., Demurtas, M., Bernardi, G., 1990. Endogenous GABA mediates presynaptic inhibition of spontaneous and evoked excitatory synaptic potentials in the rat neostriatum. *Neurosci. Lett.* 118, 99–102.
- Calabresi, P., Mercuri, N.B., Demurtas, M., Bernardi, G., 1991. Involvement of GABA systems in feedback regulation of glutamate- and GABA-mediated synaptic potentials in rat neostriatum. *J. Neurophysiol.* 440, 581–599.
- Calon, F., Goulet, M., Blanchet, P.J., Martel, J.C., Piercey, M.F., Bedard, P.J., Di Paolo, T., 1995. Levodopa or D2 agonist induced dyskinesia in MPTP monkeys: correlation with changes in dopamine and GABA<sub>A</sub> receptors in the striatopallidal complex. *Brain Res.* 680, 43–52.
- Calon, F., Morissette, M., Goulet, M., Grondin, R., Blanchet, P.J., Bédard, P.J., Di Paolo, T., 1999. Chronic D1 and D2 dopaminomimetic treatment of MPTP-denervated monkeys: effects on basal ganglia GABA<sub>A</sub>/benzodiazepine receptor complex and GABA content. *Neurochem. Int.* 35, 81–91.
- Calon, F., Morissette, M., Goulet, M., Grondin, R., Blanchet, P.J., Bédard, P.J., Di Paolo, T., 2000. <sup>125</sup>I-CGP 64213 binding to GABA<sub>B</sub> receptors in the brain of monkeys: effect of MPTP and dopaminomimetic treatments. *Exp. Neurol.* 163, 191–199.
- Carmignoto, G., Pasti, L., Pozzan, T., 1998. On the role of voltage-dependent calcium channels in calcium signaling of astrocytes in situ. *J. Neurosci.* 18, 4637–4645.
- Cartmell, J., Schoepp, D.D., 2000. Regulation of neurotransmitter release by metabotropic glutamate receptors. *J. Neurochem.* 75, 889–907.
- Charara, A., Blankstein, E., Smith, Y., 1999. Presynaptic kainate receptors in the monkey striatum. *Neuroscience* 91, 1195–1200.
- Charara, A., Heilman, C., Levey, A.I., 2000a. Pre- and post-synaptic GABA<sub>B</sub> receptors in the basal ganglia in monkeys. *Neuroscience* 95, 127–140.
- Charara, A., Smith, Y., 1998. Subsynaptic distribution of GABA<sub>A</sub> receptor subunits in the globus pallidus and subthalamic nucleus in monkeys. *Soc. Neurosci. Abstr.* 24, 1650.
- Charara, A., Kulik, A., Shigemoto, R., Smith, Y., 2000b. Cellular and subcellular localization of GABA-*BR2* receptors in the basal ganglia in monkeys. *Soc. Neurosci. Abstr.* 26, 1980.
- Chesselet, M.-F., Delfs, J.M., 1996. Basal ganglia and movement disorders: an update. *Trends Neurosci.* 19, 417–422.
- Cicchetti, F., Beach, T.G., Parent, A., 1998. Chemical phenotype of calretinin interneurons in the human striatum. *Synapse* 30, 284–297.
- Cicchetti, F., Vinet, J., Beach, T.G., Parent, A., 1999. Differential expression of  $\alpha$ -amino-3-hydroxy-5-methyl-4-isoxazolepropionate receptor subunits by calretinin-immunoreactive neurons in the human striatum. *Neuroscience* 93, 89–97.
- Ciliax, B.J., Greenamyre, T.J., Levey, A.I., 1997. Functional biochemistry and molecular neuropharmacology of the basal ganglia and motor systems. In: Watts, R.L., Koller, W.C. (Eds.), *Movement Disorders-Neurologic Principles and Practice*. McGraw-Hill, New York, pp. 99–116.
- Clarke, N.P., Bolam, J.P., 1998. Distribution of glutamate receptor subunits at neurochemically characterized synapses in the entopeduncular nucleus and subthalamic nucleus of the rat. *J. Comp. Neurol.* 397, 403–420.
- Conn, P.J., Pin, J.P., 1997. Pharmacology and functions of metabotropic glutamate receptors. *Ann. Rev. Pharmacol. Toxicol.* 37, 205–237.
- Counihan, T.J., Landwehrmeyer, G.B., Standaert, D.G., Kosinski, C.M., Scherzer, C.R., Daggett, L.P., Veliçelebi, G., Young, A.B., Penney, J.B. Jr., 1998. Expression of *N*-methyl-D-aspartate recep-

- tor subunit mRNA in the human brain: mesencephalic dopaminergic neurons. *J. Comp. Neurol.* 390, 91–101.
- Davies, J., 1981. Selective depression of synaptic excitation in cat spinal neurones by baclofen: an iontophoretic study. *Br. J. Pharmacol.* 72, 373–384.
- Davis, G.C., Williams, A.C., Markey, S.P., Ebert, M.H., Caine, E.D., Reichert, C.M., Kopin, I.J., 1979. Chronic parkinsonism secondary to intravenous injection of meperidine analogues. *Psychiatry Res.* 1, 249–254.
- Deisz, R.A., 1997. Electrophysiology of GABA<sub>B</sub> receptors. In: Enna, S.J., Bowery, N.G. (Eds.), *The GABA Receptors*, second ed. Humana Press, Totowa, NJ, pp. 157–207.
- DeLong, M.R., 1990. Primate models of movement disorders of basal ganglia origin. *Trends Neurosci.* 13, 281–285.
- Dubinsky, J.M., 1989. Development of inhibitory synapses among striatal neurons in vitro. *J. Neurosci.* 9, 3955–3965.
- Dure IV, L.S., Young, A.B., Penney, J.B., 1991. Excitatory amino acid binding sites in the caudate nucleus and frontal cortex of Huntington's disease. *Ann. Neurol.* 30, 785–793.
- Dure IV, L.S., Young, A.B., Penney, J.B. Jr., 1992. Compartmentalization of excitatory amino acid receptors in human striatum. *Proc. Natl. Acad. Sci. USA* 89, 7688–7692.
- Dzubay, J.A., Jahr, C.E., 1999. The concentration of synaptically released glutamate outside of the climbing fiber-Purkinje cell synaptic cleft. *J. Neurosci.* 19, 5265–5274.
- Enz, R., Brandstatter, J.H., Hartveit, E., Wassle, H., Bormann, J., 1995. Expression of GABA receptor rho 1 and rho 2 subunits in the retina and brain of the rat. *Eur. J. Neurosci.* 7, 1495–1501.
- Enz, R., Cutting, G.R., 1999. GABA<sub>C</sub> receptor  $\rho$  subunits are heterogeneously expressed in the human CNS and form homo- and heterooligomers with distinct physical properties. *Eur. J. Neurosci.* 11, 41–50.
- Faull, R.L., Villiger, J.W., 1986. Heterogeneous distribution of benzodiazepine receptors in the human striatum: a quantitative autoradiographic study comparing the pattern of receptor labelling with the distribution of acetylcholinesterase staining. *Brain Res.* 381, 153–158.
- Faull, R.L., Villiger, J.W., 1988. Multiple benzodiazepine receptors in the human basal ganglia: a detailed pharmacological and anatomical study. *Neuroscience* 24, 433–451.
- Fox, S., Krnjevic, K., Morris, M.E., Puil, E., Werman, P., 1978. Action of baclofen on mammalian synaptic transmission. *Neuroscience* 3, 495–515.
- Fritschy, J.-M., Meskenaite, V., Weinmann, O., Honer, M., Benke, D., Möhler, H., 1999. GABA<sub>B</sub>-receptor splice variants GB1a and GB1b in rat brain: developmental regulation, cellular distribution and extrasynaptic localization. *Eur. J. Neurosci.* 11, 761–768.
- Fritschy, J.-M., Möhler, H., 1995. GABA<sub>A</sub>-receptor heterogeneity in the adult rat brain: differential regional and cellular distribution of seven major subunits. *J. Comp. Neurol.* 359, 154–194.
- Froestl, W., Bettler, B., Bittiger, H., Heid, J., Kaupmann, K., Mickel, S., Strub, D., 1999. Ligands for the isolation of GABA<sub>B</sub> receptors. *Neuropharmacology* 38, 1641–1646.
- Fujiyama, F., Fritschy, J.-M., Stephenson, F.A., Bolam, J.P., 2000. Synaptic localization of GABA<sub>A</sub> receptor subunits in the striatum of the rat. *J. Comp. Neurol.* 416, 158–172.
- Fujiyama, F., Fritschy, J.-M., Stephenson, F.A., Bolam, J.P., 1998. Synaptic localization of GABA<sub>A</sub> receptor subunits in the basal ganglia in the rat. *Proceedings of the 6th International Basal Ganglia Society*, Brewster, MA, p. 16.
- Gasic, G.P., Hollmann, M., 1992. Molecular neurobiology of glutamate receptors. *Annu. Rev. Physiol.* 54, 507–536.
- Gerfen, C.R., Enber, T.M., Mahan, L.C., Susel, Z., Chase, T.N., Monsma, F.J. Jr., Sibley, D.R., 1990. D<sub>1</sub> and D<sub>2</sub> dopamine receptor-regulated gene expression of striatonigral and striatopallidal neurons. *Science* 250, 1429–1432.
- Gerfen, C.R., Wilson, C.J., 1996. The basal ganglia. In: Björklund, A., Hökfelt, T., Swanson, L. (Eds.), *Handbook of Chemical Neuroanatomy, Integrated Systems of the CNS, Part III*. Elsevier, Amsterdam, pp. 369–466.
- Gerlach, M., Gsell, W., Kornhuber, J., Jellinger, K., Krieger, V., Pantucek, F., Vock, R., Riederer, P., 1996. A postmortem study on neurochemical markers of dopaminergic, GABA-ergic and glutamatergic neurons in basal ganglia-thalamocortical circuits in Parkinson syndrome. *Brain Res.* 741, 142–152.
- Glass, M., Dragunow, M., Faull, R.L.M., 2000. The pattern of neurodegeneration in Huntington's disease: a comparative study of cannabinoid, dopamine, adenosine and GABA<sub>A</sub> receptor alterations in the human basal ganglia in Huntington's disease. *Neuroscience* 97, 505–519.
- Glaum, S.R., Miller, R.J., 1993. Activation of metabotropic glutamate receptors produces reciprocal regulation of ionotropic glutamate and GABA responses in the nucleus of the tractus solitarius of the rat. *J. Neurosci.* 13, 1636–1641.
- Glaum, S.R., Miller, R.J., 1994. Acute regulation of synaptic transmission by metabotropic glutamate receptors. In: Conn, P.J., Patel, J. (Eds.), *The Metabotropic Glutamate Receptors*. Humana Press, Totowa, NJ, pp. 147–172.
- Grace, A.A., Bunney, B.S., 1984. The control of firing pattern in nigral dopamine neurons: burst firing. *J. Neurosci.* 4, 2877–2890.
- Graybiel, A.M., 1990. Neurotransmitters and neuromodulators in the basal ganglia. *Trends Neurosci.* 13, 244–254.
- Griffiths, P.D., Sambrook, M.A., Perry, R., Crossman, A.R., 1990. Changes in benzodiazepine and acetylcholine receptors in the globus pallidus in Parkinson's disease. *J. Neurol. Sci.* 100, 131–136.
- Hanson, J.E., Smith, Y., 1999. Group I metabotropic glutamate receptors at GABAergic synapses in monkeys. *J. Neurosci.* 19, 6488–6496.
- Healy, D.J., Haroutunian, V., Powchik, P., Davidson, M., Davis, K.L., Watson, S.J., Meador-Woodruff, J.H., 1998. AMPA receptor binding and subunit mRNA expression in prefrontal cortex and striatum of elderly schizophrenics. *Neuropsychopharmacology* 19, 278–286.
- Heimer, L., Zahm, D.S., Alheid, G.F., 1995. Basal ganglia. In: Paxinos, G. (Ed.), *The Rat Nervous System*, second ed. Academic Press, San Diego, pp. 579–628.
- Helton, D.R., Tizzano, J.P., Monn, J.A., Schoepp, D.D., Kallman, M.J., 1998. Anxiolytic and side-effect profile of LY354740: a potent, highly selective, orally active agonist for group II metabotropic glutamate receptors. *J. Pharmacol. Exp. Ther.* 284, 651–660.
- Hill, D.R., Bowery, N.G., 1981. <sup>3</sup>H-Baclofen and <sup>3</sup>H-GABA bind to bicuculline-insensitive GABA<sub>B</sub> sites in rat brain. *Nature* 290, 149–152.
- Hollmann, M., Heinemann, S., 1994. Cloned glutamate receptors. *Ann. Rev. Neurosci.* 17, 31–108.
- Hoover, J.E., Strick, P.L., 1999. The organization of cerebellar and basal ganglia outputs to primary motor cortex as revealed by retrograde transneuronal transport of herpes simplex virus type 1. *J. Neurosci.* 19, 1446–1463.
- Hubert, G.W., Smith, Y., 1999. Subsynaptic localization of group I metabotropic glutamate receptors (mGluRs) in the ventral mid-brain of rats. *Soc. Neurosci. Abstr.* 25, 1156.
- Ilinsky, I.A., Jouandet, M.L., Goldman-Rakic, P.S., 1985. Organization of the nigrothalamocortical system in the rhesus monkey. *J. Comp. Neurol.* 236, 315–330.
- Ilinsky, I.A., Tourtelotte, W.G., Kultas-Ilinsky, K., 1993. Anatomical distinctions between the two basal ganglia afferent territories in the primate motor thalamus. *Stereotact. Funct. Neurosurg.* 60, 62–69.
- Inglis, W.L., Winn, P., 1995. The pedunclopontine tegmental nucleus: where the striatum meets the reticular formation. *Prog. Neurobiol.* 47, 1–29.

- Isaacson, J.S., Solis, J.M., Nicoll, R.A., 1993. Local and diffusion synaptic actions of GABA in the hippocampus. *Neuron* 10, 165–175.
- Jo, Y.-H., Schlichter, R., 1999. Synaptic corelease of ATP and GABA in cultured spinal neurons. *Nat. Neurosci.* 2, 241–245.
- Joel, D., Weiner, I., 1994. The organization of the basal ganglia-thalamocortical circuits: open interconnected rather than closed segregated. *Neuroscience* 63, 363–379.
- Joel, D., Weiner, I., 1997. The connections of the primate subthalamic nucleus: indirect pathways and the open-interconnected scheme of basal ganglia-thalamocortical circuitry. *Brain Res. Rev.* 23, 62–78.
- Johnston, G.A.R., 1996. GABA<sub>A</sub> receptor pharmacology. *Pharmacol. Ther.* 69, 173–198.
- Johnston, G.A.R., 1997. Molecular biology, pharmacology, and physiology of GABA<sub>C</sub> receptors. In: Enna, S.J., Bowery, N.G. (Eds.), *The GABA Receptors*. Humana Press, Totowa, NJ, pp. 297–323.
- Jonas, P., Bischofberger, J., Sandkuhler, J., 1998. Corelease of two fast neurotransmitters at a central synapse. *Science* 281, 419–424.
- Jones, K.A., Borowsky, B., Tamm, J.A., Craig, D.A., Durkin, M.M., Dai, M., Yao, W.J., Johnson, M., Gunwaldsen, C., Huang, L.Y., Tang, C., Shen, Q., Salon, J.A., Morse, K., Laz, T., Smith, K.E., Nagarathnam, D., Noble, S.A., Branchek, T.A., Gerald, C., 1998. GABA<sub>B</sub> receptors function as heteromeric assembly of the subunits GABA<sub>B</sub>R1 and GABA<sub>B</sub>R2. *Nature* 396, 674–679.
- Kaupmann, K., Malitschek, B., Schuler, V., Heid, J., Froesti, W., Beck, P., Mosbacher, J., Bischoff, S., Kulik, A., Shigemoto, R., Karschin, A., Bettler, B., 1998. GABA<sub>A</sub>-receptor subtypes assemble into functional heteromeric complexes. *Nature* 396, 683–687.
- Kawaguchi, Y., Wilson, C.J., Augood, S.J., Emson, P.C., 1995. Striatal interneurons: Chemical, physiological and morphological characterization. *Trends Neurosci.* 18, 527–535.
- Kerr, D.I., Ong, J., 1995. GABA<sub>B</sub> receptors. *Pharmacol. Ther.* 67, 187–246.
- Kinoshita, A., Shigemoto, R., Ohishi, H., van der Putten, H., Mizuno, N., 1998. Immunohistochemical localization of metabotropic glutamate receptors, mGluR7a and mGluR7b, in the central nervous system of the adult rat and mouse: a light and electron microscopic study. *J. Comp. Neurol.* 393, 332–352.
- Kieval, J.Z., Paré, J.-F., Smith, Y., 2000. Subcellular localization of kainate receptors in the monkey striatum. *Soc. Neurosci. Abstr.* 26, 1984.
- Kita, H., Kitai, S.T., 1991. Intracellular study of rat globus pallidus neurons: membrane properties and responses to neostriatal, subthalamic and nigral stimulation. *Brain Res.* 564, 296–305.
- Kosinski, C.M., Standaert, D.G., Coughlin, T.J., Scherzer, C.R., Kerner, J.A., Daggett, L.P., Veliçelebi, G., Penney, J.B., Young, A.B., Landwehrmeyer, G.B., 1998. Expression of *N*-methyl-D-aspartate receptor subunit mRNAs in the human brain: striatum and globus pallidus. *J. Comp. Neurol.* 390, 63–74.
- Kosinski, C.M., Bradley, S.R., Conn, P.J., Levey, A.I., Landwehrmeyer, G.B., Penney, J.B. Jr., Young, A.B., Standaert, D.G., 1999. Localization of metabotropic glutamate receptor 7 mRNA and mGluR7a protein in the rat basal ganglia. *J. Comp. Neurol.* 415, 266–284.
- Kullmann, D.M., Asztely, F., 1998. Extrasynaptic glutamate spillover in the hippocampus: evidence and implications. *Trends Neurosci.* 21, 8–14.
- Kultas-Ilinsky, K., Leontiev, V., Whiting, P.J., 1998. Expression of 10 GABA<sub>A</sub> receptor subunit messenger RNAs in the motor-related thalamic nuclei and basal ganglia of *Macaca mulatta* studied with in situ hybridization histochemistry. *Neuroscience* 85, 179–204.
- Kuner, R., Köhr, G., Grünwald, S., Eisenhardt, G., Bach, A., Kornau, H.C., 1999. Role of heteromer formation in GABA<sub>B</sub> receptor function. *Science* 283, 74–77.
- Küppenbender, K.D., Standaert, D.G., Feuerstein, T.J., Penney, J.B. Jr., Young, A.B., Landwehrmeyer, G.B., 2000. Expression of NMDA receptor subunit mRNAs in neurochemically identified projection and interneurons in the human striatum. *J. Comp. Neurol.* 419, 407–421.
- Langston, J.W., Ballard, P.A., Tetrud, J.W., Irwin, I., 1983. Chronic parkinsonism in humans due to a product of meperidine-analog synthesis. *Science* 219, 979–980.
- Lee, H., Choi, B.H., 1992. Density and distribution of excitatory amino acid receptors in the developing human fetal brain: a quantitative autoradiographic study. *Exp. Neurol.* 118, 284–290.
- Levine, M.S., Hull, C.D., Buchwald, N.A., 1974. Pallidal and entopeduncular intracellular responses to striatal, cortical, thalamic, and sensory inputs. *Exp. Neurol.* 44, 448–460.
- Levy, R., Hazrati, L.-N., Herrero, M.-T., Vila, M., Hassani, O.K., Mouroux, M., Ruberg, M., Asensi, H., Agid, Y., Féger, J., Obeso, J.A., Parent, A., Hirsch, E.C., 1997. Re-evaluation of the functional anatomy of the basal ganglia in normal and parkinsonian states. *Neuroscience* 76, 335–343.
- Liu, F., Wan, Q., Pristupa, Z.B., Yu, X.-M., Wang, Y.T., Niznik, H.B., 2000. Direct protein-protein coupling enables cross-talk between dopamine D5 and  $\gamma$ -aminobutyric acid A receptors. *Nature* 403, 274–280.
- Lujan, R., Nusser, Z., Roberts, J.D.B., Shigemoto, R., Somogyi, P., 1996. Perisynaptic location of metabotropic glutamate receptors mGluR1 and mGluR5 on dendrites and dendritic spines in the rat hippocampus. *Eur. J. Neurosci.* 8, 1488–1500.
- MacDonald, M.E., Vonsattel, J.P., Shrinidhi, J., Couropmitree, N.N., Cupples, L.A., Bird, E.D., Gusella, J.F., Myers, R.H., 1999. Evidence for the GluR6 gene associated with younger onset age of Huntington's disease. *Neurology* 53, 1330–1332.
- Macdonald, R.L., Olsen, R.W., 1994. GABA<sub>A</sub> receptor channels. *Annu. Rev. Neurosci.* 17, 569–602.
- Makoff, A., 1999. Molecular cloning of human GABA<sub>B</sub>R1 and its tissue distribution. *Mol. Brain Res.* 64, 137–140.
- Margeta-Mitrovic, M., Mitrovic, I., Riley, R.C., Jan, L.Y., Basbaum, A.I., 1999. Immunocytochemical localization of GABA<sub>B</sub> receptors in the rat central nervous system. *J. Comp. Neurol.* 405, 299–321.
- Marsden, C.D., 1984. Function of the basal ganglia as revealed by cognitive and motor disorders in Parkinson's disease. *Can. J. Neurol. Sci.* 11, 129–135.
- Martin, L.J., Blackstone, C.D., Haganir, R.L., Price, D.L., 1993. The striatal mosaic in primates: striosomes and matrix are differentially enriched in ionotropic glutamate receptor subunits. *J. Neurosci.* 13, 782–792.
- Martin, S.C., Russek, S.J., Farb, D.H., 1999. Molecular identification of the human GABABR2: cell surface expression and coupling to adenylyl cyclase in the absence of GABABR1. *Mol. Cell Neurosci.* 13, 180–191.
- Matsubara, A., Laake, J.H., Davanger, S., Usami, S.-I., Ottersen, O.P., 1996. Organization of AMPA receptor subunits at a glutamate synapse: a quantitative immunogold analysis of hair cell synapses in the rat organ of Corti. *J. Neurosci.* 16, 4457–4467.
- Mayeux, R., Chen, J., Mirabello, E., Marder, K., Bell, K., Doončief, G., Cote, L., Stern, Y., 1990. An estimate of the incidence of dementia in idiopathic Parkinson's disease. *Neurology* 40, 1513–1517.
- Mayeux, R., Denaro, J., Hemenegildo, N., Marder, K., Tang, M.X., Cote, L.J., Stern, Y., 1992. A population-based investigation of Parkinson's disease with and without dementia. Relationship to age and gender. *Arch. Neurol.* 49, 492–497.
- Mehta, A.K., Ticku, M.K., 1999. An update on GABA<sub>A</sub> receptors. *Brain Res. Rev.* 29, 196–217.
- Meng, S.Z., Obonai, T., Isumi, H., Takashima, S., 1997. A developmental expression of AMPA-selective glutamate receptor subunits in human basal ganglia. *Brain Dev.* 19, 388–392.

- Meoni, P., Bunnemann, B.H., Kingsbury, A.E., Trist, D.G., Bowery, N.G., 1999. NMDA NR1 subunit mRNA and glutamate NMDA-sensitive binding are differentially affected in the striatum and pre-frontal cortex of Parkinson's disease patients. *Neuropharmacology* 38, 625–633.
- Middleton, F.A., Strick, P.L., 2000. Basal ganglia and cerebellar loops: motor and cognitive circuits. *Brain Res. Rev.* 31, 236–250.
- Misgeld, U., Bijak, M., Jarolimek, W., 1995. A physiological role for GABA<sub>B</sub> receptors and the effects of baclofen in the mammalian central nervous system. *Prog. Neurobiol.* 46, 423–462.
- Moghaddam, B., Adams, B.V., 1998. Reversal of phencyclidine effects by group II metabotropic glutamate receptor agonists in rats. *Science* 281, 1349.
- Möhler, H., Benke, D., Benson, J., Lüscher, B., Rudolph, U., Fritschy, J.-M., 1997. Diversity in structure, pharmacology, and regulation of GABA<sub>A</sub> receptors. In: Enna, S.J., Bowery, N.G. (Eds.), *The GABA Receptors*, second ed. Humana Press, Totowa, NJ, pp. 1–36.
- Moerlein, S.M., Perlmutter, J.S., 1992. Binding of 5-(2'-[18F]fluoroethyl) flumazenil to central benzodiazepine receptors measured in living baboon by positron emission tomography. *Eur. J. Pharmacol.* 218, 109–115.
- Morishita, W., Kirov, S.A., Alger, B.E., 1998. Evidence for metabotropic glutamate receptor activation in the induction of depolarization-induced suppression of inhibition in hippocampal CA1. *J. Neurosci.* 18, 4870–4882.
- Muriel, M.P., Bernard, V., Levey, A.I., Laribi, O., Abrous, D.N., Agid, Y., Bloch, B., Hirsch, E., 1999. Levodopa induces a cytoplasmic localization of D1 dopamine receptors in striatal neurons in Parkinson's disease. *Ann. Neurol.* 46, 103–111.
- Nakanishi, S., 1994. Metabotropic glutamate receptors: synaptic transmission, modulation, and plasticity. *Neuron* 13, 1031–1037.
- Neale, R., Gerhardt, S., Liebman, J.M., 1984. Effects of dopamine agonists, catecholamine depletors, and cholinergic and GABAergic drugs on acute dyskinesia in squirrel monkeys. *Psychopharmacology* 82, 20–26.
- Nisenbaum, E.S., Berger, T.W., Grace, A.A., 1992. Presynaptic modulation by GABA<sub>B</sub> receptors of glutamatergic excitation and GABAergic inhibition of neostriatal neurons. *J. Neurophysiol.* 67, 477–481.
- Nisenbaum, E.S., Berger, T.W., Grace, A.A., 1993. Depression of glutamatergic and GABAergic synaptic responses in striatal spiny neurons by stimulation of presynaptic GABA<sub>B</sub> receptors. *Synapse* 14, 221–242.
- Noga, J.T., Hyde, T.M., Herman, M.M., Spurney, C.F., Bigelow, L.B., Weinberger, D.R., Kleinman, J.E., 1997. Glutamate receptors in the postmortem striatum of schizophrenic, suicide, and control brains. *Synapse* 27, 168–176.
- Nusser, Z., 1999. A new approach to estimate the number, density and variability of receptors at central synapses. *Eur. J. Neurosci.* 11, 745–752.
- Nusser, Z., Cull-Candy, S., Farrant, M., 1997. Differences in synaptic GABA<sub>A</sub> receptor number underlie variation in GABA mini amplitude. *Neuron* 19, 697–709.
- Nusser, Z., Mulvihill, E., Streit, P., Somogyi, P., 1994. Subsynaptic segregation of metabotropic and ionotropic glutamate receptors as revealed by immunogold localization. *Neuroscience* 61, 421–427.
- Nusser, Z., Roberts, J.D.B., Baude, A., Richards, J.G., Somogyi, P., 1995. Relative densities of synaptic and extrasynaptic GABA<sub>A</sub> receptors on cerebellar granule cells as determined by a quantitative immunogold method. *J. Neurosci.* 15, 2948–2960.
- Nusser, Z., Sieghart, W., Somogyi, P., 1998. Segregation of different GABA<sub>A</sub> receptors to synaptic and extrasynaptic membranes of cerebellar granule cells. *J. Neurosci.* 18, 1693–1703.
- Ohishi, H., Shigemoto, R., Nakanishi, S., Mizuno, N., 1993. Distribution of the messenger RNA for a metabotropic glutamate receptor, mGluR2, in the central nervous system of the rat. *Neuroscience* 53, 1009–1018.
- Ohishi, H., Akazawa, C., Shigemoto, R., Nakanishi, S., Mizuno, N., 1995. Distributions of the mRNAs for L-2-amino-4-phosphonobutyrate-sensitive metabotropic glutamate receptors, mGluR4 and mGluR7, in the rat brain. *J. Comp. Neurol.* 360, 555–570.
- Ohye, C., Kimura, M., McKenzie, J.S., 1996. *The Basal Ganglia V*. Plenum Press, New York, p. 519.
- Olpe, H.R., Karlsson, G., Pozza, M.E., Brugger, F., Steinmann, M., Van Riezen, H., Fagg, G., Hall, R.G., Froestl, W., Bittiger, H., 1990. CGP 35348: a centrally active blocker of GABA<sub>B</sub> receptors. *Eur. J. Pharmacol.* 187, 27–38.
- Ong, J., Marino, V., Parker, D.A.S., Kerr, D.I.B., Froestl, W., 1999. Pharmacological re-evaluation of a GABA<sub>B</sub> receptor antagonist CGP 47332A in rat brain. *Eur. J. Pharmacol.* 383, 137–141.
- Ottersen, O.P., Landsend, A.S., 1997. Organization of glutamate receptors at the synapse. *Eur. J. Neurosci.* 9, 2219–2224.
- Paquet, M., Smith, Y., 1996. Differential localization of AMPA glutamate receptor subunits in the two segments of the globus pallidus and the substantia nigra pars reticulata in the squirrel monkey. *Eur. J. Neurosci.* 8, 229–233.
- Paquet, M., Smith, Y., 1997. Differential distribution of metabotropic glutamate receptors (mGluRs) in the monkey striatum. *Soc. Neurosci. Abstr.* 23, 188.
- Paquet, M., Tremblay, M., Soghomonian, J.-J., Smith, Y., 1997. AMPA and NMDA glutamate receptor subunits in midbrain dopaminergic neurons in the squirrel monkey: an immunohistochemical and in situ hybridization study. *J. Neurosci.* 17, 1377–1396.
- Parent, A., Hazrati, L.-N., 1995. Functional anatomy of the basal ganglia. I. The cortico-basal ganglia-thalamo-cortical loop. *Brain Res. Rev.* 20, 91–127.
- Parpura, V., Basarsky, T.A., Liu, F., Jęftinija, S., Haydon, P.G., 1994. Glutamate-mediated astrocyte-neuron signaling. *Nature* 369, 744–747.
- Partenain, A.V., Morales, M., Lerma, J., 1995. Selective antagonism of AMPA receptors unmasks kainate receptor-mediated responses in hippocampal neurons. *Neuron* 14, 185–189.
- Penney, J.B., Young, A.B., 1982. Quantitative autoradiography of neurotransmitter receptors in Huntington's disease. *Neurology* 32, 1391–1395.
- Percheron, G., McKenzie, J.S., Féger, J., 1994. *The Basal Ganglia IV*. Plenum Press, New York, p. 616.
- Petralia, R.S., Wang, Y.-X., Wenthold, R.J., 1994a. Histological and ultrastructural localization of the kainate receptor subunits, KA2 and GluR6/7, in the rat nervous system using selective antipeptide antibodies. *J. Comp. Neurol.* 349, 85–110.
- Petralia, R.S., Wenthold, R.J., 1992. Light and electron immunocytochemical localization of AMPA-selective glutamate receptors in the rat brain. *J. Comp. Neurol.* 318, 329–354.
- Petralia, R.S., Yokotani, N., Wenthold, R.J., 1994b. Light and electron microscope distribution of the NMDA receptor subunit NMDAR1 in the rat nervous system using a selective anti-peptide antibody. *J. Neurosci.* 14, 667–696.
- Phillips, T., Rees, S., Augood, S., Waldvogel, H., Faull, R., Svendsen, C., Emson, P., 2000. Localization of metabotropic glutamate receptor type 2 in the human brain. *Neuroscience* 95, 1139–1156.
- Pin, J.-P., Duvoisin, R., 1995. Neurotransmitter receptors I. The metabotropic glutamate receptors: structure and functions. *Neuropharmacology* 34, 1–26.
- Poewe, W., Granata, R., 1997. Pharmacological treatment of Parkinson's disease. In: Watts, R.L., Koller, W.C. (Eds.), *Movement Disorders-Neurologic Principles and Practice*. McGraw-Hill, New York, pp. 201–220.
- Porter, B., 1997. A review of intrathecal baclofen in the management of spasticity. *Brit. J. Nurs.* 6, 253.

- Porter, J.T., McCarthy, K.D., 1997. Astrocytic neurotransmitter receptors in situ and in vivo. *Prog. Neurobiol.* 51, 439–455.
- Reinmann, W., 1983. Inhibition by GABA, baclofen and gabapentin of dopamine release from rabbit caudate nucleus. Are there common or different sites of action? *Eur. J. Pharmacol.* 94, 341–344.
- Robertson, R.G., Clarke, C.E., Boyce, S., Sambrook, M.A., Crossman, A.R., 1989. GABA/benzodiazepine receptors in the primate basal ganglia following treatment with MPTP: evidence for the differential regulation of striatal output by dopamine? In: Crossman, A.R., Sambrook, M.A. (Eds.), *Neural Mechanisms in Disorders of Movement*. John Libbey, London.
- Robertson, R.G., Clarke, C.E., Boyce, S., Sambrook, M.A., Crossman, A.R., 1990. The role of striatopallidal neurones utilizing gamma-aminobutyric acid in the pathophysiology of MPTP-induced parkinsonism in the primate: evidence from [<sup>3</sup>H]flunitrazepam autoradiography. *Brain Res.* 531, 95–104.
- Rouillier, E.M., Liang, F., Babalian, A., Moret, V., Wiesendanger, M., 1994. Cerebellothalamocortical and pallidothalamocortical projections to the primary and supplementary motor cortical areas: a multiple tracing study in macaque monkeys. *J. Comp. Neurol.* 345, 185–213.
- Rubinstein, D.C., Leggo, J., Chiano, M., Norbury, G., Rosser, E., Craufurd, D., 1997. Genotypes of the GluR6 kainate receptor locus are associated with variation in the age of onset of Huntington's disease. *Proc. Natl. Acad. Sci. USA* 94, 3872–3876.
- Rye, D.B., 1997. Contributions of the pedunculopontine region to normal and altered REM sleep. *Sleep* 20, 757–788.
- Sano, M., Stern, Y., Williams, J., Cote, L., Rosenstein, R., Mayeux, R., 1989. Coexisting dementia and depression in Parkinson's disease. *Arch. Neurol.* 46, 1284–1286.
- Sadikot, A.F., Smith, Y., Bolam, J.P., Parent, A., 1992a. Efferent connections of the centromedian and parafascicular thalamic nuclei in the squirrel monkey: a light and electron microscopic study of the thalamostriatal projection in relation to striatal heterogeneity. *J. Comp. Neurol.* 320, 228–242.
- Sadikot, A., Parent, A., François, C., 1992b. Efferent connections of the centromedian and parafascicular thalamic nuclei in the squirrel monkey: a PHA-L study of subcortical projections. *J. Comp. Neurol.* 315, 137–159.
- Sawynok, J., LaBella, F.S., 1981. GABA and Baclofen potentiate the K<sup>+</sup>-evoked release of methionine-enkephalin from rat slices. *Eur. J. Pharmacol.* 70, 103–110.
- Schmid, L., Bottlaender, M., Fuseau, C., Fournier, D., Brouillet, E., Maziere, M., 1995. Solpidem displays heterogeneity in its binding to the nonhuman primate benzodiazepine receptor in vivo. *J. Neurochem.* 65, 1880–1886.
- Schoepp, D.D., Jane, D.E., Monn, J.A., 1999. Pharmacological agents acting at subtypes of metabotropic glutamate receptors. *Neuropharmacology* 38, 1431–1476.
- Seabrook, G.R., Howson, W., Lacey, M.G., 1990. Electrophysiological characterization of potent agonists and antagonists at pre- and postsynaptic GABA<sub>B</sub> receptors in rat brain slices. *Br. J. Pharmacol.* 101, 949–957.
- Shen, K.Z., Johnson, S.W., 1997. Presynaptic GABA<sub>B</sub> and adenosine A1 receptors regulate synaptic transmission to rat substantia nigra reticulata neurones. *J. Physiol.* 505, 153–163.
- Shink, E., Smith, Y., 1995. Differential synaptic innervation of neurons in the internal and external segments of the globus pallidus by the GABA- and glutamate-containing terminals in the squirrel monkey. *J. Comp. Neurol.* 358, 119–141.
- Shink, E., Sidibé, M., Smith, Y., 1997. Efferent connections of the internal globus pallidus in the squirrel monkey: II. Topography and synaptic organization of pallidal efferents to the pedunculopontine nucleus. *J. Comp. Neurol.* 382, 348–363.
- Sidibé, M., Bevan, M.D., Bolam, J.P., Smith, Y., 1997. Efferent connections of the internal globus pallidus in the squirrel monkey: I. Topography and synaptic organization of the pallidothalamic projection. *J. Comp. Neurol.* 382, 323–347.
- Sidibé, M., Smith, Y., 1999. Thalamic inputs to striatal interneurons in monkeys: synaptic organization and co-localization of calcium binding proteins. *Neuroscience* 89, 1189–1208.
- Smith, Y., Parent, A., 1986. Differential connections of caudate nucleus and putamen in the squirrel monkey (*Saimiri sciureus*). *Neuroscience* 18, 347–371.
- Smith, A.D., Bolam, J.P., 1990. The neural network of the basal ganglia as revealed by the study of synaptic connections of identified neurones. *Trends Neurosci.* 13, 259–265.
- Smith, I.D., Grace, A.A., 1992. Role of the subthalamic nucleus in regulation of nigral dopamine neuron activity. *Synapse* 12, 287–303.
- Smith, Y., Bennett, B.D., Bolam, J.P., Parent, A., Sadikot, A.F., 1994. Synaptic relationships between dopaminergic afferents and cortical or thalamic input in the sensorimotor territory of the striatum in monkey. *J. Comp. Neurol.* 344, 1–19.
- Smith, Y., Bevan, M.D., Shink, E., Bolam, J.P., 1998a. Microcircuitry of the direct and indirect pathways of the basal ganglia. *Neuroscience* 86, 353–387.
- Smith, Y., Shink, E., Sidibé, M., 1998b. Neuronal circuitry and synaptic connectivity of the basal ganglia. *Neurosurg. Clin. N. Am.* 9, 203–222.
- Smith, Y., Sidibé, M., 1999. Functional interconnections between the caudal intralaminar nuclei and the striatopallidal complex in monkeys. *Soc. Neurosci. Abstr.* 25, 1925.
- Smith, Y., Charara, A., Hanson, J.E., Paquet, M., Levey, A.I., 2000a. GABA<sub>B</sub> and group I metabotropic glutamate receptors in the striatopallidal complex in primates. *J. Anat.* 196, 555–576.
- Smith, Y., Sidibé, M., Paré, J.-F., 2000b. Synaptic inputs from the substantia nigra and the pedunculopontine nucleus to thalamostriatal neurons in monkeys. *Soc. Neurosci. Abstr.* 26, 965.
- Smolders, I., De Klippel, N., Sarre, S., Ebinger, G., Michotte, Y., 1995. Tonic GABAergic modulation of striatal dopamine release studied by in vivo microdialysis in the freely moving rat. *Eur. J. Pharmacol.* 284, 83–91.
- Sontheimer, H., Black, J.A., Waxman, S.G., 1996. Voltage-gated Na<sup>+</sup> channels in glia: properties and possible functions. *Trends Neurosci.* 19, 325–331.
- Standaert, D.G., Testa, C.M., Young, A.B., Penney, J.B. Jr., 1994. Organization of N-methyl-D-aspartate glutamate receptor gene expression in the basal ganglia of the rat. *J. Comp. Neurol.* 343, 1–16.
- Starr, M.S., 1995. Glutamate/dopamine D1/D2 balance in the basal ganglia and its relevance to Parkinson's disease. *Synapse* 19, 264–293.
- Steinhauser, C., Gallo, V., 1996. News on glutamate receptors in glial cells. *Trends Neurosci.* 19, 339–345.
- Svingos, A.L., Moriwaki, A., Wang, J.B., Uhl, G.R., Pickel, V.M., 1997. Mu-opioid receptors are localized to extrasynaptic plasma membranes of GABAergic neurons and their targets in the rat nucleus accumbens. *J. Neurosci.* 17, 2585–2594.
- Testa, C.M., Friberg, I.K., Weiss, S.W., Standaert, D.G., 1998. Immunohistochemical localization of metabotropic glutamate receptors mGluR1a and mGluR2/3 in the rat basal ganglia. *J. Comp. Neurol.* 390, 5–19.
- Testa, C.M., Standaert, D.G., Young, A.B., Penney, J.B. Jr., 1994. Metabotropic glutamate receptor mRNA expression in the basal ganglia of the rat. *J. Neurosci.* 14, 3005–3018.
- Tomiya, M., Palacios, J.M., Cortés, R., Vilaró, M.T., Mengod, G., 1997. Distribution of AMPA receptor subunit mRNAs in the human basal ganglia: an in situ hybridization study. *Mol. Brain Res.* 46, 281–289.
- Ulas, J., Wehmüller, F.B., Brunner, L.C., Joyce, J.N., Marshall, J.F., Cotman, C.W., 1994. Selective increase of NMDA-sensitive glutamate binding in the striatum of Parkinson's disease, Alzheimer's

- disease, and mixed Parkinson's disease/Alzheimer's disease patients: an autoradiographic study. *J. Neurosci.* 14 (11 Pt. 1), 6317–6324.
- Upton, N., Blackburn, T., 1997. Pharmacology of mammalian GABA<sub>A</sub> receptors. In: Enna, S.J., Bowery, N.G. (Eds.), *The GABA Receptors*. Humana Press, Totowa, NJ, pp. 83–120.
- Van Lookeren Campagne, M., Oestreicher, A.B., Van der Krift, T.P., Gispen, W.H., Verkleij, A.J., 1991. Freeze-substitution and Lowicryl HM20 embedding of fixed rat brain: suitability for immunogold ultrastructural localization of neural antigens. *J. Histochem. Cytochem.* 39, 1267–1279.
- Verkhatsky, A., Kettenmann, H., 1996. Calcium signalling in glial cells. *Trends Neurosci.* 19, 346–351.
- Vitek, J.L., 1997. Stereotaxic surgery and deep brain stimulation for Parkinson's disease and movement. In: Watts, R.L., Koller, W.C. (Eds.), *Movement Disorders-Neurologic Principles and Practice*. McGraw-Hill, New York, pp. 237–256.
- Vonsattel, J.P.G., DiFiglia, M., 1998. Huntington's disease. *J. Neuropathol. Exp. Neurol.* 57, 369–384.
- Waldvogel, H.J., Fritschy, J.-M., Mohler, H., Faull, R.L.M., 1998. GABA<sub>A</sub> receptors in the primate basal ganglia: an autoradiographic and a light and electron microscopic immunohistochemical study of the  $\alpha 1$  and  $\beta 2,3$  subunits in the baboon brain. *J. Comp. Neurol.* 397, 297–325.
- Waldvogel, H.J., Kubota, Y., Fritschy, J.-M., Mohler, H., Faull, R.L.M., 1999. Regional and cellular localisation of GABA<sub>A</sub> receptor subunits in the human basal ganglia: an autoradiographic and immunohistochemical study. *J. Comp. Neurol.* 415, 313–340.
- Walker, F.O., Young, A.B., Penney, J.B., Dovorini-Kis, K., Shoulson, I., 1984. Benzodiazepine and GABA receptors in early Huntington's disease. *Neurology* 34, 1237–1240.
- Wegelius, K., Pasternack, M., Hiltunen, J.O., Rivera, C., Kaila, K., Saarna, M., Reeben, M., 1998. Distribution of GABA receptor rho subunit transcripts in the rat brain. *Eur. J. Neurosci.* 10, 350–357.
- Westbrook, G.L., 1994. Glutamate receptor update. *Curr. Opin. Neurobiol.* 4, 337–346.
- White, L.E., Hodges, H.D., Carnes, K.M., Price, J.L., Dubinsky, J.M., 1994. Colocalization of excitatory and inhibitory neurotransmitter markers in striatal projection neurons in the rat. *J. Comp. Neurol.* 339, 328–340.
- White, J.H., Wise, A., Main, M.J., Green, A., Fraser, N.J., Disney, G.H., Barnes, A.A., Emson, P., Foord, S.M., Marshall, F.H., 1998. Heterodimerization is required for the formation of a functional GABA<sub>B</sub> receptor. *Nature* 396, 679–682.
- Wichmann, T., DeLong, M.R., 1996. Functional and pathophysiological models of the basal ganglia. *Curr. Opin. Neurobiol.* 6, 751–758.
- Wilson, C.J., 1998. Basal ganglia. In: Shepherd, G.M. (Ed.), *The Synaptic Organization of the Brain*, fourth ed. Oxford University Press, New York, pp. 329–375.
- Wilson, J.S., Wilson, J.A., 1985. Baclofen attenuates hyperpolarizing not depolarizing responses of caudate neurons in cat. *Brain Res.* 342, 396–400.
- Wisden, W., Laurie, D.J., Monyer, H., Seeburg, P.H., 1992. The distribution of 13 GABA<sub>A</sub> receptor subunit mRNAs in the rat brain. I. Telencephalon, diencephalon, mesencephalon. *J. Neurosci.* 12, 1040–1062.
- Young, W., Kuhar, M.J., 1979. Autoradiographic localization of benzodiazepine receptors in the brains of humans and animals. *Nature* 280, 393–395.
- Yoon, K.-W., Rothman, S.M., 1991. The modulation of rat hippocampal synaptic conductances by baclofen and  $\gamma$ -aminobutyric acid. *J. Physiol.* 442, 377–390.
- Yung, K.K.L., Bolam, J.P., Smith, A.D., Hersch, S.M., Ciliax, B.J., Levey, A.I., 1995. Immunocytochemical localization of D1 and D2 dopamine receptors in the basal ganglia of the rat: Light and electron microscopy. *Neuroscience* 65, 709–730.
- Zhang, J.-H., Sato, M., Tohyama, M., 1991. Region-specific expression of the mRNAs encoding  $\beta$  subunits ( $\beta 1$ ,  $\beta 2$  and  $\beta 3$ ) of GABA<sub>A</sub> receptor in the rat brain. *J. Comp. Neurol.* 303, 637–657.

## **ANATOMICAL AND FUNCTIONAL RELATIONSHIPS BETWEEN INTRALAMINAR THALAMIC NUCLEI AND BASAL GANGLIA IN MONKEYS**

Mamadou Sidibé, Jean-François Paré, Dinesh Raju and Yoland Smith<sup>1</sup>

### **1. INTRODUCTION**

The basal ganglia are major telencephalic subcortical structures involved in the control of motor, cognitive and psychoaffective behaviours. In primate, these nuclei include (1) the caudate nucleus, putamen and nucleus accumbens which commonly form the striatum, (2) the globus pallidus which comprises an external (GPe) and internal segments (GPi), as well as the ventral pallidum (VP), (3) the subthalamic nucleus (STN) and (4) the substantia nigra that includes the pars compacta (SNc) which contains dopaminergic neurons, and the pars reticulata (SNr) which contains GABAergic neurons. The striatum is the largest component and the main entrance of information to the basal ganglia. It receives major excitatory inputs from the entire cerebral cortex and the thalamus.

Although both the cerebral cortex and the thalamus have long been known as the two main excitatory glutamatergic inputs to the striatum, the thalamostriatal projections have received much less attention than the corticostriatal system in the interpretation of changes of neuronal activity in the striatum induced by glutamatergic afferents (DeLong, 1990; Gerfen and Wilson, 1996; Calabresi et al., 1997). The thalamostriatal projection

---

<sup>1</sup>Yerkes Regional Primate Research Center and Dept of Neurology, Emory University, 954, Gatewood RD NE, Atlanta, GA 30322, USA

was first demonstrated in humans based on retrograde degeneration studies (Vogt and Vogt 1941; Powell and Cowan, 1956). Since then, the use of retrograde and anterograde axonal tracers helped to better understand the exact cellular origin and topographical organization of this neuronal system in different mammalian species. Recent anatomical data from our laboratory and others clearly demonstrated that the thalamostriatal projections display a high degree of functional, hodological and synaptic specificity in rats and monkeys (Groenewegen and Berendse, 1994; Smith et al., 1994; Sidibe and Smith, 1996, 1999). These observations, combined with electrophysiological data showing that the thalamostriatal projections from the caudal intralaminar nuclei play a major role in learning and conditioning processes in striatal neurons (Matsumoto et al., 2001), emphasize the potential importance of this system in the functional circuitry of the basal ganglia. For the past ten years, our laboratory has studied the synaptic organization of the thalamostriatal system in monkeys. More recently, we have paid attention to the synaptic connectivity of specific basal ganglia and brainstem afferents to thalamostriatal neurons. In this chapter, we will briefly review our main findings on this system and relate these anatomical data to the functional organization of specific basal ganglia thalamostriatal circuits in primates.

## 2. THE THALAMOSTRIATAL PROJECTIONS

### 2.1. Sources of Thalamostriatal Projections

Although the thalamostriatal projection arises from various thalamic nuclei, (Smith and Parent 1986; Groenewegen and Berendse, 1994; Gimenez-Amaya et al., 1995; McFarland and Haber, 2000, 2001), the major source of this projection is the caudal intralaminar nuclear group, namely the centromedian (CM) and the parafascicular (PF) nuclei (Smith et Parent, 1986; Dubé et al., 1988; Sadikot et al., 1992a,b). Other thalamic sources include rostral intralaminar nuclei and ventral motor nuclei (Smith and Parent, 1986; Nakano et al., 1990; Gimenez-Amaya et al., 1995; McFarland and Haber, 2000). Specific relay or association thalamic nuclei also project to the striatum, but to a lesser extent than intralaminar nuclei (Smith and Parent, 1986; McFarland and Haber, 2001). Recently, McFarland and Haber (2000) have reported convergent projections from various interconnected ventral thalamic motor relay nuclei and frontal cortical motor areas to broad territories of the postcommissural putamen, which provides further evidence for the specificity of thalamostriatal projections. The use of highly sensitive anterograde axonal tracers revealed that the thalamostriatal pathway arising from CM and PF is massive, topographically organized, and highly specific (Nakano et al., 1990; Sadikot et al., 1992a,b; Groenewegen and Berendse, 1994). In primates, where the CM and PF are well differentiated, the two nuclei largely innervate different functional striatal territories. The CM projects mainly to the post-commissural sensorimotor putamen, where fibers terminate in a band-like fashion, whereas the PF input preferentially innervates the limbic and associative striatal territories, where it terminates in a patchy-like manner (Smith and Parent, 1986; Sadikot et al., 1992a,b; Sidibé and Smith, 1996). Thalamic inputs to the ventral striatum also arise from midline and rostral intralaminar nuclei (Groenewegen and Berendse, 1994; Gimenez-Amaya et al., 1995). This functional segregation pattern is also maintained by cortical and subcortical projections to the CM/PF thalamic complex; sensorimotor afferents terminate principally

in CM, whereas visual, associative and limbic-related inputs invade the PF (Sadikot et al., 1992a). Thalamostriatal projections from both CM and PF terminate preferentially in the matrix compartment of the sensorimotor and limbic-associative territories of the striatum (Sadikot et al., 1992b; Sidibé and Smith, 1996).

## 2.2. Chemistry of Thalamostriatal Projections

Although it long remained controversial, excitatory amino acids are now considered as the main neurotransmitters used by thalamostriatal neurons. In rats, cortical and thalamic inputs mediate their excitatory effects on striatal acetylcholine release via different subtypes of ionotropic glutamate receptors. Cortical afferents activate AMPA receptors whereas thalamic inputs from PF tonically influence NMDA receptors (Consolo et al., 1996). Anatomical evidence from our laboratory show that group I metabotropic glutamatergic receptors are expressed at the edges of synapses established by CM terminals in the monkey putamen (Paquet and Smith, 2000). Furthermore, pre-synaptic mGLUR1a and kainate receptor subunits are found in thalamostriatal boutons (Paquet and Smith, 2000; Kieval et al., 2001). These observations indicate that NMDA, group I mGLURs and kainate receptors mediate and modulate thalamostriatal glutamatergic transmission in primates. In addition, various neuropeptides, including substance P, neuropeptide Y and somatostatin are found in thalamostriatal neurons (Sugimoto et al., 1985; Yasui et al., 1991). Furthermore, we recently showed that parvalbumin and calretinin are expressed in the perikarya and axon terminals of a subpopulation of thalamostriatal neurons in the monkey CM (Sidibé and Smith, 1999). On the other hand, CM and PF neurons are completely devoid of calbindin D 28K immunoreactivity (Jones and Hendry, 1989). Altogether, these observations indicate that the glutamatergic transmission at thalamostriatal synapses is under the control of various subtypes of glutamate receptors. The co-existence of neuropeptides and calcium binding proteins in CM terminals provides other mechanisms whereby the effects of glutamate at thalamostriatal synapses can be regulated.

## 2.3. Synaptic Organization of Thalamostriatal Projections

The medium sized spiny projection neurons and aspiny interneurons receive thalamic inputs in the rat and monkey striatum. In contrast to the glutamatergic inputs from the cortex that terminate almost exclusively on the heads of dendritic spines, thalamic afferents from CM/PF preferentially innervate dendritic trunks (Dube et al., 1988; Sadikot et al., 1992a; Smith et al., 1994). However, studies in rats suggest that striatal inputs from rostral intralaminar nuclei target preferentially dendritic spines (Xu and al., 1991), which indicate that the postsynaptic targets of thalamostriatal projections differ depending on their thalamic origin.

Another main difference between thalamic and cortical inputs to striatal neurons is their relationships with dopaminergic terminals. In contrast to cortical and dopaminergic inputs that often converge onto common postsynaptic targets, CM and dopaminergic terminals are never found in close proximity to each other on common postsynaptic elements in the monkey striatum (Smith et al., 1994). These data suggest that dopaminergic afferents are located to subservise a more specific modulation of afferent cortical inputs than afferent thalamic inputs from CM in the sensorimotor striatum (Smith et al., 1994). However, this does not rule out the possibility that dopamine and

thalamic inputs functionally interact to control neuronal activity in the striatum. For instance, there is evidence that NMDA-induced excitatory effects from PF modulate D1 dopamine receptor-mediated stimulation of acetylcholine release in the rat striatum (Consolo et al., 1996). Furthermore, the excitatory projection from PF exerts a facilitatory control over D1 receptor-induced C-fos expression in the striatum, probably via activation of NMDA receptors (Giorgi et al., 2001).

Thalamostriatal projections display a high degree of specificity at the synaptic level. Anatomical evidence from our laboratory demonstrated that terminals from CM preferentially innervate "direct" striatopallidal neurons projecting to the internal segment of the globus pallidus (GPI) in squirrel monkeys (Sidibé and Smith, 1996) (Fig. 1). Interestingly, Parthasarathy and Graybiel demonstrated that motor cortical inputs influence principally "indirect" striatofugal neurons in monkeys (Parthasarathy and Graybiel, 1997). These conclusions support the early data from Strick et al. (1995) who showed that "indirect" striatofugal neurons appeared to be the preferential target of motor corticostriatal projections in monkeys. These findings suggest that motor inputs from MI and CM are partly segregated at the level of individual striatofugal neurons in primates.

More recently, we reported that this high degree of synaptic specificity also characterizes CM projections to striatal interneurons showing that striatal interneurons immunoreactive for parvalbumin (PV), somatostatin (SS) and choline acetyltransferase (ChAT), but not those containing calretinin (CR), receive strong inputs from CM

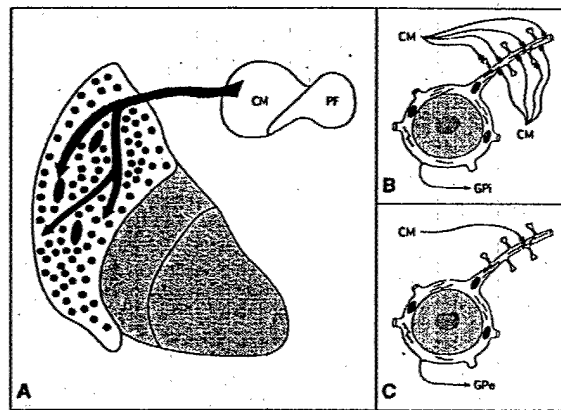

**Figure 1.** Differential synaptic innervation of direct and indirect striatofugal neurons in monkeys (see Sidibe and Smith, 1996 for details)

terminals in monkeys (Sidibé and Smith, 1999). It is noteworthy that ChAT-containing interneurons receive very sparse inputs from the cerebral cortex in rats and monkeys (Lapper and Bolam, 1992; Thomas et al., 2000). These data, therefore, indicate that cortical and thalamic terminals are segregated on the surface of individual cholinergic interneurons in such a way that thalamic afferents can exert a more powerful control than cortical inputs upon these interneurons. This hypothesis is supported by recent functional data demonstrating, on one hand, that facilitation of intrastriatal release of acetylcholine by cortical stimulation is short-lived and requires a much longer period of

activation than responses to stimulation of PF to reach a maximal effect (Baldi et al., 1995; Consolo et al., 1996). On the other hand, inputs from the CM/PF complex is required for the expression of behaviourally conditioned responses of cholinergic interneurons in monkey striatum (Aosaki et al., 1995; Matsumoto et al., 2001).

#### 2.4. Other Intralaminar Thalamic Efferents

In addition to the striatum, the CM innervates mostly motor and premotor cortices, whereas PF is principally related to prefrontal, premotor, cingulate and frontal eye field territories (Royce and Mourey, 1985; Darian-Smith et al., 1990; Barbas et al., 1991; Sadikot et al., 1992a). In contrast to the rostral intralaminar nuclei, where individual neurons project to both the cerebral cortex and the striatum, CM/PF neurons projecting to the striatum are largely segregated from those innervating the cerebral cortex in cats and monkeys (Royce, 1983; Macchi et al., 1984; Sadikot et al., 1992a).

In addition to the cortex and striatum, the CM/PF innervate the STN, the globus pallidus, the substantia nigra, the reticular nucleus of the thalamus, the zona incerta and

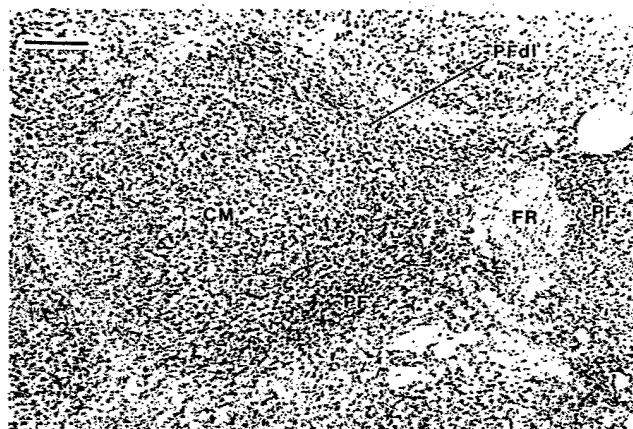

Figure 2. Nissl-stained section to show the different subdivisions of the CM/PF nuclear complex

the hypothalamus (Sadikot et al., 1992a). The thalamosubthalamic projection is functionally organized, so that sensorimotor neurons in CM terminate preferentially in the "motor-related" dorsolateral part of the STN whereas limbic and associative neurons in PF project almost exclusively to the medial "limbic-related" region of the STN (Sadikot et al., 1992a; Féger et al., 1997). In rats, the thalamosubthalamic input is excitatory and tonically drives the activity of STN neurons (Féger et al., 1997). Furthermore, Féger et al. (1994) demonstrated that thalamostriatal and thalamosubthalamic projections arise from largely segregated sets of PF neurons by means of double retrograde fluorescent labeling method in rats. In contrast, a recent single cell filling study showed that some PF neurons that project to the striatum send axon collaterals to the STN in rats. (Deschênes et al., 1996). Recent functional data, using cytochrome oxidase mRNA as a marker of metabolic activity, provided evidence that changes in STN activity in Parkinson's disease is not solely mediated by a reduction

of GPe inhibitory inputs but also by the hyperactivity of excitatory thalamostriatal neurons in the PF (Hirsch et al. 2000).

### 3. SYNAPTIC INPUTS TO THALAMOSTRIATAL NEURONS IN CM/PF

#### 3.1. Pallido- and Nigro-Intralaminar Projections

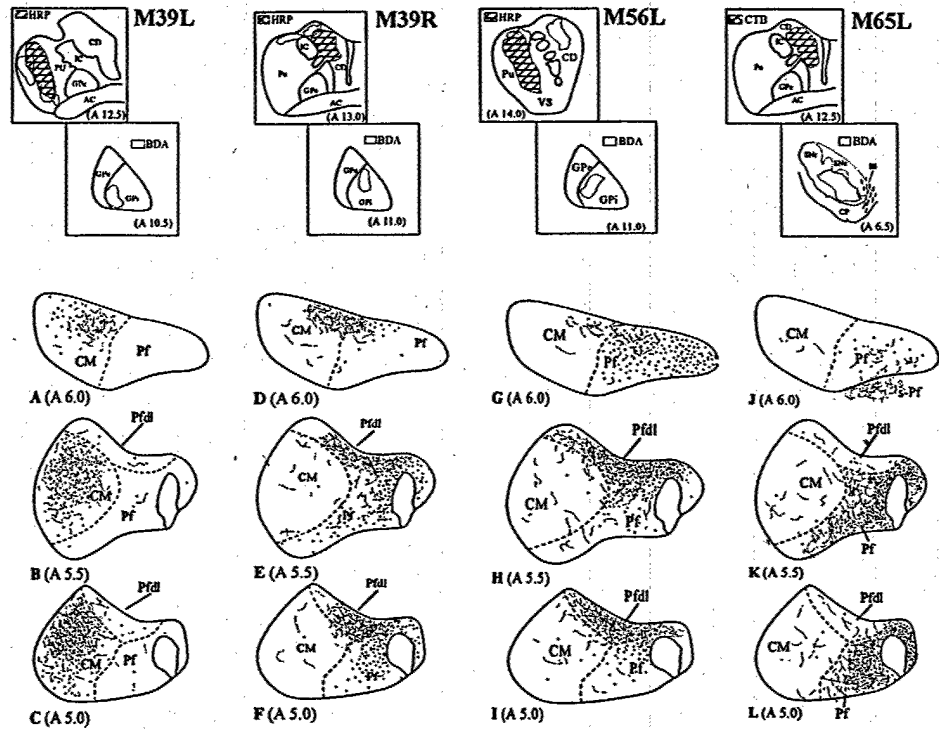

**Figure 3.** Schematic distribution of anterogradely labelled fibers and retrogradely labelled cells in CM/PF following combined injections of BDA in various functional territories of GPi and SNr with WGA-HRP or cholera toxin B in the striatum.

In addition to the ventral anterior/ventrolateral (VA/VL) nuclei, the CM/PF nuclear complex is another target of pallidal efferents in the thalamus of primates (Harnois and Filion, 1982; Parent et DeBellefeuille, 1983) and nonprimates (Harnois and Filion, 1982). The majority of GPi cells that project to the CM/PF send axon collaterals to the VL (Harnois and Filion, 1982; Parent and DeBellefeuille, 1983). In contrast to the ventral nuclear group which projects to the cerebral cortex, the major target of CM/PF efferents is the striatum (Smith and Parent, 1986; Sadikot et al., 1992a). Although both VA/VL and CM/PF receive, but also influence the basal ganglia, the pallido-thalamo-

cortical pathway through the VA/VL has been the subject of much more extensive anatomical and physiological studies (Strick, 1985; Rouiller et al., 1994; Inase and Tanji 1995; Sakai et al., 1996) than the pallido-thalamostriatal system. Earlier investigations of the source and distribution of pallidal inputs to the CM/PF nuclear complex, using retrograde tracer injections that involved the whole caudal intralaminar complex (Parent and DeBellefeuille, 1983; Fenelon et al., 1991), or anterograde tracer injections that covered large areas of GPi (DeVito and Anderson, 1982; Inase and Tanji, 1995; Sakai et al., 1996), indicated that CM was the sole intralaminar target of GPi efferents in monkeys (Parent and Hazrati, 1995; Percheron et al., 1996). However, none of those studies took into consideration the strict functional segregation imposed upon GPi and CM/PF by cortical and subcortical afferents. It is well established, based on anatomical and physiological studies that the GPi is segregated into sensorimotor, associative and limbic territories (Parent, 1990). We, therefore, re-examined the organization of the pallido-intralaminar projection in relation to the functional territories of the GPi in squirrel monkeys (Sidibe et al., 1997). These studies demonstrate that functionally segregated outputs from GPi largely innervate different regions of CM/PF. The sensorimotor GPi projects exclusively to the CM, whereas the associative and limbic GPi innervate the dorsolateral part of PF (PFdl) and the PF, respectively. The PFdl, which has never been considered as a separate entity before (Sadikot et al., 1992a; Parent and Hazrati, 1995; Percheron et al., 1996), is easily distinguishable from other parts of the CM/PF in Nissl-stained sections, by the shape and the mediolateral orientation of the neuronal somata (Fig. 2). These findings led us to elucidate in more details the relationships between functionally segregated pallidothalamic and thalamostriatal neurons in monkeys using anterograde and retrograde tracer injections in the GPi and the striatum. Results of these studies indicate that pallidal axons from the sensorimotor GPi terminate exclusively in CM where they form synapses with

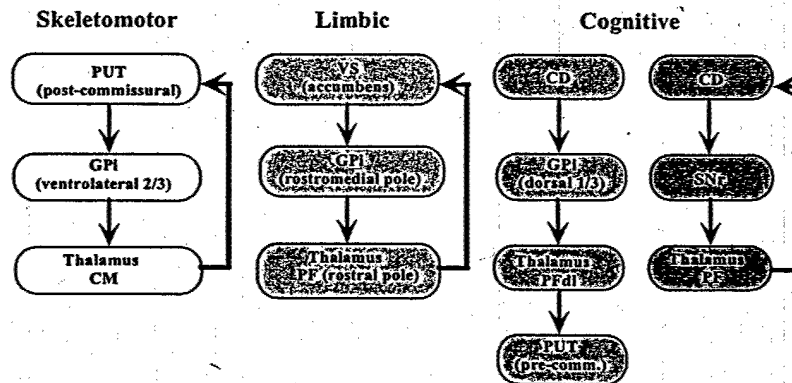

Figure 4. Proposed functional basal ganglia-thalamostriatal circuits through CM/Pf in primates.

thalamostriatal neurons projecting back to the sensorimotor territory of the striatum (Fig. 3A-C). In contrast, associative inputs from the caudate-receiving territory of GPI terminate massively in the PFdl, which does not project back to the caudate nucleus but rather innervates the pre-commissural part of the putamen (Fig. 3D-I). Finally, the limbic GPI innervates selectively the rostral third of PF that projects to the nucleus accumbens (Sadikot et al., 1992a; Gimenez-Amaya et al., 1995). Therefore, it appears that the CM/PF complex is part of closed and open functional loops with the striatopallidal complex in primates (Fig. 4).

In addition to the GPI, the SNr also projects to rostral and caudal intralaminar thalamic nuclei. Although a SNr-PF projection is well established in rodents, data in monkeys regarding such a pathway are limited and controversial (Ilinsky et al., 1985). We recently investigated the organization and synaptic connectivity of this projection in squirrel monkeys using sensitive anterograde transport methods. Our findings demonstrate that the SNr projection to the caudal intralaminar nuclei is confined to PF where it terminates preferentially on distal dendrites of thalamostriatal neurons projecting to the caudate nucleus (Fig. 3J-L). This provides an additional associative circuit between basal ganglia and thalamostriatal neurons in primates (Fig. 4).

### 3.2. Ascending Pedunclopontine Inputs to CM/PF

In addition to its connections with the basal ganglia, there is evidence that CM/PF receive substantial brainstem inputs from regions involved in the control of sleep-wake cycle. One of the well established sources of synaptic inputs to the intralaminar nuclei is the tegmental pedunclopontine nucleus (PPN). In fact, the PPN sends dense cholinergic and non-cholinergic projections to various thalamic nuclei, and play a major role in modulating the level of activity of thalamocortical neurons, thereby influence the state of cortical desynchronization and awareness (Ingliss and Winn, 1995; Reiner, 1995; Steriade, 1995). The exact cellular origin of the cholinergic innervation of different groups of thalamic nuclei has been the subject of many studies in rats and cats but received much less attention in primates (Wainer and Mesulam, 1990). In order to better understand the mechanism by which PPN afferents might be involved in controlling activity of thalamostriatal neurons in primates, we recently undertook an electron microscopic study of the chemoanatomical organization and synaptic connectivity of PPN projection to the caudal intralaminar nuclei in monkeys using anterograde labeling technique combined with postembedding immunocytochemistry localization for GABA and glutamate. Findings of this study demonstrate: (1) PPN input is largely confined to PF and PFdl (Fig. 5A), (2) PPN projections to the CM/PF is highly heterogeneous containing acetylcholine, glutamate, GABA and co-localized glutamate or GABA with acetylcholine (Fig. 5B-C), (3) PPN terminals form symmetric and asymmetric synapses with dendrites of thalamostriatal PF neurons projecting to the caudate nucleus (Fig. 5B-C). These observations raise the interesting possibility that attention-related inputs from PPN are mainly transmitted to associative and limbic thalamostriatal neurons but much less to sensorimotor neurons in CM.

### 3.3. Others Afferents to CM/PF

The CM/PF receives many other afferent projections which, due to space limitation, will not be discussed in details in the present review. These include brainstem inputs from the superior colliculus, ventral tegmental area, periaqueductal gray, dorsal raphe,

locus coeruleus, reticular formation, parabrachial nucleus, principal trigeminal nucleus, deep cerebellar nuclei and spinal cord (Royce et al., 1991; Sadikot et al., 1992a). Additional forebrain inputs arise from the amygdala, hypothalamus, zona incerta and reticular thalamic nucleus (Royce et al., 1991; Sadikot et al., 1992a).

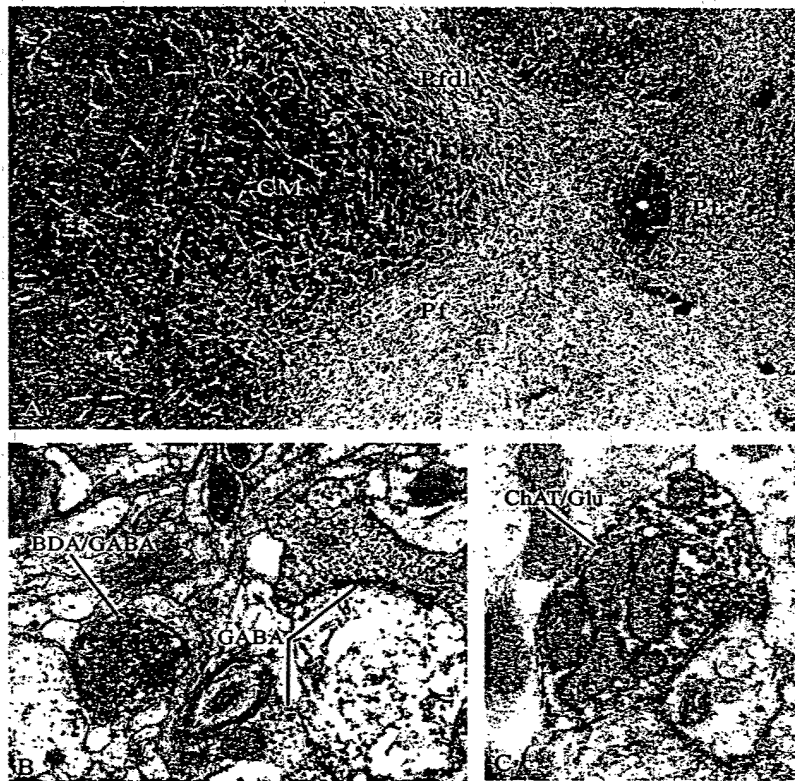

Figure 5. (A) Anterograde labelling in Pf and Pfdl after BDA injections in PPN. (B) A BDA-containing bouton that expresses GABA immunoreactivity in Pf. Other GABA-positive terminals are shown. (C) An axon terminal that co-expresses choline acetyltransferase (ChAT) and glutamate in Pf.

#### 4. CONCLUSIONS

Data presented in this study emphasize the high degree of functional specificity of the basal ganglia thalamostriatal system in mammals. Although the exact role of the thalamostriatal projections in the functional circuitry of basal ganglia is still unclear, the importance of this system in providing attention-specific sensory information to striatal neurons should definitely be considered. Furthermore, recent evidence showing that neurons in CM/Pf degenerate in Parkinson's disease strengthen the functional links between these thalamic nuclei and basal ganglia (Henderson et al., 2000). Additional roles of CM/Pf in controlling sleep-wake cycle, pain tolerance and saccadic eye

movements also deserve consideration while examining the functions of these nuclei in the CNS (Jones, 1985).

## 5. ACKNOWLEDGMENTS

This work was supported by NIH grants R01 NS37948 and RR00165 and a grant from the US Army

## 6. REFERENCES

- Aosaki, T. et al., 1995, Temporal and spatial characteristics of tonically active neurons of the primate's striatum. *J. Neurophysiol.* 73: 1234-1252.
- Baldi, G., et al., 1995, Trans-synaptic modulation of striatal ACh release in vivo by the parafascicular thalamic nucleus. *Eur. J. Neurosci.* 7: 1117-1120.
- Barbas, H. et al., 1991, Diverse thalamic projections to the prefrontal cortex in the rhesus monkey. *J. Comp. Neurol.* 313: 65-94.
- Calabresi, P., De Murtas, M., and Bernardi, G., 1997, The neostriatum beyond the motor function: experimental and clinical evidence. *Neuroscience* 78:39-60.
- Consolo, S. et al., 1996, The cerebral cortex and parafascicular thalamic nucleus facilitate in vivo acetylcholine release in the rat striatum through distinct glutamate receptor subtypes. *J. Comp. Neurol.* 397:403-420.
- Darian-Smith, C., Darian-Smith, I., and Cheema, S., 1990, Thalamic projections to sensorimotor cortex in the macaque monkey: Use of multiple retrograde fluorescent tracers. *J. Comp. Neurol.* 299:17-46.
- DeLong, M.R., 1990, Primate models of movement disorders of basal ganglia origin. *Trends Neurosci.* 13:281-285.
- Deschenes, M. et al., 1996, A single-cell study of the axonal projections arising from the posterior intralaminar thalamic nuclei in the rat. *Eur. J. Neurosci.* 8:329-343.
- DeVito, J.L., and Anderson, M.E., 1982, An autoradiographic study of efferent connections of the globus pallidus in *Macaca mulatta*. *Exp. Brain Res.* 46: 107-117.
- Dube, L., Smith, A.D. and Bolam, J.P., 1988, Identification of synaptic terminals of thalamic and cortical origin in contact with distinct medium-sized spiny neurons in the rat neostriatum. *J. Comp. Neurol.* 267: 455-471.
- Feger, J., Bevan, M., and Crossman A. R., 1994, The projections from the parafascicular thalamic nucleus to the subthalamic nucleus and the striatum arise from separate neuronal populations—a comparison with the corticostriatal and corticosubthalamic efferents in a retrograde fluorescent double-labelling study. *Neuroscience* 60: 125-132.
- Feger et al., 1997, Updating the functional model of the basal ganglia. *Trends Neurosci.* 20: 152-153.
- Fenelon, G., Francois, C., Percheron, G., and Yelnik, J., 1991, Topographic distribution of pallidal neurons projecting to the thalamus in macaques. *Brain Res.* 520: 27-35.
- Gerfen, C.R., and Wilson C.J., 1996, The Basal Ganglia. In *Handbook of Chemical Neuroanatomy, Integrated systems of the CNS, Part III*, A. Bjorklund, T. Hokfelt, and L. Swanson eds, Elsevier, Amsterdam, pp.369-466.
- Gimenez-Amaya, J.M., McFarland, N.R., De Las Heras, S., and Haber, S.N., 1995, Organization of thalamic projections to the ventral striatum in the primate. *J. Comp. Neurol.* 354: 127-149.
- Giorgi, S., Rimoldi, M., and Consolo, S., 2001, Parafascicular thalamic nucleus deafferentation reduces c-fos expression induced by dopamine D-1 receptor stimulation in rat striatum. *Neuroscience* 103: 653-661.
- Groenewegen H. J., and Berendse, H.W., 1994, The specificity of the nonspecific midline and intralaminar thalamic nuclei. *Trends Neurosci.* 17:52-57.
- Harnois, C., and Filion, M., 1982, Pallidofugal projections to thalamus and midbrain: A quantitative antidromic activation study in monkeys and cats. *Exp. Brain Res.* 47:277-285.
- Henderson, J.M., Carpenter, K., Cartwright, H., and Halliday, G.M., 2000, Loss of thalamic intralaminar nuclei in progressive supranuclear palsy and Parkinson's disease: clinical and therapeutic implications. *Brain* 123: 1410-1421.
- Hirsch, E. et al., 2000, Metabolic effects of nigrostriatal denervation in basal ganglia. *Trends in Neurosci.* 23: S78-S85.
- Ilinsky, I.A., Jouandet, M.L. and Goldman-Rakic, P.S., 1985, Organization of the nigrothalamocortical system in the rhesus monkey. *J. Comp. Neurol.* 236: 315-330.
- Inase, M., and Tanji, J., 1995, Thalamic distribution of projection neurons to the primary motor cortex relative to afferent terminal fields from the globus pallidus in macaque monkey. *J. Comp. Neurol.* 353:415-426.
- Inglis, W.L., and Winn, P., 1995, The pedunculopontine tegmental nucleus: where the striatum meets the reticular formation. *Prog. Neurobiol.* 47: 1-29.
- Jones, E.G., 1985, *The Thalamus*. Plenum Press, New York.
- Jones, E.G., and Hendry, S.H.C., 1989, Differential calcium-binding protein immunoreactivity distinguishes classes of relay neurons in monkey thalamic nuclei. *Eur. J. Neurosci.* 1: 222-247.
- Kieval, J.Z. et al., 2001, Subcellular and subsynaptic localization of pre- and post-synaptic kainate receptor subunits in the monkey striatum. *J. Neurosci* (in press).
- Lapper, S.R., and Bolam, J.P., 1992, Input from the frontal cortex and the parafascicular nucleus to cholinergic interneurons in the dorsal striatum of the rat. *Neuroscience* 51: 533-545.

- Macchi, G. et al., 1984, The thalamo-caudate versus thalamo-cortical projections as studied in the cat with fluorescent retrograde double labeling. *Exp. Brain Res.* 54: 225-239.
- Matsumoto, N., Minamimoto, T., Graybiel, A.M., and Kimura, M., 2001, Neurons in the thalamic CM-PF complex supply striatal neurons with information about behaviorally significant sensory events. *J. Neurophysiol.* 85: 960-976.
- McFarland, N.R., and Harber, S.N., 2000, Convergent inputs from thalamic motor nuclei and frontal cortical areas to the dorsal striatum in the primate. *J. Neurosci.* 20: 3798-3813.
- McFarland, N.R., and Harber, S.N., 2001, Organization of thalamostriatal terminals from the ventral motor nuclei in the macaque. *J. Comp. Neurol.* 429:321-336.
- Nakano, K., Hasegawa, Y., Tokushige, T., Nakagawa, S., and Mizuno, N., 1990, Topographical projections from the thalamus, the subthalamic nucleus and pedunculopontine tegmental nucleus to the striatum in the Japanese monkey *Macaca mulatta*. *Brain Res.* 537:54-68.
- Parent, A., and DeBellefeuille, 1983, The pallidointralaminar and pallidonigral projections in primate as studied by retrograde double-labeling method. *Brain Res.*, 278: 11-27.
- Paquet, M., and Smith, Y., 2000, Subsynaptic localization of group I metabotropic receptors at glutamatergic synapses in monkey striatum. *Soc. Neurosci. Abstr.* 26: 379.
- Parent, A., 1990, Extrinsic connections of the basal ganglia. *Trends Neurosci.* 13: 254-258.
- Parent, A., and Hazrati, L.N., 1995, Functional anatomy of the basal ganglia. I. The cortico-basal-thalamo-cortical loop. *Brain Res. Rev.* 20: 91-127.
- Parthasarathy, H.B., and Graybiel, A.M., 1997, Cortically driven immediate-early gene expression reflects modular influence on sensorimotor cortex on identified striatal neurons in the squirrel monkey. *J. Neurosci.* 17: 2477-2491.
- Percheron, G. et al., 1996, The primate motor thalamus. *Brain Res. Rev.* 22: 93-181.
- Powell, T.P.S., and Cowan, W.M., 1956, A study of thalamo-striate relations in the monkey. *Brain* 79:364-390.
- Reiner, P.B., 1995, Are mesopontine cholinergic neurons either necessary or sufficient components of the ascending reticular activating system? *Sem. Neurosci.* 7: 355-359.
- Rouiller, E.M., Liang, F., Babalian, A., Moret, V., and Wiesendanger, M., 1994, Cerebellothalamocortical and pallidothalamocortical projections to the primary and supplementary motor cortical areas: A multiple tracing study in macaque monkeys. *J. Comp. Neurol.* 345:185-213.
- Royce, G. J., 1983, Single thalamic neurons which project to both the rostral cortex and caudate nucleus studied with the fluorescent double labeling method. *Exp. Neurol.* 79: 773-784.
- Royce, G.J., and Mourey, R.J., 1985, Efferent connections of the centromedian and parafascicular thalamic nuclei: An autoradiographic investigation in the cat. *J. Comp. Neurol.* 235: 277-300.
- Royce, G.J., Bromley, S., and Gracco, C., 1991, Subcortical projections to the centromedian and parafascicular thalamic nuclei in the cat. *J. Comp. Neurol.* 306: 129-155.
- Sadikot, A.F., Parent, A., and Francois, C., 1992a, Efferent connections of the centromedian and parafascicular thalamic nuclei in the squirrel monkey: A PHA-L study of subcortical projections. *J. Comp. Neurol.* 315: 137-159.
- Sadikot, A.F., Parent, A., Smith, Y., and Bolam, J.P., 1992b, Efferent connections of the centromedian and parafascicular thalamic nuclei in the squirrel monkey: a light and electron microscopic study of the thalamostriatal projection in relation to striatal heterogeneity. *J. Comp. Neurol.* 320: 228-242.
- Sakai, S. T., Inase, M., and Tanji, J., 1996, Comparison of cerebellothalamic and pallidothalamic projection in the monkey (*Macaca fuscata*): A double anterograde labeling study. *J. Comp. Neurol.* 368: 215-228.
- Sidibe, M., Bevan, M.D., Bolam, J.P., and Smith, Y., 1997, Efferent connections of the internal segment of the globus pallidus in the squirrel monkey. I. Topography and synaptic organization of the pallidothalamic projection. *J. Comp. Neurol.* 382: 323-347.
- Sidibe, M., and Smith, Y., 1999, Thalamic inputs to striatal interneurons in monkeys: Synaptic organization and co-localization of calcium binding proteins. *Neuroscience* 89: 1189-1209.
- Sidibe, M., and Smith, Y., 1996, Differential synaptic innervation of striatofugal neurons projecting to the internal or the external segments of the globus pallidus by thalamic afferents in the squirrel monkey. *J. Comp. Neurol.* 365: 445-465.
- Smith, Y., Bennett, B.D., Parent, A., and Sadikot, A.F., 1994, Synaptic relationships between dopaminergic afferents and cortical or thalamic input at the single cell level in the sensorimotor territory of the striatum in monkey. *J. Comp. Neurol.* 344: 1-19.
- Smith, Y., and Parent A., 1986, Differential connections of caudate nucleus and putamen in the squirrel monkey (*Saimiri sciureus*). *Neuroscience* 18: 347-371.
- Steriade, M., 1995, Neuromodulatory systems of thalamus and neocortex. *Sem. Neurosci.* 7: 361-370.
- Strick, P.L., 1985, How do the basal ganglia and cerebellum gain access to the cortical motor areas? *Behav. Brain Res.* 18: 107-123.
- Strick, P.L., Dum, R.P., and Picard, N., 1995, Macro-organization of the circuits connecting the basal ganglia with the cortical motor areas. In *Models of information processing in the basal ganglia*. J.C. Houk, J.L. Davis, and D.G. Beiser eds. MIT Press, Cambridge, pp. 117-130.
- Sugimoto, T., Itoh, K., Yasui, Y., Kaneko, T., and Mizuno, N., 1985, Coexistence of neuropeptides in projection neurons of the thalamus in the cat. *Brain Res.* 347: 381-384.
- Thomas, T.M., Smith, Y., Levey, A.I., and Hersch, S.M., 2000, Cortical inputs to m2-immunoreactive striatal interneurons in rat and monkey. *Synapse* 37:252-261.
- Vogt, C., and Vogt, O., 1941, Thalamusstudien I-III. I. Zur Einföhrung, II. Homogenität und Grenzgestaltung der Grisea des Thalamus, III. Griseum centrale (centrum medianum Luys). *J. Physiol. Neurol. Lpz.* 50:31-154.
- Wainer, B.H., and M.-M. Mesulam, 1990, Ascending cholinergic pathways in the rat brain. In *Brain Cholinergic Systems*, M. Steriade and D. Biesold eds, Oxford University Press, Oxford, pp. 65-119.

- Xu, Z.C., Wilson, C.J., and Emson, P.C., 1991, Restoration of thalamostriatal projections in rat neostriatal grafts: an electron microscopic analysis. *J. Comp. Neurol.* 303: 22-35.
- Yasui, Y., Saper, C.B., and Cachetto, D.T., 1991, Calcitonin gene-related peptide immunoreactive projections from the thalamus to the striatum and amygdala in the rat. *J.Comp.Neurol.* 227: 200-213.

# ANATOMY AND SYNAPTIC CONNECTIVITY OF THE BASAL GANGLIA

SMITH, Yoland  
DAMD17-99-1-9546  
APPENDIX 4

SMITH, Yoland, PhD and CHARARA, Ali, PhD

Yerkes Regional Primate Research Center and Department of Neurology, Emory University,  
Atlanta, GA 30329, USA.

Send Correspondence to:

Yoland Smith, PhD  
Yerkes Primate Center  
Emory University  
954, Gatewood Rd NE  
Atlanta, GA 30329  
USA

TEL: (404) 727 7519  
FAX: (404) 727 3278  
EMAIL: [yolands@rmy.emory.edu](mailto:yolands@rmy.emory.edu)

PS The mailing address of Ali Charara is the same as above.

## Overall Organization of Basal Ganglia

The basal ganglia are a group of sub-cortical nuclei of the mammalian brain that are intimately involved in motor control but also play complex roles in mediating cognitive and limbic functions. The basal ganglia traditionally include the striatum that comprises the caudate nucleus (CD), the putamen (PU) and the nucleus accumbens (Acc), the external globus pallidus (GPe; globus pallidus in non-primates), the internal globus pallidus (GPi; entopeduncular nucleus in non-primates), the substantia nigra (SN) which includes the dopaminergic neurons in the pars compacta (SNc) and the GABAergic neurons in the pars reticulata (SNr), and the subthalamic nucleus (STN). They are a complex and highly interconnected group of nuclei that have been the subject of intensive studies over many decades because of their clear involvement in neurological disorders that manifest themselves in abnormal motor activities. The striatum, and to a lesser extent the STN (see below), are the main entrances of extrinsic information to the basal ganglia circuitry. The striatal architecture is divided into two compartments termed "patches (or striosomes)" and "matrix" which are characterized by differential expression of various neurotransmitters, receptors and input-output connections<sup>1</sup>. The cerebral cortex and the intralaminar thalamic nuclei are the two major sources of excitatory glutamatergic afferents to the striatum and STN. Dopaminergic inputs from the SNc and the ventral tegmental area (VTA) as well as serotonin inputs from the dorsal raphe tightly interact with glutamatergic afferents to modulate striatal neuronal activity. Once integrated at the striatal level, the information is conveyed by medium-sized spiny projection neurons to the basal ganglia output nuclei namely, the GPi and SNr which, in turn, forward basal ganglia outflow to, either, frontal areas of the cerebral cortex via the ventrolateral thalamus or various brainstem structures (superior colliculus, lateral habenular nucleus, pedunculopontine nucleus, parvicellular reticular formation).

Furthermore, part of the information flowing through the GPi returns to the striatum via connections with thalamostriatal neurons in the caudal intralaminar nuclei (Fig. 1).

In the following account, we will review some aspects of the chemical anatomy and synaptic connectivity of the basal ganglia. Because of space limitations, we do not intend to review every aspects of the basal ganglia circuitry. We will rather highlight some recent findings that have introduced novel concepts of basal ganglia organization. For a detailed account of earlier literature, the reader is referred to extensive reviews published over the past ten years

1,2,3,4,5,6,7,8,9,10,11,12,13

### **Functional Organization of the Corticostriatal Projection**

The entire cortical mantle provides a highly topographic inputs to the striatum. In primates, the somatosensory, motor and pre-motor cortices project somatotopically to the post-commissural region of the putamen, the associative cortical areas project to the caudate nucleus and the pre-commissural putamen whereas the limbic cortices, the amygdala and the hippocampus terminate preferentially in the ventral striatum, which includes the nucleus accumbens and the olfactory tubercle<sup>6,7,10,12,13</sup>.

Processing and integration of functionally-related information within these striatal territories is likely to be very complex and governed by both convergence and segregation of cortical inputs. For instance, projections from prefrontal oculomotor areas interconnected by cortico-cortical projections, namely the frontal eye field and the supplementary eye field, tightly overlap within the monkey striatum<sup>14</sup>. On the other hand, Selemon and Goldman-Rakic demonstrated that projections from connectionally linked associative cortical areas in the frontal, parietal and temporal lobes are, either, completely segregated or interdigitated within a zone of overlap in the monkey striatum. The results of this study also introduced a novel concept of organization of corticostriatal projection according to which associative cortices project to longitudinally extensive domains that are aligned along the mediolateral axis of the caudate

nucleus in primates<sup>15</sup>. Complex patterns of intrastriatal organization were also found for projections from sensorimotor cortical areas<sup>16,17</sup>. For example, regions representing homologous body parts in different somatosensory cortical regions (SI) and primary motor cortex (MI) send projections that converge within the ipsilateral putamen whereas contralateral projections from MI, except those from the face area, interdigitate with ipsilateral MI/SI projection sites in squirrel monkeys<sup>17</sup>.

The striatum is composed of two main populations of neurons; the medium-sized GABAergic projection neurons, which have their dendrites densely covered with spines and account for more than 90% of the total neuronal population of the striatum and the aspiny neurons which are much less abundant and generally considered as interneurons<sup>3,7,10,18</sup>. Dendritic spines of projection neurons are, by far, the main targets of corticostriatal afferents. Convergence of cortical and dopamine inputs at the level of individual spines was found to be a major feature of the synaptic connectivity of striatofugal neurons in rats and monkeys<sup>3,12,13</sup>. GABAergic interneurons also receive significant cortical inputs<sup>19</sup> whereas cholinergic interneurons are almost completely devoid of cortical afferents except for sparse inputs on their distal dendrites<sup>20,21</sup>. The projection neurons have extensive overlapping dendritic trees and emit axon collaterals that form symmetric synapses with dendrites and spines of neighboring neurons in the striatum<sup>3,7</sup>. Although these intrastriatal connections have long been considered as the main substrate for the mutual GABAergic inhibition between striatofugal neurons, electrophysiological studies showed that the inhibition among spiny neurons is, rather, weak and unlikely to mediate the strong feedback inhibitory post synaptic potentials (IPSPs) recorded in striatal neurons following stimulation of cortical afferents<sup>23</sup>. The feedforward pathway through GABAergic interneurons is probably a better candidate for generating these inhibitory influences<sup>7,8,18,24</sup>.

Three types of cortical neurons project to the striatum in rats<sup>7,10</sup>. The most common type includes large cortical neurons located in deep layer V. These cells have extensive intracortical axon arborizations and emit fine collaterals, with only few terminals, in the ipsilateral striatum

which indicates that these cortical neurons innervate a restricted population of striatal cells according to a strict topographical organization. The less common type of pyramidal tract cells that contribute to the corticostriatal projection are medium-sized and located in superficial layer V. These neurons have a limited intracortical arborization but terminate profusely in the ipsilateral striatum. A third type of corticostriatal neuron is located in superficial layer V and deep part of layer III. These neurons give rise to an extensive axonal arbor in the region of the parent perikaryon and form diffuse plexuses of axon terminals that occupy a large volume of the ipsilateral and contralateral striata. The region of the striatum innervated by these axons can be as large as 1 mm across, but within these regions the density of axonal arborization is very sparse, leaving large areas uninnervated. This pattern of arborization implies that individual cortical fibres cross the dendritic fields of many striatal neurons but form few synapses with any given cell<sup>8,10</sup>. Conversely, striatal neurons can be expected to receive inputs from a large number of cortical fibres, but not to receive many synapses from any one of them. The functional implications of such a pattern of organization are twofolds: (1) it suggests that striatal neurons may increase their firing rate only if there is activation of convergent input from many different cortical neurons and (2) that nearby striatal neurons with totally overlapping dendritic volumes have few presynaptic cortical axons in common<sup>8,10</sup>. These anatomical findings strongly support a high degree of specificity of the corticostriatal projection and explain the absence of redundancy in responses of neurons near each other in the striatum<sup>7,8</sup>.

### **Functional Organization of the Thalamostriatal Projection**

In addition to the cerebral cortex, the intralaminar thalamic nuclei are a major source of excitatory afferents to the striatum. However, the influence of thalamic inputs on the activity of striatal neurons has received much less attention than corticostriatal projections. Anterograde tracing studies in rats and monkeys indicate that the thalamostriatal projection is massive, topographically organized and highly specific<sup>6,13,25</sup>. In primates, the caudal intralaminar nuclear

group, namely the centromedian (CM) and parafascicular (PF) nuclei provide massive inputs that largely terminate in different functional territories in the striatum<sup>6,26,27</sup>. Both CM and PF inputs terminate preferentially in the matrix compartment of the dorsal and ventral striatum<sup>26</sup>. The CM projects massively to the post-commissural sensorimotor part of the putamen whereas the PF innervates predominantly the caudate nucleus and, to a lesser extent, the ventral striatum<sup>26,27</sup>. The striatal input from PF terminates in a patch-like manner that invades preferentially the matrix compartment in the caudate nucleus and the nucleus accumbens. On the other hand, the pre-commissural putamen receives inputs from the so-called dorsolateral PF (PFdl), a group of fusiform neurons that extend mediolaterally along the dorsal border of CM<sup>28</sup>. In rats, thalamic inputs to the ventral striatum arise predominantly from midline and rostral intralaminar nuclei<sup>25</sup>. Specific relay nuclei also project to the striatum, but to a much lower extent than intralaminar nuclei<sup>6,13</sup>. As is the case for the motor and somatosensory cortical afferents, the CM input terminates in a band-like fashion<sup>26,27</sup>. Whether or not the thalamostriatal projection is somatotopic and overlaps with corticostriatal afferents remains to be established.

The medium spiny neurons are the main targets of thalamic afferents but, in contrast to cortical terminals which mostly terminate on the head of dendritic spines<sup>3</sup>, CM and PF inputs innervate preferentially the dendritic shafts of striatal neurons<sup>13,26,27,29</sup>. However, afferents from rostral intralaminar nuclei terminate almost exclusively on dendritic spines in rats<sup>30</sup>. In contrast to cortical and dopaminergic inputs which often converge on common postsynaptic targets, CM and dopaminergic terminals largely innervate different striatal elements<sup>31</sup>, which suggest that dopaminergic afferents are located to subserve a more specific modulation of afferent cortical input than afferent thalamic input in the striatum. Striatal interneurons immunoreactive for choline acetyltransferase, parvalbumin and somatostatin, but not those containing calretinin, receive inputs from CM in monkeys<sup>32,33</sup>. CM inputs also display a high degree of specificity in their pattern of synaptic innervation of striatal projection neurons (see below).

Altogether, these anatomical findings indicate that the thalamostriatal projections are more massive and much better organized than previously thought<sup>6,13,25</sup>. A major task over the

next few years will be to elucidate the sources and better characterize the type of information transmitted by the different populations of thalamostriatal neurons. This will help to better understand the mechanisms by which thalamic and cortical inputs interact to control the activity of striatofugal neurons.

It is noteworthy that some thalamic relay nuclei also project to the striatum in a highly specific and organized fashion<sup>34</sup>. Recent data demonstrated the convergence of interconnected cortical and ventral thalamic areas to specific regions of the sensorimotor striatum in monkeys<sup>35</sup>.

### GABA and Glutamate Receptors in the Striatum

Although glutamate is the transmitter of cortical and thalamic afferents, highly specific actions on particular postsynaptic targets may be achieved through the presence of different types of glutamate receptors. Glutamate receptors are classified in two categories of glutamate receptors: the ionotropic receptors which mediate fast and short lasting excitatory effects, and the metabotropic receptors which mediate slow and long-lasting modulatory effects of glutamatergic transmission. Ionotropic glutamate receptors include *N*-methyl-*D*-aspartate (NMDA; NR1, NR2A-D),  $\alpha$ -amino-3-hydroxy-5-methyl-4-isoxazolepropionate (AMPA; GluR1-GluR4) and kainate (GluR5-GluR7, KA1, KA2) subtypes. Metabotropic receptors include eight subtypes pooled into three major groups: group I (mGluR1 and mGluR5), group II (mGluR2, mGluR3), and group III (mGluR4, mGluR6, mGluR7, mGluR8). The results of recent studies indicate that various pre- and post-synaptic ionotropic and metabotropic glutamate receptors are involved in mediating and modulating excitatory effects in the striatum (Fig.2). In fact, striatal projection neurons and interneurons express several NMDA, AMPA and kainate receptor subunits<sup>36,37,38,39,40</sup>. Both AMPA and NMDA receptor subunits are found exclusively post-synaptically in the core of asymmetric axo-dendritic and axo-spinous synapses in the rat striatum<sup>38,41</sup>. Moreover, studies in the monkey striatum revealed that kainate receptors are found not only post-synaptically but also pre-synaptically in cortical-like terminals making asymmetric synapses

<sup>42</sup>. In addition to ionotropic receptors, striatal neurons are enriched in metabotropic glutamate receptors. The group I and some of the group III (mGluR4 and mGluR7) metabotropic glutamate receptors are expressed at a moderate to high level by most of striatal neurons <sup>43,44</sup>. Whereas strong immunoreactivity for group III mGluRs is found in glutamatergic corticostriatal terminals <sup>45,46</sup>, group I mGluRs are found postsynaptically: peri-synaptic to asymmetric axo-spinous synapses, in the core of GABAergic synapses, and peri-synaptic to dopaminergic synapses <sup>47,48</sup>. On the other hand, mGluR2 is confined to striatal cholinergic interneurons whereas mGluR3 is mostly expressed by glial cells <sup>43,49,50</sup>. Furthermore, a large population of corticostriatal terminals display mGluR2/3 immunoreactivity <sup>47,51</sup>. These observations indicate that corticostriatal terminals are associated with both pre and postsynaptic glutamate receptors (Fig. 2).

In addition to glutamatergic afferents, the striatum receives GABA-containing inputs from GABAergic interneurons, local collateral axons of medium-sized projection neurons as well as from GPe cells (see above). The inhibitory actions of GABA are mediated through two major groups of receptors: the ionotropic GABA-A receptors which are involved in fast synaptic inhibition and include 14 subunits ( $\alpha$ 1- $\alpha$ 6,  $\beta$ 1- $\beta$ 3,  $\gamma$ 1- $\gamma$ 3,  $\delta$ ,  $\epsilon$ ) <sup>52,53</sup>, and the metabotropic GABA-B receptors which mediate slow and long-lasting inhibition and include GABA-BR1 and GABA-BR2 subunits <sup>54,55,56</sup>. As expected, striatal neurons are enriched in both GABA-A and GABA-B receptors <sup>53,56,57,58,59,60</sup>. Whereas GABA-B receptors are homogeneously distributed and found in both medium-sized projection neurons and interneurons <sup>59</sup>, the GABA-A receptor subunits display different patterns of distribution: the  $\beta$ 2/3 subunits are confined to cholinergic neurons whereas the  $\alpha$ 1 subunit is abundant in the matrix compartment where it is expressed in medium spiny neurons <sup>58</sup>. GABA-A receptors are localized exclusively postsynaptically in the main bodies of symmetric synapses <sup>60,61</sup> whereas GABA-B receptors are found both postsynaptically in the main body of many symmetric synapses and presynaptically in terminals making asymmetric synapses <sup>48,59</sup> (Fig. 2). A small population of axons forming of "en passant" type symmetric synapses also express GABA-B receptors <sup>59</sup>. These data suggest that GABA can act either postsynaptically via GABA-A and GABA-B receptors to modulate GABAergic transmission,

and presynaptically via GABA-B receptors to modulate the activity of glutamatergic afferents in the striatum.

### Other Afferents to the Striatum

The striatum is the target of many other afferents which, due to space limitation, will not be discussed in detail in the present review. These include the massive projection from midbrain dopaminergic neurons in the substantia nigra pars compacta, ventral tegmental area and retrorubral area<sup>61a,61b</sup> as well a subthalamostriatal projection. In monkeys, subthalamic neurons that project to the caudate nucleus and putamen arise from two distinct neuronal populations; those that innervate the putamen are located in the sensorimotor-related dorsolateral two thirds of the STN whereas subthalamo-caudate neurons are found ventromedially in the associative territory<sup>34,62</sup>. Other minor inputs to the striatum arise from the tuberomammillary nucleus<sup>63</sup> the brainstem pedunculopontine nucleus<sup>34,64</sup>, the locus coeruleus<sup>34</sup>, the spinal nucleus of the trigeminal nerve<sup>65</sup>, the peripeduncular nucleus<sup>66</sup> and the substantia innominata<sup>67</sup>.

### The Direct and Indirect Striatofugal Projections

The cortical inputs together with the many other intrinsic and extrinsic afferents are integrated by medium sized projection neurons in the striatum. Once processed at the striatal level, the cortical information is conveyed to the output nuclei of the basal ganglia (GPi and SNr) via two routes, the so-called *direct* and *indirect* striatofugal pathways<sup>10,68,69,70</sup>. The direct pathway arises from a sub-population of spiny neurons that project directly to the GPi/SNr whereas the indirect pathway arises from a separate population of spiny neurons that project to the GPe. In turn, the GPe conveys the information to the STN which relays it to the output nuclei of the basal ganglia. The sub-populations of striatal output neurons that give rise to the direct and indirect pathways are further distinguished by their expression of neuropeptides and dopamine

receptor sub-types. Thus, although all striatal spiny neurons use  $\gamma$ -aminobutyric acid (GABA) as their main transmitter, the sub-population that gives rise to the direct pathway is characterised by the presence of the neuropeptides substance P and dynorphin and by the preferential expression of the D1 sub-type of dopamine receptors. On the other hand, the sub-population that gives rise to the indirect pathway expresses preferentially enkephalin and the D2 sub-type of dopamine receptors<sup>10</sup>. Imbalance in the activity of these two pathways underlies some of the motor deficits in Parkinson's disease<sup>10,68,70</sup>.

The model of direct and indirect pathways as originally introduced, was by necessity, a simplification and only included the major projections of sub-nuclei of the basal ganglia. However, since its introduction there have been many developments in our knowledge and understanding of the anatomical and synaptic organisation of the basal ganglia that leads to reconsider and update some aspects of the model. One of the most important new finding regarding the anatomical organization of the basal ganglia is the demonstration of multiple indirect pathways of information flow through the basal ganglia. In addition to the classical indirect pathway through the GPe and the STN, it is now well established that the GPe gives rise to GABAergic projections that terminate in basal ganglia output structures (GPi, SNr) and the reticular nucleus of the thalamus<sup>6,12,13</sup>. A projection from the GPe to the striatum which, in rats, target preferentially subpopulations of striatal interneurons<sup>71</sup> has also been described<sup>6,12,13</sup>. Although the exact functions of these connections remains unknown, it should be kept in mind that the circuitry of the basal ganglia as outlined in the original model of "direct and indirect" pathways is likely to be more complex than previously thought<sup>12</sup>.

It is worth noting that molecular and anatomical data challenged to organization of the direct and indirect pathways. On one hand, the use of RT-PCR techniques showed a higher level of co-localization of D1 and D2 receptors than revealed by *in situ* hybridization methods in striatal neurons (see ref. 10 for review). However, the relative abundance of the two receptor subtypes in direct and indirect striatofugal neurons is strikingly different which is consistent with *in situ* hybridization data. Indirect striatofugal neurons that contain enkephalin express high

levels of D2 mRNA and low level of D1 mRNA whereas direct striatofugal neurons that contain substance P express high levels of D1 mRNA but also show low levels of D2 mRNA expression. The only striatal projection neurons that co-express high levels of D1 and D2 receptor subtypes are a small population of projection neurons that contain both enkephalin and substance P. Another set of data that led to reconsider some aspects of the model are those obtained in recent intracellular staining studies showing that the segregation of striatofugal neurons into striatopallidal and striatonigral neurons is not as clear-cut as originally suggested based on differential peptide expression and retrograde double labeling studies (see ref. 10 for review). It appears that striatal projection neurons innervate, to some extent, both pallidal segments and the substantia nigra in rats and monkeys <sup>10</sup>. Kawaguchi et al. divided striatofugal neurons into two major types based on their pattern of axonal arborization. A first type of neurons, referred to as "indirect" striatofugal neurons, have axons that arborize profusely and exclusively in the globus pallidus. A second type of neurons, referred to as "direct" striatofugal neurons, project massively to the entopeduncular nucleus and/or the substantia nigra, but also send thin axon collaterals to the globus pallidus <sup>10</sup>. Although this does not rule out the concept of segregation of striatofugal neurons, these findings must be kept in mind while considering the functional significance of the direct and indirect striatofugal pathways.

#### Glutamate and GABA Receptors in the Globus Pallidus

As discussed above, GABA and glutamate are the two main transmitters that mediate activity along the direct and indirect pathways of the basal ganglia. Pallidal neurons receive massive axo-dendritic GABAergic inputs from the striatum and strong somatic innervation from local collaterals of GPe neurons. The glutamatergic terminals from the STN, which account for less than 10% of the total population of boutons in contact with pallidal neurons, are homogeneously distributed among GABAergic terminals on neuronal cell bodies and dendrites (Fig.3). The effects of GABA and glutamate on pallidal neurons depend, not only on the subtype

and subunit composition of the receptors expressed by the postsynaptic neurons, but also on their spatial relationships to glutamate and GABA release sites. In this respect, pallidal neurons express various NMDA and AMPA receptor subunits in the core of asymmetric glutamatergic synapses in the rat pallidum<sup>41,72</sup>. Pallidal neurons are also enriched in group I (mGluR1 and mGluR5) metabotropic glutamate receptors<sup>43</sup>. Surprisingly, both subtypes of group I mGluRs were found postsynaptically in the core of striatopallidal GABAergic synapses and perisynaptically at subthalamopallidal glutamatergic synapses in monkeys<sup>48,73</sup> (Fig. 4). However, pallidal neurons express low levels of group II mGluRs which, on the other hand, abound in glial cells<sup>43,49,50</sup>. Finally, the group III mGluRs (mGluR4a and mGluR7a,b) are mostly expressed presynaptically in striatopallidal GABAergic terminals where they may act as heteroreceptor to modulate GABA release from striatal terminals<sup>45,46</sup> (Fig. 4).

As expected, pallidal neurons also express moderate to high level of GABA-A and GABA-B receptors<sup>53,58,59,60</sup>. The GABA-A receptor subunits are mostly found postsynaptically in the core of symmetric striatopallidal GABAergic synapses<sup>60,74,75</sup> whereas the GABA-B receptors are present on the post-synaptic membrane of striatopallidal synapses, perisynaptic to asymmetric synapses and presynaptic in subthalamic glutamatergic terminals<sup>48,59</sup> (Fig. 4). These data indicate that GABA-B receptors may act at various sites to modulate both the GABAergic and glutamatergic neurotransmission in the pallidal complex.

#### *Differential Innervation of Direct and Indirect Striatofugal Neurons and Interneurons*

Although all medium spiny striatofugal neurons display a similar pattern of synaptic innervation, recent evidence indicates that some extrinsic afferents target preferentially direct or indirect striatal projection neurons (Fig. 5). For instance, thalamic inputs from CM form synapses much more frequently with direct than indirect striatofugal neurons in squirrel monkeys<sup>27</sup> (Fig. 5). On the other hand, sensorimotor cortical inputs influence preferentially striato-GPe neurons in rats<sup>76</sup> and monkeys<sup>77</sup>. After microstimulation of physiologically corresponding sites

in M1 and S1, 75% of the striatofugal neurons that displayed c-fos immunoreactivity, ie those neurons that changed their activity, were enkephalin-immunoreactive, indicating that they give rise to the indirect pathways. Whether or not those functional effects were mediated by a differential density of sensorimotor cortical terminals in contact with striato-GPe and striato-GPi neurons remain to be established. At least, such does not seem to be the case in rats, since inputs from the motor cortex form synapses more frequently with neurons of the direct pathway than those of the indirect pathways<sup>78</sup>.

It is noteworthy that this differential synaptic innervation was also found at the level of striatal interneurons. For example, cholinergic interneurons receive massive inputs from thalamic intralaminar nuclei but are much less innervated by cortical afferents<sup>20,74,79</sup>. On the other hand, calretinin-immunoreactive interneurons appear to be devoid of CM inputs whereas parvalbumin- and somatostatin-containing neurons receive both CM and cortical inputs in monkeys<sup>79</sup>. In rats, parvalbumin-containing neurons are preferentially innervated by cortical afferents<sup>33</sup>.

### **The Cortico- and Thalamo-Subthalamic Projections: Additional Entrances to the Basal Ganglia Circuitry**

As is the case for the striatum, the STN also receives excitatory glutamatergic projections from the cerebral cortex. In primates, anatomical evidence indicate that the cortico-subthalamic projection is exclusively ipsilateral and arises mainly from the primary motor cortex (area 4), with a minor contribution of prefrontal and premotor cortices. Somatosensory and visual cortical areas do not project to the STN but innervate substantially the striatum. Attempts to determine the exact origin of cortico-subthalamic projections in cat and monkey by retrograde transport have been inconclusive. In rats, however, the cortico-subthalamic projection originates mainly

form layer V neurons which, in some cases, send axon collateral to the striatum. In both rat and monkey, the cortico-subthalamic projection is topographically organized so that afferents from the primary motor cortex (M1) are confined to the dorsolateral part of the STN, whereas the premotor (areas 8, 9 and 6), supplementary motor and pre-supplementary motor areas as well as adjacent frontal cortical regions innervate preferentially the medial third of the nucleus. On the other hand, inputs from the prefrontal-limbic cortices are confined to the medialmost tip of STN<sup>6,12,13</sup>. By virtue of its cortical inputs, the dorsolateral sector of the STN is involved in the control of motor behaviors, whereas the ventromedial sector processes oculomotor, associative and limbic information<sup>12,13</sup>.

Like cortical afferents to the striatum, the cortico-subthalamic projection from M1 is somatotopically organized; the face area projects laterally, the arm area centrally and the leg area medially. Interestingly, the arrangement of somatotopical representations from the supplementary motor area (SMA) to the medial STN is reversed against the ordering from M1 to the lateral STN in macaque monkeys<sup>80</sup>. Therefore, the cerebral cortex imposes a specific functional segregation not only upon the striatum, but also at the level of the STN<sup>81</sup>. However, it is worth noting that STN neurons have long dendrites that may cross boundaries of functional territories imposed by cortical projections in rats<sup>82</sup>. This anatomical arrangement opens up the possibility for some functionally segregated information at the level of the cerebral cortex to converge on individual STN neurons in rodents.

As described for the striatum, another source of excitatory inputs to the STN arises from the CM/PF nuclear complex. No other thalamic nuclei are known to innervate the STN. The thalamo-subthalamic projection arborizes ipsilaterally in discrete portions of the STN. This input respects the functional organization of the STN, ie sensorimotor neurons in CM terminate preferentially in the dorsolateral part of the nucleus whereas limbic-and associative -related neurons in PF project almost exclusively to the medial STN. In rats, the thalamo-subthalamic projection is excitatory and tonically drives the activity of STN neurons. Although some PF neurons that project to the striatum send axon collaterals to the STN, the thalamo-subthalamic

and thalamo-striatal projections largely arise from segregated populations of PF neurons in rats

83

Even if cortical and thalamic inputs are relatively sparse and terminate on the distal dendrites and spines of STN neurons, electrophysiologic experiments showed that activation of these inputs results in very strong short latency monosynaptic excitatory postsynaptic potentials (EPSP) in STN neurons. Furthermore, it is worth noting that the information flowing through the STN reaches basal ganglia output structures much faster than information transmitted along the striatofugal pathways<sup>84,85,86</sup>. These anatomical and electrophysiological data, therefore, suggest that the STN is another main entrance of information to the basal ganglia circuitry.

#### GABA and Glutamate Receptors in the STN

STN neurons display strong immunoreactivity for various GABA-A receptor subunits<sup>75</sup>, which is consistent with electrophysiological studies showing that the pallidal inhibition of STN neurons is largely mediated by GABA-A receptor activation. In addition, subpopulations of STN neurons display moderate immunoreactivity for GABA-B receptors<sup>59</sup>. At the electron microscope level, GABA-B receptors were found to be expressed post-synaptically on dendrites of STN neurons and pre-synaptically in putative glutamatergic axon terminals<sup>59</sup>. Together, these data indicate that both GABA-A and GABA-B receptors are likely to mediate post-synaptic inhibition from GPe in STN neurons. In addition, GABA-B receptors may also control the activity of STN neurons by pre-synaptic inhibition of neurotransmitter release from extrinsic and/or intrinsic glutamatergic terminals.

STN neurons express high level of immunoreactivity for various NMDA and AMPA glutamatergic receptor subunits. Ultrastructural analysis revealed that both types of ionotropic glutamate receptors are expressed preferentially in the postsynaptic membrane of putative glutamatergic synapses, though AMPA receptor subunit immunoreactivity was also found at symmetric GABAergic synapses in rats<sup>72</sup>. Although the synaptic localization of mGluRs has not been studied in great detail in the STN, preliminary data indicate that group I mGluRs are found

post-synaptically at the edges of asymmetric glutamatergic synapses or in the main body of symmetric GABAergic synapses<sup>87</sup>. A particular feature that characterizes STN neurons is their strong expression of group II (mGluR2) mGluR mRNAs relative to other populations of basal ganglia neurons<sup>43</sup>. Consistent with this, group II mGluR agonists reduce STN-mediated EPSPs in rat SNr neurons. These effects are likely to be mediated by activation of pre-synaptic mGluR2 receptors expressed on STN axons and terminals in the SNr. Very low levels of group III mGluRs mRNAs were found in STN neurons<sup>43,44</sup>.

## **The Motor Thalamus: A Major Target of Basal Ganglia and Cerebellar**

### **Outflow**

The GPi and the SNr are the two output structures of the basal ganglia. They convey basal ganglia outflow to motor, cognitive, and intralaminar thalamic nuclei as well as various brainstem structures (Fig. 1). In the following account we will discuss the organization of basal ganglia projections from GPi and SNr to the thalamus and compare the pattern of distribution of basal ganglia inputs with that of cerebellar afferents.

### **Nomenclature of Motor Thalamic Nuclei**

The motor thalamus comprises the ventral anterior (VA)/ventral lateral (VL) nuclear group. Various nomenclatures have been introduced for the terminology of the subdivisions of motor thalamic nuclei in primates (Table 1). To facilitate the comparison of data obtained in different studies it is important to note the correspondence between these terminology. Table 1 compares the nomenclature of VA/VL subdivisions introduced by various groups to define motor thalamic nuclei in Old World<sup>88,89,90a</sup> and New World<sup>91</sup> monkeys. For further details on the nomenclature of thalamic nuclei in humans and non-human primates, readers are referred to a recent extensive review by Percheron et al.<sup>92</sup>.

Basal Ganglia and Cerebellar Inputs to Motor Thalamic Nuclei

Although both the GPi and SNr project to the VA/VL, the nigral and pallidal afferents largely terminate in different subdivisions of the VA/VL nuclei<sup>93,94</sup>, which were originally thought to be completely separate from cerebellar projection sites in the primate thalamus<sup>89,93</sup>. However, recent investigations using multiple labeling techniques have demonstrated that, even if cerebellar and pallidal projections mainly innervate different thalamic nuclei, a substantial level of convergence exists between these two major thalamic afferents<sup>95,96,97,98</sup>. These observations led to reconsider some aspects of basal ganglia thalamocortical relationships taking into consideration that basal ganglia information is not only conveyed to premotor (PM) and supplementary motor (SMA) cortical areas but also reach the primary motor cortex (MI). Conversely, the cerebellar outflow, which was thought to be conveyed exclusively to MI, also reaches PM and SMA cortical regions<sup>95,96,97,98,99</sup>.

Another important concept that has been emphasized over the past few years is that both cerebellar and basal ganglia thalamic projections, not only terminate in motor thalamic territories, but also reach major associative and limbic regions of the primate thalamus (see ref. 99 for a review). Although the non-motor functions of basal ganglia and cerebellum have long been known, a series of recent anatomical data clearly demonstrated the existence of various connections through which basal ganglia and cerebellar information can reach various cortical areas in the frontal, parietal and temporal lobes known to be involved in cognitive functions (see ref. 99 for details). The use of transsynaptic retrograde virus transport following injections in various cortical areas led Strick et al.<sup>99</sup> to propose that nigral, pallidal and cerebellar outputs to the cerebral cortex flow through various channels which arise from segregated regions of basal ganglia output structures and deep cerebellar nuclei (Fig. 6).

The Nigrothalamic Projection: The ventral anterior and mediodorsal thalamic nuclei are the main targets of nigrothalamic projections in primates<sup>6,94</sup>. In an elegant anatomical study combining anterograde and retrograde labeling methods, Ilinsky et al.<sup>94</sup> came to the following conclusions regarding the nigrothalamocortical projections in monkeys: (1) Inputs from the medial part of the SNr terminate mostly in the medial magnocellular divisions of the VA (VAmc) and the mediodorsal nucleus (MDmc) which, in turn, innervate anterior regions of the frontal lobe including the principal sulcus (Walker's area 46) and the orbital cortex (Walker's area 11), (2) Neurons in the lateral part of the SNr project preferentially to the lateral posterior region of the VAmc, and to different parts of MD mostly related to posterior regions of the frontal lobe including the frontal eye field and areas of the premotor cortex. On the basis of recent retrograde transsynaptic viral tracing studies, Strick et al.<sup>99</sup> extended these findings and proposed that the nigral outputs to the thalamus flow along five separate channels which target various cortical areas involved in cognitive, sensory and oculomotor functions (Fig.6). Another thalamic target of SNr neurons is the caudal intralaminar parafascicular nucleus<sup>94,100</sup>. The organization of this projection is further discussed in a separate section.

The Pallidothalamic Projection: The main thalamic targets of GPi neurons are the VA/VL and caudal intralaminar thalamic nuclei<sup>6,101</sup>. Efferents from the sensorimotor GPi remain largely segregated from the associative and limbic projections at the level of the thalamus whereas they partly overlap in the PPN<sup>101,102</sup>. On the other hand, limbic and associative pallidal projections innervate common nuclei in the thalamus and PPN<sup>101,102</sup>. In squirrel monkeys, the sensorimotor GPi outputs are directed towards the posterior VL (VLp), whereas the associative and limbic GPi innervate preferentially the parvocellular ventral anterior (VApc) and the dorsal VL (VLd). The ventromedial nucleus receives inputs from the limbic GPi only<sup>101</sup>. These findings, therefore, reveal that some associative and limbic cortical information, which is largely processed in segregated corticostriatopallidal channels, converge to common thalamic nuclei in monkeys<sup>101</sup>. Once it has been processed at the thalamic level, the basal ganglia influences are conveyed to the

cerebral cortex via the VA/VL. Retrograde transneuronal virus studies showed that different populations of GPi neurons project to thalamocortical neurons directed towards SMA, M1 and PM<sup>99</sup>, each of these projections being involved in the control of various aspects of skeletomotor activity (Fig.6). On the other hand, the cognitive information from the dorsal part of GPi is transmitted to prefrontal cortical areas 9 and 46 involved in planning and spatial working memory via the VApC (Fig.6) (see ref. 99 for a review). It is noteworthy that about 10-20% of pallidothalamic neurons in the monkey GPi project to the contralateral VA/VL<sup>102a</sup>.

The Cerebellothalamic Projection: As mentioned above, cerebellar afferents are partly segregated from nigral and pallidal projections in the primate thalamus. Although the cerebellum is commonly seen as a brain region involved in skeletomotor control, the importance of this structure in cognitive functions is now well established (see refs. 99, 103 for reviews). In support of such non-motor cerebellar functions, anatomical studies indicate that the dentate nucleus gives rise to, at least, two different channels of cognitive cerebello-thalamo-cortical information in monkeys (Fig. 6). These two circuits, which largely arise from the ventral part of the dentate nucleus, reach cortical areas 9 and 46 via relays in specific parts of the ventrolateral and mediodorsal nuclei (Fig. 6). On the other hand, the skeletomotor-related outflow reaches premotor and primary motor cortical areas via relays in area X and VPLo, respectively. Finally, cerebellar information related to eye movement arises from the caudal part of the dentate nucleus and reaches the frontal eye field cortical area via area X (Fig.6). Although cerebellar projections to the intralaminar thalamic nuclei have been described in non-primates<sup>89,104,105</sup>, the existence of such connections still remains to be established in monkeys (see below).

#### Basal Ganglia Inputs to Intralaminar Thalamic Nuclei

Most pallidal neurons which project to thalamic relay nuclei send axon collaterals to the caudal intralaminar nuclei where they follow a highly specific pattern of distribution<sup>6,101</sup>. Pallidal

axons arising from the sensorimotor GPi terminate exclusively in CM where they form synapses with thalamostriatal neurons projecting back to the sensorimotor territory of the striatum<sup>101</sup> (Fig. 7). In contrast, associative inputs from the caudate-receiving territory of GPi terminate massively in a dorsolateral extension of PF (PFdl) which, surprisingly, does not project back to the caudate nucleus but rather innervates preferentially the pre-commissural region of the putamen (Fig. 7). Finally, the limbic GPi innervates selectively the rostradorsal part of PF which, in turn, projects back to the nucleus accumbens. On the other hand, SNr projections are confined to the PF where they largely overlap with thalamostriatal neurons projecting to the caudate nucleus<sup>100</sup>. Therefore, it appears that the CM/PF is part of closed and open functional loops with the striatopallidal complex (Fig. 7).

### **Descending Pallidal and Nigral Projections to the Tegmental Pedunculopontine Nucleus**

In monkeys, more than 80% of GPi neurons that project to the TPP send axon collaterals to the ventral thalamus<sup>6</sup>. In contrast to the VL, which largely conveys basal ganglia information to the cerebral cortex, the TPP gives rise to descending projections to the pons, medulla and spinal cord as well as prominent ascending projections to the different structures of the basal ganglia, the thalamus and the basal forebrain<sup>105,106,107,108</sup>. The pallidotegmental projection may thus be a route by which information can escape from the basal ganglia-thalamocortical circuitry and reach lower motor and autonomic centers. Another possibility is that the TPP acts as an interface between different functional territories of the GPi, and send back the integrated information to the basal ganglia circuitry mainly via its massive projection to the dopaminergic neurons of the SNc<sup>6,13</sup>. We recently investigated the pattern of distribution of functionally segregated pallidofugal information in the TPP of squirrel monkeys<sup>102</sup>. The results of this study are summarized in Fig. 8. Injections of anterograde tracers in different functional territories of the GPi lead to anterograde labelling that largely converges to common regions of the so-called,

pars diffusa of the TPP (TPPd). The fields of fibres that arise from the associative and limbic territories of the GPi are more widely spread than the afferents from the sensorimotor territory of the GPi. Another major finding of this study is that pallidal fibers largely avoid cholinergic neurons in the pars compacta of the TPP. These anatomical data, therefore, suggest that the non-cholinergic neurons of the TPPd are potential targets for the integration of information arising from different functional territories of the GPi in primates. The TPPd is thus in a position to act as an interface between motivational, cognitive and motor information transmitted along the pallidotegmental projection in primates (Fig. 8).

The SNr also provide substantial inputs to cholinergic and non-cholinergic neurons of the TPP in rats<sup>109,110</sup>. Although the existence of this projection has been shown in monkeys by means of retrograde labelling studies<sup>6</sup>, the exact targets of nigrosegmental projections remains to be established.

### Concluding Remarks

Our knowledge of the basal ganglia anatomy has increased tremendously over the past ten years mainly due to the introduction of highly sophisticated and sensitive tract-tracing and immunocytochemical methods suitable with light and electron microscope analysis. This review highlights recent anatomical data which lead to reconsider some aspects of the functional circuitry of the basal ganglia. For instance, the thalamostriatal projection, which is largely neglected in functional models of basal ganglia connectivity surely deserves attention. This projection is very massive and follows a highly specific pattern of functional connectivity with the striatopallidal complex. The fact that thalamic inputs are directed preferentially towards specific populations of striatal projection neurons and interneurons strongly indicate that these inputs may play a major role in the basal ganglia circuitry. Another important concern raised over the past few years relates to the validity of the "direct" and "indirect" pathways of the basal ganglia. The evidence that subpopulations of striatofugal neurons express both D1 and D2

dopamine receptors combined to the fact that striatofugal neurons are more collateralized than previously thought, challenged the concept of segregation of striatal projection neurons. However, despite these anatomical refinements of the basal ganglia circuitry, it is clear that the functional concept of "direct" and "indirect" pathways still remains the basic working model for understanding changes in the basal ganglia circuitry in pathological conditions and developing more accurate surgical and pharmacological therapies for basal ganglia diseases. Another critical aspect of the basal ganglia circuitry which should deserve attention in the next few years is the relative importance of the subthalamic nucleus and the striatum as major entrances of cortical information to the basal ganglia. Although the striatum receives a much more massive input from the cerebral cortex and thalamus than the subthalamic nucleus, the fact that the information flowing through the cortico/thalamo-subthalamic projections reach the output structures of the basal ganglia (GPI, SNr) before the information travelling through the striatum deserves consideration. The long term belief that the basal ganglia and cerebellum were solely involved in motor behaviors should definitely be abandoned in light of various behavioral and clinical studies showing the clear implication of these brain regions in cognitive functions. Furthermore, the anatomical data presented in this review demonstrate that both basal ganglia and cerebellar outflow have access not only to motor-related cortical areas, but rather invade large regions of the frontal, temporal and parietal lobes devoted to various aspects of cognitive behaviors.

Finally, the large amount of neurotransmitters and neuropeptides involved in mediating synaptic communication between structures of the basal ganglia, makes the chemical pedigree of basal ganglia structures extremely complex. Data presented in this review showing that G protein-coupled glutamate and GABA receptors are largely expressed extrasynaptically or at synapses unrelated to the release site of their stimulating neurotransmitter further enhance this complexity and raise exciting issues about the functions and mechanisms of activation of metabotropic receptors in the basal ganglia.

## ACKNOWLEDGEMENTS

The authors acknowledge Jean-François Paré, Jeremy Kieval for technical assistance, Frank Kiernan for photography and Peggy Plant for clerical work. This work was supported by NIH grants R01-37423, R01-37948 and RR 00165. Ali Charara holds a fellowship from the FCAR.

## REFERENCES

1. Graybiel AM: Neurotransmitters and neuromodulators in the basal ganglia. *Trends Neurosci* 13: 244-254, 1990.
2. Alexander GE, Crutcher MD: Functional architecture of basal ganglia circuits: Neural substrates of parallel processing. *Trends Neurosci* 13: 266-271, 1990.
3. Smith AD, Bolam JP: The neural network of the basal ganglia as revealed by the study of synaptic connections of identified neurons. *Trends Neurosci* 13: 259-265, 1990.
4. Joel D, Weiner I: The organization of the basal ganglia-thalamocortical circuits: open interconnected rather than closed segregated. *Neuroscience* 63: 363-379, 1994
5. Joel D, Weiner I: The connections of the primate subthalamic nucleus: indirect pathways and the open-interconnected scheme of basal ganglia-thalamocortical circuitry. *Brain Res Rev* 23: 62-78, 1997.
6. Parent A, Hazrati L-N: Functional anatomy of the basal ganglia. I. The cortico-basal ganglia-thalamo-cortical loop. *Brain Res Rev* 20: 91-127, 1995
7. Wilson CJ: Basal ganglia. *In* *The Synaptic Organization of the Brain*, Chapt 9, New York, Oxford Univ Press, 1998, pp 329-375.
8. Wilson CJ: The contribution of cortical neurons to the firing pattern of striatal spiny neurons. *In* Houk JC, Davis JL, Beiser DG (eds): *Models of information processing in the basal ganglia*, Cambridge, MA, MIT Press, 1995, pp 29-50.

9. Chesselet M-F, Delfs JM: Basal ganglia and movement disorders: an update. *Trends Neurosci* 19: 417-422, 1996.
10. Gerfen CR, Wilson CJ: The basal ganglia. *In* Björklund A, Hökfelt T, Swanson L (eds): *Handbook of Chemical Neuroanatomy, Integrated Systems of the CNS, Part III*, Amsterdam, Elsevier, 1996, pp 369-466.
11. Levy R, Hazrati L-N, Herrero M-T, et al.: Re-evaluation of the functional anatomy of the basal ganglia in normal and parkinsonian states. *Neuroscience* 76: 335-343, 1997.
12. Smith Y, Bevan MD, Shink E, et al.: Microcircuitry of the direct and indirect pathways of the basal ganglia. *Neuroscience* 86: 353-387, 1998.
13. Smith Y, Shink E, Sidibé M: Neuronal circuitry and synaptic connectivity of the basal ganglia. *In* Bakay AE (ed.): *Neurosurgery Clinics of North America*, Philadelphia, WB Saunders, 1998, pp 203-222.
14. Parthasarathy HB, Schall JD, Graybiel AM: Distributed but convergent ordering of corticostriatal projections: Analysis of the frontal eye field and the supplementary eye field in the macaque monkey. *J Neurosci* 12: 4468-4488, 1992.
15. Selemon LD, Goldman-Rakic PS: Longitudinal topography and interdigitation of corticostriatal projections in the rhesus monkey. *J Neurosci* 5: 776-794, 1990.

16. Flaherty AW, Graybiel AM: Corticostriatal transformation in the primate somatosensory system. Projections from physiologically mapped body-part representations. *J Neurophysiol* 66: 1249-1263, 1991.
17. Flaherty AW, Graybiel AM: Two input systems for body representations in the primate striatal matrix: experimental evidence in the squirrel monkey. *J Neurosci* 13: 1120-1137, 1993.
18. Kawaguchi Y, Wilson CJ, Augood SJ, et al.: Striatal interneurons: Chemical, physiological and morphological characterization. *Trends Neurosci* 18: 527-535, 1995.
19. Lapper SR, Smith Y, Sadikot AF, et al.: Cortical input to parvalbumin-immunoreactive neurons in the putamen of the squirrel monkey. *Brain Res* 580: 215-224, 1992.
20. Meredith GE, Wouterlood FG: Hippocampal and midline thalamic fibers and terminals in relation to the choline acetyltransferase-immunoreactive neurons in nucleus accumbens of the rat: A light and electron microscopic study. *J Comp Neurol* 296: 204-221, 1990
21. Lapper SR, Bolam JP: Input from the frontal cortex and the parafascicular nucleus to cholinergic interneurons in the dorsal striatum of the rat. *Neuroscience* 51: 533-545, 1992
22. Kawaguchi Y, Wilson CJ, Emson PC: Projection subtypes of rat neostriatal matrix cells revealed by intracellular injection of biocytin. *J Neurosci* 10:3421, 1990
23. Jaeger D, Kita H, Wilson CJ: Surround inhibition among projection neurons is weak or nonexistent in the rat neostriatum. *J Neurophysiol* 72: 2555-2558, 1994.

24. Johnson LM, Koos T, Zaborszky L, et al.: GABAA receptor-mediated inhibition of medium spiny neurons by fast spiking interneurons in rat neostriatum. *Soc Neurosci Abstr* 23: 504.10, 1997.
25. Groenewegen HJ and Berendse HW: The specificity of the nonspecific midline and intralaminar thalamic nuclei. *Trends Neurosci* 17: 52-57, 1994.
26. Sadikot AF, Parent A, Smith Y, et al.: Efferent connections of the centromedian and parafascicular nuclei in the squirrel monkey: A light and electron microscopic study of the thalamostriatal projection in relation to striatal heterogeneity. *J Comp Neurol* 320: 228-242, 1992.
27. Sidibé M, Smith Y: Differential synaptic innervation of striatofugal neurons projecting to the internal or external segments of the globus pallidus by thalamic afferents in the squirrel monkey. *J Comp Neurol* 365: 445-465, 1996.
28. Smith Y, Sidibé M: Functional interconnections between the caudal intralaminar nuclei and the striatopallidal complex in monkeys. *Soc Neurosci Abstr* 25: 884.19, 1999.
29. Dubé L, Smith AD, Bolam JP: Identification of synaptic terminals of thalamic and cortical origin in contact with distinct medium-sized spiny neurons in the rat neostriatum. *J Comp Neurol* 267: 455-471, 1988
30. Xu ZC, Wilson CJ, Emson PC: Restoration of thalamostriatal projections in rat neostriatal grafts: An electron microscopic analysis. *J Comp Neurol* 303: 22-34, 1991.

31. Smith Y, Bennett BD, Bolam JP, et al.: Synaptic relationships between dopaminergic afferents and cortical or thalamic input to the sensorimotor territory of the striatum in monkey. *J Comp Neurol* 344: 1-19, 1994.
32. Sidibé M, Smith Y: Thalamic inputs to striatal interneurons in monkeys: Synaptic organization and co-localization of calcium binding proteins. *Neuroscience* 89: 1189-1208, 1999.
33. Rudkin TM, Sadikot AF: Thalamic input to parvalbumin-immunoreactive GABAergic interneurons: Organization in normal striatum and effect of neonatal decortication. *Neuroscience* 88: 1165-1175, 1999.
34. Smith Y, Parent A: Differential connections of caudate nucleus and putamen in the squirrel monkey (*Saimiri sciureus*). *Neuroscience* 18:347-371, 1986.
35. McFarland NR, Haber SN: Convergent inputs from thalamic motor nuclei and frontal cortical areas to the dorsal striatum in the primate. *J Neurosci* 20:3798-3813, 2000.
36. Standaert DG, Testa CM, Penney JB, et al.: Organization of N-methyl-D-aspartate glutamate receptor gene expression in the basal ganglia of the rat. *J Comp Neurol* 343: 1-16, 1994.
37. Kosinski CM, Standaert DG, Coughlin TJ, et al.: Expression of N-methyl-D-aspartate receptor subunit mRNAs in the human brain: Striatum and globus pallidus. *J Comp Neurol* 390: 63-74, 1998.
38. Bernard, V, Somogyi P, Bolam JP: Cellular, subcellular, and subsynaptic distribution of AMPA-type glutamate receptor subunits in the neostriatum of the rat. *J Neurosci* 17: 819-833, 1997.

39. Bischoff S, Barhanin J, Bettler B, et al.: Spatial distribution of kainate receptor subunit mRNA in the mouse basal ganglia and ventral mesencephalon. *J Comp Neurol* 379: 541-562, 1997.
40. Wüllner U, Standaert DG, Testa CM, et al.: Differential expression of kainate receptors in the basal ganglia of the developing and adult rat brain. *Brain Res* 768: 215-223, 1997.
41. Bernard V, Bolam JP: Subcellular and subsynaptic distribution of NR1 subunit of the NMDA receptor in the neostriatum and globus pallidus of the rat: co-localization at synapses with the GluR2/3 subunit of the AMPA receptor. *Eur J Neurosci* 10: 3721-3736, 1998
42. Charara A, Blankstein E, Smith Y: Presynaptic kainate receptor in the monkey striatum. *Neuroscience* 91: 1195-1200, 1999.
43. Testa CM, Standaert DG, Young, AB, et al.: Metabotropic glutamate receptor mRNA expression in the basal ganglia of the rat. *J Neurosci* 14: 3005-3018, 1994.
44. Ohishi H, Akazawa C, Shigemoto R, et al.: Distribution of the mRNAs for L-2-amino-4-phosphonobutyrate-sensitive metabotropic glutamate receptors, mGluR4 and mGluR7, in the rat brain. *J Comp Neurol* 360: 555-570, 1995.
45. Kinoshita A, Shigemoto R, Ohishi H, et al.: Immunohistochemical localization of metabotropic glutamate receptors, mGluR7a and mGluR7b, in the central nervous system of the adult rat and mouse: A light and electron microscopic study. *J Comp Neurol* 393: 332-352, 1998.

46. Bradley SR, Standaert DG, Rhodes KJ, et al.: Immunohistochemical localization of subtype 4a metabotropic glutamate receptors in the rat and mouse basal ganglia. *J Comp Neurol* 407: 33-46, 1999.
47. Paquet M, Bradley SR, Conn PJ, et al.: Subcellular and subsynaptic distribution of metabotropic glutamate receptors in the monkey striatum. *Soc Neurosci Abstr* 25: 445, 1999.
48. Smith Y, Charara A, Hanson JE, et al.: GABAB and group I metabotropic glutamate receptors in the striatopallidal complex in primates. *J Anat* 196: 555-576, 2000.
49. Ohishi H, Shigemoto R, Nakanishi S, et al.: Distribution of the mRNA for a metabotropic glutamate receptor (mGluR3) in the rat brain: An *in situ* hybridization study. *J Comp Neurol* 335: 252-266, 1993.
50. Ohishi H, Shigemoto R, Nakanishi S, et al.: Distribution of the messenger RNA for a metabotropic glutamate receptor, mGluR2, in the central nervous system of the rat. *Neuroscience* 53: 1009-1018, 1993.
51. Testa CM, Friberg IK, Weiss SW, et al.: Immunohistochemical localization of metabotropic glutamate receptors mGluR1a and mGluR2/3 in the rat basal ganglia. *J Comp Neurol* 390: 5-19, 1998.
52. Möhler H, Benke D, Benson J, et al.: Diversity in structure, pharmacology, and regulation of GABAA receptors. In Enna SJ, Bowery NG (eds): *The GABA Receptors*, Totowa NJ, Humana Press, 1997, pp 11-36.

53. Fritschy J-M, Mohler H: GABAA-receptor heterogeneity in the adult rat brain: Differential regional and cellular distribution of seven major subunits. *J Comp Neurol* 359: 154-194, 1995.
54. Jones KA, Borowsky B, Tamm JA, et al.: GABA<sub>B</sub> receptors function as heteromeric assembly of the subunits GABA<sub>B</sub>R1 and GABA<sub>B</sub>R2. *Nature* 396: 674-679, 1998.
55. Kaupmann K, Malitschek B, Schuler V, et al.: GABA<sub>B</sub>-receptor subtypes assemble into functional heteromeric complexes. *Nature* 396: 683-687, 1998.
56. Kaupmann K, Huggel K, Heid J, et al.: Expression cloning of GABA<sub>B</sub> receptors uncovers similarity to metabotropic glutamate receptors. *Nature* 396: 239-246, 1997.
57. Fritschy J-M, Meskenaite V, Weinmann O, et al.: GABA<sub>B</sub>-receptor splice variants GB1a and GB1b in rat brain: developmental regulation, cellular distribution and extrasynaptic localization. *Eur J Neurosci* 11: 761-768, 1999.
58. Margeta-Mitrovic M, Mitrovic I, Riley RC, et al.: Immunocytochemical localization of GABA<sub>B</sub> receptors in the rat central nervous system. *J Comp Neurol* 405: 299-321, 1999.
59. Charara A, Heilman TC, Levey AI: Pre- and post-synaptic localization of GABA<sub>B</sub> receptors in the basal ganglia in monkeys. *Neuroscience* 95: 127-140, 2000.
60. Waldvogel HJ, Fritschy J-M, Mohler H: GABAA receptors in the primate basal ganglia: An autoradiographic and a light and electron microscopic immunohistochemical study of the  $\alpha$ 1 and  $\beta$ 2/3 subunits in the baboon brain. *J Comp Neurol* 397: 297-325, 1998.

61. Fujiyama F, Fritschy J-M, Stephenson FA, et al.: Synaptic localization of GABA(A) receptor subunits in the striatum of the rat. *J Comp Neurol* 416: 158-172, 2000.
- 61a. Smith Y, Kieval JZ: Anatomy of the dopamine system in the basal ganglia. *Trends Neurosci* 23: 28-33, 2000.
- 61b. Joel D, Weiner I: The connections of the dopaminergic system with the striatum in rats and primates: An analysis with respect to the functional and compartmental organization of the striatum. *Neuroscience* 96: 451-474, 2000.
62. Parent A, Smith Y: Organization of the efferent projections of the subthalamic nucleus in the squirrel monkey as revealed by retrograde labeling methods. *Brain Res* 436: 296-310, 1987
63. Steinbusch HWM, Sauren Y, Groenewegen HJ, et al.: Histaminergic projections from the premammillary and posterior hypothalamic region to the caudate-putamen complex in the rat. *Brain Res* 368: 389-393, 1986.
64. Jackson A, Crossman AR: Nucleus tegmenti pedunculopontinus: Efferent connections with special reference to the basal ganglia, studied in the rat by anterograde and retrograde transport of horseradish peroxidase. *Neuroscience* 10: 725-765, 1983
65. Yasui Y, Itoh K, Mizuno N: Direct projection from the caudal spinal trigeminal nucleus to the striatum in the cat. *Brain Res* 408: 334-338, 1987.

66. Arnault P, Roger M: The connections of the peripeduncular area studied by retrograde and anterograde transport in the rat. *J Comp Neurol* 258: 463-476, 1987.
67. Arikuni T, Kubota K: Substantia innominata projection to caudate nucleus in macaque monkeys. *Brain Res* 302: 184-189, 1984.
68. Albin RL, Young AB, Penney JB: The functional anatomy of basal ganglia disorders. *Trends Neurosci* 12: 366-375, 1989.
69. Alexander GE, Crutcher MD: Functional architecture of basal ganglia circuits: Neural substrates of parallel processing. *Trends Neurosci* 13: 266-271, 1990.
70. Bergman H, Wichmann T, DeLong MR: Reversal of experimental parkinsonism by lesions of the subthalamic nucleus. *Science* 249: 1436-1438, 1990
71. Bevan MD, Booth PA, Eaton SA, et al.: Selective innervation of neostriatal interneurons by a subclass of neurons in the globus pallidus of the rat. *J Neurosci* 18: 9438-9452, 1998.
72. Clarke NP, Bolam JP: Distribution of glutamate receptor subunits at neurochemically characterized synapses in the entopeduncular nucleus and subthalamic nucleus of the rat. *J Comp Neurol* 397: 403-420, 1998
73. Hanson JE, Smith Y: Group I metabotropic glutamate receptors at GABAergic synapses in monkeys. *J Neurosci* 19: 6488-6496, 1999.

74. Somogyi P, Fritschy J-M, Benke D, et al.: The  $\gamma 2$  subunit of the GABA<sub>A</sub> receptor is concentrated in synaptic junctions containing the  $\alpha 1$  and  $\beta 2/3$  subunits in hippocampus, cerebellum and globus pallidus. *Neuropharmacology* 35: 1425-1444, 1996.
75. Charara A, Smith Y: Subsynaptic distribution of GABA<sub>A</sub> receptor subunits in the globus pallidus and subthalamic nucleus in monkeys. *Soc Neurosci Abstr* 24:1650.
76. Berretta S, Parthasarathy HB, Graybiel AM: Local release of GABAergic inhibition in the motor cortex induces immediate-early gene expression in indirect pathway neurons of the striatum. *J Neurosci* 17: 4752-4763, 1997
77. Parthasarathy HB, Graybiel AM: Cortically driven immediate-early gene expression reflects modular influence of sensorimotor cortex on identified striatal neurons in the squirrel monkey. *J Neurosci* 17: 2477-2491, 1997.
78. Hersch SM, Ciliax BJ, Gutekunst C-A, et al.: Electron microscopic analysis of D1 and D2 dopamine receptor proteins in the dorsal striatum and their synaptic relationships with motor corticostriatal afferents. *J Neurosci* 15: 5222-5237, 1995
79. Sidibé M, Smith Y (1999) Thalamic inputs to striatal interneurons in monkeys: Synaptic organization and co-localization of calcium binding proteins. *Neuroscience* 89: 1189-1208, 1999.
80. Nambu A, Takada M, Inase M, et al.: Dual somatotopical representations of the primate subthalamic nucleus: Evidence for ordered but reversed body-map transformations from the primary motor cortex and the supplementary motor area. *J Neurosci* 16: 2671-2683, 1996.

81. Wichmann T, Bergman H, DeLong MR: The primate subthalamic nucleus. I. Functional properties in intact animals. *J Neurophysiol* 72: 494-506, 1994.
82. Bevan MD, Clarke NP, Bolam JP: Synaptic integration of functionally diverse pallidal information in the entopeduncular nucleus and subthalamic nucleus in the rat. *J Neurosci* 17: 308-324, 1997
83. Féger J, Hassani O-K, Mouroux M: The relationships between subthalamic nucleus, globus pallidus and thalamic parafascicular nucleus. In Ohye C, Kimura M, McKenzie JS (eds): *The Basal Ganglia V*, London, Plenum Press, 1995, pp 51-58.
84. Kita H: Physiology of two disynaptic pathways from the sensorimotor cortex to the basal ganglia output nuclei. *In* Percheron G, McKenzie JS, Féger J (eds): *The Basal Ganglia IV, New Ideas and Data on Structure and Function*. (Adv Behav Biol, Vol. 41.). New York, Plenum Press, 1994, pp 263-276.
85. Maurice N, Deniau J-M, Menetrey A, et al.: Prefrontal cortex-basal ganglia circuits in the rat: Involvement of ventral pallidum and subthalamic nucleus. *Synapse* 29: 363-370, 1998.
86. Nambu A, Tokuno H, Hamada I, et al.: Excitatory cortical inputs to pallidal neurons via the subthalamic nucleus in the monkey. *J Neurophysiol* 84:289-300, 2000.
87. Smith Y, Paquet M, Hanson JE, et al.: Subsynaptic localization of group I metabotropic glutamate receptors in the basal ganglia. In Graybiel AM, Kitai ST, DeLong MR (eds): *The Basal Ganglia VI*, New York, Plenum Press, (in press).

88. Olszewski J: The Thalamus of the *Macaca mulatta*. An Atlas for Use with the Stereotaxic Instrument, Basel, Karger, 1952.
89. Jones EG: The Thalamus. New York, Plenum Press, 1985.
90. Ilinsky IA, Kultas-Ilinsky K: Sagittal cytoarchitectonic maps of the *Macaca mulatta* thalamus with a revised nomenclature of motor-related nuclei validated by observations on their connectivity. *J Comp Neurol* 262: 331-364, 1987.
- 90a. Paxinos G, Huang X-F, Toga AW: The rhesus monkey brain in stereotaxic coordinates. San Diego, Academic Press, 2000.
91. Stepniewska I, Preuss TM, Kaas JH: Architectonic subdivisions of the motor thalamus of owl monkeys: Nissl, acetylcholinesterase, and cytochrome oxidase patterns. *J Comp Neurol* 349: 536-556, 1994.
92. Percheron G, François C, Talbi B, et al.: The primate motor thalamus. *Brain Res Rev* 22: 93-181, 1996.
93. Strick PL: How do the basal ganglia and cerebellum gain access to the cortical motor areas? *Behav Brain Res* 18: 107-123, 1985.
94. Ilinsky IA, Jouandet ML, Goldman-Rakic PS: Organization of the nigrothalamocortical system in the rhesus monkey. *J Comp Neurol* 236: 315-330, 1985.

95. Rouillier E., Liang F, Babalian A, et al.: Cerebellothalamocortical and pallidothalamocortical projections to the primary and supplementary motor cortical areas: A multiple tracing study in macaque monkeys. *J Comp Neurol* 345: 185-213, 1994.
96. Sakai ST, Inase M, Tanji J: Comparison of cerebellothalamic and pallidothalamic projections in the monkey (*Macaca fuscata*): A double anterograde labeling study. *J Comp Neurol* 368: 215-228, 1996.
97. Sakai ST, Inase M, Tanji J: Pallidal and cerebellar inputs to thalamocortical neurons projecting to the supplementary motor area in *Macaca fuscata*: A triple-labeling light microscopic study. *Anat Embryol* 199: 9-19, 1999.
98. Sakai ST, Stepniewska I, Hui XQ, et al.: Pallidal and cerebellar afferents to pre-supplementary motor area thalamocortical neurons in the owl monkey: A multiple labeling study. *J Comp Neurol* 417: 164-180, 2000.
99. Middleton FA, Strick PL: Basal ganglia and cerebellar loops: Motor and cognitive circuits. *Brain Res Rev* 31: 236-250, 2000.
100. Smith Y, Sidibé M, Paré, J-F: Synaptic inputs from the substantia nigra and the pedunculo-pontine nucleus to thalamostriatal neurons in monkeys. *Soc Neurosci Abstr* 26: Abstr 5694, 2000.
101. Sidibé M, Bevan MD, Bolam JP, et al.: Efferent connections of the internal globus pallidus in the squirrel monkey: I. Topography and synaptic organization of the pallidothalamic projection. *J Comp Neurol* 382: 323-347, 1997.

102. Shink E, Sidibé M, Smith Y: Efferent connections of the internal globus pallidus in the squirrel monkey: I. Topography and synaptic organization of the pallidal efferents to the pedunculopontine nucleus. *J Comp Neurol* 382: 348-363, 1997.
- 102a. Hazrati L-N, Parent A: Contralateral pallidothalamic and pallidotegmental projections in primates: an anterograde and retrograde labeling study. *Brain Res* 567: 212-223, 1991.
103. Middleton FA, Strick PL: The cerebellum: An overview. *Trends Neurosci* 21: 367-369, 1998
104. Hendry SHC, Jones EG, Graham J: Thalamic relay nuclei for cerebellar and certain related fiber systems in the cat. *J Comp Neurol* 185: 679-714, 1979.
105. Sakai ST, Patton K: Distribution of cerebellothalamic and nigrothalamic projections in the dog: A double anterograde tracing study. *J Comp Neurol* 330: 183-194, 1993.
106. Inglis WL, Winn P: The pedunculopontine tegmental nucleus : Where the striatum meets the reticular formation. *Prog Neurobiol* 47: 1-29, 1995.
107. Rye DB: Contributions of the pedunculopontine region to normal and altered REM sleep. *Sleep* 20: 757-788, 1997.
108. Pahapill PA, Lozano AM: The pedunculopontine nucleus and Parkinson's disease. *Brain* 123: 1767-1783, 2000.

109. Spann BM, Grofova I: Nigropedunculo-pontine projection in the rat: An anterograde tracing study with phaseolus vulgaris-leucoagglutinin (PHA-L). *J Comp Neurol* 311: 375-388, 1991.
110. Grofova I, Zhou M: Nigral innervation of cholinergic and glutamatergic cells in the rat mesopontine tegmentum: Light and electron microscopic anterograde tracing and immunohistochemical studies. *J Comp Neurol* 395: 359-379, 1998.

## FIGURE LEGENDS

**Figure 1:** Simplified schematic diagram of basal ganglia connectivity in primates. For simplification, some connections have been omitted. The different symbols use to label neuronal cell bodies indicate the main neurotransmitter used by these neurons.

**Figure 2:** Schematic drawings of striatal dendrites showing the pattern of subsynaptic distribution of glutamate and GABA receptors in relation to the main striatal afferents in monkeys.

**Figure 3:** Diagram illustrating the pattern of innervation of neurons in both segments of the globus pallidus based on data obtained in squirrel monkeys using anterograde tracing techniques and postembedding immunogold labeling for GABA or glutamate. The relative size and proportion of each category of terminal are represented. The major difference between the innervation of neurons of the two segments of the globus pallidus is that GPi neurons receive strong somatic inputs from GPe, whereas striatal and subthalamic terminals are evenly distributed on GPe and GPi neurons. (Modified from ref. 88).

**Figure 4:** Compartmental (A) and synaptic (B, C) relationships between striatopallidal neurons and thalamic afferents from the centromedian nucleus (CM) in squirrel monkeys. These data were obtained after simultaneous injections of anterograde tracers in CM and retrograde tracers in either segment of the globus pallidus <sup>27</sup>. A: The thalamic inputs project mainly to the matrix striatal compartment that contains neurons projecting to GPe (light gray circles) or GPi (dark gray circles). The large ovoid black areas represent the patch compartment, which does not receive input from CM. The thalamic terminals form asymmetric synapses, frequently with striato-GPi neurons (B) but rarely with striato-GPe cells (C). (Modified from ref. 27).

**Figure 5:** Schematic drawings of pallidal dendrites showing the pattern of subsynaptic distribution of glutamate and GABA receptors in relation to striatal and subthalamic afferents in monkeys.

**Figure 6:** Motor and non-motor connections between basal ganglia output structures or deep cerebellar nuclei and various functional regions of the monkey cerebral cortex. The GPi, SNr and dentate cerebellar nucleus (DN) project to different subdivisions of the VA/VL and the mediodorsal nucleus (MD) which, in turn, reach functionally segregated cortical areas involved in motor, cognitive and sensory functions. The nomenclature of thalamic nuclei used in this diagram is that of Olszewski<sup>88</sup> (See Table 1 and text for details and abbreviations). Reproduced with permission from Ref. 99. Additional abbreviations: AIP: Interpositus nucleus; FEF: Frontal eye field; MDmf: Mediodorsal nucleus, pars multiformis; MDpl: Mediodorsal nucleus, pars lateralis; TE: area of inferotemporal cortex.

**Figure 7:** Schematic diagram illustrating the functional interactions between the basal ganglia and thalamostriatal neurons in monkeys. These data were obtained following simultaneous injections of retrograde tracers in different functional territories of the striatum and anterograde tracers in the corresponding functional regions of GPi or SNr in squirrel monkeys. Note that the caudal intralaminar thalamic nuclei (CM-PF) and the basal ganglia are interconnected by both closed and open functional loops<sup>29,86</sup>.

**Figure 8:** Schematic drawing showing the location of anterograde labeled fibers in the pedunculopontine tegmental nucleus (TPP) following injections of anterograde tracers in the associative, sensorimotor and limbic territories of GPi in squirrel monkeys. Note that projections from the different functional territories of GPi largely overlap in the TPP<sup>87</sup>.

**Table 1:** Nomenclature of various subdivisions of the VA/VL Nuclear Complex in New World<sup>91</sup> and Old World<sup>88,89,90</sup> Monkeys.

Olszewski <sup>88</sup>	VLo	VPLo	Area X	VLc (and VLps)	VLm	VApc	VAmc
Jones <sup>89</sup>	VLa	VLp			VMp	VA	
Ilinsky and Kultas-Ilinsky <sup>90</sup>	VAdc	VL		VLd	VM	VApc	VAmc
Paxinos et al. <sup>90a</sup>	VAL (Vo)	VLL	VLM	VAL	VAM	VAL(Vo)	VAM
Stepniewska et al. <sup>91</sup>	VLa	VLp	VLx	VLd	VM	VApc	VAmc

**Abbreviations:** VA: Ventral anterior nucleus; VAdc: Ventral anterior nucleus, densocellular part; VAL: Ventral anterior nucleus, lateral part; VAM: Ventral anterior nucleus, medial part; VAmc: Ventral anterior nucleus, magnocellular part; VApc: Ventral anterior nucleus, parvocellular part; VL: Ventral lateral nucleus; VLa: Ventral lateral nucleus, anterior division; VLc: Ventral lateral nucleus, pars caudalis; VLd: Ventral lateral nucleus, dorsal division; VLL: Ventral lateral nucleus, lateral part; VLM: ventral lateral nucleus, medial part; VLo: Ventral lateral nucleus, pars oralis; VLp: Ventral lateral nucleus, principal division; VLps: Ventral lateral nucleus, pars posterma; VLx: Ventral lateral nucleus, medial division; VM: Ventral medial nucleus; VMp: Ventral medial nucleus, principal division; Vo: Ventralis oralis nucleus; VPLo: Ventral posterior lateral nucleus, pars oralis;

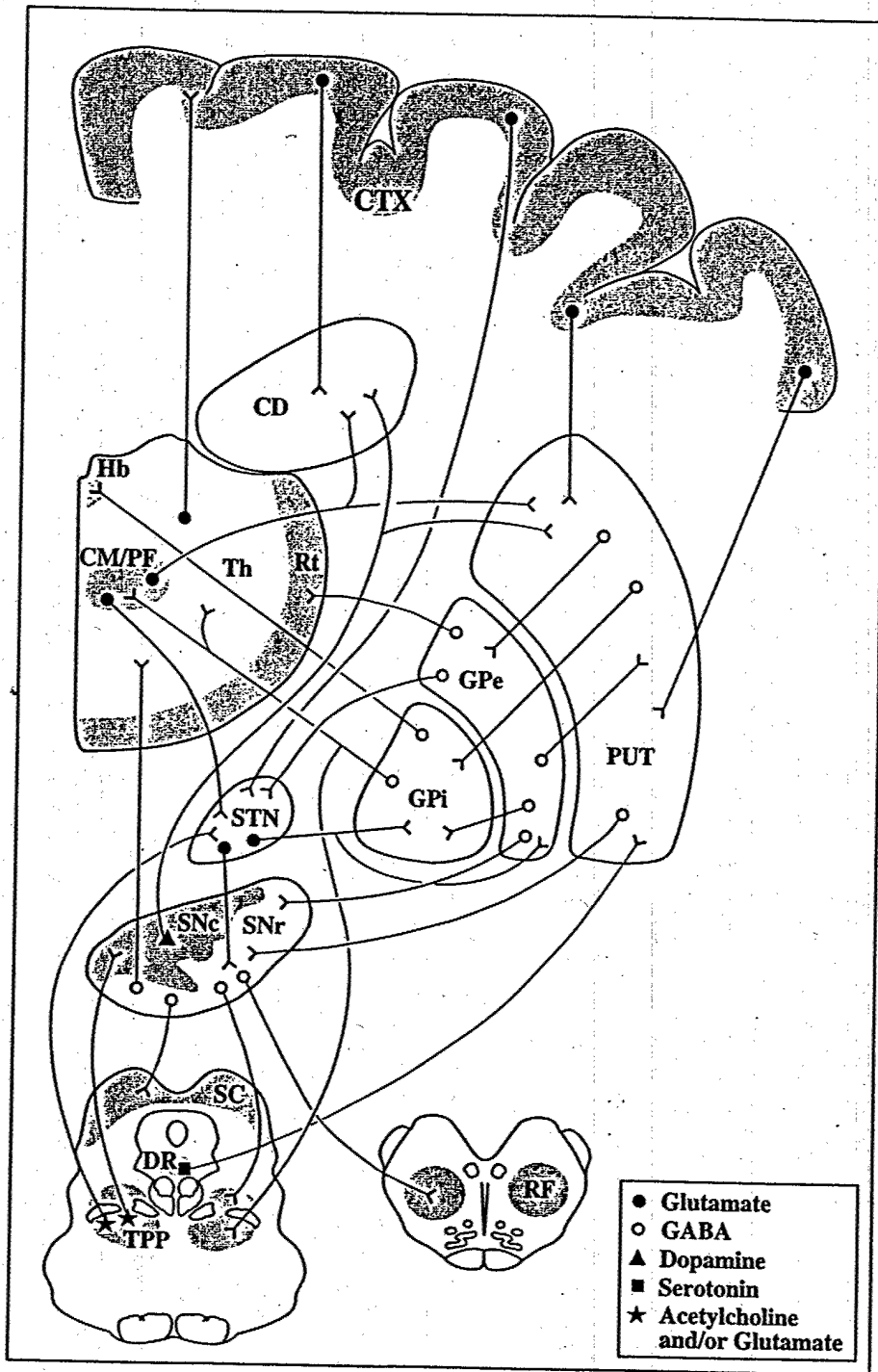

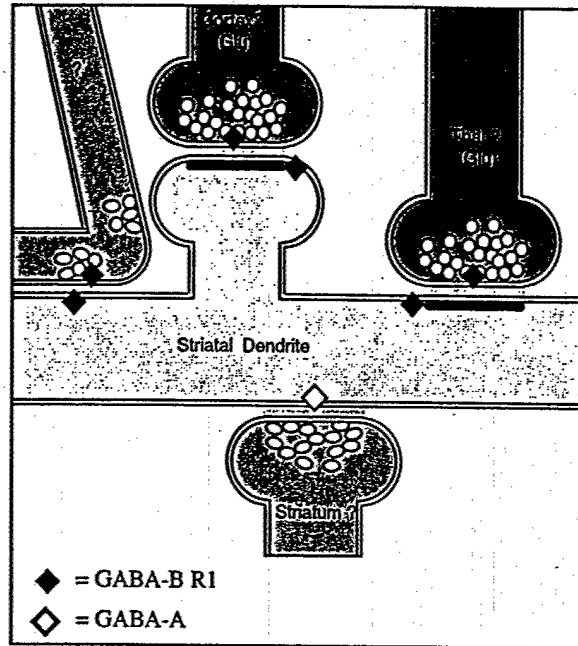
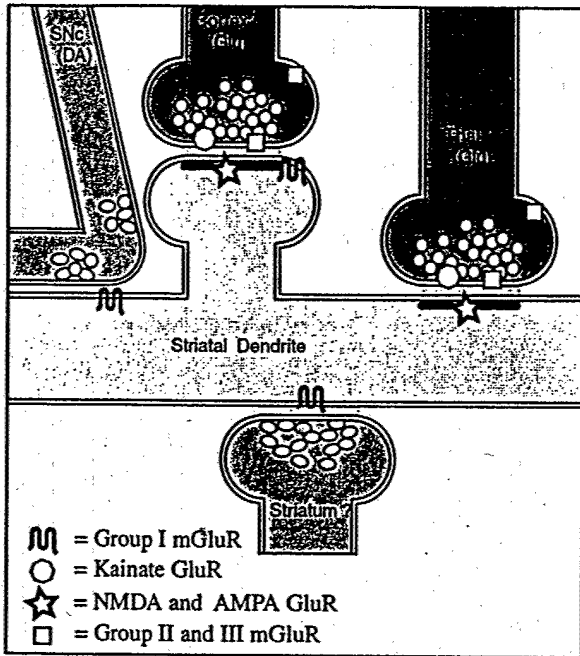

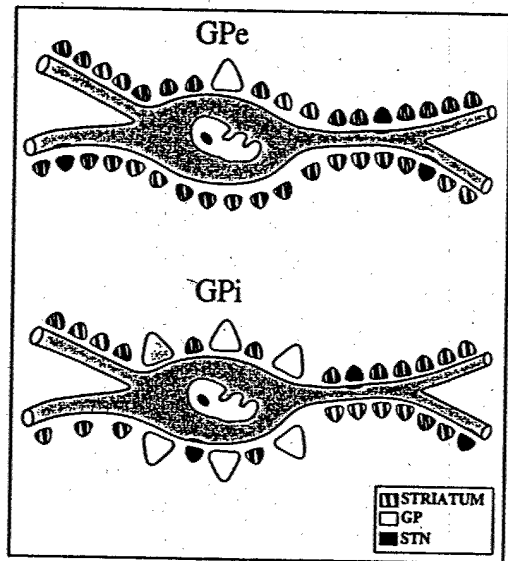

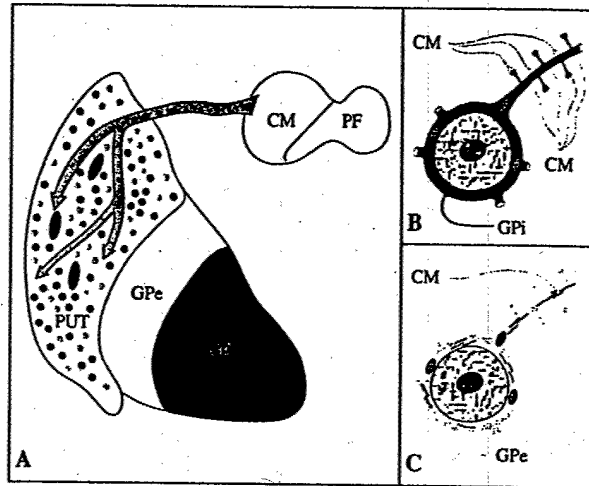

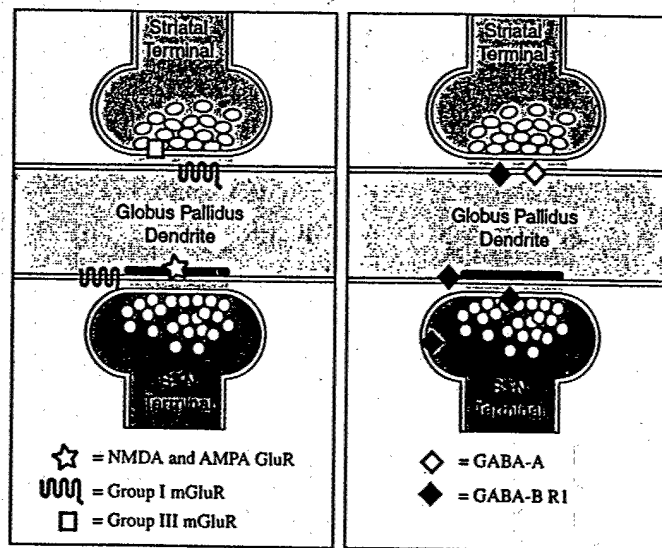

## Pallidal Output Channels

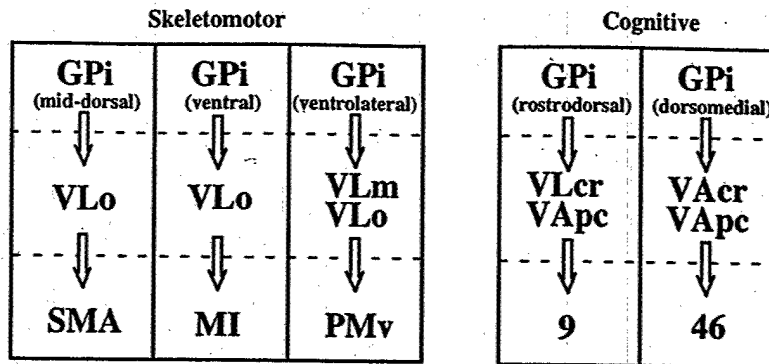

## Nigral Output Channels

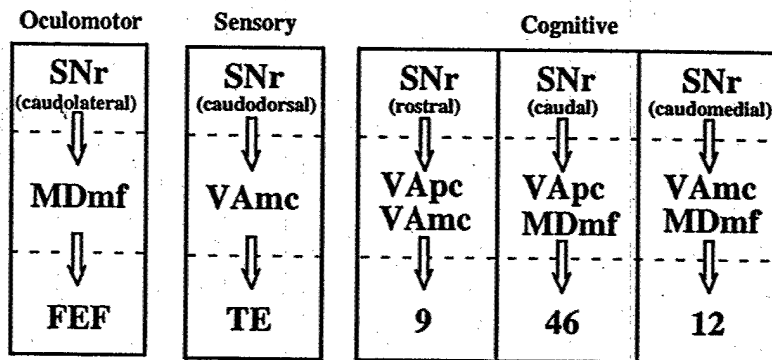

## Cerebellar Output Channels

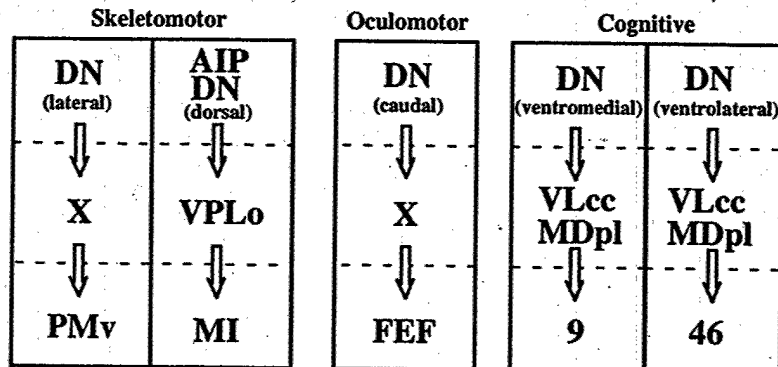

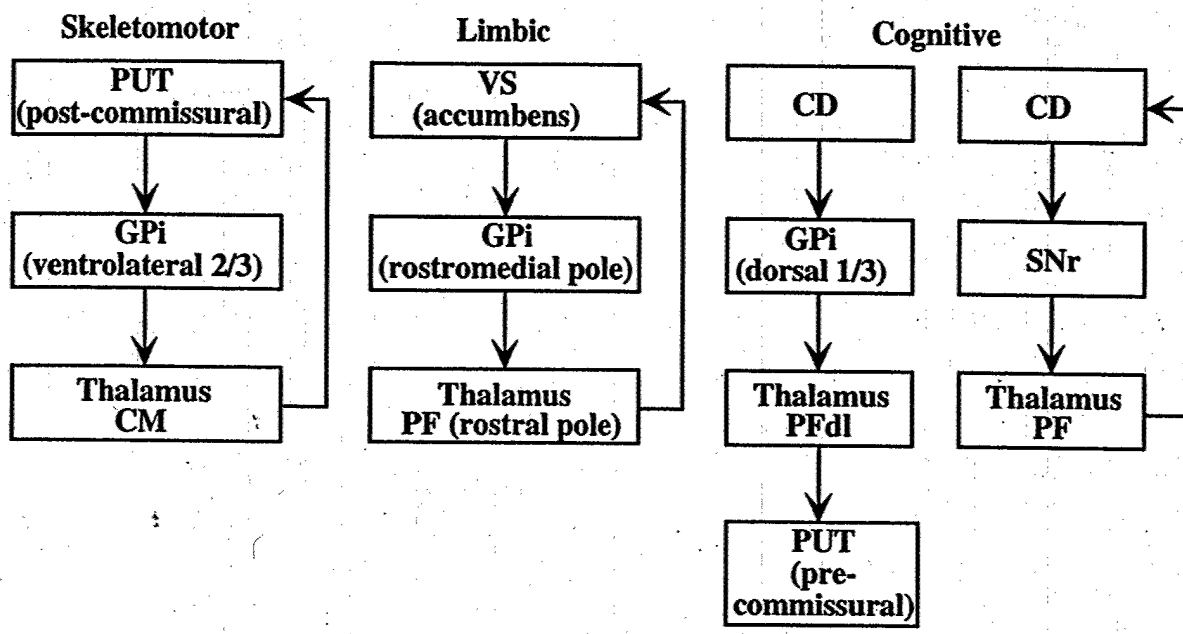

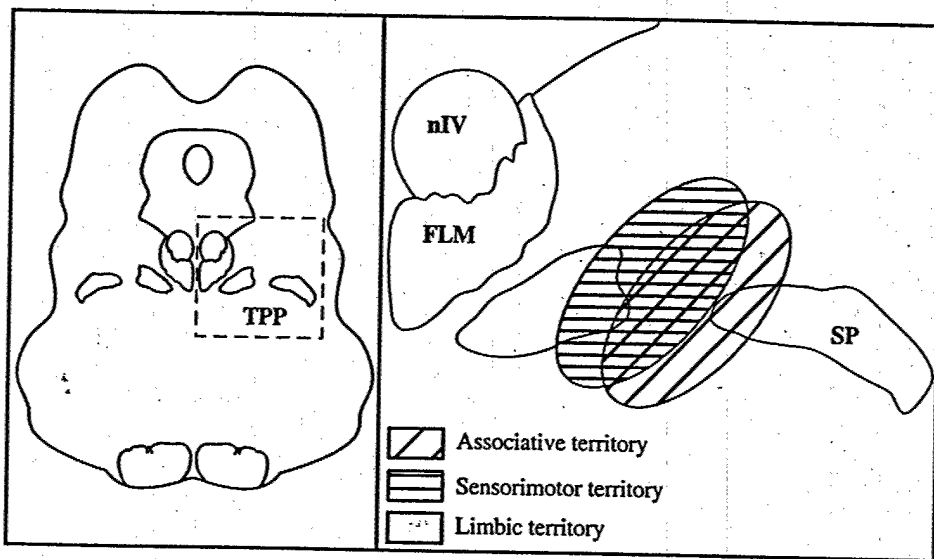

## PRE- AND POST-SYNAPTIC KAINATE RECEPTORS IN THE STRIATUM.

Yoland Smith, Jeremy Z. Kieval and Ali Charara  
Yerkes Primate Ctr and Dept Neurology, Emory Univ., Atlanta, GA 30322, USA.

Recent evidence indicates that GluR6 genotype variation might underlie striatal neuronal degeneration in some Huntington's (HD) patients. To better understand the potential functions of kainate receptors (KAR) in the basal ganglia, the goal of this study was to characterize the subcellular and subsynaptic localization of GluR6/7 and KA2 KAR subunits in the monkey striatum.

Both GluR6/7- and KA2 immunoreactivity (IR) is expressed presynaptically in a subpopulation of glutamatergic terminals and postsynaptically in dendrites throughout the primate striatum. The relative abundance of GluR6/7- and KA2-immunoreactive terminals is homogeneous throughout the striatum irrespective of the differential degree of striatal degeneration in HD. Pre- and postembedding immunogold data indicate that more than 80% of the pre or postsynaptic GluR6/7 and KA2 labeling is expressed intracellularly while the majority of gold particles bound to the plasma membrane are found extrasynaptically. A small proportion of synaptic and perisynaptic labeling at asymmetric synapses is also seen. In material stained with the postembedding immunogold method, both GluR6/7 and KA2 labeling in glutamatergic terminals often occurs in clusters of gold particles along the membrane of large vesicles located at various distances from the presynaptic grid. Anterograde labeling from the primary motor cortex or the thalamus indicate that both corticostriatal and thalamostriatal terminals express presynaptic GluR6/7 and KA2 IR.

In conclusion, these data demonstrate that striatal KAR display a pattern of subcellular distribution different from other ionotropic glutamate receptor subtypes, but consistent with their metabotropic-like functions recently shown in the hippocampus. Furthermore, their expression in glutamatergic terminals suggest that malfunction of these receptors, as might happen in some HD patients, may lead to excitotoxic striatal cell death.

*{Supported by NIH grant RR 00165 and a grant for the US Army}*

**Key Words:** Huntington's disease, excitotoxicity, primate, presynaptic receptor.

Program Number: 291.9

Day / Time: Monday, Nov. 12, 8:00 AM - 9:00 AM

**KAINATE RECEPTORS IN THE PRIMATE STRIATUM: RELATIONSHIP WITH DIRECT AND INDIRECT STRIATOFUGAL NEURONS.**

J.L.Weeks<sup>\*1</sup>; R.Kane-Jackson<sup>1</sup>; Y.Smith<sup>1,2</sup>

1. Yerkes Primate Ctr, Emory Univ, Atlanta, GA, USA; 2. Neurology, Emory Univ, Atlanta, GA, USA

Our previous studies have revealed the existence of pre-synaptic kainate receptors (KAR) in glutamatergic terminals in the primate striatum (STR). This raises the possibility that dysfunction of these receptors could be involved in the selective death of striatofugal neurons in Huntington's disease (HD). Recently, it was reported that a subset of HD patients have a mutation in the GluR6 gene, a component of the kainate receptor. The "direct" and "indirect" pathways of the basal ganglia show a differential pattern of degeneration in HD, suggesting the possibility that this could be mediated by a differential innervation of striatofugal neurons by KAR-containing glutamatergic terminals. To test this hypothesis we have undertaken an electron microscopic analysis of the synaptic relationships between KAR-containing terminals and the two populations of striatofugal neurons in monkeys. To do so we combined pre-embedding immunogold labeling for GluR6/7 with retrograde labeling of direct and indirect striatofugal neurons, which project to the internal (GPI) and external (GPe) segments of the globus pallidus respectively. Data obtained thus far have revealed: (1) Post-synaptic GluR6/7 immunoreactivity (IR) in dendrites and spines is largely intracellular, (2) Pre-synaptic GluR6/7 IR is confined intracellularly to terminals forming asymmetric synapses and (3) None of the GluR6/7 IR terminals examined formed synapses with retrogradely labeled "direct" striatofugal neurons. Experiments are in progress to determine the relationship between GluR6/7 IR terminals and striatofugal neurons that project to the GPe.

*Supported by: NIH and the United States Army*

Application Design and Programming© ScholarOne, 2001. All Rights Reserved. Patent Pending.

**Kane-Jackson, R. and Y. Smith (2002). PRE- AND POST-SYNAPTIC KAINATE RECEPTORS IN THE MONKEY GLOBUS PALLIDUS. Soc. for Neurosci. Abstr 359.16.**

The functions and localization of kainate receptors (KARs) in the basal ganglia are still poorly known. On the other hand, KARs were found to act as pre-synaptic heteroreceptor that modulate GABA release in the rat hippocampus. Pre-synaptic functions of KARs have also been established in other brain regions including the striatum, where they appear to modulate GABA and glutamate release. In order to better understand the potential functions of KARs throughout the basal ganglia circuitry, we undertook an electron microscopic immunocytochemical analysis of the GluR6/7 KARs subunit in the monkey globus pallidus. At the light microscopic level, GluR 6/7 immunoreactivity was homogeneously distributed in neuronal cell bodies, dendrites and fine neuropil elements in both the external (GPe) and internal (GPi) segments of the globus pallidus. At the electron microscopic level, postsynaptic labeling was found in large and small dendrites of both GPe and GPi neurons, but pre-synaptic labelling of small unmyelinated axons was also encountered in both pallidal segments. However, a population of putative GABAergic striatal boutons displayed GluR 6/7 immunoreactivity in GPi but not in GPe, suggesting that pre-synaptic KARs may be differentially distributed on "direct" and "indirect" striatofugal GABAergic projections in monkeys. Glial cell processes also showed immunoreactivity in both pallidal segments. In conclusion, KARs are located to subservise postsynaptic functions in both pallidal segments, but appear to be preferentially expressed pre-synaptically in striato-GPi terminals, suggesting that they may modulate GABA release differentially along the two major striatofugal pathways. These findings set the stage for further studies of KARs functions and pave the way for the potential development of novel therapeutic strategies for movement disorders.