

ARMY RESEARCH LABORATORY



**Ignition and Flame Propagation in Narrow Channels of
Solid Propellant**

by Lang-Mann Chang and Douglas E. Kooker

ARL-TR-3011

July 2003

Approved for public release; distribution is unlimited.

20030807 085

NOTICES

Disclaimers

The findings in this report are not to be construed as an official Department of the Army position unless so designated by other authorized documents.

Citation of manufacturer's or trade names does not constitute an official endorsement or approval of the use thereof.

Destroy this report when it is no longer needed. Do not return it to the originator.

Army Research Laboratory

Aberdeen Proving Ground, MD 21005-5066

ARL-TR-3011

July 2003

Ignition and Flame Propagation in Narrow Channels of Solid Propellant

**Lang-Mann Chang and Douglas E. Kooker
Weapons and Materials Research Directorate, ARL**

REPORT DOCUMENTATION PAGE			Form Approved OMB No. 0704-0188		
Public reporting burden for this collection of information is estimated to average 1 hour per response, including the time for reviewing instructions, searching existing data sources, gathering and maintaining the data needed, and completing and reviewing the collection information. Send comments regarding this burden estimate or any other aspect of this collection of information, including suggestions for reducing the burden, to Department of Defense, Washington Headquarters Services, Directorate for Information Operations and Reports (0704-0188), 1215 Jefferson Davis Highway, Suite 1204, Arlington, VA 22202-4302. Respondents should be aware that notwithstanding any other provision of law, no person shall be subject to any penalty for failing to comply with a collection of information if it does not display a currently valid OMB control number. PLEASE DO NOT RETURN YOUR FORM TO THE ABOVE ADDRESS.					
1. REPORT DATE (DD-MM-YYYY) July 2003		2. REPORT TYPE Final		3. DATES COVERED (From - To) June 1999–December 1999	
4. TITLE AND SUBTITLE Ignition and Flame Propagation in Narrow Channels of Solid Propellant				5a. CONTRACT NUMBER	
				5b. GRANT NUMBER	
				5c. PROGRAM ELEMENT NUMBER	
6. AUTHOR(S) Lang-Mann Chang and Douglas E. Kooker				5d. PROJECT NUMBER 622618H80	
				5e. TASK NUMBER	
				5f. WORK UNIT NUMBER	
7. PERFORMING ORGANIZATION NAME(S) AND ADDRESS(ES) U.S. Army Research Laboratory ATTN: AMSRL-WM-BD Aberdeen Proving Ground, MD 21005-5066				8. PERFORMING ORGANIZATION REPORT NUMBER ARL-TR-3011	
9. SPONSORING/MONITORING AGENCY NAME(S) AND ADDRESS(ES)				10. SPONSOR/MONITOR'S ACRONYM(S)	
				11. SPONSOR/MONITOR'S REPORT NUMBER(S)	
12. DISTRIBUTION/AVAILABILITY STATEMENT Approved for public release; distribution is unlimited.					
13. SUPPLEMENTARY NOTES					
14. ABSTRACT Future direct-fire gun systems will require solid propellant at high loading density, which can be achieved with propellant in slab-type geometry such as radial discs, concentric wraps, or scrolls. Adjacent propellant slabs will form porosity as narrow sheet-like channels (with entirely different permeability than bundled sticks or cylindrical grains). Successful functioning of the charge requires rapid ignition and unimpeded flame propagation throughout this system of channels. The present investigation is concerned with characterizing the fundamental ignition and transient combustion behavior of energetic materials when packed in such configurations. A special laboratory apparatus was designed to isolate two propellant channels and allow direct comparison of the influence of variable gap width, wall composition (inert or JA2 here), and channel end closure. Diagnostics include multiple pressure time histories along each channel length and high-speed cinematography of the propagation of flame. Results are presented for several channel configurations, showing influence of JA2 or plastic wall material, gap widths of 0–0.89 mm, and channel downstream ends either open or closed.					
15. SUBJECT TERMS solid propellant, narrow channel, ignition, flame propagation					
16. SECURITY CLASSIFICATION OF:			17. LIMITATION OF ABSTRACT UL	18. NUMBER OF PAGES 20	19a. NAME OF RESPONSIBLE PERSON Lang-Mann Chang
a. REPORT UNCLASSIFIED	b. ABSTRACT UNCLASSIFIED	c. THIS PAGE UNCLASSIFIED			19b. TELEPHONE NUMBER (Include area code) (410) 278-6107

Contents

List of Figures	iv
List of Tables	iv
1. Introduction	1
2. Background	2
3. Experiment Apparatus	5
3.1 Channel With Open or Closed End	6
3.2 Inert (Plastic) or Live Propellant Channel Walls	6
3.3 Ignition Sources.....	7
4. Results and Discussion	7
5. Conclusions	12
6. References	14

List of Figures

Figure 1. Narrow channels in a scroll or concentric wrap propellant.....	1
Figure 2. Experimental apparatus.....	6
Figure 3. Run 1: plastic/plastic and $W = 0.6$ mm for both channels; open end vs. closed end.	9
Figure 4. Run 2: plastic/JA2 and $W = 0.33$ mm for both channels; open end vs. closed end.	10
Figure 5. Run 3: plastic/JA2 for both channels (open end); $W = 0.33$ mm vs. $W = 0.89$ mm.	11
Figure 6. Run 4: $W = 0$ mm for both channels (open end); plastic/JA2 vs. JA2/JA2.	13

List of Tables

Table 1. Example runs of the narrow-channel simulator.....	8
--	---

1. Introduction

All current efforts to improve performance of large-caliber direct-fire gun systems (based on stored chemical energy) assume a propelling charge at significantly higher loading density. Packing additional solid propellant into the gun combustion chamber can be achieved with propellant in slab-type geometries such as radial discs, concentric wraps, and scrolls. Clearly though, adjacent propellant slabs will form porosity as narrow sheet-like channels (with entirely different permeability than bundled sticks or cylindrical grains). A high loading density propelling charge will necessarily incorporate a multitude of these narrow channels, as shown schematically in Figure 1, for a scroll configuration. Successful functioning of the charge design requires rapid ignition and unimpeded flame propagation throughout this system of channels. The present investigation is concerned with characterizing the fundamental ignition and transient combustion behavior of energetic materials when packed in such configurations. The objective is to design and construct a laboratory apparatus which isolates one or two channels to allow study of the ignition and flame propagation behavior as a function of channel gap width, pressure level, and composition of energetic material. Such experiments should be able to determine (1) a range of channel widths, as a function of pressure, which effectively prevents ignition, (2) the speed of flame propagation in channel widths above the threshold value, (3) the influence of full

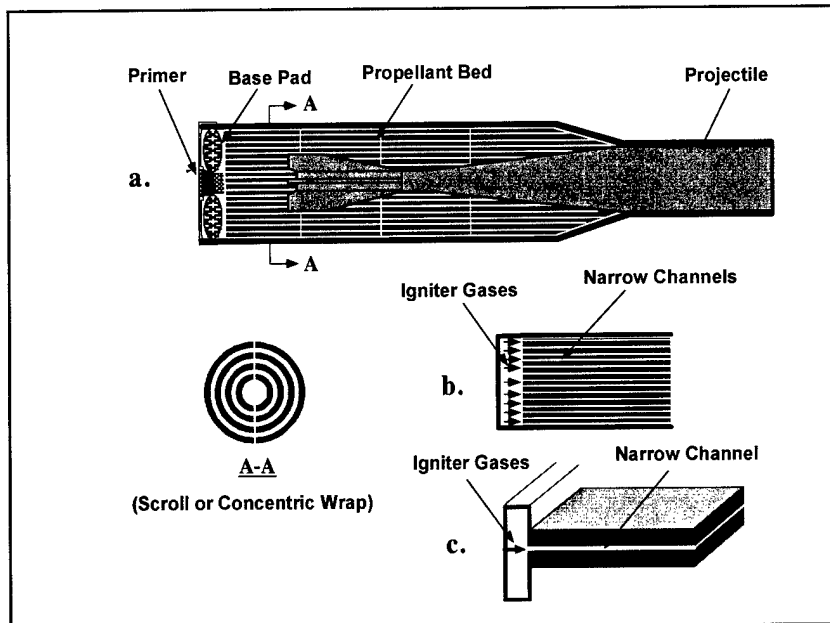

Figure 1. Narrow channels in a scroll or concentric wrap propellant.

or partial flow blockage in the channel, and (4) some indication of possible augmented burning rate in channels which support combustion. If, in addition, the design of the apparatus also allows use of a plasma ignition source, then behavior under simulated electrothermal chemical (ETC) conditions could be compared to that induced by conventional igniters. This database should be influential in future development of propelling charges based on solid propellant in slab geometries; it may also prove critical in guiding development of interior ballistic codes and validating predictions of ignition and flame propagation in these charges.

2. Background

During the 1950s and 1960s, there was a considerable effort in the former Soviet Union to investigate deflagration of porous energetic materials (1), with particular emphasis on establishing the conditions under which a planar or layer-by-layer combustion process might give way to a convective process where flame "penetrates" into the solid (often referred to as "unstable" combustion in the Russian literature). This shift in mechanism can substantially accelerate the wave speed, which is of great interest to understanding the transition to detonation. A subset of this work, however, also looked at flame propagation into single cracks and/or isolated "pores" within an otherwise homogeneous energetic material. For example, Belyaev et al. (1) discussed the critical conditions for combustion to penetrate into an isolated, closed-end, rectangular slit-like pore within an energetic material. Each sample consisted of a confined rectangular parallelepiped (large length-to-diameter ratio, but no dimensions provided) formed by a single slab of energetic material positioned parallel to one wall of the Plexiglas* confinement but offset by an adjustable air gap. The end-ignited sample was placed in a constant-pressure strand burner (apparently capable of 100 atm) and monitored as combustion propagated toward the closed end (blind pore). For a given gap width, each of four energetic materials (cyclotrimethylene trinitramine [RDX], nitroglycerine [NG], and two composite rocket propellants) was shown to exhibit a threshold value of pressure, above which the flame would penetrate or "flash" into the pore. Below this pressure level, the flame would not penetrate into the pore, and the strand merely burned at the normal regression rate. These results for threshold pressure vs. pore diameter showed an inverse relationship—somewhat hyperbolic. Furthermore, a material with faster intrinsic burning rate exhibited a lower value of critical pressure.

It was also noted that the flash down threshold conditions remained the same for blind flat pores formed by two slabs of energetic material. However, as noted in Bradley and Boggs (2), convective combustion subsequent to flash-down may be quite different in pores formed by two slabs of energetic material. Bradley and Boggs provide an extensive review of Russian and U.S. literature concerning convective combustion in defects and discuss additional configurations

* Plexiglas is a registered trademark of Elf Atochem N. America, Inc.

such as pores with an open end, pores uncovered during combustion, and the different response between round holes and flat cracks. A clear observation is that flame penetrates much easier into a pore with an open end, as might be expected from the improved convective flow and heat transfer into an open channel.

Similar physics may govern flame propagation through a granular propellant bed. In the mid 1980s, Miller (3, 4) at the U.S. Army Research Laboratory (ARL) studied the transfer of flame from grain to grain, as well as flame propagation into the perforations of a single grain. Using 19-perf cylindrical grains of low-vulnerability ammunition (LOVA) propellant (XM39), Miller axially aligned six grains in a vertical orientation (~1.58-mm gap between end faces), where some attempt was also made to align the perforations. This array was end ignited at the top, and the combustion event was observed at nearly constant pressure in a low-pressure strand burner, with a gentle upward purge flow of nitrogen. For lower pressures and smaller perforation diameters, the downward-propagating combustion wave proceeded at the normal linear burning rate of the propellant. However, above a threshold condition (dependent upon pressure and perforation diameter), the combustion wave involved "flash down" into the grain perforations and then from grain to grain, characterized by an effective flame-spreading rate some 20 times the normal linear burning rate. It was noted that flame would not propagate down the outside surface of the grain array faster than the normal burning rate.

To assess the possible influence of grain-to-grain proximity, Miller (3, 4) constructed another experiment where two solid strands (cylinders with a diameter = 3.8 mm and a length = ~50 mm) were held parallel in a vertical orientation within the same constant pressure chamber and end ignited at the top. For most pressure levels and gap widths, the strands burned independently at the normal burning rate. However, the pressure/gap-width map also contained a threshold region where flamespreading between the strands would propagate at some 10 to 20 times the normal burning rate (i.e., a "super rate" appeared, even without the influence of confinement). Miller noted that the flame bridging the gap between the strands associated with the super rate was noticeably brighter than the normal flame on an isolated strand (which is barely visible for this LOVA propellant). In later work, Miller repeated these experiments using grains of JA2 and M30 solid propellant, both of which had a different flame zone structure than the LOVA propellant, as well as a faster burning rate. Both JA2 and M30 exhibited similar flame-spreading behavior, characterized by a "super rate" when exceeding certain threshold conditions. Thus, the extended two-stage flame zone structure of LOVA propellants at lower pressure could not be the sole cause of this effect. Miller found that the threshold conditions controlling flash down into perforations, for all three propellants, would nearly collapse onto a universal curve, relating critical perforation diameter to the intrinsic burning rate. Miller's observations, indeed intriguing, remain unexplained. The ability to exploit an ignition wave propagating at the super rate could well be important to the design of a high-loading density propelling charge.

Andoh and Kubota (5) and Andoh (6, 7) conducted a series of tests to investigate how solid propellant flame may penetrate a defect suddenly uncovered during the combustion event. The propellants were all double base (typically 50% nitrocellulose [NC] and 35%–40% NG); a few samples incorporated a small amount of lead catalyst, which increased the burning rate, and others contained nickel, which induced a visible flame zone just above the surface but otherwise did not alter the burning rate. The propellant samples were rectangular parallelepipeds, with a 7- × 7-mm cross section and a 30-mm length (5), and up to 20 × 20 mm and a 40-mm length (6). The end-ignited samples would burn some 15 to 25 mm before the defect or pore was uncovered, where all pores were cylindrical holes, 1–8 mm in diameter and 15–30 mm in length. The sample was confined in a constant-pressure strand burner (with a nitrogen purge flow), with an upper pressure limit apparently near 10 atm. Virtually all the results pertained to a cylindrical pore with an open end; no flame penetration was observed in a closed-end pore. The closed-end pore result was no doubt correct but appeared to contradict the Russian results; the upper pressure limit of the strand burner and the slower intrinsic burning rate of the double base propellant may be part of the explanation. Andoh did find that a faster intrinsic burning rate and increased flame temperature (incorporated into his modified time variable) both enhanced flame penetration into open pores, as did the visible flame structure induced by the nickel additive. Andoh's extensive fine-wire thermocouple data within the open pore support the conclusion that the controlling influence is convective heat transfer through the pore preceding the establishment of flame. But most important, the data show that at a given pressure level there is a value of pore diameter at which flame penetration speed is a maximum (i.e., a U-shaped curve). Although not computed by Andoh, the data for a 2-mm-diameter open-end pore at atmospheric pressure support a propagation speed some 15 times the intrinsic burning rate of the propellant.

In the late 1970s and early 1980s, Kuo et al. (8), Kumar and Kuo (9, 10) and Kumar et al. (11) designed, constructed, and modified a laboratory device which simulated flame propagation into an isolated closed-end crack in rocket motor propellant (primarily ammonium-perchlorate [AP]/polybutadiene-acrylic acid [PBAA] copolymer and AP/hydroxyl-terminated poly-butadiene [HTPB]). The motivation was apparently the problem of suddenly uncovering a crack in the rocket motor grain with the engine at full thrust. The laboratory device was basically a scaled rocket chamber with choked nozzle, but normal to the chamber was a special holder for a slab of propellant containing the slot/crack. The fixture holding the propellant with slot was instrumented by pressure transducers and contained a clear plastic window for monitoring propagation of visible light. The slot/crack was created in the following two ways:

- (1) A slot was machined (or cast) into the propellant, with the narrow edge of the slot facing the plastic window.
- (2) A gap was formed between the recessed machined face of the propellant slab and the parallel plastic window, thereby permitting a frontal "full-width" view of the slot.

The scaled combustion chamber could achieve pressures >200 atm within 2 ms; thus, the entrance to the crack saw pressurization rates up to 5×10^5 atm/s. The early work of Kuo et al. (8) concentrated primarily on model development, but did include an experimental data set for a "smokeless propellant." Early experiments apparently observed that, when the chamber pressurization rate was large, the crack tip region might ignite first. This could be followed by flamespreading in both directions, rearward from the crack tip region and forward from the crack entrance. Kumar and Kuo (9) reported an attempt to isolate just the influence of the crack tip region (lateral walls of the crack are inert). Kumar et al. (10) studied a full-length propellant crack; results for a crack length of 195 mm and a gap width of 0.9 mm showed propagation of an ignition front into the crack at speeds of 400–800 m/s during the first 1 ms. However, luminosity from the crack quickly became quite nonuniform as a function of length, representing typical combustion response within the crack. Furthermore, decreasing crack gap width to <0.5 mm appeared to usher in a host of nonlinear behavior, including a "galloping" structure apparently resulting from multiple crack closures interspersed with regions of luminous combustion (11). The combustion process within the solid propellant crack was indeed a complex phenomenon.

3. Experiment Apparatus

The design of the laboratory simulator used in the present investigation was motivated by a direct-fire gun combustion chamber containing slab-type solid propellant at a high-loading density, as illustrated in Figure 1 for scroll propellant. The ignition process commences with the functioning of the primer, which must cause ignition of the base pad and assure ignition and flamespreading throughout the propellant charge. Following initiation of the base pad, igniter gases will quickly fill the rear ullage and attempt to enter the multitude of "channels" between adjacent propellant sheets, as illustrated in Figure 1b. For the purpose of the laboratory apparatus, it is sufficient to isolate one or two propellant channels (see Figure 1c) and study their response to the hot-gas environment that simulates the functioning of the full-scale propelling charge.

The design of the narrow-channel simulator is shown in Figure 2. This apparatus, constructed from stainless steel, can accommodate two flow channels in parallel, both connected to a common cavity at each end. The arrangement allows a comparison testing of two channels with different properties (e.g., different gap widths) under the same hot-gas entrance condition. The rear chamber simulates the rear ullage behind a charge system (see Figures 1b and 1c) which fills with igniter gases as they begin to flow toward the edges of the slab propellant. In the simulator, the rear chamber fills with gases generated by combustion of igniter material. The igniter chamber assembly (see Figure 2) is divided into the subchamber on the right side, which holds the igniter material contained in a plastic bag, and the subchamber on the left side, which can be

disabled) and is designed to trap large particles from the igniter flow and prevent them from blocking the entrance to the narrow channels. The design of the simulator incorporates several additional important features (described in sections 3.1–3.3).

3.1 Channel With Open or Closed End

The downstream end of the channel can be fully open, partially open, or closed, simulating all possible flow restrictions in a propellant bed. It is also possible for hot gases to enter the narrow channels from both ends, by adjusting the flow control gate (see Figure 2) to direct a portion of the igniter gases through a hole in the steel block above the two channels to the forward chamber.

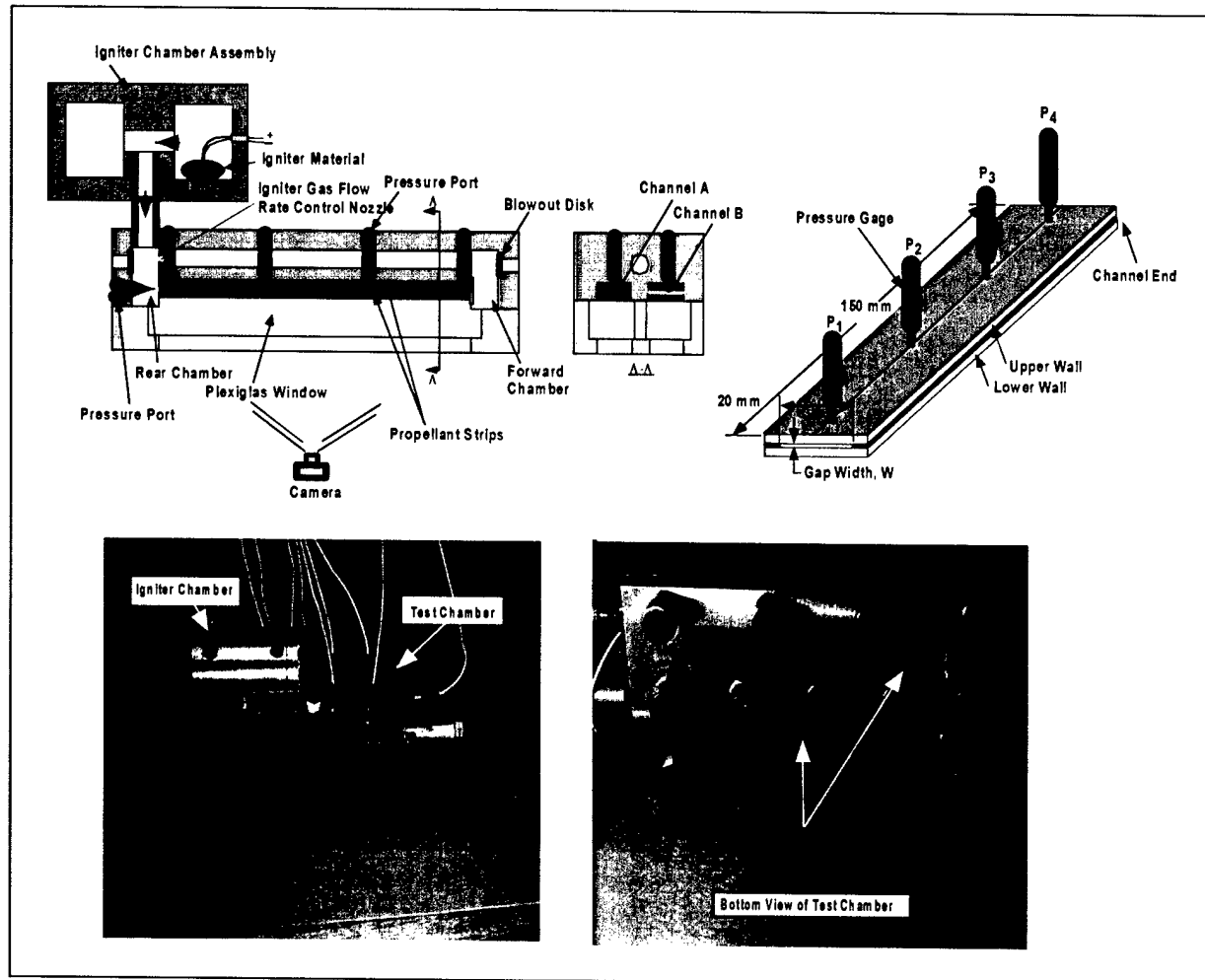

Figure 2. Experimental apparatus.

3.2 Inert (Plastic) or Live Propellant Channel Walls

The upper wall of the channel is typically live propellant, but the lower wall can be a propellant slab or an acrylic plate, supported by a heavy Plexiglas window which permits photography of flamespreading in the channel (see Figure 2). For example, the inert wall could simulate an

adjacent combustible cartridge case which might ignite on a much slower time scale. The dual channel design, of course, will allow comparison of flame propagation and transient combustion in a channel formed by two live propellant slabs, with a channel containing one inert slab.

If, as anticipated, propellant formulation and changes in gap width have a strong influence on ignition and flame propagation behavior, comparisons of several single channel experiments could easily be faced with an accuracy issue. However, the dual chamber design subjects both channels to the same igniter environment and hence allows direct comparison of different formulations of live propellant and different channel gap widths.

3.3 Ignition Sources

The igniter chamber assembly could be altered to accept a plasma ignition source, which then would allow comparison of the ignition and flame propagation behavior of ETC with conventional ignition sources. Considerable data now suggest that plasma can be an effective means for igniting a high loading-density charge; other investigators have claimed enhanced ballistic performance and suggested augmented burning rates and possibly elimination of temperature sensitivity of the burning rate. But, in fact, there is little direct evidence of how plasma interacts with solid propellant, especially in a high-loading-density slab configuration.

All propellant slabs held by the simulator have the same cross-sectional area, 150-mm length \times 20-mm width (or depth). The distance between parallel slabs, denoted by the gap width or channel width, is designed to vary from 0 to 2 mm; thus, the ratio of slab width to gap width will exceed nine and should ensure that edge effects are minimal and the interior flow field is essentially two-dimensional—similar to that within the actual propellant bed. Four pressure transducers are equally spaced along each channel length (see Figure 2) to monitor the local pressure time history within the channel. In addition, a pressure transducer is installed in the end wall of both the front chamber and the rear chamber to monitor conditions at the entrance and exit of the channels. Provisions have been made to eventually mount thermocouples in both these chambers to monitor gas temperature time history. In addition, because of the possibility of vigorous combustion proceeding simultaneously within both channels, a blowout disk is installed in the outer wall of both chambers, allowing a quick release of pressure above a prescribed level. Cinematography of the flame propagation and transient combustion is recorded by a Photec high-speed 16-mm camera, positioned to face the Plexiglas windows under the lower channel wall (see Figure 2).

4. Results and Discussion

The capabilities of the narrow-channel simulator are illustrated by four example runs (Table 1). In all cases, the live propellant was JA2, cut from sheets with a thickness of \sim 2.5 mm.

Table 1. Example runs of the narrow-channel simulator.

Run No.	Channel	Channel Walls (Upper Wall/Lower Wall)	Channel Gap (Width, W, mm)	Channel End	Remarks
1	A	Plastic slab/plastic slab	0.6	Open	Open end vs. closed end
	B	Plastic slab/plastic slab	0.6	Closed	
2	A	Plastic slab/JA2 slab	0.33	Open	Open end vs. closed end
	B	Plastic slab/JA2 slab	0.33	Closed	
3	A	Plastic slab/JA2 slab	0.33	Open	Influence of channel gap width
	B	Plastic slab/JA2 slab	0.89	Open	
4	A	Plastic slab/JA2 slab	0	Open	Live propellant wall vs. inert wall
	B	JA2 slab/JA2 slab	0	Open	

In Run 1, both channels have inert (plastic) walls, and $W = 0.6$ mm for comparison of open and closed downstream ends—illustrating the environment created by the igniter. In Run 2, both channels have one wall of JA2 and the other wall of plastic (inert), and $W = 0.33$ mm—comparison of open and closed downstream ends. In Run 3, both channels have one wall of JA2 and the other wall of plastic, and both downstream ends are open—comparison of two channel gap widths; $W = 0.33$ mm and $W = 0.89$ mm. In Run 4, one channel has both walls of JA2, and the second channel has one wall of JA2 and the other wall of plastic. The downstream end is open, and $W = 0$ mm (touching) for both channels.

Figure 3 displays the results from Run 1, which illustrates the environment created by combustion of 2 g of Class 5 black powder in the igniter chamber. Note that the time indicated is measured from the instant that the firing voltage was applied to the igniter. Both channels had inert walls, separated by a gap width of 0.33 mm; the downstream end of one channel was open, and the other was closed. The pressure recorded in the rear chamber, which is the condition imposed at the channel entrance, rises to ~ 4 MPa in ~ 11 ms (i.e., from 38–49 ms in the figure). The maximum pressurization rate is 5×10^3 atm/s, which is two orders of magnitude less than that generated in Kuo's apparatus (8-11). The present experiment is representative of the ignition environment of a direct-fire propelling charge. As expected, the open-end channel supports a time-varying but substantial axial pressure gradient, while the closed-end channel does not. This difference is not evident in photographic records which show visible flame penetrating less than a third of the channel length—for both channels. Heat loss from the igniter gases to the channel walls is probably the dominant effect responsible for the vanishing visible record.

Results from Run 2 are displayed in Figure 4, which illustrates the influence of the downstream end when each channel contains one wall of live JA2 propellant. The transducer time histories of both channels show pressures rising to over 8 MPa (indicating augmentation from combustion of the JA2 propellant) and evidence that the blowout disk ruptured in the forward chamber resulting in venting both channels. The pressure levels and pressurization rates are quite comparable for both channels, with the exception of P4 and an early-time pressure gradient

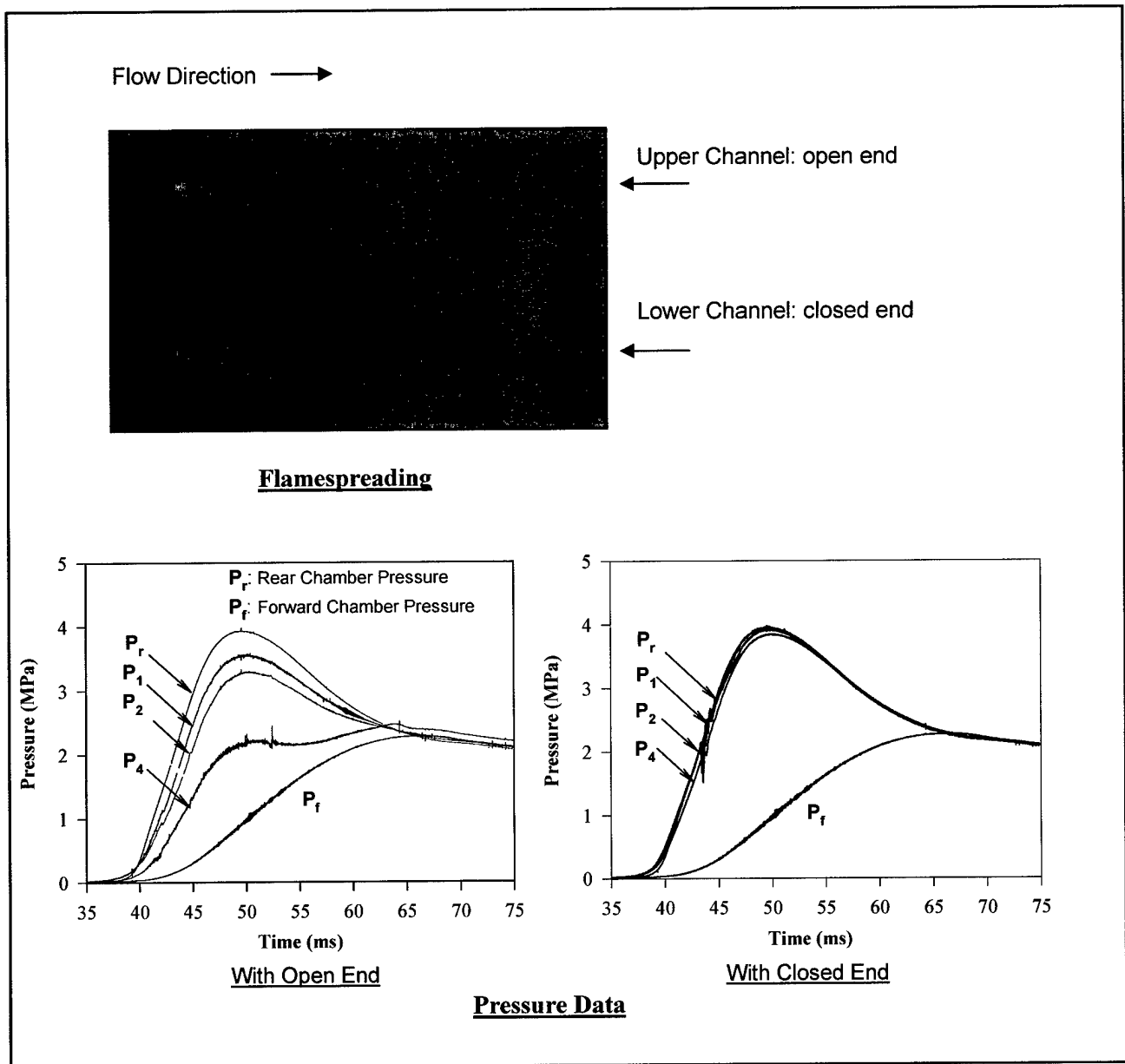

Figure 3. Run 1: plastic/plastic and $W = 0.6$ mm for both channels; open end vs. closed end.

in the closed-end channel. There is also a distinct pressure excursion seen by all gauges in the open channel at ~ 60 ms. The high-speed film shows a bright flame (see the second frame in the left column) appearing sooner in the open channel, and evidence of a time variation (or “pulsation”) in flame intensity in both channels, although peak intensity appears nearly the same. Note also that the midsection of each channel supports the brightest or more intense flame region. This could be due to gas-phase combustion of pyrolysis products evolved from the walls near the channel entrance or merely combustion of solid at the slightly elevated values of pressure.

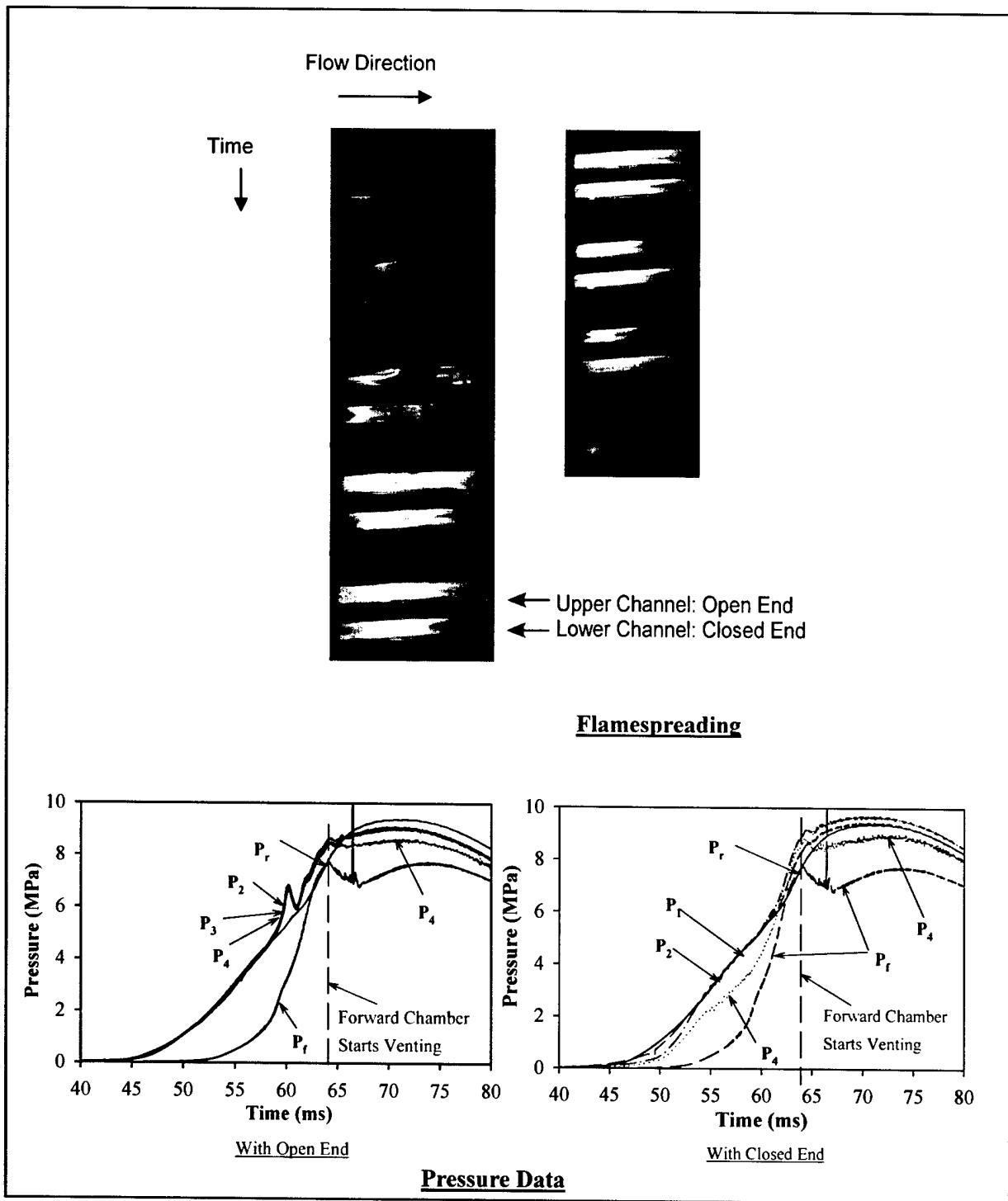

Figure 4. Run 2: plastic/JA2 and $W = 0.33$ mm for both channels; open end vs. closed end.

Figure 5 displays the results from Run 3, which contrasts the response of open-end channels with different gap widths, where each channel is configured with one live JA2 wall and one inert wall. In the photographic records, the channel at the top has a gap width of 0.33 mm, and the channel in the lower picture has a gap of 0.89 mm. The photographic data clearly show that the

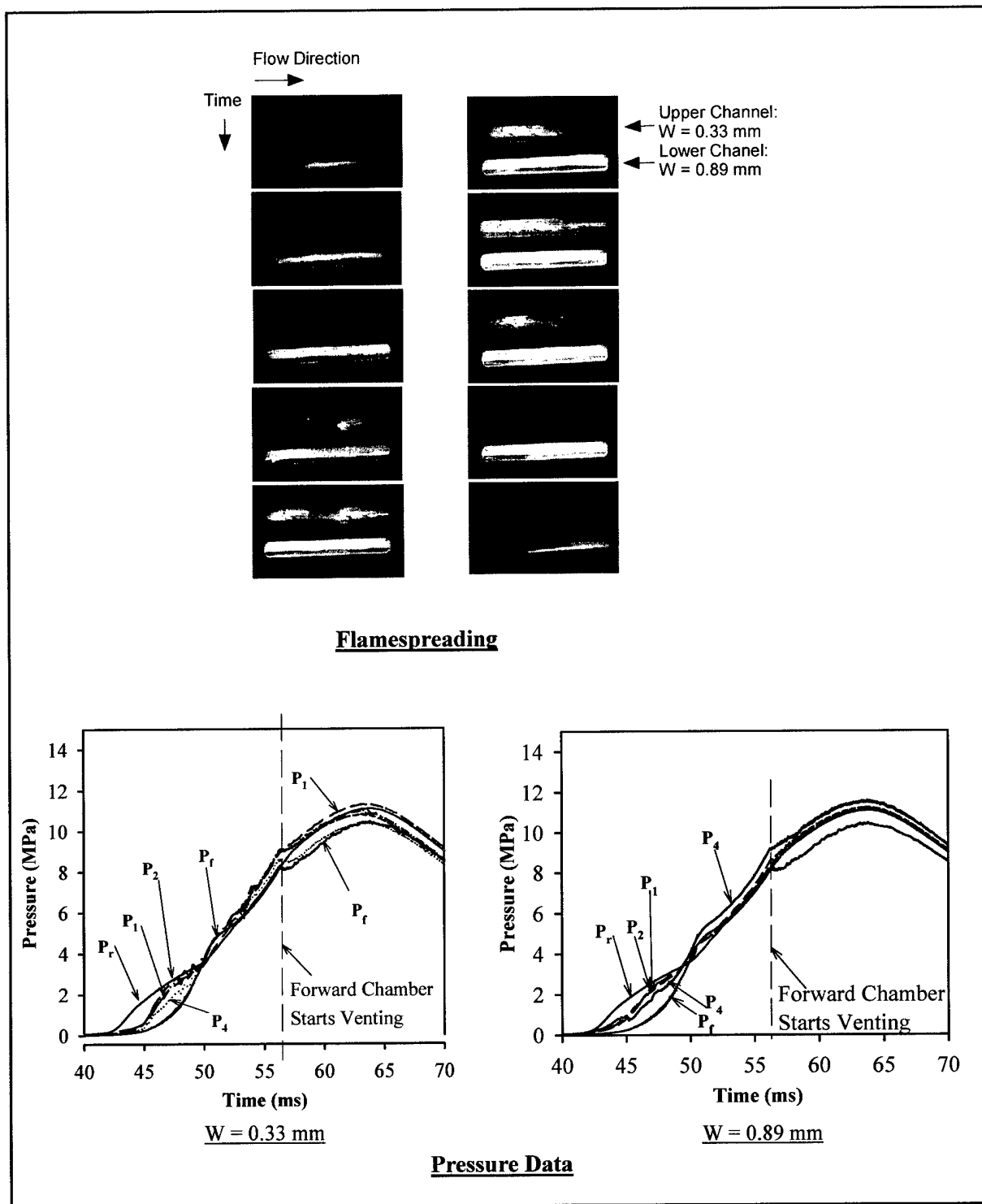

Figure 5. Run 3: plastic/JA2 for both channels (open end); $W = 0.33$ mm vs. $W = 0.89$ mm.

wide-gap channel exhibits luminosity well before its thinner neighbor. A careful comparison of the luminosity in sequential frames for the wide channel reveals a “pulsation” in time, involving most of the channel length. The narrow channel appears to support a similar but less-intense pulsation. The pressure time histories are similar in both channels, despite the differences in

luminosity. Another distinct feature is the response after the blowout disk ruptures in the rear chamber (~56 ms in Figure 5). Even though some type of combustion process is well underway within the channels at pressure levels of 8–10 MPa, the process is quenched by venting the rear chamber. It might have been anticipated that combustion of JA2 at 8 MPa within a narrow channel would be self-sustaining and simply continue to completion; it did not. Possibly, heat loss to the channel wall is important here. Postfire examination shows roughness of the JA2 surface, evidencing occurrence of combustion.

Figure 6 displays the results from Run 4, where both channels had a zero gap width (sides touching) and the downstream ends were open. The difference is that one channel had both walls of JA2 (lower channel indicated in Figure 6) and the other had one wall of JA2 and one wall of plastic (upper channel indicated in Figure 6). The two pressure time histories in the figure show that both channels experienced similar pressure levels, which now exceed 12 MPa (P_1 data lost for JA2/JA2; P_3 data lost for plastic/JA2). However, the photographic records show that visible flame first appears in the JA2/plastic channel and continues with the higher intensity. Here again is evidence of a “time pulsation” of intensity involving most of the channel length. The visible flame in the JA2/JA2 channel is weak due to the fact that the JA2 wall facing the optical window is less translucent in comparison with the plastic wall for the plastic/JA2 channel. It is important to note that the pressure time histories in the JA2/JA2 channel show distinct evidence of pressure excursions or spikes. It seems that this pressure spike behavior correlates with the pulsation of visible light within the channel. It also should be noted that, similar to Run 3, combustion quenched in both channels after the rupture of the blowout disk.

5. Conclusions

A laboratory apparatus was designed and constructed to study ignition and flame propagation in two channels with gap width from 0 to 2 mm. Certain results were anticipated, such as the mild pressure gradient and higher flow rate established in an open-end channel. Evidence of flame appeared earlier in the open-end channel and for the larger gap-width (both promoted higher convective flow rate of igniter gases). At least at the conditions studied here, however, flame did not propagate as a simple wave in the channel. Luminosity could appear suddenly within the channel, and the most intense luminosity normally occurred in the midsection of the channel. The luminosity was reduced for smaller gap widths. Certainly not anticipated was the fact that combustion within the narrow channel could generate a time pulsation of luminosity involving most of the length. The time histories from the transducers within the channel also reported distinct spikes, possibly with larger amplitude when the channel gap width was small. And finally, combustion quenched in all channels after rupture of the blowout disk, despite evidence of flame within the channel and pressure levels of 8–12 MPa.

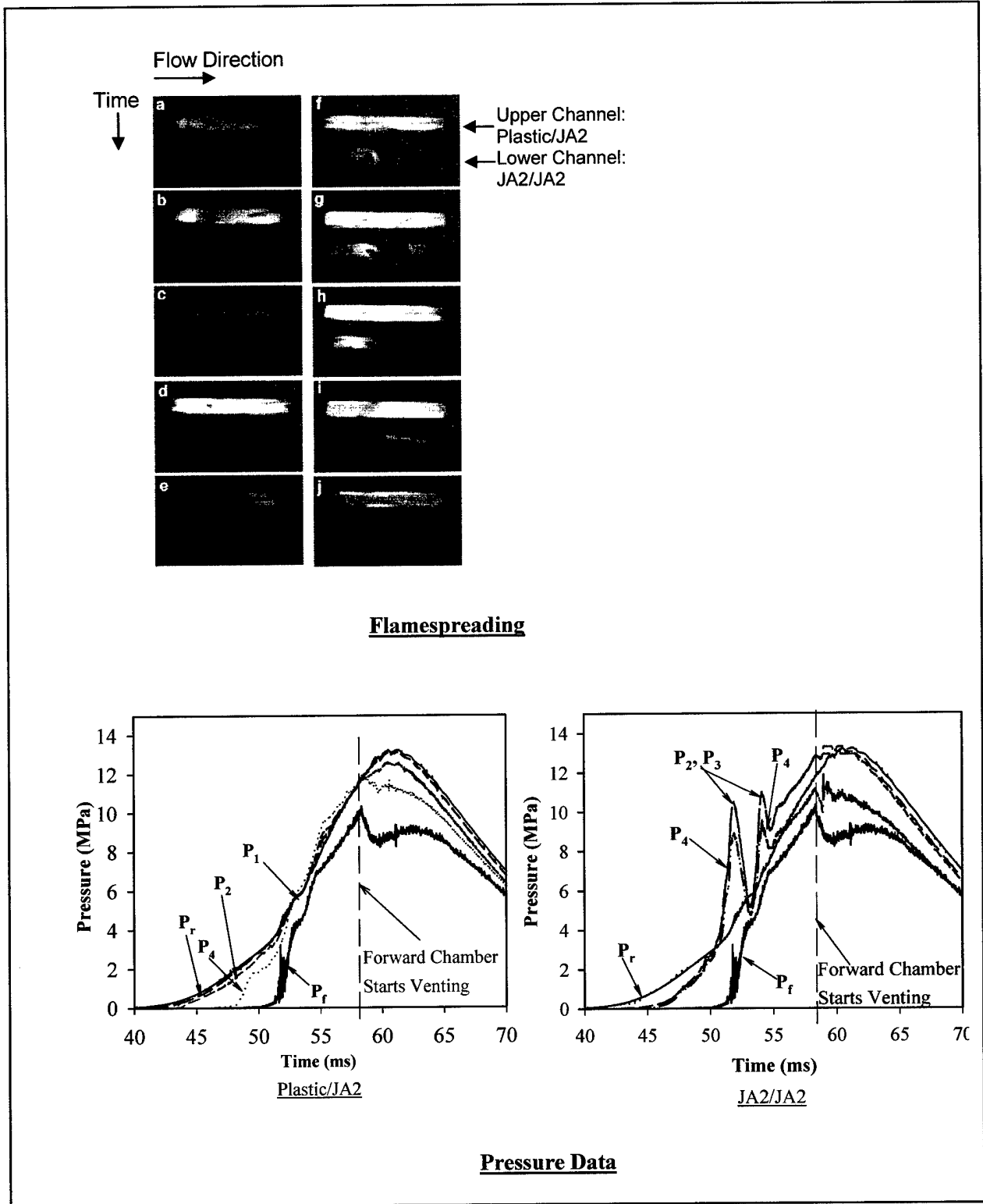

Figure 6. Run 4: $W = 0$ mm for both channels (open end); plastic/JA2 vs. JA2/JA2.

6. References

1. Belyaev, F.; Bobolev, V. K.; Korotkov, A. I.; Sulimov A. A.; Chuiko, S. V. *Transition From Deflagration to Detonation in Condensed Phases*, Volume 1, Chapter IV; Nauka, Moskva, 1973; translated from Russian, 1975, pp 78–80.
2. Bradley, H. H.; Boggs, T. L. *Convective Burning in Propellant Defects: A Literature Review*; NWC TP 6007; Naval Weapons Center: China Lake, CA, February 1978.
3. Miller, M. S. Flamespreading Measurements and Mechanisms in Perforated LOVA Gun Propellants, *Proceedings of the 23rd JANNAF Combustion Subcommittee Meeting*, CPIA Publication 457, October 1986; Vol. II, pp 329–335.
4. Miller, M. U.S. Army Research Laboratory, Aberdeen Proving Ground, MD. Private communication, September 1999 (additional data obtained in 1988–1989).
5. Andoh, E.; Kubota, N. Flame Penetration Into Solid Propellant Holes. *Propellants and Explosives* **1981**, *6*, 166–169.
6. Andoh, E. Flame Spreading Into a Hole With Rear End Open in a Double-Base Propellant: The Effect of Hole Diameter. *Combustion and Flame* **1993**, *92*, 334–345.
7. Andoh, E. Effects of Pressure, Initial Temperature, and Propellant Ingredients on Flame-Spreading Into a Hole. *Combustion and Flame* **1997**, *108*, 397–407.
8. Kuo, K. K.; Chen A. T.; Davis, T. R. Convective Burning in Solid-Propellant Cracks. *AIAA Journal* **1978**, *16* (6), 600–607.
9. Kumar, M.; Kuo, K. K. Ignition of Solid Propellant Crack Tip Under Rapid Pressurization. *AIAA Journal* **1980**, *18* (7), 825–833.
10. Kumar, M.; Kuo, K. K. Effect of Deformation on Flame Spreading and Combustion in Propellant Cracks. *AIAA Journal* **1981**, *19* (12).
11. Kumar, M.; Kovacic, S. M.; Kuo, K. K. Flame Propagation and Combustion Processes in Solid Propellant Cracks. *AIAA Journal* **1981**, *19* (5), 610–618.